

SERVICETEKNOTES

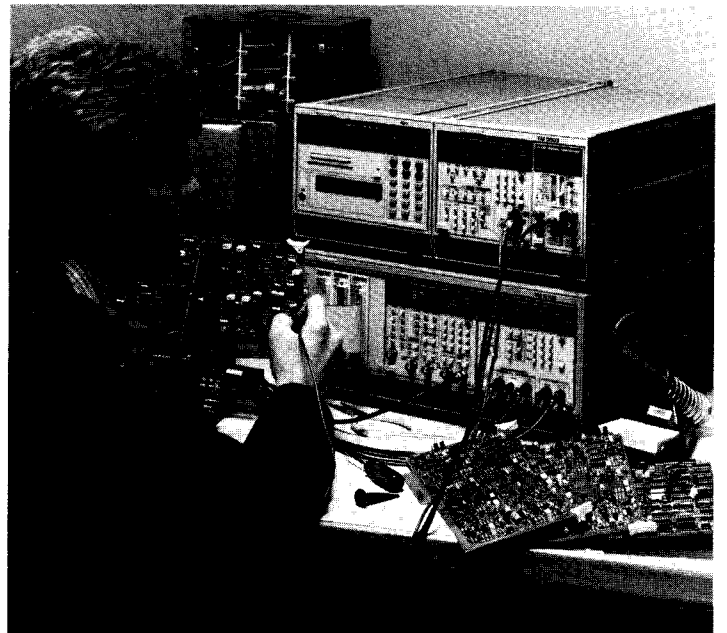
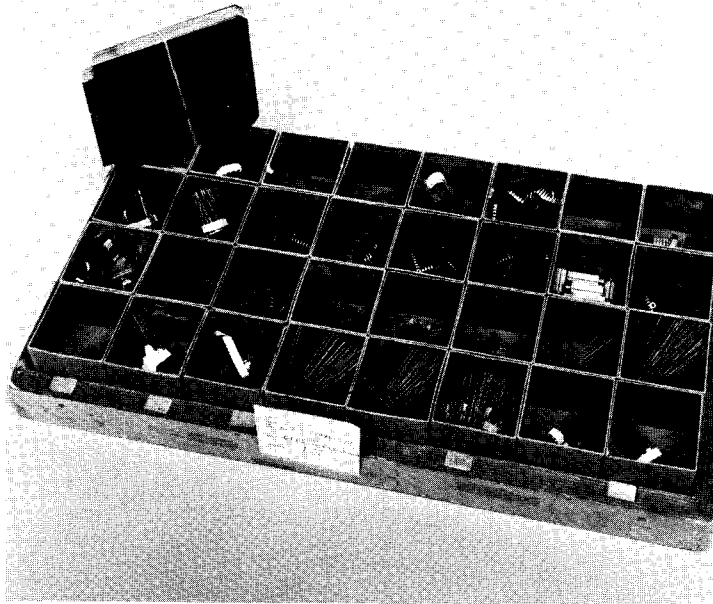
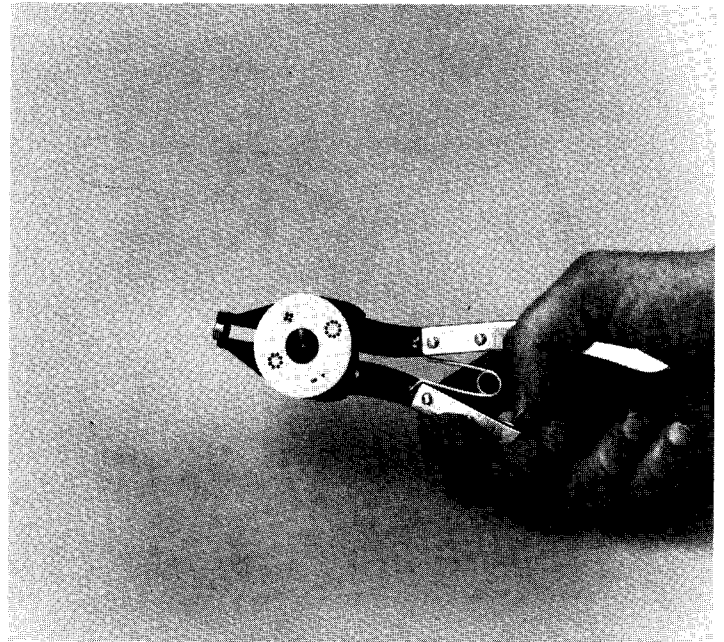
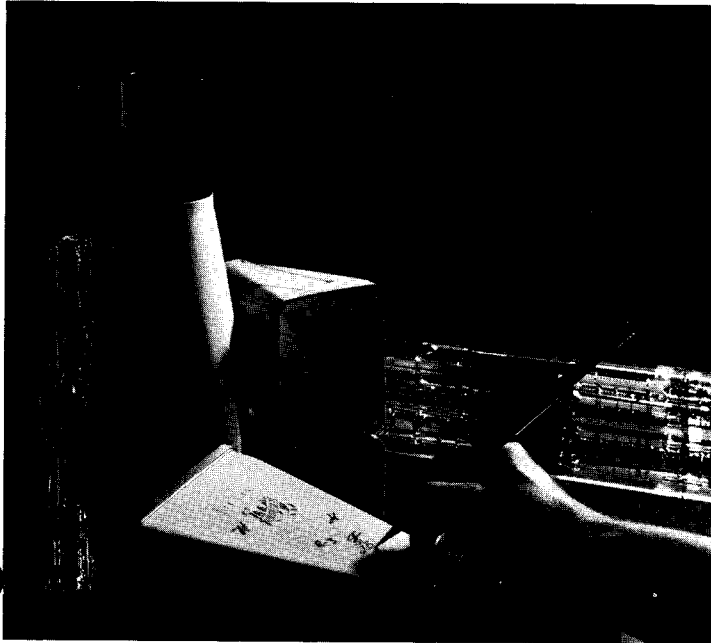

TABLE OF CONTENTS

DAS9100 EXTERNAL CLOCK PROBE THRESHOLDS 1
GMA101A/GMA102A/GMA103/618/4054/4114 NEW HARD COPY BOARD MODIFICATION 44944 . 1
OF150 ACCESSORY FIBER OPTIC CABLES BREAKING -- WARNINGS 2
OF150 LASER DIODE FAILURE (B010100 TO B010200). 5
S3200 PRAM SPARES 5
TSG6 SWITCH CONTACT PITTING 7
TV MANUAL REVISIONS (SEPTEMBER) 7
TV MANUAL REVISIONS (OCTOBER) 7
7B53A/7B53AN, TV TRIGGERING IMPROVEMENT 8
49X W.L. GORE CABLE PRECAUTIONS 8
380 MANUAL CHANGE 8
381 SPECIFICATION CHANGES 8
492/P START SPUR & MIXER BIAS ADJUSTMENT PROCEDURE.11
607(A) DEFLECTION AMPLIFIER FOIL LAYOUT ERROR12
634 F662 FUSE SELECTION12
634 HIGH VOLTAGE SHIELD SCREWS.12
634 HIGH VOLTAGE TRANSFORMER MODIFICATION 5227512
650HR SERIES CONDUCTED INTERFERENCE13
1450 FREQUENCY RESPONSE TILT WITH TEMPERATURE18
2445/2465 POTENTIAL RELIABILITY PROBLEM18
4054/4054A Q5001 AND Q5002 MODIFICATION18
4054/4054A SCREWS CPU SANDWICH TO FRAME ASSEMBLY.19
4112B/4113B PART NUMBER CHANGES20
4115B INTERMITTENT DISPLAY VIDEO.20

DAS9100 EXTERNAL CLOCK PROBE THRESHOLDS

Affected Units: All DAS9100's

A common operator trap occurs when varying the thresholds of the DAS external clock probe. This happens because the variable threshold for the probe affects all of the probe's inputs, not only the targeted input.

The most common occurrence of this trap occurs when attempting to drive the Pattern Generator with an external clock under the following conditions:

- o The threshold for the pattern generator external clock is less than 0.0 volts.
- o The "Pause on" or "Inhibit on" fields are left at their default settings of 1.

Under these conditions, the unused "Pause On" and "Inhibit On" inputs are seen as high logic levels and cause the pattern generator to both "pause" and "inhibit".

Again, the important thing to remember is when varying the threshold of a single clock or control line on the external clock probe, it affects the threshold of all inputs of that probe.

W2 Issue 13-23

GMA101A/GMA102A/GMA103/618/4054/4114
NEW HARD COPY BOARD MODIFICATION 44944

A new hard copy amplifier board is being used in the GMA101A, GMA102A, 618, 4054, and 4114. This new board, part number 670-7550-00, is identical to that now used in the GMA103, 4054 Option 31, and 4114 Option 31 products. It requires the use of the INTER-0 signal present at the backpanel hard copy connector, therefore the hard copy connector cable assembly is also changed. The addition of a potentiometer (R210, sample timing) requires that the plastic hard copy amplifier cover be changed as well.

The new board "reads" the CRT target only when a target response is most expected. This reduces the noise produced in the hard copy, especially with CRT targets exhibiting substantial backswing (see the timing diagram). The strobe window can be adjusted with R210, hard copy sample timing. Typically, R210 can be set to midrange and forgotten. Noisy copies may be improved by straying from midrange either clockwise or counterclockwise.

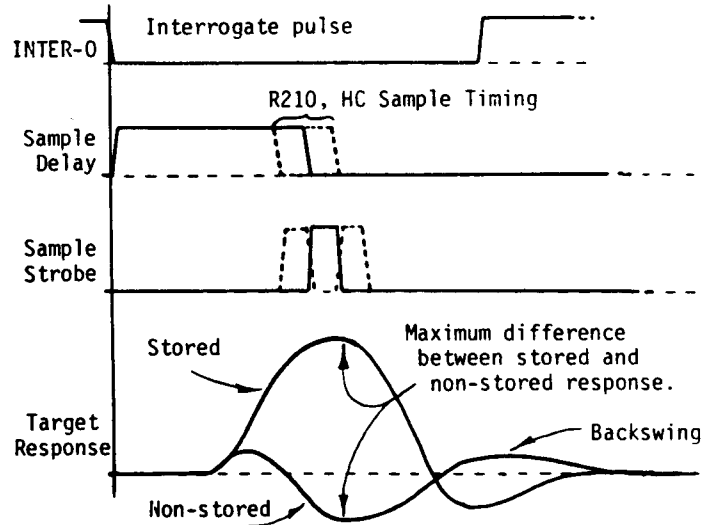

Fig. 1: Strobed Hard Copy Board Timing Diagram

Schematics of the new board and hard copy cable assemblies are given in Figures 2 and 3. Note that the added circuits around U215 (sample timing delay) and U115 (sample strobe) distinguish this board from the earlier 670-3097-XX hard copy board. Note also that the INTER-0 signal produced by the hard copy unit is routed directly to the hard copy board to trigger the strobe. The HCS-1 signal produced on the storage board and necessary with the earlier 670-3097-0X is no longer used.

(ARTICLE CONTINUED ON THE NEXT PAGE)

GMA101A/GMA102A/GMA103/618/4054/4114
NEW HARD COPY BOARD MODIFICATION 44944
(CONT.)

The following are approximate effective serial numbers for this change:

GMA103	B010230
618	B013550
GMA101A	B043979
GMA102A	B065795
4054	Not available
4114	B022400
4114 Opt. 31	B021350

Three kits have been set up to retrofit the strobed hard copy board into earlier products. These kits should be used only when needed to improve the hard copy quality, especially the ring of noise commonly seen in the center of the copy.

<u>Kit</u>	<u>Contents</u>
040-1064-01 (for 618, GMA101A GMA102A, GMA103)	1 - 670-7550-00 H.C. Board 1 - 179-2876-00 H.C. Cable Assy 1 - 200-2357-03 H.C. Board Cover 2 - 129-0457-00 Spacer Post
040-1061-01 (for 4114)	1 - 670-7550-00 H.C. Board 1 - 179-2877-00 H.C. Cable Assy 1 - 200-2357-03 H.C. Board Cover
040-1109-00 (for 4054)	1 - 670-7550-00 H.C. Board 1 - 179-2879-00 H.C. Cable Assy 1 - 200-2357-03 H.C. Board Cover

(FIGURES 2 AND 3 ARE ON THE NEXT TWO PAGES)

W2 Issue 13-8

OF150 ACCESSORY FIBER OPTIC CABLES
BREAKING -- WARNINGS

Due to premature failures of the OF150 Accessory Cable, P/N 175-4572-00, Manufacturing discovered that the red protective cap installed on each connector was the cause. To prevent any further failures the vendor, Deutch, redesigned the protector cap. These caps are provided by Deutch with the Fiber Optic Lens Assembly.

There are presently three basic designs being provided for this protective cap.

1. Thin Red Plastic Cap
1" long with no inner ridge
2. Thin Red Plastic Cap
2" long with no inner ridge
3. Thick Red Plastic Cap
1" long WITH an inner ridge

The ONLY acceptable design is number three above. With either item, number one or two, the fiber can and will break unless extreme precautions are followed. Since neither one or two have an inner ridge they can be installed on the Deutch connectors too far. This will cause the center housing of the connector to bottom out in the cap, exposing the fiber. This will cause the fiber to break upon installation of the cap or when the connector hits something. The third design has an inner ridge, within the plastic cap, to prevent installing the cap too far on the Deutch Connectors. This will prevent the bare fiber from being exposed since the center spring loaded housing never has a chance to bottom out.

Please check all accessory cables used with the OF150 and insure that they only have the new protective caps installed. If not, then DISCARD any and all caps that do not have the inner ridge.

The part number for the new protective cap is 200-2975-00. Order sufficient quantities of these protective caps to fulfill your needs.

W2 Issue 13-23

OF150 ACCESSORY FIBER OPTIC CABLES
BREAKING -- WARNINGS (CONT.)

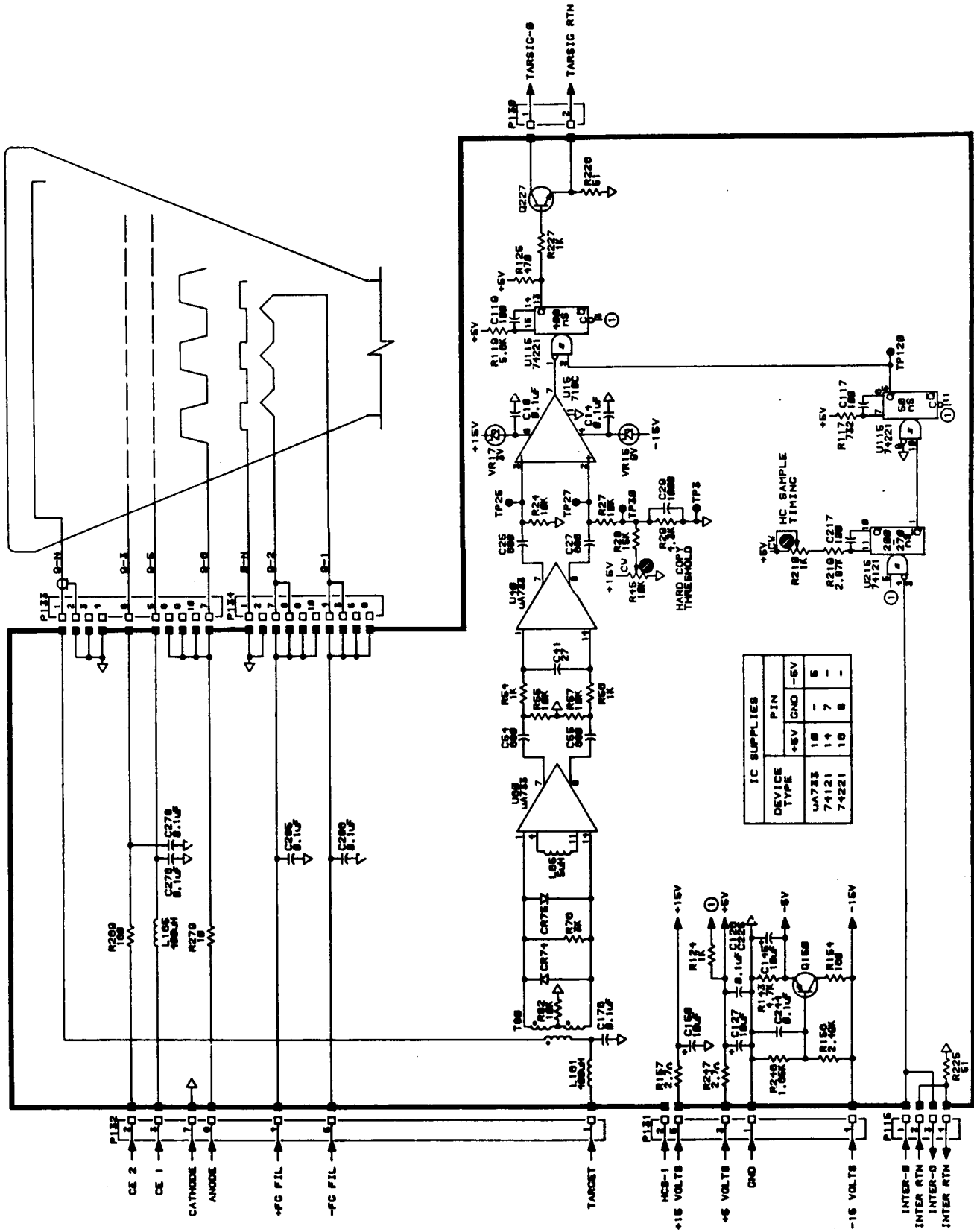
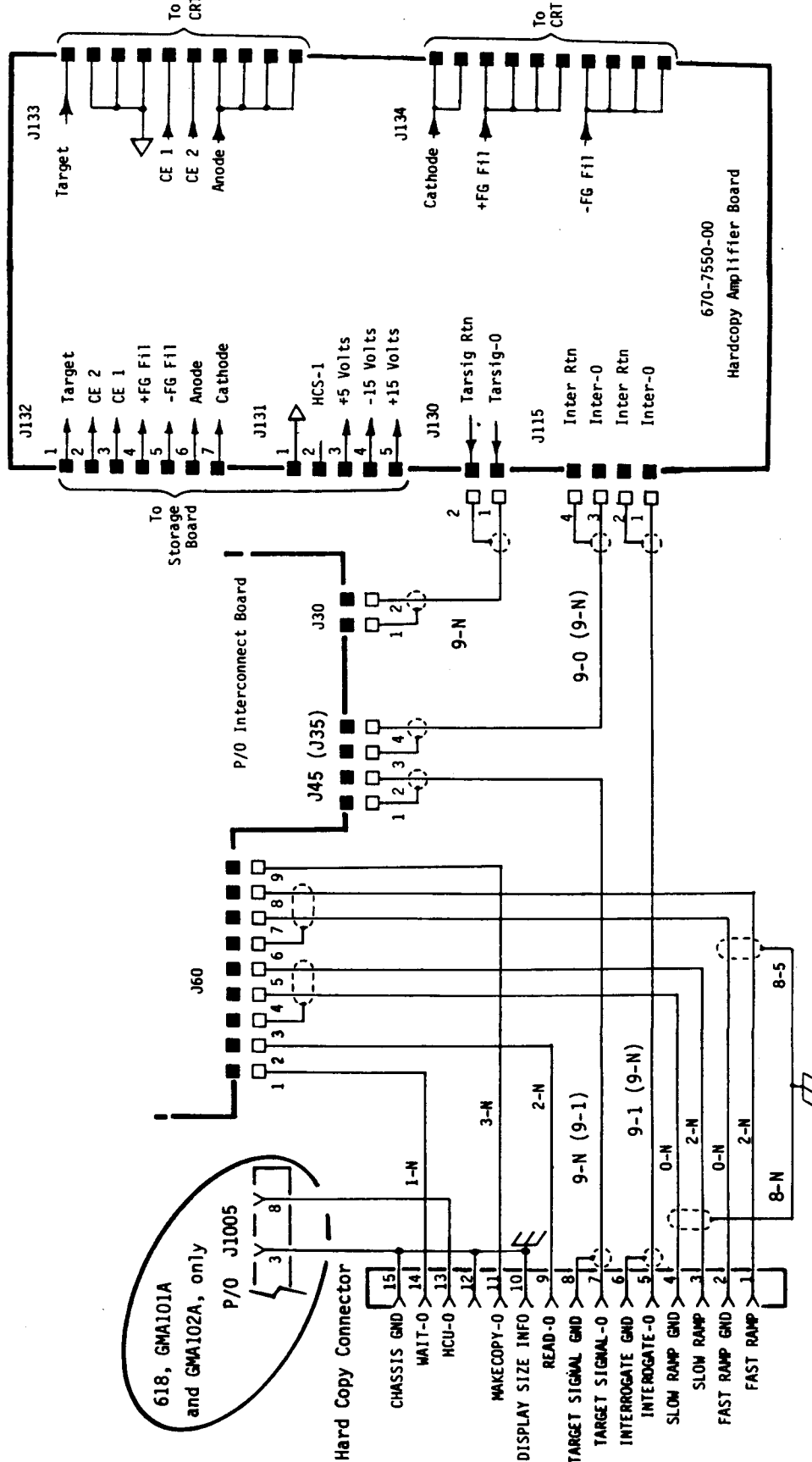

Figure 2

Schematic of 670-7550-00 strobed hard copy board.

OF150 ACCESSORY FIBER OPTIC CABLES BREAKING -- WARNINGS (CONT.)



Schematic of the 179-2876-00, 179-2877-00, 179-2879-00 and CM179-2880-00 cable assemblies used with the 670-7550-00 strobed hard copy board. Numbers in parens apply to some 4054 products only.

Figure 3

OF150 LASER DIODE FAILURE
(B010100 TO B010200)

REF: M46436

Because of an excessive failure rate of Laser Diodes in the Coupler Assemblies of early OF150's, it is imperative that all instruments within the serial number range of B010100 to B010200 entering the Service Center have the installation of the following mod physically verified.

Description of Mod is on the following page.

If the mod is found to be missing, then it is very important that it be installed.

W² Issue 13-22

S3200 PRAM SPARES

1K and 4K pram, Tektronix recommended spares

Pram spares are listed in two levels. Level 1 spares are the minimum Tektronix recommended spares. The items identified by an asterisk (*) are required for maintenance agreement spares discount credits. Level 2 spares have been identified for additional support at the system site. Level 2 spares are highly recommended for coverage of more than one system.

1K pram, Level 1

<u>QTY.</u>	<u>PART NUMBER</u>	<u>DESCRIPTION</u>
-------------	--------------------	--------------------

- | | | |
|-----|-------------|-------------------------------|
| 1 * | 119-0873-XX | Power Supply 2V, 6A |
| 1 * | 119-0916-XX | 5V, 30A Power Supply |
| 5 | 156-0761-00 | Microcircuit 1024X1 RAM |
| 1 * | 670-4838-XX | Piggyback, connector board #1 |

1 * 672-0618-XX
Controller Assembly

1 * 672-0625-XX
Error Logic Assembly

1K Pram, Level 2

<u>QTY.</u>	<u>PART NUMBER</u>	<u>DESCRIPTION</u>
-------------	--------------------	--------------------

1	672-0610-XX	Input/Output Assembly
---	-------------	-----------------------

1	672-0611-XX	1K Memory Assembly
---	-------------	--------------------

4K Pram, Level 1

<u>QTY.</u>	<u>PART NUMBER</u>	<u>DESCRIPTION</u>
-------------	--------------------	--------------------

1 *	119-0873-XX	Power Supply, 2V, 6A
-----	-------------	----------------------

1 *	119-0916-XX	5V, 30A Power Supply
-----	-------------	----------------------

5	156-1227-01	Microcircuit 4096X1 RAM
---	-------------	-------------------------

1 *	670-4838-XX	Piggyback, connector board #1
-----	-------------	-------------------------------

1 *	672-0618-XX	Controller Assembly
-----	-------------	---------------------

1 *	672-0625-XX	Error Logic Assembly
-----	-------------	----------------------

4K Pram, Level 2

<u>QTY.</u>	<u>PART NUMBER</u>	<u>DESCRIPTION</u>
-------------	--------------------	--------------------

1	672-0610-XX	Input/Output Assembly
---	-------------	-----------------------

1	672-0769-XX	4K Memory Assembly
---	-------------	--------------------

W² Issue 13-23

OF150 LASER DIODE FAILURE (B010100 TO B010200) (CONT.)

1. To top of Optical Pulse Generator Circuit Board Assy 670-7153-00, add a 15 uf capacitor (C2020) with the positive lead at the +5V end of a 100K resistor (R2024). Connect the negative lead of C2020 to the anode lead of an added diode (CR2012) and connect cathode lead of diode (CR2012) to junction of 12K resistor (R2012) and the emitter of transistor Q2018.

Connect an added diode (CR2010) and added 100K resistor (R2010) in parallel and connect the cathode end of pair at the junction of the negative lead of 15 uf capacitor (C2020) and anode lead of diode (CR2012).

Connect the anode lead of diode (CR2010), which is paralleled with resistor R2010, to the ground lead of a 100K resistor (R2014).

2. On back of the same circuit board assembly, add a .1 uf capacitor (C3020) between junction of a 360Ω resistor (R3022) and a 1.37K resistor (R3024) and the ground lead of a 20K resistor (R3027).

A38C2020	290-0135-00	CAP,FXD,ELCTLT:15UF,20%,20V
A38C3020	283-0111-00	CAP,FXD,CER DI:0.1UF,20%,50V
A38CR2010	152-0141-02	SEMICONV DEVICE:SILICON,30V,150MA
A38CR2012	152-0141-02	SEMICONV DEVICE:SILICON,30V,150MA
A38R2010	321-0385-00	RES,FXD,FILM:100K OHM,1%,0.125W

The above parts are located on the A38 Optical Pulse Generator board and shown on diagram 2 OPTICAL PULSE GENERATOR.

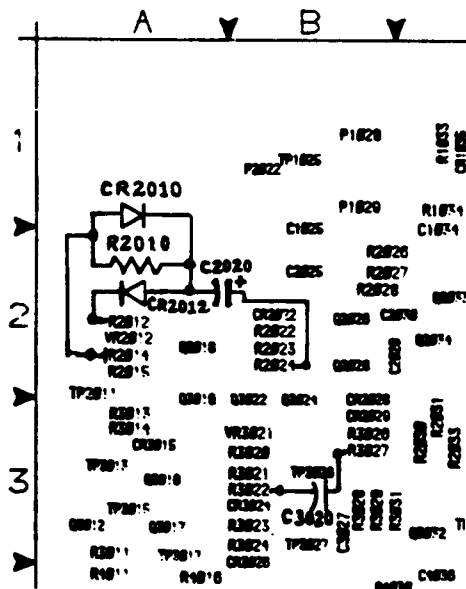

A38 —Optical Pulse Generator circuit board.

TSG6 SWITCH CONTACT PITTING

REF: TSG6 Instruction Manual
P/N 070-2528-00

A recent customer complaint about pitting of the contact under SW335 on the Multiburst Output Board, A61, 670-5508-01, suggests a possible operator trap.

When placing either the Multiburst Output Board or the Multiburst Logic Board into the 1410 Mainframe during routine servicing, it is extremely important for the technician to take the extra time and care necessary to insure that the interface pins from the mother board are correctly aligned with and inserted into the sockets on the various daughter boards.

As an example, if interface pins 0 and 1 are not correctly aligned for the TSG6 Module, and are allowed to short together, 30 volts (+15 and -15) at about 2.5 amps will be applied across two of SW335's contacts when power is applied. The resulting pitting will destroy the contacts, and require a circuit board replacement.

Use care!

W² Issue 13-22

TV MANUAL REVISIONS

The following TV Manuals have been revised or published new during the month of September, 1983.

P/N 070-4920-00
1980F04, 1980F05, 1980F06
1980 Field Update Kits, Installation Manual

P/N 070-4655-00
1980 Option 04, Operators Manual

P/N 070-3421-00
380, Instruction Manual

P/N 070-4473-00
1740 Series, Instruction Manual

P/N 070-4905-00
SPG2 Opt. AA, Manual Supplement

P/N 070-4906-00
SPG12 Opt. AA, Manual Supplement

P/N 070-4907-00
SPG22 Opt. AA, Manual Supplement

P/N 070-4908-00
TSG7 Opt. AB, Manual Supplement

P/N 070-4909-00
TSG11 Opt. AB, Manual Supplement

P/N 070-4910-00
TSG21 Opt. AB, Manual Supplement

P/N 070-1498-02
1440, Instruction Manual

W² Issue 13-22

TV MANUALS REVISIONS

The following Television Products Manuals have been revised or updated as of October 1983.

TSG3	070-2108-01
381	070-3422-00
650HR Series	070-2646-01
1910 Service	070-4523-00

W² Issue 13-24

7B53A/7B53AN, TV TRIGGERING
IMPROVEMENT

REF:

7B53A/7B53AN Instruction Manual
P/N 070-1471-00

Corporate Mod #52232

The field and line selectivity of the TV Sync Separator can be greatly improved upon by adding a capacitor from the base to collector of Q924. The cap is a 27pf., P/N 281-0513-00. Insulation sleeving 3/8 inch long cut from P/N 162-0026-00, should be used on the capacitor leads to prevent it from shorting to Q932's case.

W² Issue 13-2349X W.L. GORE CABLE PRECAUTIONS

Because of its design, the W.L. Gore cable (P/N 006-7609-00) used in the servicing of 49X and other Spectrum Analyzers, exhibits the possibility of the center pin of the connector becoming loose. To help prevent this from happening, the following precaution should be observed.

When attaching the cable to an item such as an adapter, the cable and the adapter should be prevented from turning until after the cable is firmly attached. This will prevent a rotating force being applied to the center pin which may tend to loosen the pin. The same precaution should be observed when removing the cable. Care should also be taken when installing and removing the cable on larger items such as a sweeper to ensure the cable does not rotate.

It is also recommended that, if your operation permits, you use the W.L. Gore Cable as part of a permanent set-up and in that way reduce the chance of the center pin coming loose.

W² Issue 13-24380 MANUAL CHANGEREF: 380 Instruction Manual
P/N 070-3421-00

Following on page 9 is a manual correction addressing some specification changes for the 380 NTSC Waveform Monitor/Vectorscope. Make these changes in your instruction manuals where appropriate.

W² Issue 13-22381 SPECIFICATION CHANGESREF: 381 Instruction Manual
P/N 070-3422-00

Following on page 10 is a sheet detailing specification changes for the 381 PAL Test Monitor. Make the appropriate changes in your 381 manual.

W² Issue 13-22



MANUAL CHANGE INFORMATION

Date: 22SEP83 Change Reference: C7/983

Product: 380 NTSC TEST MONITOR Manual Part No.: 070-3421-00

DESCRIPTION

Effective S/N: 301162

TEXT CHANGE

SECTION 2 SPECIFICATION, TABLE 2-1 VERTICAL SYSTEM CHARACTERISTICS, LINEAR WAVEFORM DISTORTION, Page 2-2

CHANGE TO READ:

Linear Waveform Distortion (2T)	
Loop Thru Input	
Pulse Preshoot	≤0.5% of applied pulse amplitude
Pulse Overshoot	≤1.0% of applied pulse amplitude
Pulse Ringing	≤0.5% of applied pulse amplitude
25uS Bar Tilt	≤1%
Field Squarewave Tilt	≤1%
2T Pulse to Bar Ratio	1:0.99 to 1.01. (1.0, 0.5, 0.2 VFS) 1:0.98 to 1.02. (0.1 VFS only)
Probe Input	
Pulse Preshoot	≤1.0% of applied pulse amplitude
Pulse Overshoot	≤2.0% of applied pulse amplitude
Pulse Ringing	≤1.0% of applied pulse amplitude
25uS Bar Tilt	≤2%
Field Squarewave Tilt	≤2%
2T Pulse to Bar Ratio	1:0.99 to 1.01. (1.0, 0.5, 0.2 VFS) 1:0.98 to 1.02. (0.1 VFS only)



MANUAL CHANGE INFORMATION

Date: 22SEP83 Change Reference: C4/983

Product: 381 PAL TEST MONITOR Manual Part No.: 070-3422-00

DESCRIPTION

Effective S/N: 300315

TEXT CHANGE

SECTION 2 SPECIFICATION, TABLE 2-1 VERTICAL SYSTEM CHARACTERISTICS, LINEAR WAVEFORM DISTORTION, Page 2-3

CHANGE TO READ:

Linear Waveform Distortion (2T)	
Loop Thru Input	
Pulse Preshoot	≤0.5% of applied pulse amplitude
Pulse Overshoot	≤1.0% of applied pulse amplitude
Pulse Ringing	≤0.5% of applied pulse amplitude
25uS Bar Tilt	≤1%
Field Squarewave Tilt	≤1%
2T Pulse to Bar Ratio	1:0.99 to 1.01. (1.0, 0.5, 0.2 VFS) 1:0.98 to 1.02. (0.1 VFS only)
Probe Input	
Pulse Preshoot	≤1.0% of applied pulse amplitude
Pulse Overshoot	≤2.0% of applied pulse amplitude
Pulse Ringing	≤1.0% of applied pulse amplitude
25uS Bar Tilt	≤2%
Field Squarewave Tilt	≤2%
2T Pulse to Bar Ratio	1:0.99 to 1.01. (1.0, 0.5, 0.2 VFS) 1:0.98 to 1.02. (0.1 VFS only)

492/P START SPUR & MIXER BIAS ADJUSTMENT PROCEDURE

The following procedure can be used to adjust the Start Spur (0 Hz response) amplitude and the Mixer bias.

This procedure will be incorporated in the Service Manual at a later date.

ADJUSTMENT PROCEDURE

Adjustment Start (0 Hz) Response Amplitude and Mixer Bias.

This adjustment should only be done if frequency response problems are encountered.

a. Set the FREQUENCY to 2.0 MHz, FREQ SPAN/DIV to 200 KHz, RESOLUTION BANDWIDTH to 100 KHz, REF LEVEL to -30 dBm, and activate WIDE Video Filter.

b. Connect a DVM between TP1011, on the 1st LO Driver board and ground (crt shield). Adjust R1013 for -1.0 volt.

c. Apply a calibrated -13 dBm 2 MHz signal to the RF INPUT (input to 1st mixer is now -13 dBm).

d. Activate SAVE A to save the 2 MHz, -13 dBm signal as a reference.

e. Change the FREQUENCY to 0.0 MHz to bring the start (0 Hz) response to center screen.

f. Adjust R1013 for a null in the amplitude of the 0 Hz response. (DO NOT exceed 0.1 V positive when adjusting for a null because this will degrade flatness.) Use a thin screwdriver to adjust the tuning screw on the 1st Mixer Diode assembly A12A1. (The tuning screw is towards the rear of the instrument). Alternately adjust R1013 and the tuning screw for minimum amplitude.

CAUTION

Care should be taken to not force the tuning screw past the point where it bottoms out. The null should occur about a full turn from the bottom.

g. The start (0 Hz) response should now be narrower than the 2 MHz reference signal. Turn the diode mixer tuning screw counterclockwise until the start spur response width equals the 2 MHz, -13 dBm reference. The amplitude level is now -13 dBm. This will provide the best overall flatness. Remove the 2 MHz signal from the RF INPUT and deactivate SAVE A and WIDE Video Filter.

Adjust 1st Converter Bias.

NOTE

These adjustments should only be necessary if frequency response or flatness problems on Bands 4 and 5, are encountered. Bias 1 for the fundamental bands is adjusted in the previous step.

a. Connect the DVM between TP1011, on the 1st LO Driver board, and ground. Increase the FREQUENCY Range to Band 4 (5.4-18 GHz).

b. Adjust R1022 (Bias 2) for -0.25 V at TP1011.

c. Change the FREQUENCY RANGE control to Band 5 (15-21 GHz).

d. Adjust R1026 (Bias 3) for -0.25 V at TP1011.

e. Perform the frequency response check in the Performance Check section. If the instrument fails to meet specifications, adjust the respective bias slightly from these initial settings and recheck frequency response.

607(A) DEFLECTION AMPLIFIER FOIL LAYOUT ERROR

Ref: 607A Instruction Manual, p.n. 070-2509-00

The foil pattern for the deflection board in 607 and 607A products (part number 670-3178-0X) is in error. Capacitor C382 filters the -6 volt supply and therefore has its positive terminal connected to ground. The foil layout on the board, however, indicates the opposite by having square pads on both sides of the board connect to C382's negative lead. When servicing 607(A) products, keep this error in mind and don't be misled by C832's polarity pads.

W2 Issue 13-23

634 F662 FUSE SELECTION

Ref: 634 Instruction Manual, 070-2561-00

Fuse F662 is a .3 ampere device in the 634 option 20 +5 volt supply. The part number of the fuse is 159-0029-01. Presently, Tektronix obtains this part from two different vendors; Buss and Littlefuse.

A test of 159-0029-01 stock reveals that the internal resistance of the Littlefuse part is about three times higher than that of the Buss equivalent. This higher resistance has caused low supply voltage problems in some customers' 634 option 20 applications. The sync board ramps at TP245 and TP275 will not adjust to the 7.0 volt amplitude as specified in the calibration procedure without loss of sync.

To avoid this and other problems, use only the Buss brand fuse for F662 option 20 products. When in doubt as to manufacturer, measure the fuse for a 3 to 5 ohm resistance. Do not use fuses exhibiting a higher resistance.

W2 Issue 13-22

634 HIGH VOLTAGE SHIELD SCREWS

The screws that secure the 634 high voltage shield have proven to be very secure and don't vibrate loose. In fact, they are difficult to remove. The aluminum bracket bonds to the steel thread and brute force removal of these screws can gall the aluminum and destroy the bracket's thread.

To prevent this occurrence, apply some WD-40, Liquid Wrench or other such penetrant to the screw before removal. Apply a bit of graphite or silicone grease when installing new screws or brackets.

W2 Issue 13-22

634 HIGH VOLTAGE TRANSFORMER MODIFICATION 52275

Ref: 634 Instruction Manual, P/N 070-2561-00

The 634 high voltage transformer provides the potential needed to focus the 634's CRT. Typically, the 154-0860-XX focus electrodes require 2050 to 2140 volts for proper focus with a 15 KV accelerating potential.

Of late, the 120-1195-00 transformers have provided too high a focus potential across pins 7 and 10. This has caused the front panel focus control to rest close to the counterclockwise stop. CRTs that desire a low focus potential and are mounted in 634 Option 15 products may not focus at all.

To correct the problem, mod 52275 changes the turns ratio on the high voltage transformer to reduce the focus potential. The part number of the transformer changes from 120-1195-00 to -01. The standard 634 high voltage board changes from 670-5593-04 to -05

(ARTICLE CONTINUED ON THE NEXT PAGE)

634 HIGH VOLTAGE TRANSFORMER
MODIFICATION 52275 (CONT.)

and the 634 Option 15 high voltage board changes from 670-6403-03 to -04.

Existing -00 level transformers may be used to service standard or Option 1 634 products. However, for repair of 634 Option 15 products, only the -01 level transformers should be used. As inventory of the -00 is used up, the -01 should be ordered to take its place. When CRTs are replaced in earlier 634 Option 15 products, the high voltage transformer may need replacement to provide proper focus.

W2 Issue 13-22

650HR SERIES CONDUCTED INTERFERENCE

REF: 650HR Instruction Manual
070-2646-01

635HR/656HR Instruction Manual
070-2647-00

FCC Rules, Part 15, Subpart J,
Class B Computing Device

In order to comply with new conducted interference specifications that become effective October 1, 1983 in the United States and January 1, 1985 in Europe, the 650HR Series has been modified in two specific areas.

1. The low voltage rectifier bridges (CR8340, CR8360, and CR8380) on the power supply board have been changed to P/N 152-0750-00.
2. The Mains power connector (P/N 131-1084-00) and its protective cover (P/N 200-2116-00) were replaced with a line filter unit (P/N 119-1536-00) and a new protective cover (P/N 200-1788-01).

Two new screws are used for mounting the new line filter, P/N 211-0537-00.

The new parts will be used in all 650HR's manufactured after S/N BU55254. Products manufactured before this Serial Number are exempt from the new rules.

The new rectifier bridges can be used in older 650HR's as replacements, and will provide a small increase in the electrical efficiency of the part due to reduced charge storage in the diodes.

The new line filter and protective cover can be used in older 650HR's, however, the part is not required, and is more expensive.

To insure proper replacement of the line filter, the three wires going to the device should be separated and dressed flush against three different sides of the filter body before the protective cover is pushed over the top of the assembly.

The manual changes pertaining to this modification are on the following pages. The Warning statement is per the new rules and also supplies some minimal operator information pertinent to the installation and use of the instrument.

(ARTICLE CONTINUED ON THE NEXT PAGE)

W2 Issue 13-23

TEKTRONIX MANUALS CHANGE INFORMATION

<u>Date:</u> 11-1-83		
<u>Product:</u> 653HR/656HR	<u>Manual Part No.:</u> 070-2647-00	
<u>Change Reference:</u> M52067	<u>Product Group:</u> 20	

DESCRIPTION

EFFECTIVE S/N: B055254

TEXT, PARTS LIST, & SCHEMATIC CHANGES

Page following Title pages (070-2647-00 & 070-2337-00) before Copyright; and on Page 1-1

ADD:

WARNING

This equipment generates and uses radio frequency energy and if not installed and used properly, that is, in strict accordance with the manufacturers instructions, may cause interference to radio and television reception. It has been tested and found to comply with the limits for a Class B computing device in accordance with the specifications in Subpart J of Part 15 of FCC rules. If this equipment does cause interference to radio or television reception, which can be determined by turning the equipment off and on, the user is encouraged to try to correct the interference by one or more of the following measures:

Reorient the receiving antenna.

Relocate the instrument with respect to the receiver.

Move the instrument away from the receiver.

Plug the instrument into a different outlet, so that instrument and receiver are on different branch circuits.

ELECTRICAL PARTS LIST

CHANGE TO:

A17	670-1606-05	CKT BOARD ASSY:LV & HV POWER
CR8340	152-0750-00	SEMICOND DEVICE: RECT, SI, 600V, 3A
CR8360	152-0750-00	SEMICOND DEVICE: RECT, SI, 600V, 3A
CR8380	152-0750-00	SEMICOND DEVICE: RECT, SI, 600V, 3A

ADD:

FL7705	119-1536-00	FILTER,RFI: 3A, 250 VAC, 50/60HZ
--------	-------------	----------------------------------

Product: 653HR/656HR DATE: 10-1-83 Change Reference: M52067

FL7705 is added as shown in partial diagram 18

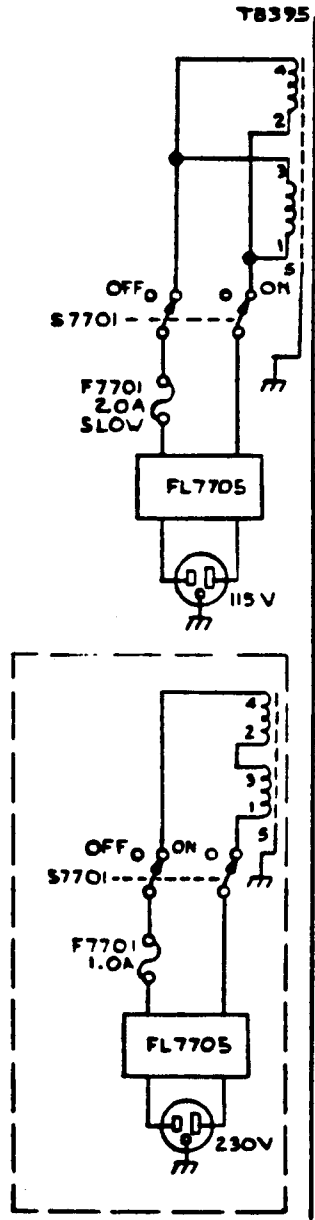

TEKTRONIX MANUALS CHANGE INFORMATION

<u>Date:</u>	<u>11-1-83</u>	<u>Manual Part No.:</u>	<u>070-2646-01</u>
<u>Product:</u>	<u>650HR Series</u>	<u>Product Group:</u>	<u>20</u>
<u>Change Reference:</u>	<u>M52067</u>		

DESCRIPTION

EFFECTIVE S/N: B055254

TEXT, PARTS LIST, & SCHEMATIC CHANGESPage following Title page, before Copyright; & on Page 1-i

ADD:

WARNING

This equipment generates and uses radio frequency energy and if not installed and used properly, that is, in strict accordance with the manufacturers instructions, may cause interference to radio and television reception. It has been tested and found to comply with the limits for a Class B computing device in accordance with the specifications in Subpart J of Part 15 of FCC rules. If this equipment does cause interference to radio or television reception, which can be determined by turning the equipment off and on, the user is encouraged to try to correct the interference by one or more of the following measures:

Reorient the receiving antenna.

Relocate the instrument with respect to the receiver.

Move the instrument away from the receiver.

Plug the instrument into a different outlet, so that instrument and receiver are on different branch circuits.

ELECTRICAL PARTS LIST

CHANGE TO:

A12	670-1606-05	CKT BOARD ASSY:LV & HV POWER (650HR, 651HR, 652HR, 655HR ONLY)
A12CR8340	152-0750-00	SEMICONV DEVICE: RECT, SI, 600V, 3A
A12CR8360	152-0750-00	SEMICONV DEVICE: RECT, SI, 600V, 3A
A12CR8380	152-0750-00	SEMICONV DEVICE: RECT, SI, 600V, 3A

CHASSIS PARTS, Page 9-71

ADD:

FL7705	119-1536-00	FILTER,RFI: 3A, 250 VAC, 50/60HZ
--------	-------------	----------------------------------

Product: 650HR - Series DATE: 10-1-83 Change Reference: M52067

FL7705 is added as shown in partial diagram 16

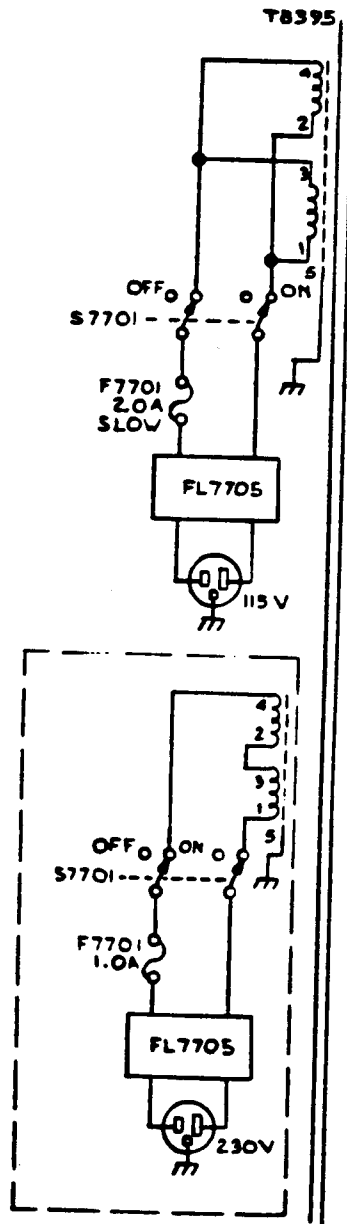

1450 FREQUENCY RESPONSE TILT WITH TEMPERATURE

REF: 1450-1 Instruction Manual
070-2200-01

1450-2 Instruction Manual
070-2998-00

1450-3 Instruction Manual
070-3660-00

To correct a problem in Frequency Response Tilt over the 1450's specified operating temperature range, R64 and R54 on the I.F. Post Amp Assy, A26 were changed.

R64 becomes a 131-0566-00, 0 ohm resistor.

R54 becomes a test selectable fixed resistor with a nominal value of 43 ohms (P/N 315-0430-00) and a range of 20 ohms to 51 ohms.

R54 is selected for best frequency response tilt over temperature. Step 10 in the 1450-1 Manual specifies the adjustment procedure for R64. Experience on the Manufacturing line has shown that a combination circuit resistance of 43 ohms will achieve the required specifications, but R54 was made test selectable to allow for those few instances where minor deviations may be encountered.

This change will help reduce problems in other areas such as power levels and transient response, that are dependent upon a flat response curve.

W2 Issue 13-23

2445/2465 POTENTIAL RELIABILITY PROBLEM

SERIAL NUMBERS: All

BOARD PART NUMBER: 670-7277-00, 01,
02, 03, 05

PROBLEM: Poor Edge Focus

SOLUTION: Replace A9C1891 (P/N: 281-0775-00; Capacitor, 0.1uF, 20% 50V) with P/N: 281-0773-00 (Capacitor, 0.01uF, 10%, 100V). Depending on where the Edge Focus potentiometer (A9R1864) adjusted, the voltage applied to A9C1891 is from 42VDC to 87VDC. Up until now, A9C1891 had only a 50 volt rating.

RECOMMENDATION: Visually check to see if the value of A9C1891 is 0.01uF. The capacitor will be marked with the number "104" or a "103". A "104" indicates 0.1uF and "103" indicates the new correct value, 0.01uF. If it cannot be determined either visually or with a capacitance meter that A9C1891 is 0.01uF (P/N: 281-0773-00) 100 volt rating, replace the capacitor with the correct part (P/N: 281-0773-00). If you install a new part please install it so the number "103" faces upwards so it can be read easily in the future. Note: Every 2445/2465 that comes in for service must have this capacitor checked for the proper value and voltage rating.

W2 Issue 13-25

4054/4054A Q5001 AND Q5002 MODIFICATION

Ref: 4054/4054A Parts and Schematics Service Manual, Part Number 070-2839-03

Corporate Modification M50121

Many 4054 products have been experiencing intermittent start-up malfunctions as well as intermittent "locked busy" failures during operation. These malfunctions are usually caused by failures on the I/O or MAS boards, with RAM failures the most predominant. These failures have been traced to poor or intermittent connection of the cables to Q5001 and Q5002. These transistors are mounted to the CPU frame and are connected to J117 and J118 on the I/O board.

(ARTICLE CONTINUED ON THE NEXT PAGE)

4054/4054A Q5001 AND Q5002 MODIFICATION
(CONT.)

The modification allows removing the contacts and housings from the transistor ends of these cables, stripping back the insulation and soldering the wires directly to the transistor legs. See schematics for details on color codes and transistor connections.

4054A's with serial number of B043200 or greater will have this modification.

W2 Issue 13-23

4054/4054A SCREWS CPU SANDWICH TO
FRAME ASSEMBLY

Ref: 4054/4054A Parts and Schematics
Service Manual, Part Number
070-2839-03

Questions have filtered in from different field personnel concerning the length and placement of the screws which hold the CPU sandwich to its frame assembly. The figure below shows the frame assembly, the screws and the holes which the screws are inserted through. Note circled alpha characters, each denote a different length screw. Following the figure is a table for cross-referencing the index character to screw length.

Note that there are two "D" type screws listed. On the 4054A this screw goes through the ALU board and into the I/O board, whereas on the 4054 it only screws to the ALU board.

(ARTICLE CONTINUED ON THE NEXT PAGE)

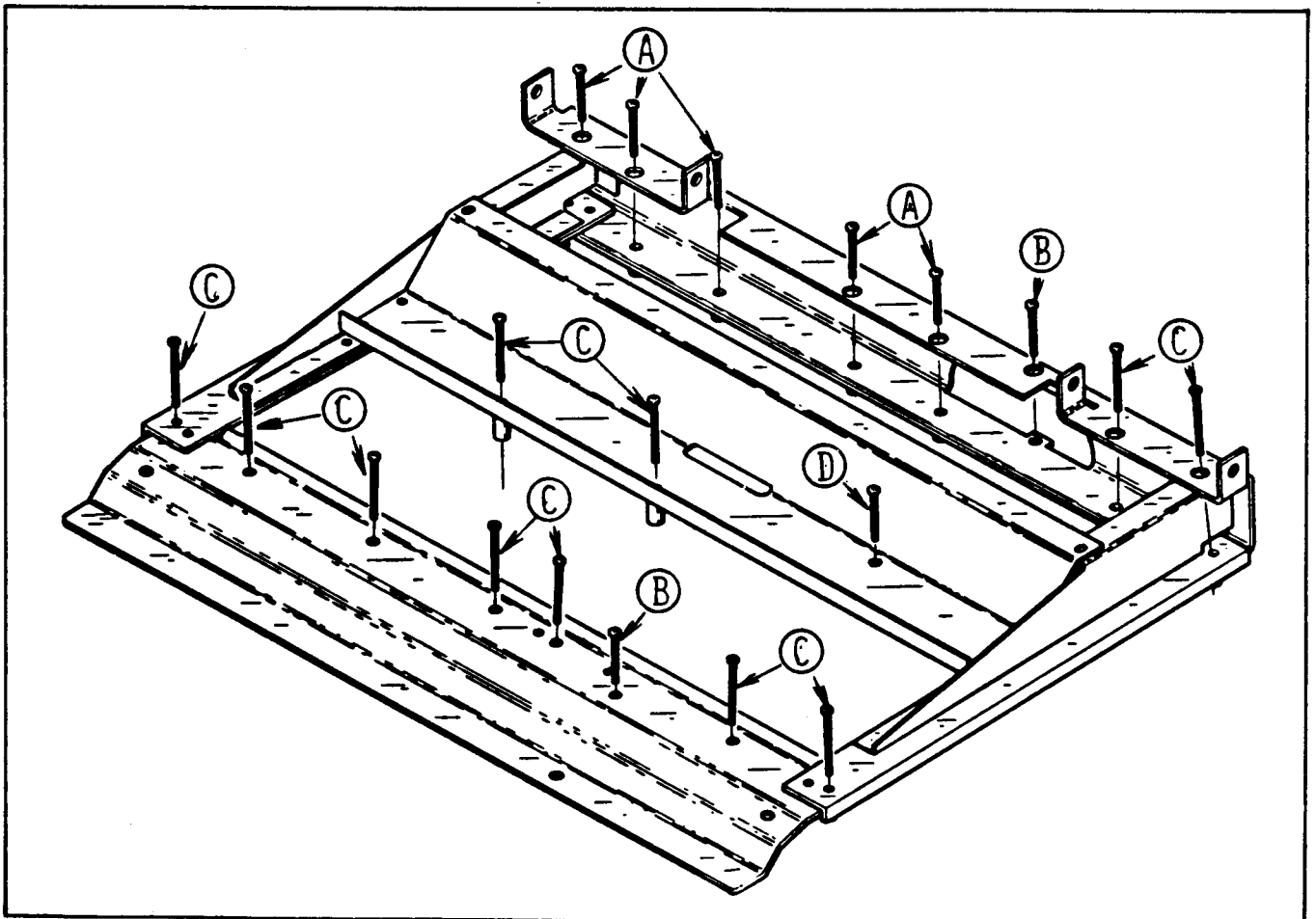

Figure 1

4054/4054A SCREWS CPU SANDWICH TO
FRAME ASSEMBLY (CONT.)

<u>Index Character</u>	<u>Screw Length</u>	<u>Tektronix P/N</u>	<u>Quantity</u>	<u>Comments</u>
A	1.375"	211-0525-00	5	4054/54A
B	1.0"	211-0517-00	2	4054/54A
C	1.5"	211-0553-00	11	4054/54A
D	0.375"	211-0559-00	1	4054 only
D	1.750"	211-0530-00	1	4054A only

Table 1

W² Issue 13-23

4112B/4113B PART NUMBER CHANGES

Changes have occurred that require some part numbers to roll from -00 to -01. Listed below are the corrections.

Processor boards are now:

4112B 672-1157-01
4113B 672-1155-01

RAM/ROM boards are now:

4112B 672-1158-01
4113B 672-1156-01

ROM changes to 4112B Processor board:

U231 160-1005-05 rolls to -06
U241 160-1004-05 rolls to -06

ROM changes to 4112B RAM/ROM board:

U61 160-0993-04 rolls to -05
U71 160-0995-04 rolls to -05
U161 160-0992-04 rolls to -05
U171 160-0994-04 rolls to -05

ROM changes to 4113B Processor board:

U231 160-1550-05 rolls to -06
U241 160-1549-05 rolls to -06

ROM changes to 4113B RAM/ROM board:

U61 160-1536-04 rolls to -05
U71 160-1538-04 rolls to -05
U161 160-1535-04 rolls to -05
U171 160-1537-04 rolls to -05

Make these changes to your manuals. This is also an addition to the Service Maintenance Information.

W² Issue 13-24

4115B INTERMITTENT DISPLAY VIDEO

When the Digital Convergence board in the 4115B display is mounted vertical for maintenance, the 3M connector P61 may become pinched causing a loss of video.

The pins at J61 are .050 inch too long and if pressure is placed on connector P61 pin two (INT GAIN) may short to a ground strap on the 3M cable. If intermittent video is experienced, relieve the pressure on P61 and reseat connector so board pins are not shorting to 3M cable.

W² Issue 13-25