

# INSTRUCTION MANUAL

**TYPE 544**  
**OSCILLOSCOPE**

*Tektronix, Inc.*

S.W. Millikan Way ● P. O. Box 500 ● Beaverton, Oregon 97005 ● Phone 644-0161 ● Cables: Tektronix

070-418

<http://manoman.sqhill.com>

364



## WARRANTY

All Tektronix instruments are warranted against defective materials and workmanship for one year. Tektronix transformers, manufactured in our own plant, are warranted for the life of the instrument.

Any questions with respect to the warranty mentioned above should be taken up with your Tektronix Field Engineer.

Tektronix repair and replacement-part service is geared directly to the field, therefore all requests for repairs and replacement parts should be directed to the Tektronix Field Office or Representative in your area. This procedure will assure you the fastest possible service. Please include the instrument Type and Serial number with all requests for parts or service.

Specifications and price change privileges reserved.

Copyright © 1964 by Tektronix, Inc., Beaverton, Oregon. Printed in the United States of America. All rights reserved. Contents of this publication may not be reproduced in any form without permission of the copyright owner.



## CONTENTS

Warranty

- Section 1      Characteristics
- Section 2      Operating Instructions
- Section 3      Circuit Description
- Section 4      Maintenance
- Section 5      Calibration
- Section 6      Parts List and Diagrams

A list of abbreviations and symbols used in this manual will be found on page 6-1. Change information, if any, is located at the rear of the manual.



Type 544

# SECTION 1

## CHARACTERISTICS

### Introduction

The Type 544 Oscilloscope is a versatile laboratory instrument designed for use with all Tektronix lettered- or 1-Series plug-in units.

### Vertical Deflection System

The plug-in unit and probe used with the Type 544 determine the overall characteristics of the vertical deflection system. Refer to Table 1-1 for the characteristics.

### Sweep Generation

**Sweep Rates (at 1X magnification)** 0.1  $\mu$ sec/cm to 5 sec/cm in 24 calibrated steps. Sweep-rate accuracy is  $\pm 2\%$  of the indicated rate.

**Sweep Magnification** Any sweep rate can be increased by expanding the center portion of the display horizontally in fixed steps of 2X, 5X, 10X, 20X, 50X, and 100X. Sweep-rate accuracy is within 5% in the magnified positions at effective sweep rates up to 10 nsec/cm.

**Trigger Source Selection** Internal normal, internal plug-in, external, and line.

**Trigger Coupling Selection** Dc, ac, and ac low-frequency rejection.

**Trigger Signal Requirements** Internal (ac): Minimum deflection is 2 mm with signals at about 150 cps, rising to 1 cm at about 50 cm.

Internal (dc): Minimum deflection is 5 mm at dc.

Internal (ac low-frequency rejection): Minimum deflection is 2 mm with signals at about 2 kc, rising to 1 cm at about 50 cm. External: Frequency ranges are the same as internal. Minimum amplitude is 200 mvolts peak-to-peak (ac), 200 mvolts change in dc level (dc), and 200 mvolts peak-to-peak (ac low-frequency rejection). A MAXIMUM INPUT OF  $\pm 30$  VOLTS must not be exceeded in the EXTERNAL trigger position. Minimum trigger level range is greater than  $\pm 2$  volts with the TRIGGER LEVEL control pushed in and  $\pm 20$  volts with the control pulled out.

### Horizontal Deflection System

The following characteristics apply when the HORIZONTAL DISPLAY switch is set to the EXT position.

**Deflection Factor** Variable in fixed steps of .1, 1, and 10 volts/cm. Accuracy is  $\pm 5\%$  when VARIABLE control is set to CALIBRATED.

TABLE 1-1

**Plug-In Characteristics for the Type 544 Oscilloscope**

Plug-In Unit	Calibrated Deflection Factor	Bandpass AT — 3 dB	Fastest Risetime	Input Capacitance
Type 1A1**	50 mv/cm to 20 v/cm 5 mv/cm	dc to 50 mc dc to 28 mc	7 nsec 12 nsec	15 pf
Type B	5 mv/cm to 0.02 v/cm 0.05 v/cm to 20 v/cm	2 cps to 12 mc dc to 20 mc	30 nsec 18 nsec	47 pf
Type CA**	0.05 v/cm to 20 v/cm	dc to 24 mc	15 nsec	20 pf
Type D	1 mv/cm to 50 v/cm	dc to 300 kc-2 mc	0.18 $\mu$ sec	47 pf
Type E	50 $\mu$ v/cm to 10 mv/cm	0.06 cps to 20 kc-60 kc	6 $\mu$ sec	50 pf
Type G	0.05 v/cm to 20 v/cm	dc to 20 mc	18 nsec	47 pf
Type H	5 mv/cm to 20 v/cm	dc to 15 mc	23 nsec	47 pf
Type K	0.05 v/cm to 20 v/cm	dc to 30 mc	12 nsec	20 pf
Type L	5 mv/cm to 2 v/cm 0.05 v/cm to 20 v/cm	3 cps to 24 mc dc to 30 mc	15 nsec 12 nsec	20 pf
Type M**	0.02 v/cm to 10 v/cm	dc to 20 mc	17 nsec	47 pf
Type N*	10 mv/cm	dc to 600 mc	0.6 nsec	50 $\Omega$ input Z
Type O*	0.05 v/cm to 20 v/cm	dc to 25 mc	14 nsec	47 pf
Type Q*	10 $\mu$ strain/cm to 10,000 $\mu$ strain/cm	dc to 6 kc	60 $\mu$ sec	Adjustable
Type R*	0.5 ma/cm to 100 ma/cm			
Type S*	0.05 v/cm and 0.5 v/cm			
Type T		Time-Base Generator Plug-In Unit		
Type Z*	0.05 v/cm to 25 v/cm	dc to 13 mc	27 nsec	24 pf

\*\*Multiple-trace plug-in units.

\*Special feature plug-in unit. See your Tektronix catalog for more information on any of these plug-in units.

## Characteristics—Type 544/RM544

Frequency Response	Dc to 400 kc (3-dB down at maximum sensitivity).
Input Characteristics	(approximately) 1 megohm paralleled by 55 pf.

### Amplitude Calibrator

Output Voltages	0.2 mvolts to 100 volts peak-to-peak in 18 steps. In addition, a 100-volt dc output is available.
Frequency	Approximately 1-kc square wave.
Output Current	5 ma squarewave available at the front-panel current loop.
Output Impedance	50 $\Omega$ in .2 to 200 mVOLTS positions. Progressively higher output impedances in the .5 to 100 VOLTS positions.
Amplitude Accuracy	Peak-to-peak amplitude accuracy is $\pm 3\%$ of indicated value when working into an impedance of 1 megohm or higher in the .5 to 100 VOLTS position. When working into a 50-ohm load, in the .2 to 200 mVOLTS positions, output amplitude is one-half of the indicated voltage. (Nominal accuracy in this case, is $\pm 3\%$ assuming the external load impedance is an accurate 50 ohms.) The 5 ma current accuracy is $\pm 3\%$ .

### Front-Panel Output Signals

+GATE OUT	At least a 20-volt peak-to-peak square-wave pulse having the same duration as the sweep. Minimum dc load resistance is 5 k.
SWEEP OUT	Approximately a 100-volt, peak-to-peak sawtooth voltage having the same duration as the sweep. Minimum load impedance is 100 k.
VERT SIG OUT	Vertical signal output connector. Output amplitude is approximately 0.4 volt per centimeter of deflection on the crt. Rise-time is 20 nsec or faster. Output is ac coupled.
External Single-Sweep Input-Signal Requirements	Requires a positive-going step or pulse of at least +20 volts with a risetime of 0.5 $\mu$ sec or faster.

### Cathode-Ray Tube

Type	T5470-31-2.
Unblanking	Dc coupled.
Accelerating Potential	10 kv.
Useable Viewing Area	6-cm high by 10-cm wide.
Focus	Vertical: 2 horizontal lines/mm distinguishable over the center 4 cm. 1.5 horizontal lines/mm distinguishable in the top and bottom 1 cm. Horizontal: 2 time markers/mm distinguishable over the middle 8 cm. 1.5 time markers/mm distinguishable in the first and tenth cm.
Construction	All glass 5-inch, flat-faced crt.
Graticule	Internal, adjustable edge lighting. 6 X 10 cm with vertical and horizontal 1-cm divisions with 2-mm markings on the center-lines.

### Power Supplies

Line Voltage	$\pm 10\%$ of nominal line voltage. (See Operating Instructions)
Line Frequency	50-60 and 400 cps*.
Power Consumption	400 watts typical.
Protection	Primary of power transformer is fused and a thermal relay is installed that interrupts power in the event of overheating.

### Mechanical

Construction	Three piece, blue-vinyl covered textured aluminum. Front panel is photo-etched and anodized. Chassis is aluminum alloy.
Net Weight	80 pounds 7 ounces

\*With line frequencies other than 50-60 cycles, a special fan modification is required; contact your local Tektronix Field Representative.

# SECTION 2

## OPERATING INSTRUCTIONS

### FUNCTIONS OF CONTROLS AND CONNECTORS

TRIGGERING LEVEL	<p>Selects the amplitude point on the triggering signal where sweep-triggering occurs. When the knob is pulled out, greater triggering range is offered for triggering on higher amplitude signals. The triggering circuit is most sensitive to small signals with the TRIGGERING LEVEL control pushed in and set to 0.</p>	HORIZONTAL DISPLAY	<p>NORMAL (X1) and SWEEP MAGNIFIER positions connect the time-base circuitry to the horizontal deflection system of the Type 544. The SWEEP MAGNIFIER positions expand the display horizontally by the amount indicated. Sweep-rate accuracy is <math>\pm 5\%</math> in the magnified positions.</p> <p>EXT position allows an external signal to drive the horizontal deflection system of the Type 544. The horizontal deflection factor is set by the EXTERNAL HORIZONTAL VOLTS/CM switch.</p>
TRIGGERING MODE	<p>AUTO STABILITY position permits normal triggering on signals with repetition rates higher than about 20 cps. With no trigger signal, or with a lower repetition rate, the time-base circuit free runs and provides a handy reference trace.</p> <p>TRIG (triggered) position permits normal triggering on all triggering signals. No trace occurs when the triggering signal is removed.</p>	EXTERNAL HORIZONTAL VOLTS/CM VARIABLE	<p>Selects the horizontal deflection factor when the HORIZONTAL DISPLAY switch is set to EXT.</p>
SLOPE	<p>Determines whether the time base is triggered on the negative- (—) or positive- (+) going slope of the signal.</p>	SINGLE SWEEP	<p>Permits single sweep operation at all settings of the HORIZONTAL DISPLAY switch except EXT.</p>
COUPLING	<p>AC position blocks the dc component of the triggering signal and allows triggering to take place only on the changing portion of the signal. With frequencies below about 30 cps, use the DC position.</p> <p>AC LF REJ position attenuates signal frequencies below about 1.5 kc, allowing the trigger circuits to respond only to higher frequencies.</p> <p>DC position permits triggering on both high- and low- (to dc) frequency signals.</p>	READY Lamp	<p>Lights when the time-base circuit is triggerable.</p>
SOURCE	<p>INT NORM position uses a portion of the signal applied to the vertical deflection plates of the crt as a trigger signal.</p> <p>INT PLUG IN position applies to multitrace plug-in units that provide a single-channel trigger signal through pin 5 of the interconnecting plug (e.g. Tektronix Type 1A1 plug-in unit).</p> <p>LINE position uses a line-frequency signal as a trigger.</p> <p>EXT position is for external triggering on a signal applied to the TRIGGER INPUT connector.</p>	HORIZONTAL POSITION VERNIER	<p>Positions the display along the horizontal axis of the crt.</p>
TIME/CM VARIABLE	<p>Selects the sweep rate of the time base.</p> <p>Provides an uncalibrated adjustment of sweep rate. The sweep rate can be slowed by a factor of at least 2.5X. An UNCALIBRATED lamp lights when the VARIABLE control is not in the CALIBRATED position.</p>	AMPLITUDE CALIBRATOR	<p>Determines the peak-to-peak voltage available at the CAL OUT connector.</p>
		5 mA Current Strap	<p>Provides a calibrated source of square-wave current. The arrow shows direction of conventional current flow (i.e. positive to negative).</p>
		POWER	<p>Toggle switch for turning the instrument on and off.</p>
		INTENSITY	<p>Controls brightness of the display.</p>
		FOCUS	<p>Used in conjunction with the INTENSITY and ASTIGMATISM controls for obtaining a well-defined display.</p>
		ASTIGMATISM	<p>Used in conjunction with the INTENSITY and FOCUS controls for obtaining a well-defined display.</p>
		TRACE ROTATION	<p>Permits horizontal alignment of the trace with respect to the horizontal lines of the graticule.</p>
		SCALE ILLUM	<p>Varies illumination of the grid lines of the graticule.</p>
		Beam Position	<p>Four neon lamps with accompanying arrows indicate the direction when the display is deflected out of the viewing area.</p>
		TRIGGER INPUT	<p>Connector for applying an external trigger signal to the time base when the SOURCE switch is set to EXT.</p>

CAUTION

A MAXIMUM INPUT OF  $\pm 30$  VOLTS MUST NOT BE EXCEEDED IN THE EXTERNAL TRIGGER POSITION.

HORIZ INPUT	Jack for applying external horizontal signal when the HORIZONTAL DISPLAY switch is set to EXT.
+ GATE OUT	Supplies a 20-30 volt square-wave pulse when the time base is operating. Pulse duration is approximately 10.5X the setting of the TIME/CM switch when the VARIABLE control is set to CALIBRATED.
SWEEP OUT	Supplies the sawtooth voltage of time base. Peak amplitude is about +100 volts.
VERT SIG OUT	Vertical signal output connector. Output amplitude is approximately 0.4 volt per centimeter of deflection.
Chopped Blanking Switch (rear panel)	Provides blanking of between-channel switching transients when using multi-channel plug-in units in the chopped mode.
External Single Sweep Reset (rear panel)	Allows remote control of resetting in single-sweep operation. See Section 1 for reset step or pulse requirements.

OPERATION

Sweep Triggering

Proper sweep triggering is essential for a stable presentation of an input signal. For a stable display, the sweep must be triggered at the same time relative to the displayed signal. Thus, the sweep must be triggered by the input signal or by some external signal that has a fixed time relationship with the displayed signal. The external trigger signal must be the same frequency or a submultiple of the input signal.

Selecting the Trigger Source

The SOURCE switch selects one of a variety of possible triggering signals. For most applications, the sweep can be triggered internally from the displayed signal. This occurs with the SOURCE switch set at NORM.

The PLUG-IN position is for plug-in units that will supply a single-channel triggering signal through pin 5 of the interconnecting plug, such as the Tektronix Type 1A1 Dual-Trace Plug-In Unit. This position is useful when operating the plug-in unit in dual-trace chopped-mode operation since the triggering signal is the same as the applied signal and is free from any between-channel switching transients.

The LINE position of the SOURCE switch internally connects a line-frequency signal to the triggering input. Line triggering is useful whenever the input signal is frequency-related to the line frequency.

To trigger the time base from an external signal, set the SOURCE switch to EXT and connect the trigger signal to the TRIGGER INPUT connector. External triggering is often used when signal tracing in amplifiers, phase-shift networks, and wave shaping circuits. The signal from a single point in the circuit can be used as the external trigger signal. With this arrangement, it is possible to observe the shaping and/or amplification of a signal at various points through the circuit without resetting the triggering controls for each new display.

Selecting Trigger Coupling

Three means of trigger coupling are available with the COUPLING switch. The different coupling positions permit you to accept or reject certain frequency components of the triggering signal.

With the COUPLING switch set at DC, the time base can be triggered with all frequency components of the triggering signal within the trigger amplifier passband, including slowly changing dc levels.

With the COUPLING switch set at AC, the dc component of the triggering signal is blocked. Also, low-frequency signals below about 30 cps are attenuated.

With the COUPLING switch set at AC LF REJ, dc and low-frequency signals (below about 1.5 kc) are rejected or attenuated. Thus, the trigger circuit will respond best to the higher-frequency components of the triggering signal.

In general, use AC coupling. However, it will be necessary to use DC coupling for very low-frequency signals. When line-frequency hum is mixed with the triggering signal, it is best to use AC LF REJ coupling so that triggering takes place only on the signal of interest (if the signal of interest contains frequency components above about 1.5 kc).

The AC LF REJ position is also useful when triggering internally from multitrace plug-in units operated in the alternate dual-trace mode (unless the plug-in unit is a Type 1A1 and the SOURCE switch is set to PLUG-IN). AC LF REJ coupling has a faster recovery time when subjected to the alternate dc levels from the multi-trace plug-in unit.

Selecting Trigger Slope

The trigger SLOPE switch determines whether the triggering circuit responds on the rising (+ setting) or the falling (— setting) portion of the triggering signal. When several cycles of a signal appear in the display, the setting of the SLOPE switch will probably be unimportant. However, if you wish to look at only a certain portion of a cycle, the SLOPE switch will help start the display on the desired slope of the input signal. Fig. 2-1 illustrates the effect of both the SLOPE and TRIGGERING LEVEL controls.

Selecting Trigger Mode

The automatic stability mode is generally more convenient. With the MODE switch set to AUTO STABILITY, proper triggering takes place after setting the TRIGGERING LEVEL control. When the triggering signal is removed, the time-base circuit automatically free runs and presents a reference display.

The TRIG position of the MODE switch should be used if the trigger signal has a very low repetition rate (below about 20 cps).

Setting Triggering Level

The TRIGGERING LEVEL control determines the amplitude point on the signal where triggering occurs.



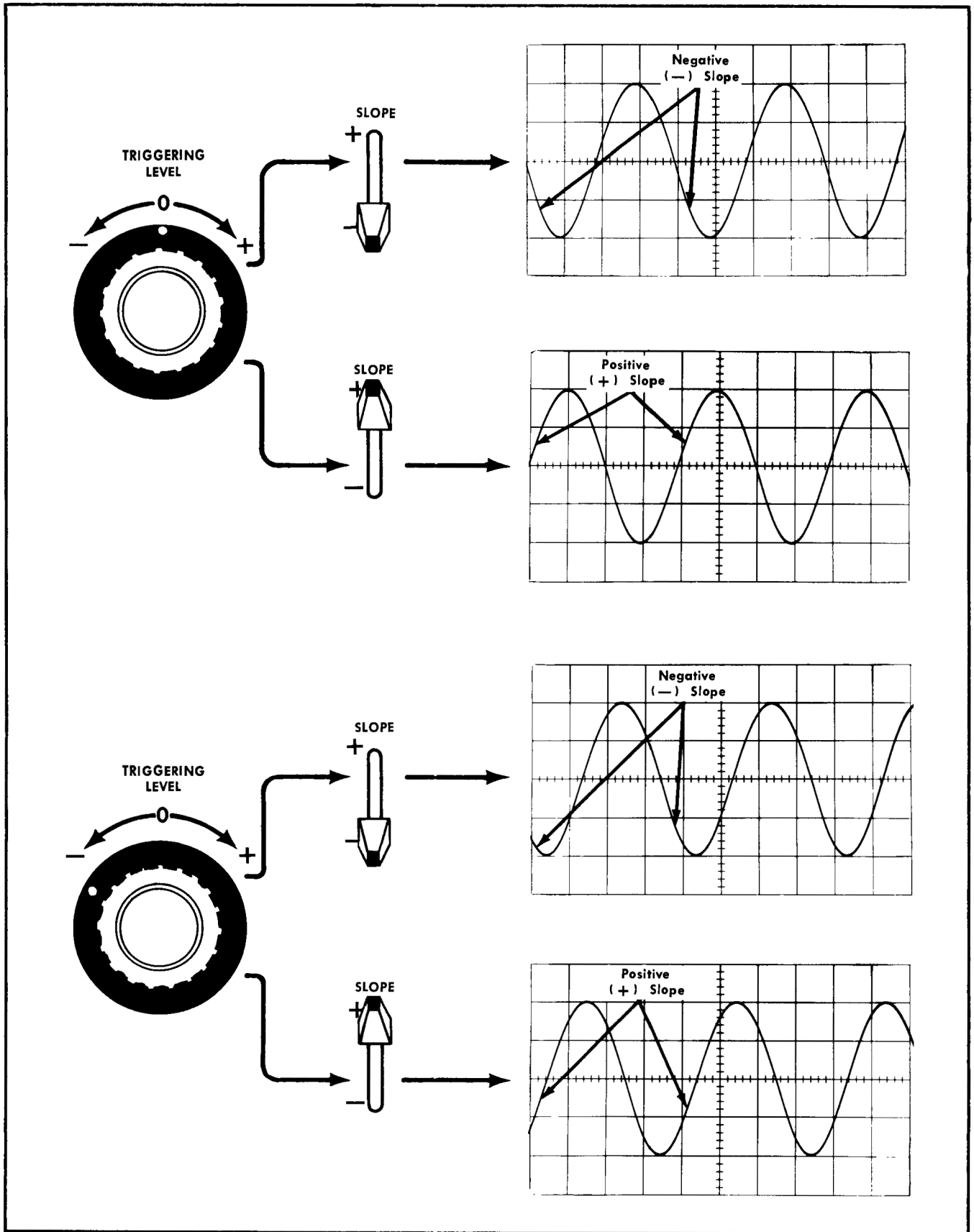

Fig. 2-1. Effects of the TRIGGERING LEVEL and SLOPE controls.

## Operating Instructions—Type 544/RM544

The trigger circuit is most sensitive to ac triggering signals with the TRIGGERING LEVEL control set near zero and pushed in. Moving the TRIGGERING LEVEL control in the + direction causes the trigger circuit to respond at a more positive amplitude on the triggering signal. Moving the TRIGGERING LEVEL control in the — direction causes the trigger circuit to respond at a more negative amplitude on the triggering signal. Fig. 2-1 illustrates the effect of the TRIGGERING LEVEL control and the SLOPE switch.

The range of the TRIGGERING LEVEL control is extended 10 times when pulled out.

### Selecting Time/Cm (Sweep Rate)

The TIME/CM and HORIZONTAL DISPLAY switches control sweep rate. The SWEEP MAGNIFIED positions expand the display horizontally by the amounts indicated.

The TIME/CM and HORIZONTAL DISPLAY switches allow you to view an applied signal at a wide variety of calibrated sweep rates. When you make time measurements from the crt, be sure the VARIABLE control is set to CALIBRATED.

When the HORIZONTAL DISPLAY switch is set to NORMAL (X1), the TIME/CM switch indicates the true sweep rate. However, with the HORIZONTAL DISPLAY switch set to X2, the setting of the TIME/CM switch must be divided by 2 to determine the true sweep rate. For example, assume that the TIME/CM switch is set at 1 mSEC and the HORIZONTAL DISPLAY is set to X5. In this case, the true sweep rate would be 1 (msec) divided by 5 (HORIZONTAL DISPLAY setting); resulting in a displayed sweep rate of 0.2 msec per division. Fig. 2-2 illustrates how to make a time measurement from the graticule.

### Single-Sweep Operation

In applications where the displayed signal is not repetitive or varies in amplitude, shape, or time, a conventional repetitive display may produce a jumbled presentation. To avoid this, use the single-sweep feature of the Type 544. To use single sweep, first make sure the trigger circuit will trigger on the event you wish to display. Do this in the conventional manner with the single-sweep switch set at NORMAL. Then depress the single-sweep switch to the RESET position and release the switch so it returns to the SINGLE SWEEP position. When this is completed, the next trigger pulse will actuate the sweep and the instrument will display the event on a single trace. The READY lamp, near the switch, first lights when the sweep is ready to accept a trigger and then goes out after triggering has taken place. To ready the circuit for another single display, depress the single-sweep switch to RESET and release. In single-sweep operation, make sure the MODE switch is set to TRIG.

## Transformer and Fan Connections

See Figs. 2-3 and 2-4 for transformer and fan connections necessary to operate the Type 544 at line voltages from 108 to 244 volts, 50 to 60 cps and 400 cps.

## Polarized Light Filter

The polarized light filter provided with the Type 544 minimizes undesirable reflections when viewing the display under high ambient light conditions. The filter may be left on when taking waveform photographs unless a high writing rate is required.

## EXTERNAL HORIZONTAL DEFLECTION

For special applications, horizontal deflection can be produced with an externally derived signal. Thus, the oscilloscope system can be used to plot one function against another (e.g. Lissajous figures). However, the system is not intended for precise phase-angle measurements.

To use an external signal for horizontal deflection, connect the signal to the HORIZ INPUT connector. Set the HORIZONTAL DISPLAY switch to EXT. The signal is dc coupled to the deflection amplifier. The EXTERNAL HORIZONTAL VOLTS/CM switch sets the horizontal deflection factor. Accuracy is  $\pm 5\%$  when the associated VARIABLE control is set to CALIBRATED.

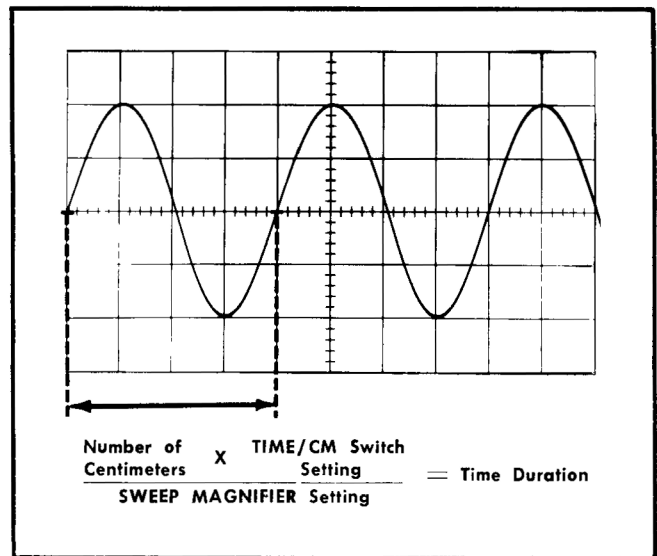

Fig. 2-2. Illustration of time measurement from the graticule.

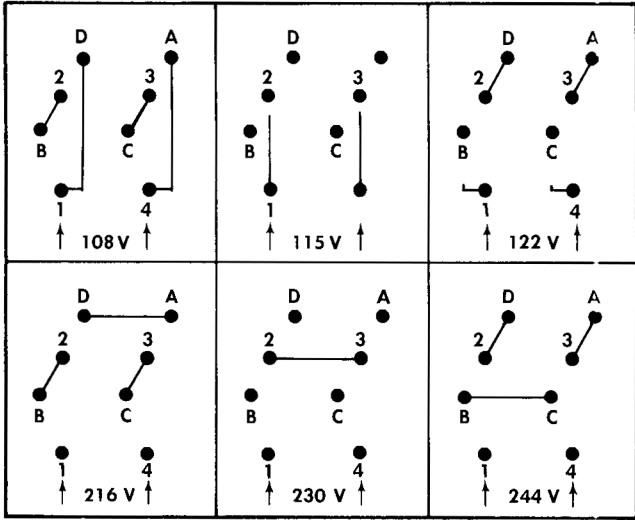

Fig. 2-3. Transformer connections for 108 to 244 volts, 50 to 60 cps and 400 cps operation.

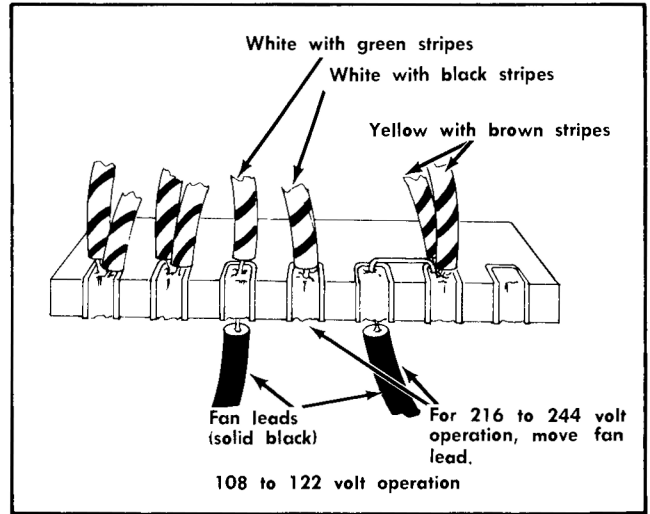

Fig. 2-4. Fan connections for 108 to 244 volts, 50 to 60 cps and 400 cps operation.

# SECTION 3

## CIRCUIT DESCRIPTION

### Introduction

This section contains the theory of operation of the various circuits in the Type 544. A simplified block diagram analysis is given first to explain the operation of each circuit in general terms, then the operation of each circuit is covered in detail.

### BLOCK DIAGRAM ANALYSIS

In the following analysis, it is assumed that the oscilloscope is equipped with a vertical plug-in preamplifier, and that the horizontal display switch is set in the NORMAL X1 position. Fig. 3-1 is a simplified block diagram showing the Type 544 operating in this mode. The functions of the various blocks in Fig. 3-1 are explained in the following paragraphs.

**Low-Voltage Power Supply.** The low-voltage power supply produces all operating voltages for the oscilloscope with the exception of parts of the crt circuit. The low-voltage supply provides regulated  $-150$ ,  $+100$ ,  $+225$ , and  $+350$  volts. It also provides heater voltages and an unregulated  $+325$ -volt output.

**Vertical Plug-In Preamplifier.** Any Tektronix letter-series or 1-series vertical plug-in preamplifier can be used with the Type 544. For a circuit description of the plug-in unit, refer to the plug-in unit instruction manual.

**Vertical Input Amplifier.** The vertical input amplifier is a balanced, hybrid amplifier that amplifies the output of the plug-in vertical preamplifier and applies the amplified vertical signal to the trigger-pickoff circuit and the vertical output amplifier.

**Delay Line.** The push-pull output of the vertical input amplifier is applied through the balanced delay line to the vertical output amplifier. The delay line is a specially braided 186-ohm line which delays the application of the vertical signal to the vertical output amplifier for 170 nsec. This provides time for unblanking the crt and starting the horizontal sweep before the vertical signal reaches the deflection plates. The delay allows the leading edge of a single fast-rising pulse to be displayed. The delay line requires no adjustment because of the precision construction.

**Vertical Output Amplifier.** The vertical output amplifier is a push-pull, three-stage, transistor amplifier that takes the output of the delay line and amplifies it to a level sufficient to drive the vertical deflection plates of the crt.

**Trigger-Pickoff Circuit.** The trigger-pickoff circuit applies a sample of the input waveform to the trigger circuits of both time bases. The trigger is picked off at the output of the vertical input amplifier.

**Time Base Generator.** The Time Base generator provides accurate ramp voltages for the horizontal deflection system, unblanking for the crt, and a  $+ GATE OUT$  to a front-panel connector. The Time Base generator may be triggered by signals derived from either internal or external sources.

**Horizontal Amplifier.** The input to the horizontal amplifier

is selected from the outputs of the Time Base generator, or the external horizontal input amplifier. The selected input is split in phase and amplified to provide push-pull drive to the horizontal deflection plates of the crt.

**External Horizontal Amplifier.** The external horizontal input amplifier provides the necessary gain to drive the horizontal amplifier from external signals. An input attenuator and a gain control provide horizontal deflection factors from 0.1 to about 10 volts/cm.

**Crt Power Supply.** The crt power supply provides the high voltages for operating the crt. The power supply is of the rf type, using a 50-kc Hartley oscillator. Secondary windings on the oscillator transformer supply voltages to the high-voltage rectifiers.

**Cathode Ray Tube (Crt).** The cathode-ray tube used in the Type 544 is a flat-faced, internal graticule, 5-inch tube with 6 cm of useable vertical scan area. The tube is designed for low input capacitance to the vertical deflection plates and minimum X-axis center-to-edge defocusing.

**Calibrator.** The calibrator in the Type 544 is a multivibrator and cathode follower that provides a square-wave output with a maximum amplitude of 100 volts at a nominal 1 kc. A step attenuator permits switching the output amplitude from the front panel. In the 0.2-mvolt to 200-mvolt range, the output impedance is  $50\Omega$ .

### CIRCUIT ANALYSIS

The following circuit analysis of the Type 544 describes the operation of the various circuits in detail. While reading through the description of a particular circuit, refer to the circuit diagram being discussed (see Section 6).

#### Low-Voltage Power Supply

The low-voltage power supply in the Type 544 (see Power Supply schematic) actually consists of four interrelated supplies that operate together as a system. This system delivers filtered and regulated voltages of  $-150$ ,  $+100$ ,  $+225$ , and  $+350$  volts as well as unregulated dc voltage of  $+325$  volts. A common power transformer, T601, supplies the input power to each of the supplies, as well as heater power to time-delay relay K600 and the tubes in the oscilloscope. Unless otherwise specified, the Type 544 is shipped with T601 wired for 115-volt ac input. A connection diagram on the side of the transformer shows alternate connections for other input voltages.

The 115-volt ac input is applied to T601 through POWER ON switch SW601. Overload protection is provided by fuse F601. Thermal cutout TK601 in the primary circuit of T601 is a protective device that opens the transformer primary circuit if the temperature inside the oscilloscope rises above a safe value. TK601 resets automatically when temperatures return to normal, and to shorten the cooling time, the fan continues to run while TK601 is open (except when T601 is connected

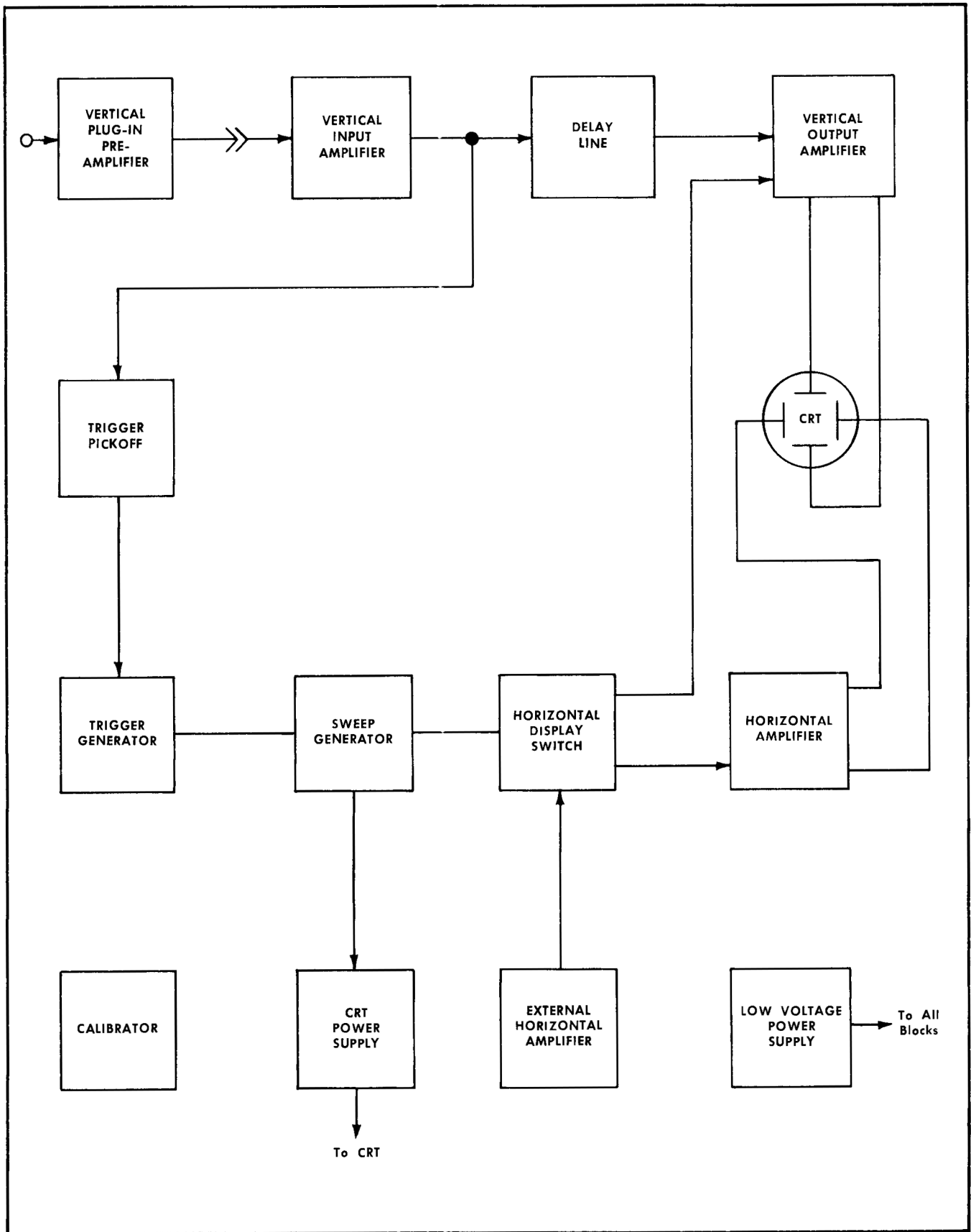

Fig. 3-1. Type 544 simplified block diagram.

for 216-244-volt operation). Thermal time-delay relay K600 provides a filament warmup time of approximately 30 seconds before the dc power supplies are activated. The heater of K600 is rated at 6 volts and is connected to 6.3 volts on the T601 secondary winding. During heater warmup time, contacts 4 and 9 of relay K600 remain open. At the end of heater warmup time, contacts 4 and 9 close and apply power to magnetic relay K601. Contacts K601-1 of relay K601 remove the heater power from K600, but before K600 can open, contacts K601-1 lock the holding circuit to the coil of K601. K601 now remains energized until the power to the oscilloscope is switched off or otherwise interrupted. When K601 is energized, contacts K601-2, K601-3, K601-4, K601-5 and K601-6 are also closed and thus activate their respective dc supplies.

—**150-Volt Supply.** The —150-volt supply in the Type 544 is the reference voltage source for the other supplies and must be very stable. The —150-volt supply includes a high-gain electronic voltage regulator designed to give good regulation under extreme operating conditions. This regulator circuit contains a series regulator, a glow-discharge tube reference source, an error detector, and an amplifier.

In operation, the input power to the —150-volt supply is supplied by one secondary winding of T601. The ac output of the secondary winding is rectified by silicon-diode rectifier bridge D642 and filtered by capacitor C642A. In series with the positive side of the supply and ground are series regulator tubes V637 and V647, paralleled by shunting resistors R646 and R647. The output of the —150-volt supply is taken from the negative side.

Error sensing in the voltage-regulator circuit is accomplished by comparator tube V624. Current flow through V624 is established by the setting of the tap on R616 in the voltage divider R615, R616, and R617. The voltage on the grid of V624A is held at approximately —85 volts by reference tube V609. Assuming that the output voltage of the —150-volt supply increases due to increased line voltage of some other cause, the voltage increase appears on the cathodes of V624 and, through the tap on R616, on the grid of V624B. Due to the voltage divider, only a part of the voltage increase appears between the grid and cathode of V624B, but the full change appears on the grid and cathode of V624A. The increase is in the negative direction, therefore, V624A increases its conduction to maintain the proper bias between grid and cathode, and this holds both cathodes more or less fixed while the grid of V624B is pulled negative by the increasing negative voltage across the voltage divider. The increasing negative voltage on the grid of V624B causes a decrease in current; thus, the plate voltage goes positive.

The positive change in plate voltage is amplified and inverted to a negative change by amplifier tube V634. The amplified error signal from V634 is applied to the grids of series regulator tubes V637 and V647. The negative-going error signal on the grids of V637 and V647 decreases the current through the tubes, effectively increasing their resistance and the voltage drop across them. The voltage necessary to provide the increased drop across the series regulator tubes and shunt resistors can only be obtained by subtracting it from the negative side of the supply, so the undesired increase in negative voltage is absorbed in the series regulators and shunt resistors. If the output of the —150-volt supply had decreased instead of increased, then the error voltage applied to the grids of the series regulators would

have been positive-going. The positive-going error voltage on the grids of the series regulators would lower the resistance of the series regulator tubes, and the voltage drop across them would decrease, leaving more voltage for the negative side of the supply. Since the output voltage of the —150-volt supply depends upon the relationship of the voltage on the tap of R616 and the reference voltage from V609, accurate adjustment of the output voltage is provided by making R616 variable.

Filter capacitor C642A does not remove all the ripple from the output of the bridge rectifier, thus the series regulator circuit also helps to reduce this output ripple voltage. Any ripple between the —150-volt output point and ground reaches the grid (pin 2) of V624A via capacitor C610. This input ripple voltage is amplified by V624 acting as a cathode-coupled amplifier. The ripple output voltage at the plate (pin 6) of V624B has the same polarity as the ripple voltage at the —150-volt output. C628 couples this ripple output voltage to the grid of V634. The ripple voltage is further amplified by V634 and applied to the grids of the series regulator tubes with a polarity that opposes the original ripple voltage. Ripple in the positive side of the —150-volt supply is coupled into a degenerative feedback loop through R637 to the screen of V634.

Some of the components in the —150-volt supply are not necessary in normal operation but are included to insure proper operation of the circuit under adverse conditions. C636 provides for proper operation of the circuit when extremely low temperatures reduce the capacitance of the electrolytic filter capacitors. R640 and R641 protect against large surge currents, and C642B suppresses sudden load changes that fall outside the bandwidth of the regulator circuit.

+ **100-Volt Supply.** The input to the +100-volt supply is the output of secondary winding 19-20 of transformer T601 and silicon diode bridge D672. In addition to its other loads, the +100-volt supply is required to supply current to a series string of filaments at all times. When the Type 544 is first turned on, relay K601 contacts are open and all the regulated supplies are inoperative. During this time, the series-string filaments are supplied by the unregulated side of the +100-volt supply through relay contacts K601-4. By the time relay K600 activates K601, the series-string filaments have reached operating temperature. When K601 is activated by K600, relay contacts K601-4 shift the series string filaments to the regulated output of the +100-volt supply.

The reference voltage source is the regulated output of the —150-volt supply. V664A is the error amplifier, V664B compensates for V664A grid-cathode contact bias changes caused by changing line voltage, and V677 is the series regulator tube. The error-feedback circuit is through R650 and R651, the junction of which is connected to the grid of V664A. The top end of R650 is connected to the regulated +100-volt output, and the lower end of R651 is connected to the output of the regulated —150-volt supply to obtain reference voltage. With normal line voltages and loads, the voltage at the junction of R650 and R651 is about —1.7 volts with reference to ground; this is the operating bias of V664A.

If the load current, output voltage, or the input voltage changes (including changes due to ripple), the output of the regulated +100-volt supply starts to change also, but any change appears across R650 and R651 and is applied to the grid of V664A as a change in operating bias. Assuming that

## Circuit Description—Type 544/RM544

the output of the regulated +100-volt supply tries to decrease, the reduced voltage at the top end of R650 permits the voltage at the junction of R650 and R651 to go more negative than the normal -1.7 volt level at that point. The increase in negative bias on the grid of V664A reduces the flow of plate current through V664A, the voltage drop across plate load resistor R663 decreases, and the plate voltage of V664 and the grid bias of V677 go more positive. As the grid of V677 goes more positive, the resistance that V677 offers to the flow of current is decreased and the output voltage rises, compensating for the drop in output voltage which initiated regulating action. Of course, the regulator circuit can never completely compensate for a change in output voltage, for there must be an error input for the circuit to operate, but any error in output is reduced by a factor equal to the loop gain of the regulator circuit.

The screen grid of V664 is used as a signal grid for injecting a sample of any ripple or transient voltages present in the unregulated side of the +100-volt supply into the regulator circuit. The regulator circuit thereby becomes a dynamic filter for ripple reduction. The ripple signal is applied to the screen of V664A, amplified and inverted in phase by V664A, then applied to the grid of V677. By the time the amplified and inverted ripple gets to the grid of V677, it is of proper amplitude and phase to cancel out the ripple appearing at the plate of V677.

To keep the proper load on the +100-volt supply when the vertical plug-in preamplifier is removed, a plug-in sensing switch is built into the main frame of the Type 544 at the top rear of the plug-in compartment. When the plug-in unit is removed, the sensing switch connects a resistive load in place of the series-filament string. When it is desired to operate the plug-in unit outside the Type 544 by means of a test harness, the sensing switch must be manually operated. To manually operate the switch, pull the plastic plunger outward to the stop position.

**Unregulated +325-Volt Supply.** The unregulated +325-volt supply voltage source differs somewhat from the voltage sources for the -150- and +100-volt supplies. A center-tapped secondary (13-14-15) on T601 and silicon diodes D702 and D732 form a center-tapped bridge rectifier circuit with the negative side connected to the positive unregulated side of the voltage source for the +100-volt supply. The unregulated +325-volt output is taken from the transformer center-tap (14) connection.

The unregulated output of the voltage source for the +100-volt supply is approximately +180 volts. The unregulated output of the center-tapped bridge circuit is approximately +290 volts; this, added to the unregulated +180 volts provides the +470 volts. However, for the unregulated +325-volt output, the connection is made at the center tap (+145 volts) of the bridge (the midpoint of the +290 volts). Adding the +180 and +145 volts provides the desired output of +325 volts.

**+225-Volt Supply.** The voltage source for the regulated +225-volt supply is the unregulated +325-volt supply described in the preceding paragraphs. The regulator circuit is similar to the regulator circuit found in the -150-volt supply; the main difference being that instead of using a glow discharge tube as a reference voltage source, the reference voltage is from the -150-volt supply. The error signal is picked off the junction of precision resistors R680 and

R681. The upper end of R680 is connected to the +225-volt output, and the lower end of R681 is connected to the regulated -150-volt supply. The voltage at the junction between R680 and R681 is approximately -0.9 volt which is applied through R682 and R683 to the grid of V684B. The cathodes of V684 are longtailed to the -150-volt supply through resistor R685. The grid of V684A is grounded. The error signal is fed from the grid of V684B through the common-cathode circuit to the A side of the tube. Notice that this comparator is somewhat different from the comparator used in the -150-volt supply; the output is taken from the A side. The error signal is amplified by V684 and fed, unchanged and in phase, to the voltage divider in the grid of V694. V694 also amplifies and inverts the error signal and applies it, out of phase with any change in the +225-volt output, to the grid of series regulator tube V707.

Here again, the screen of the error amplifier tube is acting as an injection grid for ripple reduction. A sample of the unregulated supply ripple is applied to the screen of V694. V694 amplifies the ripple, inverts it in phase, and applies it to the grid of series regulator tube V708. The result is that the same ripple appears simultaneously on the grid and plate of V707, but 180° out of phase; thus the ripple cancels out.

**+350-Volt Supply.** The input to the +350-volt supply is the full voltage output of the center-tapped bridge (see description of +325-volt supply) added to the unregulated side of the +100-volt supply. The operation of the regulator circuit is very similar to the operation of the +100-volt regulator except for different component values and no grid-cathode contact-bias compensating diode.

## Crt Circuit

The crt circuit (see Crt schematic) includes the crt, the high-voltage power supply, and the controls necessary to focus and orient the display. The crt (Tektronix Type T5470-31-2) is an aluminized, 5-inch, flat-faced, glass crt with a helical post-accelerator and electrostatic focus and deflection. The crt circuit provides connections for externally modulating the crt cathode. The high-voltage power supply is composed of a dc-to-50-kc power converter, a voltage-regulator circuit, and three high-voltage outputs. Front-panel controls in the crt circuit adjust the trace rotation (screwdriver adjustment), intensity, focus, and astigmatism. Internal controls adjust the geometry and high-voltage output level.

**High-Voltage Power Supply.** The high-voltage power supply is a dc-to-ac converter operating at approximately 50 kc with the transformer providing three high-voltage outputs. The use of a 50-kc input to the high-voltage transformer permits the size of the transformer and filter components to be kept small. A modified Hartley oscillator converts dc from the +325-volt unregulated supply to the 50-kc input required by high-voltage transformer T801. C808 and the primary of T801 form the oscillator resonant tank circuit. No provisions are made for precise tuning of the oscillator tank since the exact frequency of oscillation is not important.

**Voltage Regulation.** Voltage regulation of the high-voltage outputs is accomplished by regulating the amplitude of oscillations in the Hartley oscillator. The -1850-volt output is referenced to the +350-volt regulated supply through a voltage divider composed of R841, R842, R843, R845, R846, R847, R853 and variable resistors R840 and R846. Through a tap on the voltage divider, the regulator circuit samples the

—1850-volt output of the supply, amplifies any errors and uses the amplified error voltage to adjust the screen voltage of Hartley oscillator V800. If the —1850-volt output changes, the change is detected at the grid of V814B. The detected error is amplified by V814B and V814A. The error signal at the plate of V814A is direct coupled to the screen of V800 by making the plate-load resistor of V814A serve as the screen-dropping resistor for V800. Any change in the —1850-volt output thus changes the screen voltage of V800 and the amplitude of the 50-kc oscillations. R840 provides a means of controlling the high-voltage output through controlling oscillation amplitude.

**Crt Grid Supply.** The approximately —1950-volt output of the high-voltage power supply is the rectified output of one of the two high-voltage secondaries on T801. To provide dc-coupled unblanking signals to the crt grid, the crt grid supply is floating (the dc voltage levels on the components shift in accordance with the unblanking signals). The positive side of the crt grid supply is returned to the —150-volt supply through the unblanking cathode-follower load resistor of the selected sweep generator and through R831 and R832. The negative side of the crt grid supply is applied through the INTENSITY control to the crt grid.

At the fastest sweep rates, the stray capacitance of the floating crt grid circuit makes it difficult for the crt grid to rise fast enough to unblank the crt in the required time. An isolation network consisting of R827, R828, C828, C829, and C830 isolates the capacitive loading. By this arrangement, the fast leading edge of the unblanking pulse is coupled through C830 and C828 to the grid of the crt. For short-duration unblanking pulses, such as those that occur at the fastest sweep rates, the dc levels on the rectifier and secondary winding are not appreciably affected. Longer unblanking pulses, such as those that occur at the slower sweep rates, charge the stray capacitance in the —1950-volt output through R827. This pulls up the floating crt grid circuit and holds the crt grid at the unblanked potential for the duration of the unblanking pulse.

**+8150- and —1850-Volt Outputs.** Both the +8150- and —1850-volt outputs are derived from the same secondary winding on T801. The full secondary voltage of approximately 2900 volts is applied to a voltage tripler consisting of rectifiers V832, V842, and V852 and associated capacitors. A tap on the secondary provides the input for half-wave rectifier V862 in the —1850-volt output. Both outputs are referenced to the regulated +350-volt supply through a voltage divider network. The +8150-volt output is connected to the crt post-deflection-accelerator anode and the —1850-volt output is connected to the crt cathode, providing a total accelerating voltage of 10,000 volts.

**Crt Circuit Controls and Connectors.** Optimum size and shape of the fluorescent spot on the crt is obtained by adjusting the front-panel FOCUS and ASTIGMATISM controls. FOCUS control R846 provides the correct voltage for the second anode (focus ring) in the crt. Proper voltage for the third anode is obtained by adjusting ASTIGMATISM control R864. In order to obtain optimum spot size and shape, both the FOCUS and ASTIGMATISM controls are adjusted to provide the proper electronic lens configuration in the region of the second and third anodes of the crt. Spot intensity is adjusted by means of front-panel INTENSITY control R826. Varying the INTENSITY control changes the voltage on the crt grid, which in turn varies the density of the electron stream. Inter-

nal GEOMETRY control R861 adjusts the isolation shield voltage in the crt, and is adjusted to minimize "bowing" or "tilting" of the display. Front-panel TRACE ROTATION control R778 permits minor adjustments in trace orientation. By adjusting the TRACE ROTATION control, the trace can be made parallel with the horizontal lines on the graticule, eliminating the need to physically turn the crt to correct for minor deviations of the trace from the horizontal.

An input binding post on the rear panel of the Type 544 provides an input for externally modulating the crt cathode. The input binding post is normally grounded by a link. If it is desired to intensity modulate the display from an external source, the link is opened, and the modulating signal is coupled to the crt cathode through C858.

When the Type 544 is used with a multi-channel vertical plug-in preamplifier that provides dual-trace chopped blanking pulses, the blanking pulses are applied to rear-panel CRT CATHODE SELECTOR switch SW858. With the vertical plug-in preamplifier operating in the chopped mode and SW858 set to the CHOPPED BLANKING position, a positive pulse of approximately 20-volts amplitude is applied through C858 to the cathode of the crt. At normal intensity levels, this pulse is sufficient to cut off the crt during the time the amplifier channels in the vertical plug-in preamplifiers are being switched.

## Vertical Amplifier System

The vertical amplifier system in the Type 544 consists of an appropriate vertical plug-in preamplifier, a push-pull cathode-follower input stage, a push-pull transistorized delay-line driver, a delay line, and a push-pull transistorized output amplifier. In addition, the trigger-pickoff circuit functions as a part of the vertical amplifier by providing reverse termination for the delay line.

**Vertical Input Amplifier.** The push-pull output of the vertical plug-in preamplifier, with a fixed dc level of approximately +67.5 volts, is applied to the input of the vertical amplifier through terminals 1 and 3 of the plug-in connector.

Transient-response compensation switch SW1000, capacitor C1000, and resistor R1000 at the input of the vertical amplifier compensate for the difference in transient response that exists between different models of vertical plug-in preamplifiers. SW1000 is actuated by a mechanical sensing device when the plug-in unit is inserted into the oscilloscope, and requires no attention on the part of the operator.

R1001 and R1011, in series with the grids of the push-pull cathode-follower stage, are parasitic suppressors. Input cathode followers V1003A and V1003B are the two halves of a 12AT7 twin triode. The cathodes of the cathode followers are returned to ground through vertical dc balance control R1004, which is adjusted to equalize the dc voltage (about +68.5 volts) on the bases of delay-line driver transistors Q1014 and Q1024. The heaters of V1003 are operated as part of the series string which receives power from the +100-volt dc supply. The use of dc on the heaters prevents changes in line voltage from affecting the gain of the vertical amplifier.

The balanced delay-line driver stage is a push-pull amplifier with an adjustable vertical gain control (R1017) connected in the emitter circuit of the two transistors. Gain is adjusted by controlling the amount of degeneration in the



## Circuit Description—Type 544/RM544

emitter circuit. Zener diode D1018 sets the operating points of the termination transistors on both ends of the delay line. The  $rc$  networks in the collectors of Q1014, Q1024, Q1144, Q1154, and in the emitter leads of Q1034 and Q1044 set the individual transistor operating points to achieve thermal balance. The 5-turn center-tapped coils at the input of the delay line and the collector-base capacitance of the delay-line driver transistors form a T-section matching network. C1029 provides a means of varying the impedance of the T section.

**Vertical Output Amplifier.** The vertical output amplifier must properly terminate the delay line and provide broadband amplification of the vertical signals. Proper termination of the delay line is obtained by connecting forward-termination transistors in a common-base configuration. The common-base configuration also operates well in broadband amplifier applications. To help meet the broadband requirement, the collector load circuit of the termination transistors contains  $rc$  low-frequency compensation networks, and in addition,  $lr$  networks in the collectors of transistors Q1034 and Q1044 compensate for losses due to skin effect within the delay line.

Following the forward-termination amplifier is a wide-band amplifier stage consisting of Q1074 and Q1084 and associated elements. High-frequency compensation in this stage is provided by shunt peaking coils L1072 and L1082 in the collector circuits. The high-frequency response is varied by adjusting C1076, which provides variable high-frequency degeneration in the emitter circuit of Q1074 and Q1084.

The output stage of the vertical amplifier is a transistorized equivalent of a push-pull cascode amplifier. This circuit configuration is used to match the low impedance of the transistorized vertical-amplifier system to the higher impedance required at the crt vertical deflection plates. High-frequency compensation is provided by  $rc$  networks between the collector of the driving transistor and the emitter of the driven transistor on each side. C1105 and C1106 provide a means of varying the high-frequency response of the output stage. The outputs from Q1114 and Q1134 are connected to the deflection plates of the crt via series-peaking coils L1115 and L1135.

**Trigger-Pickoff Circuit.** The trigger-pickoff circuit provides reverse termination for the delay line as mentioned in the preceding paragraphs. The input stage of the trigger-pickoff circuit, which provides the delay-line reverse termination, is a common-base circuit. The output stage of the trigger-pickoff circuit is a push-pull emitter-follower amplifier that not only provides trigger signals to the time base, but supplies the VERT SIG OUT jack with a vertical signal and drives position-indicator amplifier V1184.

## Time Base Generator

The Time Base Generator consists of the sweep trigger and the sweep generator circuits. The sweep trigger circuit is a wide-band hybrid amplifier driving a tunnel diode. The sweep trigger circuit includes controls for selecting the type, source, and level of the trigger to be used, and circuit elements for regenerating the selected trigger into a pulse suitable for triggering the sweep generator. The sweep generator provides sweep out and +gate out signals to front-panel connectors, ramp voltages for the horizontal deflection system, and unblanking pulses to the crt.

**Trigger Generator.** The input to the sweep trigger circuit (see Sweep Trigger schematic) is selected by SOURCE switch SW201 from the trigger-pickoff circuit in the vertical amplifier, the trigger output of the vertical plug-in preamplifier, the power transformer for line triggering, or from the front-panel TRIGGER INPUT connector. COUPLING switch SW205 permits further selection of the type of triggering signal; either ac, ac with low frequencies rejected, or dc. Once the type and source of triggering signal has been selected, the slope on which triggering is desired is selected by SLOPE switch SW210. The level of the triggering signal required by the sweep trigger circuit is selected by adjusting TRIGGERING LEVEL control R215. After this triggering signal has been selected by the foregoing controls and switches, it is applied to trigger input amplifier V224.

In operation, V224A and V224B form a push-pull amplifier which drives a push-pull input, single-ended output amplifier consisting of Q234 and Q244. Tunnel diode D245 is biased at its low-voltage state (see Fig. 3-2 for trigger tunnel-diode curve) by current flow through the voltage divider consisting of R244, R245, R247, and R248. When the desired slope of the triggering signal selected arrives at the grids of V224, V224B and Q244 are biased into conduction. The conduction of Q244 increases the current flow through D245, and D245 switches to its high-voltage state. The sudden voltage change across D245 as it switches to its high-voltage state produces a uniform fast-rising trigger pulse which is used to trigger the sweep generator.

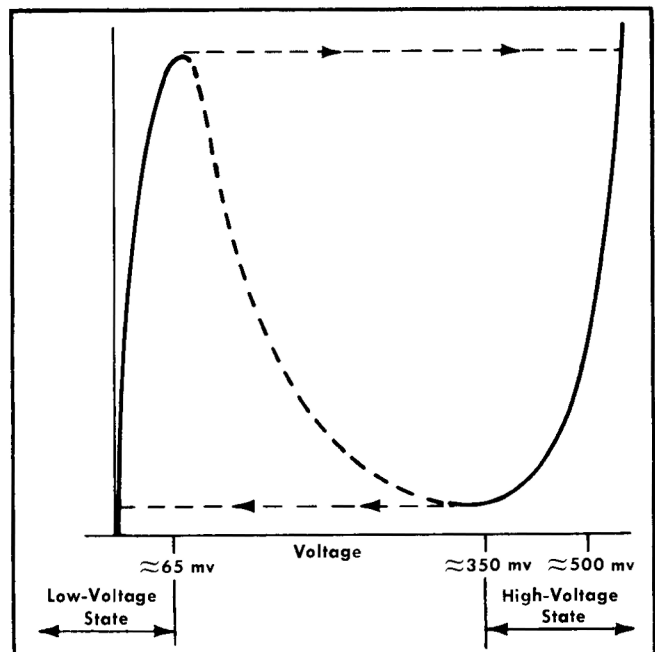

Fig. 3-2. Typical tunnel-diode characteristic curve.

**Sweep Generator.** For purposes of explanation, assume that the HORIZONTAL DISPLAY switch is in the NORMAL (X1) position, the SINGLE SWEEP switch is in the NORMAL position, and that no trigger is being applied. Under these conditions, V345B in the holdoff multivibrator is conducting and V345A is cut off. The paths for the current in V345B are from the -150-volt supply through R364 and D363 in parallel with

R363. When V345B is conducting and no trigger is being received from the trigger generator, D285 is in its low-voltage state since the dc current supplied from the +100-volt supply through R282 and R281 is less than the peak current of D285. Under these conditions, Q284 is cut off. Thus, the collector voltage of Q284 is positive, forward biasing D286, D283 and Q303. Miller tube V291 is conducting. The circuit is now ready to be triggered.

Assuming that a trigger pulse is now applied, the positive trigger from the sweep trigger circuit is coupled through C256 to L256 and D257. C256 and L256 form a differentiating network that narrows the trigger pulse to approximately 4 nsec in width. The sharpened trigger pulse passes through D259 to tunnel diode D285 and causes D285 to switch to its high state, where it remains after the trigger pulse decays to zero. When D285 switches to its high state, Q284 is biased into saturation and the voltage change across Q284 applies forward bias to Q373 and reverse biases Q289, Q303, and D286. When D286 is reverse biased, the voltage on the grid of V291 goes negative and the Miller circuit starts to run up. As the voltage on the cathode of V293A goes positive, it starts to charge timing capacitor C290 through D298. At high sweep rates, boot-strap capacitor C294 couples the rising cathode voltage to the plate circuit of V291 and effectively increases the plate supply voltage for V291, compensating for losses introduced by stray capacitance. In addition, the positive-going cathode voltage of V293A forward biases D329 and starts putting a positive voltage on the grid of V345A in the holdoff multivibrator. At a point determined by sweep-length resistor R325, the rising positive voltage biases V345A into conduction, and the holdoff multivibrator changes state, cutting off V345B. When V345B cuts off, its cathode voltage drops to -20 volts and reverse biases D285 and Q284. As current flow through Q284 ceases, the voltage increase across it again forward biases D286. When D286 becomes forward biased, it applies a positive-going voltage to the grid of V291 which resets the Miller circuit and ends the sweep.

Disconnect diode D300 ensures that the sweep starts from the same voltage point each time. Q303 is included in the circuit to reduce the amount of current that D300 has to switch, and thereby improves the linearity at the start of the sweep.

When the sweep ends, V345A has control of the holdoff multivibrator, and remains in control until the charge on holdoff capacitor C330 discharges through R330. During the time that V345A has control of the holdoff multivibrator, tunnel diode D285 cannot be triggered; but when the hold-off capacitor discharges to the point where V345B can again assume control, D285 is again biased to a point where it can accept another trigger.

**Automatic Stability Circuit.** Q265, Q275, and associated circuit components form a monostable multivibrator that controls the stability of the sweep generator. When the trigger MODE switch is in the TRIG position, the switch grounds the collector of Q275 and disables the automatic stability feature of the Type 544. When the triggering MODE switch is in the AUTO STABILITY position, the sweep generator free runs if no trigger pulses are received from the trigger generator.

In normal operation Q265 is conducting due to the positive voltage applied to its base. Q275 is normally cut off due to its base being grounded through R269. When the trigger MODE switch is set to the AUTO position, C276 starts to

charge through R276. When the voltage across C276 exceeds the breakdown of Zener diode D277, D277 breaks down and provides an additional current path for tunnel diode D285. The additional current through D285 causes it to switch to its high state and start the sweep. When the sweep ends and the holdoff multivibrator switches, the voltage on the cathode of V345B drops to approximately -20 volts, reverse biasing D285. When the holdoff period ends, the cathode voltage of V345B goes slightly positive, and the current through D277 again switches D285. If no trigger is applied, the cycle repeats only if the trigger MODE switch is in the AUTO position.

When a trigger pulse is received at T252, a negative output from the secondary is applied to the base of Q265 and causes the monostable multivibrator to switch. With Q265 now cut off, its collector voltage goes more positive, and C267 charges through R269, applying a positive voltage to the base of Q275. The positive voltage on the base of Q275 biases it to saturation, and Q275 provides a low-resistance path that discharges C276 and reverse biases D279 and D277. With the collector of Q275 below the D277 breakdown voltage, the collector circuit does not provide switching current for tunnel diode D285, so the only way D285 can be switched is by application of a trigger pulse. If no further trigger pulses are received, Q275 is kept in saturation until the charge current for C267 decays and removes the positive voltage from the base of Q275.

During the charge time of C267, Q265 is kept cut off by the forward voltage drop across D271. When the decaying charge current removes saturation bias from Q275, the voltage drop across D271 decreases and permits Q265 to conduct, and the multivibrator switches back to its normal state. If no further trigger pulses are received, C276 charges through R276 and R275 until D277 again breaks down and provides switching current for D285.

**Unblanking Circuit.** Except when the HORIZONTAL DISPLAY switch is set to the EXT positions, an unblanking pulse is generated and applied to the crt unblanking circuit during sweep time. The unblanking pulse is initiated when tunnel diode D285 switches to its high state and biases Q284 into conduction. When Q284 conducts, its collector voltage drops and removes the cutoff bias from Q373, biasing Q373 into conduction. When Q373 conducts, it puts a positive-going voltage on the grids of cathode followers V393A and V393B. The positive-going voltage on the cathode of V393B is coupled to the crt unblanking supply. The output of V393A is applied to the +GATE OUT connector on the front panel.

**Single-Sweep Circuit.** When single-sweep operation is desired, NORMAL - SINGLE SWEEP - RESET switch SW135 is set to the SINGLE SWEEP position. When SW135 is pushed to the RESET position, it operates switch SW369 which discharges C369 (see Sweep Generator schematic) through R369, R368, and R367, generating a positive pulse which is applied through C366 and D364 to the cathode of holdoff tube V345A. The positive pulse on the cathode of V345A causes the holdoff multivibrator to switch, and V345B biases sweep tunnel diode D285 to the ready point as previously explained. Since Q284 and V345A are both cut off, the positive voltage on the collector of Q284 and the voltage on the plate of V345B combine through R287 and R342 and produce turn-on bias for Q289. When Q289 conducts, it completes the circuit for the NE-23 READY lamp (B289). With the application of a trigger pulse, Q284 conducts and the voltage on its collector

## Circuit Description—Type 544/RM544

drops, removing the bias on Q289 and thereby extinguishing the READY lamp. The runup of the Miller circuit causes the hold-off multivibrator to switch, and V345A takes control. NORMAL - SINGLE SWEEP - RESET switch SW135 applies a positive voltage through D332 to the grid of V345A, and this positive voltage prevents the holdoff multivibrator from resetting until NORMAL - SINGLE SWEEP - RESET switch SW369 has been moved to either the RESET or NORMAL position.

**Sweep Timing.** The sweep rate (the rate at which the spot moves across the face of the crt) is determined by the rate at which the timing capacitor and timing resistor permit the Miller circuit to run up. By means of TIME/CM switch SW290 (see Timing-Switch schematic), both the size of the capacitor being charged and the charging current can be selected to cover a wide range of sawtooth slopes (sweep rates). Note that SW290 is connected so that switching 8 capacitors and 6 resistors provides 24 different sweep rates, varying from 5 sec/cm to 0.1  $\mu$ sec/cm without magnification. The TIME/CM switch also selects the proper holdoff capacitor and discharge resistor for the sweep rate in use.

Continuously variable uncalibrated sweep rates are provided by R290Z and SW290Z (VARIABLE control). When SW290Z is switched to the UNCAL position, it removes the short from around R290Z and switches on UNCAL lamp B290W. By turning VARIABLE control R290Z, the charging time of the timing capacitor selected by the TIME/CM switch may be increased by at least 2.5 times the calibrated rate, providing continuously variable sweep rates.

## Horizontal Amplifier

The dc-coupled horizontal amplifier (see Horizontal Amplifier schematic) consists of a transistor input amplifier, an emitter follower, a transistor paraphase amplifier, a push-pull vacuum-tube output amplifier, a pair of output cathode followers, and a capacitance-driver tube. In addition, the Type 544 contains a cathode-coupled preamplifier that is used to amplify externally applied horizontal deflection signals. The input to the horizontal amplifier is received from the sweep generator, or the external HORIZ INPUT connector, depending upon the setting of the HORIZONTAL DISPLAY switch

**Input Stages.** The selected input signal is applied to the base of Q534 along with dc-positioning voltages from the horizontal positioning controls. The composite signal output of Q534 is applied to emitter follower Q543, and from that transistor to the paraphase amplifier. Negative feedback from the emitter of Q543 to the base of Q534 keeps the input and output impedance of the two stages low. R544 (X10 CAL) in the feedback loop provides a means of adjusting the amount of feedback, thereby providing amplifier gain adjustment.

**Paraphase Amplifier.** Q554, Q564 and associated circuit components form a paraphase amplifier that splits the signal from Q543 into a push-pull output. The signal from Q554 to Q564 is coupled through the emitter circuit, and by changing the value for the coupling resistor, the gain of the paraphase amplifier is changed to provide sweep magnification. Seven selectable values of coupling resistor are available providing X1, X2, X5, X10, X20, X50, or X100 sweep magnification.

The feedback loop from the collector of Q554 stabilizes the gain and balance of the paraphase amplifier. D542 and D561 provide base-operating bias. The feedback loops from

the output cathode followers (V574B and V584B) to the emitters of Q554 and Q564 assist in stabilizing the gain of the horizontal amplifier.

**Output Amplifier and Cathode Followers.** The ramp-voltage outputs of the paraphase amplifier are applied to the grids of amplifiers V574A and V584A. The ramp voltages are amplified by the two triodes, which then apply the ramp voltages to the output cathode followers. To maintain the desired linearity at high sweep rates, part of the output from each amplifier is bypassed around the cathode followers through small variable capacitors C572 and C582. C576 and C586 together with the stray capacitance across R576 and R586 form a capacitance bridge to provide correct high-frequency feedback.

**Capacitance Driver.** The cathode of V574B drives the left-hand deflection plate and, during the sweep, the cathode voltage should go linearly in a negative direction. At high sweep rates, when V574B tries to drive the deflection plate negative, the deflection-plate capacitance and the output capacitance of cathode follower V574B tend to distort the ideal linear ramp voltage into an rc discharge curve. To overcome this tendency toward nonlinearity, the positive-going ramp voltage at the cathode of V584B is applied through C591 to the grid of capacitance driver tube V589. The positive-going voltage on the grid of V589 forces it into heavy conduction, and the current supplied through the tube provides extra current to the cathode of V574B and helps to discharge the capacitance in the output of V574B. Since the crt is blanked during the return trace, there is no need for a similar current driver at the cathode of V584B.

**External Horizontal Preamplifier.** The preamplifier applies external horizontal deflection voltages through the HORIZONTAL DISPLAY switch to the grid of V514B. For large amplitude signals, X10 and X100 attenuator positions are provided on the HORIZONTAL DISPLAY switch. V514B and V514A form a cathode-follower grounded-grid amplifier, with a gain controlled by adjusting the value of the coupling resistor between the two cathodes. In this case, R511 provides at least a 10:1 range of adjustment. The output of V514A is applied through the HORIZONTAL DISPLAY switch to the base of Q534.

## Amplitude Calibrator

The amplitude calibrator in the Type 544 is a 1-kc square-wave generator (see Amplitude Calibrator schematic) that provides both voltage and a 5-ma current output to the front-panel connectors. The voltage output is taken from the CAL OUT connector on the front panel, where either a selectable-amplitude square wave or a steady +100-volt dc reference voltage is available. By turning the AMPLITUDE CALIBRATOR switch, the amplitude of the square-wave output may be varied from 0.2 mvolts to 100 volts, peak-to-peak. The current output is applied to the 5 ma current strap. The arrow indicates conventional current flow. When the AMPLITUDE CALIBRATOR switch is in the 100 VDC position, the link has 5 ma dc flowing through it; when the switch is in the 5 mA position, the current through the link is in the form of a 1-kc, 5 ma square wave.

### CAUTION

The link is designed for use with a snap-on current probe and does not unplug.

**Square-Wave Generator.** The square-wave generator is an astable multivibrator direct-coupled to a cathode follower. V935A and V945 are the multivibrator tubes, with the screen of V945 serving as an anode and furnishing feedback to V935A. The plate of V945 operates as an electron-coupled amplifier. The time constants in the grid circuits of the tubes are different to compensate for the difference in their characteristics. When the amplitude calibrator is turned on, the multivibrator cathodes are returned directly to the dc-coupled —150-volt supply. Since the plate load and grid resistors are grounded, this means that the supply potential of the multivibrator is 150 volts. The plate of V945 operates from the +225-volt supply, but is clamped slightly above 100 volts by D942 and D948. The voltage on the plate of V945 swings from about —30 volts to about +102 volts. The plate of V945 is coupled through Zener diode D948 to the grid of cathode follower V935B. CAL AMPL control R943 is adjusted so that when the signal to V935 is positive, its cathode voltage rises

to +100 volts. When the signal from the V945 plate goes negative, V935B is cut off and the cathode voltage goes to ground potential.

**Output Level Selection.** The cathode load for V935B is essentially the string of precision resistors starting with R950 and ending with R958. The junctions of the precision resistors are connected to the CAL OUT connector through AMPLITUDE CALIBRATOR switch SW950. The values of the precision resistors are selected to give output amplitude steps in multiples of 1, 2, or 5. In the steps from 0.2 volt to 100 volts, the junctions of the precision resistors are switched through R962 to the CAL OUT connector, while in the steps from 0.2 mvolt to 0.1 volt, an additional divider with a ratio of 1000:1 is inserted between the precision resistors and the CAL OUT connector. In the 0.2 mvolt to 0.1 volt range, the output impedance is 50  $\Omega$ .

# SECTION 4

## MAINTENANCE

### PREVENTIVE MAINTENANCE

#### CAUTION

Turn off power before removing or replacing parts.

#### General Information

The Type 544 is a stable instrument and will provide many hours of trouble-free operation. However, to maintain measurement accuracy, a visual inspection and a calibration check should be made after each 500 hours of operation or every six months if used intermittently. The calibration procedures include steps for checking the operation of various circuits. Minor troubles not apparent during regular operation will often be revealed during calibration. Major troubles in the instrument are often isolated or eliminated by recalibrating the instrument.

#### Visual Inspection

The Type 544 should be inspected occasionally for such defects as broken connections, broken or damaged ceramic strips, improperly seated tubes or transistors, and heat damaged parts.

The remedy for most visible defects is obvious; however, particular care must be taken if heat-damaged parts are detected. Overheating is usually only a symptom of trouble. For this reason, it is essential to determine the actual cause of overheating before the heat-damaged parts are replaced; otherwise, the damage may be repeated.

#### Cleaning

The Type 544 must be cleaned as often as operating conditions require. Accumulations of dirt in the instrument can cause overheating and component breakdown. Dirt on the components acts as an insulating blanket (preventing efficient heat dissipation) and provides conducting paths for electricity. Dirt in the air filter chokes the flow of cooling air and leads to excessive operating temperature.

**Air Filter.** The air filter should be visually checked every few weeks and cleaned if dirty. More frequent inspections and cleaning are required under severe operating conditions. To clean the filter, wash it out as you would a plastic sponge. Rinse the filter, and let it dry. Coat the dry filter with fresh "Filter-Kote" (Tektronix Part Number 006-580) or "Handi-Koter." (These products are available from the local representative of the Research Products Corporation, and from some air-conditioner suppliers.) Let the filter dry thoroughly before reinstalling.

**Exterior.** Loose dust accumulating on the outside of the Type 544 can be removed with a cloth or small paint brush. The paint brush is particularly useful for dislodging dust on and around the front-panel controls. Stubborn dirt can be removed with a soft cloth dampened in a mild solution of water and detergent. Abrasive cleaners should not be used.

Clean the face of the crt with a soft, lint-free cloth dampened with denatured alcohol.

**Interior.** Although the air entering the Type 544 is filtered, some dust will eventually penetrate into the interior of the instrument. This dust should be removed occasionally due to its conductivity under high humidity conditions. The best way to clean the interior of the equipment is to first carefully vacuum all accessible areas and then blow away the remaining dust with dry low-pressure compressed air. Avoid the use of high-velocity air which might damage some of the components. Remove stubborn dirt with a soft paint brush or a cloth dampened with a mild water and detergent solution.

Pay special attention to the high-voltage circuits, including parts inside the high-voltage shield. Arcing in the high-voltage circuits due to dust or other causes may produce false sweep triggering resulting in an unstable crt display.

#### Lubrication

The fan motor bearings should be lubricated every three or four months with a few drops of light machine oil (see Fig. 4-1). Failure to lubricate the bearings periodically can cause the fan to slow down or stop.



Fig. 4-1. Fan motor lubrication points.

## CORRECTIVE MAINTENANCE

### General Information

Many components in the Type 544 are mounted in a particular way to reduce stray inductance and capacitance. While removal or replacement procedures for most parts in the Type 544 are obvious, remember to duplicate lead length, lead dress, and location of the original component when installing replacement parts. Since components of the same type may exhibit slightly different characteristics, it is desirable to check the calibration of the Type 544 after completion of repairs.

### Component Numbering

The component number of each electrical part is shown on the circuit diagrams. The following chart lists the component numbers associated with each circuit.

- 200-series numbers—Sweep Trigger Circuit
- 300-series numbers—Sweep Generator Circuit
- 500-series numbers—Horizontal Amplifier Circuit
- 600- and 700-series numbers—Low-Voltage Power Supply
- 800-series numbers—Crt Circuit
- 900-series numbers—Calibrator
- 1000- and 1100-series numbers—Vertical Amplifier

### Soldering Precautions

In the production of Tektronix instruments, a special silver-bearing solder is used to establish a bond to the ceramic terminal strips. This bond may be broken by repeated use of ordinary tin-lead solder, or by excessive heating of the terminal strip with a soldering iron. Occasional use of ordinary 60-40 solder will not break the bond unless excessive heat is applied, but it is advisable to stock solder containing about 3% silver for the maintenance of Tektronix instruments. This solder may be purchased directly from Tektronix in one-pound rolls; order by Part Number 251-514.

Because of the shape of the ceramic-strip terminals, it is recommended that a soldering iron with a wedge-shaped tip be used. A wedge-shaped tip allows the heat to be concentrated on the solder in the terminals and reduces the amount of heat required. It is important to use as little heat as possible while producing a full-flow joint.

The following procedure is recommended for removing or replacing components mounted on ceramic strips:

1. Use a 50- to 75-watt soldering iron.
2. Tin the tip with solder containing about 3% silver.
3. Use long-nose pliers for a heat sink. Attach pliers between the component and the point where heat is applied.
4. Apply heat directly to the solder in the terminal without touching the ceramic. Do not twist the iron in the notch as this may chip or break the ceramic strip.
5. Apply only enough heat to make the solder flow freely.
6. Do not attempt to fill the notch on the strip with solder; instead apply only enough solder to cover the wires adequately and form a small fillet on the wire. Over-

filling the notches may result in cracked terminal strips. If the lead extends beyond the solder joint, clip the excess as close to the joint as possible. Remove all wire clippings from the chassis.

### Tubes and Transistors

Tubes or transistors should not be replaced unless they are actually defective. If they are removed and found to be acceptable, be sure to return them to their original sockets. Tube or transistor-tester checks on the tubes or transistors used in the Type 544 are not recommended. Testers may indicate a tube or transistor to be defective when it is operating satisfactorily in a circuit, or may fail to indicate defects which affect the performance of the circuits. It is recommended that tubes and transistors be checked by substitution. If the tube or transistor is good, return it to its socket. Unnecessary replacement is not only expensive but may also result in needless recalibration of the instrument.

When installing replacement transistors on heat sinks in the instrument, the bottom of the transistor where it contacts the heat sink should be coated with silicone grease. If a heat sink has been replaced along with the transistor, then that area of the heat sink which contacts the chassis of the instrument should also be coated with silicone grease.

### Wafer Switches

Individual wafers are normally not replaced in the switch assemblies. If one wafer is defective, the entire switch assembly should be replaced. Switches can be ordered from Tektronix either wired or unwired. For wired and unwired part numbers, refer to the parts list in Section 6.

The wafer switches shown on the schematics are coded to indicate the position of the wafer on the switch. The wafers are numbered from front to rear (i.e., the number 1 wafer is always closest to the front panel). The letters F and R indicate the front or rear of the wafer. For example, a code designation of 3R means the rear side of the third wafer from the front panel.

### Cathode-Ray Tube

To remove and replace the cathode-ray tube, perform the following procedure:

#### WARNING

**Be careful when handling a crt. Avoid striking it on any object that might cause it to crack and implode. Flying glass from an imploding crt can cause serious injury. Use safety glasses or a plastic face mask for protection.**

1. Remove the crt bezel nuts, bezel, and plastic polarized light filter (see Fig. 4-2).
2. Remove plastic eyebrow and retaining spring from the top of the crt.
3. Remove crt anode lead, disconnect all leads to the neck of the crt.

#### NOTE

**Do not disconnect the crt trace-rotation coil leads.**

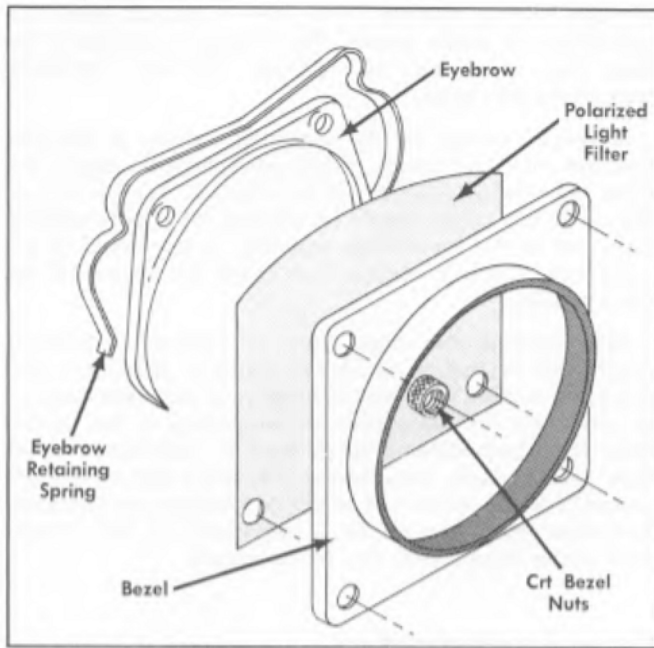

Fig. 4-2. Crt bezel and eyebrow arrangement.



Fig. 4-3. Loosening the crt base clamp.

4. Using a Phillips screwdriver, loosen the crt base clamp (see Fig. 4-3).
5. With your left hand, wiggle the crt socket to ensure that the base of the crt is loose in the base clamp.
6. With a chisel-tipped plastic or wooden dowel, carefully work the crt socket loose from the crt base.

7. Grasp the face of the crt with the right hand. Push the crt carefully towards the front of the Type 544 with the left hand. Be careful not to bend the neck pins. Remove the crt through the front of the oscilloscope.
8. Before reinstalling the crt, dust talcum powder on the crt base. This keeps the base of the crt from sticking to the neoprene bushing inside the base clamp.
9. Carefully insert the new tube into the shield and the tube base clamp. Keep the anode button in line with the anode connector hole so that the button is aligned with the hole when the crt is fully inserted.

**NOTE**

Make sure that the crt base clamp is loose enough to permit the crt base to slide through the neoprene bushing inside the base clamp.

10. Connect the tube socket to the tube base. Check that the socket is fully seated.
11. Align the crt so that the horizontal graticule lines are parallel with the top of the front panel. Push the crt inward until the crt face protrudes exactly  $\frac{3}{16}$ " beyond the front panel.

**NOTE**

If the crt face is not parallel with the front of the oscilloscope, use a  $\frac{7}{64}$ " hexagonal wrench to loosen the two mounting screws that fasten the base clamp to its mounting bracket (see Fig. 4-3). The base clamp and crt base may now be moved radially to align the face of the crt parallel with the front of the oscilloscope.

12. Reconnect the anode and neck pin leads (observe color code).
13. Tighten the base clamp.
14. Turn on the oscilloscope. Obtain a free-running sweep on the crt.
15. Check the alignment of the trace with the graticule lines. If the trace is not parallel with the graticule lines, align the traces with the TRACE ROTATION control.
16. Replace eyebrow, eyebrow retaining spring, plastic polarized light filter, crt bezel and bezel nuts.

**Graticule Lamps**

Proper illumination of the crt graticule depends upon the proper positioning of the graticule lamps. When replacing graticule lamps, slide the lamp and socket in or out until the filament of the lamp is at the middle of the eyebrow thickness.

**Ceramic Terminal Strips**

To remove a ceramic terminal strip, first unsolder all leads and components connected to it. Use diagonal cutters to cut

## Maintenance—Type 544/RM544

off one side of each stud holding the strip. This frees the strip, and the remainder of the stud can then be pulled free of the chassis with a pair of pliers. The spacers may come out with the studs; if not, they can be pulled out separately. If they are not damaged, the spacers may be used with the new strip assembly. Ceramic strips are supplied with studs attached, so it is not necessary to salvage old studs.

After removing a damaged strip and stud assembly, place the spacers into the holes in the chassis and insert the studs into the spacers. If necessary, use a soft-faced mallet to tap the studs into the spacers. Tap the studs in equal increments to prevent strains on the ceramic strip.

## Troubleshooting Techniques

If the instrument is not operating, first check that the power cord is plugged in and that there is power at the socket. Then check that the pilot lamp and tube heaters are lit. If necessary, check the line fuse.

Attempt to isolate the trouble by a quick operational and visual check. Make sure that any apparent trouble is actually due to a malfunction within the instrument and not to improper control settings or to a faulty plug-in unit or probe. Instructions for the operation of the Type 544 and general information concerning plug-in operation are contained in Section 2. Operating instructions for a specific plug-in unit or probe will be found in the manual for that unit.

Check the settings of all controls on the Type 544 and the vertical plug-in preamplifier unit. A control set to the wrong position may cause what appears to be a trouble symptom. Operate the controls to see what effect, if any, they have on the trouble symptom. The normal or abnormal operation of each particular control helps in establishing the nature of the trouble.

When vertical-system troubles are encountered, isolate the trouble to the Type 544 or to the vertical plug-in preamplifier unit. The best way to determine this is by substituting another vertical plug-in preamplifier unit. If the trouble appears to be in the plug-in unit, refer to the Maintenance section of the plug-in unit instruction manual.

If other plug-in units are not available, and the symptoms are not definite, check the power-supply resistances and voltages since a failure in one of the regulated power supplies frequently presents unusual symptoms. Table 5-2 in the Calibration Procedure lists normal resistances to ground for each power-supply lead. Typical voltages in the power supplies are shown on the power-supply schematic. The voltages shown may vary slightly from instrument to instrument.

All wiring in the Type 544 is color coded to facilitate circuit tracing. In addition, all regulated power-supply leads are coded with specific color combinations for easy identification. In general, three stripes are placed on the wires of the regulated supplies. The first color (widest stripe) indicates the first number of the voltage on that lead. The second color indicates the second number of the lead voltage, and the third color is a multiplier. The method is similar to that used

in color coding resistors. Thus, the +100-volt leads are coded brown, black, brown. The voltage is positive if the body color of the wire is white and negative if the body color of the wire is tan.

Reference voltage for the regulated supplies is obtained from the —150-volt supply. If it is not operated properly, the other low-voltage supplies will be affected. For this reason, the —150-volt supply should be checked first when trouble is suspected in the low-voltage supplies. If the output of the —150-volt supply is correct, then check the outputs of the other supplies.

Most troubles that might occur in Tektronix instruments result from the failure of vacuum tubes or semiconductors. Once the trouble has been isolated to a particular area or circuit, check the tubes and semiconductors in the trouble area. It is preferable to check them by substitution rather than with a tester, since testers frequently fail to indicate certain troubles which can affect oscilloscope performance. Remember that when a tube or semiconductor fails, associated circuit components can be damaged.

## Circuit Troubleshooting

The Type 544 consists of six main circuits plus the Calibrator. The six main circuits are the:

1. Low-Voltage Power Supply
2. Crt Circuit (including the High-Voltage Power Supply)
3. Vertical Amplifier and Delay Line
4. Sweep-Trigger Circuit
5. Sweep Generator
6. Horizontal Amplifier

The crt display can often be used to identify a defective circuit. For example, if there is no vertical deflection when the intensity and horizontal deflection appear normal, the trouble can be open signal connections, no signal source, the plug-in unit or even loose crt connections. Other abnormal characteristics in the crt display similarly point to a defective circuit or group of circuits.

Once the nature and approximate location of the trouble has been determined, further isolate the trouble by performing the steps in the calibration procedure for the circuits in which trouble is suspected. The voltages and waveforms to be expected in each circuit are shown on the schematics. Refer to Section 3 for an explanation of the operation of the defective circuit.

### IMPORTANT

When it is desired to operate the plug-in unit from a plug-in extension, the plug-in sensing switch (SW673, located at the top rear of the plug-in compartment) must be manually operated. To manually operate the switch, pull the plastic plunger outward to the stop position.



# SECTION 5

## CALIBRATION

### Introduction

The Type 544 Oscilloscope is a stable instrument which will provide many hours of trouble-free operation. However, to insure measurement accuracy, it is suggested that you recalibrate the instrument after each 500 hours of operation or every six months if used intermittently. It will also be necessary to recalibrate certain sections of the instrument when tubes, transistors, or other components are replaced.

The steps in the following procedure are arranged in the proper order for complete recalibration so as to avoid unnecessary repetition.

### NOTE

This procedure is a combination performance check and adjustment procedure. The first part of the step title is the name of the check or adjustment and the latter portion refers to the pertinent circuit diagram. Tables 5-4, 5-5, 5-9, and 5-10 list the front-panel control settings at particular points in the procedure. These tables serve two purposes: (1) To quickly check your own setup, and (2) to enable you to start in the "middle" of the procedure when it is necessary to recalibrate a certain portion of the instrument. For example, Table 5-4 shows the front-panel setup at the completion of step 12. Using these same control settings this can be the starting point for recalibrating the Sweep Trigger circuit. Thus, the table eliminates the need to go back any further towards the beginning of the procedure to find out what the front-panel setup should be.

Unless otherwise stated, all resistances, voltages, and waveforms are measured with respect to chassis ground.

### EQUIPMENT REQUIRED

The following equipment, or its equivalent, is necessary for complete calibration of the Type 544 Oscilloscope:

- (1) Low-Bandwidth Test Oscilloscope with a 1X attenuator probe.  
Description: Bandwidth, dc to 300 kc or better; calibrated vertical deflection factor of 5 mv/cm.  
Purpose: To check low-voltage power supply output ripple amplitude.
- (2) Test load unit, Tektronix Type TU-7. Contains a pulse generator capable of producing pulses with a risetime of 3 nsec or faster. This multi-purpose test-load unit is the only plug-in needed to perform a complete calibration of the Type 544 Oscilloscope.
- (3) Time Mark generator, Tektronix Type 180A. Markers required at 1 and 5 seconds; 500, 100, 10, 5, and 1 milliseconds; 500, 100, 50, 10, 5, and 1 microseconds; 5, 10, and 50 megacycle sine waves. 10  $\mu$ sec trigger pulse output required. All outputs must have a time accuracy of at least 0.1%.

- (4) VOM (Volt-Ohm-Milliammeter) DC sensitivity of at least 20,000 ohms per volt.  
Calibrated for an accuracy of at least 1% at  $-150$ ,  $+100$ ,  $+225$ , and  $+350$  volts; at least 5% at  $-1850$  volts.
- (5) Variable autotransformer (e.g. Powerstat or Variac). Required specifications: a rating of at least 590 volt-amperes; output voltage range covering the operating range of the oscilloscope under test.
- (6) An rms-calibrated ac voltmeter. Required specifications: a range of 0-150 volts (0-300 volts if the oscilloscope is wired for 230-volt nominal line-voltage operation).
- (7) Two coaxial cables, 50-ohm nominal impedance, 42" long, with BNC plug-connectors on each end. Part No. 012-057.
- (8) Power cord adapter for connecting the 3-wire oscilloscope power cord to a 2-wire receptacle. Part No. 103-013.
- (9) Adapter, single binding post fitted with a BNC plug. Part No. 103-033.
- (10) Coaxial connector adapter with BNC-jack and UHF-plug connector fittings. Part No. 103-015.
- (11) Jumper clip lead, about 4" long. Equipped with miniature alligator clips on each end.
- (12) Two interconnecting leads, 18" long, red, with combination plug-and-jack banana type connectors on each end. Type PC-18R. Part No. 012-031.
- (13) BNC T connector. Fits one BNC jack and accepts two BNC plugs. Part No. 103-032.
- (14) Miscellaneous Items
  - 1—Screwdriver,  $\frac{3}{16}$ " wide bit, shank about 3" long.
  - 1—Screwdriver,  $\frac{3}{32}$ " wide bit, shank about 2" long.
  - 1—Jaco No. 125 insulated low-capacitance-type screw driver with a  $1\frac{1}{2}$ " long shank and  $\frac{1}{8}$ " wide metal tip. Total length is 5". Part No. 003-000.
  - 1—Low-capacitance alignment tool, consisting of a handle (Part No. 003-307), a gray nylon insert with a metal screwdriver tip (Part No. 003-334), and  $\frac{5}{64}$ " hexagonal wrench insert (Part No. 003-310).
  - 1—Hexagonal wrench,  $\frac{1}{16}$ ". Purpose: To reposition, if necessary, the TRIGGERING LEVEL control knob.

### PRELIMINARY PROCEDURE

1. Remove the side and bottom panels from the oscilloscope.
2. Insert the Type TU-7 (item 2) in the oscilloscope vertical plug-in compartment.
3. Set the Type TU-7 Test Function switch to the Low Load position.

## Calibration—Type 544/RM544

4. Lay the oscilloscope on its left side for access to the bottom of the instrument, (and later in the procedure for access to the —150 VOLTS control).
5. Using the VOM, check the resistance at the regulated bus of each power-supply lead to ground at the test points shown in Fig. 5-1. The values of resistance should be approximately as indicated in Table 5-1, once the capacitors are charged by the VOM internal battery.

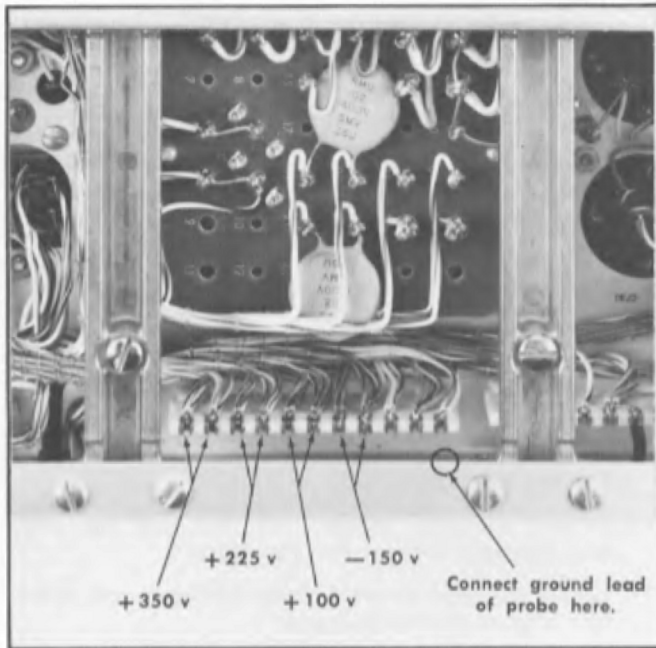

Fig. 5-1. Low-voltage power-supply test point locations (bottom of instrument near the power transformer).

TABLE 5-1

Power Supply Lead	Resistance to Ground
—150 volts	1 k to 2 k
+100 volts	1 k to 2 k
+225 volts	3 k to 4 k
+350 volts	Over 40 k

6. Check the fuse at the rear of the instrument for correct value.
7. Connect the instrument and ac voltmeter to the autotransformer output. Connect the autotransformer to the power line.
8. Turn the INTENSITY control on the instrument fully counterclockwise and turn on the power to all the equipment. Adjust the autotransformer output voltage to 115 volts (or the design-center voltage for which the instrument is wired).
9. Set the oscilloscope front-panel controls to the positions listed in Table 5-2.

TABLE 5-2

INTENSITY	0
FOCUS	As is

ASTIGMATISM	As is
SCALE ILLUM	5
TRIGGERING LEVEL	ccw, knob pushed in
TRIGGERING—	
MODE	TRIG
SLOPE	+
COUPLING	AC
SOURCE	NORM INT
VARIABLE (TIME/CM)	CALIBRATED
TIME/CM	.5 mSEC
HORIZONTAL DISPLAY	NORMAL
Single Sweep Switch	NORMAL
HORIZONTAL POSITION	Midrange
VERNIER (HORIZONTAL POSITION)	Midrange
AMPLITUDE CALIBRATOR	OFF

10. Set the Type TU-7 front-panel controls to these settings:
 

Vertical Position	Centered
Test Function	Low Load
Other Controls	As is
11. Allow about five minutes warm-up time. Check that the EXTERNAL CRT CATHODE-to-GND shorting strap is in place on the terminals and the CRT CATHODE SELECTOR switch is at EXTERNAL CRT CATHODE position.
12. Recheck the autotransformer output for proper design center voltage as soon as the instrument is warmed up.

## CALIBRATION PROCEDURE

### 1. Check Voltage Accuracy—Power Supply

(If necessary, adjust —150 VOLTS R616)

- a. Establish the conditions given in the Preliminary Procedure.
- b. Check that the oscilloscope is placed on its left side for access to the bottom and right side of the instrument.
- c. Check the voltage accuracy of each power supply output using the VOM (item 4) according to the information given in Table 5-3. The location of the test points is shown in Fig. 5-1.

TABLE 5-3

Power Supply	Tolerance	Maximum Peak-to-Peak Ripple
—150 v	—147 to —153 v	10 mv
+100 v	+98 to +102 v	15 mv
+225 v	+220.5 to +229.5 v	10 mv
+350 v	+343 to +357 v	25 mv

- d. If necessary, adjust the —150 VOLTS R616 control [see Fig. 5-2] so all power supply voltages are within tolerance.

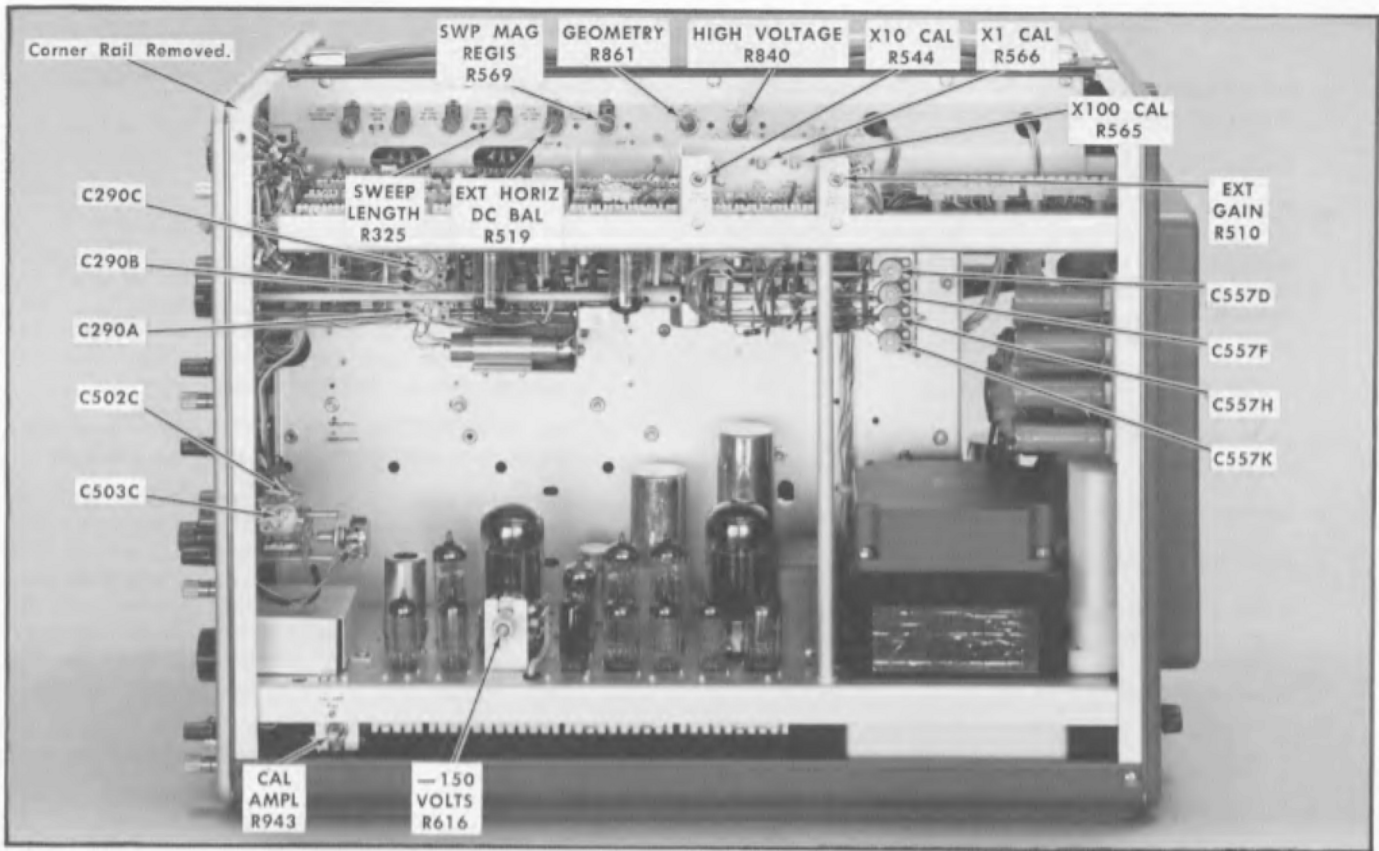

Fig. 5-2. Calibration adjustment locations (right side view).

## NOTE

Don't adjust the —150 VOLTS control unless one or more of the supplies is actually out of tolerance. Remember that the calibration of the entire instrument is affected by changes in the power supply voltages. All the positive voltage power supplies depend upon the —150-volt supply measurement accuracy.

## 2. Check Regulation and Output Ripple—Power Supply

## NOTE

When checking for proper regulation of the power supplies at the lower line voltage limit, the ac line voltage should contain no more than 3% sine-wave distortion.

- a. Monitor the regulated output of the —150-volt supply with the VOM. The test point location is shown in Fig. 5-1.
- b. Connect a 1X probe from a test oscilloscope (item 1) to the —150-volt test point and check the output ripple amplitude. The maximum ripple voltage is given in Table 5-3.

## NOTE

Ground loops can cause an erroneous ripple measurement. (Ripple due to ground loops is the same frequency as the line; low-voltage power supply ripple is twice the line rate.) One way to avoid ripple due to ground loops is to temporarily disconnect the chassis ground wire in the power cord by using an ungrounded 3-to-2 wire line-plug adapter. Then use a ground lead from the signal probe to make a ground connection to the oscilloscope chassis at the location shown in Fig. 5-1. The probe will then provide the only ground connection between the two instruments. The "test oscilloscope" is item 1 while the term "oscilloscope" or "instrument" refers to the oscilloscope being calibrated.

- c. Slowly increase the output of the variable autotransformer to 126.5 vac (or 10% above the design-center line voltage for which the instrument is wired). The dc output voltage should remain essentially constant; typically within 2% of that obtained with design-center line voltage. The ripple voltage should not exceed the maximum peak-to-peak amplitude given in Table 5-3.
- d. Repeat steps 2a through 2c for each supply.

## Calibration—Type 544/RM544

- e. Reset the autotransformer for 115 volts output (or design-center voltage for which the instrument is wired).
- f. Set the Type TU-7 Test Function switch to High Load.
- g. Reduce the line voltage to 103.5 volts (or 10% below design-center voltage). The dc output voltage of each supply should remain essentially constant; typically within 2% of that obtained at design-center voltage. Ripple voltage should not exceed the maximum peak-to-peak amplitude given in Table 5-3.
- h. Disconnect the VOM and X1 probe.
- i. Reset the autotransformer for 115 volts output (or design-center).
- j. Set the Type TU-7 Test Function switch to Low Load.
- k. Place the instrument in its upright position.
- l. If the 3-to-2 line-plug adapter was used during this step, turn off the oscilloscope power and remove the adapter. Plug the line cord directly into the autotransformer and turn on the oscilloscope power.

### 3. Adjust HIGH VOLTAGE R840—Crt Circuit

- a. Set the scale of the VOM to measure  $-1850$  volts and connect the VOM between the high-voltage test point (see Fig. 5-3) and ground.
- b. Adjust the HIGH VOLTAGE control R840 (see Fig. 5-2) for a  $-1850$  voltmeter indication.

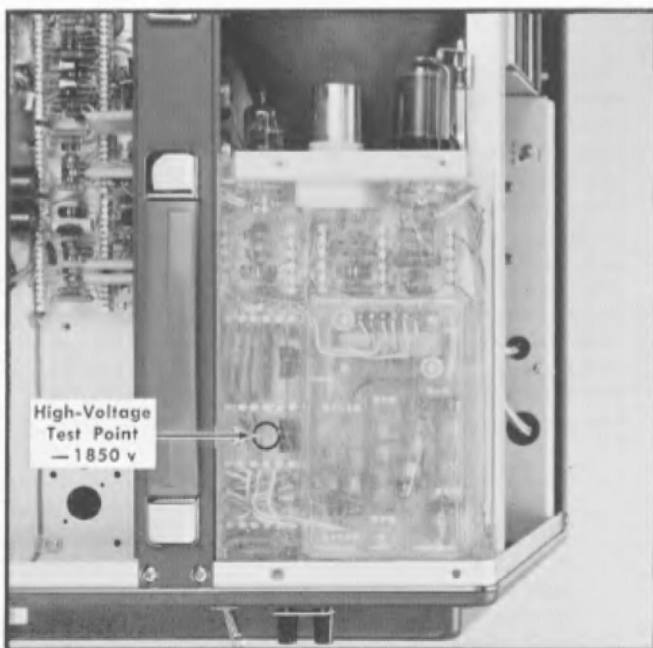

Fig. 5-3. High-voltage test point location (top left rear view).

### 4. Check High Voltage Regulation—Crt Circuit

- a. With the VOM connected to the high voltage test point, use the meter to monitor the voltage at this point.
- b. Set the TRIGGERING MODE switch to AUTO.
- c. Rotate the INTENSITY control clockwise until the trace is at normal intensity. Use the Type TU-7 Vertical Position control to vertically center the trace. Defocus the trace with the FOCUS and ASTIGMATISM controls. Set the INTENSITY control at 7.
- d. Use the HORIZONTAL POSITION control to position the trace to start at the left side of the graticule.
- e. Slowly increase the output of the variable autotransformer to 126.5 vac (or 10% above the design-center line-voltage for which the instrument is wired). The high voltage dc output should remain essentially constant; typically within 2% of that obtained with design-center line voltage. The trace should not show any signs of blooming. (Blooming is when the display changes size as the supply voltage changes.)
- f. Reset the autotransformer for 115 volts output (or design-center voltage for which the instrument is wired).
- g. Set the Type TU-7 Test Function switch to High Load.
- h. Reduce the line voltage to 103.5 volts (or 10% below design-center voltage). The high voltage dc output should remain constant; typically within 2% of that obtained with design-center line voltage. The trace should not show any signs of blooming.
- i. Reset the autotransformer for 115 volts output (or design-center).
- j. Set the Type TU-7 Test Function switch to Low Load.
- k. Decrease the trace intensity to normal with the INTENSITY control.
- l. Disconnect the VOM.

### 5. Adjust CAL AMPL (Calibrator Amplitude) R943—Calibrator

- a. Connect a single binding post adapter (item 9) to the oscilloscope CAL OUT connector.
- b. Connect a VOM to the binding post adapter and to the oscilloscope chassis.
- c. Set the AMPLITUDE CALIBRATOR switch to 100 V DC.
- d. Adjust the CAL AMPL control R943 (see Fig. 5-2) for a voltmeter reading of exactly 100 volts.

### 6. Check Duty Factor of Signal—Calibrator

- a. Set the AMPLITUDE CALIBRATOR switch to 100 VOLTS (not 100 V DC).
- b. Check for a voltmeter reading of  $+45$  to  $+55$  volts as measured between the CAL OUT connector and ground.

**NOTE**

+50 volts indicates a nominal duty factor of 0.5. If the voltage is not within +45 to +55 volts, try new tubes.

- c. Disconnect the VOM and set the AMPLITUDE CALIBRATOR switch to OFF.
- d. Remove the adapter from the CAL OUT connector.

**7. Adjust TRACE ROTATION—Crt Circuit**

- a. Adjust the FOCUS and ASTIGMATISM controls for narrowest trace.
- b. Position the trace directly behind the center horizontal graticule line, using the Type TU-7 Vertical Position control.
- c. If the trace and graticule line do not coincide over the width of the graticule, adjust the TRACE ROTATION control for correct trace alignment.

**8. Adjust GEOMETRY R861—Crt Circuit**

- a. Apply 50  $\mu$ sec markers from the time-mark generator through a coaxial cable to the Type TU-7 Ext Input connector.
- b. Set the TIME/CM switch to 50  $\mu$ SEC.
- c. Advance the INTENSITY control to make the display visible.
- d. Set the TRIGGERING LEVEL control to obtain a stable display of vertical marker lines.
- e. Adjust the TU-7 Variable control so the markers over-scan the crt; set the Vertical Position control to position the base line of the markers below the display area.
- f. Use the HORIZONTAL POSITION control to position the markers so they align with the graticule markings.
- g. Adjust the GEOMETRY control R861 (see Fig. 5-2) for straightest possible vertical marker-lines running parallel to the 0-cm and 10-cm graticule lines. Note the amount of bowing.
- h. Disconnect the signal from the TU-7 Ext Input connector.
- i. Reduce the trace intensity to normal with the INTENSITY control while positioning the trace onto the crt with the TU-7 Vertical Position control.
- j. Using the TU-7 Vertical Position control, position the trace to the bottom of the graticule. Note the amount of bowing. Then position the trace to the top of the graticule and note the amount of bowing.
- k. Repeat steps 8a through 8j so the trace exhibits minimum bowing in both planes.
- l. After completing the previous steps, disconnect the signal from the TU-7 Ext Input connector. Check that the trace is positioned into the display area and the INTENSITY control is set to a suitable trace brightness level.

**9. Adjust VERT DC BAL (Vertical Amplifier Dc Balance) R1004—Vertical Amplifier**

- a. Using a small screwdriver, short the crt vertical deflection plate pins together (see Fig. 5-4).

**CAUTION**

Do not short the crt deflection plate pins to ground.

- b. Note the position of the trace. This is the electrical center of the crt vertical deflection plates.
- c. Remove the screwdriver from the crt pins.
- d. Short the cases of Q1104 and Q1124 (see Fig. 5-4) together (not to ground) and note the deviation of the trace from electrical center. Deviation should not be more than 0.5 cm maximum. Remove the short.

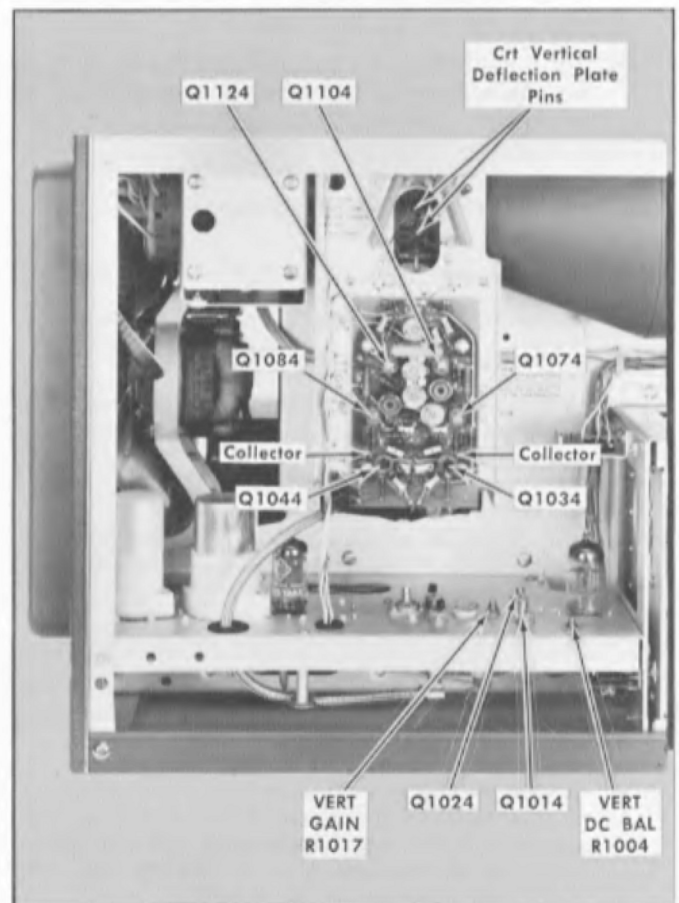

Fig. 5-4. Vertical Amplifier test point and adjustment locations for performing steps 9 and 10.

- e. Short the cases of Q1074 and Q1084 together (see Fig. 5-4) and note the trace deviation from electrical center. Deviation should not be more than 0.5 cm maximum. Remove the short.
- f. Short the collector of Q1034 to the collector of Q1044 (see Fig. 5-4) and note the trace deviation from electrical center. Deviation should not be more than 0.5 cm maximum. Remove the short.

## Calibration—Type 544/RM544

- h. Set the Type TU-7 Test Function switch to Common Mode.
- i. Adjust the VERT DC BAL control R1044 (see Fig. 5-4) to position the trace to the center of the graticule.

### 10. Adjust VERT GAIN (Vertical Amplifier Gain) R1017—Vertical Amplifier

- a. Set the Type TU-7 Test Function switch to the Gain Set position.
- b. Connect a coaxial cable between the Type TU-7 Ext Input connector and the oscilloscope CAL OUT connector.
- c. Set the AMPLITUDE CALIBRATOR switch to 100 VOLTS.
- d. Pull the TRIGGERING LEVEL control outward for X10 range increase and rotate the control fully clockwise to free run the time base.
- e. Adjust the VERT GAIN control R1017 (see Fig. 5-4) so the display vertical deflection is exactly 4 cm in amplitude.

### 11. Check Common-Mode Rejection—Vertical Amplifier

- a. Set the AMPLITUDE CALIBRATOR switch to 1 VOLT.
- b. Set the TU-7 Test Function switch to Common Mode.
- c. Set the TIME/CM switch to .5 mSEC.
- d. Note the amplitude of the calibrator waveform. The amplitude of the waveform should not be more than 3 mm maximum.

### 12. Adjust TRIGGER LEVEL CENTERING R225 and TRIGGER SENS (Trigger Sensitivity) R245—Coarse Adjustment—Sweep Trigger

- a. Set the AMPLITUDE CALIBRATOR switch to OFF.
- b. Insert the BNC T connector (item 13) between the AMPLITUDE CALIBRATOR connector and the coax cable.
- c. Connect another coaxial cable from the 'T' connector to the TRIGGER INPUT connector. (The CAL OUT connector should now be connected to the Ext Input connector on the Type TU-7 and to the TRIGGER INPUT connector on the oscilloscope.)
- d. Set the TU-7 front-panel controls as follows:
 

VARIABLE	Fully cw
POSITION	Centered
TEST FUNCTION	Low Load
- e. Set the MODE switch to TRIG, and the TRIGGERING LEVEL control to 0 (knob pulled out). Check that the COUPLING switch is set to AC and the SOURCE switch is set to NORM. (Table 5-4 lists the remaining front-panel control settings up to this point in the procedure.)

TABLE 5-4

INTENSITY	≈3
FOCUS	≈5
ASTIGMATISM	≈5
SCALE ILLUM	≈8
TRIGGERING LEVEL Knob	Pulled out
TRIGGERING—SLOPE	+
VARIABLE (TIME/CM)	CALIBRATED
TIME/CM	.5 mSEC
HORIZONTAL DISPLAY	NORMAL
Single Sweep Switch	NORMAL
HORIZONTAL POSITION	About $-10^\circ$ from center
VERNIER (HORIZONTAL POSITION)	Midrange

- f. Locate the junction of R217, C218, and R218 (see Fig. 5-5). Connect a short jumper clip lead (item 11) between the junction and ground. This jumper disables the TRIGGERING LEVEL control.

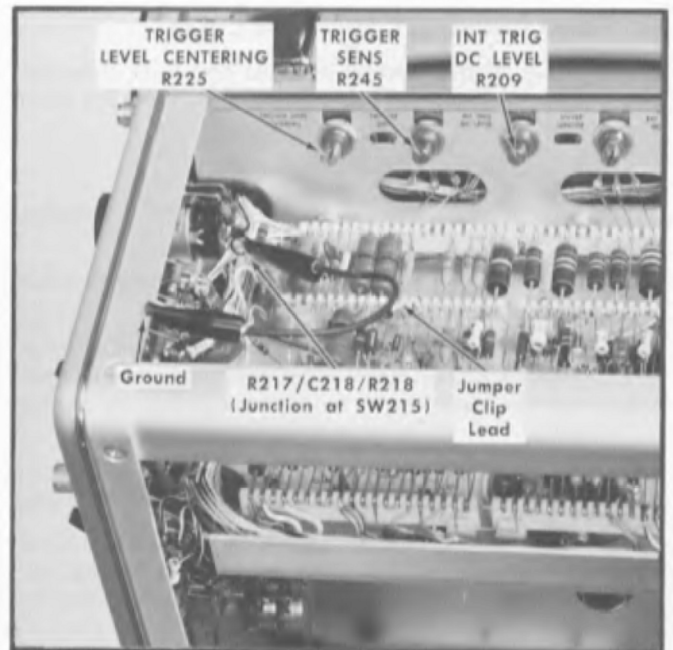

Fig. 5-5. Trigger clip-lead connections, adjustment and test point locations (upper right corner view).

- g. Rotate the TRIGGER LEVEL CENTERING R225 and TRIG SENS R245 controls (see Fig. 5-5) fully clockwise.
- h. Rotate the TRIGGER LEVEL CENTERING R225 control slowly counterclockwise until a steady trace appears. Do not turn the control any further counterclockwise than the point where the steady bright trace was first obtained.

#### NOTE

If a steady trace appears regardless of the setting of the TRIGGER LEVEL CENTERING R225 control, rotate the TRIG SENS R245 control a few degrees

counterclockwise. Return the TRIGGER LEVEL CENTERING R225 control to its fully clockwise position and repeat step (h).

### 13. Adjust TRIGGER LEVEL CENTERING R225 and TRIGGER SENS R245—Fine Adjustment—Sweep Trigger

- a. Set the AMPLITUDE CALIBRATOR switch to 50 mVOLTS.

#### NOTE

A 50-mv peak-to-peak signal is used in this portion of the procedure as an adjustment aid only and is not intended to be interpreted as a trigger-amplitude specification.

- b. Set the SOURCE switch to EXT.
- c. Rotate the TRIGGER SENS R245 control counterclockwise until the displayed waveform disappears. Then rotate the control slightly clockwise until the waveform reappears. Do not turn the control any further clockwise from this point.
- d. Rotate the TRIGGER LEVEL CENTERING R225 control slowly clockwise until the waveform disappears and then rotate the control counterclockwise until the waveform reappears. Continue rotating the control in a counterclockwise direction until the waveform disappears. Note the amount that the TRIGGER LEVEL CENTERING R225 control was moved while obtaining a display.
- e. Set the TRIGGER LEVEL CENTERING R225 control in the center of the range noted in the previous step.
- f. Slowly rotate the TRIGGER SENS R245 control counterclockwise until the displayed waveform disappears. Then turn the control slightly clockwise until a point is reached where the waveform reappears. Do not turn the control any further clockwise from this point.
- g. Repeat steps (d) through (f) to reduce the range of movement of the TRIGGER LEVEL CENTERING R225 control, noted in step (d), as narrow as possible while keeping the waveform displayed. Also the TRIGGER SENS R245 control must be adjusted to a counterclockwise point where, as a final result, a display is barely obtained. That is, the waveform does not necessarily have to be stable; a flickering display can also be an indication of optimum results.

#### NOTE

One fast method for reaching optimum results is to let the waveform disappear as described in the first statement of step (f). Then, use the TRIGGER LEVEL CENTERING R225 control to make the waveform reappear. Alternate between the two controls (R225 and R245) until optimum adjustment of both controls is reached while still displaying a waveform.

### 14. Adjust INT TRIG DC LEVEL (Internal Trigger DC Level) R209—Sweep Trigger

- a. Set the AMPLITUDE CALIBRATOR switch to .5 VOLTS.
- b. Set the SOURCE switch to NORM INT.
- c. Adjust the TU-7 Variable control so the displayed waveform is 5 mm peak-to-peak in amplitude.
- d. Using the TU-7 Vertical Position control, center the display for equal amplitude above and below the center graticule line.
- e. Set the COUPLING switch to DC.
- f. Adjust the INT TRIG DC LEVEL R209 control (see Fig. 5-5) to obtain a stable display. (With the SLOPE switch set to +, the sweep trace should start on the positive-going rise of the calibrator waveform.)

### 15. Check Internal Triggering—Sweep Trigger

- a. Set the COUPLING switch to AC.
- b. Adjust the TU-7 Variable control until the display is 2 mm peak-to-peak in amplitude.
- c. Disconnect the jumper clip lead.
- d. Adjust the TRIGGERING LEVEL control to obtain a stable display.
- e. Operate the SLOPE switch. Check for stable time-base triggering on the —slope when the SLOPE switch is set to — and stable triggering on the + slope when the SLOPE switch is set to +. If necessary, readjust the TRIGGERING LEVEL control to obtain a stable display when making the check for each SLOPE switch position.

### 16. Check TRIGGERING LEVEL Control Zero Set—Sweep Trigger

- a. Check that the TRIGGERING LEVEL control is set to 0 and the SLOPE switch is set to +.
- b. Connect the VOM between the R217/C218/R218 junction and ground.
- c. Carefully rotate the TRIGGERING LEVEL control to obtain a reading of exactly 0 volts on the VOM.
- d. If the TRIGGERING LEVEL knob is set properly on the control shaft, the white dot on the knob should be directly below the 0 on the front panel. If the white dot does not point accurately to 0, disconnect the VOM, loosen the setscrew in the knob, and reposition the knob.
- e. After tightening the knob, set the knob to 0, reconnect the VOM, and recheck the reading. The VOM reading should be zero when the TRIGGERING LEVEL knob is set to 0.

#### NOTE

A dc-coupled test oscilloscope with a 10X probe can be used in place of the VOM to perform this step, if desired. As another method, the white dot on the TRIGGERING LEVEL knob should point to 0 to obtain stable triggering when operating the SLOPE switch as directed in step 15e.

## Calibration—Type 544/RM544

- f. Disconnect the VOM or 10X probe.
- g. Disconnect the coax cables, 'T' connector, and set the AMPLITUDE CALIBRATOR switch to OFF.

### 17. Check MAG ON and UNCALIBRATED Neons—Horizontal Amplifier

- a. Check that the MAG ON neon is lit when the HORIZONTAL DISPLAY switch is set to X2, X5, X10, X20, X50, and X100.
- b. Check that the MAG ON neon is *not* lit when the HORIZONTAL DISPLAY switch is set to EXT and NORMAL.
- c. Check that UNCALIBRATED neon is lit when the combined settings of the TIME/CM switch and HORIZONTAL DISPLAY switch produces a sweep rate 5 nsec/cm or faster. For example: If the TIME/CM switch is set to  $.5 \mu\text{SEC}$  and the HORIZONTAL DISPLAY switch is set to X100, the UNCALIBRATED neon should light.

### 18. Adjust X10 CAL (X10 Magnified Sweep Calibration) R544—Horizontal Amplifier

- a. Set the Time Base front-panel controls to these settings:

TRIGGERING LEVEL	About 25° clockwise from 0
MODE	AUTO
SLOPE	+
COUPLING	AC
SOURCE	NORM INT
TIME/CM	1 mSEC
HORIZONTAL DISPLAY	NORMAL

(All the remaining front-panel control settings up to this point in the procedure are listed in Table 5-5.)

**TABLE 5-5**

#### Oscilloscope

INTENSITY	≈3
FOCUS	≈5
ASTIGMATISM	≈5
SCALE ILLUM	≈8
TRIGGERING LEVEL	Knob pulled outward
VARIABLE (TIME/CM)	CALIBRATED
Single Sweep Switch	NORMAL
HORIZONTAL POSITION	Approximately centered
VERNIER (HORIZONTAL POSITION)	Centered
EXTERNAL HORIZONTAL VOLTS/CM	.1
VARIABLE (EXTERNAL HORIZONTAL VOLTS/CM)	Fully cw
AMPLITUDE CALIBRATOR	OFF

#### Type TU-7

Vertical Position	Centered
Variable	≈3
Test Function	Low Load

- b. Apply 100- $\mu\text{sec}$ , 1-msec and 5-msec time markers from the time-mark generator through a coaxial cable to the TU-7 Ext Input connector.
- c. Set the TU-7 Variable control so the display is about 4 cm in amplitude.
- d. Center the display vertically using the TU-7 Vertical Position control.
- e. Adjust, if necessary, the TRIGGERING LEVEL control to obtain stable triggering on the 5-msec time marks. Fig. 5-6a shows the time markers displayed with respect to the graticule markings. Use the HORIZONTAL POSITION control to position the center 5-msec time marker to the center of the graticule as shown in the illustration.
- f. Set the HORIZONTAL DISPLAY switch to X10. Position the center 5-msec time marker to graticule center (see Fig. 5-6).

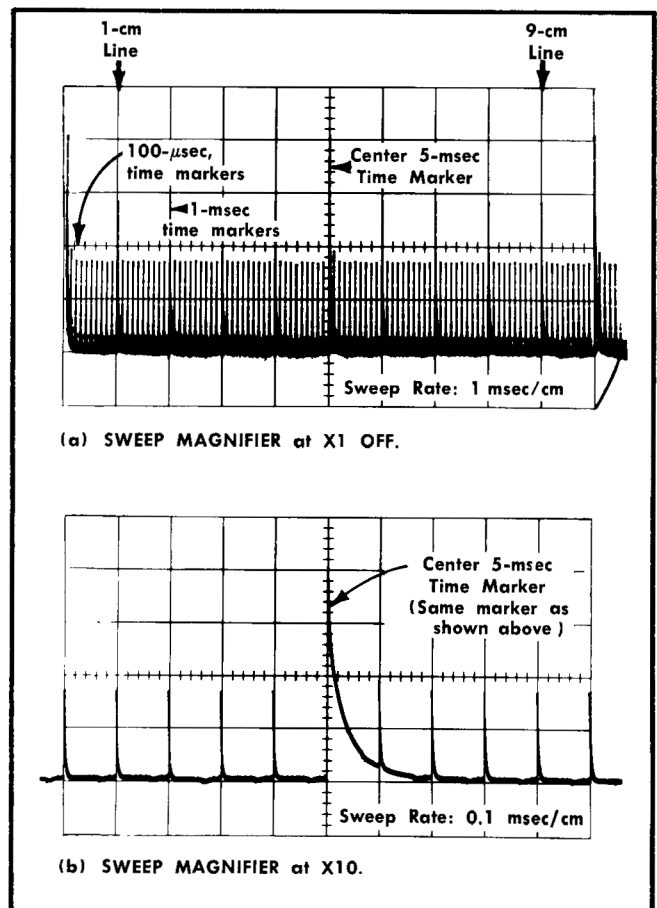

Fig. 5-6. Time marker displays.

- g. Adjust the X10 CAL R544 control (see Fig. 5-2) so there is 1 marker per cm from the 1-cm to 9-cm graticule lines. For accurate adjustment the X10 CAL control should be adjusted so the markers at the 1-cm and 9-cm graticule lines coincide exactly with the 1-cm and 9-cm graticule lines.



NOTE

The following hints should help you to obtain the best results in checking and adjusting the time-base sweep rates:

It is quite difficult to detect small sweep rate errors on the order of 1 or 2% unless measurement is made using most of the graticule width. It is therefore recommended that the sweep rates be checked for correct linearity and timing using the center 8 cm and the middle 80% of the display as shown in Fig. 5-7. With the measurement taken over a distance of 8 cm, the adjustment can be made more accurately. Further on in the procedure when you check the non-adjustable sweep rates, a 1.6 mm error would indicate a 2% sweep-rate error as shown in Fig. 5-7. The marker peak provides an excellent reference point, particularly if the amplitude is such that the base line is below the crt viewing area and the tips of the markers are located in the center of the crt. When using the sine waves for markers at the higher sweep rates, set the TU-7 Variable and Vertical Position controls so the lower half of the display is positioned below the crt and the tips of each cycle are near the center of the crt. By increasing the amplitude of the display in this manner each marker or cycle tip appears much narrower.

The adjustable sweep rates should be set for maximum accuracy. When adjusting the timing capacitors, use a screwdriver having a metal tip and a non-metallic shank to minimize capacitance disturbance to the circuit. This will also lessen the chance of accidentally grounding connections elevated above or below ground.

**21. Check X50, X20, X5 and X2 Sweep-Rate Timing Accuracy**

Using Table 5-6 as a guide, check the X50, X20, X5 and X2 magnified sweep-rate timing. Tolerance is  $\pm 5\%$  or  $\pm 4$  mm for the center 8-cm portion of the display.

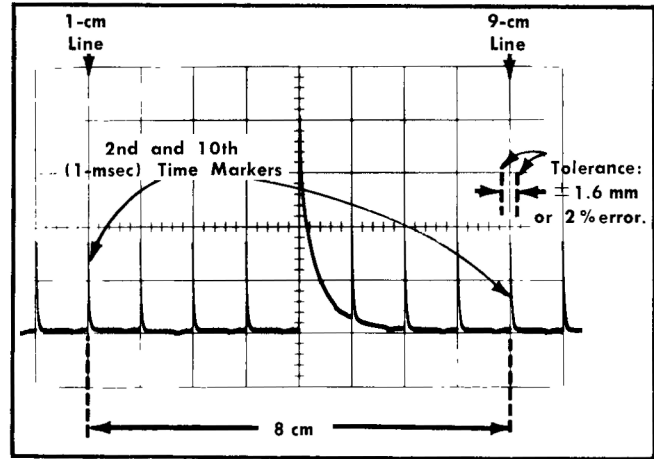

Fig. 5-7. Determining sweep-rate accuracy.

TABLE 5-6

HORIZONTAL DISPLAY Switch Setting	Time-Mark Generator Output	Markers/cm
X50	10 $\mu$ sec	2
X20	50 $\mu$ sec	1
X5	100 $\mu$ sec	2
X2	500 $\mu$ sec	1

**19. Adjust X1 CAL (X1 Sweep Calibration) R566—Horizontal Amplifier**

- Set the HORIZONTAL DISPLAY switch to NORMAL.
- Adjust the X1 CAL R566 control (see Fig. 5-2) so the 1-msec markers are spaced 1-cm apart and so the 1-msec markers at the 1-cm and 9-cm points coincide with the graticule lines.

**20. Adjust X100 CAL (X100 Magnified Sweep Calibration) R565**

- Set the time-mark generator for a 10- $\mu$ sec time-marker output.
- Set the HORIZONTAL DISPLAY switch to X100.
- Adjust the TU-7 Variable control so the markers are about 3 cm in amplitude.
- Adjust the TRIGGERING LEVEL control for stable triggering on the markers.
- Adjust the X100 CAL R565 control (see Fig. 5-2) for one marker per cm.
- Since adjustments R544, R566, and R565 interact, repeat steps 18 through 20 for best timing accuracy.

**22. Adjust SWP/MAG REGIS (Sweep/Magnifier Registration) R569—Horizontal Amplifier**

- Set the time-mark generator for 100- $\mu$ sec and 5-msec time-marker output.
- Set the HORIZONTAL DISPLAY switch to NORMAL.
- Adjust the TU-7 Variable control so the display is about 4-cm in amplitude.
- Adjust the TRIGGERING LEVEL control to obtain a stable display.
- Using the HORIZONTAL POSITION control, position the center 5-msec marker to the graticule center.
- Set the HORIZONTAL DISPLAY switch to X100.
- Repeat step (e). Carefully position the 5-msec marker so the very tip coincides accurately with the center graticule line.
- Set the HORIZONTAL DISPLAY switch to NORMAL.
- Adjust the SWP/MAG REGIS R569 control (see Fig. 5-2) so the center 5-msec marker coincides exactly with the graticule centerline. Repeat steps (e) through (i) until there is minimum movement of the center 5-msec time marker as the HORIZONTAL DISPLAY switch is changed from X100 to NORMAL.

**23. Adjust SWEEP LENGTH R325**

- a. Set the time-mark generator for 100- $\mu$ sec and 1-msec time-marker output.
- b. Check that the HORIZONTAL DISPLAY switch is set to NORMAL.
- c. Adjust the TU-7 Variable control so the display is about 4 cm in amplitude.
- d. If necessary, adjust the TRIGGERING LEVEL control to produce a stable display.
- e. Using the HORIZONTAL POSITION control, position the 11th 1-msec time marker (located at the 10-cm graticule line) to graticule center.
- f. Adjust the SWEEP LENGTH R325 control (see Fig. 5-2) so five 100- $\mu$ sec time markers are displayed after the 11th 1-msec time marker.
- g. Using the HORIZONTAL POSITION control, position the display to start at the left side of the graticule or 0-cm line. If the adjustment is made correctly, the sweep length (or display) should be 10.5 cm long.

**24. Check VARIABLE (TIME/CM) and UNCALIBRATED Neon—Sweep Timing Switch**

- a. Set the time-mark generator for 10-msec time-marker output.
- b. Adjust the TRIGGERING LEVEL control to trigger on the time markers.
- c. Rotate the VARIABLE (TIME/CM) control a few degrees in the counterclockwise direction. The UNCALIBRATED neon should light as the switch on the control is activated.
- d. Rotate the VARIABLE control to its fully counterclockwise position. Note the distance between the markers. The distance should be 4 cm or less.
- e. Set the VARIABLE control to the CALIBRATED position.

**25. Adjust C290C (10- $\mu$ SEC Sweep-Rate Timing)—Sweep Timing Switch**

- a. Set the time-mark generator for 10- $\mu$ sec time-marker output.
- b. Set the TIME/CM switch to 10  $\mu$ SEC.
- c. Set the TU-7 Variable control so the markers are about 4 cm in amplitude.
- d. Adjust the TRIGGERING LEVEL control to trigger on the 10- $\mu$ sec time markers.
- e. Adjust C290C (see Fig. 5-2) so the time markers are spaced 1 cm apart and for correct timing of the markers at the 1-cm and 9-cm graticule lines.

**26. Adjust C290B (1- $\mu$ SEC Sweep Rate Timing)—Sweep Timing Switch**

- a. Set the time-mark generator for 1- $\mu$ sec time-marker output.

- b. Set the TIME/CM switch to 1  $\mu$ SEC.
- c. Set the TU-7 Variable control so the markers are about 4 cm in amplitude.
- d. Adjust C290B (see Fig. 5-2) so the time markers are spaced 1-cm apart and for correct timing of the markers at the 1-cm and 9-cm graticule lines.

**NOTE**

If the first half of the sweep is non-linear and 1-cm spacing of the time markers is difficult to obtain, preadjust C299 (see Fig. 5-8) to improve sweep linearity.

**27. Adjust C290A (.5- $\mu$ SEC Sweep-Rate Timing) Sweep Timing Switch**

- a. Check that the time-mark generator is set for 1- $\mu$ sec marker output.
- b. Connect a coax cable from the trigger out connector on the time-mark generator to the TRIGGER INPUT connector.
- c. Set the trigger rate of the time-mark generator for 10- $\mu$ sec trigger output.
- d. Set the TIME/CM switch to .5  $\mu$ SEC and set the SOURCE switch to EXT.
- e. Push the TRIGGERING LEVEL knob in and adjust the TRIGGERING LEVEL control for stable triggering.
- f. Using the HORIZONTAL POSITION control, position the display so the tip of the 2nd marker coincides with the 1-cm graticule line.
- g. Adjust C290A (see Fig. 5-2) so there is one marker every 2 cm. The 2nd and 6th markers should coincide accurately with the 1-cm and 9-cm graticule lines, respectively.

**28. Adjust C299 (.1- $\mu$ SEC Sweep-Rate Timing) — Sweep Generator**

- a. Set the time-mark generator for 10-mc sine-wave output.
- b. Set the TIME/CM switch to .1  $\mu$ SEC.
- c. If necessary, adjust the TRIGGERING LEVEL controls to obtain a stable display.
- d. Position the 2nd sine wave to align with the 1-cm graticule line.
- e. Adjust C299 (see Fig. 5-8) for proper timing of 1 cycle per cm from the 1-cm to 9-cm graticule lines. (Disregard the first sine wave near the 0-cm graticule line.)
- f. Repeat steps 26 through 28 since adjustment of C299 interacts with C290A and C290B adjustments.

**29. Adjust C572 and C582 (High-Speed Sweep Length Compensation)—Horizontal Amplifier**

- a. Set the time-mark generator for 50-mc sine-wave output.

- b. Check that the TIME/CM switch is set to .1  $\mu$ SEC.
- c. Set the TU-7 Variable control so the display is about 4 cm in amplitude.
- d. Adjust the TRIGGERING LEVEL control to obtain a stable display.
- e. Adjust the HORIZONTAL POSITION control to position the start of the sweep to start at the 0-cm graticule line.
- f. Set the HORIZONTAL DISPLAY switch to X10.
- g. Check that C576 and C586 (see Fig. 5-8) slug-adjusting screws are about six turns above the metal wiper contacts of the capacitors.
- h. Adjust C572 and C582 (see Fig. 5-8) for maximum sweep expansion. (Use a low-capacitance alignment tool when making the adjustments.)

### 30. Adjust C591 (High-Speed Sweep Linearity)—Horizontal Amplifier

Adjust C591 (see Fig. 5-8) for best display linearity of 1 cycle per 2 cm.

### 31. Adjust C576 and C586 (High-Speed Timing Adjustments)—Horizontal Amplifier

Adjust C576 and C586 in equal increments for best timing of 1 cycle per 2 cm from the 2-cm graticule line to the 8-cm graticule line.

#### NOTE

If best timing cannot be obtained and the sweep seems too long, readjust C572 slightly to reduce the displayed gain. If C576 and C586 do not seem to have enough range, repeat steps 29h through 31. If repeating the adjustment procedure causes timing to worsen, C576 and C586 slug-adjusting screws are probably turned in too far. Try presetting the C576 and C586 screws about 7 or 8 turns above the contacts and then repeat steps 29h through 31.

### 32. Adjust C557H (X10 Magnified Sweep Compensation)—Horizontal Amplifier

- a. Rotate the HORIZONTAL POSITION and VERNIER controls clockwise so the start of the sweep (or display) can be seen. Locate the tip of a cycle occurring 40 nsec or more from the start of the sweep. Position the tip of the located cycle so it coincides with the 1-cm graticule line.
- b. Adjust C557H (see Fig. 5-2) for best timing of 1 cycle per 2 cm from the 1-cm to 8-cm graticule lines. If necessary, retouch C591 to obtain best linearity. Repeat the adjustment of C557H and C591 as many times as is necessary for best timing and linearity.
- c. Set the HORIZONTAL DISPLAY switch to NORMAL. Using the HORIZONTAL POSITION control, center the display. Set the HORIZONTAL DISPLAY switch to X10. If the timing needs to be improved, retouch C572 and/or repeat steps 29h through 32c.

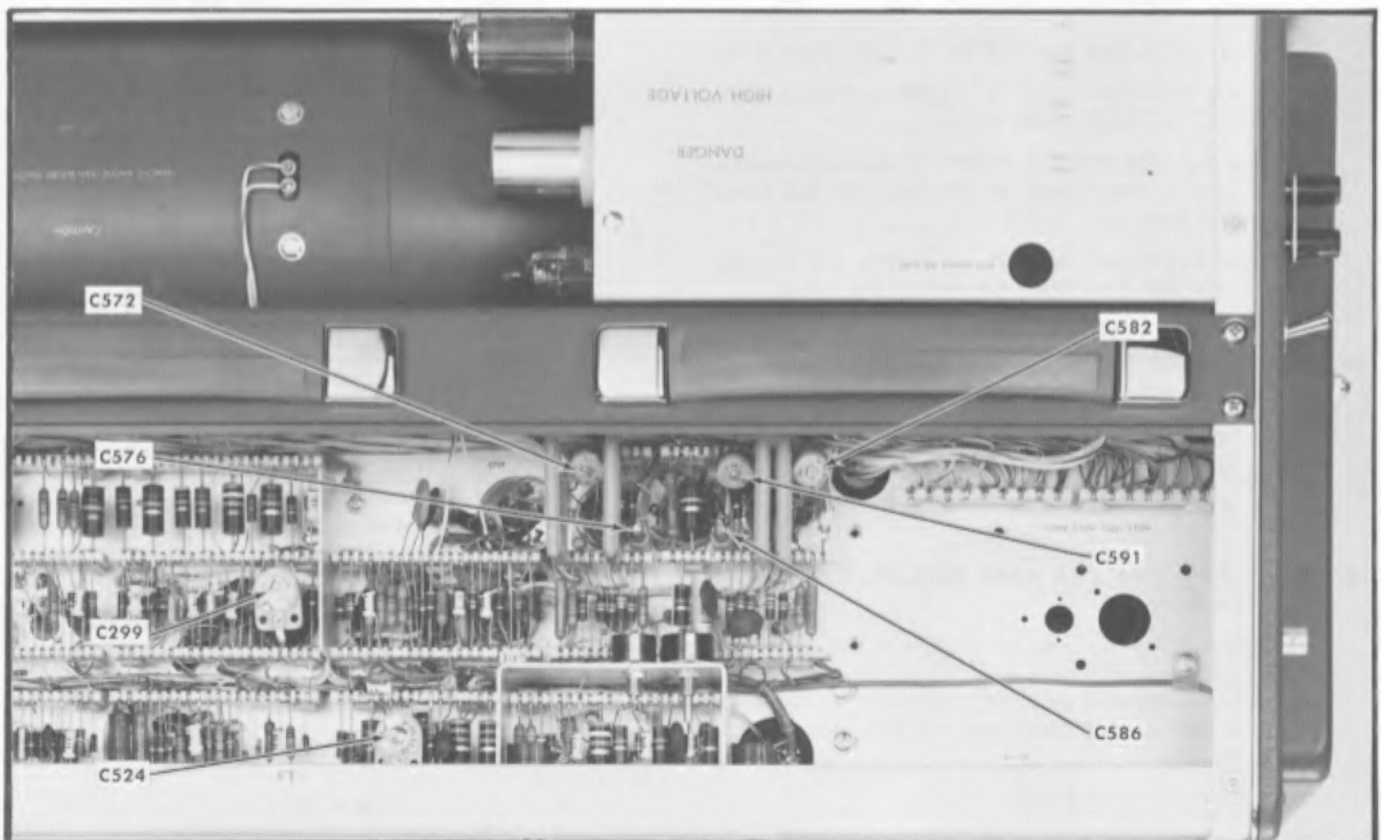

Fig. 5-8. Calibration adjustment locations (top right side view).

- d. Set the HORIZONTAL DISPLAY switch to NORMAL.
- e. Using the HORIZONTAL POSITION and VERNIER controls, position the display so the end of the sweep coincides with the 7-cm graticule line.
- f. Set the HORIZONTAL DISPLAY switch to X10.
- g. Note the timing error of the display from the 1-cm to the 9-cm graticule lines; tolerance should be within  $\pm 5\%$  or  $\pm 4$  mm.
- h. Check the timing accuracy of the display between the 4th cm and 80th cm of the sweep. Magnified-timing in this region must be within  $\pm 5\%$  or less. If, in the 20-cm region some non-linearity is observed, readjust C591 to make the sweep more linear.

NOTE

With some time and care spent in making the adjustments described in steps 29 through 32 as accurately as possible, the X10 magnified sweep timing can be adjusted to  $\pm 5\%$  or better.

**33. Adjust C557K and C557F (X20 and X5 Magnified Sweep Compensations)—Horizontal Amplifier**

- a. Set the TIME/CM switch to  $.2 \mu\text{SEC}$  and the HORIZONTAL DISPLAY switch to NORMAL.
- b. Using the HORIZONTAL POSITION control, position the start of the sweep to coincide with the 4.5-cm point on the graticule.
- c. Set the HORIZONTAL DISPLAY switch to X20.
- d. Adjust C557K (see Fig. 5-2) for 1 cycle every 2 cm.
- e. Set the TIME/CM switch to  $.1 \mu\text{SEC}$  and the HORIZONTAL DISPLAY switch to X5.
- f. Using the HORIZONTAL POSITION control, position the start of the sweep to coincide with the 0-cm graticule line.
- g. Adjust C557F (see Fig. 5-2) for 1 cycle per cm just after the first 2 cm from the start of the sweep.

**34. Adjust C557D (X2 Magnified Sweep Compensation)—Horizontal Amplifier**

- a. Set the SWEEP MAGNIFIER switch to X2.
- b. Adjust C557D (see Fig. 5-2) for  $2\frac{1}{2}$  cycles per cm just after the first cm from the start of the sweep.

**35. Check X20, X50, and X100 Magnified Sweep Compensation**

Using Table 5-7 as a guide, check the X20, X50, and X100 magnified sweep compensations. Check for correct timing within a tolerance of  $\pm 5\%$ , between the 5% point from the start of the sweep and the 80% point of the sweep length.

NOTE

5% point from sweep start can be determined by setting the HORIZONTAL DISPLAY switch to NOR-

MAL and positioning the start of the sweep to coincide with the 4.5-cm point on the graticule. Then set the HORIZONTAL DISPLAY switch to the magnified sweep-rate being checked.

80% point of sweep length can be determined by setting the HORIZONTAL DISPLAY switch to NORMAL and positioning the end of the sweep to coincide with the 7-cm graticule line. Then set the HORIZONTAL DISPLAY switch to the magnified sweep rate being checked.

TABLE 5-7

TIME/CM Switch Setting	HORIZONTAL DISPLAY Switch Setting	Time-Mark Generator Output	Cycle/CM
$.2 \mu\text{SEC}$	X20	50 mc	1 cycle/2 cm
$.5 \mu\text{SEC}$	X50	50 mc	1 cycle/2 cm
$1 \mu\text{SEC}$	X100	50 mc	1 cycle/2 cm

**36. Check  $.1 \text{ mSEC/CM}$  through  $5 \text{ SEC/CM}$  Sweep Rates—Sweep Timing Switch**

- a. Set the time-mark generator for 10-mc sine-wave output.
- b. Set the oscilloscope front-panel controls to these settings:  
TRIGGERING—  
MODE TRIG  
SOURCE NORM INT  
TIME/CM  $.1 \mu\text{SEC}$   
HORIZONTAL DISPLAY NORMAL
- c. Using the oscilloscope HORIZONTAL POSITION and the TU-7 Vertical Position controls, position the display so the sweep-rate timing can be checked.
- d. Starting with the  $.1 \mu\text{SEC/CM}$ , check each of the Time Base sweep rates using Table 5-8 as a guide. Tolerance for the fixed (non-adjustable) sweep rates is  $\pm 2\%$  or  $\pm 1.6$  mm.
- e. After checking the sweep rates, disconnect the time-mark generator and interconnecting cables from the oscilloscope/TU-7 combination.

**37. Adjust EXT HORIZ DC BAL R519—(External) Horizontal Amplifier**

- a. Set the front-panel controls of the oscilloscope and TU-7 to the following settings.

Oscilloscope	
TRIGGERING LEVEL	Fully cw
MODE	AUTO
SOURCE	EXT
TIME/CM	1 mSEC
HORIZONTAL DISPLAY	EXT

Type TU-7

Vertical Position	Centered
Variable	$\approx 3$

The remaining front-panel controls of the oscilloscope and TU-7 are already set to the positions listed in Table 5-9.

**TABLE 5-8**

TIME/CM Switch Setting	Time-Mark Generator Output	Check For
.1 μSEC*	10 mc	1 cycle/cm
.2 μSEC	5 mc	1 cycle/cm
.5 μSEC*	1 μsec	1 marker/2 cm
1 μSEC	1 μsec	1 marker/cm
2 μSEC	1 μsec	2 markers/cm
5 μSEC	5 μsec	1 marker/cm
10 μSEC*	10 μsec	1 marker/cm
20 μSEC	10 μsec	2 markers/cm
50 μSEC	50 μsec	1 marker/cm
.1 mSEC	100 μsec	1 marker/cm
.2 mSEC	100 μsec	2 markers/cm
.5 mSEC	500 μsec	1 marker/cm
1 mSEC*	1 msec	1 marker/cm
2 mSEC	1 msec	2 markers/cm
5 mSEC	5 msec	1 marker/cm
10 mSEC	10 msec	1 marker/cm
20 mSEC	10 msec	2 markers/cm
50 mSEC	50 msec	1 marker/cm
.1 SEC	100 msec	1 marker/cm
.2 SEC	100 msec	2 markers/cm
.5 SEC	500 msec	1 marker/cm
1 SEC	1 sec	1 marker/cm
2 SEC	1 sec	2 markers/cm
5 SEC	5 sec	1 marker/cm

\*Adjusted previously for exact timing.

**TABLE 5-9**

Oscilloscope	
INTENSITY	≈3.5
FOCUS	≈5
ASTIGMATISM	≈5
SCALE ILLUM	≈8
TRIGGERING—	
SLOPE	+
COUPLING	AC
VARIABLE (TIME/CM)	CALIBRATED
Single Sweep Switch	NORMAL
HORIZONTAL POSITION	Centered
VERNIER (HORIZONTAL POSITION)	Centered
EXTERNAL HORIZONTAL VOLTS/CM	.1
VARIABLE (EXTERNAL HORIZONTAL VOLTS/CM)	Fully cw
AMPLITUDE CALIBRATOR	OFF
Type TU-7	
Test Function	Low Load

- b. Connect a single binding post adapter (item 9) to the TU-7 Ext Input connector.
- c. Connect an interconnecting lead (item 12) from the adapter at the TU-7 Ext Input connector to the SWEEP OUT connector on the oscilloscope.
- d. Connect an interconnecting lead (item 12) from the EXTERNAL HORIZ INPUT connector to ground.
- e. Using the HORIZONTAL POSITION control, position the vertical free-running sweep trace to the center of the graticule. Check that the INTENSITY control is set to make the trace visible.
- f. Adjust the EXT HORIZ DC BAL R519 control (see Fig. 5-2) for no horizontal shift of the vertical trace while rotating the VARIABLE (EXTERNAL HORIZONTAL VOLTS/CM) control.
- g. Disconnect the interconnecting lead that connects from the EXTERNAL HORIZ INPUT connector to ground.

**38. Adjust EXT GAIN R510—(External) Horizontal Amplifier**

- a. Connect a BNC T connector to the oscilloscope CAL OUT connector.
- b. Connect a coaxial cable from one end of the BNC T connector to the TRIGGER INPUT connector.
- c. Connect another coaxial cable from the other end of the BNC T connector through a coaxial connector adapter (item 10) to the EXTERNAL HORIZ INPUT connector.
- d. Set the AMPLITUDE CALIBRATOR switch to .5 VOLTS and adjust the TRIGGERING LEVEL control to obtain a stable display.
- e. Check that the VARIABLE (EXTERNAL HORIZONTAL VOLTS/CM) control is set fully clockwise.
- f. Set the HORIZONTAL POSITION control so the display is centered on the crt.
- g. Set the TU-7 Variable control so several cycles of the calibrator waveform are displayed (see Fig. 5-9a).
- h. Adjust EXT GAIN R510 (see Fig. 5-2) so the display is exactly 5 cm in amplitude (see Fig. 5-9a).
- i. Recheck the adjustment of the EXT HORIZ DC BAL R519 control by rotating the VARIABLE (EXTERNAL HORIZONTAL VOLTS/CM) control back and forth and checking that there is no shifting of the left side of the calibrator waveform display. If the left side of the waveform shifts as the VARIABLE control is rotated, readjust EXT HORIZ DC BAL R519 for no trace shift.

**39. Adjust C524 Output Compensation—(External) Horizontal Amplifier**

- a. Check that the VARIABLE (EXTERNAL HORIZONTAL VOLTS/CM) control is rotated to its fully clockwise position.

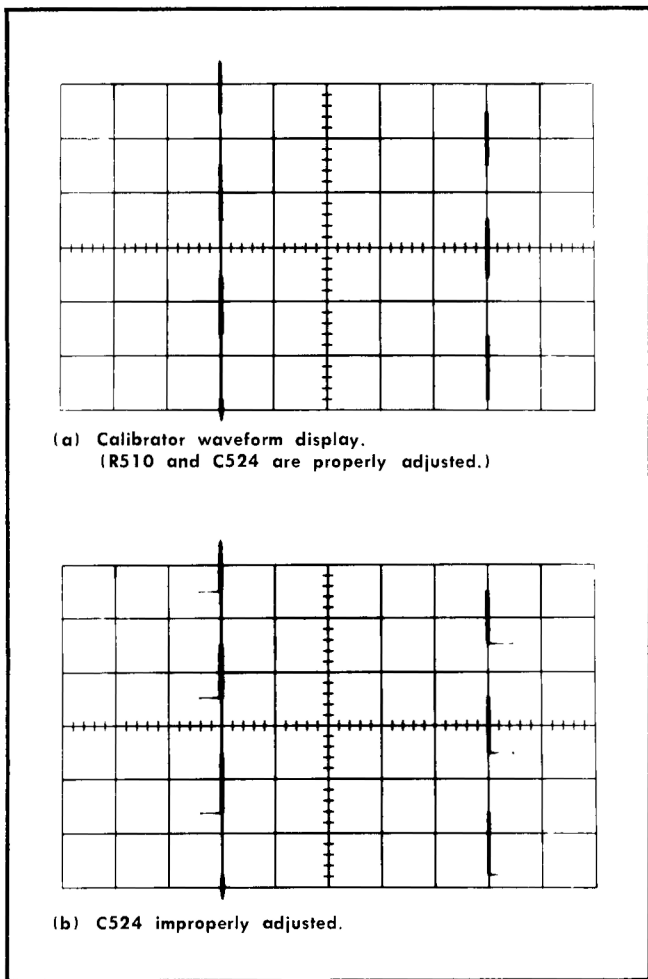

Fig. 5-9. Typical waveform displays obtained when performing steps 39 and 40.

- c. Rotate the VARIABLE (EXTERNAL HORIZONTAL VOLTS/CM) control to its fully clockwise position.
- b. Adjust C524 (see Fig. 5-8) for a least distorted waveform (see Fig. 5-9b); that is, for minimum fast spike or rolloff.

**40. Check VARIABLE Control 10-to-1 Range—(External) Horizontal Amplifier**

- a. Rotate the VARIABLE (EXTERNAL HORIZONTAL VOLTS/CM) control to its fully counterclockwise position.
- b. Check that the waveform is 5 mm or less in amplitude. This is equivalent to 1/10 the amplitude, or less, of the 5-cm display obtained when performing step 38h.

**41. Adjust C503C (X10 Attenuator Compensation)—(External) Horizontal Amplifier**

- a. Set the EXTERNAL HORIZONTAL VOLTS/CM switch to 1 and the AMPLITUDE CALIBRATOR switch to 5 VOLTS.

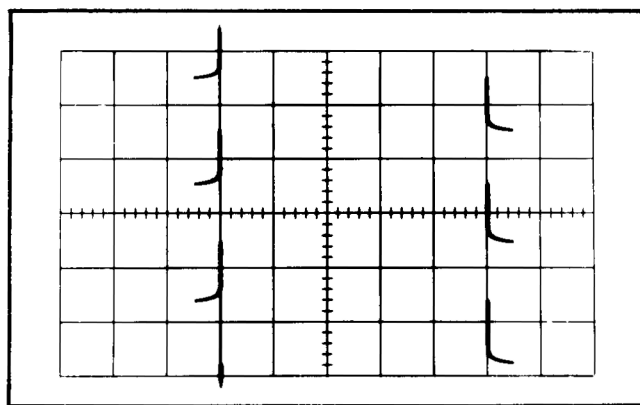

Fig. 5-10. Distortion obtained when C503C is misadjusted.

- b. Check that the display is 5 cm in amplitude. Tolerance is  $\pm 3\%$ .
- c. Adjust C503C (see Fig. 5-2) for optimum square-wave response. The display should exhibit no more than  $\pm 3\%$  hook on the positive-going or negative-going leading corners of the calibrator waveform. When C503C is properly adjusted, the calibrator waveform should appear similar to the display shown in Fig. 5-9a. Fig. 5-10 shows one form of distortion obtained if C503C is misadjusted.

**42. Adjust C502C (X100 Attenuator Compensation)—(External) Horizontal Amplifier**

- a. Set the EXTERNAL HORIZONTAL VOLTS/CM switch to 10 and the AMPLITUDE CALIBRATOR switch to 50 VOLTS.
- b. Check that the display is 5 cm in amplitude. Tolerance is  $\pm 3\%$ .
- c. Using a similar procedure as was done when performing step 41c, adjust C502C for optimum square-wave response. Front corner aberrations should not exceed  $\pm 3\%$ .
- d. Set the AMPLITUDE CALIBRATOR switch to OFF and the HORIZONTAL DISPLAY switch to NORMAL.
- e. Disconnect the adapters, interconnecting lead, and coaxial cables.

**43. Check and/or Adjust High-Frequency Compensations—Vertical Amplifier**

- a. Set the front-panel controls of the oscilloscope to the following positions:
 

TRIGGERING MODE	TRIG
TRIGGERING LEVEL	$-20^\circ$ from 0
SOURCE	NORM INT
TIME/CM	.1 $\mu$ SEC
- b. Set the Type TU-7 front-panel controls as follows:
 

Vertical Position	Centered
Test Function	+ Pulse
Amplitude	$\approx 7.5$

The remaining pertinent front-panel controls up to this point in the procedure are already set to the positions listed in Table 5-10.

TABLE 5-10

Oscilloscope

INTENSITY	≈3.5
FOCUS	≈5
ASTIGMATISM	≈5
SCALE ILLUM	≈8
TRIGGERING LEVEL	Knob pushed in
Single Sweep Switch	NORMAL
HORIZONTAL POSITION	About —45° from center
VERNIER (HORIZONTAL POSITION)	Centered

Type TU-7

Repetition Rate                      Med

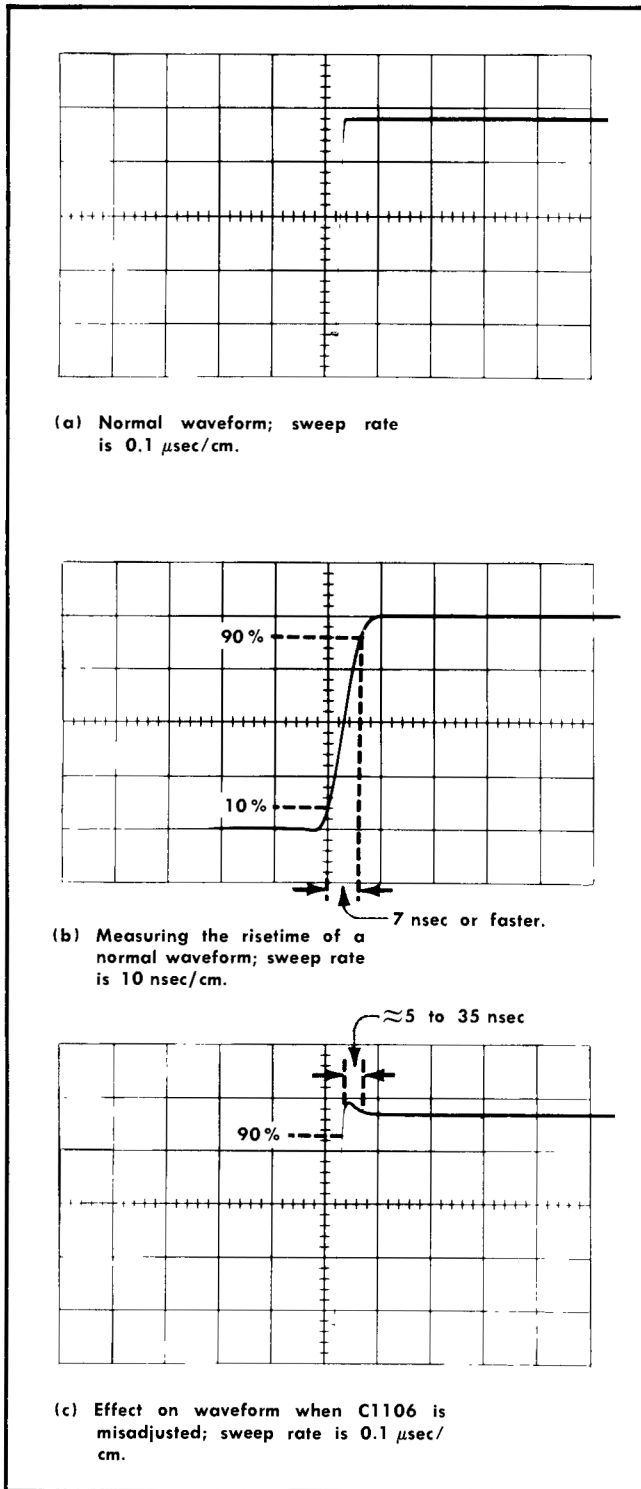

Fig. 5-11. Check of compensation adjustments for optimum Vertical Amplifier transient response.

- c. Using the oscilloscope HORIZONTAL POSITION control, position the display to start near the graticule center.
- d. Set the TU-7 Amplitude and Vertical Position controls so the display is vertically centered on the crt and the amplitude of the step waveform is exactly 4 cm.

- e. Using the TU-7 Vertical Position control, position the waveform downward about 2 cm for easier visibility away from the graticule lines.
- f. Adjust the INTENSITY control to increase the brightness of the display to normal viewing level.
- g. Adjust the FOCUS and ASTIGMATISM controls to produce a well-defined leading top corner on the step waveform.
- h. Examine the waveform for clean transient response. Typical waveform should appear similar to Fig. 5-11a.
- i. Set the HORIZONTAL DISPLAY switch to X10.
- j. Measure the risetime of the rising portion of the waveform from the 10% point to the 90% point (see Fig. 5-11b). The risetime should not be any slower than 7 nsec based on a 3-nsec risetime pulse from the TU-7. (Take into consideration sweep-rate timing error, if any, and/or geometry in the area where the measurement is made.)
- k. If the aberrations appear excessive and/or the risetime is slower than 7 nsec, set the HORIZONTAL DISPLAY switch to X1 and adjust the high-frequency adjustments using Table 5-11 as a guide. Since the adjustments interact, it is necessary to readjust (go back over) the adjustments several times to obtain a waveform with good transient response. When making the adjustments, keep the step waveform vertically centered on the crt.

NOTE

To check the overall level and maintain a flat top when making the adjustments, use the NORMAL and X10 HORIZONTAL DISPLAY switch positions as an aid in checking the waveform appearance.

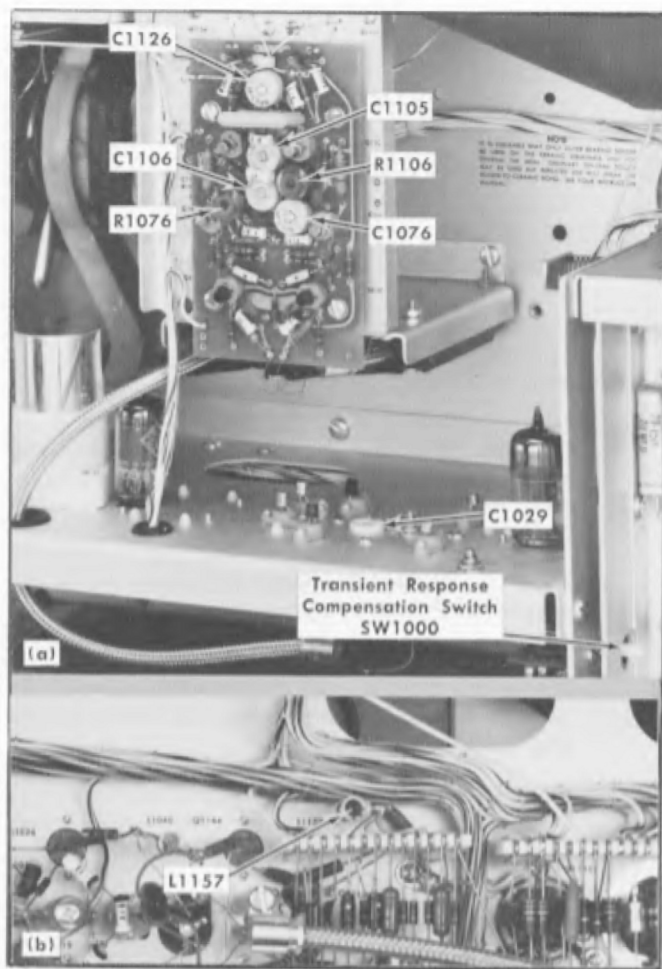

Fig. 5-12. (a) Vertical Amplifier high-frequency adjustments and Transient Response switch locations (center left side view). (b) L1157 location (bottom left side view).

**44. Check Transient Response Compensation Switch SW1000—Vertical Amplifier**

- a. Check that the TIME/CM switch is set to .1  $\mu$ SEC and the HORIZONTAL DISPLAY switch is set to X10.
- b. Depress the Transient Response Compensation SW1000 (see Fig. 5-12a). Check risetime between the 10% and 90% points on the rising portion of the waveform (see Fig. 5-13). Overall risetime should not be any slower than 10 nsec.

**TABLE 5-11**

**Vertical Amplifier High-Frequency Adjustments**

Adjustment	For Location See Fig.	Approximate Area Affected*
L1157	5-12b	0 to 100 nsec, adjust for minimum wrinkles.
C1029**	5-12a	Termination bump at 340 nsec
C1076	5-12a	0 to 15 nsec
C1105	5-12a	1 nsec to 4 nsec
C1106	5-12a	5 nsec to 35 nsec
C1126	5-12a	20 nsec to 80 nsec
R1076	5-12a	0 to 10 nsec
R1106	5-12a	2 nsec to 20 nsec

\*Distance measured to the right starting from the 90% point on the rising portion of the waveform. For an example see Fig. 5-11c.

\*\*If there is no bump or noticeable change in the 340-nsec area when adjusting C1029, the termination is proper. In this case, then, adjust C1029 for a low value of C or for best risetime.

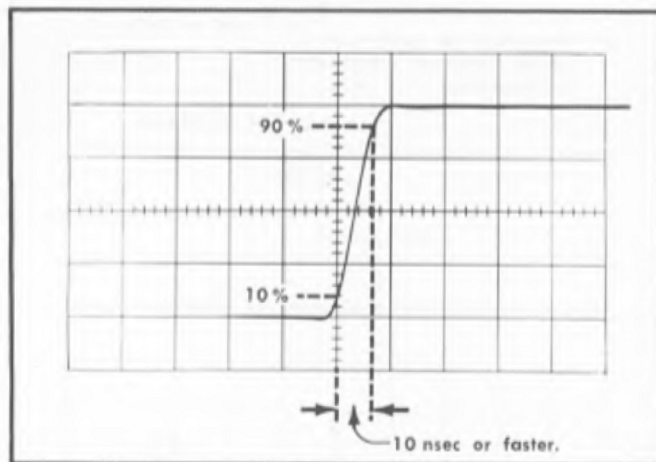

Fig. 5-13. Measuring the risetime of a normal waveform when SW1000 is actuated; sweep rate is 10 nsec/cm.



# SECTION 6

## PARTS LIST and DIAGRAMS

### PARTS ORDERING INFORMATION

Replacement parts are available from or through your local Tektronix Field Office.

Changes to Tektronix instruments are sometimes made to accommodate improved components as they become available, and to give you the benefit of the latest circuit improvements developed in our engineering department. It is therefore important, when ordering parts, to include the following information in your order: Part number including any suffix, instrument type, serial number, and modification number if applicable.

If a part you have ordered has been replaced with a new or improved part, your local Tektronix Field Office will contact you concerning any change in part number.

### ABBREVIATIONS AND SYMBOLS

a or amp	amperes	mm	millimeter
BHS	binding head steel	meg or M	megohms or mega (10 <sup>6</sup> )
C	carbon	met.	metal
cer	ceramic	$\mu$	micro, or 10 <sup>-6</sup>
cm	centimeter	n	nano, or 10 <sup>-9</sup>
comp	composition	$\Omega$	ohm
cps	cycles per second	OD	outside diameter
crt	cathode-ray tube	OHS	oval head steel
CSK	counter sunk	p	pico, or 10 <sup>-12</sup>
dia	diameter	PHS	pan head steel
div	division	piv	peak inverse voltage
EMC	electrolytic, metal cased	plstc	plastic
EMT	electrolytic, metal tubular	PMC	paper, metal cased
ext	external	poly	polystyrene
f	farad	Prec	precision
F & I	focus and intensity	PT	paper tubular
FHS	flat head steel	PTM	paper or plastic, tubular, molded
Fil HS	fillister head steel	RHS	round head steel
g or G	giga, or 10 <sup>9</sup>	rms	root mean square
Ge	germanium	sec	second
GMV	guaranteed minimum value	Si	silicon
h	henry	S/N	serial number
hex	hexagonal	t or T	tera, or 10 <sup>12</sup>
HHS	hex head steel	TD	toroid
HSS	hex socket steel	THS	truss head steel
HV	high voltage	tub.	tubular
ID	inside diameter	v or V	volt
incd	incandescent	Var	variable
int	internal	w	watt
k or K	kilohms or kilo (10 <sup>3</sup> )	w/	with
kc	kilocycle	w/o	without
m	milli, or 10 <sup>-3</sup>	WW	wire-wound
mc	megacycle		

### SPECIAL NOTES AND SYMBOLS

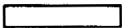
X000	Part first added at this serial number.
000X	Part removed after this serial number.
*000-000	Asterisk preceding Tektronix Part Number indicates manufactured by or for Tektronix, or reworked or checked components.
Use 000-000	Part number indicated is direct replacement.
	Internal screwdriver adjustment.
	Front-panel adjustment or connector.

FRONT

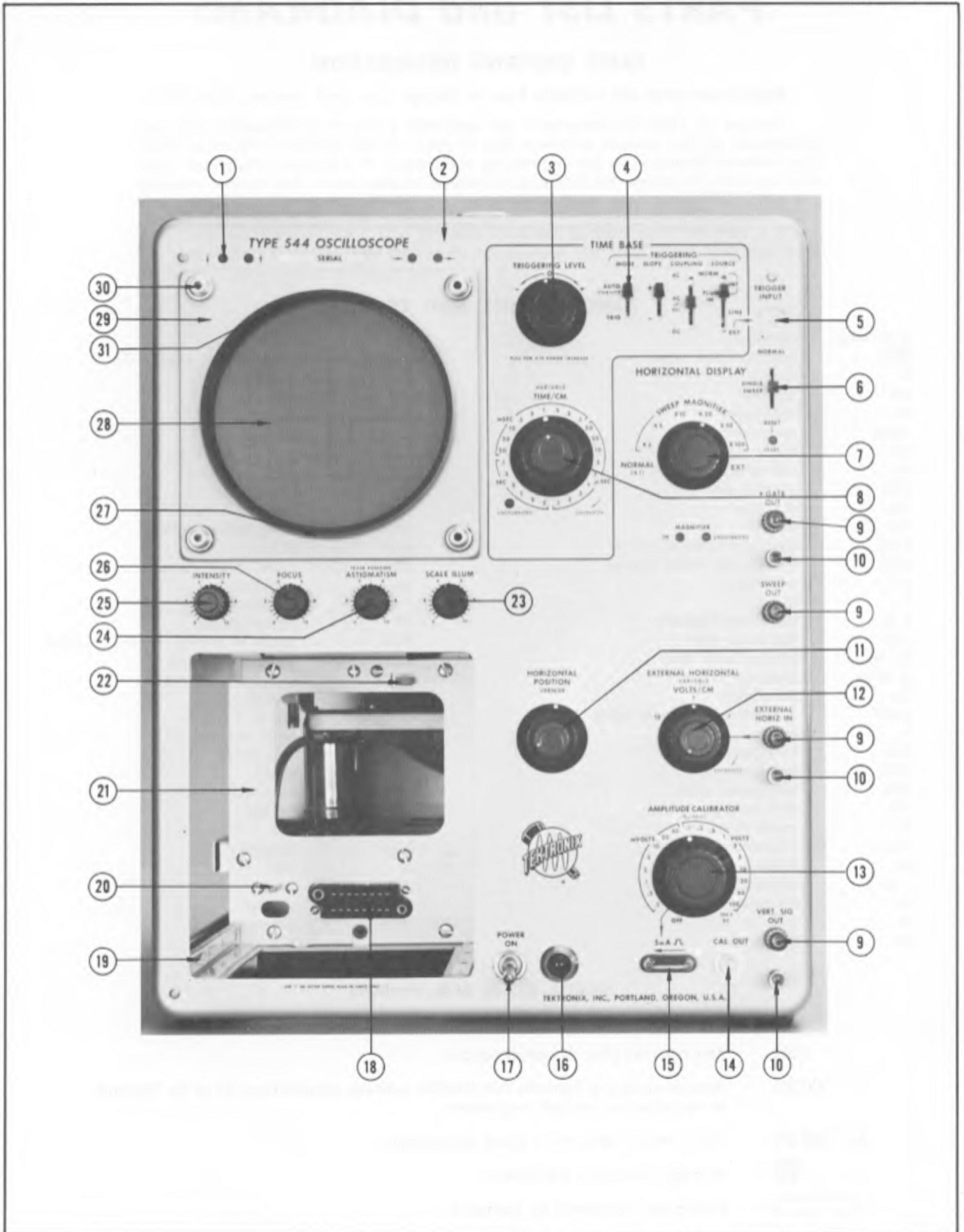

## FRONT

REF. NO.	PART NO.	SERIAL/ MODEL NO.		QTY.	DESCRIPTION
		EFF.	DISC.		
1	378-0541-00			8	FILTER, lens, neon light
2	333-0780-00			1	PANEL, front
	- - - - -			-	Mounting Hardware: (not included)
	213-0088-00			3	SCREW, thread forming, 4-40 x 1/4 inch PHS phillips
	387-0865-00			1	PLATE, front sub-panel
	- - - - -			-	Includes:
	354-0056-00			1	RING, ornamental
3	366-0117-00			1	KNOB, TRIGGERING LEVEL, large charcoal
	- - - - -			-	Includes:
	213-0004-00			1	SCREW, set, 6-32 x 3/16 inch HSS
	- - - - -			-	Mounting Hardware For Pot:
	210-0413-00			1	NUT, hex, 3/8-32 x 1/2 inch
	210-0013-00			1	LOCKWASHER, internal, 3/8 x 1 1/16 inch
4	366-0215-00	100	399	4	KNOB, lever
	366-0215-01	400		4	KNOB, lever
	262-0607-00			1	SWITCH, TRIGGERING, wired
	- - - - -			-	Includes:
	260-0493-00			1	SWITCH, MODE, lever
	260-0494-00			1	SWITCH, COUPLING, lever
	260-0495-00			1	SWITCH, SOURCE, lever
	260-0542-00			1	SWITCH, SLOPE, lever
	213-0141-00			8	SCREW, thread forming, 4-40 x 1/4 inch PHS phillips
	406-0943-00			1	BRACKET, lever switch
	- - - - -			-	Mounting Hardware: (not included)
	210-0586-00			4	NUT, keps, 4-40 x 1/4 inch
	210-0201-00			2	LUG, solder, SE4
5	131-0106-00			1	CONNECTOR, chassis mounted, 1 contact, BNC
	- - - - -			-	Includes:
	210-0413-00			1	NUT, hex, 3/8-32 x 1/2 inch
	210-0012-00			1	LOCKWASHER, internal, 3/8 x 1/2 inch
6	366-0215-00	100	399	1	KNOB, SINGLE SWEEP
	366-0215-01	400		1	KNOB, SINGLE SWEEP
	262-0602-00			1	SWITCH, SWEEP NORMAL, wired
	- - - - -			-	Includes:
	260-0496-00			1	SWITCH, unwired
	260-0516-00			1	SWITCH, RESET, push
	- - - - -			-	Mounting Hardware: (not included)
	211-0034-00			2	SCREW, 2-56 x 1/2 inch RHS
	210-0850-00			2	WASHER, #2 flat
	210-0001-00			2	LOCKWASHER, internal, #2
	210-0405-00			2	NUT, hex, 2-56 x 3/16 inch
	- - - - -			-	Mounting Hardware: (not included)
	210-0586-00			2	NUT, keps, 4-40 x 1/4 inch

FRONT (Cont'd)

REF. NO.	PART NO.	SERIAL/MODEL NO.		QTY.	DESCRIPTION	
		EFF.	DISC.			
7	366-0117-00			1	KNOB, HORIZONTAL DISPLAY, large charcoal	
	- - - - -			-	Includes:	
	213-0004-00			1	SCREW, set, 6-32 x 3/16 inch HSS	
	262-0608-00			1	SWITCH, HORIZONTAL DISPLAY, wired	
	- - - - -			-	Includes:	
	260-0576-00			1	SWITCH, unwired	
	- - - - -			-	Mounting Hardware: (not included)	
	210-0413-00			1	NUT, hex, 3/8-32 x 1/2 inch	
	210-0840-00			1	WASHER, .390 ID x 9/16 inch OD	
	210-0012-00			1	LOCKWASHER, internal, 3/8 x 1/2 inch	
	406-0902-00			1	BRACKET, switch mounting	
	- - - - -			-	Mounting Hardware: (not included)	
	210-0457-00			2	NUT, keps, 6-32 x 5/16 inch	
	406-0897-00			1	BRACKET, trimmer	
	- - - - -			-	Mounting Hardware: (not included)	
	211-0507-00			2	SCREW, 6-32 x 5/16 inch BHS	
	210-0406-00			2	NUT, hex, 4-40 x 3/16 inch	
	210-0004-00			2	LOCKWASHER, internal, #4	
	- - - - -			-	Mounting Hardware For Each Trimmer:	
	213-0088-00			2	SCREW, thread forming, 4-40 x 1/4 inch PHS phillips	
	8	366-0144-00			1	KNOB, TIME/CM, large charcoal
		- - - - -			-	Includes:
		213-0004-00			1	SCREW, set, 6-32 x 3/16 inch HSS
		366-0038-00			1	KNOB, VARIABLE, small red
		- - - - -			-	Includes:
		213-0004-00			1	SCREW, set, 6-32 x 3/16 inch HSS
		262-0606-00			1	SWITCH, TIME/CM, wired
- - - - -				-	Includes:	
260-0530-00				1	SWITCH, unwired	
384-0288-00				1	ROD, extension	
376-0014-00				1	COUPLING, pot	
- - - - -				-	Mounting Hardware For Pot:	
210-0413-00				2	NUT, hex, 3/8-32 x 1/2 inch	
210-0255-00				1	LUG, solder	
210-0012-00				1	LOCKWASHER, internal, 3/8 x 1/2 inch	
406-0909-00				1	BRACKET, TIME/CM switch	
- - - - -				-	Mounting Hardware: (not included)	
210-0449-00				2	NUT, hex, 5-40 x 1/4 inch	
210-0006-00				2	LOCKWASHER, internal #6	
348-0003-00				1	GROMMET, 5/16 inch	
352-0061-00				1	HOLDER, component	
- - - - -				-	Mounting Hardware: (not included)	
211-0008-00				2	SCREW, 4-40 x 1/4 inch BHS	
210-0004-00				2	LOCKWASHER, internal, #4	
210-0406-00				2	NUT, hex, 4-40 x 3/16 inch	
- - - - -				-	Mounting Hardware For Timing Capacitor:	
210-0407-00				4	NUT, hex, 6-32 x 1/4 inch	
210-0006-00			2	LOCKWASHER, internal, #6		
- - - - -			-	Mounting Hardware For Wired Switch: (not included)		
210-0413-00			1	NUT, hex, 3/8-32 x 1/2 inch		
210-0013-00			1	LOCKWASHER, internal, 3/8 x 11/16 inch		
212-0001-00			3	SCREW, 8-32 x 1/4 inch BHS		
210-0804-00			3	WASHER, 8S x 3/8 inch		

## FRONT (Cont'd)

REF. NO.	PART NO.	SERIAL/MODEL NO.		QTY.	DESCRIPTION
		EFF.	DISC.		
9	129-0064-00			4	POST, binding
	-----			-	Mounting Hardware For Each: (not included)
	358-0181-00			1	BUSHING, nylon, charcoal
	210-0457-00			1	NUT, keps, 6-32 x 5/16 inch
10	129-0020-00			3	POST, binding assembly
	-----			-	Each Consisting Of:
	355-0503-00			1	STEM, adapter
	200-0072-00			1	CAP
	-----			-	Mounting Hardware For Each: (not included)
	210-0445-00			1	NUT, hex, 10-32 x 3/8 inch
	210-0010-00			1	LOCKWASHER, internal, #10
11	366-0159-00			1	KNOB, HORIZONTAL POSITION, large charcoal
	-----			-	Includes:
	213-0004-00			1	SCREW, set, 6-32 x 3/16 inch HSS
	366-0032-00			1	KNOB, VERNIER, small red
	-----			-	Includes:
	213-0004-00			1	SCREW, set, 6-32 x 3/16 inch HSS
	-----			-	Mounting Hardware For Pot:
	210-0413-00			1	NUT, hex, 3/8-32 x 1/2 inch
	210-0840-00			1	WASHER, .390 ID x 7/16 inch OD
	210-0012-00			1	LOCKWASHER, internal, 3/8 x 1/2 inch
	210-0207-00			1	LUG, solder, 3/8 inch
12	366-0160-00			1	KNOB, EXTERNAL HORIZONTAL VOLTS/CM
	-----			-	Includes:
	213-0004-00			1	SCREW, set, 6-32 x 3/16 inch HSS
	366-0031-00			1	KNOB, VARIABLE, small red
	-----			-	Includes:
	213-0004-00			1	SCREW, set, 6-32 x 3/16 inch HSS
	262-0609-00			1	SWITCH, EXTERNAL HORIZONTAL VOLTS/CM, wired
	-----			-	Includes:
	260-0207-00			1	SWITCH, unwired
	384-0100-00			1	ROD, extension
	376-0014-00			1	COUPLING, pot
	-----			-	Mounting Hardware For Pot:
	210-0413-00			2	NUT, hex, 3/8-32 x 1/2 inch
	210-0012-00			1	LOCKWASHER, internal, 3/8 x 1/2 inch
	-----			-	Mounting Hardware For Switch: (not included)
	210-0413-00			1	NUT, hex, 3/8-32 x 1/2 inch
	210-0840-00			1	WASHER, .390 ID x 7/16 inch OD
	210-0013-00			1	LOCKWASHER, internal, 3/8 x 11/16 inch
13	366-0115-00			1	KNOB, AMPLITUDE CALIBRATOR, large charcoal
	-----			-	Includes:
	213-0004-00			1	SCREW, set, 6-32 x 3/16 inch HSS
	262-0599-00	100	419	1	SWITCH, AMPLITUDE CALIBRATOR, wired
	262-0731-00	420		1	SWITCH, AMPLITUDE CALIBRATOR, wired
	-----			-	Includes:
	260-0536-00			1	SWITCH, unwired
	-----			-	Mounting Hardware: (not included)
	210-0413-00			1	NUT, hex, 3/8-32 x 1/2 inch
	210-0012-00			1	LOCKWASHER, internal, 3/8 x 1/2 inch

FRONT (Cont'd)

REF. NO.	PART NO.	SERIAL/ MODEL NO.		QTY.	DESCRIPTION
		EFF.	DISC.		
14	131-0274-00			1	CONNECTOR, chassis mounted, BNC
15	214-0335-00			1	BOLT, current loop
	- - - - -			-	Mounting Hardware: (not included)
	210-0593-00			2	NUT, current loop, hex, 5-40 x 1/4 inch
	361-0059-00			1	SPACER, current loop
	210-0849-00			2	WASHER, fiber, #4
	210-0801-00			2	WASHER, 5S x 9/32 inch
	210-0201-00			2	LUG, solder, SE4
	210-0442-00			2	NUT, hex, 3-48 x 3/16 inch
16	378-0518-00			1	JEWEL, pilot light, red
17	260-0199-00			1	SWITCH, POWER ON, toggle
	- - - - -			-	Mounting Hardware: (not included)
	210-0473-00			1	NUT, switch, 15/32-32 x 5/64 inch
	210-0902-00			1	WASHER, .470 ID x 2 1/32 inch OD
	354-0055-00			1	RING, locking, switch
	210-0414-00			1	NUT, hex, 15/32-32 x 9/16 inch
18	131-0018-00			1	CONNECTOR, chassis mounted, 16 contact, female
	- - - - -			-	Mounting Hardware: (not included)
	211-0016-00			2	SCREW, 4-40 x 5/8 inch RHS
	166-0107-00	100	469	2	TUBE, spacing, 7/32 inch
	166-0030-00	470		2	TUBE, spacing, 3/16 inch
	210-0004-00			2	LOCKWASHER, internal, #4
	210-0406-00			2	NUT, hex, 4-40 x 3/16 inch
19	351-0058-00			4	GUIDE, shoe
20	366-0271-00			1	KNOB, COMPENSATION
	260-0601-00			1	SWITCH, COMPENSATION, slide
	- - - - -			-	Mounting Hardware: (not included)
	211-0504-00			2	SCREW, 6-32 x 1/4 inch BHS
21	387-0753-00			1	PLATE, plug-in housing, back
	- - - - -			-	Mounting Hardware: (not included)
	212-0004-00			4	SCREW, 8-32 x 5/16 inch BHS
	212-0023-00			1	SCREW, 8-32 x 3/8 inch BHS
	210-0804-00			3	WASHER, 8S x 3/8 inch
	212-0039-00			1	SCREW, 8-32 x 3/8 inch THS phillips
	210-0458-00			1	NUT, keps, 8-32 x 1 1/32 inch
22	384-0270-00			1	ROD, push switch
	214-0333-00			1	SPRING, push switch rod
23	366-0220-00			1	KNOB, SCALE ILLUM., small charcoal
	- - - - -			-	Includes:
	213-0004-00			1	SCREW, set, 6-32 x 3/16 inch HSS
	- - - - -			-	Mounting Hardware For Pot:
	210-0590-00			1	NUT, hex, 3/8-32 x 7/16 inch
	210-0840-00			1	WASHER, .390 ID x 9/16 inch OD
	210-0013-00			1	LOCKWASHER, internal, 3/8 x 1 1/16 inch

## FRONT (Cont'd)

REF. NO.	PART NO.	SERIAL/ MODEL NO.		QTY.	DESCRIPTION
		EFF.	DISC.		
24	366-0254-00			1	KNOB, ASTIGMATISM, small charcoal
	- - - - -			-	Includes:
	213-0004-00			1	SCREW, set, 6-32 x $\frac{3}{16}$ inch HSS
	- - - - -			-	Mounting Hardware For Pot:
	210-0590-00			1	NUT, hex, $\frac{3}{8}$ -32 x $\frac{7}{16}$ inch
	210-0840-00			1	WASHER, .390 ID x $\frac{7}{16}$ inch OD
	210-0013-00			1	LOCKWASHER, internal, $\frac{3}{8}$ x $\frac{1}{16}$ inch
25	366-0220-00			1	KNOB, INTENSITY, small charcoal
	- - - - -			-	Includes:
	213-0004-00			1	SCREW, set, 6-32 x $\frac{3}{16}$ inch HSS
	- - - - -			-	Mounting Hardware For Pot:
	210-0590-00			1	NUT, hex, $\frac{3}{8}$ -32 x $\frac{7}{16}$ inch
	210-0840-00			1	WASHER, .390 ID x $\frac{7}{16}$ inch OD
	210-0013-00			1	LOCKWASHER, internal, $\frac{3}{8}$ x $\frac{1}{16}$ inch
26	366-0220-00			1	KNOB, FOCUS, small charcoal
	- - - - -			-	Includes:
	213-0004-00			1	SCREW, set, 6-32 x $\frac{3}{16}$ inch HSS
	- - - - -			-	Mounting Hardware For Pot:
	210-0590-00			1	NUT, hex, $\frac{3}{8}$ -32 x $\frac{7}{16}$ inch
	210-0840-00			1	WASHER, .390 ID x $\frac{7}{16}$ inch OD
	210-0013-00			1	LOCKWASHER, internal, $\frac{3}{8}$ x $\frac{1}{16}$ inch
27	354-0204-00			1	RING, crt shockmount
28	378-0545-00			1	FILTER, LIGHT
29	200-0382-00			1	COVER, graticule
	- - - - -			-	Includes:
	354-0116-00			1	RING, ornamental
	- - - - -			-	Mounting Hardware: (not included)
	210-0424-00			4	NUT, knurled, $\frac{3}{8}$ -24 x $\frac{7}{16}$ inch
	210-0816-00			4	WASHER, rubber
30	355-0043-00			4	STUD, graticule, replacement
	- - - - -			-	Each Includes:
	212-0507-00			1	SCREW, 10-32 x $\frac{3}{8}$ inch BHS
	210-0010-00			1	LOCKWASHER, internal, #10
31	387-0917-00	100	319	1	PLATE, light reflector
	386-0212-00	320		1	PLATE, light reflector
	214-0433-00	100	319	1	SPRING, eyebrow hold down
	354-0262-00	320		1	RING, reflector, light plate

TOP

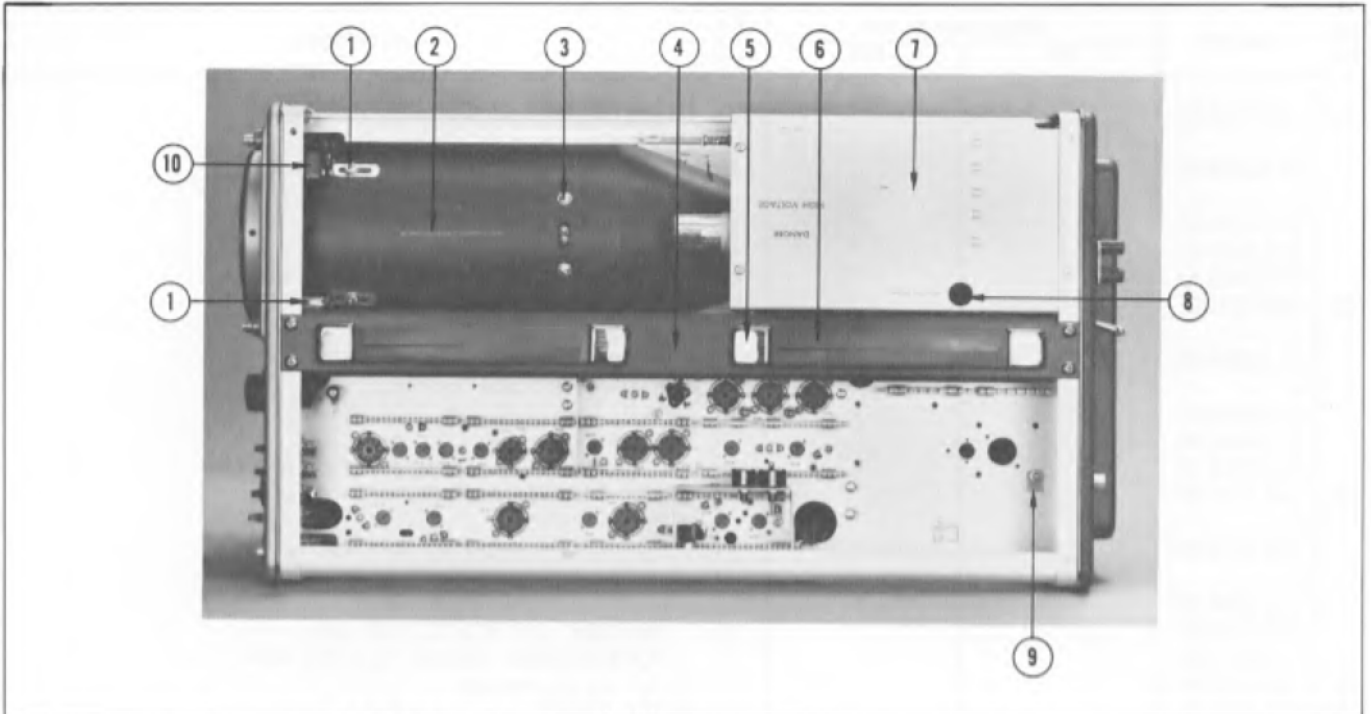

REF. NO.	PART NO.	SERIAL/MODEL NO.		QTY.	DESCRIPTION
		EFF.	DISC.		
1	136-0035-00			2	SOCKET, graticule lamp
	- - - - -			-	Mounting Hardware For Each: (not included)
	211-0534-00			1	SCREW, 6-32 x 5/16 inch PHS with lockwasher
	210-0803-00			1	WASHER, 6L x 3/8 inch
	210-0457-00			1	NUT, keps, 6-32 x 5/16 inch
	166-0328-00	X190		2	SLEEVE, insulating, light socket
2	337-0620-00			1	SHIELD, crt
	- - - - -			-	Mounting Hardware: (not included)
	211-0504-00			4	SCREW, 6-32 x 1/4 inch BHS
3	- - - - -			-	Mounting Hardware For Trace Rotator Coil:
	211-0507-00	100	279	3	SCREW, 6-32 x 5/16 inch BHS
	211-0596-00	280		3	SCREW, 6-32 x 3/8 inch PHB, phillips
	210-0811-00	X280		3	WASHER, fiber, #6
	210-0803-00	X280		3	WASHER, 6L x 3/8 inch
	210-0457-00			3	NUT, keps, 6-32 x 5/16 inch
4	381-0217-00			1	BAR, top support, with handle
	- - - - -			-	Includes:
	344-0098-00			4	CLIP, handle
	212-0566-00			4	SCREW, 10-32 x 5/16 inch RHS, phillips
6	367-0037-00			2	HANDLE
	- - - - -			-	Mounting Hardware: (not included)
	212-0039-00			4	SCREW, 8-32 x 3/8 inch THS phillips
	381-0073-00			2	BAR, retaining
7	337-0566-00			1	SHIELD, high voltage
	- - - - -			-	Mounting Hardware: (not included)
	211-0504-00			4	SCREW, 6-32 x 1/4 inch BHS
	211-0541-00			1	SCREW, 6-32 x 1/4 inch FHS phillips
8	348-0005-00			1	GROMMET, plastic, 1/2 inch
9	343-0070-00			1	CLAMP, cable, 1/8 inch nylon
	- - - - -			-	Mounting Hardware: (not included)
	211-0510-00			1	SCREW, 6-32 x 3/8 inch BHS
	210-0803-00			1	WASHER, 6L x 3/8 inch
	210-0457-00			1	NUT, keps, 6-32 x 5/16 inch
10	200-0534-00			1	COVER, neon holder



RIGHT SIDE

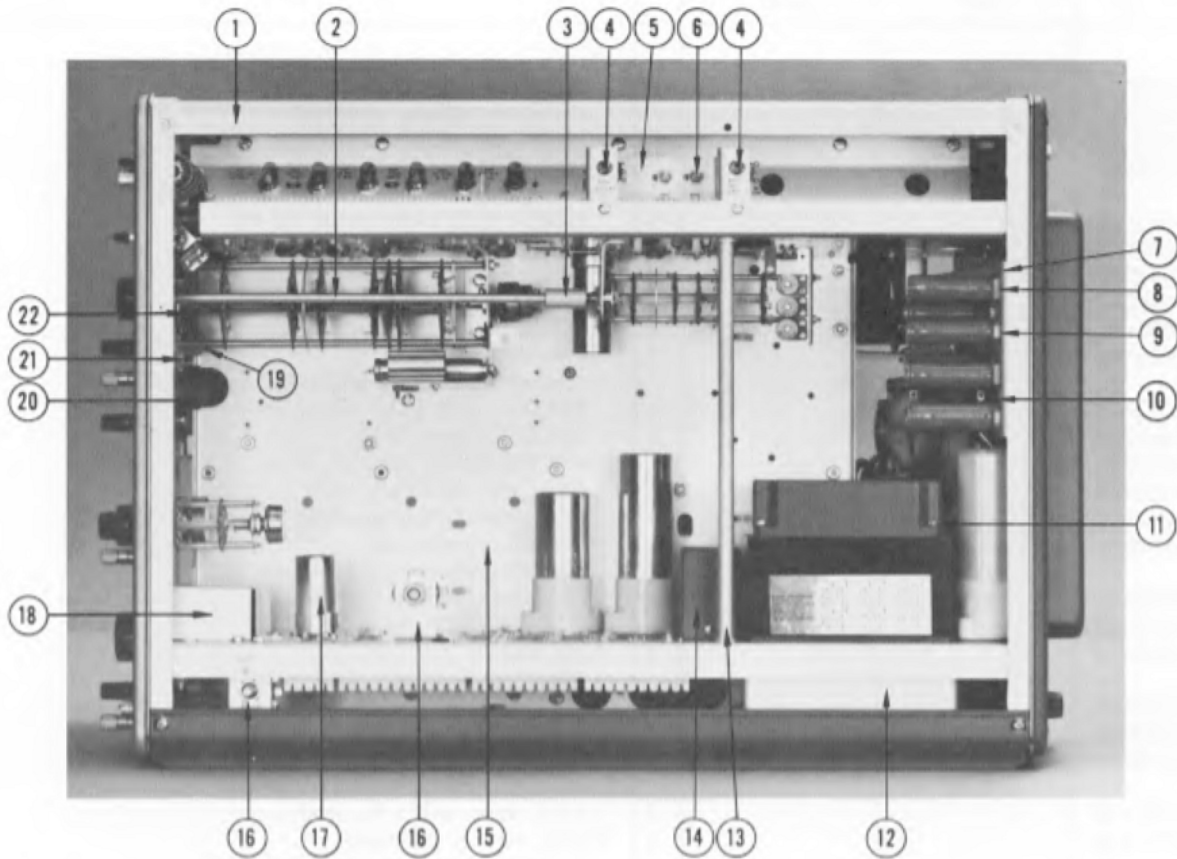

REF. NO.	PART NO.	SERIAL/MODEL NO.		QTY.	DESCRIPTION
		EFF.	DISC.		
1	122-0019-00			1	ANGLE, frame, top right
	- - - - -			-	Mounting Hardware: (not included)
	211-0559-00			4	SCREW, 6-32 x 3/8 inch FHS phillips
	210-0457-00			4	NUT, keps, 6-32 x 5/16 inch
2	384-0029-00			1	ROD, extension
	- - - - -			-	Mounting Hardware: (not included)
	358-0029-00			1	BUSHING, hex, 3/8-32 x 13/32 inch
	210-0413-00			1	NUT, hex, 3/8-32 x 1/2 inch
3	376-0007-00			1	COUPLING
	- - - - -			-	Includes:
	213-0005-00			2	SCREW, set, 8-32 x 1/8 inch HSS
4	- - - - -			-	Mounting Hardware For Each Pot:
	358-0054-00			1	BUSHING, banana jack
	210-0471-00			1	NUT, 1/4-32 x 5/16 x 19/32 inch
	210-0046-00			2	LOCKWASHER, internal, .400 OD x .261 inch ID
5	337-0595-00			1	SHIELD, horizontal preamplifier
	- - - - -			-	Mounting Hardware: (not included)
	211-0504-00			2	SCREW, 6-32 x 1/4 inch BHS
6	- - - - -			-	Mounting Hardware For Each Pot:
	210-0583-00			1	NUT, hex, 1/4-32 x 3/16 inch
	210-0940-00			1	WASHER, 1/4 ID x 3/8 inch OD
7	406-0910-00			1	BRACKET, shunt resistor
	- - - - -			-	Mounting Hardware: (not included)
	211-0537-00			2	SCREW, 6-32 x 3/8 inch THS phillips

RIGHT SIDE (Cont'd)

REF. NO.	PART NO.	SERIAL/MODEL NO.		QTY.	DESCRIPTION
		EFF.	DISC.		
8	- - - - -			-	Mounting Hardware For Each 20 Watt Resistor:
	212-0037-00			1	SCREW, 8-32 x 1 <sup>3</sup> / <sub>4</sub> inches Fil HS
	210-0808-00			1	WASHER, resistor centering
	210-0462-00			1	NUT, hex, resistor mounting
	212-0004-00			1	SCREW, 8-32 x <sup>5</sup> / <sub>16</sub> inch BHS
9	- - - - -			-	Mounting Hardware For Each 25 Watt Resistor:
	212-0037-00			1	SCREW, 8-32 x 1 <sup>3</sup> / <sub>4</sub> inches Fil HS
	210-0008-00			1	LOCKWASHER, internal, #8
	210-0809-00			1	WASHER, resistor centering
	210-0462-00			1	NUT, hex, resistor mounting
	212-0004-00			1	SCREW, 8-32 x <sup>5</sup> / <sub>16</sub> inch BHS
10	348-0004-00			2	GROMMET, <sup>3</sup> / <sub>8</sub> inch
11	- - - - -			-	Mounting Hardware For Transformer:
	212-0524-00			4	SCREW, 10-32 x 3 <sup>1</sup> / <sub>4</sub> inches HHS
	210-0812-00			4	WASHER, fiber, #10
	210-0010-00			4	LOCKWASHER, internal, #10
	210-0564-00			2	NUT, hex, 10-32 x <sup>3</sup> / <sub>8</sub> inch
	384-0612-00			2	ROD, transformer standoff
12	406-0928-00			1	BRACKET, transformer
	- - - - -			-	Mounting Hardware: (not included)
	210-0564-00			2	NUT, hex, 10-32 x <sup>3</sup> / <sub>8</sub> inch
	210-0010-00			2	LOCKWASHER, internal, #10
13	385-0174-00			1	ROD, anchor
	- - - - -			-	Mounting Hardware: (not included)
	358-0238-00			2	BUSHING, anchor rod
	212-0008-00			2	SCREW, 8-32 x <sup>1</sup> / <sub>2</sub> inch BHS
14	202-0102-00			1	CAN, relay cover
	- - - - -			-	Mounting Hardware: (not included)
	210-0457-00			2	NUT, keps, 6-32 x <sup>5</sup> / <sub>16</sub> inch
15	387-0915-00			1	PLATE, vertical bulkhead
	- - - - -			-	Mounting Hardware: (not included)
	212-0040-00			4	SCREW, 8-32 x <sup>3</sup> / <sub>8</sub> inch FHS phillips
	210-0458-00			4	NUT, keps, 8-32 x <sup>11</sup> / <sub>32</sub> inch
	212-0001-00			3	SCREW, 8-32 x <sup>1</sup> / <sub>4</sub> inch BHS
	212-0004-00			2	SCREW, 8-32 x <sup>5</sup> / <sub>16</sub> inch BHS
	210-0804-00			5	WASHER, 8S x <sup>3</sup> / <sub>8</sub> inch
16	406-0023-00			2	BRACKET, pot
	- - - - -			-	Mounting Hardware For Each: (not included)
	211-0507-00			2	SCREW, 6-32 x <sup>5</sup> / <sub>16</sub> inch BHS
	210-0006-00			2	LOCKWASHER, internal, #6
	210-0407-00			2	NUT, hex, 6-32 x <sup>1</sup> / <sub>4</sub> inch
17	337-0008-00			1	SHIELD, tube

RIGHT SIDE (Cont'd)

REF. NO.	PART NO.	SERIAL/MODEL NO.		QTY.	DESCRIPTION
		EFF.	DISC.		
18	337-0574-00			1	SHIELD, calibrator switch
	- - - - -			-	Mounting Hardware: (not included)
	211-0507-00			1	SCREW, 6-32 x 5/16 inch BHS
	210-0803-00			1	WASHER, 6L x 3/8 inch
	210-0457-00			1	NUT, keps, 6-32 x 5/16 inch
19	352-0067-00			2	HOLDER, neon, single
	- - - - -			-	Mounting Hardware For Each: (not included)
	211-0109-00			1	SCREW, 4-40 x 7/8 inch FHS
	210-0406-00			2	NUT, hex, 4-40 x 3/16 inch
20	358-0166-00			1	BUSHING, plastic, black
21	352-0064-00			3	HOLDER, neon, double
	- - - - -			-	Mounting Hardware For Each: (not included)
	211-0109-00			1	SCREW, 4-40 x 7/8 inch FHS
	210-0406-00			2	NUT, hex, 4-40 x 3/16 inch
22	343-0013-00			1	CLAMP, cable, 3/8 inch
	- - - - -			-	Mounting Hardware: (not included)
	210-0457-00			1	NUT, keps, 6-32 x 5/16 inch
	210-0863-00			1	WASHER, "D" type, #10

LEFT SIDE

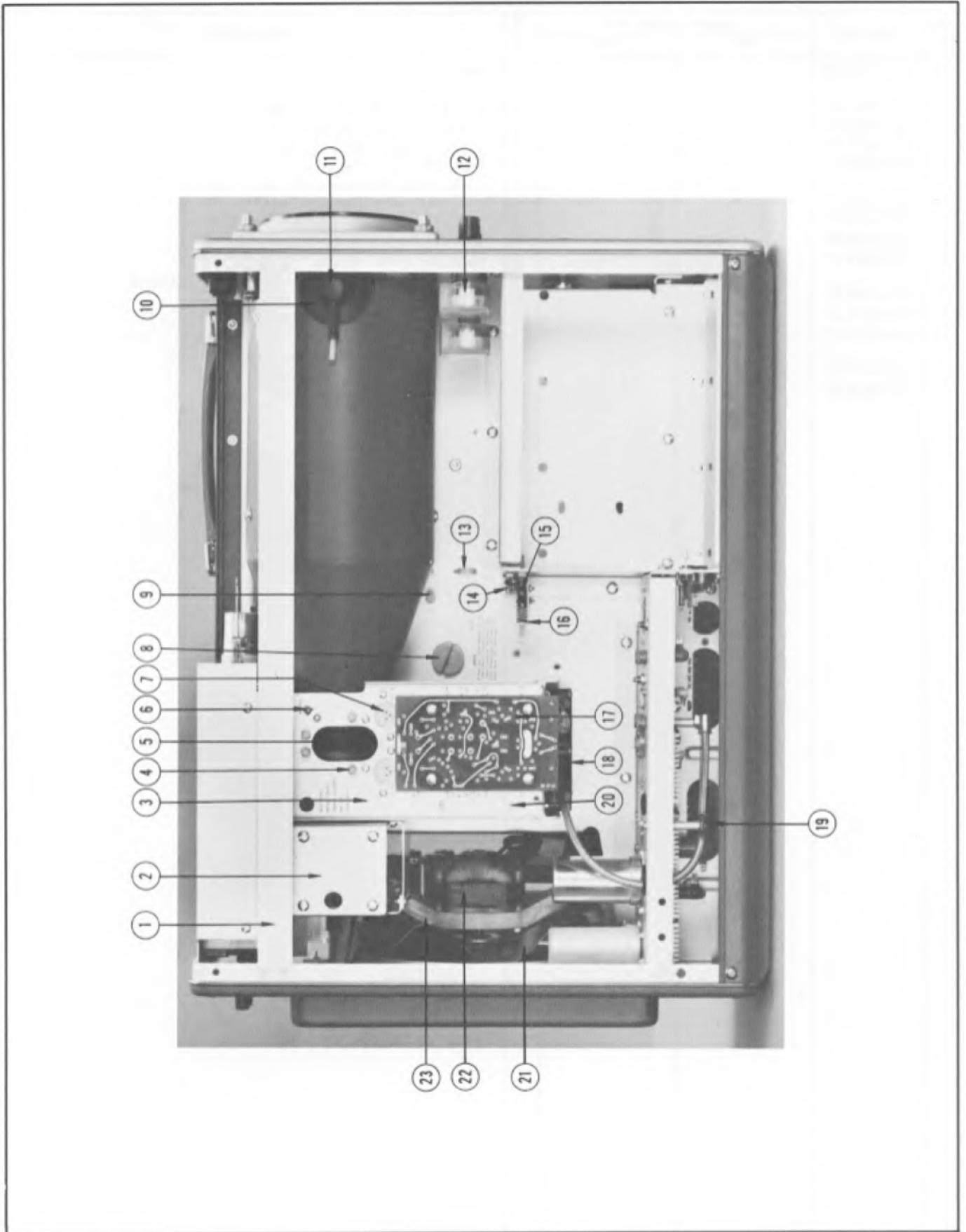

## LEFT SIDE

REF. NO.	PART NO.	SERIAL/ MODEL NO.		QTY.	DESCRIPTION
		EFF.	DISC.		
1	122-0109-00			1	ANGLE, rail, top left
	- - - - -			-	Mounting Hardware: (not included)
	211-0559-00			4	SCREW, 6-32 x $\frac{3}{8}$ inch FHS phillips
	210-0457-00			4	NUT, keps, 6-32 x $\frac{5}{16}$ inch
2	406-0995-00			1	BRACKET, support
	- - - - -			-	Mounting Hardware: (not included)
	212-0001-00			4	SCREW, 8-32 x $\frac{1}{4}$ inch BHS
	210-0458-00			2	NUT, keps, 8-32 x $\frac{1}{32}$ inch
	210-0804-00			2	WASHER, 8S x $\frac{3}{8}$ inch
3	441-0476-00			1	CHASSIS, output vertical amplifier
	- - - - -			-	Mounting Hardware: (not included)
	212-0004-00			2	SCREW, 8-32 x $\frac{5}{16}$ inch BHS
	210-0804-00			2	WASHER, 8S x $\frac{3}{8}$ inch
	210-0458-00			4	NUT, keps, 8-32 x $\frac{1}{32}$ inch
4	129-0069-00			4	POST, capacitor tie
	- - - - -			-	Mounting Hardware For Each: (not included)
	361-0007-00			1	SPACER, nylon, .063 inch
5	131-0335-00			1	CONNECTOR, deflection lead, assembly, brown (not shown)
	131-0336-00			1	CONNECTOR, deflection lead, assembly, blue (not shown)
	175-0588-00			1	WIRE, crt lead, .833 foot, striped orange (not shown)
	175-0592-00			1	WIRE, crt lead, .960 foot, striped green (not shown)
	175-0595-00			1	WIRE, crt lead, .960 foot, striped red (not shown)
6	210-0201-00			2	LUG, solder, SE4
	- - - - -			-	Mounting Hardware For Each: (not included)
	213-0044-00			1	SCREW, thread cutting, 5-32 x $\frac{3}{16}$ inch PHS phillips
7	214-0317-00			2	HEAT SINK, insulator disc
	- - - - -			-	Mounting Hardware For Each: (not included)
	352-0062-00			1	HOLDER, transistor heat sink
	343-0097-00			1	CLAMP, transistor heat sink
	211-0008-00			2	SCREW, 4-40 x $\frac{1}{4}$ inch BHS
	211-0012-00			2	SCREW, 4-40 x $\frac{3}{8}$ inch BHS
	210-0406-00			4	NUT, hex, 4-40 x $\frac{3}{16}$ inch
	210-0599-00			2	NUT, sleeve
	214-0368-00			1	SPRING, transistor heat sink holder
	210-0627-00			1	RIVET
8	214-0210-00			1	SPOOL, solder, assembly
	- - - - -			-	Includes:
	214-0209-00			1	SPOOL, solder
	- - - - -			-	Mounting Hardware: (not included)
	361-0007-00			1	SPACER, nylon, .063 inch
9	385-0134-00			1	ROD, delrin
	- - - - -			-	Mounting Hardware: (not included)
	213-0104-00			1	SCREW, thread forming, 6-32 x $\frac{3}{8}$ inch THS phillips
10	200-0112-00			1	COVER, crt anode and plate assembly
	- - - - -			-	Consisting Of:
	200-0111-00			1	COVER, crt anode
	386-0647-00			1	PLATE, crt anode
11	131-0283-00			1	CONNECTOR, anode assembly
	- - - - -			-	Includes:
	200-0110-00			1	CAP, CRT anode

LEFT SIDE (Cont'd)

REF. NO.	PART NO.	SERIAL/MODEL NO.		QTY.	DESCRIPTION
		EFF.	DISC.		
12	200-0269-00			2	COVER, pot
13	343-0089-00			9	CLAMP, cable, size "D", delrin snap
14	343-0013-00			1	CLAMP, cable, 3/8 inch
	- - - - -			-	Mounting Hardware: (not included)
	210-0458-00			1	NUT, keps, 8-32 x 1 1/32 inch
	210-0863-00			1	WASHER, "D" type, #10
	210-0804-00			1	WASHER, 8S x 3/8 inch
15	260-0516-00			1	SWITCH, push
	- - - - -			-	Mounting Hardware: (not included)
	211-0034-00			2	SCREW, 2-56 x 1/2 inch RHS
	210-0001-00			2	LOCKWASHER, internal, #2
	210-0405-00			2	NUT, hex, 2-56 x 3/16 inch
16	406-0903-00			1	BRACKET, switch mounting
	- - - - -			-	Mounting Hardware: (not included)
	211-0510-00			2	SCREW, 6-32 x 3/8 inch BHS
17	670-0401-00			1	BOARD, printed circuit, upper vertical amplifier (wired)
	- - - - -			-	Includes:
	136-0150-00			6	SOCKET, 3 pin transistor
	343-0088-00			1	CLAMP, cable, size "C", delrin snap
	- - - - -			-	Mounting Hardware: (not included)
	211-0507-00			4	SCREW, 6-32, x 5/16 inch BHS
	210-0801-00			4	WASHER, 5S x 3/32 inch
18	119-0030-00			1	DELAY LINE, assembly
	- - - - -			-	Includes:
	380-0049-00			1	HOUSING, delay line
	200-0482-00			1	COVER, delay line housing
	131-0271-00			2	CONNECTOR, right hand
	211-0011-00			1	SCREW, 4-40 x 3/8 inch BHS
	211-0513-00			1	SCREW, 6-32 x 5/8 inch BHS
	211-0517-00			4	SCREW, 6-32 x 1 inch BHS
	210-0201-00			1	LUG, solder, SE4
	210-0407-00			9	NUT, hex, 6-32 x 1/4 inch
	210-0406-00			1	NUT, hex., 4-40 x 3/16 inch
	- - - - -			-	Mounting Hardware: (not included)
	210-0407-00			4	NUT, hex, 6-32 x 1/4 inch
	210-0006-00			4	LOCKWASHER, internal, #6
19	343-0003-00			1	CLAMP, cable, 1/4 inch
	- - - - -			-	Mounting Hardware (not included)
	211-0507-00			1	SCREW, 6-32 x 5/16 inch BHS
	210-0863-00			1	WASHER, "D" type, #10
	210-0803-00			1	WASHER, 6L x 3/8 inch
20	343-0088-00			2	CLAMP, cable, size "C", delrin snap
21	369-0007-00			1	FAN, 7 inch
22	147-0026-00			1	MOTOR, fan
	- - - - -			-	Mounting Hardware: (not included)
	210-0458-00			4	NUT, keps, 8-32 x 1 1/32 inch
23	426-0193-00			1	MOUNT, fan motor
	- - - - -			-	Mounting Hardware: (not included)
	212-0039-00			4	SCREW, 8-32 x 3/8 inch THS phillips

BOTTOM

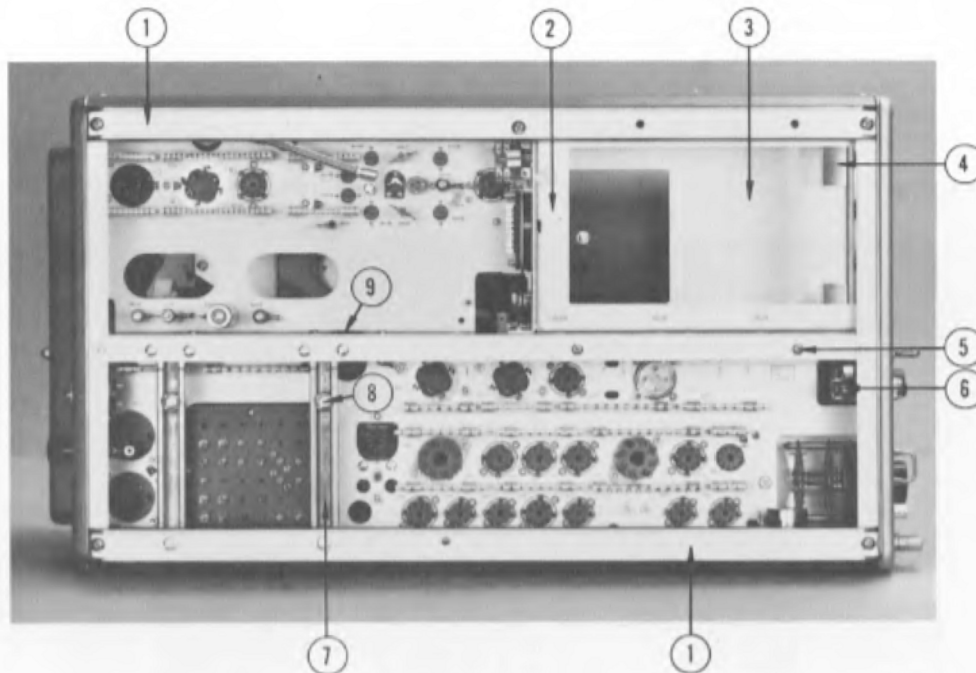

REF. NO.	PART NO.	SERIAL/MODEL NO.		QTY.	DESCRIPTION
		EFF.	DISC.		
1	122-0108-00			2	ANGLE, rail, bottom
	- - - - -			-	Mounting Hardware For Each: (not included)
	212-0039-00			4	SCREW, 8-32 x 3/8 inch THS phillips
	210-0458-00			4	NUT, keps, 8-32 x 11/32 inch
2	387-0755-00			1	PLATE, plug-in housing, bottom
	- - - - -			-	Mounting Hardware: (not included)
	212-0040-00			2	SCREW, 8-32 x 3/8 inch FHS phillips
	212-0004-00			2	SCREW, 8-32 x 5/16 inch BHS
	210-0458-00			4	NUT, keps, 8-32 x 11/32 inch
3	387-0754-00			1	PLATE, plug-in housing, top
	- - - - -			-	Mounting Hardware: (not included)
	212-0040-00			2	SCREW, 8-32 x 3/8 inch FHS phillips
	212-0010-00			1	SCREW, 8-32 x 5/8 inch BHS
	212-0004-00			4	SCREW, 8-32 x 5/16 inch BHS
	210-0804-00			3	WASHER, 8S x 5/8 inch
	210-0458-00			4	NUT, keps, 8-32 x 3/8 inch
4	344-0097-00			2	CLIP, grounding
5	385-0134-00			2	ROD, delrin (not shown)
	- - - - -			-	Mounting Hardware For Each: (not included)
	213-0104-00			1	SCREW, thread forming, 6-32 x 3/8 inch THS phillips
6	136-0026-00			1	SOCKET, light
7	381-0221-00			2	BAR, transformer support
	- - - - -			-	Mounting Hardware For Each: (not included)
	212-0033-00			2	SCREW, 8-32 x 3/4 inch BHS
	210-0458-00			2	NUT, keps, 8-32 x 11/32 inch
	212-0509-00			1	SCREW, 10-32 x 5/8 inch BHS
	212-0534-00			1	SCREW, 10-32 x 1 inch BHS
	210-0010-00			2	LOCKWASHER, internal, #10
8	- - - - -			-	SEE RIGHT SIDE VIEW FOR TRANSFORMER MOUNTING
9	348-0006-00			1	GROMMET, 3/4 inch

REAR

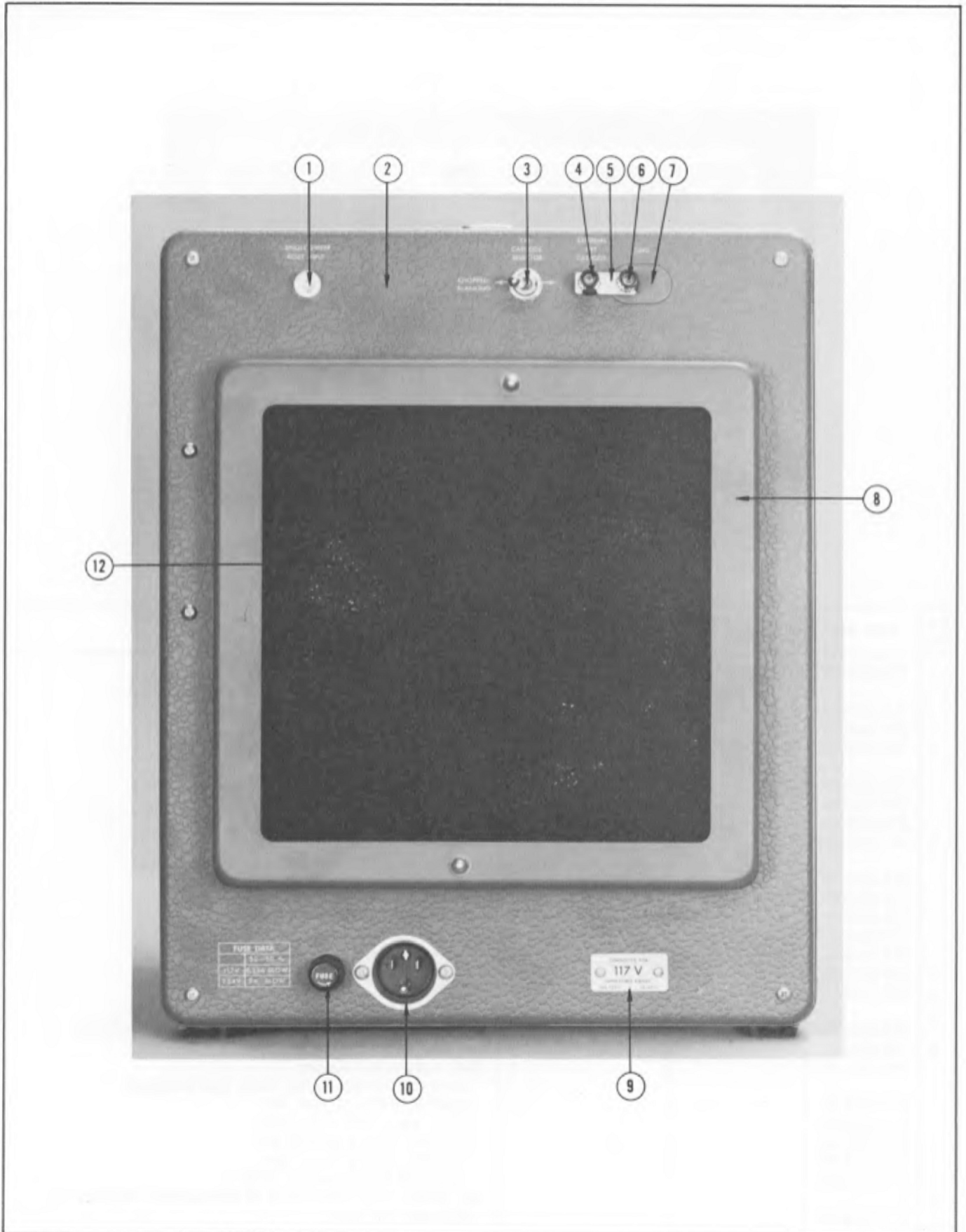



## REAR

REF. NO.	PART NO.	SERIAL/MODEL NO.		QTY.	DESCRIPTION
		EFF.	DISC.		
1	131-0106-00			1	CONNECTOR, chassis mounted, 1 contact, BNC
	- - - - -			-	Mounting Hardware: (not included)
	210-0413-00			1	NUT, hex, $\frac{3}{8}$ -32 x $\frac{1}{2}$ inch
	210-0255-00			1	LUG, solder
2	387-0868-00			1	PLATE, rear overlay
	- - - - -			-	Mounting Hardware: (not included)
	213-0104-00			4	SCREW, thread forming, 6-32 x $\frac{3}{8}$ inch THS phillips
	387-0758-00			1	PLATE, rear sub-panel
	- - - - -			-	Includes:
	354-0056-00			1	RING, ornamental
3	260-0209-00			1	SWITCH, CRT CATHODE SELECTOR, toggle
	- - - - -			-	Mounting Hardware: (not included)
	210-0473-00			1	NUT, switch, $\frac{15}{32}$ -32 x $\frac{5}{64}$ inch
	210-0902-00			1	WASHER, .470 ID x $2\frac{1}{32}$ inch OD
	210-0414-00			1	NUT, hex, $\frac{15}{32}$ -32 x $\frac{9}{16}$ inch
4	129-0064-00			1	POST, binding
	- - - - -			-	Mounting Hardware: (not included)
	358-0181-00			1	BUSHING, nylon, charcoal
	210-0457-00			1	NUT, keps, 6-32 x $\frac{5}{16}$ inch
5	346-0027-00			1	STRAP, ground
6	129-0064-00			1	POST, binding
	- - - - -			-	Mounting Hardware: (not included)
	210-0457-00			1	NUT, keps, 6-32 x $\frac{5}{16}$ inch
7	387-0853-00			1	PLATE, binding post mounting
8	380-0018-00			1	HOUSING, air filter
	- - - - -			-	Mounting Hardware: (not included)
	212-0031-00			2	SCREW, 8-32 x $1\frac{1}{4}$ inches RHS
	210-0458-00			2	NUT, keps, 8-32 x $1\frac{1}{32}$ inch
	210-0402-00			2	NUT, cap, hex, 8-32 x $\frac{5}{16}$ inch
9	334-0649-00			1	TAG, voltage rating
	- - - - -			-	Mounting Hardware: (not included)
	213-0088-00			2	SCREW, thread forming, 4-40 x $\frac{1}{4}$ inch PHS phillips
10	131-0150-00			1	CONNECTOR, chassis mounted, motor base
	- - - - -			-	Consisting Of:
	129-0041-00			1	POST, ground, 4-40 thread one end
	200-0185-00			1	COVER, 3 wire motor base
	205-0014-00			1	SHELL, mounting
	210-0003-00			2	LOCKWASHER, external #4
	210-0551-00			2	NUT, hex, 4-40 x $\frac{1}{4}$ inch
	211-0015-00			1	SCREW, 4-40 x $\frac{1}{2}$ inch RHS
	214-0078-00			2	PIN, connecting
	377-0041-00			1	INSERT, black urea
	- - - - -			-	Mounting Hardware: (not included)
	213-0104-00			2	SCREW, thread forming, 6-32 x $\frac{3}{8}$ inch THS phillips
11	352-0002-00			1	HOLDER, fuse, assembly
	- - - - -			-	Consisting Of:
	352-0010-00			1	HOLDER, fuse
	200-0015-00			1	CAP, fuse
	210-0873-00			1	WASHER, rubber, $\frac{1}{2}$ ID x $1\frac{1}{16}$ inch OD
	- - - - -			1	NUT, fuse holder
12	378-0023-00			1	FILTER, air, foam
	378-0762-00			1	SCREEN, filter (not shown)
	- - - - -			-	Mounting Hardware: (not included)
	213-0104-00			4	SCREW, thread forming, 632 x $\frac{3}{8}$ inch THS phillips

VERTICAL AMPLIFIER CHASSIS

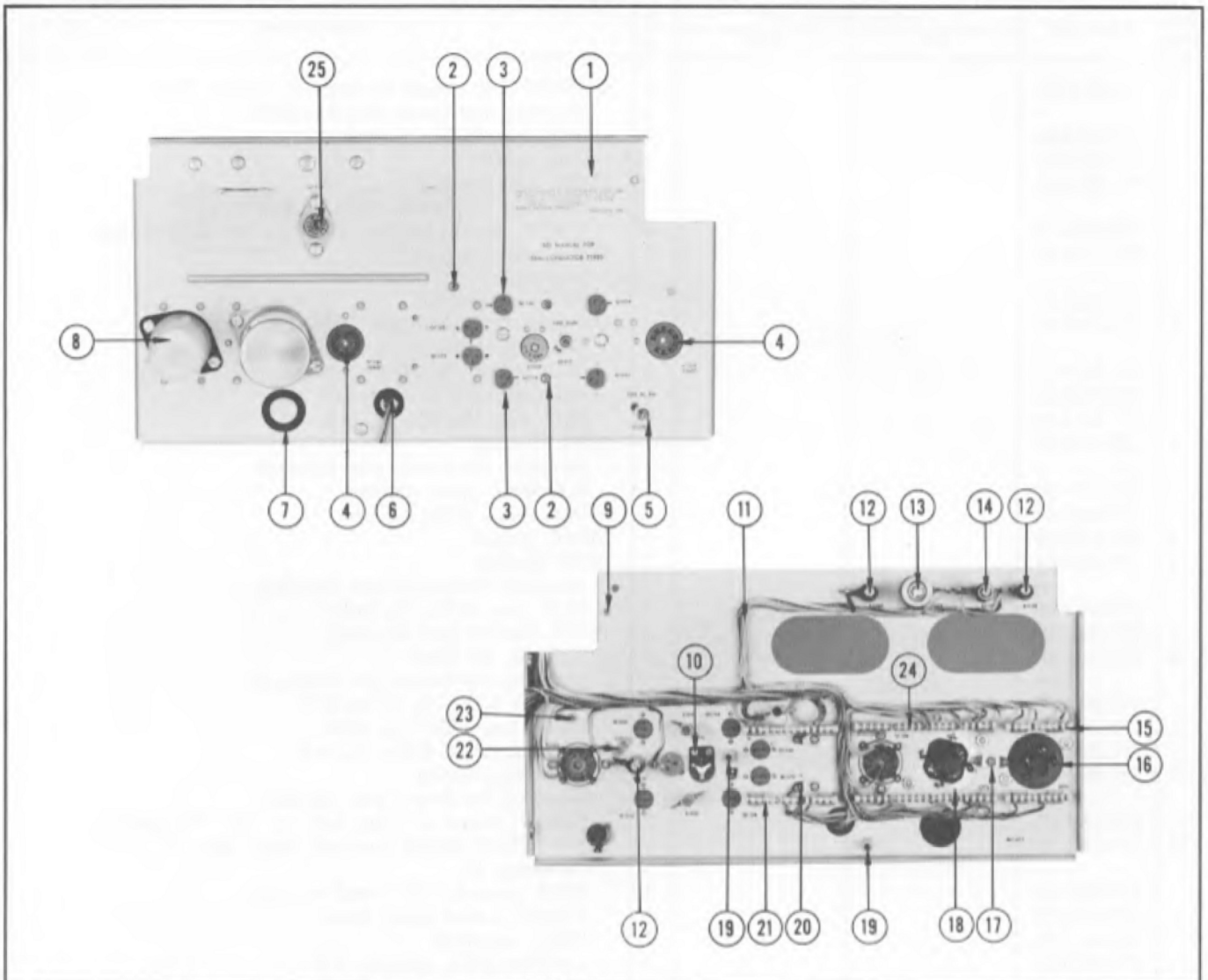

REF. NO.	PART NO.	SERIAL/MODEL NO.		QTY.	DESCRIPTION
		EFF.	DISC.		
1	441-0473-00	100	369	1	CHASSIS, vertical amplifier
	441-0473-01	370		1	CHASSIS, vertical amplifier
	- - - - -			-	Mounting Hardware: (not included)
	212-0004-00			3	SCREW, 8-32 x 5/16 inch BHS
	210-0804-00			3	WASHER, 8S x 3/8 inch
	212-0040-00			1	SCREW, 8-32 x 3/8 inch FHS phillips
	210-0458-00			1	NUT, keps, 8-32 x 11/32 inch
2	- - - - -			-	Mounting Hardware For Each Coil:
	213-0088-00			1	SCREW, thread forming, 4-40 x 1/4 inch PHS phillips
3	136-0095-00	100	209	6	SOCKET, 4 pin transistor
	136-0181-00	210		6	SOCKET, 3 pin transistor
	- - - - -			-	Mounting Hardware For Each: (not included)
	213-0113-00	100	209	2	SCREW, thread forming, 2-36 x 5/16 inch PHS phillips
	354-0234-00	210		1	RING, locking, transistor socket

## VERTICAL AMPLIFIER CHASSIS (Cont'd)

REF. NO.	PART NO.	SERIAL/MODEL NO.		QTY.	DESCRIPTION
		EFF.	DISC.		
4	136-0015-00			2	SOCKET, STM9G
	- - - - -			-	Mounting Hardware For Each: (not included)
	213-0044-00			2	SCREW, thread cutting, 5-32 x 3/16 inch PHS phillips
5	- - - - -			-	Mounting Hardware For Each Miniature Pot:
	210-0583-00			1	NUT, hex, 1/4-32 x 5/16 inch
	210-0940-00			1	WASHER, 1/4 ID x 3/8 inch OD
6	348-0005-00			1	GROMMET, 1/2 inch
7	348-0006-00			1	GROMMET, 3/4 inch
8	200-0257-00			1	COVER, capacitor
9	348-0031-00			1	GROMMET, snap-in
10	- - - - -			-	Mounting Hardware For Capacitor:
	213-0088-00			2	SCREW, thread forming, 4-40 x 1/4 inch PHS phillips
11	179-0839-00	100	369	1	CABLE HARNESS, lower vertical amplifier
	179-0839-01	370		1	CABLE HARNESS, lower vertical amplifier
12	- - - - -			-	Mounting Hardware For Each 5 Watt Resistor:
	211-0544-00			1	SCREW, 6-32 x 3/4 inch THS phillips
	210-0478-00			1	NUT, hex, resistor mounting
	211-0507-00			1	SCREW, 6-32 x 5/16 inch BHS
13	- - - - -			-	Mounting Hardware For 25 Watt Resistor:
	212-0037-00			1	SCREW, 8-32 x 1 3/4 inches Fil HS
	210-0008-00			1	LOCKWASHER, internal, #8
	210-0809-00			1	WASHER, resistor centering
	210-0462-00			1	NUT, hex, resistor mounting
	210-0004-00			1	SCREW, 8-32 x 5/16 inch BHS
14	- - - - -			-	Mounting Hardware For 10 Watt Resistor:
	211-0553-00			1	SCREW, 6-32 x 1 1/2 inches RHS
	210-0601-00			1	EYELET
	210-0478-00			1	NUT, hex, resistor mounting
	210-0203-00			1	LUG, solder, SE6 long
	211-0507-00			1	SCREW, 6-32 x 5/16 inch BHS
15	124-0157-00			2	STRIP, ceramic, 7/16 inch x 9 notches
	- - - - -			-	Each Includes:
	355-0082-00			2	STUD, nylon
	- - - - -			-	Mounting Hardware For Each: (not included)
	361-0039-00			2	SPACER, nylon, 1 1/32 inch
16	386-0252-00			1	Mounting Hardware: (not included)
	- - - - -			-	PLATE, fiber, small capacitor
	211-0534-00			2	SCREW, 6-32 x 5/16 inch PHS with lockwasher
	210-0006-00			2	LOCKWASHER, internal, #6
	210-0407-00			2	NUT, hex, 6-32 x 1/4 inch
17	210-0204-00			1	LUG, solder, DE6
	- - - - -			-	Mounting Hardware: (not included)
	213-0044-00			1	SCREW, thread cutting, 5-32 x 3/16 inch PHS phillips
18	386-0255-00			1	PLATE, metal, small capacitor
	- - - - -			-	Mounting Hardware: (not included)
	211-0534-00			2	SCREW, 6-32 x 5/16 inch PHS with lockwasher
	210-0006-00			2	LOCKWASHER, internal, #6
	210-0407-00			2	NUT, hex, 6-32 x 1/4 inch

VERTICAL AMPLIFIER CHASSIS (Cont'd)

REF. NO.	PART NO.	SERIAL/MODEL NO.		QTY.	DESCRIPTION
		EFF.	DISC.		
19	385-0024-00			2	ROD, aluminum
	- - - - -			-	Mounting Hardware For Each: (not included)
	211-0507-00			1	SCREW, 6-32 x 5/16 inch BHS
	210-0202-00			1	LUG, solder, SE6
20	210-0201-00			2	LUG, solder, SE4
	- - - - -			-	Mounting Hardware For Each: (not included)
	213-0044-00			1	SCREW, thread cutting, 5-32 x 3/16 inch PHS phillips
21	124-0156-00			2	STRIP, ceramic, 7/16 inch x 13 notches
	- - - - -			-	Each Includes:
	355-0082-00			2	STUD, nylon
	- - - - -			-	Mounting Hardware For Each: (not included)
	361-0039-00			2	SPACER, nylon, 1 1/32 inch
22	426-0121-00			1	HOLDER, toroid
	- - - - -			-	Mounting Hardware: (not included)
	361-0007-00			1	SPACER, nylon, .063 inch
23	131-0235-00			3	CONNECTOR, terminal
	- - - - -			-	Mounting Hardware For Each: (not included)
	358-0136-00			1	BUSHING, teflon
24	124-0154-00			2	STRIP, ceramic, 7/16 inch x 20 notches
	- - - - -			-	Each Includes:
	355-0082-00			2	STUD, nylon
	- - - - -			-	Mounting Hardware For Each: (not included)
	361-0039-00			2	SPACER, nylon, 1 1/32 inch
25	- - - - -	X370		1	TRANSISTOR
	- - - - -			-	Mounting Hardware: (not included)
	386-0143-00			1	PLATE, mica insulator
	211-0510-00			2	SCREW, 6-32 x 3/8 inch PHS phillips
	210-0983-00			2	WASHER, shoulder
	210-0802-00			2	WASHER, 6S x 5/16 inch
	210-0006-00	370	489X	1	LOCKWASHER, internal, #6
	210-0202-00			1	LUG, solder, SE6
	210-0407-00	370	489	2	NUT, hex, 6-32 x 1/4 inch
	210-0457-00	490		2	NUT, keps, 6-32 x 5/16 inch

SWEEP CHASSIS

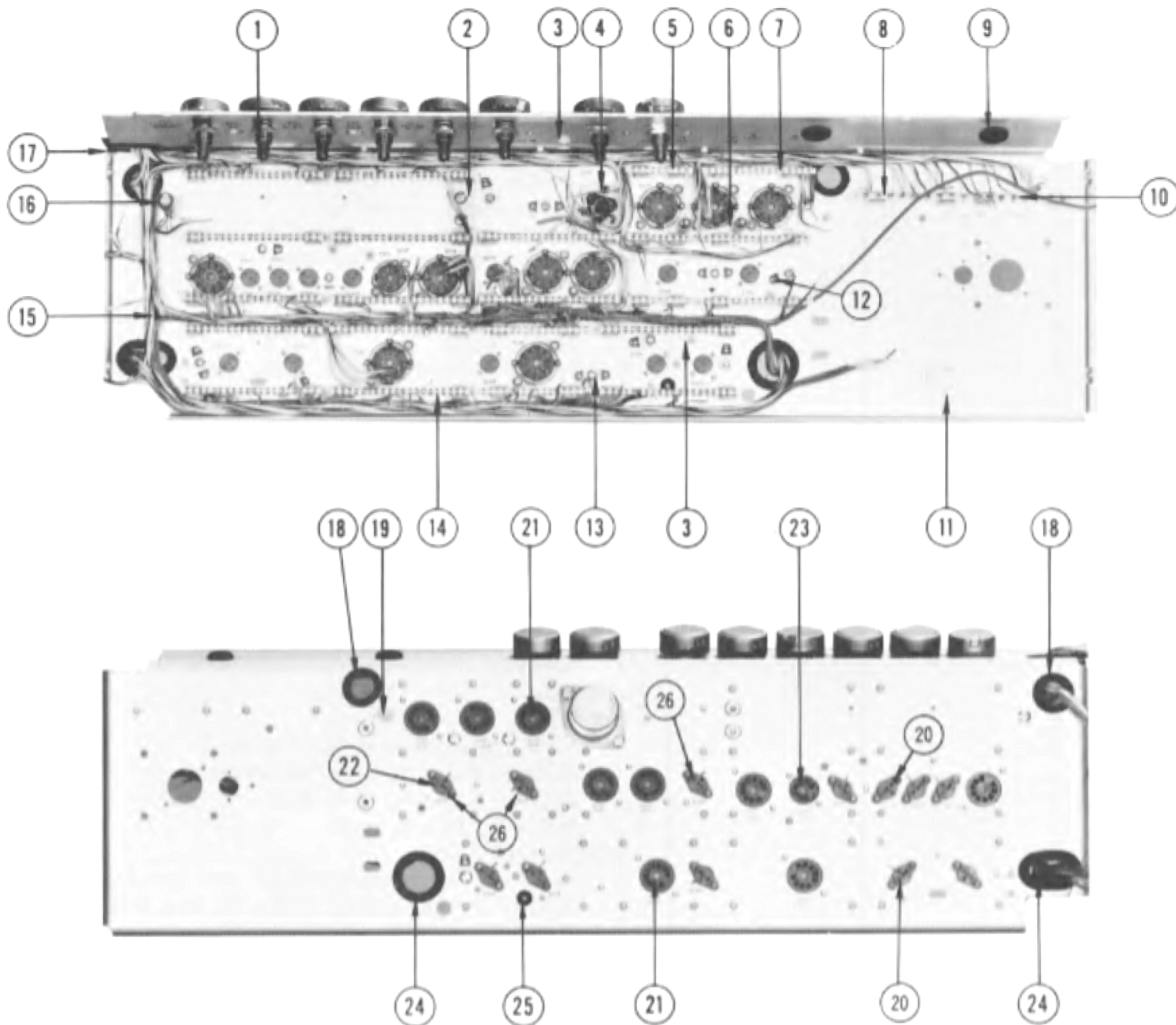

REF. NO.	PART NO.	SERIAL/MODEL NO.		QTY.	DESCRIPTION
		EFF.	DISC.		
1	- - - - - 210-0413-00 210-0840-00			- 1 1	Mounting Hardware For Each Pot: NUT, hex, 3/8-32 x 1/2 inch WASHER, .390 ID x 9/16 inch OD
2	337-0588-00 - - - - - 211-0504-00			1 - 2	SHIELD, sweep generator Mounting Hardware: (not included) SCREW, 6-32 x 1/4 inch BHS
3	348-0031-00			9	GROMMET, snap-in
4	386-0253-00 - - - - - 211-0534-00 210-0006-00 210-0407-00			1 - 2 2 2	PLATE, metal, small capacitor Mounting Hardware: (not included) SCREW, 6-32 x 9/16 inch PHS with lockwasher LOCKWASHER, internal, #6 NUT, hex, 6-32 x 1/4 inch

SWEEP CHASSIS (Cont'd)

REF. NO.	PART NO.	SERIAL/ MODEL NO.		QTY.	DESCRIPTION
		EFF.	DISC.		
5	124-0157-00			3	STRIP, ceramic, 7/16 inch x 9 notches
	-----			-	Each Includes:
	355-0082-00			2	STUD, nylon
	-----			-	Mounting Hardware For Each: (not included)
	361-0039-00			2	SPACER, nylon, 11/32 inch
6	384-0542-00			2	ROD, capacitor mounting
	-----			-	Mounting Hardware For Each: (not included)
	211-0507-00			1	SCREW, 6-32 x 5/16 inch BHS
7	124-0155-00			5	STRIP, ceramic, 7/16 inch x 16 notches
	-----			-	Each Includes:
	355-0082-00			2	STUD, nylon
	-----			-	Mounting Hardware For Each: (not included)
	361-0039-00			2	SPACER, nylon, 11/32 inch
8	124-0095-00			1	STRIP, ceramic, 7/16 inch x 9 notches
	-----			-	Includes:
	355-0046-00			2	STUD, nylon
	-----			-	Mounting Hardware: (not included)
	361-0009-00			2	SPACER, nylon, .281 inch
9	348-0005-00			2	GROMMET, 1/2 inch
10	124-0094-00			1	STRIP, ceramic, 7/16 inch x 7 notches
	-----			-	Includes:
	355-0046-00			2	STUD, nylon
	-----			-	Mounting Hardware: (not included)
	361-0009-00			2	SPACER, nylon, .281 inch
11	441-0520-00			1	CHASSIS, sweep deck
	-----			-	Mounting Hardware: (not included)
	212-0002-00			4	SCREW, 8-32 x 1/4 inch FHS phillips
	212-0004-00			5	SCREW, 8-32 x 5/16 inch BHS
	210-0804-00			5	WASHER, 8S x 3/8 inch
12	210-0201-00			6	LUG, solder, SE4
	-----			-	Mounting Hardware For Each: (not included)
	213-0044-00			1	SCREW, thread cutting, 5-32 x 3/16 inch PHS phillips
13	210-0204-00			5	LUG, solder, DE6
	-----			-	Mounting Hardware For Each: (not included)
	213-0044-00			1	SCREW, thread cutting, 5-32 x 3/16 inch PHS phillips
14	124-0154-00			14	STRIP, ceramic, 7/16 inch x 20 notches
	-----			-	Each Includes:
	355-0082-00			2	STUD, nylon
	-----			-	Mounting Hardware For Each: (not included)
	361-0039-00			2	SPACER, nylon, 11/32 inch
15	179-0821-00			1	CABLE HARNESS, sweep
16	-----			-	Mounting Hardware For 5 Watt Resistor:
	211-0544-00			1	SCREW, 6-32 x 3/4 inch THS phillips
	210-0478-00			1	NUT, hex, resistor mounting
	211-0507-00			1	SCREW, 6-32 x 5/16 inch BHS
17	358-0166-00			1	BUSHING, plastic, black
18	348-0006-00			2	GROMMET, 3/4 inch

## SWEEP CHASSIS (Cont'd)

REF. NO.	PART NO.	SERIAL/MODEL NO.		QTY.	DESCRIPTION
		EFF.	DISC.		
19	385-0033-00			1	ROD, nylon
	- - - - -			-	Mounting Hardware: (not included)
	211-0507-00			1	SCREW, 6-32 x 5/16 inch BHS
20	136-0095-00	100	209	9	SOCKET, 4 pin transistor
	136-0181-00	210		9	SOCKET, 3 pin transistor
	- - - - -			-	Mounting Hardware For Each: (not included)
	213-0113-00	100	209	2	SCREW, thread forming, 2-32 x 5/16 inch RHS phillips
	354-0234-00	210		1	RING, locking, transistor socket
21	136-0015-00			9	SOCKET, STM9G
	- - - - -			-	Mounting Hardware For Each: (not included)
	213-0044-00			2	SCREW, thread cutting, 5-32 x 3/16 inch PHS phillips
22	214-0435-00			2	HEAT SINK, transistor (not shown)
23	136-0008-00			1	SOCKET, STM7G
	- - - - -			-	Mounting Hardware: (not included)
	213-0044-00			2	SCREW, thread cutting, 5-32 x 3/16 inch PHS phillips
24	348-0051-00			2	GROMMET, 15/16 inch
25	348-0002-00			1	GROMMET, 1/4 inch
26	136-0095-00	100	209	3	SOCKET, 4 pin transistor
	136-0182-00	210		3	SOCKET, 4 pin transistor
	- - - - -			-	Mounting Hardware For Each: (not included w/socket)
	213-0113-00	100	209	2	SCREW, thread forming, 2-32 x 5/16 inch RHS, phillips
	354-0234-00	210		1	RING, locking, transistor socket

HIGH VOLTAGE CHASSIS

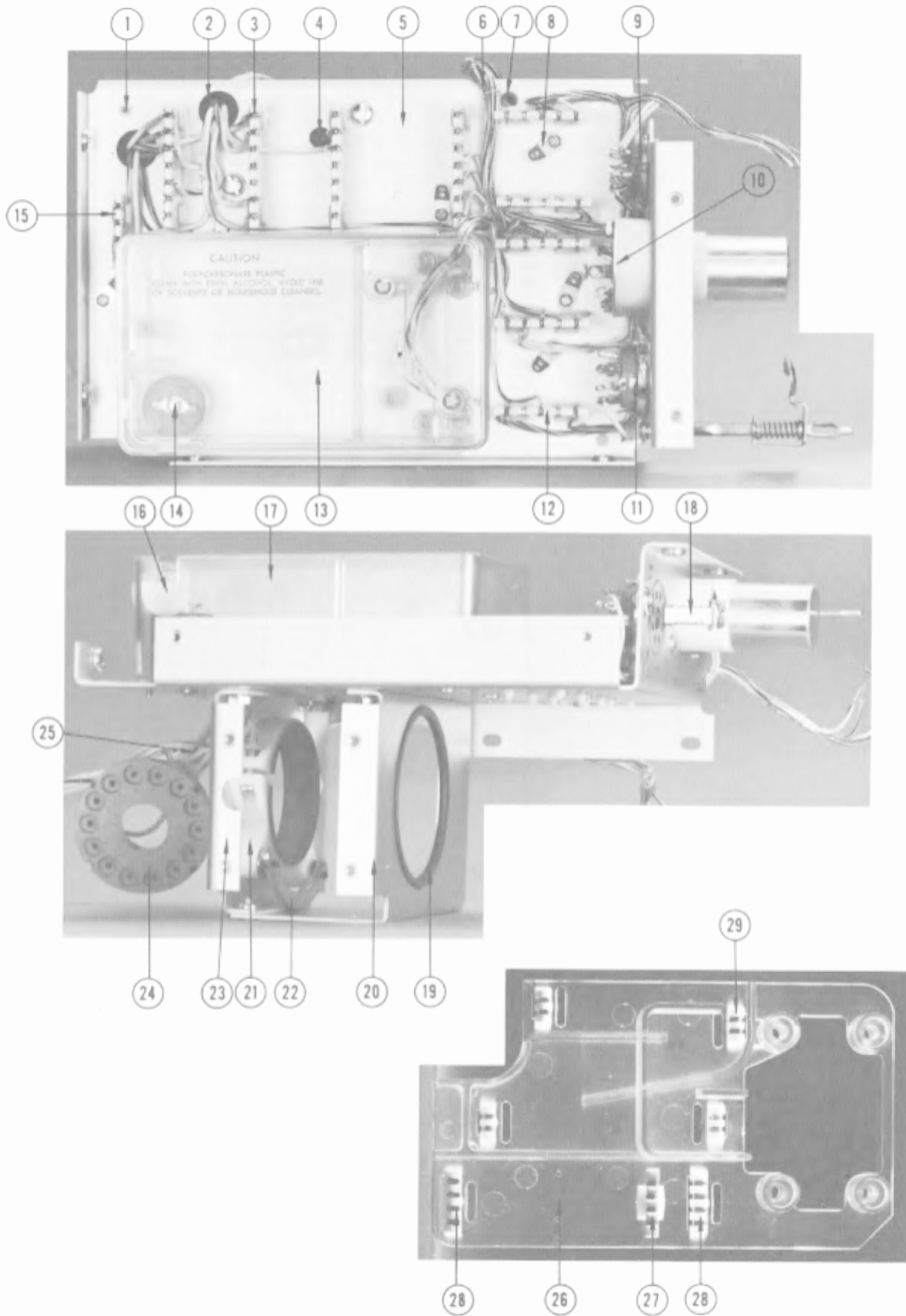



## HIGH VOLTAGE CHASSIS

REF. NO.	PART NO.	SERIAL/MODEL NO.		QTY.	DESCRIPTION
		EFF.	DISC.		
1	348-0031-00			1	GROMMET, snap-in
2	348-0005-00			2	GROMMET, 1/2 inch
3	124-0089-00			4	STRIP, ceramic, 3/4 inch x 7 notches
	- - - - -			-	Each Includes:
	355-0046-00			2	STUD, nylon
	- - - - -			-	Mounting Hardware For Each: (not included)
	361-0008-00			2	SPACER, nylon, .156 inch
4	348-0002-00			1	GROMMET, 1/4 inch
5	441-0475-00			1	CHASSIS, high voltage
	- - - - -			-	Mounting Hardware: (not included)
	212-0002-00			2	SCREW, 8-32 x 1/4 inch FHS phillips
	212-0004-00			2	SCREW, 8-32 x 5/16 inch BHS
	212-0008-00			1	SCREW, 8-32 x 1/2 inch BHS
	210-0804-00			3	WASHER, 8S x 3/8 inch
	210-0458-00			1	NUT, keps, 8-32 x 1 1/32 inch
6	179-0767-00			1	CABLE HARNESS, high voltage
7	348-0055-00			2	GROMMET, plastic, 1/4 inch
8	210-0201-00			4	LUG, solder, SE4
	- - - - -			-	Mounting Hardware For Each: (not included)
	213-0044-00			1	SCREW, thread cutting, 5-32 x 3/16 inch PHS phillips
9	136-0015-00			1	SOCKET, STM9G
	- - - - -			-	Mounting Hardware: (not included)
	213-0044-00			2	SCREW, thread cutting, 5-32 x 3/16 inch PHS phillips
10	386-0253-00			1	PLATE, metal, small capacitor
	- - - - -			-	Mounting Hardware: (not included)
	432-0047-00			1	BASE, small capacitor mounting
	211-0514-00			2	SCREW, 6-32 x 3/4 inch BHS
	210-0006-00			2	LOCKWASHER, internal, #6
	210-0407-00			2	NUT, hex, 6-32 x 1/4 inch
11	136-0011-00			1	SOCKET, STM8
	- - - - -			-	Mounting Hardware: (not included)
	210-0407-00			2	NUT, hex, 6-32 x 1/4 inch
	210-0006-00			2	LOCKWASHER, internal, #6
12	124-0093-00			5	STRIP, ceramic, 3/4 inch x 5 notches
	- - - - -			-	Each Includes:
	355-0046-00			2	STUD, nylon
	- - - - -			-	Mounting Hardware For Each: (not included)
	361-0009-00			2	SPACER, nylon, .281 inch
13	200-0475-00			1	COVER, high voltage
	- - - - -			-	Mounting Hardware: (not included)
	211-0553-00			2	SCREW, 6-32 x 1 1/2 inches RHS phillips
	210-0801-00			2	WASHER, 5S x 7/32 inch
14	- - - - -			-	Mounting Hardware For Capacitor:
	210-0261-00			2	LUG, solder, high voltage
	211-0587-00			1	SCREW, 6-32 x 7/32 inch HHS
	210-0966-00			1	WASHER, insulating, rubber, 7/8 OD x 7/16 inch ID
15	124-0120-00			1	STRIP, ceramic, 7/16 inch x 4 notches
	- - - - -			-	Includes:
	355-0046-00			1	STUD, nylon
	- - - - -			-	Mounting Hardware: (not included)
	361-0008-00			1	SPACER, nylon, .156 inch

HIGH VOLTAGE CHASSIS (Cont'd)

REF. NO.	PART NO.	SERIAL/MODEL NO.		QTY.	DESCRIPTION
		EFF.	DISC.		
16	166-0357-00			1	SLEEVE, high voltage anode lead
	166-0319-00			2	SLEEVE, high voltage
17	380-0048-00			1	HOUSING, high voltage
	- - - - -			-	Mounting Hardware: (not included)
	211-0507-00			3	SCREW, 6-32 x 5/16 inch BHS
18	343-0095-00			1	CLAMP, tube
	- - - - -			-	Mounting Hardware: (not included)
	211-0008-00			1	SCREW, 4-40 x 1/4 inch BHS
	210-0004-00			1	LOCKWASHER, internal, #4
	210-0406-00			1	NUT, hex, 4-40 x 3/16 inch
19	252-0564-00			FT	POLYETHYLENE, extruded channel, cushion, 8 5/8 inches
20	406-0936-00			1	BRACKET, crt mounting
	- - - - -			-	Mounting Hardware: (not included)
	212-0004-00			5	SCREW, 8-32 x 5/16 inch BHS
	210-0804-00			2	WASHER, 8S x 3/8 inch
	210-0458-00			1	NUT, keps, 8-32 x 1 1/32 inch
21	354-0215-00			1	RING, crt clamping assembly
	- - - - -			-	Consisting Of:
	354-0211-00			1	RING, clamping
	211-0560-00			1	SCREW, 6-32 x 1 inch RHS
	210-0407-00			1	NUT, hex, 6-32 x 1/4 inch
	124-0160-00			1	STRIP, liner, crt clamp
22	214-0207-00			1	NUT, adjusting, securing
	- - - - -			-	Mounting Hardware: (not included)
	211-0576-00			2	SCREW, 6-32 x 7/8 inch socket head
	210-0949-00			4	WASHER, 9/64 ID x 1/2 inch OD
23	406-0994-00			1	BRACKET, crt
	- - - - -			-	Mounting Hardware: (not included)
	212-0004-00			1	SCREW, 8-32 x 5/16 inch BHS
	210-0804-00			2	WASHER, 8S x 3/8 x 1 1/32 inch
	210-0458-00			1	NUT, keps, 8-32 x 1 1/32 inch
24	136-0168-00			1	SOCKET, crt, assembly
	- - - - -			-	Includes:
	136-0117-00			1	SOCKET, crt, raw,
	131-0178-00			8	CONNECTOR, cable end, crt
	387-0393-00			1	PLATE, back, crt socket
	- - - - -			-	Mounting Hardware: (not included)
	213-0086-00			2	SCREW, thread cutting, 2-32 x 7/16 inch PHS

## HIGH VOLTAGE CHASSIS (Cont'd)

REF. NO.	PART NO.	SERIAL/MODEL NO.		QTY.	DESCRIPTION
		EFF.	DISC.		
25	179-0769-00			1	CABLE HARNESS, focus and intensity
26	392-0147-00			1	BOARD, high voltage, assembly
	- - - - -			-	Includes:
27	124-0162-00			1	STRIP, ceramic, $\frac{7}{16}$ inch x 4 notches
	- - - - -			-	Includes:
	355-0046-00			1	STUD, nylon
	- - - - -			-	Mounting Hardware: (not included)
	361-0007-00			1	SPACER, nylon, .063 inch
28	124-0164-00			2	STRIP, ceramic, 4 notches
29	124-0163-00			4	STRIP, ceramic, 2 notches
	- - - - -			-	Mounting Hardware: (not included)
	211-0507-00			1	SCREW, 6-32 x $\frac{5}{16}$ inch BHS
	211-0553-00			2	SCREW, 6-32 x $1\frac{1}{2}$ inches RHS phillips
	210-0801-00			2	WASHER, 5S x $\frac{9}{32}$ inch
	358-0228-00			2	BUSHING, insulator

POWER CHASSIS

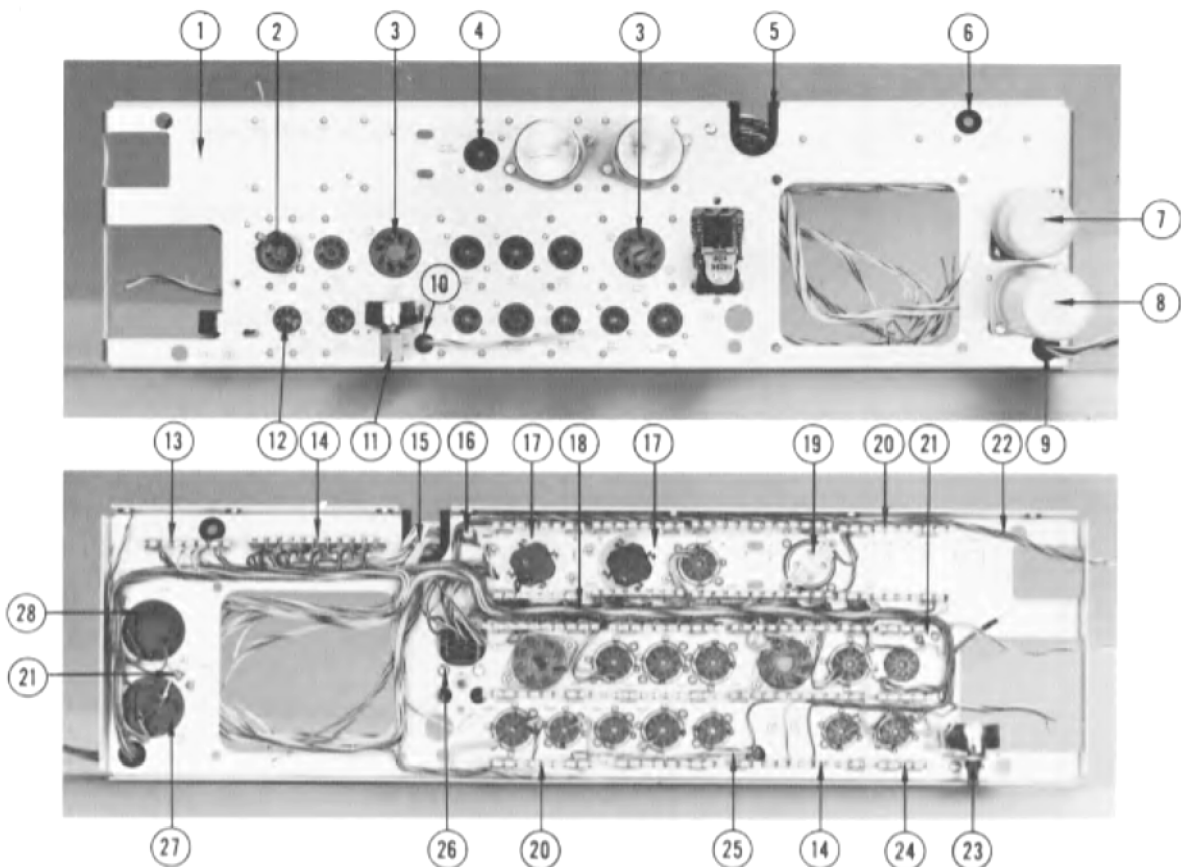

REF. NO.	PART NO.	SERIAL/MODEL NO.		QTY.	DESCRIPTION
		EFF.	DISC.		
1	441-0478-00			1	CHASSIS, power
	- - - - -			-	Mounting Hardware: (not included)
	212-0040-00			5	SCREW, 8-32 x 3/8 inch FHS phillips
	210-0458-00			5	NUT, keps, 8-32 x 1 1/32 inch
	212-0001-00			7	SCREW, 8-32 x 1/4 inch BHS
	210-0804-00			7	WASHER, 85 x 3/8 inch
2	136-0022-00			1	SOCKET, STM9, shielded
	- - - - -			-	Mounting Hardware: (not included)
	213-0044-00			2	SCREW, thread cutting, 5-32 x 3/16 inch PHS phillips
3	136-0013-00			2	SOCKET, STM8
	- - - - -			-	Mounting Hardware For Each: (not included)
	210-0407-00			2	NUT, hex, 6-32 x 1/4 inch
	210-0006-00			2	LOCKWASHER, internal, #6
4	136-0015-00			7	SOCKET, STM9G
	- - - - -			-	Mounting Hardware For Each: (not included)
	213-0044-00			2	SCREW, thread cutting, 5-32 x 3/16 inch PHS phillips
5	358-0166-00			1	BUSHING, plastic, black

## POWER CHASSIS (Cont'd)

REF. NO.	PART NO.	SERIAL/MODEL NO.		QTY.	DESCRIPTION
		EFF.	DISC.		
6	348-0004-00			1	GROMMET, $\frac{3}{8}$ inch
7	200-0560-00			1	COVER, capacitor
8	200-0259-00			1	COVER, capacitor
9	348-0005-00			1	GROMMET, $\frac{1}{2}$ inch
10	348-0003-00			1	GROMMET, $\frac{1}{4}$ inch
11	- - - - -			-	Mounting Hardware For Pot:
	210-0444-00			1	NUT, hex, $\frac{3}{8}$ -32 x $\frac{1}{2}$ x $\frac{5}{8}$ inch
	210-0840-00			1	WASHER, .390 ID x $\frac{9}{16}$ inch OD
	210-0012-00			1	LOCKWASHER, internal, $\frac{3}{8}$ x $\frac{1}{2}$ inch
12	136-0008-00			5	SOCKET, STM7G
	- - - - -			-	Mounting Hardware For Each: (not included)
	213-0044-00			2	SCREW, thread cutting, 5-32 x $\frac{3}{16}$ inch PHS phillips
13	124-0089-00			5	STRIP, ceramic, $\frac{3}{4}$ inch x 7 notches
	- - - - -			-	Each Includes:
	355-0046-00			2	STUD, nylon
	- - - - -			-	Mounting Hardware For Each: (not included)
	361-0009-00			2	SPACER, nylon, .281 inch
14	124-0091-00			6	STRIP, ceramic, $\frac{3}{4}$ inch x 11 notches
	- - - - -			-	Each Includes:
	355-0046-00			2	STUD, nylon
	- - - - -			-	Mounting Hardware For Each: (not included)
	361-0009-00			2	SPACER, nylon, .281 inch
15	179-0835-00			1	CABLE HARNESS, interconnecting
16	- - - - -			-	Mounting Hardware For 5 Watt Resistor:
	211-0544-00			1	SCREW, 6-32 x $\frac{3}{4}$ inch THS phillips
	210-0478-00			1	NUT, hex, resistor mounting
	211-0507-00			1	SCREW, 6-32 x $\frac{5}{16}$ inch BHS
17	386-0255-00			2	PLATE, metal, large capacitor
	- - - - -			-	Mounting Hardware For Each: (not included)
	432-0048-00			1	BASE, large capacitor
	211-0588-00			2	SCREW, 6-32 x $\frac{3}{4}$ inch HHS
	210-0006-00			2	LOCKWASHER, internal, #6
	210-0407-00			2	NUT, hex, 6-32 x $\frac{1}{4}$ inch
18	179-0834-00			1	CABLE HARNESS, power
19	260-0336-00			1	SWITCH, thermal cutout
	- - - - -			-	Mounting Hardware: (not included)
	213-0044-00			2	SCREW, thread cutting, 5-32 x $\frac{3}{16}$ inch PHS phillips
20	124-0090-00			8	STRIP, ceramic, $\frac{3}{4}$ inch x 9 notches
	- - - - -			-	Each Includes:
	355-0046-00			2	STUD, nylon
	- - - - -			-	Mounting Hardware For Each: (not included)
	361-0009-00			2	SPACER, nylon, .281 inch
21	210-0201-00			2	LUG, solder, SE4
	- - - - -			-	Mounting Hardware For Each: (not included)
	213-0044-00			1	SCREW, thread cutting, 5-32 x $\frac{3}{16}$ inch PHS phillips
22	179-0765-00			1	CABLE HARNESS, 110 volt

POWER CHASSIS (Cont'd)

REF. NO.	PART NO.	SERIAL/MODEL NO.		QTY.	DESCRIPTION
		EFF.	DISC.		
23	- - - - -			-	Mounting Hardware For Pot
	210-0444-00			1	NUT, hex, 3/8-32 x 1/2 inch
	210-0840-00			1	WASHER, .390 ID x 9/16 inch OD
24	210-0012-00			1	LOCKWASHER, internal, 3/8 x 1/2 inch
	124-0088-00			3	STRIP, ceramic, 3/4 inch x 4 notches
	- - - - -			-	Each Includes:
	355-0046-00			2	STUD, nylon
	- - - - -			-	Mounting Hardware For Each: (not included)
25	361-0009-00			2	SPACER, nylon, .281 inch
	179-0764-00			1	CABLE HARNESS, 150 volt adjustment
26	- - - - -			-	Mounting Hardware For Relay:
	211-0503-00			2	SCREW, 6-32 x 3/16 inch BHS
27	386-0254-00			1	PLATE, fiber, large capacitor
	- - - - -			-	Mounting Hardware: (not included)
	432-0048-00			1	BASE, large capacitor
	211-0588-00			2	SCREW, 6-32 x 3/4 inch HHS
	210-0006-00			2	LOCKWASHER, internal, #6
	210-0407-00			2	NUT, hex, 6-32 x 1/4 inch
	386-0254-00			1	PLATE, fiber, large capacitor
28	- - - - -			-	Mounting Hardware: (not included)
	211-0543-00			2	SCREW, 6-32 x 5/16 inch RHS
	210-0006-00			2	LOCKWASHER, internal, #6
	210-0407-00			2	NUT, hex, 6-32 x 1/4 inch

CABINET

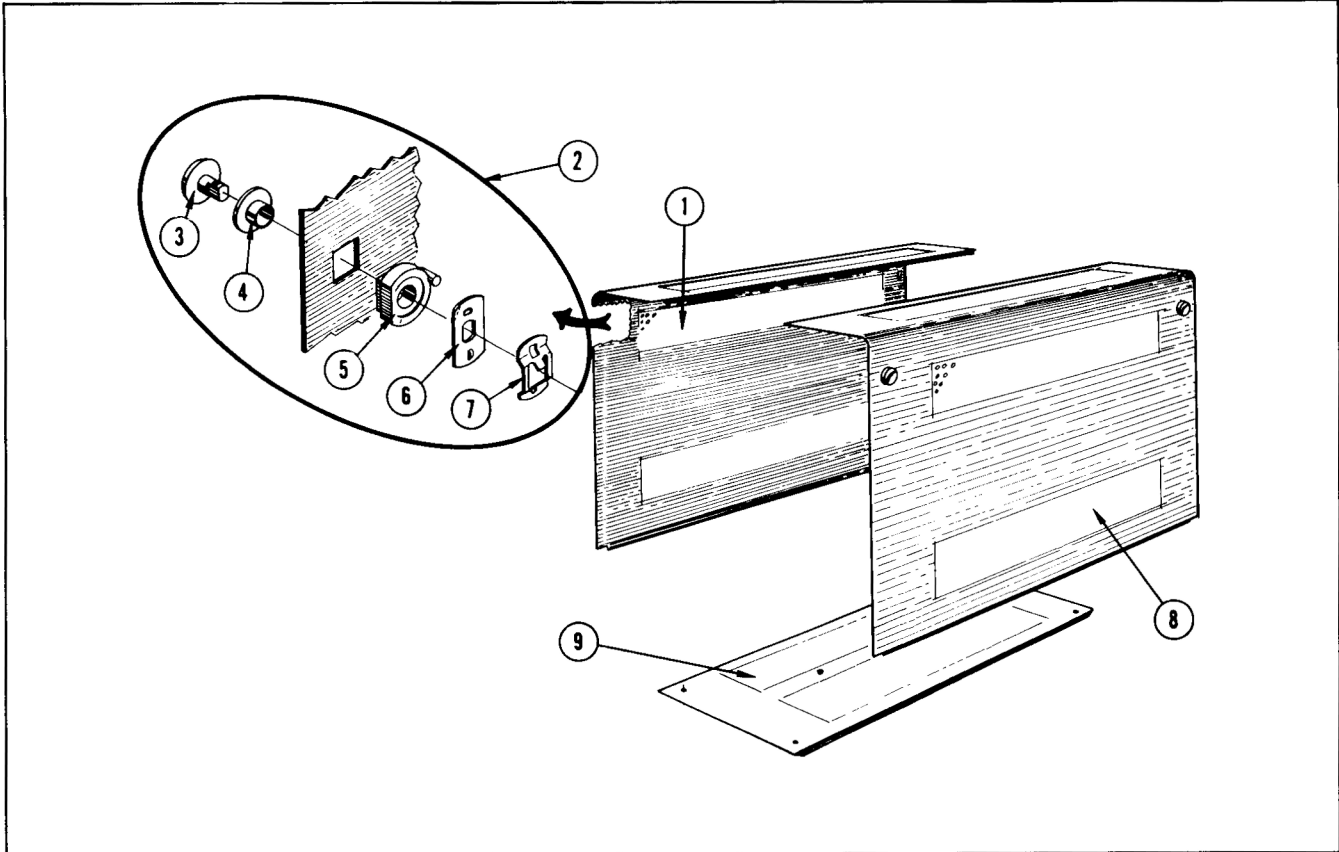

REF. NO.	PART NO.	SERIAL/MODEL NO.		QTY.	DESCRIPTION
		EFF.	DISC.		
1	387-0761-00			1	PLATE, cabinet side, left
	- - - - -			-	Includes:
	134-0028-00			1	PLUG, steel
2	214-0361-00			2	LATCH, quarter turn, assembly
	- - - - -			-	Each Consisting Of:
3	214-0400-00			1	PIN, securing, index
4	358-0218-00			1	BUSHING, latch bearing
5	387-0871-00			1	PLATE, latch index
6	387-0804-00			1	PLATE, latch locking
7	214-0359-00			1	SPRING, latch
8	387-0762-00			1	PLATE, cabinet side, right
	- - - - -			-	Includes:
	214-0361-00			2	LATCH, quarter turn, assembly
9	387-0756-00			1	PLATE, cabinet, bottom
	- - - - -			-	Includes:
	214-0361-00			4	LATCH, quarter turn, assembly

ACCESSORIES

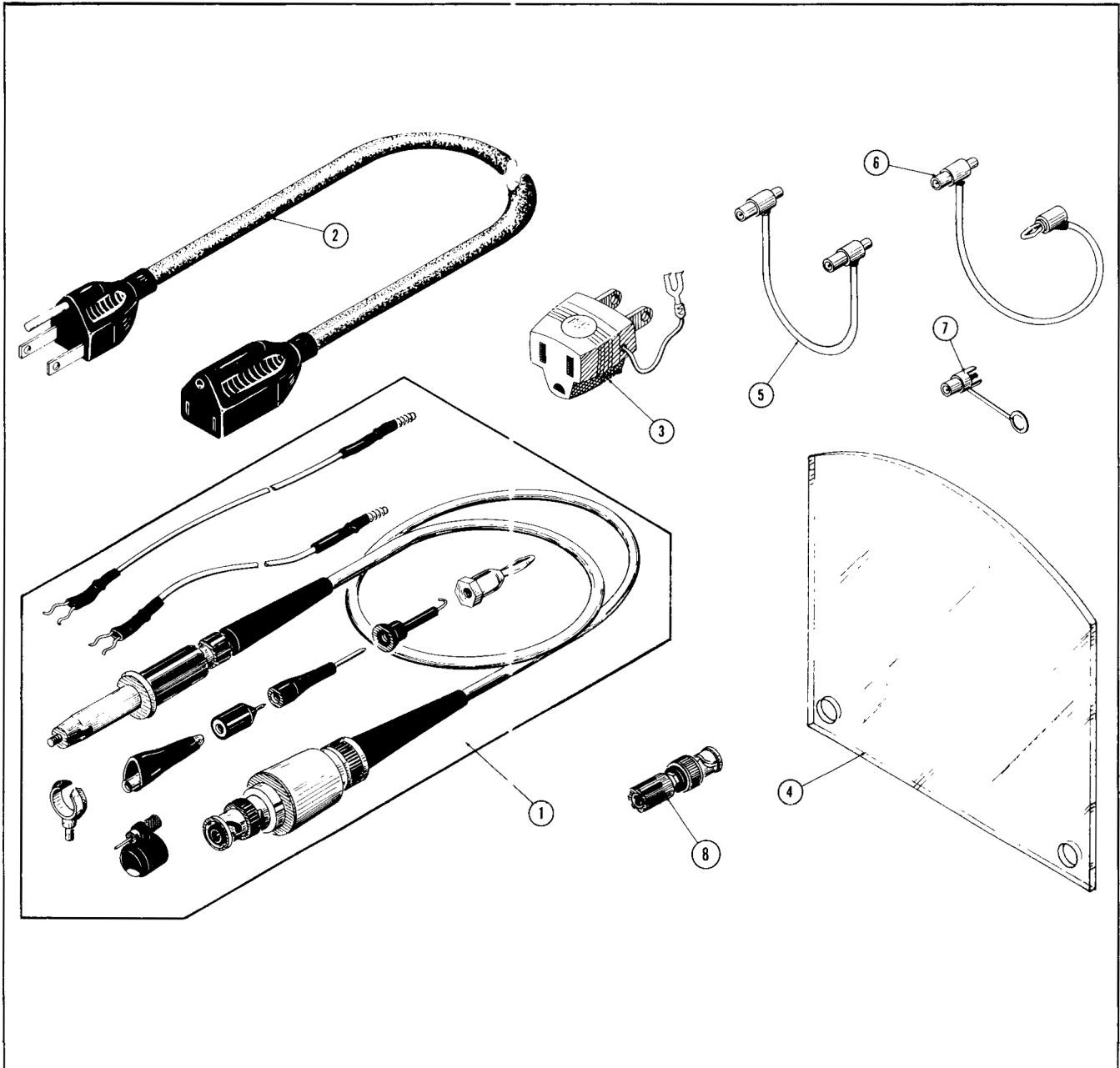

REF. NO.	PART NO.	SERIAL/MODEL NO.		QTY.	DESCRIPTION
		EFF.	DISC.		
1	010-0129-00			2	PROBE, package, P6008
2	161-0010-00			1	CORD, power
3	103-0013-00			1	ADAPTER, 3 to 2 wire
4	387-0918-00			1	PLATE, protector
	378-0545-00	100	389	1	FILTER, light, smoke gray (installed)
	378-0567-00	390		1	FILTER, light, smoke gray (installed)
5	012-0031-00	100	279	2	CORD, patch
	012-0087-00	280		2	CORD, patch
6	012-0091-00	X280		1	CORD, patch
7	012-0092-00	X280		1	JACK, BNC — post
8	103-0033-00	100	279X	2	ADAPTER, BNC to binding post (not shown)
- -	070-0418-00			2	MANUAL, instruction (not shown)



## ELECTRICAL PARTS

Values are fixed unless marked Variable.

Ckt. No.	Tektronix Part No.	Description	S/N Range
<b>Bulbs</b>			
B289	150-030	Neon, NE-2V	READY
B290W	150-030	Neon, NE-2V	UNCALIBRATED
B294	150-027	Neon, NE-23	
B520	150-030	Neon, NE-2V	MAG ON
B559	150-030	Neon, NE-2V	UNCALIBRATED
B579	150-037	Neon, ST2-27S	
B583	150-027	Neon, NE-23	
B589	150-037	Neon, ST2-27S	
B602	150-001	Incandescent, #47	Pilot Light
B603	150-031	Incandescent, #44	Graticule Light
B604	150-031	Incandescent, #44	Graticule Light
B1184	150-030	Neon, NE-2V	
B1194	150-030	Neon, NE-2V	

## Capacitors

Tolerance  $\pm 20\%$  unless otherwise indicated.

Tolerance of all electrolytic capacitors as follows (with exceptions):

$$3 \text{ V} - 50 \text{ V} = -10\%, +250\%$$

$$51 \text{ V} - 350 \text{ V} = -10\%, +100\%$$

$$351 \text{ V} - 450 \text{ V} = -10\%, +50\%$$

C201	283-001	0.005 $\mu\text{f}$	Cer	500 v	
C202	281-523	100 pf	Cer	350 v	
C204	283-002	0.01 $\mu\text{f}$	Cer	500 v	
C205	283-000	0.001 $\mu\text{f}$	Cer	500 v	
C206	281-512	27 pf	Cer	500 v	10%
C211	283-001	0.005 $\mu\text{f}$	Cer	500 v	
C212	281-523	100 pf	Cer	350 v	
C218	283-000	0.001 $\mu\text{f}$	Cer	500 v	
C241	281-523	100 pf	Cer	350 v	
C243	281-525	470 pf	Cer	500 v	
C249	283-006	0.02 $\mu\text{f}$	Cer	600 v	
C253	283-000	0.001 $\mu\text{f}$	Cer	500 v	
C256	281-576	11 pf	Cer	500 v	5%
C267	283-026	0.2 $\mu\text{f}$	Cer	25 v	
C276	290-187	4.7 $\mu\text{f}$	EMT	35 v	20%
C278	283-003	0.01 $\mu\text{f}$	Cer	150 v	
C283	281-524	150 pf	Cer	500 v	
C290A	281-007	3-12 pf	Cer	Var	
C290B	281-007	3-12 pf	Cer	Var	
C290C	281-010	4.5-25 pf	Cer	Var	

Parts List—Type 544

Capacitors (Cont'd)

Ckt. No.	Tektronix Part No.		Description		S/N Range
C290D	281-574	82 pf	Cer	500 v	10%
C290E	*295-073	0.001 $\mu$ f	Timing Series		
C290F		0.01 $\mu$ f			
C290G		0.1 $\mu$ f			
C290H		1 $\mu$ f			
C290J		10 $\mu$ f			
C292	283-001	0.005 $\mu$ f	Cer	500 v	
C294	281-528	82 pf	Cer	500 v	10%
C296	283-006	0.02 $\mu$ f	Cer	600 v	
C299	Use 281-010	4.5-25 pf	Cer	500 v	10%
C301	281-519	47 pf	Cer		
C303	283-000	0.001 $\mu$ f	Cer	500 v	
C311	283-000	0.001 $\mu$ f	Cer	500 v	
C314	283-002	0.01 $\mu$ f	Cer	500 v	
C328	281-550	120 pf	Cer	500 v	10%
C329	281-519	47 pf	Cer	500 v	10%
C330A	281-550	120 pf	Cer	500 v	10%
C330B	285-543	0.0022 $\mu$ f	PTM	400 v	
C330C	285-636	0.022 $\mu$ f	PTM	200 v	
C330D	285-633	0.22 $\mu$ f	PTM	100 v	10%
C330E	285-576	1 $\mu$ f	PTM	100 v	10%
C337	281-523	100 pf	Cer	350 v	
C344	283-002	0.01 $\mu$ f	Cer	500 v	
C346	281-512	27 pf	Cer	500 v	10%
C365	281-543	270 pf	Cer	500 v	10%
C369	281-546	330 pf	Cer	500 v	10%
C370	281-605	200 pf	Cer	500 v	
C375	281-544	5.6 pf	Cer	500 v	10%
C380	281-0536-00	1000 pf	Cer	500 v	10%
C382	283-006	0.02 $\mu$ f	Cer	600 v	
C392	283-006	0.02 $\mu$ f	Cer	600 v	
C397	283-006	0.02 $\mu$ f	Cer	600 v	
C398	283-002	0.01 $\mu$ f	Cer	500 v	
C399	283-002	0.01 $\mu$ f	Cer	500 v	
C502A	281-625	35 pf	Cer	500 v	5%
C502C	281-007	3-12 pf	Cer	100 v	10%
C502D	285-659	0.001 $\mu$ f	PTM		
C503A	281-579	21 pf	Cer	500 v	5%
C503C	281-012	7-45 pf	Cer	500 v	
C503D	281-560	198 pf	Cer		
C516	283-001	0.005 $\mu$ f	Cer	500 v	
C520	283-000	0.001 $\mu$ f	Cer	500 v	
C524	281-010	4.5-25 pf	Cer	500 v	
C525	281-557	1.8 pf	Cer		
C538	281-549	68 pf	Cer	500 v	10%
C541	283-002	0.01 $\mu$ f	Cer	500 v	
C544	281-549	68 pf	Cer	500 v	10%

## Capacitors (Cont'd)

Ckt. No.	Tektronix Part No.	Description	S/N Range
C557D	281-009	3-12 pf	Cer Var
C557F	281-013	8-50 pf	Cer Var
C557H	281-013	8-50 pf	Cer Var
C557J	Use 281-549	68 pf	Cer 500 v 10%
C557K	281-013	8-50 pf	Cer Var
C557L	281-623	650 pf	Cer 500 v 5%
C559	283-000	0.001 $\mu$ f	Cer 500 v
C567	283-104	0.002 $\mu$ f	Cer 500 v 5%
C572	281-022	8-50 pf	Cer Var
C574	283-001	0.005 $\mu$ f	Cer 500 v
C576	281-053	0.35-1.37 pf	Poly Var
C579	283-068	0.01 $\mu$ f	Cer 500 v
C582	281-022	8-50 pf	Cer Var
C584	283-001	0.005 $\mu$ f	Cer 500 v
C586	281-053	0.35-1.37 pf	Poly Var
C589	283-068	0.01 $\mu$ f	Cer 500 v
C591	281-036	3-12 pf	Cer Var
C592	283-002	0.01 $\mu$ f	Cer 500 v
C598	285-628	0.033 $\mu$ f	PTM 300 v
C599	283-000	0.001 $\mu$ f	Cer 500 v
C600	285-519	0.047 $\mu$ f	PTM 400 v
C610	285-510	0.01 $\mu$ f	PTM 400 v
C617	285-519	0.047 $\mu$ f	PTM 400 v
C628	285-510	0.01 $\mu$ f	PTM 400 v
C636	281-519	47 pf	Cer 500 v 10%
C640	283-022	0.02 $\mu$ f	Cer 1400 v
C642A,B	*290-242	250 $\mu$ f x 40 $\mu$ f	EMC 350 v/250 v
C650	285-510	0.01 $\mu$ f	PTM 400 v
C665	283-001	0.005 $\mu$ f	Cer 500 v X290-up
C694	281-523	100 pf	Cer 350 v
C670	283-022	0.02 $\mu$ f	Cer 1400 v
C671	*290-240	300 $\mu$ f	FMC 250 v
C680	285-510	0.01 $\mu$ f	PTM 400 v
C688	285-510	0.01 $\mu$ f	PTM 400 v
C701	*290-241	200 $\mu$ f	PTM 400 v
C709A } C709B } C709C }	*290-238	10 $\mu$ f } 10 $\mu$ f } 20 $\mu$ f }	EMC 450 v } 350 v } 250 v }
C710	285-511	0.01 $\mu$ f	PTM 600 v
C730	*290-239	125 $\mu$ f	EMC 250 v
C754	283-002	0.01 $\mu$ f	Cer 500 v
C756	283-002	0.01 $\mu$ f	Cer 500 v
C760	281-549	68 pf	Cer 500 v 10%
C765	281-505	12 pf	Cer 500 v 10%
C767	283-003	0.01 $\mu$ f	Cer 150 v
C768	281-604	2.2 pf	Cer 500 v $\pm$ 0.25 pf
C769	283-006	0.02 $\mu$ f	Cer 600 v
C770	283-002	0.01 $\mu$ f	Cer 500 v

Parts List—Type 544

Capactors (Cont'd)

Ckt. No.	Tektronix Part No.		Description		S/N Range
C771	*290-229	2 x 40 $\mu$ f	EMC	250 v	
C772	283-002	0.01 $\mu$ f	C $\epsilon$ r	500 v	
C773A } C773B } C773C }	*290-237	40 $\mu$ f } 20 $\mu$ f } 20 $\mu$ f }	EMC	250 v 350 v 450 v	
C774	283-002	0.01 $\mu$ f	C $\epsilon$ r	500 v	
C775	283-002	0.01 $\mu$ f	C $\epsilon$ r	500 v	
C777	283-002	0.01 $\mu$ f	C $\epsilon$ r	500 v	
C802	*290-243	40 $\mu$ f	EMC	400 v	
C803	283-000	0.001 $\mu$ f	C $\epsilon$ r	500 v	
C806	285-506	0.0047 $\mu$ f	C $\epsilon$ r	400 v	
C808	285-502	0.001 $\mu$ f	PT/A	1000 v	
C820	283-082	0.001 $\mu$ f	C $\epsilon$ r	4000 v	
C821	283-082	0.001 $\mu$ f	C $\epsilon$ r	4000 v	
C822	281-525	470 pf	C $\epsilon$ r	500 v	
C823	283-101	0.0047 $\mu$ f	C $\epsilon$ r	6000 v	
C828	281-536	0.001 $\mu$ f	C $\epsilon$ r	500 v	10%
C829	283-082	0.01 $\mu$ f	C $\epsilon$ r	4000 v	
C830	283-082	0.01 $\mu$ f	C $\epsilon$ r	4000 v	
C832	283-002	0.01 $\mu$ f	C $\epsilon$ r	500 v	
C833	281-556	500 pf	C $\epsilon$ r	10000 v	
C834	281-556	500 pf	C $\epsilon$ r	10000 v	
C836	283-096	500 pf	C $\epsilon$ r	20000 v	
C841	283-006	0.02 $\mu$ f	C $\epsilon$ r	600 v	
C842	283-082	0.01 $\mu$ f	C $\epsilon$ r	4000 v	
C852	283-082	0.01 $\mu$ f	C $\epsilon$ r	4000 v	
C854	283-082	0.01 $\mu$ f	C $\epsilon$ r	4000 v	
C858	283-082	0.01 $\mu$ f	C $\epsilon$ r	4000 v	
C863	283-002	0.01 $\mu$ f	C $\epsilon$ r	500 v	
C932	283-041	0.0033 $\mu$ f	C $\epsilon$ r	500 v	5%
C934	283-032	470 pf	C $\epsilon$ r	500 v	5%
C939	283-057	0.1 $\mu$ f	C $\epsilon$ r	200 v	
C941	283-006	0.02 $\mu$ f	C $\epsilon$ r	600 v	
C944	283-057	0.1 $\mu$ f	C $\epsilon$ r	200 v	
C958	281-525	470 pf	C $\epsilon$ r	500 v	
C965	281-523	100 pf	C $\epsilon$ r	350 v	
C1000	281-601	7.5 pf	C $\epsilon$ r	500 v	$\pm$ 0.5 pf
C1002	283-001	0.005 $\mu$ f	C $\epsilon$ r	500 v	
C1014	283-067	0.001 $\mu$ f	C $\epsilon$ r	200 v	10%
C1016	281-519	47 pf	C $\epsilon$ r	500 v	10%
C1019	Use 281-0505-00	12 pf	C $\epsilon$ r	500 v	10% X230-up
C1024	283-067	0.001 $\mu$ f	C $\epsilon$ r	200 v	10%
C1026	281-519	47 pf	C $\epsilon$ r	500 v	10%
C1027	281-558	18 pf	C $\epsilon$ r	500 v	
C1028	283-001	0.005 $\mu$ f	C $\epsilon$ r	500 v	
C1029	281-006	1.5-7 pf	C $\epsilon$ r	Var	

## Capacitors (Cont'd)

Ckt. No.	Tektronix Part No.		Description		S/N Range
C1031	281-572	6.8 pf	Cer	500 v	10%
C1035	283-067	0.001 $\mu$ f	Cer	200 v	10%
C1038	283-067	0.001 $\mu$ f	Cer	200 v	10%
C1042	281-572	6.8 pf	Cer	500 v	10%
C1048	283-067	0.001 $\mu$ f	Cer	200 v	10%
C1069	283-067	0.001 $\mu$ f	Cer	200 v	10%
C1071	283-067	0.001 $\mu$ f	Cer	200 v	10%
C1074	281-503	8 pf	Cer	500 v	$\pm 0.5$ pf
C1076	281-075	5-25 pf	Cer	Var	
C1077	281-549	68 pf	Cer	500 v	10%
C1087	283-067	0.001 $\mu$ f	Cer	200 v	10%
C1103	281-511	22 pf	Cer	500 v	10%
C1104	281-524	150 pf	Cer	500 v	
C1105	281-075	5-25 pf	Cer	Var	
C1106	281-075	5-25 pf	Cer	Var	
C1107	281-600	35 pf	Cer		10%
C1113	283-067	0.001 $\mu$ f	Cer	200 v	10%
C1116	283-001	0.005 $\mu$ f	Cer	500 v	
C1124	281-524	150 pf	Cer	500 v	
C1126	281-075	5-25 pf	Cer	Var	
C1127	Use 281-558	18 pf	Cer	500 v	
C1132	283-067	0.001 $\mu$ f	Cer	200 v	10%
C1142	283-067	0.001 $\mu$ f	Cer	200 v	10%
C1152	283-067	0.001 $\mu$ f	Cer	200 v	10%
C1153	283-001	0.005 $\mu$ f	Cer	500 v	
C1157	Use 283-0057-00	0.1 $\mu$ f	Cer	200 v	
C1161	283-001	0.005 $\mu$ f	Cer	500 v	
C1163	283-006	0.02 $\mu$ f	Cer	600 v	
C1181	283-067	0.001 $\mu$ f	Cer	200 v	10%
C1191	283-067	0.001 $\mu$ f	Cer	200 v	10%

## Diodes

D245	152-154	Tunnel	TD253	10 MA	
D257	*152-075	Germanium	Tek Spec		
D259	*152-075	Germanium	Tek Spec		
D269	152-141	Silicon	1N3605		
D271	152-141	Silicon	1N3605		
D277	152-119	Zener	1N969A	.4 w, 22 v, 10%	
D279	152-141	Silicon	1N3605		
D283	*152-075	Germanium	Tek Spec		
D285	Use *152-0125-00	Tunnel	Selected TD3A	4.7 MA	
D286	*152-161	Tek	GaAs		
D290	*152-0165-00	Silicon	Tek Spec		X480-up
D297	152-118	Zener	1N3033	1 w, 36 v, 20%	
D298	*152-061	Silicon	Tek Spec		
D300	*152-061	Silicon	Tek Spec		

**Parts List—Type 544**

**Diodes (Cont'd)**

Ckt. No.	Tektronix Part No.	Description	S/N Range
D329	*152-061	Silicon Tek Sp:c	
D332	*152-061	Silicon Tek Sp:c	
D347	152-141	Silicon 1N3615	
D362	152-141	Silicon 1N3615	
D363	152-141	Silicon 1N3615	
D367	152-141	Silicon 1N3615	
D372	*152-061	Silicon Tek Sp:c	
D541	152-067	Zener 1M25Z10	1 w, 25 v, 10%
D542	*152-075	Germanium Tek Sp:c	
D561	*152-075	Germanium Tek Sp:c	
D582	*152-061	Silicon Tek Sp:c	
D642A,B,C,D	152-066	Silicon 1N3114	
D672A,B,C,D	*152-047	Replaceable by 1N2862	
D693	152-157	Zener .4M140Z10	.4 w, 140 v, 10%
D702A,B	152-066	Silicon 1N3114	
D732A,B	152-066	Silicon 1N3114	
D759	152-141	Silicon 1N3615	
D769	*152-061	Silicon Tek Sp:c	
D831	152-0208-00	Silicon 1N3115	X310-up
D942	*152-061	Silicon Tek Sp:c	
D948	152-004	Zener 1N707 or 1N713	1/4 w, 6.2 v-8 v 100-469X
D1014	152-141	Silicon 1N3615	
D1018	152-120	Zener 1N3021B	1 w, 10 v, 5%
D1024	152-141	Silicon 1N3615	
D1109	152-0228-00	Zener 3/4M105Z10	1 w, 105 v, 10% X370-up

**Fuses**

F601	159-011	6.25 Amp 3AG Slo-B'o, 115 v, 50-60 and 400 cps
	159-005	3 Amp 3AG Slo-B'o, 230 v, 50-60 and 400 cps

**Connector**

J11	131-018	16 contact, female, chassis mounted
-----	---------	-------------------------------------

**Inductors**

LR221	*108-230	3.25 $\mu$ h (on a 150 $\Omega$ 1/2 w 5% resistor)
LR223	*108-230	3.25 $\mu$ h (on a 150 $\Omega$ 1/2 w 5% resistor)
L244	276-507	Core, Ferramic Suppressor
L252	*108-147	2.2 $\mu$ h
L256	*108-215	1.1 $\mu$ h
L553	*119-030	Delay Line Assembly
L760	108-240	820 $\mu$ h
L778	Use *108-323	Beam Rotator
L1013	*108-260	0.1 $\mu$ h
L1018	*120-266	Toroid, 10T Single
L1023	*108-260	0.1 $\mu$ h

## Inductors (Cont'd)

Ckt. No.	Tektronix Part No.	Description	S/N Range
L1030	*108-264	0.2 $\mu$ h	
L1040	*108-264	0.2 $\mu$ h	
L1051	*108-260	0.1 $\mu$ h	
LR1052	*108-288	1.2 $\mu$ h (on a $62\ \Omega$ $\frac{1}{2}$ w 5% resistor)	
L1061	*108-260	0.1 $\mu$ h	
LR1062	*108-288	1.2 $\mu$ h (on a $62\ \Omega$ $\frac{1}{2}$ w 5% resistor)	
L1072	*108-260	0.1 $\mu$ h	
L1082	*108-260	0.1 $\mu$ h	
LR1115	*131-335	0.5 $\mu$ h (on a $330\ \Omega$ $\frac{1}{4}$ w resistor) (brown)	
LR1135	*131-336	0.5 $\mu$ h (on a $330\ \Omega$ $\frac{1}{4}$ w resistor) (blue)	
L1144	*108-095	1.4 $\mu$ h	
L1154	*108-095	1.4 $\mu$ h	
L1157	*114-080	6.8 $\mu$ h-14.6 $\mu$ h	Var Core 276-0506-00
L1160	276-528	Core, Ferramic suppressor	
L1170	276-528	Core, Ferramic suppressor	

## Relays

K600	148-021	Tube Relay
K601	*148-019	Tek Spec

## Transistors

Q234	151-089	2N962	
Q244	151-089	2N962	
Q265	*151-108	Replaceable by 2N2501	
Q275	*151-108	Replaceable by 2N2501	
Q284	*151-108	Replaceable by 2N2501	
Q289	*151-096	Selected from 2N1893	
Q303	151-089	2N962	
Q373	151-063	2N2207	
Q534	*151-121	Selected from TA1938	
Q543	*151-096	Selected from 2N1893	
Q554	151-063	2N2207	
Q564	151-063	2N2207	
Q1014	*153-525	Matched pair	
Q1024			
Q1034	*153-527	Matched pair	
Q1044			
Q1074	*153-525	Matched pair	
Q1084			
Q1104†	*153-526		
Q1109	151-0149-00	2N3441	X370-up
Q1114††	*153-524		

†Q1104 and Q1124 furnished as a matched pair.

††Q1114 and Q1134 furnished as a matched pair.

Parts List—Type 544

Transistors (Cont'd)

Ckt. No.	Tektronix Part No.	Description	S/N Range
Q1124†	*153-526		
Q1134††	*153-524		
Q1144	*153-527	Matched pair	
Q1154			
Q1163	*151-127	Selected from 2N2369	
Q1173	*151-127	Selected from 2N2369	

Resistors

Resistors are fixed, composition,  $\pm 10\%$  unless otherwise indicated.

R205	302-104	100 k	1/2 w			
R206	321-385	100 k	1/8 w		Prec	1%
R207	323-406	165 k	1/2 w		Prec	1%
R209	311-018	20 k		Var		INT TRIG DC LEVEL
R210	316-103	10 k	1/4 w			
R211	316-222	2.2 k	1/4 w			
R213	323-481	1 meg	1/4 w		Prec	1%
R214	302-155	1.5 meg	1/2 w			
R215†††	311-426	300 k		Var		TRIGGERING LEVEL
R216	302-394	390 k	1/2 w			
R217	302-335	3.3 meg	1/2 w			
R218	302-104	100 k	1/2 w			
R219	316-105	1 meg	1/4 w			
R220	316-470	47 $\Omega$	1/4 w			
R221	316-221	220 $\Omega$	1/4 w			
R222	316-470	47 $\Omega$	1/4 w			
R223	316-221	220 $\Omega$	1/4 w			
R224	308-108	15 k	5 w		WW	5%
R225	311-004	200 $\Omega$		Var		TRIGGER LEVEL CENTERING
R227	308-267	7.5 k	5 w		WW	5%
R228	302-102	1 k	1/2 w			
R236	324-335	30.1 k	1 w		Prec	1%
R241	316-221	220 $\Omega$	1/4 w			
R243	316-100	10 $\Omega$	1/4 w			
R244	323-001	10 $\Omega$	1/2 w		Prec	1%
R245	311-308	50 $\Omega$	2 w	Var		TRIGGER SENS
R247	324-306	15 k	1 w		Prec	1%
R248	324-306	15 k	1 w		Prec	1%
R249	302-101	100 $\Omega$	1/2 w			
R253	323-370	69.8 k	1/2 w		Prec	1%
R254	323-140	280 $\Omega$	1/2 w		Prec	1%
R257	302-224	220 k	1/2 w			
R263	316-470	47 $\Omega$	1/4 w			
R265	301-303	30 k	1/2 w			5%
R267	301-912	9.1 k	1/2 w			5%

†Q1104 and Q1124 furnished as a matched pair.

††Q1114 and Q1134 furnished as a matched pair.

†††Furnished as a unit with SW215.



## Resistors (Cont'd)

Ckt. No.	Tektronix Part No.		Description		S/N Range
R269	302-103	10 k	1/2 w		
R271	303-513	51 k	1 w		5%
R275	301-513	51 k	1/2 w		5%
R276	302-471	470 Ω	1/2 w		
R278	301-752	7.5 k	1/2 w		5%
R279	302-152	1.5 k	1/2 w		
R281	316-101	100 Ω	1/4 w		
R282	323-333	28.7 k	1/2 w	Prec	1%
R283	316-394	390 k	1/4 w		
R284	305-153	15 k	2 w		5%
R285	301-102	1 k	1/2 w		5%
R286	303-513	51 k	1 w		5%
R287	301-273	27 k	1/2 w		5%
R288	302-823	82 k	1/2 w		
R289	302-105	1 meg	1/2 w		
R290A	*312-640	140 k	1/2 w		1%
R290B		280 k	1/2 w		1%
R290C		700 k	1/2 w		1%
R290D	*312-641	1.4 meg	1/2 w		1%
R290E		2.8 meg	1/2 w		1%
R290F		7 meg	1/2 w		1%
R290W	302-105	1 meg	1/2 w		
R290X	302-104	100 k	1/2 w		
R290Y	301-392	3.9 k	1/2 w		5%
R290Z†	311-391	150 k		Var	VARIABLE
R292	316-101	100 Ω	1/4 w		
R293	304-473	47 k	1 w		
R294	304-473	47 k	1 w		
R295	316-101	100 Ω	1/4 w		
R296	316-101	100 Ω	1/4 w		
R299	323-356	49.9 k	1/2 w	Prec	1%
R301	316-471	470 Ω	1/4 w		
R302	316-153	15 k	1/4 w		
R303	306-273	27 k	2 w		
R305	316-152	1.5 k	1/4 w		
R310	301-272	2.7 k	1/2 w		5%
R311	302-104	100 k	1/2 w		
R312	316-101	100 Ω	1/4 w		
R314	316-101	100 Ω	1/4 w		
R316	302-104	100 k	1/2 w		
R321	306-683	68 k	2 w		

†Furnished as a unit with SW290Z.

Parts List—Type 544

Resistors (Cont'd)

Ckt. No.	Tektronix Part No.		Description		S/N Range
R324	303-163	16 k	1 w		
R325	311-011	5 k		Var	5% SWEEP LENGTH
R326	305-393	39 k	2 w		5%
R328	302-102	1 k	1/2 w		
R329	302-562	5.6 k	1/2 w		
R330A	301-155	1.5 meg	1/2 w		5%
R330C	301-156	15 meg	1/2 w		5%
R334	323-373	75 k	1/2 w	Prec	1%
R335	323-273	6.81 k	1/2 w	Prec	1%
R337	323-481	1 meg	1/2 w	Prec	1%
R338	309-439	5.9 meg	1/2 w	Prec	1%
R339	316-101	100 Ω	1/4 w		
R341	301-334	330 k	1/2 w		5%
R342	301-274	270 k	1/2 w		5%
R343	301-683	68 k	1/2 w		5%
R344	316-101	100 Ω	1/4 w		
R345	323-302	13.7 k	1/2 w	Prec	1%
R346	323-385	100 k	1/2 w	Prec	1%
R347	323-402	150 k	1/2 w	Prec	1%
R348	316-101	100 Ω	1/4 w		
R349	302-122	1.2 k	1/2 w		
R361	323-243	3.32 k	1/2 w	Prec	1%
R362	308-268	22 k	5 w	WW	1%
R363	324-339	33.2 k	1 w	Prec	1%
R364	301-303	30 k	1/2 w		5%
R365	301-274	270 k	1/2 w		5%
R366	316-102	1 k	1/4 w		
R367	316-182	1.8 k	1/4 w		
R368	316-336	33 meg	1/4 w		
R369	316-182	1.8 k	1/4 w		
R370	301-472	4.7 k	1/2 w		5%
R371	302-472	4.7 k	1/2 w		
R372	302-274	270 k	1/2 w		
R373	316-470	47 Ω	1/4 w		
R374	323-353	46.4 k	1/2 w	Prec	1%
R375	323-330	26.7 k	1/2 w	Prec	1%
R376	323-356	49.9 k	1/2 w	Prec	1%
R380	302-0473-00	47 k	1/2 w		
R381	316-470	47 Ω	1/4 w		
R382	316-101	100 Ω	1/4 w		
R383	302-104	100 k	1/2 w		
R384	316-820	82 Ω	1/4 w		
R390	323-373	75 k	1/2 w	Prec	1%
R391	316-470	47 Ω	1/4 w		
R392	316-101	100 Ω	1/4 w		
R393	302-472	4.7 k	1/2 w		

X310-up

## Resistors (Cont'd)

Ckt. No.	Tektronix Part No.		Description		S/N Range
R394	316-101	100 $\Omega$	$\frac{1}{4}$ w		
R397	307-106	4.7 $\Omega$	$\frac{1}{4}$ w		5%
R398	316-101	100 $\Omega$	$\frac{1}{4}$ w		
R399	316-101	100 $\Omega$	$\frac{1}{4}$ w		
R501	302-470	47 $\Omega$	$\frac{1}{2}$ w		
R502C	323-614	990 k	$\frac{1}{2}$ w		Prec 1%
R502D	322-605	10.1 k	$\frac{1}{4}$ w		Prec 1%
R503C	323-611	900 k	$\frac{1}{2}$ w		Prec 1%
R503D	323-610	111 k	$\frac{1}{2}$ w		Prec 1%
R507	323-481	1 meg	$\frac{1}{2}$ w		Prec 1%
R508	316-102	1 k	$\frac{1}{4}$ w		
R509	306-333	33 k	2 w		
R510	311-060	1 k		Var	EXT GAIN
R511	Use 311-0571-00	15 k		Var	VAR 10-1
R512	306-333	33 k	2 w		
R514	316-101	100 $\Omega$	$\frac{1}{4}$ w		
R516	302-332	3.3 k	$\frac{1}{2}$ w		
R517	302-224	220 k	$\frac{1}{2}$ w		
R519	311-026	100 k		Var	EXT HORIZ DC BAL
R520	302-154	150 k	$\frac{1}{2}$ w		
R522	305-183	18 k	2 w		5%
R524	323-356	49.9 k	$\frac{1}{2}$ w		Prec 1%
R525	301-565	5.6 meg	$\frac{1}{2}$ w		5%
R526	302-101	100 $\Omega$	$\frac{1}{2}$ w		
R527	301-204	200 k	$\frac{1}{2}$ w		5%
R530A	311-431	50 k		Var	HORIZ POSITION VERNIER
R530B		50 k			
R531	323-369	68.1 k	$\frac{1}{2}$ w		Prec 1%
R532	301-394	390 k	$\frac{1}{2}$ w		5%
R533	323-452	499 k	$\frac{1}{2}$ w		Prec 1%
R534	304-123	12 k	1 w		
R535	316-390	39 $\Omega$	$\frac{1}{4}$ w		
R538	302-123	12 k	$\frac{1}{2}$ w		
R539	303-753	75 k	1 w		5%
R540	304-822	8.2 k	1 w		
R542	301-303	30 k	$\frac{1}{2}$ w		5%
R543	306-393	39 k	2 w		
R544	311-172	2.5 k		Var	X10 CAL
R545	323-284	8.87 k	$\frac{1}{2}$ w		Prec 1%
R547	302-104	100 k	$\frac{1}{2}$ w		
R553	323-295	11.5 k	$\frac{1}{2}$ w		Prec 1%
R554	308-211	12 k	5 w		WW 5%
R556	323-252	4.12 k	$\frac{1}{2}$ w		Prec 1%
R557C	323-663	4.225 k	$\frac{1}{2}$ w		Prec 1%
R557E	323-664	1.025 k	$\frac{1}{2}$ w		Prec 1%
R557F	301-182	1.8 k	$\frac{1}{2}$ w		5%
R557G	323-158	432 $\Omega$	$\frac{1}{2}$ w		Prec 1%

**Parts List—Type 544**

**Resistors (Cont'd)**

Ckt. No.	Tektronix Part No.		Description		S/N Range
R557H	301-122	1.2 k	1/2 w		5%
R557J	301-361	360 Ω	1/2 w		5%
R557K	323-122	182 Ω	1/2 w	Prec	1%
R557L	301-750	75 Ω	1/2 w		5%
R557M	323-665	44.3 Ω	1/2 w	Prec	1%
R558	302-104	100 k	1/2 w		
R561	302-104	100 k	1/2 w		
R563	323-281	8.25 k	1/2 w	Prec	1%
R564	308-211	12 k	5 w	WW	5%
R565	311-324	50 Ω		Var	X100 CAL
R566	311-066	500 Ω		Var	X1 CAL
R567	315-201	200 Ω	1/4 w		5%
R568	302-473	47 k	1/2 w		
R569	311-026	100 k		Var	SWP/MAG REGIS
R570	316-470	47 Ω	1/4 w		
R571	308-266	5 k	5 w	WW	5%
R572	*310-600	18 k/4.5 k	7 w	WW	
R573	316-470	47 Ω	1/4 w		
R574	316-470	47 Ω	1/4 w		
R576	*310-601	30 k	8 w	WW	1%
R577	302-154	150 k	1/2 w		
R578	316-103	10 k	1/4 w		
R579	302-394	390 k	1/2 w		
R580	316-470	47 Ω	1/4 w		
R581	302-155	1.5 meg	1/2 w		
R582	*310-611	18 k/3.7 k/800 Ω	6 w	WW	
R583	316-470	47 Ω	1/4 w		
R584	316-470	47 Ω	1/4 w		
R585	306-224	220 k	2 w		
R586	*310-601	30 k	8 w	WW	1%
R587	302-154	150 k	1/2 w		
R588	316-103	10 k	1/4 w		
R589	302-394	390 k	1/2 w		
R591	302-155	1.5 meg	1/2 w		
R592	302-102	1 k	1/2 w		
R594	302-104	100 k	1/2 w		
R595	302-563	56 k	1/2 w		
R597	316-470	47 Ω	1/4 w		
R598	304-103	10 k	1 w		
R599	302-473	47 k	1/2 w		
R601	308-229	4 k	5 w	WW	5%
R603	308-269	22 Ω	3 w	WW	5%
R605	311-377	25 Ω		Var	SCALE ILLUM
R608	302-333	33 k	1/2 w		
R610	302-104	100 k	1/2 w		

## Resistors (Cont'd)

Ckt. No.	Tektronix Part No.		Description			S/N Range
R615	324-369	68.1 k	1 w		Prec	1%
R616	311-015	10 k		Var		—150 VOLTS
R617	324-356	49.9 k	1 w		Prec	1%
R618	302-104	100 k	1/2 w			
R621	302-102	1 k	1/2 w			
R623	302-474	470 k	1/2 w			
R625	302-104	100 k	1/2 w			
R628	302-275	2.7 meg	1/2 w			
R629	302-275	2.7 meg	1/2 w			
R631	302-102	1 k	1/2 w			
R632	316-470	47 $\Omega$	1/4 w			
R634	302-105	1 meg	1/2 w			
R635	304-153	15 k	1 w			
R636	304-153	15 k	1 w			
R637	302-684	680 k	1/2 w			
R638	302-273	27 k	1/2 w			
R639	302-683	68 k	1/2 w			
R640	306-100	10 $\Omega$	2 w			
R641	306-100	10 $\Omega$	2 w			
R644	302-102	1 k	1/2 w			
R645	316-470	47 $\Omega$	1/4 w			
R646	308-065	2 k	25 w		WW	5%
R647	308-064	2.25 k	20 w		WW	5%
R650	324-443	402 k	1 w		Prec	1%
R651	324-458	576 k	1 w		Prec	1%
R663	302-105	1 meg	1/2 w			101-289
R663	301-0185-00	1.8 meg	1/2 w			290-up
R664	304-333	33 k	1 w			
R665	301-0225-00	2.2 meg	1/2 w			5% X290-up
R666	301-0226-00	22 meg	1/2 w			5% X290-up
R667	302-334	330 k	1/2 w			101-289
R667	301-0304-00	300 k	1/2 w			5% 290-up
R668	302-563	56 k	1/2 w			
R669	302-393	39 k	1/2 w			
R670A	306-100	10 $\Omega$	2 w			
R670B	306-100	10 $\Omega$	2 w			
R671	308-155	800 $\Omega$	25 w		WW	5%
R673	308-147	750 $\Omega$	25 w		WW	5%
R674	302-102	1 k	1/2 w			
R675	303-470	47	1 w			5%
R676	303-470	47	1 w			5%
R677	308-065	2 k	25 w		WW	5%
R680	324-443	402 k	1 w		Prec	1%
R681	324-601	264 k	1 w		Prec	1%
R682	302-124	120 k	1/2 w			
R683	302-102	1 k	1/2 w			
R685	304-823	82 k	1 w			
R686	302-184	180 k	1/2 w			
R688	302-155	1.5 meg	1/2 w			

Parts List—Type 544

Resistors (Cont'd)

Ckt. No.	Tektronix Part No.		Description		S/N Range
R689	302-225	2.2 meg	1/2 w		
R693	302-155	1.5 meg	1/2 w		
R694	302-473	47 k	1/2 w		
R697	302-824	820 k	1/2 w		
R698	302-274	270 k	1/2 w		
R699	302-473	47 k	1/2 w		
R700	306-100	10 Ω	2 w		
R701	306-100	10 Ω	2 w		
R703	303-470	47 Ω	1 w		5%
R704	302-102	1 k	1/2 w		
R705	303-470	47 Ω	1 w		5%
R706	308-065	2 k	25 w	WW	5%
R707	308-190	1.8 k	25 w	WW	5%
R710	324-467	715 k	1 w	Prec	1%
R711	324-604	303 k	1 w	Prec	1%
R712	302-154	150 k	1/2 w		
R723	302-105	1 meg	1/2 w		
R727	302-105	1 meg	1/2 w		
R728	302-684	680 k	1/2 w		
R729	302-224	220 k	1/2 w		
R730	302-100	10 Ω	1/2 w		
R731	306-823	82 k	2 w		
R734	316-470	47 Ω	1/4 w		
R737	308-034	6 k	20 w	WW	5%
R741	302-104	100 k	1/2 w		
R743	307-103	2.7 Ω	1/4 w		5%
R744	307-103	2.7 Ω	1/4 w		5%
R757	302-154	150 k	1/2 w		
R758	315-823	82 k	1/4 w		5%
R759	315-203	20 k	1/4 w		5%
R760	316-470	47 Ω	1/4 w		
R761	315-472	4.7 k	1/4 w		5%
R762	301-683	68 k	1/2 w		5%
R763	302-185	1.8 meg	1/2 w		
R764	302-105	1 meg	1/2 w		
R765	302-474	470 k	1/2 w		
R766	316-470	47 Ω	1/4 w		
R767	304-122	1.2 k	1 w		
R768	308-286	8.2 k	3 w	WW	5%
R769	316-101	100 Ω	1/4 w		
R771	323-097	100 Ω	1/2 w	Prec	1%
R773	323-097	100 Ω	1/2 w	Prec	1%
R774	324-097	100 Ω	1 w	Prec	1%
R775	323-097	100 Ω	1/2 w	Prec	1%
R777	307-103	2.7 Ω	1/4 w		5%

## Resistors (Cont'd)

Ckt. No.	Tektronix Part No.	Description			S/N Range	
R778†	311-407	2 x 10 Ω		Var	WW	TRACE ROTATION
R802	306-271	270 Ω	2 w			
R803	306-563	56 k	2 w			
R806	302-104	100 k	1/2 w			
R807	301-432	4.3 k	1/2 w			5%
R814	302-474	470 k	1/2 w			
R820	302-333	33 k	1/2 w			
R821	301-225	2.2 meg	1/2 w			5%
R822	302-333	33 k	1/2 w			
R824	305-755	7.5 meg	2 w			5%
R825	305-755	7.5 meg	2 w			5%
R826	311-450	1 meg		Var		INTENSITY
R827	302-333	33 k	1/2 w			
R828	302-223	22 k	1/2 w			
R830	302-335	3.3 meg	1/2 w			
R831	306-183	18 k	2 w			
R832	302-101	100 Ω	1/2 w			
R836	316-105	1 meg	1/4 w			
R840	311-034	500 k		Var		HIGH VOLTAGE
R841	303-225	2.2 meg	1 w			5%
R842	303-335	3.3 meg	1 w			5%
R843	303-275	2.7 meg	1 w			5%
R845	303-335	3.3 meg	1 w			5%
R846	311-313	5 meg		Var		FOCUS
R847	302-474	470 k	1/2 w			
R853	302-103	10 k	1/2 w			
R857	302-273	27 k	1/2 w			
R858	302-105	1 meg	1/2 w			
R859	302-471	470 Ω	1/2 w			
R861	311-026	100 k		Var		GEOMETRY
R862	301-823	82 k	1/2 w			5% 101-209
R862	323-395	127 k	1/2 w		Prec	1% 210-up
R863	301-473	47 k	1/2 w			5% 101-209
R863	323-356	49.9 k	1/2 w		Prec	1% 210-up
R864†	311-407	50 k		Var		ASTIGMATISM
R931	302-154	150 k	1/2 w			
R932	301-394	390 k	1/2 w			5%
R934	301-475	4.7 meg	1/2 w			5%
R935	302-103	10 k	1/2 w			
R936	302-102	1 k	1/2 w			
R938	302-102	1 k	1/2 w			
R939	302-221	220 Ω	1/2 w			

† R778 and R864 furnished as a unit.

## Resistors (Cont'd)

Ckt. No.	Tektronix Part No.		Description			S/N Range
R941	302-221	220 $\Omega$	$\frac{1}{2}$ w			
R943	311-141	2 k		Var	WW	CAL AMPL
R944	302-100	10 $\Omega$	$\frac{1}{2}$ w			
R945	308-268	22 k	5 w		WW	5%
R948	315-0682-00	6.8 k	$\frac{1}{4}$ w			5%
R949	302-274	270 k	$\frac{1}{2}$ w			X470-up
R950	323-289	10 k	$\frac{1}{2}$ w		Prec	1%
R950	232-0709-01	10.048 k	$\frac{1}{2}$ w		Prec	$\frac{1}{2}$ %
R951	323-635	6.667 k	$\frac{1}{2}$ w		Prec	1%
R951	323-0708-01	6.628 k	$\frac{1}{2}$ w		Prec	$\frac{1}{2}$ %
R952	323-634	1.789 k	$\frac{1}{2}$ w		Prec	1%
R952	323-0707-01	1.782 k	$\frac{1}{2}$ w		Prec	$\frac{1}{2}$ %
R953	323-633	801 $\Omega$	$\frac{1}{2}$ w		Prec	1%
R953	323-0706-01	800 $\Omega$	$\frac{1}{2}$ w		Prec	$\frac{1}{2}$ %
R954	323-632	452 $\Omega$	$\frac{1}{2}$ w		Prec	1%
R954	323-0705-01	452 $\Omega$	$\frac{1}{2}$ w		Prec	$\frac{1}{2}$ %
R955	323-631	146.1 $\Omega$	$\frac{1}{2}$ w		Prec	1%
R955	323-0704-01	146 $\Omega$	$\frac{1}{2}$ w		Prec	$\frac{1}{2}$ %
R956	323-630	72.4 $\Omega$	$\frac{1}{2}$ w		Prec	1%
R956	323-0703-01	72.4 $\Omega$	$\frac{1}{2}$ w		Prec	$\frac{1}{2}$ %
R957	323-629	43.1 $\Omega$	$\frac{1}{2}$ w		Prec	1%
R957	323-0702-01	43.1 $\Omega$	$\frac{1}{2}$ w		Prec	$\frac{1}{2}$ %
R958	323-628	28.6 $\Omega$	$\frac{1}{2}$ w		Prec	1%
R958	323-0701-01	28.6 $\Omega$	$\frac{1}{2}$ w		Prec	$\frac{1}{2}$ %
R960	323-636	50 k	$\frac{1}{2}$ w		Prec	1%
R962	323-627	21.4 $\Omega$	$\frac{1}{2}$ w		Prec	1%
R962	323-0700-01	21.4 $\Omega$	$\frac{1}{2}$ w		Prec	$\frac{1}{2}$ %
R964	323-638	50 k	$\frac{1}{2}$ w		Prec	$\frac{1}{4}$ %
R965	323-637	50 $\Omega$	$\frac{1}{2}$ w		Prec	$\frac{1}{4}$ %
R969	308-242	0.25 $\Omega$	5 w		WW	5%
R1000	316-820	82 $\Omega$	$\frac{1}{4}$ w			
R1001	315-220	22 $\Omega$	$\frac{1}{4}$ w			5%
R1002	301-101	100 $\Omega$	$\frac{1}{2}$ w			5%
R1003	305-682	6.8 k	2 w			5%
R1004	311-086	2.5 k		Var		VERT DC BAL
R1011	315-220	22 $\Omega$	$\frac{1}{4}$ w			5%
R1013	305-682	6.8 k	2 w			5%
R1014	301-131	130 $\Omega$	$\frac{1}{2}$ w			5%
R1015	315-131	130 $\Omega$	$\frac{1}{2}$ w			5%
R1016	315-300	30 $\Omega$	$\frac{1}{4}$ w			5%
R1017	311-258	100 $\Omega$		Var		VERT GAIN
R1018	305-273	27 k	2 w			5%
R1019	308-002	1.5 k	5 w		WW	5%
R1020	316-331	330 $\Omega$	$\frac{1}{4}$ w			5%
R1024	301-131	130 $\Omega$	$\frac{1}{2}$ w			5%
R1025	315-131	130 $\Omega$	$\frac{1}{4}$ w			5%
R1026	315-300	30 $\Omega$	$\frac{1}{4}$ w			5%
R1027	315-121	120 $\Omega$	$\frac{1}{4}$ w			5%
R1027	315-471	470 $\Omega$	$\frac{1}{4}$ w			5%
R1031	315-512	5.1 k	$\frac{1}{4}$ w			5%
R1033	322-092	88.7 $\Omega$	$\frac{1}{4}$ w		Prec	1%
R1034	315-100	10 $\Omega$	$\frac{1}{4}$ w			5%
R1038	301-821	820 $\Omega$	$\frac{1}{2}$ w			5%



## Resistors (Cont'd)

Ckt. No.	Tektronix Part No.		Description		S/N Range
R1041	315-512	5.1 k	1/4 w		5%
R1042	322-092	88.7 $\Omega$	1/4 w	Prec	1%
R1048	301-821	820 $\Omega$	1/2 w		5%
R1051	321-117	162 $\Omega$	1/8 w	Prec	1%
R1061	321-117	162 $\Omega$	1/8 w	Prec	1%
R1069	315-361	360 $\Omega$	1/4 w		5%
R1071	315-360	36 $\Omega$	1/4 w		5%
R1072	323-105	121 $\Omega$	1/2 w	Prec	1%
R1073	301-331	330 $\Omega$	1/2 w		5%
R1074	321-073	56.2 $\Omega$	1/8 w	Prec	1%
R1076	311-442	250 $\Omega$		Var	
R1077	315-163	16 k	1/4 w		5%
R1082	323-105	121 $\Omega$	1/2 w	Prec	1%
R1083	301-331	330 $\Omega$	1/2 w		5%
R1084	321-073	56.2 $\Omega$	1/8 w	Prec	1%
R1087	304-122	1.2 k	1 w		
R1088	305-681	680 $\Omega$	2 w		5%
R1089	308-296	1.2 k	5 w	WW	5%
R1104	301-270	27 $\Omega$	1/2 w		5%
R1105	323-102	113 $\Omega$	1/2 w	Prec	1%
R1106	311-442	250 $\Omega$		Var	
R1108	*310-603	600 $\Omega$ /300 $\Omega$	3 w	WW	2%
R1109	305-0243-00	24 k	2 w		5%
R1113	315-100	10 $\Omega$	1/4 w		5%
R1114	*310-602	1 k	8 w	WW	1%
R1118	308-232	320 $\Omega$	5 w	WW	5%
R1124	301-270	27 $\Omega$	1/2 w		5%
R1126	321-204	1.3 k	1/8 w	Prec	1%
R1129	308-283	800 $\Omega$	10 w	WW	5%
R1132	315-100	10 $\Omega$	1/4 w		5%
R1134	*310-602	1 k	8 w	WW	1%
R1141	322-092	88.7 $\Omega$	1/4 w	Prec	1%
R1142	315-331	330 $\Omega$	1/4 w		5%
R1144	301-681	680 $\Omega$	1/2 w		5%
R1151	322-092	88.7 $\Omega$	1/4 w	Prec	1%
R1152	315-331	330 $\Omega$	1/4 w		5%
R1153	315-100	10 $\Omega$	1/4 w		5%
R1154	301-681	680 $\Omega$	1/2 w		5%
R1156	315-820	82 $\Omega$	1/4 w		5%
R1157	315-361	360 $\Omega$	1/4 w		5%
R1161	315-221	220 $\Omega$	1/4 w		5%
R1163	308-258	6 k	3 w	WW	5%
R1165	315-820	82 $\Omega$	1/4 w		5%
R1166	302-221	220 $\Omega$	1/2 w		
R1169	302-105	1 meg	1/2 w		
R1173	308-258	6 k	3 w	WW	5%
R1175	315-820	82 $\Omega$	1/4 w		5%
R1181	315-105	1 meg	1/4 w		5%
R1184	301-334	330 k	1/2 w		5%
R1187	301-334	330 k	1/2 w		5%
R1191	315-105	1 meg	1/4 w		5%
R1194	301-334	330 k	1/2 w		5%

X370-up

**Parts List—Type 544**

**Switches**

Ckt. No.	Tektronix Part No.	Description	S/N Range
	Unwired    Wired		
SW201	260-495	Lever	SOURCE COUPLING    } SLOPE            } TRIGGERING MODE            } PULL FOR X10 RANGE INCREASE
SW205	260-494	Lever	
SW210	260-542	Lever	
SW375	260-493	Lever	
SW215†	311-426		
SW290	260-530 *262-606	Rotary	TIME/CM
SW290Z††	311-391		
SW135	260-516	Push	RESET
SW369	260-496	Lever	SINGLE SWEEP
SW502	260-207 *262-609		EXTERNAL HORIZONTAL
SW530	260-576 *262-608	Rotary	HORIZONTAL DISPLAY
SW601	260-199	Toggle	POWER ON
SW673	260-516	Push	
SW858	260-209	Toggle	CRT CATHODE SELECTOR
SW950	260-536 Use *262-0731-00	Rotary	CALIBRATOR
SW1000	260-601	Slide	COMPENSATION
TK601	260-336	Thermal Cutout	150° F ±5° F

**Transformers**

T252	Use *120-0323-01	Toroid	2T Bifilar
T601	*120-307	L.V.	Power
T801	*120-308	H.V.	Power
T1030	*120-341	Toroid	3T Bifilar
T1104	276-541	Core, Ferrite	

**Electron Tubes**

V224	154-187	6DJ8
V291	154-040	12AU6
V293	154-187	6DJ8
V345	154-187	6DJ8
V393	154-187	6DJ8
V514	154-187	6DJ8
V574	154-187	6DJ8
V584	154-187	6DJ8
V589	154-146	6197
V609	154-291	OG3
V624	154-043	12AX7
V634	154-022	6AU6
V637	154-202	6CW5
V647	154-202	6CW5
V664	154-414	6BY8

†Furnished as a unit with R215.

††Furnished as a unit with R290Z.

## Electron Tubes (Cont'd)

Ckt. No.	Tektronix Part No.	Description	S/N Range
V677	154-056	6080	
V684	154-043	12AX7	
V694	154-022	6AU6	
V707	154-056	6080	
V724	154-022	6AU6	
V737	154-202	6CW5	
V764	154-187	6DJ8	
V800	154-021	6AU5	
V814	154-041	12AU7	
V822	154-051	5642	
V832	154-051	5642	
V842	154-051	5642	
V852	154-051	5642	
V859†	Use *154-0478-00	T5470-31-2 Crt Standard Phosphor	100-319
V859	*154-0478-00	T5470-31-2 Crt Standard Phosphor	320-up
V862	154-051	5642	
V935	154-041	12AU7	
V945	154-022	6AU6	
V1003	154-039	12AT7	
V1184	154-043	12AX7	

† S/N 100-319 add \*050-0246-00 kit.

## IMPORTANT

All circuit voltages were obtained with a 20,000  $\Omega$ /Volt VOM. All readings are in volts.

Waveforms were obtained using a Type 530-Series Oscilloscope with a Type L Plug-In Unit and 10X probe. An equivalent oscilloscope having a bandwidth of dc to 10 mc or better and equal sensitivity can be used instead.

Waveform dc levels with respect to ground are indicated at the right side of waveform; measured when test oscilloscope AC-DC switch was set to DC.

Waveforms were photographed with test oscilloscope AC-DC switch set to AC; vertical deflection factor and Time/Cm switch set to those settings indicated adjacent to waveforms. In most cases +Ext. AC triggering on the Type 544 1-kc AMPLITUDE CALIBRATOR signal was used. Exception: +Int. triggering mode is also used; this mode, if used, is indicated above the waveform.

## NOTE

Number of cycles displayed by waveform when calibrator signal was used as a trigger source depends mostly on the signal repetition rate. Though +Ext. triggering was used, a time difference of 1 msec can occur between waveforms because the test oscilloscope can trigger on a different cycle than the Type 544 and vice versa.

Voltage and waveform measurements may vary between instruments due to normal component tolerances.

Plug-in unit that was used in the Type 544 is a Type TU-7 Test Unit. Front-panel controls and other conditions that apply to all schematic diagrams are as follows:

Input Signal . . . . . None  
Position . . . . . Centered  
(Exception: See Vertical  
Amplifier schematic diagram)  
Test Function . . . . . Low Load

Any letter-series, 1-series plug-in unit or the TU-2 can be used in place of the Type TU-7 when troubleshooting the Type 544.

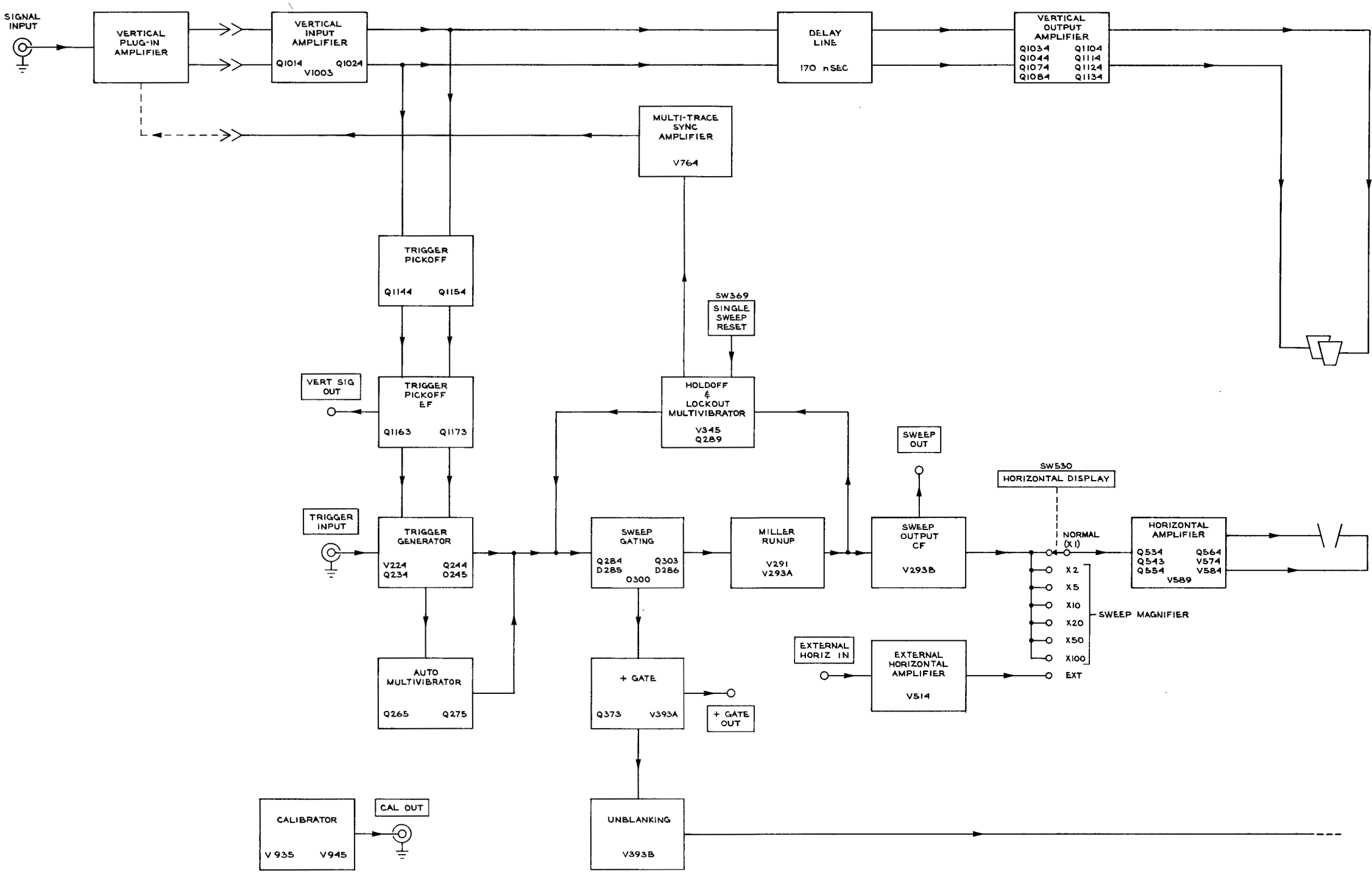

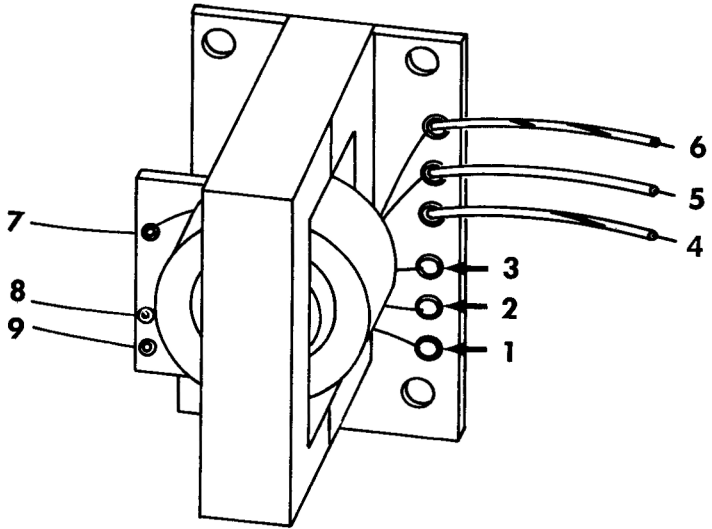

**T801 TRANSFORMER DETAILS**

**CRT CIRCUIT**

WAVEFORM AND DYNAMIC VOLTAGE READINGS were obtained under the following conditions:

INTENSITY ..... ccw

POWER ..... ON

\*: Voltage reading obtained with associated control set for normal operation. Voltage is dependent on position of the control.

Also see IMPORTANT note on Block Diagram.

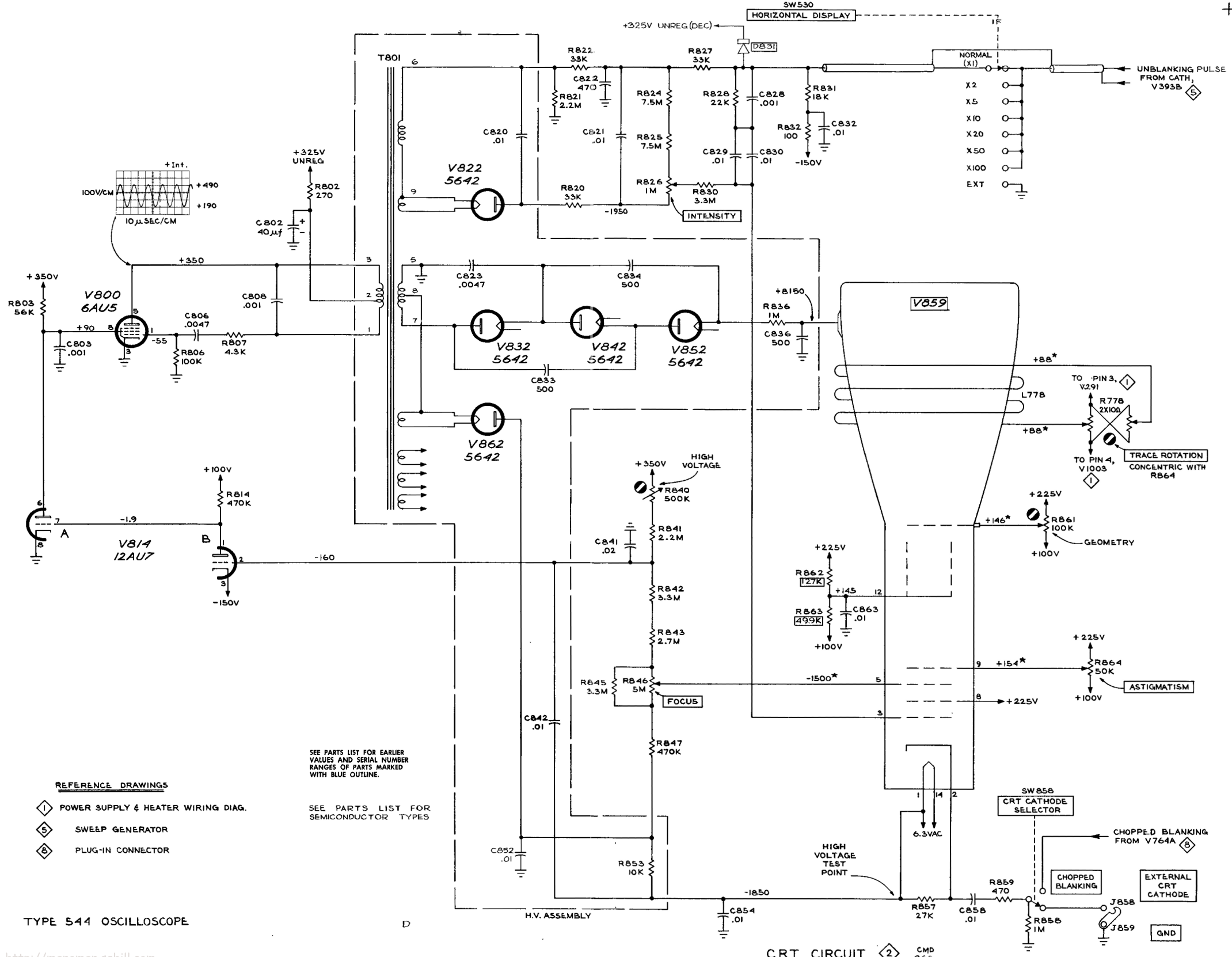

TYPE 544 OSCILLOSCOPE

- REFERENCE DRAWINGS**
- ① POWER SUPPLY & HEATER WIRING DIAG.
  - ② SWEEP GENERATOR
  - ③ PLUG-IN CONNECTOR

SEE PARTS LIST FOR EARLIER VALUES AND SERIAL NUMBER RANGES OF PARTS MARKED WITH BLUE OUTLINE.

SEE PARTS LIST FOR SEMICONDUCTOR TYPES

CRT CIRCUIT ②

CMP 865

## POWER SUPPLY

VOLTAGE READINGS WERE OBTAINED under the following conditions:

LINE VOLTAGE ..... 115 VAC (or Design Center)

INPUT SIGNAL ..... None

TRIGGER INPUT Signal ..... None

TRIGGERING LEVEL ..... ccw

TRIGGERING MODE ..... TRIG

TRIGGERING SOURCE ..... EXT

AMPLITUDE CALIBRATOR ..... OFF

POWER ..... ON

Also see IMPORTANT note on Block Diagram.



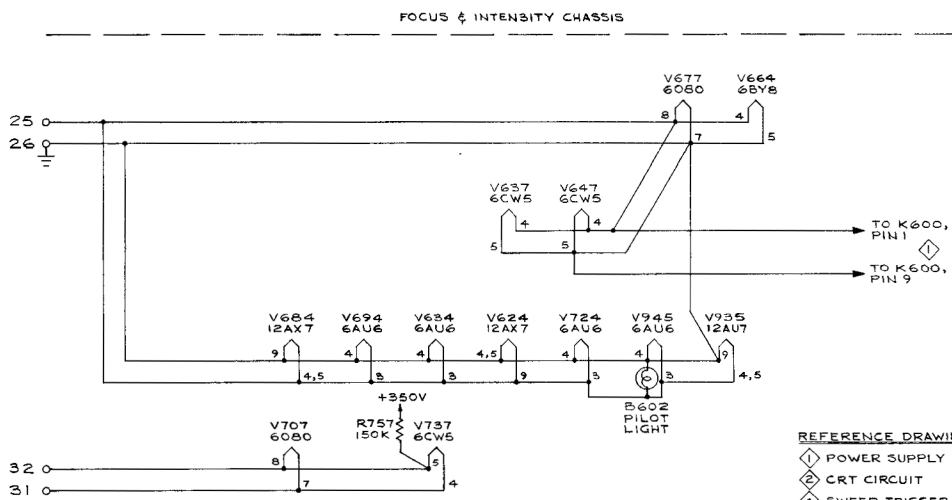
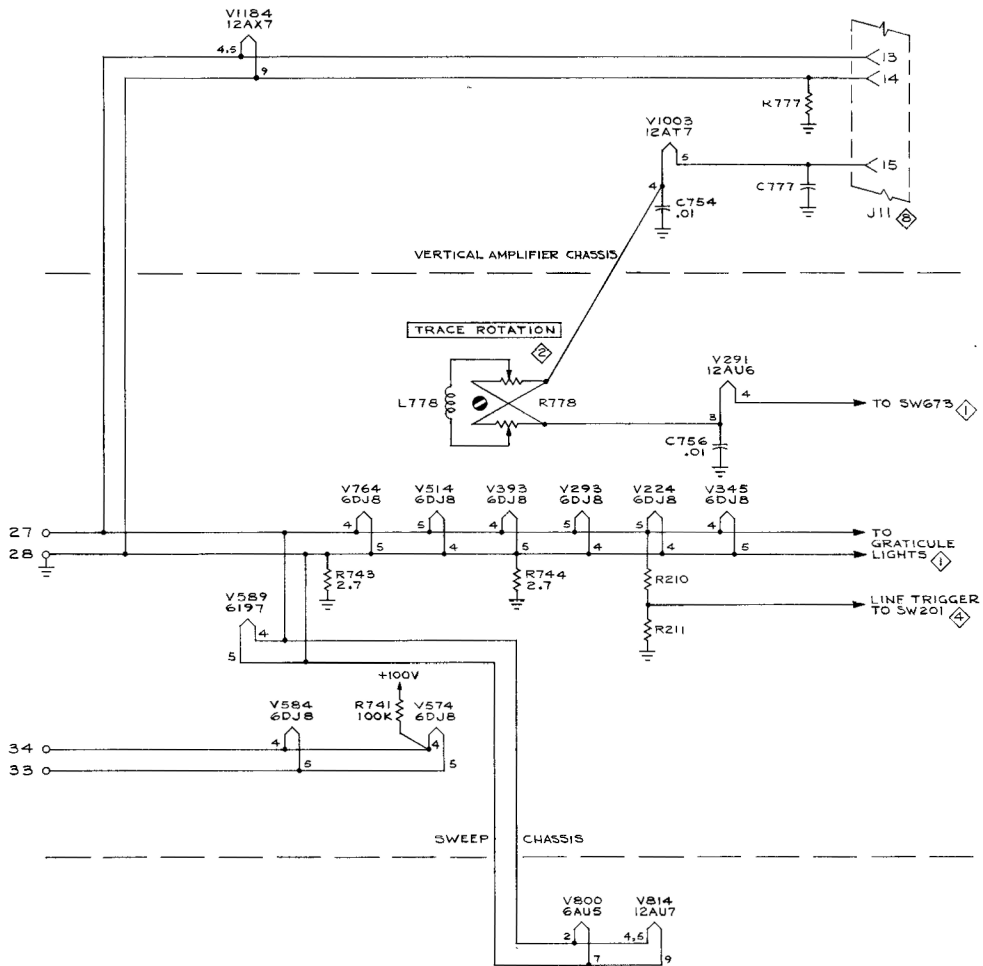

- REFERENCE DRAWINGS:**
- ① POWER SUPPLY
  - ② CRT CIRCUIT
  - ④ SWEEP TRIGGER
  - ⑤ PLUG-IN CONNECTOR

POWER SUPPLY CHASSIS

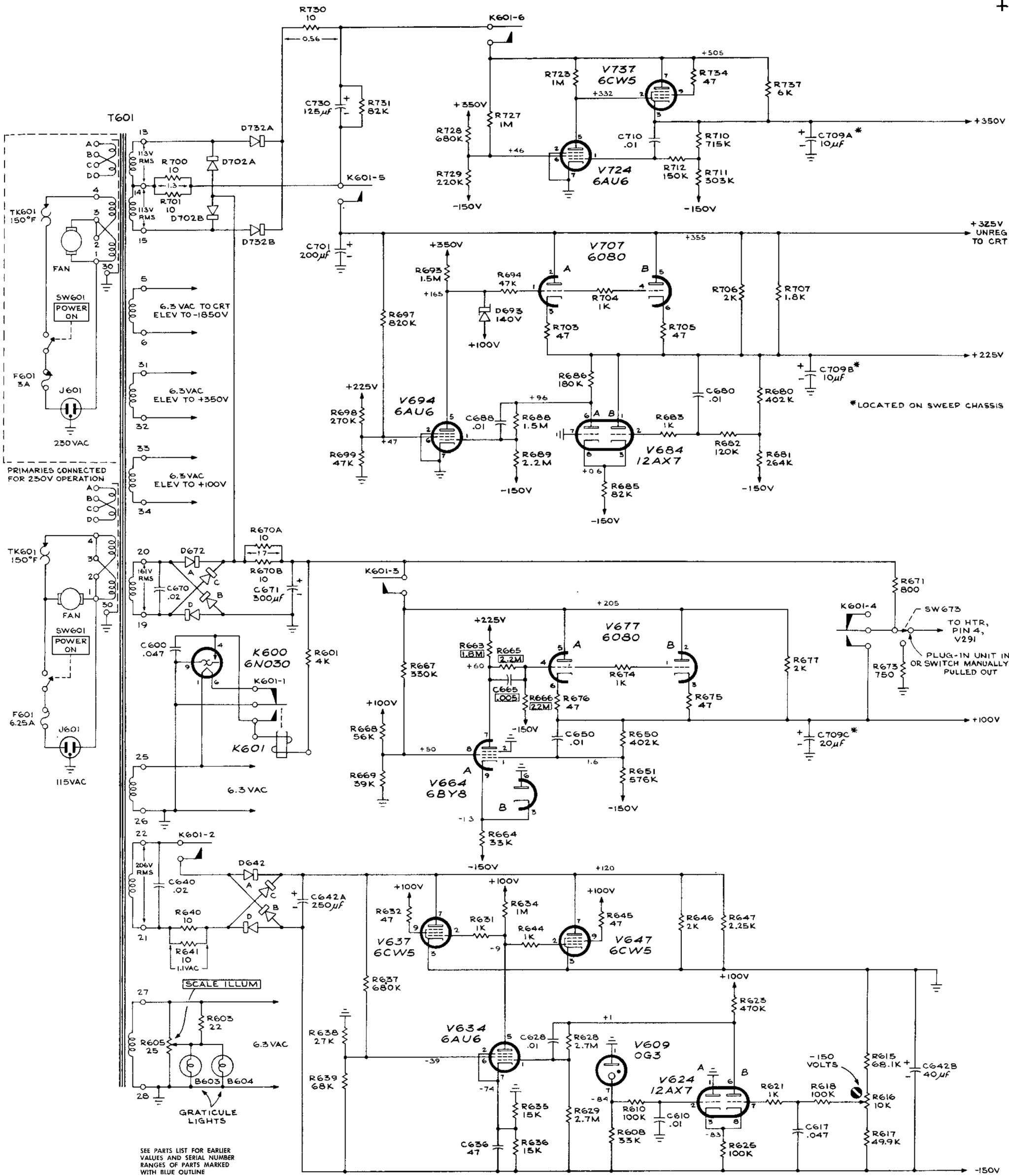

PRIMARIES CONNECTED FOR 230V OPERATION

SCALE ILLUM

GRATICULE LIGHTS

SEE PARTS LIST FOR EARLIER VALUES AND SERIAL NUMBER RANGES OF PARTS MARKED WITH BLUE OUTLINE

\* LOCATED ON SWEEP CHASSIS

TO HTR, PIN 4, V291  
PLUG-IN UNIT IN OR SWITCH MANUALLY PULLED OUT

## VERTICAL AMPLIFIER

QUIESCENT VOLTAGE READINGS were obtained under the following conditions:

Oscilloscope:

POWER ..... ON

Type TU-7:

INPUT SIGNAL ..... None

VERTICAL POSITION ..... Centered\*

TEST FUNCTION ..... COMMON MODE

\*If a letter-series or '1'-series plug-in unit is used, adjust the plug-in unit Vertical Position control to obtain zero volts reading between pins 1 and 3 of the interconnecting plug.

Also see IMPORTANT note on Block Diagram.

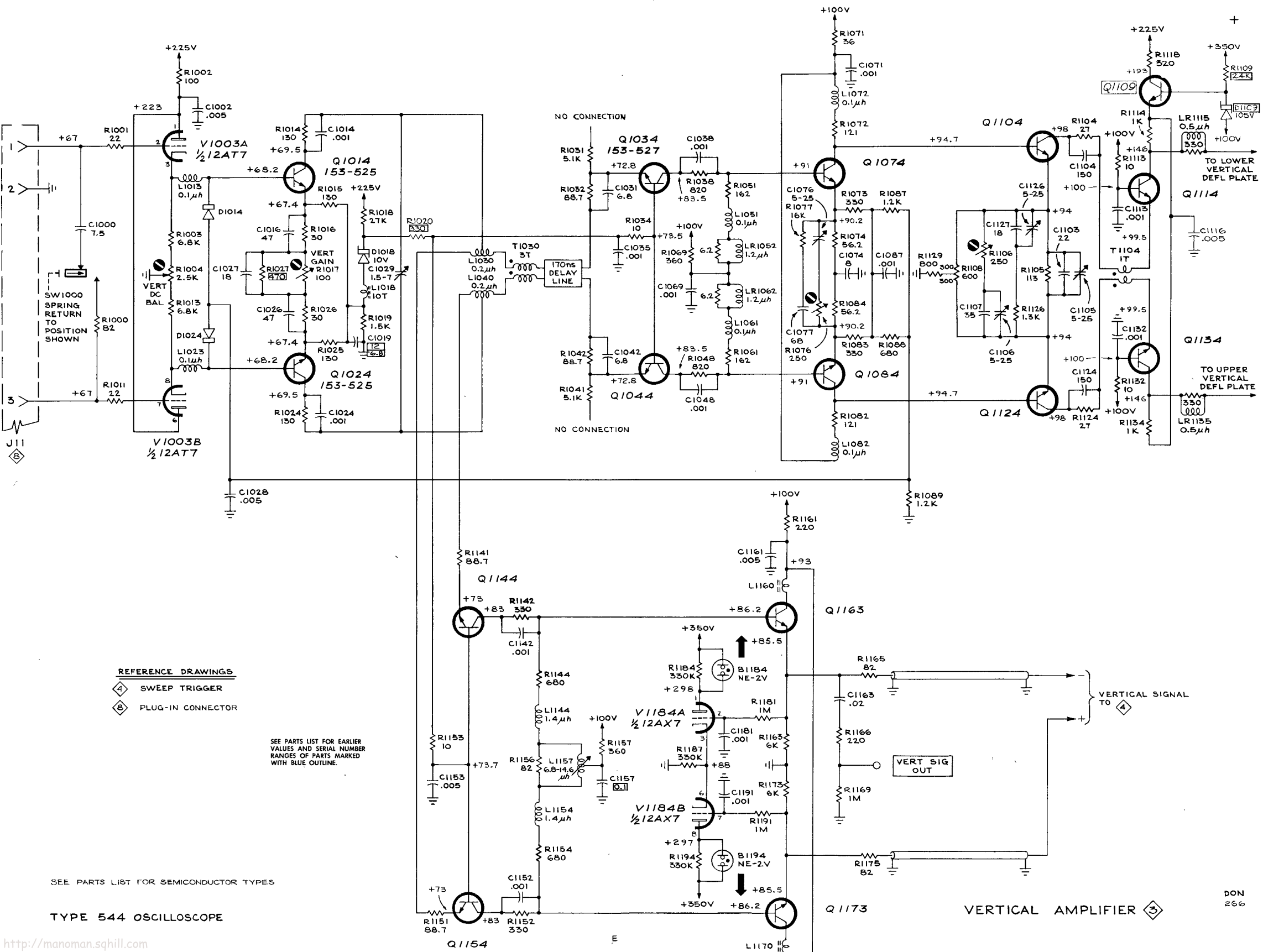

**REFERENCE DRAWINGS**

- ④ SWEEP TRIGGER
- ⑧ PLUG-IN CONNECTOR

SEE PARTS LIST FOR EARLIER VALUES AND SERIAL NUMBER RANGES OF PARTS MARKED WITH BLUE OUTLINE.

SEE PARTS LIST FOR SEMICONDUCTOR TYPES

TYPE 544 OSCILLOSCOPE

VERTICAL AMPLIFIER ③

DON 266

## SWEEP TRIGGER

WAVEFORMS AND VOLTAGE READINGS were obtained under the following conditions:

### TIME BASE

#### TRIGGERING:

MODE .....	TRIG
SLOPE .....	+
COUPLING .....	AC
SOURCE .....	EXT

HORIZONTAL DISPLAY ..... NORMAL

POWER ..... ON

### WAVEFORM Conditions —

TRIGGER INPUT Signal .....	10 Volts P-P Calibrator
TRIGGERING LEVEL .....	+45°; knob pushed in
TIME/CM .....	.1 mSEC
AMPLITUDE CALIBRATOR .....	10 Volts

### QUIESCENT VOLTAGE Conditions —

TRIGGER INPUT Signal .....	None
TRIGGERING LEVEL with knob pushed in:	
Upper Voltage Readings .....	ccw
Lower Voltage Readings .....	cw

Also see IMPORTANT note on Block Diagram.

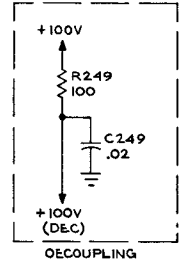
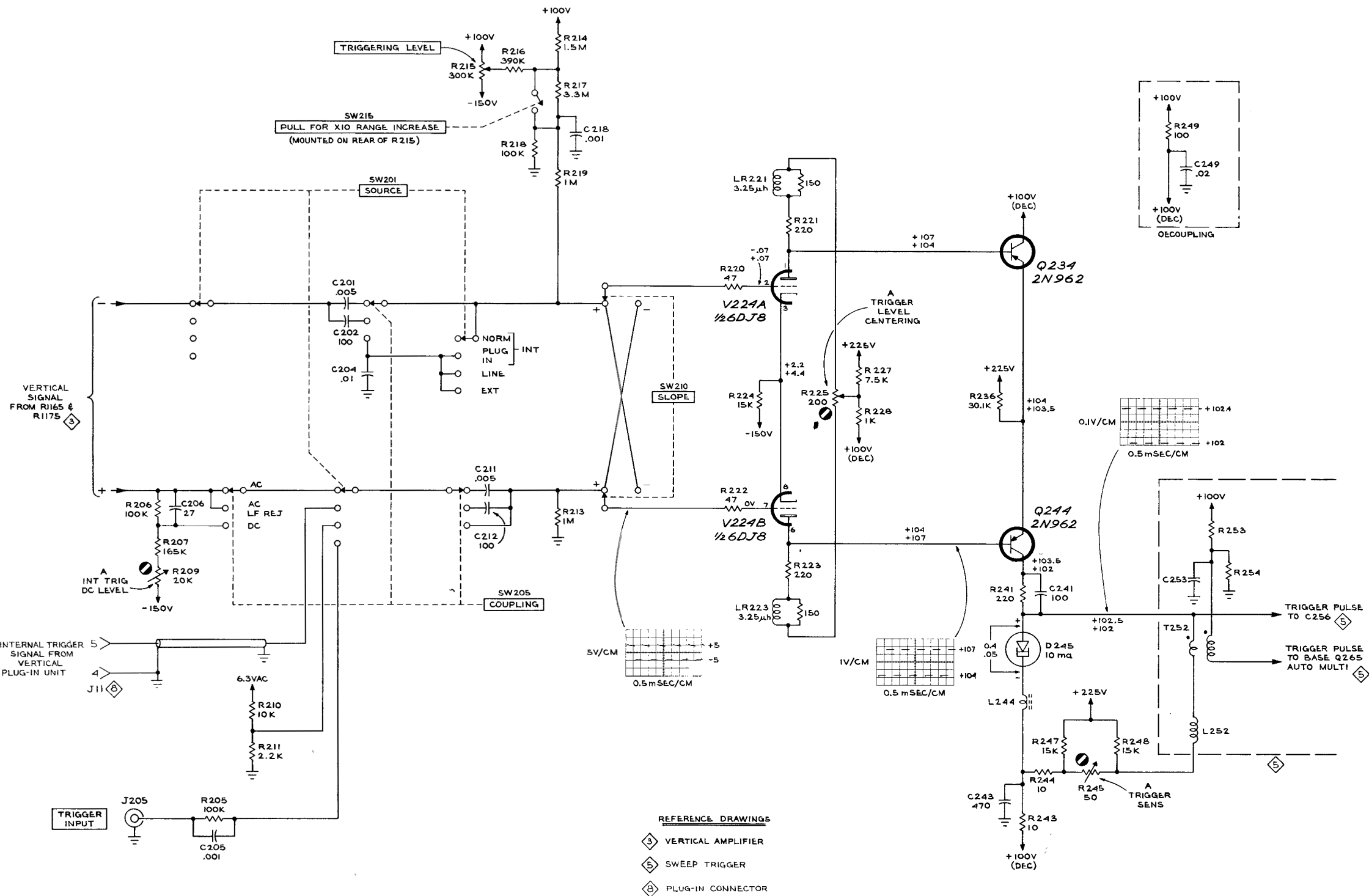

CMD 364

SWEEP TRIGGER (4)

## SWEEP GENERATOR

WAVEFORMS AND VOLTAGE READINGS were obtained under the following conditions:

### TIME BASE

TRIGGERING LEVEL .....	+45°; pushed in
TRIGGERING:	
SLOPE .....	+
COUPLING .....	AC
SOURCE .....	EXT
BRIGHTNESS .....	cw
TIME/CM .....	.1 mSEC
VARIABLE (TIME/CM) .....	CALIBRATED

HORIZONTAL DISPLAY ..... NORMAL

POWER ..... ON

### WAVEFORM CONDITIONS —

TRIGGER INPUT SIGNAL .....	10 Volts P-P Calibrator
TRIGGERING MODE .....	TRIG (AUTO for waveforms at collectors of Q65 and Q75).
AMPLITUDE CALIBRATOR .....	10 Volts

### QUIESCENT VOLTAGE CONDITIONS —

TRIGGER INPUT SIGNAL .....	None
TRIGGERING MODE .....	TRIG

Also see IMPORTANT note on Block Diagram.

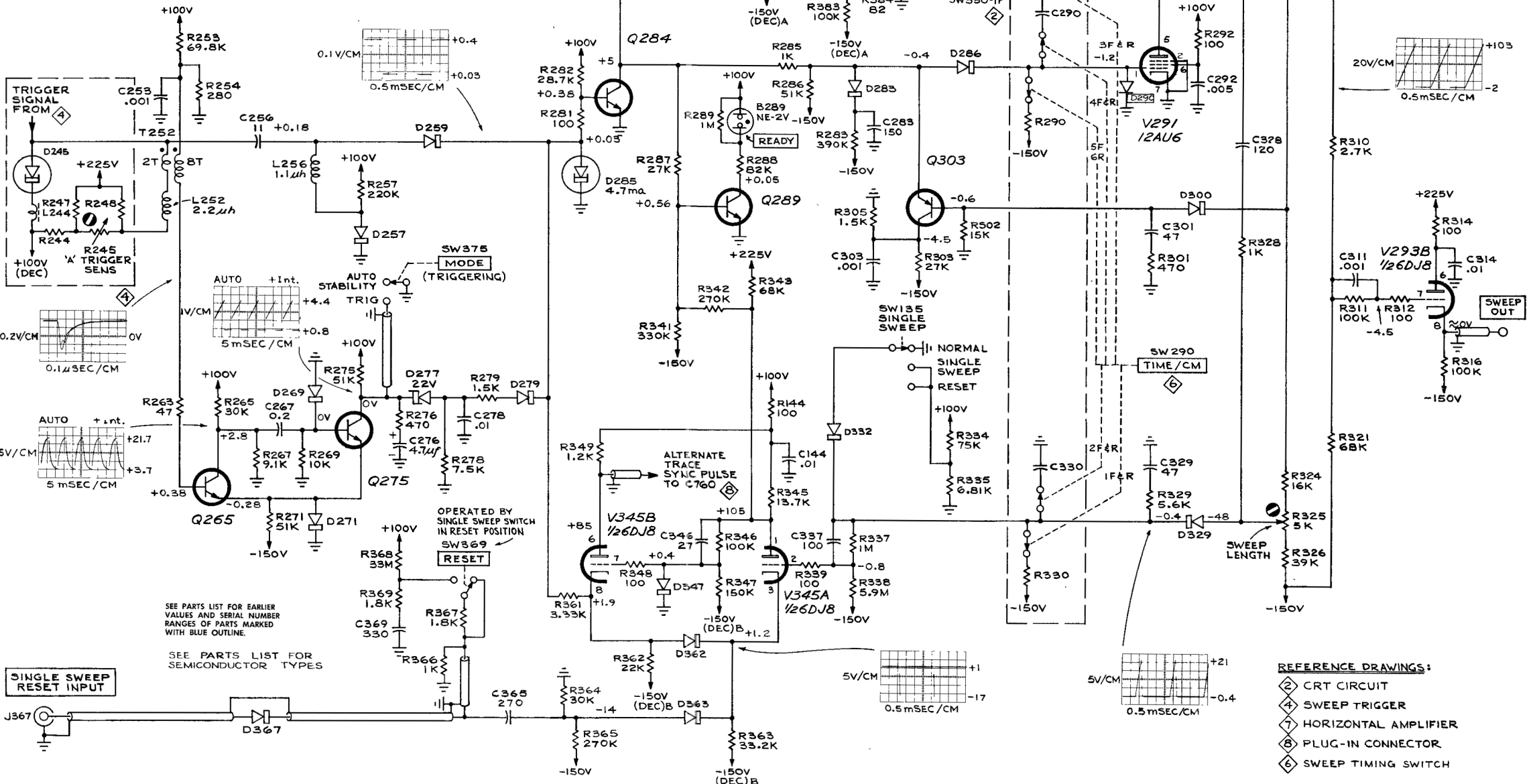
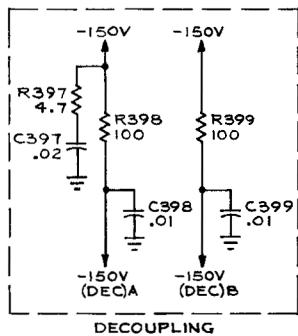



# HORIZONTAL AMPLIFIER

WAVEFORM AND VOLTAGE READINGS were obtained under the following conditions:

## TIME BASE

TRIGGERING LEVEL .....	+45°; pushed in
TRIGGERING:	
MODE .....	TRIG
SLOPE .....	+
COUPLING .....	AC
SOURCE .....	EXT
TIME/CM .....	.1 mSEC/CM
VARIABLE (TIME/CM) .....	CALIBRATED
SWEEP MAGNIFIER .....	X1
HORIZONTAL POSITION (VERNIER) ..	ccw

INTENSITY ..... Normal

## WAVEFORM CONDITIONS —

TRIGGER INPUT Signal .....	10 Volts P-P Calibrator
AMPLITUDE CALIBRATOR .....	10 Volts
HORIZONTAL DISPLAY .....	NORMAL
SWEEP MAGNIFIER .....	X1
HORIZONTAL POSITION .....	Centered

## QUIESCENT VOLTAGE CONDITIONS —

HORIZ INPUT Signal .....	None
HORIZONTAL DISPLAY .....	Ext
HORIZONTAL POSITION:	
Upper Voltage Readings .....	ccw
Lower Voltage Readings .....	cw

Also see IMPORTANT note on Block Diagram.

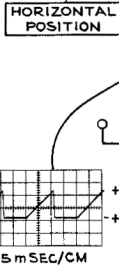
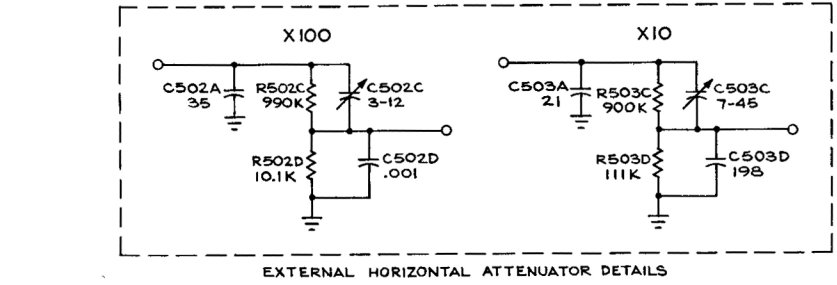
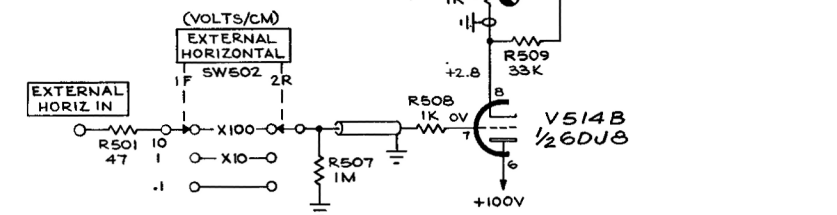
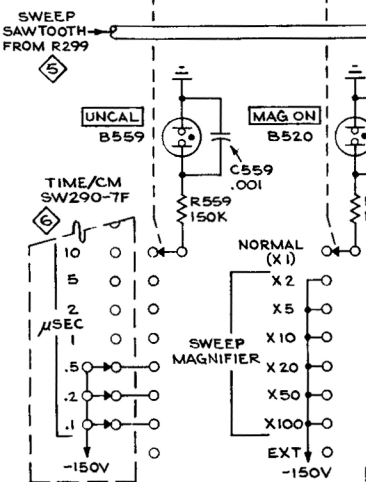
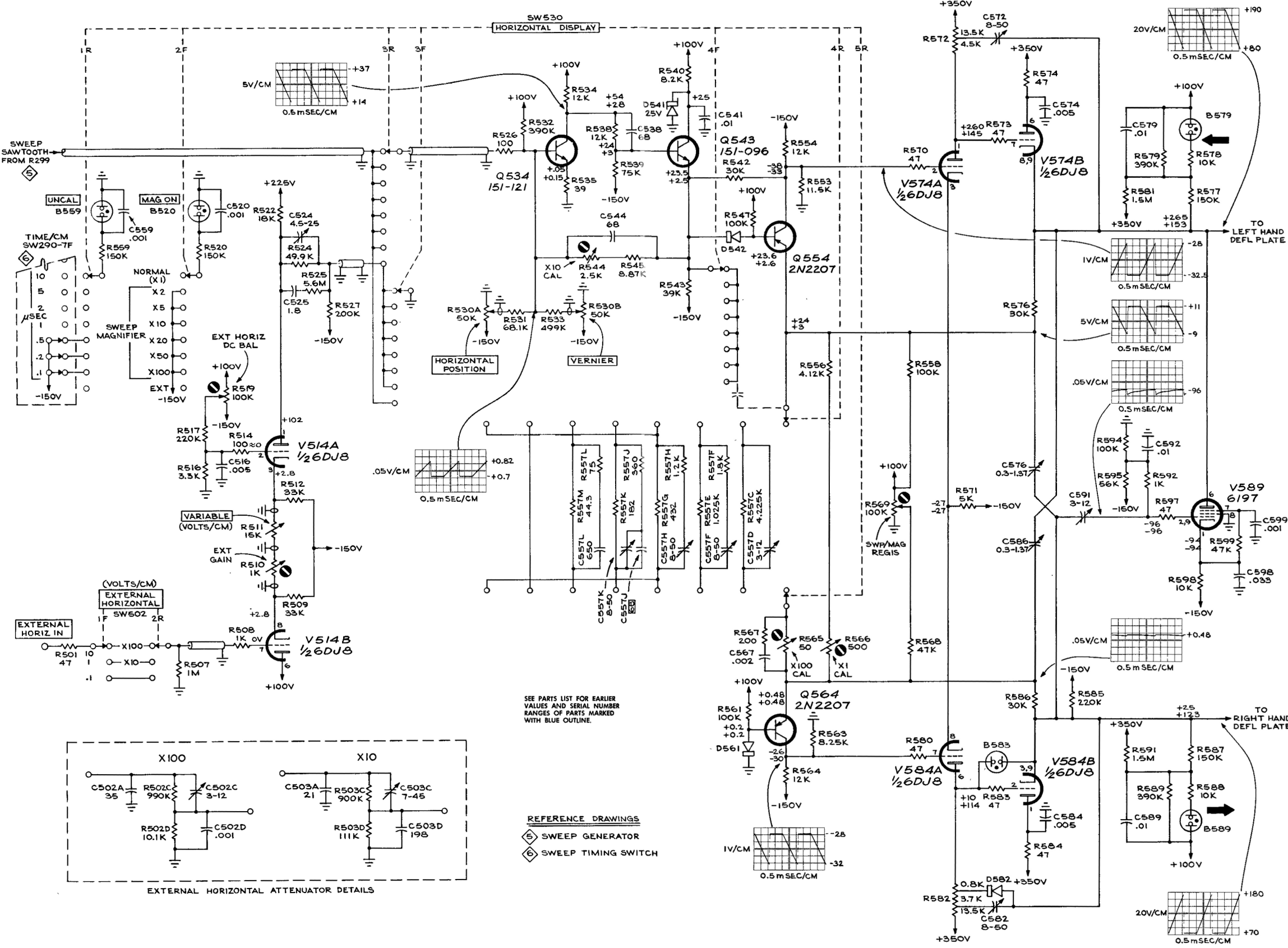

SEE PARTS LIST FOR EARLIER VALUES AND SERIAL NUMBER RANGES OF PARTS MARKED WITH BLUE OUTLINE.

- REFERENCE DRAWINGS**
- ⊖ SWEEP GENERATOR
  - ⊖ SWEEP TIMING SWITCH

## SYNC AMP.

WAVEFORM AND VOLTAGE READINGS were obtained under the following conditions:

HORIZONTAL DISPLAY ..... NORMAL

### TIME BASE

TRIGGER INPUT Signal ..... None  
TRIGGERING LEVEL ..... cw  
TRIGGERING SOURCE ..... EXT  
TIME/CM ..... 50  $\mu$ SEC  
VARIABLE ..... CALIBRATED

POWER ..... ON

### WAVEFORM CONDITIONS —

TRIGGERING MODE ..... AUTO

### QUIESCENT VOLTAGE CONDITIONS —

TRIGGERING MODE ..... TRIG

Also see IMPORTANT note on Block Diagram.

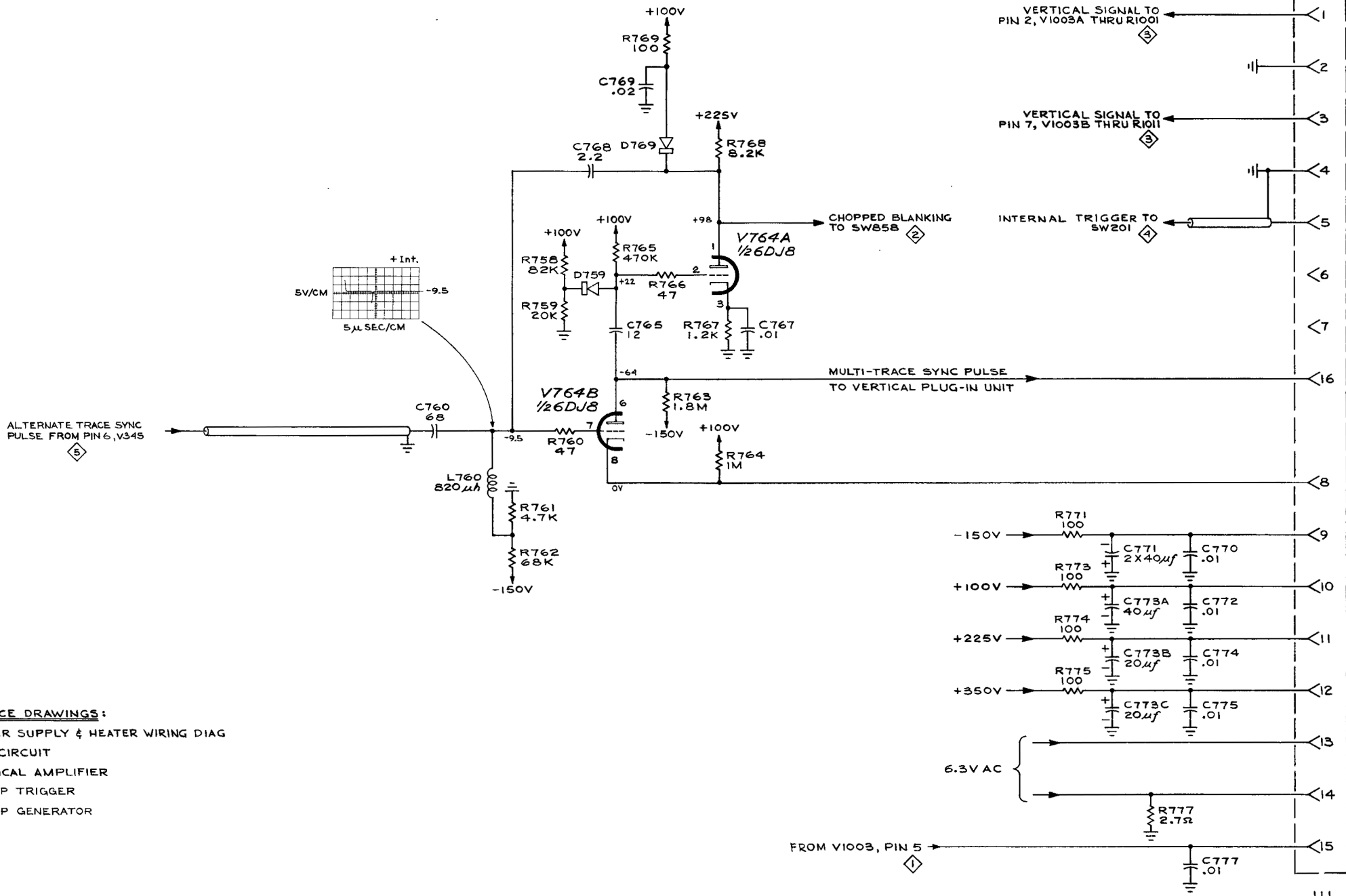

- REFERENCE DRAWINGS:**
- ① POWER SUPPLY & HEATER WIRING DIAG
  - ② CRT CIRCUIT
  - ③ VERTICAL AMPLIFIER
  - ④ SWEEP TRIGGER
  - ⑤ SWEEP GENERATOR

## CALIBRATOR

WAVEFORM AND DYNAMIC VOLTAGE READINGS were obtained under the following conditions:

AMPLITUDE CALIBRATOR . . . . . 10 Volts

POWER . . . . . ON

Also see IMPORTANT note on Block Diagram.

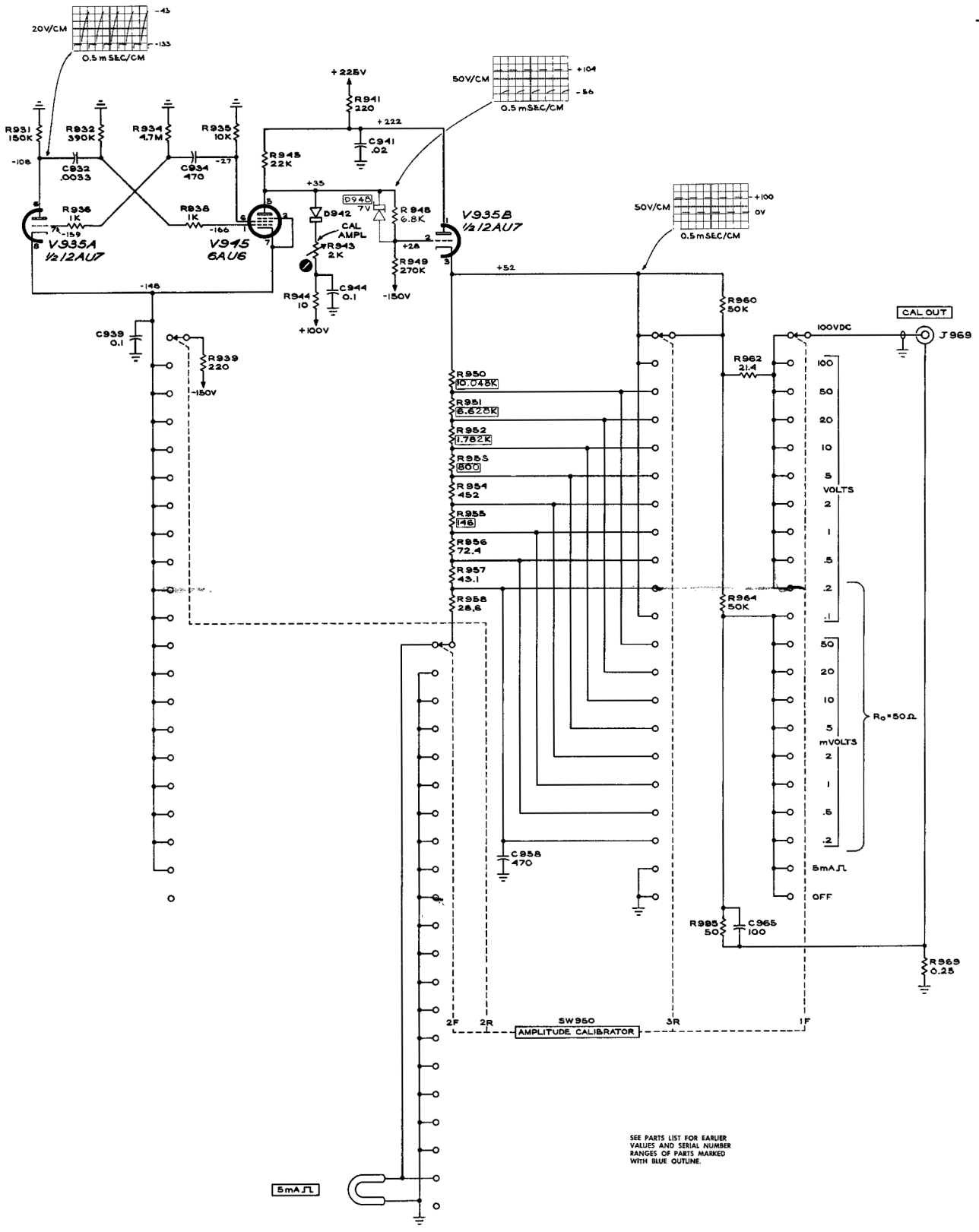

TYPE 544 OSCILLOSCOPE

<http://manoman.sghill.com>

SEE PARTS LIST FOR EARLIER VALUES AND SERIAL NUMBER RANGES OF PARTS MARKED WITH BLUE OUTLINE.

CMD 166  
CALIBRATOR

## **MANUAL CHANGE INFORMATION**

At Tektronix, we continually strive to keep up with latest electronic developments by adding circuit and component improvements to our instruments as soon as they are developed and tested.

Sometimes, due to printing and shipping requirements, we can't get these changes immediately into printed manuals. Hence, your manual may contain new change information on following pages. If it does not, your manual is correct as printed.

TYPE 544 TENT SN 640

PARTS LIST CORRECTION

CHANGE TO:

D672A,B,C,D      152-0066-00      S licon

M9973/666



TYPE 544/RM544 TENT SN 600

PARTS LIST CORRECTION

CHANGE TO:

R806            302-0823-00            82 k $\Omega$             1/2 W            10%

SCHEMATIC CORRECTION

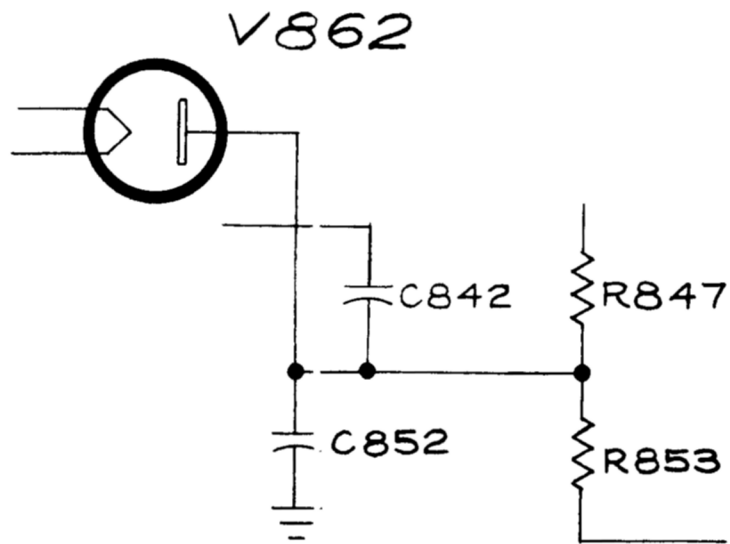

PARTIAL CRT

TYPE 544/RM544    TENT SN 620

PARTS LIST CORRECTION

CHANGE TO:

C1035, C1038

C1048, C1069

C1071, C1087

C113, C1132

283-0078-00

0.001  $\mu$ F    Cer    1 KV

M10985/666

Type 544, 546, 547, and ALL RM'S

TEXT CORRECTION

CALIBRATION

Replaces steps 12 and 13 only of 544/RM544.

Replaces steps 12, 13, 17 and 18 of 546/RM546, 547/RM547.

ALL notes in ( ) refer to MAIN TIME BASE (B).

Adjust A (B) TRIGGERING LEVEL CENTERING R225 (R25) and A TRIGGER SENS R245 (R45) --A (B) Sweep Trigger

- a. Set the AMPLITUDE CALIBRATOR switch to 50 m volts.
- b. Insert the BNC T connector between the AMPLITUDE CALIBRATOR connector and the coaxial cable.
- c. Connect another coaxial cable from the T connector to the A (B) TRIGGER INPUT connector. (The CAL OUT connector should now be connected to the Ext Input connector on the Type TU-7 and to the A (B) TRIGGER INPUT connector on the oscilloscope.)
- d. Set the TU-7 front-panel controls as follows:

Variable	Fully clockwise
Position	Centered
Test Function	Low Load
- e. Set the A (B) MODE switch to TRIG and the A (B) TRIGGERING LEVEL control to 0. Check that the A (B) COUPLING switch is set at AC and the A (B) SOURCE switch is set to EXT.
- f. Locate the junction of R217 (R17), C218 (C18), and R218 (R18). Connect the short jumper clip lead between the junction and ground. This jumper disables into A TRIGGERING LEVEL control.
- g. Connect a 10X Probe from the test oscilloscope the junction of R245 (R45) - R248 (R48).

- h. Set the test oscilloscope controls as follows:

Input coupling	Ac
Volts/Div	.02
Time/Div	.2 ms

## Triggering

Mode	Automatic
Slope	+
Coupling	Ac
Source	Internal

- i. Set the TRIGGER SENS R245 (R45) to midrange.
- j. Rotate TRIGGER LEVEL CENTERING R225 (R25) fully counterclockwise.
- k. Rotate TRIGGER LEVEL CENTERING R225 (R25) clockwise until a stable display 2 to 3 major divisions high appears on the test oscilloscope.
- l. If no stable display appears on the test oscilloscope, rotate the TRIGGER SENS R245 (R45) slightly clockwise, then repeat part k.
- m. Change the Triggering SLOPE switch to - and check for a stable display on the test oscilloscope. If necessary readjust the TRIGGER LEVEL CENTERING R225 (R25) slightly so as to obtain a stable test oscilloscope in both positions of the A (B) SLOPE switch.
- n. If a stable test oscilloscope display can not be obtained for both A (B) SLOPE switch positions, rotate the TRIGGER SENS R245 (R45) slightly clockwise and repeat part m.
- o. After obtaining a stable test oscilloscope display for both A (B) SLOPE switch positions, rotate the TRIGGER SENS R245 (R45) slightly counterclockwise. Again check for a stable test oscilloscope display in both positions of A (B) SLOPE switch. TRIGGER LEVEL CENTERING R225 (R25) may have to be readjusted slightly.
- p. Continue rotating the TRIGGER SENS R245 (R45) slightly counterclockwise and then checking the test oscilloscope display until a stable test oscilloscope display can not be obtained for both positions of the Triggering SLOPE switch.
- q. Rotate the TRIGGER SENS R245 (R45) just enough clockwise to permit a stable test oscilloscope display to be obtained for both positions of the Triggering SLOPE switch. Slight readjustment of TRIGGER LEVEL CENTERING R225 (R25) will probably be necessary.

TYPE 544  
TYPE RM544 TENT S/N 510

PARTS LIST CORRECTION

CHANGE TO:

C1019	281-0505-00	12 pF	Cer	500 V
-------	-------------	-------	-----	-------