

52504
485
2215

SERVICETEKNOTES

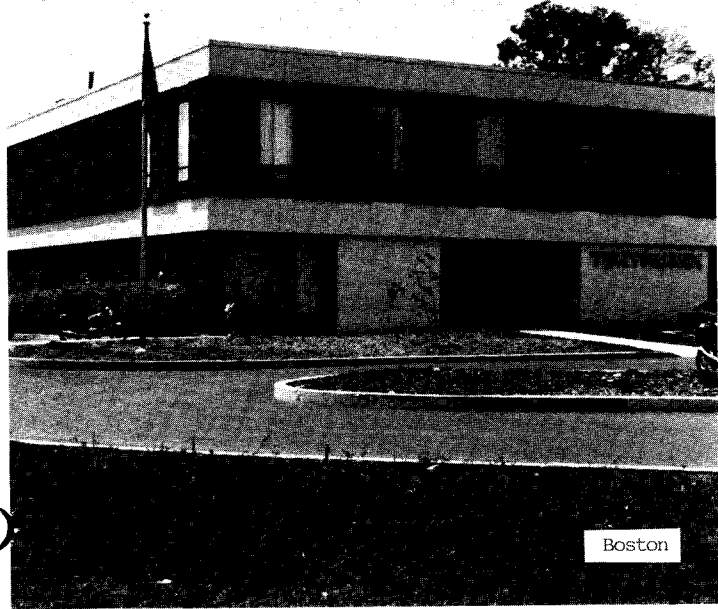

Boston

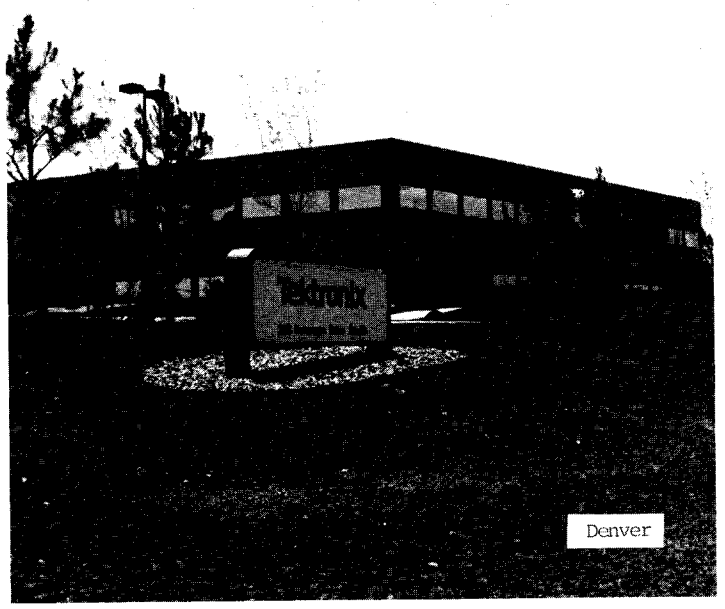

Denver

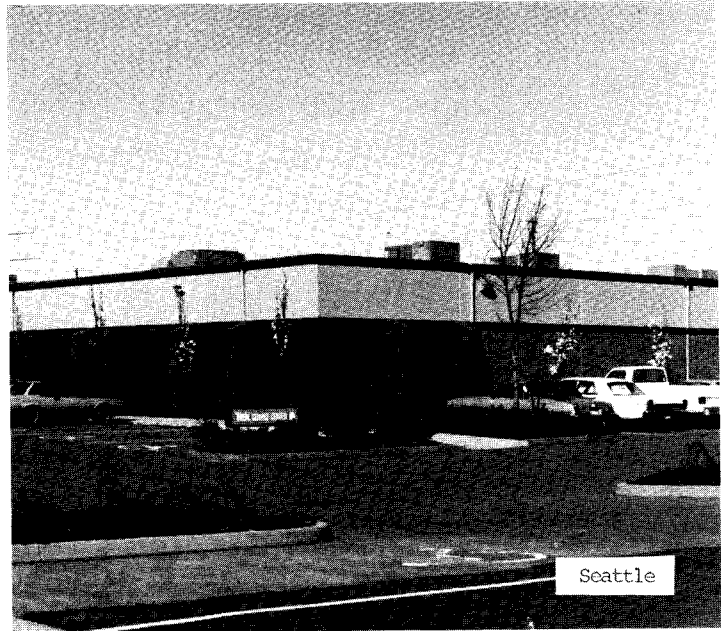

Seattle

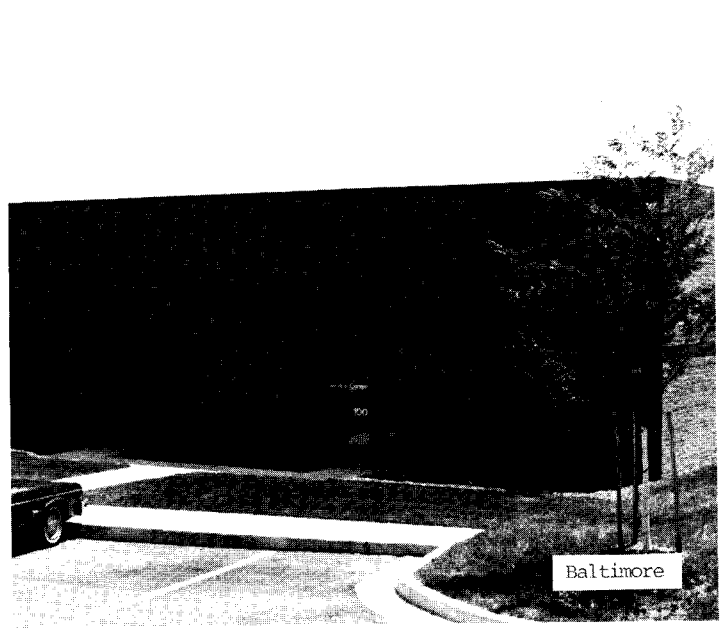

Baltimore

TABLE OF CONTENTS

ADVANCE NOTICE "MINIMUM ORDER POLICY"	1
DC5010 H.F. COUNTING FLUCTUATES BY 4 OR 5 LEAST SIGNIFICANT DIGITS	1
R230 100% MEMORY RANGE, R1154.	2
→ SC504 PERFORMANCE IMPROVED	3 ←
S-3200 PDP11/35 EIS REVISION F CAUSES GRAPHICS ERRORS.	3
S-3200 SERIES NEW STYLE FLIP CHIP FOR PDP 11	3
S-3200 SERIES RACK NAME PLATES	3
TV MANUALS REVISIONS	4
TV MANUALS REVISIONS	4
TV MANUALS REVISIONS	4
TV PRODUCTS, CRT NECK PINS	5
7B80 REPLACEABLE ELECTRICAL PARTS LIST CORRECTION.	5
7D10 MANUAL CORRECTION	7
7D15 MANUAL CORRECTION	7
7L14 PHASE LOCK ASSEMBLY A48	7
434 - ACCESSORY POUCH PARTS BREAKDOWN.	7
→ 485 1 MEGOHM ABERRATION ADJUSTMENT PROBLEM	7 ←
690SR/6942 HI RATE OPERATION	8
1440 TEST POINT VOLTAGES	8
1502 TD BIAS STABILITY	10
1800 DC SUBSYSTEM POWER SUPPLIES INDEX NUMBER REVERSED	10
1800 SERIES TEST STATION PRAM CONFIGURATION INFORMATION.	10
1800 SERIES TEST STATIONS SECTOR I/O TEST FIXTURE, PINS PART NUMBER.	11
→ 2213/2215 ATTENUATOR SWITCH SHAFT SUPPORT BUSHINGS REMOVED	11
→ 2213/2215 REPLACEABLE CABINET FOOT	11
→ 2215 ALTERNATE SWEEP BOARD SHIELD REMOVED.	12
4006/4010/402X/405X CHERRY KEYSWITCH REPLACEMENT	12
7612D PROGRAMMABLE DIGITIZER SERVICE MANUAL NOW AVAILABLE.	13

ADVANCE NOTICE "MINIMUM ORDER POLICY"

On February 21, 1983 Tektronix will institute a minimum order policy. The minimum order will be \$25.00 on all orders placed on or after that date.

It is not economically feasible for us to continue to process small orders which incur administrative costs in excess of the value of the parts/products ordered. We are confident you will recognize the need for this change since most of our industry already follows a similar practice.

We delayed this decision as long as we did because we did not want our customers to experience difficulty or excess costs in ordering from us.

If you do place an order with a total price of less than \$25.00, you will be billed \$25.00, plus applicable tax and transportation charges. If you request partial shipments, you will be billed for the items actually shipped plus a surcharge (difference between the total order price and \$25.00) with the first shipment. The billing for later shipments that are part of the same order will not include the surcharge.

If you have any questions regarding our minimum order policy, contact your Tektronix ordering office.

submitted by--
Sherm Bucher
Field Support

DC5010 H.F. COUNTING FLUCTUATES BY
4 OR 5 LEAST SIGNIFICANT DIGITS

Reference: A16 Digital Board

Fluctuation of >10kHz on the last four to five L.S.D.'s may occur when measuring frequencies between 100MHz to 350MHz (the symptom normally shows at 350MHz). First, vary the signal source to ensure it is not the cause of the erratic display. If the source is stable,

then the following modification should be done to improve the display:

1) One end of an insulated wire is soldered to the ground plane run located on the bottom front of the A16 Digital Board. See the diagram for the exact location.

(Scrape the solder mask from the run at the point of soldering, being careful not to damage the run. Too much heat on the run can separate it from the board, so use care when soldering.)

2) Solder the other end of the wire to the ground plane which attaches together Pin 7 of U1120 and Pin 8 of U1121 and U1122. (Follow the soldering procedure in Step 1.)

In some extreme cases U1120 may be part of the noise and will have to be replaced.

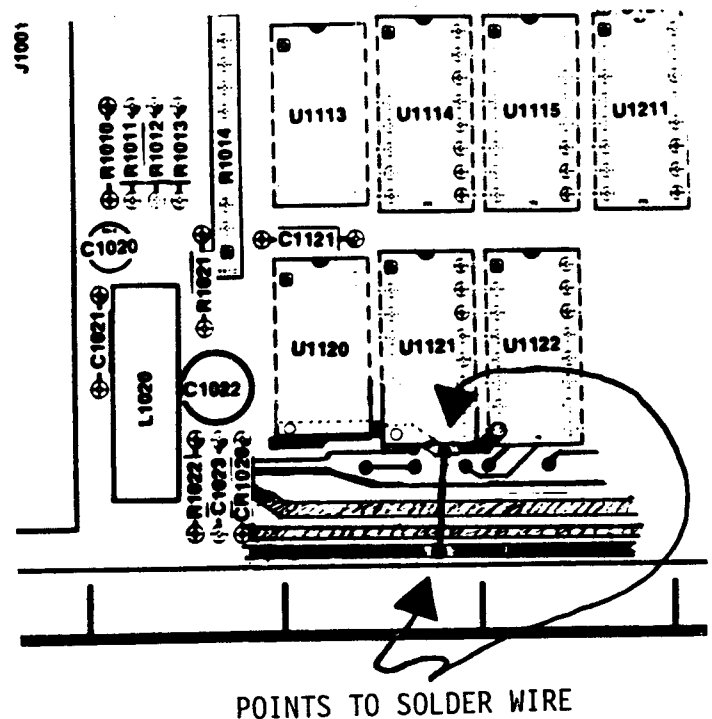

W² Issue 13-1

R230 100% MEMORY RANGE, R1154

Reference:

070-1976-00 230/R230 Digital Unit
 670-0232-00 CHA/CHB Memory

The 100% memory range test and adjustment section of the 070-1976-00 manual includes a check procedure for the 100% memory discharge voltage level. Section 9 on pages 7-6 and 7-7 checks and adjusts R1154 for a -2 volt level (with a ± 0.5 volts tolerance) below ground reference.

The tolerance range for the -2 volt (R1154) adjustment has been changed from ± 0.5 volts to to + 0.5V through -1.5V from the -2 Volt level. From Ground reference, the R1154 Adjustment range is -1.5 Volts to -3.5 Volts.

In some instances when Q1155 (151-1002-00) is a Motorola part, the wider tolerance range is necessary. The increased tolerance window will not affect memory operation or operating specifications.

W² Issue 13-2

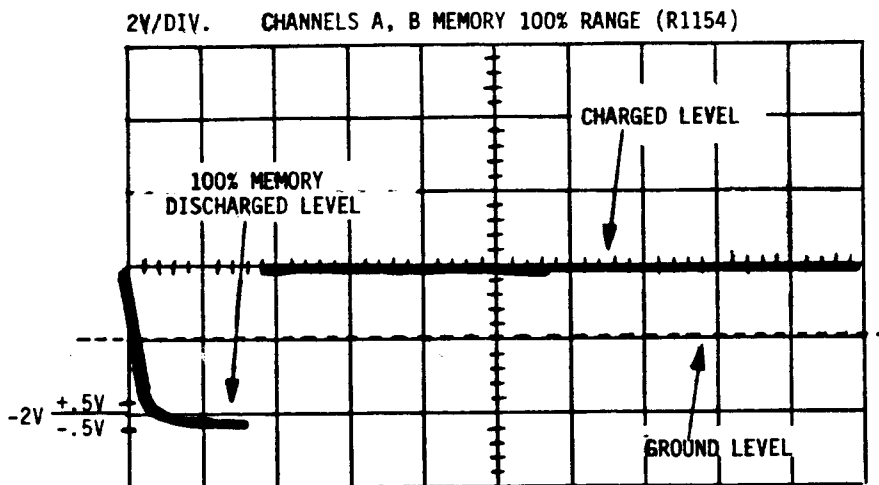

070-1976-00 FIG. 7-4 (B)
 OLD ADJUSTMENT RANGE LIMITS -2V ($\pm .5V$)

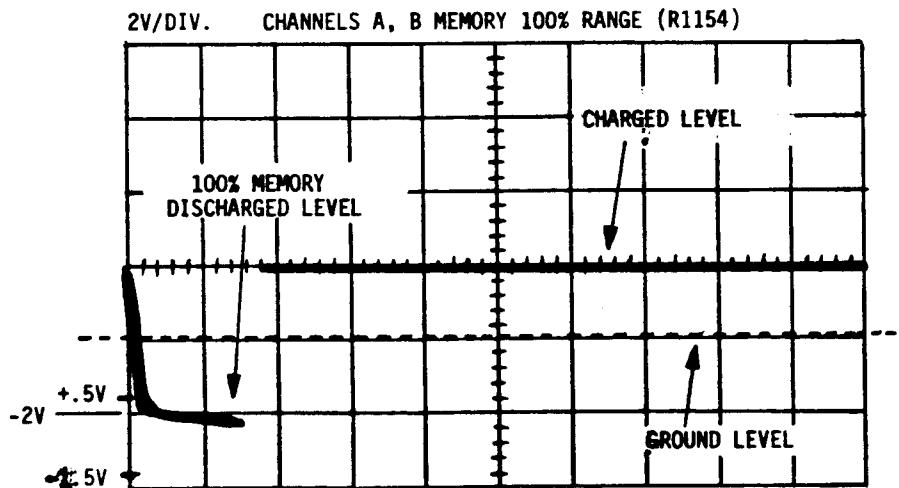

070-1976-00 FIG. 7-4 (B)
 NEW ADJUSTMENT RANGE LIMITS -2V (+.5V, AND -1.5V)

SC504 PERFORMANCE IMPROVED

Serial Number: B012285 and below.

A new mod kit, P/N 040-0974-01, will improve high frequency triggering, improve the vertical amplifier gain stability with respect to temperature, increase CRT beam current adjustment range, and will improve sweep linearity in the 50 and 100 nsec/Div ranges.

W² Issue 12-25

S-3200 PDP11/35 EIS REVISION F CAUSES GRAPHICS ERRORS

Installation of F revision EIS (Extended Instruction Set KE11-E) board into the PDP11/35 will cause problems with the graphics on some Tektest programs. Most systems that use the PDP11/35 as a controller have the revision D or E installed. The EIS board (labeled M7238) is the second board from the front. The revision of the board is stamped on the metal support bar. All EIS boards which DEC repairs or replaces will automatically be updated to the revision F level.

A simple way to check for the revision F is to run CMPCAL, C100 ident RCL. The resulting graph will be missing upper and right side line of the graph. The 30V reference nomenclature that should be on the bottom right will be displayed on the left side. There will be no zero base line in the middle of the graph. Two other tests that will display similar results are C070 and C145.

There is work being done to resolve this problem. This article is to make those using the PDP11/35 as a controller aware of this situation.

W² Issue 12-25

S-3200 SERIES NEW STYLE FLIP CHIP FOR PDP 11

Systems that utilize DMA type boards in the PDP11 need a newer type flip chip when the DMA type board is removed. When a DMA type board, i.e. GPIB, is installed the Non-Processor Grant (NPG) chaining short is removed from that back plane slot. When the DMA type board is removed this leaves the NPG line open. Installing the small Flip Chip Bus Grant card DEC P/N G727 will allow the system to function as a software system only. With the small flip chip installed the NPG line is left open preventing the Test Station Control Unit from giving an interrupt to start a test.

If a DMA type board is removed from the PDP 11, make sure that the two wide NPG and Bus Grant card (G7273) is installed in slots C & D. The G7273 is the number on the pull tab of the card, it is a DEC card and there is no Tektronix part number.

Another option is to use the smaller Bus Grant card and wirestrap CA1 to CB1 in the slot from where the DMA Board was removed. This is not ideal when there are plans for reinstalling the DMA Board in the future. The strap must be removed when the DMA Board is reinstalled.

W² Issue 13-2

S-3200 SERIES RACK NAME PLATES

The name plates listed in the **Power Control, Interconnect, and Racks Manual** (070-3471-00) are for the S-3270 System. The manual was written for the S-3270 but a majority of the parts relate to all S-3200

(ARTICLE CONTINUED ON THE NEXT PAGE)

S-3200 SERIES RACK NAME PLATES (cont.)

Series Systems except the S-3220 and S-3295. The S-3250 short racks used different side panels and doors as might be expected. One of the parts that is not universal is the rack plates shown on Fig. 2 Index 43. There are two colors of these plates plus different wording. For systems that have a blue side panel, Fig. 2 Index 7, the plates are light blue. For racks that have gray side panels the plates are dark blue.

The following is a list of the plates available for S-3200 Series Systems:

**Light Blue Color
With Power Switch Slot**

<u>Wording</u>	<u>Part Number</u>
S-3270	

**Light Blue Color
Without Power Switch Slot**

<u>Wording</u>	<u>Part Number</u>
Tektronix	334-2958-09
Blank	334-2958-00

**Dark Blue Color
With Power Switch Slot**

<u>Wording</u>	<u>Part Number</u>
S-3250	334-3577-01
S-3270	334-3292-01
S-3275	
S-3280	334-3293-01
Tektronix	334-3577-03

**Dark Blue Color
Without Power Switch Slot**

<u>Wording</u>	<u>Part Number</u>
Blank	334-3577-00
Tektronix	334-3577-02

W² Issue 13-2

TV MANUAL REVISIONS

The following manuals have been revised as of October 1982.

TSG12 070-2329-00

W² Issue 12-25

TV MANUALS REVISIONS

The following manuals have been revised and updated as of November 1982.

<u>Instrument</u>	<u>Manual P/N</u>
528A	070-3662-00
TSG11	070-2328-00
1980 Operators	061-2259-01
1420, 1421, 1422	
B050000 and Up	070-2899-00
TDC1, TDC2	
Opt. 2 and 12	070-3719-00
521A	070-1794-00
TSG2	
B020470 and Up	070-2599-00
650HR Series	070-2646-01

The 650HR Series has been revised to remove those parts which were formerly associated with the 650A series only. This removes a substantial amount of redundant material and will make the overall manual much more useable for the technician. Data has also been added for the 652HR and 652HR-1, which are PAL-M versions of the color monitor.

W² Issue 12-25

TV MANUALS REVISIONS

The following manuals have been revised/released as of November/December, 1982.

1980 Service Manual Volume 2
070-4494-00

(ARTICLE CONTINUED ON THE NEXT PAGE)

TV MANUALS REVISIONS (cont.)

1980 Service Installation

070-3742-00

380 NTSC Test Monitor

070-3421-00

TSG 6 NTSC Multiburst Generator

070-2528-00

SPG1/2 NTSC Sync Generator

070-2104-00

1474 NTSC Color Sync Generator

070-2097-00

W² Issue 13-27B80 REPLACEABLE ELECTRICAL
PARTS LIST CORRECTION

An error in the 7B80 service manual, P/N 070-1959-00, has omitted numerous part numbers for resistors.

(CHART ON THE FOLLOWING PAGE)

W² Issue 12-25TV PRODUCTS, CRT NECK PINS

REF: 520A Manual 070-1709-00
521A Manual 070-1794-00
522A Manual 070-1874-00
528A Manual 070-3662-00
1420 Series Manual 070-2899-00
1424 Manual 070-3893-00
1480 Series Manual 070-2338-00
Mod 46427

In order to improve the reliability of CRT neck pins in TV CRT products, Mod 46427 has replaced several types of CRT neck pin connectors with P/N 131-0472-01.

This part is a better design for the intended application, and should be used where intermittent or loose neck pin connectors have been a problem.

W² Issue 13-1

7B80 REPLACEABLE ELECTRICAL
PARTS LIST CORRECTION (cont.)

REPLACEABLE ELECTRICAL PARTS LIST CORRECTION

ADD:	Ckt No.	Tektronix Part No.	Serial/Model No. Eff	Dscont	Name & Description
	R372	315-0102-00			RES.,FXD,CMPSN: 1K OHM,5%,0.25W
	R381	315-0202-00			RES.,FXD,CMPSN: 2K OHM,5%,0.25W
	R382	315-0270-00			RES.,FXD,CMPSN: 27 OHM,5%,0.25W
	R383	315-3510-00			RES.,FXD,CMPSN: 51 OHM,5%,0.25W
	R410	311-1781-00			RES.,VAR,NONWIR: 10K OHM,10%,0.50W
	R412	315-0513-00			RES.,FXD,CMPSN: 51K OHM,5%,0.25W
	R413	315-0105-00			RES.,FXD,CMPSN: 1M OHM,5%,0.25W
	R414	321-0362-00			RES.,FXD,FILM: 57.8K OHM,1%,0.125W
	R415	311-1781-00			RES.,VAR,NONWIR: 10K OHM,10%,0.50W
	R416	321-0289-00			RES.,FXD,FILM: 10K OHM,1%,0.125W
	R422	315-0101-00	B010100 - B030944		RES.,FXD,CMPSN: 100 OHM,5%,0.25W
	R422	315-0680-00	B030945		RES.,FXD,CMPSN: 68 OHM,5%,0.25W
	R424	323-0285-00			RES.,FXD,FILM: 9.09K OHM,1%,0.50W
	R426	315-0180-00			RES.,FXD,CMPSN: 18 OHM,5%,0.25W
	R427	315-0103-00			RES.,FXD,CMPSN: 10K OHM,5%,0.25W
	R428	315-0473-00			RES.,FXD,CMPSN: 47K OHM,5%,0.25W
	R430	311-1423-00			RES.,VAR,NONWIR: 20 OHM,20%,0.50W
	R431	321-0122-00			RES.,FXD,FILM: 182 OHM,1%,0.125W
	R432	315-0180-00			RES.,FXD,CMPSN: 18 OHM,5%,0.25W
	R433	315-0820-00			RES.,FXD,CMPSN: 82 OHM,5%,0.25W
	R434	323-0285-00			RES.,FXD,FILM: 9.09K OHM,1%,0.50W
	R435	321-0400-00			RES.,FXD,FILM: 143K OHM,1%,0.125W
	R436	315-0180-00			RES.,FXD,CMPSN: 18 OHM,5%,0.25W
	R437	315-0103-00			RES.,FXD,CMPSN: 10K OHM,5%,0.25W
	R438	315-0473-00			RES.,FXD,CMPSN: 47K OHM,5%,0.25W
	R439	315-0151-00			RES.,FXD,CMPSN: 150 OHM,5%,0.25W
	R440	315-0470-00			RES.,FXD,CMPSN: 47 OHM,5%,0.25W
	R441	315-0682-00			RES.,FXD,CMPSN: 6.8K OHM,5%,0.25W
	R442	321-0225-06			RES.,FXD,FILM: 2.15K OHM,0.25%,0.125W
	R444	322-0210-00			RES.,FXD,FILM: 1.5K OHM,1%,0.25W
	R445	311-1226-00			RES.,VAR,NONWIR: 2.5K OHM,20%,0.50W
	R446	315-0682-00			RES.,FXD,CMPSN: 6.8K OHM,5%,0.25W
	R447	321-0928-03			RES.,FXD,FILM: 250 OHM,0.25%,0.125W
	R448	322-0218-00			RES.,FXD,FILM: 1.82K OHM,1%,0.25W
	R449	322-0224-00			RES.,FXD,FILM: 2.10K OHM,1%,0.25W
	R454	322-0210-00			RES.,FXD,FILM: 1.5K OHM,1%,0.25W
	R455	321-0124-00			RES.,FXD,FILM: 191 OHM,1%,0.125W
	R456	315-0682-00			RES.,FXD,CMPSN: 6.8K OHM,5%,0.25W
	R457	321-0928-03			RES.,FXD,FILM: 250 OHM,0.25%,0.125W
	R458	322-0218-00			RES.,FXD,FILM: 1.82K OHM,1%,0.25W
	R459	322-0224-00			RES.,FXD,FILM: 2.10K OHM,1%,0.25W
	R705	311-0467-00			RES.,VAR,NONWIR: 100K OHM,20%,0.50W
	R706	321-0438-00			RES.,FXD,FILM: 357K OHM,1%,0.125W
	R710	311-1232-00			RES.,VAR,NONWIR: 50K OHM,20%,0.50W
	R711	321-0458-00			RES.,FXD,FILM: 576K OHM,1%,0.125W
	R712	315-0273-00			RES.,FXD,CMPSN: 27K OHM,5%,0.25W
	R713	315-0273-00			RES.,FXD,CMPSN: 27K OHM,5%,0.25W
	R714	321-0363-00			RES.,FXD,FILM: 59K OHM,1%,0.125W
	R715	311-1232-00			RES.,VAR,NONWIR: 50K OHM,20%,0.50W
	R717	321-0360-00			RES.,FXD,FILM: 54.9K OHM,1%,0.125W
	R721	315-0121-00			RES.,FXD,CMPSN: 120 OHM,5%,0.25W
	R722	321-0225-06			RES.,FXD,FILM: 2.15K OHM,0.25%,0.125W
	R723	321-0642-00			RES.,FXD,FILM: 20.3K OHM,0.25%,0.125W
	R724	315-0682-00			RES.,FXD,CMPSN: 6.8K OHM,5%,0.25W
	R725	311-1590-00			RES.,VAR,NONWIR: 10K OHM,10%,1W
	R728	301-0302-00			RES.,FXD,CMPSN: 3K OHM,5%,0.50W
	R729	315-0101-00			RES.,FXD,CMPSN: 100 OHM,5%,0.25W
	R731	315-0221-00			RES.,FXD,CMPSN: 220 OHM,5%,0.25W

7D10 MANUAL CORRECTION

RE: 7D10 Instruction Manual
P/N 070-2148-00

When performing any type of "External" or "Line" triggering check, the signal that's applied to the "Ext Trig In" connector must also be applied to the "Events Start Trig In" connector. This change effects steps A5, A6, and A7 in the manuals performance check.

W² Issue 12-25

7D15 MANUAL CORRECTION

RE: 7D15 Instruction Manual
P/N 070-1433-00

When checking the External clock on page 5-11, Step e should read "to check for a 2Hz waveform" instead of 20Hz.

W² Issue 12-25

7L14 PHASE LOCK ASSEMBLY A48

RE: MOD #46970

The part number for the 7L14 Phase Lock Assembly A48 has been changed to 644-0444-01 from 644-0444-00. The part number was changed because of the need to differentiate between the 7L13 Phase Lock Assembly (644-0444-00) and the Phase Lock Assembly in the 7L14. There are selected components in each assembly, their specific values dependent on whether the assembly is used in the 7L13 or 7L14.

W² Issue 12-24

434 - ACCESSORY POUCH PARTS BREAKDOWN

RE: P/N 016-0165-00

The following is a list of parts and their part numbers that make up the 434 accessory pouch.

<u>Description</u>	<u>Part Number</u>	<u>Quan.</u>
Vinyl Accessory Pouch	016-0535-01	1
Thumbscrew	213-0262-00	1
Washer (Under Thumbscrew)	210-0804-00	1
C-Clip (For Thumbscrew)	354-0290-01	1
Bottom Plate	386-2430-00	1
Backing Plates (inside pouch)	386-2418-00	2
Rubber Feet	348-0037-00	4
Screws (Bottom Front)	211-0012-00	2
Screws (Bottom Rear)	211-0097-00	2

W² Issue 12-25

485 1 MEGOHM ABERRATION ADJUSTMENT PROBLEM

If the 1 Megohm aberrations will not adjust properly even with the 50 ohm aberrations normal, R54 on the Hi-Z board may be at fault.

1. Check R54 to ensure it is 91 ohms (within 5%). Replace if necessary.
2. If the resistance is within tolerance, very carefully heat the solder connection at each end of the resistor (use a low wattage iron). This will eliminate a high resistance connection.
3. Repeat the 1 Megohm adjustments. This procedure will solve many previously unexplained compensation problems.

W² Issue 12-24

690SR/6942 HI RATE OPERATION

RE: 690SR Manual 070-3821-00
 690SR Opt. 40,48 Manual
 070-2870-00
 Mod 47649

Starting at S/N B011080 on the 6942 and B010410 on the 690SR, a mod was implemented to take care of three problems in the instrument. These changes all occur on the H Delay board, A11 A2.

1. At high scan rates (37.5 kHz) the unit would not always function properly since U332 was in voltage limit prior to the retrace command occurring. To correct this, VR335, an 11 volt Zener diode was added in parallel with C335, cathode to the U332-pin 6 end of C335 (see diagram).
2. To improve reliability, CR508, CR510 and CR521 were changed to burned-in parts (see diagram).
3. With the monitor set for a high scan rate mode, it occasionally would not free-run with the interface module removed. This was caused by the valley current of Q331, a Programmable-Unjunction Transistor, being too low in some devices. To eliminate the need to select Q331 for proper operation, a kit (050-1675-00) has been established that will add another transistor and a resistor in a "teepee" fashion to the circuit. This will insure high-rate, free-run capabilities. (See diagram.)

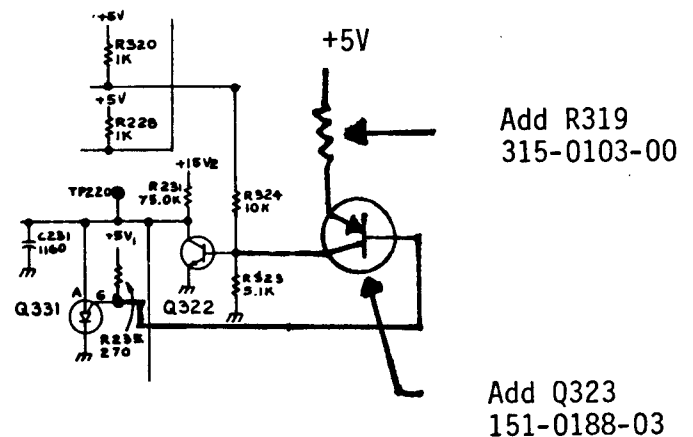
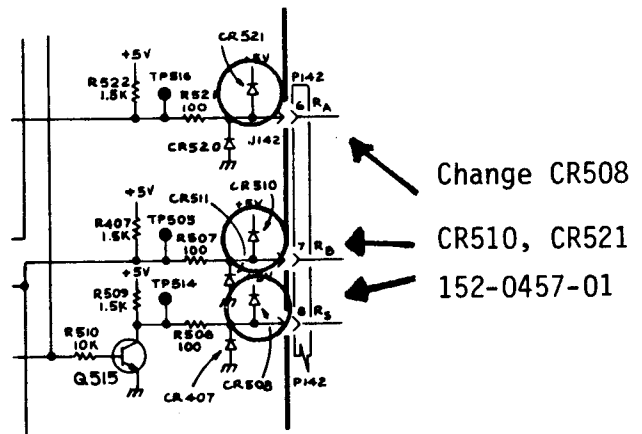

W² Issue 13-1

1440 TEST POINT VOLTAGES

REF: 1440 Manual 070-1498-02

When trying to determine whether or not adequate correction range exists while varying the controls on the Remote Control Unit, use the following numbers as close approximations.

When driving the 1440 under test with another 1440 and varying the above input parameters to the unit under test, the voltages at the test points should be close to, but slightly less than, those measured for the "RCU Manual" mode.

(CHART ON THE FOLLOWING PAGE)

W² Issue 13-2

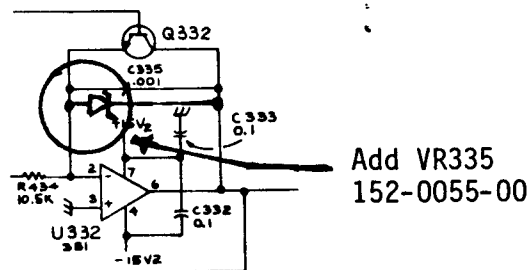

1440 TEST POINT VOLTAGES (cont.)

<u>FUNCTION</u>	<u>TEST POINT</u>	<u>VOLTAGE SWING</u>	<u>CENTER VOLTAGE</u>
RCU Manual Mode, Control Pots End-to-End			
Set-Up	P5494-4	-12 to +12	0
Master Gain	P5898-5	-10 to +13	+6
Chroma Gain	P5898-1	-11 to +12	0
Burst Phase	P5198-5	-13 to +13	0
Burst Gain	P5198-2	-12 to +12	0
Sync Gain	P5498-6	-12 to +6	-7
RCU VIRS Mode, VIRS Pots End-to-End			
Set-Up	P5498-4	-6 to +5	0
Master Gain	P5898-5	+3 to +9	+6
Chroma Gain	P5898-1	-3 to +3	0
Burst Phase	P5198-5	-4 to +3	0
Burst Gain	P5198-2	-4 to +1	0
Sync Gain	P5498-6	-8 to -6	-7
RCU VIRS (No incoming VIRS on Video) Preset Pots End-to-End			
Set-Up	P5498-4	-12 to +13	0
Master Gain	P5898-5	-10 to +13	+6
Chroma Gain	P5898-1	-11 to +12	0
Burst Phase	P5198-5	-13 to +13	0
Burst Gain	P5198-2	-12 to +13	0
Sync Gain	P5498-6	-10 to -4	-7

1502 TD BIAS STABILITY

RE: MOD 48913

To improve the stability of the TD Bias adjustment when temperature variations are encountered, the capacitor C1596, located on the Main Board, has been changed to a more stable type. The part number for this new 470pf capacitor is 283-0597-00.

W² Issue 12-25

1800 DC SUBSYSTEM POWER SUPPLIES INDEX NUMBER REVERSED

On the illustrations of the DC Subsystem power supply, the index numbers are reversed. The part number for the 15 volt supply (PS300) is 119-0440-01. The part number for the 5 volt supply (PS100) is 119-0439-01. The following manuals need the index numbers on the illustration reversed as follows in TABLE 1.

W² Issue 12-25

TABLE 1

<u>Manual</u>	<u>Part Number</u>	<u>Fig. #</u>	<u>Change</u>
1803 DC Subsystem	070-3144-02	Fig. 1 (Pg. 6-3)	Index 46 becomes 48 Index 48 becomes 46
1804 Volume 2	070-3331-01	Fig. 4	Index 114 becomes 111 Index 111 becomes 114
1804 Volume 2	070-3331-02	Fig. 4	Index 98 becomes 101 Index 101 becomes 98
1805 Volume 2	070-3338-00	Fig. 5	Index 120 becomes 123 Index 123 becomes 120
1807 Volume 2	070-4134-00	Fig. 4	Index 98 becomes 101 Index 101 becomes 98

1800 SERIES TEST STATION PRAM CONFIGURATION INFORMATION

There are two entries not shown in the verdict manual, 061-2125-00, for the Pram. Originally, there were only 27 entries needed for the Pram. If error storage (Mod 40006) is added to the system, entry 28 is needed. If Pram level 5 is added to the system, then entry 28 and

29 are needed. Pram level 5 requires Tektest III, Version 4.

Below is the new Pram configuration as it would be, if Pram level 5 was installed in the system. Remember, the number of entries in the table must match the "Entries per station" line.

(ARTICLE CONTINUED ON THE NEXT PAGE)

1800 SERIES TEST STATION PRAM
CONFIGURATION INFORMATION (cont.)

PATTERN RAM OPTION (PRAM)

Hardware Device Name: PRAM

Entries Per Station: 29

Configuration Data

1	ERROR FLAG	Enter the pin electronics number used to provide these Pram output signals. Enter a 0 for no connection.	
2	COMMAND FLAG		
3	RA 0		
.			
.			
14	RA 11		
15	RB 0		
.			
.			
26	RB 11		
27	1 or 4		1 = 1K memory
28	0, 1 or 2		4 = 4K memory
29	5		0 = Pre-error storage modificatio 1 = Store errors 2 = Store error pairs

Pram Configuration Data.

W² Issue 12-25

1800 SERIES TEST STATIONS SECTOR
I/O TEST FIXTURE, PINS PART NUMBER

The part number for the pins used on the 067-0753-00, Sector Card I/O Test Fixture, is 131-1720-00.

W² Issue 13-2

2213/2215 ATTENUATOR SWITCH SHAFT
SUPPORT BUSHINGS REMOVED

RE: 2215 MANUAL, P/N 070-3826-00
FIG. 1 - 27 BUSHING
FIG. 1 - 41 SPACER POST
FIG. 1 - 37 SUBPANEL
PICN # 81, 90

A 2 step change has been made to the front support for the vertical attenuator switch shafts.

1. The bushing (Fig. 1 - 27) and spacer post (Fig. 1 - 41) were removed and a plastic Grommet, P/N 348-0442-00, added for support of both switch shafts. This change was implemented at:

2213 S/N B026270
2215 S/N B028514

2. The front subpanel (Fig 1 - 37) was changed by decreasing the diameter of the holes used for the Attenuator shafts. The holes now provide support for the switch shafts.

The part number of the subpanel was not changed. Therefore, if a subpanel is ordered and used as a replacement in an earlier unit, the support parts will have to be discarded as they are no longer necessary.

W² Issue 13-1

2213/2215 REPLACEABLE CABINET FOOT

RE: 2213 MANUAL, P/N 070-3827-00
FIG. 1-6, P/N 348-0659-01

When replacing the instrument cabinet bottom foot, use P/N 348-0659-01. This part has had a hole added to allow the foot to compress for installation into the cabinet hole.

(ARTICLE CONTINUED ON THE NEXT PAGE)

2213/2215 REPLACEABLE CABINET FOOT
(cont.)

The new part can be installed by placing a hex driver or similar tool into the hole in the foot and pushing the foot into the cabinet. Be sure to support the cabinet so it will not be bent.

W² Issue 13-2

2215 ALTERNATE SWEEP BOARD SHIELD REMOVED

RE: FIG 2 - 15
S/N B027295

The A13 Alternate Sweep board shield has been removed from all 2215 scopes above the listed serial number. It has been determined that it was not needed for either electrical or mechanical reasons.

Use of the shield in units below this serial number is optional.

W² Issue 13-1

4006/4010/402X/405X CHERRY KEYSWITCH REPLACEMENT

The late style cherry keyswitch, with the expanding mounting tabs, is difficult to remove from the keyboard without first cutting the mounting tabs off.

Older keyswitches have bumps, rather than locking expanding tabs; therefore, do not require cutting.

It has been found that the X-acto blade #11, 002-1040-00, with the long straight edge, works quite well in cutting the cherry keyswitch tabs. Insert blade in keyboard as pictured and cut off tab.

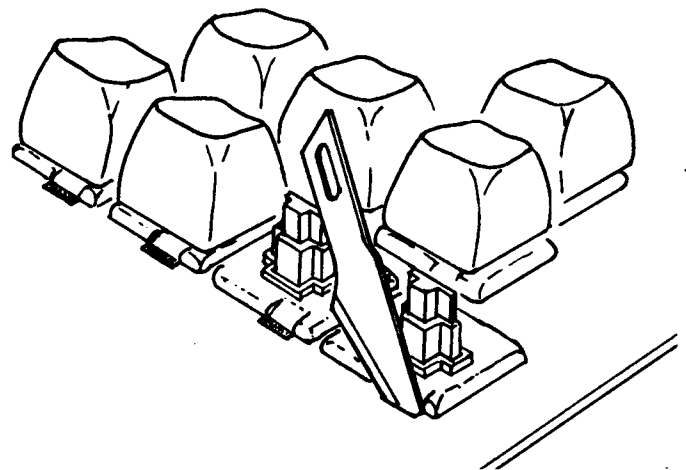
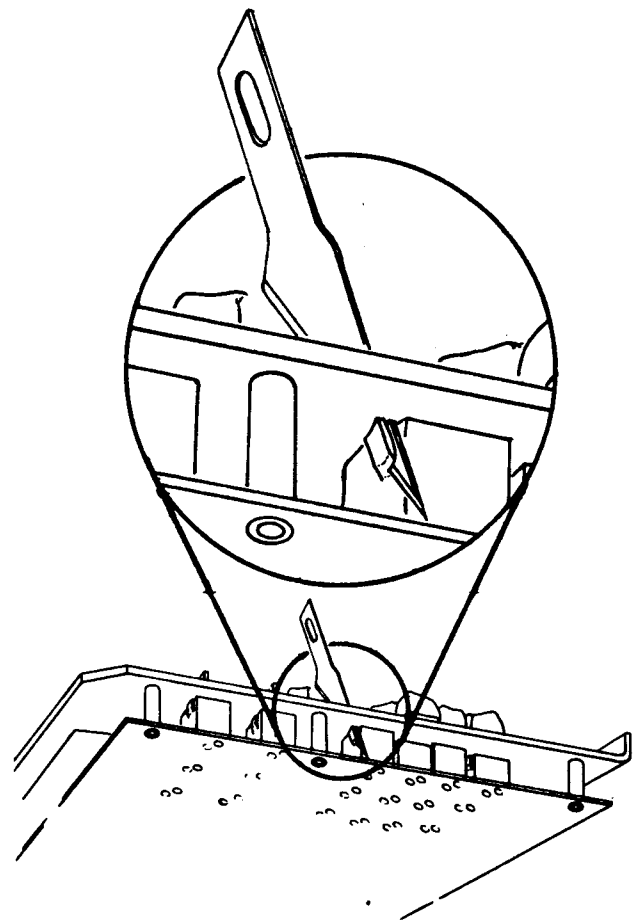

W² Issue 12-25

7612D PROGRAMMABLE DIGITIZER
SERVICE MANUAL NOW AVAILABLE

The 7612D Programmable Digitizer Service Manual P/N 070-2387-00 is now orderable.

This new manual is divided into nine sections which provide general and specific information concerning the installation, operation and maintenance of the 7612D, including a detailed circuit description and revised calibration procedure.

Specifications, characteristics and procedures appearing in this manual supercede any conflicting information which was contained in the Preliminary Service Manual.

W² Issue 13-1

The Tektronix Service Organization firmly supports a policy of assuring continued utility of products sold by Tektronix.

This publication is meant to provide technical information to the customer who has decided to maintain his own Tektronix products. It contains product servicing information and is written for the technician.

Articles are submitted primarily by Service Support Staff Engineers thoroughly familiar with the products they support. SERVICE TEKNOTES also encourages you, the user, to submit articles for publication. If you have knowledge of a technique, procedure or idea that enables you to service your Tektronix product more effectively, write it down so others may benefit from your experience.

Articles for publication should be submitted directly to:

Tektronix, Inc.
P.O. Box 500
Beaverton, Oregon 97077

Attention: Janet Hemenway
SERVICE TEKNOTES Editor

Delivery Station: 53-037

SERVICE TEKNOTES is distributed by Service Administrative Support free of charge to customers who maintain their own Tektronix equipment. A customer may be added to the distribution list by applying through his local Tektronix Sales Engineer.

Copyright ©1981, Tektronix, Inc. All rights reserved. Printed in U.S.A. Tektronix products are covered by U.S. and foreign patents, issued and pending. Information in this publication supersedes that in all previously published material. Specification and price change privileges reserved. TEKTRONIX, TEK, SCOPE-MOBILE, and  are registered trademarks of Tektronix, Inc. TELEQUIPMENT is a registered trademark of Tektronix U.K. Limited.

The Editor and staff of SERVICE TEKNOTES provide the material in this publication as a service to users of Tektronix Products. While we have tried to be diligent in assuring the accuracy of the material which we have printed, we cannot guarantee its accuracy. Neither SERVICE TEKNOTES, its editor and staff, Tektronix, Inc., nor its representatives assume any responsibility for the use of the material printed in SERVICE TEKNOTES; nor can we assume any responsibility for any errors or for the resulting effects of any errors.