



MULTIPURPOSE TEST STATION

M.P.T.S.

PULSE GENERATOR

INSTRUCTION MANUAL

Tektronix, Inc.
P.O. Box 500
Beaverton, Oregon 97077

Serial Number 3

Copyright © 1983 Tektronix, Inc. All rights reserved.
Contents of this publication may not be reproduced in any
form without the written permission of Tektronix, Inc.

Products of Tektronix, Inc. and its subsidiaries are covered
by U.S. and foreign patents and/or pending patents.

TEKTRONIX, TEK, SCOPE-MOBILE, and  are
registered trademarks of Tektronix, Inc. TELEQUIPMENT
is a registered trademark of Tektronix U.K. Limited.

Printed in U.S.A. Specification and price change privileges
are reserved.

TABLE OF CONTENTS

	Page
Title page	
Table of Contents	1
List of Illustrations	3
List of Tables	4
Operators Safety Summary	5
Service Safety Summary	6
Static-Sensitive Components	7
SECTION 1 DESCRIPTION AND SPECIFICATIONS -----	1-1
Purpose and Function -----	1-1
Connectors, Indicators, and Controls -----	1-1
Specifications -----	1-2
SECTION 2 OPERATOR INSTRUCTIONS -----	2-1
Installation and Removal -----	2-1
Functional Check -----	2-1
SECTION 3 THEORY OF OPERATION -----	3-1
Block Diagram Overview -----	3-1
Circuit Description -----	3-1

SECTION 4 CALIBRATION ----- 4-1

- Test Equipment Required ----- 4-1
- Preliminary Inspection and Connections ----- 4-1
- Power Supply Voltages ----- 4-2
- Power Supply Ripple ----- 4-2
- Bias Adjustment ----- 4-3
- Compensating Capacitor Adjustment ----- 4-4
- Frequency Check ----- 4-5
- Rise Time Measurement ----- 4-5
- Pretrigger Check ----- 4-5

SECTION 5 DIAGNOSTIC AND REPAIR SUGGESTIONS ----- 5-1

- Equipment Required ----- 5-1
- Technique ----- 5-1

SECTION 6 REPLACEABLE PARTS LISTS ----- 6-1

- Parts Ordering Information ----- 6-1
- Component Number System ----- 6-1
- Electrical Parts List ----- 6-3
- Mechanical Parts List ----- 6-10

SECTION 7 DIAGRAMS ----- 7-1

- Block Diagram ----- 7-2
- Schematic ----- 7-3

SECTION 8 INDEX ----- 8-1

LIST OF ILLUSTRATIONS

Fig. No		Page
	Front panel of Fastrise Pulse Generator -----	8
4-1	Bias Adj. Setup -----	4-2
7-1	Block Diagram -----	7-2
7-2	Schematic -----	7-3

LIST OF TABLES

1-1 Specifications ----- 1-2



OPERATORS SAFETY SUMMARY

The general safety information in this part of the summary is for both operating and servicing personnel. Specific warnings and cautions will be found throughout the manual where they apply, but may not appear in this summary.

TERMS

In This Manual

CAUTION statements identify conditions or practices that could result in damage to the equipment or other property.

WARNING statements identify conditions or practices that could result in personal injury or loss of life.

As Marked on Equipment

CAUTION indicates a personal injury hazard not immediately accessible as one reads the marking, or a hazard to property including the equipment itself.

DANGER indicates a personal injury hazard immediately accessible as one reads the marking.

SYMBOLS

In This Manual



This symbol indicates where applicable cautionary or other information is to be found.

As Marked on Equipment



DANGER — High voltage.



Protective ground (earth) terminal.



ATTENTION — refer to manual.

Power Source

This product is intended to operate in a power module connected to a power source that will not apply more than

250 volts rms between the supply conductors or between either supply conductor and ground. A protective ground connection by way of the grounding conductor in the power module power cord is essential for safe operation.

Grounding the Product

This product is grounded through the grounding conductor of the power module power cord. To avoid electrical shock, plug the power cord into a properly wired receptacle before connecting to the product input or output terminals. A protective ground connection by way of the grounding conductor in the power module power cord is essential for safe operation.

Danger Arising From Loss of Ground

Upon loss of the protective-ground connection, all accessible conductive parts (including knobs and controls that may appear to be insulating) can render an electric shock.

Use the Proper Fuse

To avoid fire hazard, use only the fuse of correct type, voltage rating and current rating as specified in the parts list for your product.

Refer fuse replacement to qualified service personnel.

Do Not Operate in Explosive Atmospheres

To avoid explosion, do not operate this product in an explosive atmosphere unless it has been specifically certified for such operation.

Do Not Operate Without Covers

To avoid personal injury, do not operate this product without covers or panels installed. Do not apply power to the plug-in via a plug-in extender.

SERVICE SAFETY SUMMARY

FOR QUALIFIED SERVICE PERSONNEL ONLY

Refer also to the preceding Operators Safety Summary.

Do Not Service Alone

Do not perform internal service or adjustment of this product unless another person capable of rendering first aid and resuscitation is present.

Use Care When Servicing With Power On

Dangerous voltages exist at several points in this product. To avoid personal injury, do not touch exposed connections and components while power is on.

Disconnect power before removing protective panels, soldering, or replacing components.

Power Source

This product is intended to operate in a power module connected to a power source that will not apply more than 250 volts rms between the supply conductors or between either supply conductor and ground. A protective ground connection by way of the grounding conductor in the power module power cord is essential for safe operation.

STATIC-SENSITIVE COMPONENTS

The following precautions are applicable when performing any maintenance involving internal access to the instrument.

CAUTION

Static discharge can damage any semiconductor component in this instrument.

This instrument contains electrical components that are susceptible to damage from static discharge. Table 6-1 lists the relative susceptibility of various classes of semiconductors. Static voltages of 1 kV to 30 kV are common in unprotected environments.

When performing maintenance, observe the following precautions to avoid component damage:

1. Minimize handling of static-sensitive components.
2. Transport and store static-sensitive components or assemblies in their original containers or on a metal rail. Label any package that contains static-sensitive components or assemblies.
3. Discharge the static voltage from your body by wearing a grounded antistatic wrist strap while handling these components. Servicing static-sensitive components or assemblies should be performed only at a static-free work station by qualified service personnel.
4. Nothing capable of generating or holding a static charge should be allowed on the work station surface.
5. Keep the component leads shorted together whenever possible.
6. Pick up components by their bodies, never by their leads.

**Table 6-1
Susceptibility
to Static Discharge Damage**

Semiconductor Classes	Relative Susceptibility Levels ^a
MOS or CMOS microcircuits or discretes, or linear microcircuits with MOS inputs. (Most Sensitive)	1
ECL	2
Schottky signal diodes	3
Schottky TTL	4
High-frequency bipolar transistors	5
JFETs	6
Linear microcircuits	7
Low-power Schottky TTL	8
TTL (Least Sensitive)	9

^aVoltage equivalent for levels: (Voltage discharged from a 100 pF capacitor through a resistance of 100 Ω.)

1 = 100 to 500 V 4 = 500 V 7 = 400 to 1000 V(est.)
 2 = 200 to 500 V 5 = 400 to 600 V 8 = 900 V
 3 = 250 V 6 = 600 to 800 V 9 = 1200 V

7. Do not slide the components over any surface.
8. Avoid handling components in areas that have a floor or work-surface covering capable of generating a static charge.
9. Use a soldering iron that is connected to earth ground.
10. Use only approved antistatic, vacuum-type desoldering tools for component removal.

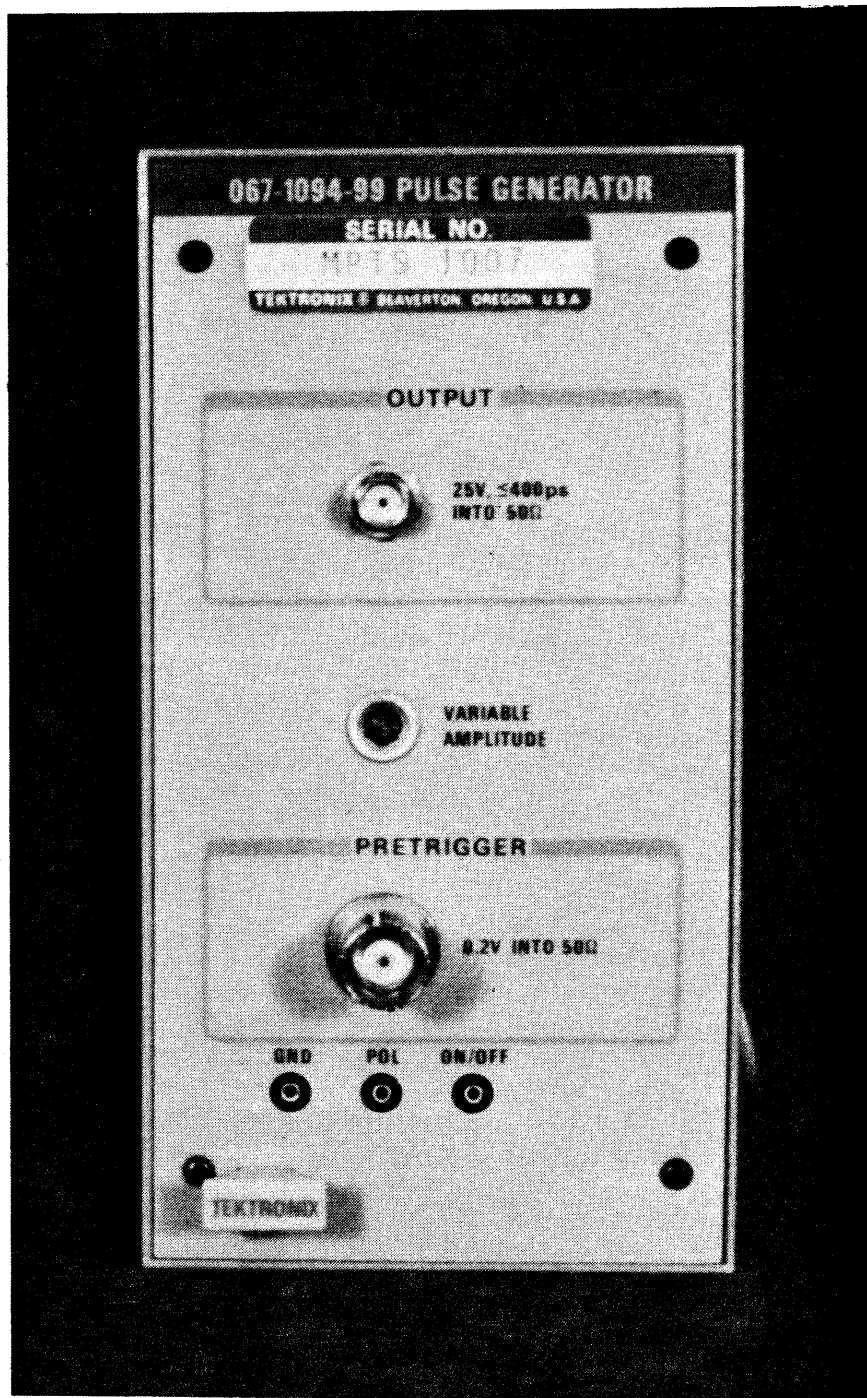

Front panel of Fastrise Pulse Gen.
FRONTISPIECE

SECTION 1
SPECIFICATION

1.1 Purpose and Function

For M.P.T.S., the High Amplitude Pulse Generator (067-1094-99) is often called the Fastrise Pulse Generator, or simply Pulse Generator. It is used for testing amplifier and attenuator step-response aberrations and flatness of the IUT. The generator is capable of creating 25 volt rectangular pulses 40 nanoseconds wide of either polarity. The risetime is 400 picoseconds or less and the repetition rate is nominally 50 kHz.

In M.P.T.S., the Fastrise Pulse Generator is used in combination with the GPIB Programmable Attenuator to give a series of discrete pulse amplitudes. The Fastrise Pulse Generator by itself is not a programmable instrument.

1.2 Connectors, Indicators, and Controls

The only external control is the Variable Amplitude control on the front panel. The pretrigger output is a BNC connector, and the pulse output is an SMA. The pretrigger is used as a oscilloscope trigger during calibration. There are three pin jacks on the front panel labeled: GND, POL, and ON/OFF.

Connecting POL and GND produces a negative pulse. It is not used on MPTS. ON/OFF is not connected.

The internal adjustments are discussed in Section 4, Calibration.

1.3 Specifications

PULSE GENERATOR SPECIFICATIONS
TABLE 1-1

ITEM	SPEC.	NOTES
Amplitude accuracy	+/- 10%	Measured into 50 ohms.
Amplitude Values	10 25 50 100 mV 250 500 mV 1 2.5 5 10 25 V	Into 50 ohms. These discrete values are available at the MPTS Prog. Atten. output when it is connected to the output of the Pulse Generator
Polarity	+ or -	MPTS does not spec. or use negative polarity.
Rise Time	<= 400 ps	Measured into 50 ohms in a 11.5 GHz system.
Pulse Width:	> 35 ns	40 ns typical.
Repetition Rate	50 kHz	Typical.
Aberrations		
First 10 ns	2% of p-p V	Referenced to a 067-06681-01 tunnel diode pulser measured in a 1 GHz system into a 50 ohm load. The 0% reference point is 35 ns after the 50% point of the first transition.
After 10 ns	1% of p-p V	
Flatness	<= 1%	After 10 ns, referenced to a 067-0681-01 Tunnel Diode pulser measured in a 1 GHz system into 50 ohm load.

SECTION 2
OPERATOR INSTRUCTIONS

2.1 Installation and Removal

The 067-1094-99 PULSE GENERATOR is designed to operate in any plug-in compartment of TEKTRONIX TM-5000 mainframes. The TM5000 should be turned off before installation or removal of the plug-in. To install the 067-1094-99 into a plug-in compartment, push the plug-in in until it is seated flush against the front panel. To remove, pull the release latch to disengage the plug-in. Continue to pull the release latch to remove the plug-in from the mainframe. Connecting and disconnecting SMA connectors is implied.

2.2 Functional Check

Equipment: TDR system
7S12
S-6
S-53
7K mainframe
40 dB X100 attenuator
DMM
485 scope

Verify that the 25 volt p-p pulse is within specifications when the output is terminated into 50 ohms.

SECTION 3
THEORY OF OPERATION

3.1 Block Diagram Overview

The Pulse Generator has the following major blocks: Clock and Pretrigger, Variable Delay and Strobe Generator, Output Pulse and Regulator, Charge Line, and Power Supply. See the Block Diagram In Section 6.

The Clock and Pretrigger determine the repetition rate and generate a pretrigger for an oscilloscope or other instrumentation. The Output Pulse Generator and Regulator together with the 50 ohm Charge Line produce the output pulse, and determine its polarity and amplitude. The Charge Line determines the pulse length.

3.2 Circuit Description

3.2.1 Clock and Pretrigger

The Schmitt trigger, Q30 and Q35, together with Q45 form a Schmitt Oscillator that produces a low duty cycle, positive going pulse at the collector of Q30. The repetition rate (about 50 kHz) is determined by Q40, a 0.8 mA current source and the factory selected capacitor in its collector (typically 10 nF). A positive ramp (+2 V, 18 usec risetime and a 0.5 usecond fall) is supplied to the base of Q35 turning it off when the base goes more positive than the base of Q30. The voltage step at the collector of Q30 turns on Q45 discharging the collector capacitor of Q40 and resetting Q30 and Q35. A 0.5 usecond, 3 volt pulse also appears at the emitter of Q45 to drive a second Schmitt trigger, Q50 and Q55.

The collector circuit of Q55 supplies a nominal +0.2 volt, 0.5 usecond, positive pretrigger pulse into 50 ohms at J55.

3.2.2 Variable Delay

The positive going pretrigger pulse (1.25 volt, 0.5 usec) turns off Q60 and Q65. This allows the 68 pF capacitor in the collector of current source Q70 to start charging in a negative direction. When the voltage becomes negative enough to turn on the 151-0457-00 Schottky diode in the emitter of Q75, the current from Q70 is switched to Q75. A Pulse is coupled from Q75 to the base of Q80 through the transformer, turning on Q80. The Variable Delay pot (optional, not used in MPTS) in the base of Q75 varies the voltage where Q75 turns on and, therefore, the time after the pretrigger pulse.

The baseline of the pretrigger pulse is at zero volts. This allows Q60 to conduct which turns on Q65 discharging the 68 pF capacitor. The two 152-0141-02 diodes and 152-0457-00 diode keeps Q65 from saturating and ensures a fast turn off.

3.2.3 Strobe Generator

Q80 is biased to operate in the avalanche mode. The emitter is at -16 volts while the collector varies from +100 to +124. It is fed from Q95 and Q90 which form a power supply from the +150 unregulated. The voltage of this power supply is varied by the front panel Amplitude Control via the 22K resistor in the emitter of Q90. The reason for this is explained under the next heading.

Q80 will avalanche when a pulse forward biases its base emitter junction producing a 1 nsec rise, 80 volt pulse across R100 and R200.

This pulse is produced by Q80 switching the 22 pF capacitor at its emitter in series with R100 and the 51 ohm resistor connected to the collector. A portion of this pulse is supplied via R100 and a transformer to the base of Q100, the positive output switching transistor. This pulse also is supplied via R200 and another transformer to the base of Q200, the negative output switching transistor.

3.2.4 Positive Output Pulse Generator and Regulator

Q100 is biased to operate as an avalanche transistor switch which discharges a 50 ohm coaxial cable (charge line) into 50 ohm load when conducting.

The output pulse amplitude is regulated, and varied in amplitude, by controlling the voltage at the collector of Q100 and thus, the voltage that is on the charge line.

The output pulse is peak detected and applied to one gate of Q135. This is compared with a voltage connected to the other gate from the collector of Q150. The amplifier consisting of Q's 105, 110, 115, 120, 125, 130, 135, 145 and 150

will adjust the voltage at the collector of Q100 until the Output Pulse is the same as the reference voltage obtained from Q150.

Varying the amplitude control at the negative input of U40 will vary the voltage at the collector of Q150 from 21.5 volts to 25 volts with a 169k feedback resistor. This will vary the output pulse voltage by the same amount. The 5k amplitude control adjusts both the positive and negative pulse amplitudes. R40 adjusts the maximum voltage limit of the amplitude control. R30 matches the negative pulse to the positive pulse.

Varying the voltage on the collector of Q100, and Q200 to control the Output changes the voltage needed to trigger Q100, and Q200 into conduction. This has the undesirable effect of changing the front corner of the Output Pulse. The variable output voltage is fed to the emitter of Q90 via the 22k to reduce the voltage to Q80 and thus, the pulse amplitude to Q100 when the voltage is low. This tends to minimize the change in the front corner.

The 8.2 volt Zener from the base of Q105 limits the current to approximately 8 mA. The 62 volt Zener and 152-0241-00 diode to the gate of Q145 limits the voltage to + 85 volts at the collector of Q100 in the absence of an output pulse. If the diodes are absent, the voltage can go to the unregulated voltage, + 150V at high line.

CAUTION: THESE HIGH VOLTAGES ARE PRESENT ON THE CHARGE LINE.

3.2.5 Negative Output Pulse Generator and Regulator

Negative pulses are not used on M.P.T.S.

If the line going to the base of Q180 is grounded or pulled below +1.5 Volts, the amplifier consisting Q180, Q175, Q165, and Q170 cause enough current to flow through relay K1 to switch it to Q200. K1 connects the output to Q100 for positive pulses and Q200 for negative pulses. The charge line is switched with the same relay.

Both Q100 and Q200 are selected for a break down voltage of 76 to 82 VDC. Both are biased to operate as avalanche transistor switches which discharge the 50 ohm coaxial cable (charge line) into a 50 ohm load when conducting.

The output pulse amplitude is regulated, and varied in amplitude, by controlling the voltage at the base of Q200 and thus, the voltage that is on the charge line.

The output pulse is peak detected and applied to one gate of Q185. This is compared with a voltage connected to the other gate from the collector of Q155. The amplifier consisting of Q's 155, 185, 190, 195, 205, 210, and 215 will adjust the voltage at the base of Q200 until the output pulse is the same as the reference voltage obtained from Q155.

The 8.2 volt Zener from the base of Q210 limits the current to approximately 8 mA. The 62 volt Zener and 152-0241-00 diode to the gate of Q185 limits the voltage to - 85 volts at the base of Q200 in the absence of an output pulse. If the diodes are absent, the voltage can go to the unregulated voltage, - 150 volts at high line.

CAUTION: THESE HIGH VOLTAGES ARE PRESENT ON THE CHARGE LINE.

3.2.6 Charge Line

The Charge line can be any good quality, 50 ohm coaxial cable. The pulse width is twice the electrical length of the line. Minimum aberrations occur when the charge line is one piece with one end connected directly to the EC board. This configuration is used on MPTS. If the charge line is inside the module, there is a practical limit on the size of the line, and, therefore, on the pulse width.

The charge line, Q100, the attenuator, and the cabling, all tend to roll off the pulse. C100 through C103 with appropriate resistors, are in parallel with the charge line and add peaking at different times from the front corner. The longest one is 5 to 40 nsec back from the front corner, and thus puts a limit on the length of lossy line that can be made flat. Fourteen feet of 0.250 inch semi-rigid can be coiled up inside a one-wide TM500 module. This gives a pulse width of 40 ns and can be made quite flat.

Air lines are the preferred charge line. They can produce longer, fairly flat pulses. Unfortunately they are large and must be connected outside the module with short cables. And all cables and connectors must be carefully selected and matched to the Pulse Generator, or aberrations will be the inevitable result.

Furthermore, unless Q100 is selected, pulses longer than 100 nsec may cause a "glitch" and roll off at the top of the falling edge of the pulse.

3.2.7 Power Supplies

The + 150 unregulated voltage is made by stacking some of the TM500 AC windings and then doubling the result. The voltage is + 150v with 118v AC in a TM503 module with the line selector at high line. Other modules will give different voltages.

The plus and minus 18 volt supplies are conventional series pass with the reference and adjustment in the plus 18v. The adjustment should be made to adjust the minus 18 to - 18.00 volts as this will make the Variable Amplitude range proper.

SECTION 4
CALIBRATION

4.1 Test Equipment Required

1. Variac, 60 Hz capable of supplying a TM500 main frame with 100 to 130 VAC.
2. DVM (Digital Voltmeter)
3. Test Oscilloscope, bandwidth ≥ 100 MHz. (A 7S12, or a 2465 tuned very flat is acceptable).
4. A 067-0681-01 Tunnel Diode pulser.
5. TM 500 main frame.
6. Extender cable 067-0645-01 (optional).
7. Two 10X, BNC attenuators.
8. A special 6 foot precision coaxial cable, with a BNC connector on one end and an SMA connector on the other. (Or two 012-0482-00 connected together).

4.2 Preliminary Inspection and Connections

1. Inspect the circuit board for good workmanship, missing parts etc.
2. Center R10.
3. Set R100 fully counterclockwise.
4. Plug the Pulse Generator into a TM500 main frame, or connect it with a TM500 extender cable 067-0645-01.

4.3 Power Supply Voltages

CAUTION: PLUS AND MINUS 150 VOLTS DC ARE PRESENT ON THIS UNIT. THESE ARE DANGEROUSLY HIGH VOLTAGES. TAKE PROPER PRECAUTIONS.

1. Connect a DVM from the -18 test point to GND. Adjust R10 for -18.00 volts. Even though R10 is in the +18 volt regulator it will adjust the -18 volt power supply, because it sets most of the biases.
2. Measure the +18 volt supply. It should be +18.00 \pm 0.18
3. Connect the DVM to the +25 volt test point. Vary the amplitude control, R15. The CW position should produce a voltage between 22 and 23 volts, and the CCW position should produce a voltage between 25.5 and 26.3 volts.
4. The 150 volt supply should be:

approx. +130 at an input line voltage of 100 volts.

approx. +175 at an input line voltage of 130 volts.

The above voltages will vary somewhat depending on which TM500 is used and the settings on the line selector block.

4.4 Power Supply Ripple

Set the test scope to 5 milliseconds/division and trigger on the line source. Connect the vertical amplifier to the supplies listed below and measure the 120 Hz ripple while varying the line voltage from 100 volts to 130 volts. The point where the supplies go out of regulation will vary depending on the TM500 module and the line selector settings. The amplitude in the regulated region should be:

SUPPLY	GAIN SETTING (AC COUPLED)	DISPLAY AMPLITUDE
+150 V	1 V/Division	2.5 V approx.
+18 V	5 mV/Division	\leq 1 mV
-18 V	5 mV/Division	\leq 1 mV
+25 V	5 mV/Division	\leq 2 mV
Q115 Collector	5 mV/Division	Neg. 8 V pulses typical

4.5 Bias Adjustment

NOTE: Each time a new Pulse Generator is installed in a M.P.T.S. it is necessary to re-verify the pulse response. The pulse response is system dependent.

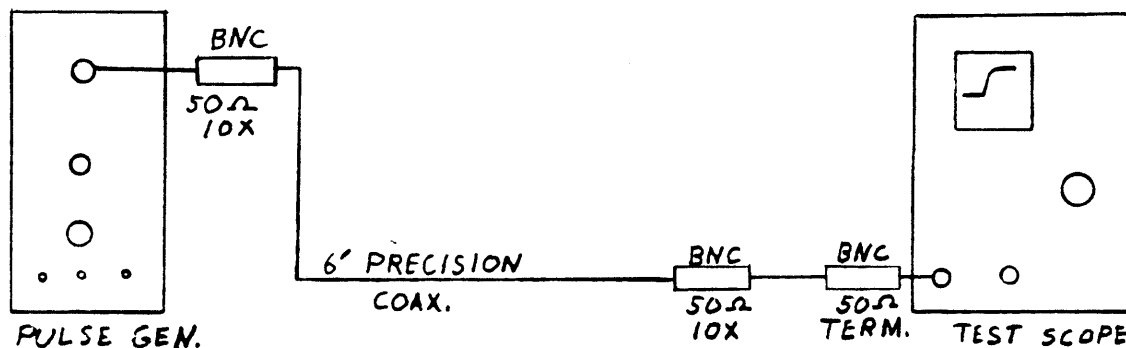

Figure 4-1: Bias Adj. Setup

Connect a test oscilloscope with a bandwidth of ≥ 100 MHz to the Pulse Generator output jack making sure the two 10X BNC attenuators, the 6 foot precision coaxial cable, and the BNC 50 ohm termination shown in Figure 4-1 are connected as shown. One attenuator is connected directly to the Pulse Generator. The termination is connected directly to the Test Scope input, and the other attenuator is connected directly to it. The 6 foot precision coaxial cable is the only cable to be used in this line. This cable length will simulate the path length found in the M.P.T.S.

Set the test scope to 5 mV/division, 50 nanoseconds/division, DC coupled. Adjust the triggering and position controls for a 5 division display centered on the graticule.

Turn R100 CW until the display grows dim and observe the rise on the front corner. Turn R100 CCW until the front corner just stops moving. Adjusting R100 beyond this point may reduce the risetime.

Adjust the Amplitude control (R155) from the full CCW to full CW and watch the corner. If the corner moves, adjust R100 slightly CW and try again. The correct adjustment will be approximately 8 o'clock on the pot.

4.6 Compensating Capacitors Adjustment

The compensating capacitors are adjusted until the pulse is well within specifications. If necessary, the values of R102 through R105 and R202 through R205 also may be changed. The values given on the schematic are good ones with which to start out. Since the adjustments are somewhat interdependent, the following suggestions may need modification in practice.

The compensating capacitor, C103 is adjusted while observing with a real time scope with the vertical amplifier tuned very flat using the PG506.

The high frequency compensating capacitor, C102 may be adjusted with a 7S12 and a S6 head, or a 2465 tuned very flat.

The board C in series with R105 may be sufficient to compensate the corner. If needed, a 0.3 to 1.2 pF capacitor (281-0138-00) may be soldered into the board with R105 soldered directly to it to provide adjustment.

CAUTION: THE INPUT TO THE SAMPLING OSCILLOSCOPES MUST NOT EXCEED 5 VOLTS OR THE INPUT BRIDGE DIODES WILL BE DESTROYED. ALWAYS KEEP A X10, 50 OHM ATTENUATOR ON THE CABLE FROM THE PULSE GENERATOR.

Connect the Pulse Generator through a X10 attenuator and the precision cable to CH. 1 of a 7S14 sampling plug-in. Set the controls as follows:

CH. 1 INPUT: 50 mV/division	+ SLOPE: in
VERTICAL MODE: CH. 1	REP: in
DELAYING T/D (inner knob): 10 ns	DELAY TIME MULT: set to zero
DELAYED T/D (out knob): 5 ns	TRIGGER CONTROL: Approx. 2 o'clock
SWEEP MODE: out	SCAN: mid range
TRIGGER SELECTOR: CH. 1	DELAY ZERO: CCW
HF SYNC: out	
AUTO TRIG: out	

The calibration and flatness of the 7S12 should be checked with a 067-0681-01 tunnel diode pulser and a 2X, 50 ohm attenuator before continuing the calibration.

Adjust CH. 1 offset and trigger controls as necessary to obtain a trace on the screen. Note the slow roll off of the waveform and adjust C102 to continue the slope of the roll off. Do not spike the corner. If C100 needs adjustment, or Q100 has been changed, a S-6 must be used as the 7S14 is not fast enough.

Apply side cover with access holes in it. Reconnect the Pulse Generator to the test scope and use C103 and R100 to adjust for best overall flatness while insuring that the corner does not change with the variable amplitude. It is better to have the corner down slightly (rather than up) as this will make the bias more stable with temperature.

On the schematic, additional R and C combinations are shown. These may be needed to give the desired pulse response.

The negative pulse is compensated in much the same way.

4.7 Frequency Check

If the distance between pulses is close to 20 microseconds, the frequency will be close to the desired 50kHz. On M.P.T.S. this is not critical.

4.8 Rise Time Measurement

Connect the Pulse Generator with the X10 attenuator to a S-2 or S-6 head in an appropriated sampling oscilloscope. Set scope to 200 ps/division and adjust the variable amplitude control for exactly 5 divisions. Measure the 10% to 90% rise time. It should be ≤ 400 ps (300 to 350 ps is typical).

4.9 Pre-trigger Check

Connect the PRETRIGGER OUTPUT to CH 1 of the test scope with a BNC cable and a 50 ohm termination. Trigger the test scope on CH 1 only. The pulse amplitude should be about 0.2 volts and the duration should be approximately 0.5 microseconds.

SECTION 5
DIAGNOSTICS AND REPAIR SUGGESTIONS

5.1 Equipment Required

TDR system

7S12
S-6
S-53
7K mainframe
40 dB X100 attenuator
DMM
485 scope

5.2 Technique

CAUTION: PLUS AND MINUS 150 VOLTS DC ARE PRESENT ON THIS UNIT. THESE ARE DANGEROUSLY HIGH VOLTAGES. TAKE PROPER PRECAUTIONS.

One of the best methods of trouble shooting this instrument is to compare ohmmeter readings with those on a known good unit. Because + and - 150 VDC is all over the unit, good components may become defective if the power is turned on when a defective component, or an incorrectly replaced component, is present. Power up, only after the ohmmeter readings check out. This will save time and energy.



An unexpected error occurred in processing this page.

Please retry importing this document.

SECTION 6
REPLACEABLE PARTS LISTS

6.1 Parts ordering information

Replacement parts are available from or through your local Tektronix Inc. Field Office or representative.

It is important, when ordering parts, to include the following information in your order: Part number, instrument type or number, serial number, and modification number if applicable.

Change information, if any, is located at the rear of this manual.

6.2 Component Number System

A list of assemblies can be found at the beginning of the Electrical Parts List. The assemblies are listed in numerical order. When the complete component number is known, this list will identify the assembly in which the part is located.

A numbering method has been used to identify assemblies, subassemblies, and parts. For example the Component Number:

A1C14Ø

consists of Assembly Number, A1 followed by Circuit Number, C14Ø. Read: Capacitor 14Ø of Assembly A1.

Only the circuit number will appear on the diagrams and circuit board illustrations. Each diagram is marked with the assembly number.

The Electrical Parts List is divided and arranged by assemblies in numerical sequence (e.g., assembly A1 with its subassemblies and parts, precedes assembly A2 with its subassemblies and parts).

REPLACEABLE PARTS LISTS
M. P. T. S. FASTRISE PULSE GENERATOR

Chassis-mounted parts have no assembly number prefix and are located at the end of the Electrical Parts List.

REPLACEABLE ELECTRICAL PARTS 067-1094-99

COMPONENT NUMBER	PART NUMBER	DESCRIPTION	NOTES
A1	670-7831-00	Pulse Gen. Board Assy	
	388-8171-00	RAW BOARD	
	(G1228XB)	Film Number	
C001	290-0569-00	CAP 50 uF 250V	
C002	290-0569-00	CAP 50 uF 250V	
C003	290-0569-00	CAP 50 uF 250V	
C004	290-0569-00	CAP 50 uF 250V	
C010	281-0773-00	CAP 0.01 uF	
C011	281-0775-00	CAP 0.1 uF	
C012	281-0775-00	CAP 0.1 uF	
C013	281-0775-00	CAP 0.1 uF	
C014	290-0517-00	CAP 6.8 uF 35V	
C015	281-0775-00	CAP 0.1 uF	
C020	285-0598-00	CAP 0.01 uF 100v	
C021	281-0775-00	CAP 0.1 uF	
C022	281-0775-00	CAP 0.1 uF	
C035	285-0598-00	CAP 0.01 uF	
C036	281-0797-00	CAP 15 pF	
C040	281-0775-00	CAP 0.1 uF	
C050	281-0814-00	CAP 100 pF	
C051	281-0814-00	CAP 100 pF	
C056	281-0775-00	CAP 0.1 uF	
C057	290-0517-00	CAP 6.8 uF 35V	
C065	281-0775-00	CAP 0.1 uF	
C066	281-0785-00	CAP 68 pF	
C075	281-0786-00	CAP 150 pF	
C076	281-0788-00	CAP 470 pF	
C080	281-0656-00	CAP 22 pF	
C081	281-0775-00	CAP 0.1 uF	
C082	281-0773-00	CAP 0.01 uF	
C091	281-0788-00	CAP 470 pF	
C100	281-0213-00	VAR. CAP 0.8-3.5pF	(Or 281-0214-00) *
C101	283-0208-00	DISCAP 0.22uF 200V	
C102	281-0578-00	CAP 18 pF 500V	Select value for best pulse*
C103	281-0151-00	VAR. CAP 1-3pf	
C111	281-0797-00	CAP 15 pF	
C120	281-0775-00	CAP 0.1 uF	
C121	290-0517-00	CAP 6.8 uF 35V	

REPLACEABLE ELECTRICAL PARTS 067-1094-99

COMPONENT NUMBER	PART NUMBER	DESCRIPTION	NOTES
C125	281-0814-00	CAP 100 pF	
C126	281-0788-00	CAP 470 pF	
C131	281-0788-00	CAP 470 pF	
C150	281-0773-00	CAP 0.01uF	
C175	281-0775-00	CAP 0.1 uF	
C181	281-0814-00	CAP 100 pF	
C182	281-0773-00	CAP 0.01uF	
C184	281-0775-00	CAP 0.1 uF	
C183	290-0517-00	CAP 6.8 uF 35V	
C185	281-0797-00	CAP 15 pF	
C190	281-0788-00	CAP 470 pF	
C200	281-0214-00	VAR. CAP 0.6-3pF	Usually omitted.
C201	281-0578-00	CAP 5.6 pF	Value is selected.
C202	281-0213-00	CAP 0.8-3.5 pF	
C203	281-0214-00	CAP 0.6-3 pF	Usually not needed
C205	281-0788-00	CAP 470 pF	
C210	283-0208-00	DISCAP 0.22uF 200V	
CR001	152-0107-00	DIODE	
CR002	152-0107-00	DIODE	
CR003	152-0107-00	DIODE	
CR004	152-0107-00	DIODE	
CR010	152-0066-00	DIODE	
CR020	152-0066-00	DIODE	
CR035	152-0141-02	DIODE	
CR040	152-0141-02	DIODE	
CR060	152-0141-02	DIODE	
CR061	152-0141-02	DIODE	
CR065	152-0141-02	DIODE	
CR066	152-0141-02	DIODE	
CR067	152-0457-00	DIODE, SCHOTTKY	
CR070	152-0141-02	DIODE	
CR075	152-0457-00	DIODE, SCHOTTKY	
CR080	152-0141-02	DIODE	
CR111	152-0323-01	DIODE	
CR125	152-0323-01	DIODE	
CR165	152-0141-02	DIODE	
CR181	152-0323-01	DIODE	
CR210	152-0141-02	DIODE	
CR215	152-0323-01	DIODE	
J055			Pretrigger. (J065 unused)

REPLACEABLE ELECTRICAL PARTS 067-1094-99

COMPONENT NUMBER	PART NUMBER	DESCRIPTION	NOTES
J100			Output
J180			POL, polarity control
J200			Charge line
K001	xxx-xxxx-xx	Relay, 26.5VDC, 700 Ohms, Cont. 2A. (J8206C 02289 223)	HI-G Co. Inc. J 2k-4730,209L M 39016/6-209L
Q010	151-0190-00	TRANSISTOR	
Q020	151-0188-00	TRANSISTOR	
Q030	151-0188-00	TRANSISTOR	
Q035	151-0188-00	TRANSISTOR	
Q040	151-0188-00	TRANSISTOR	
Q045	151-0190-00	TRANSISTOR	
Q050	151-0369-00	TRANSISTOR	
Q055	151-0369-00	TRANSISTOR	
Q060	151-0190-00	TRANSISTOR	
Q065	151-0188-00	TRANSISTOR	
Q070	151-0302-00	TRANSISTOR	
Q075	151-0190-00	TRANSISTOR	
Q080	151-0302-00	TRANSISTOR	
Q090	151-0347-01	TRANSISTOR	
Q095	151-0350-00	TRANSISTOR	
Q100	151-0108-01	TRANSISTOR	Select from Motorola 2N2501 (SM1527) for 78V=> B(subCB0) <=85V
Q105	151-0311-00	TRANSISTOR	
Q110	151-0350-00	TRANSISTOR	
Q115	151-0350-00	TRANSISTOR	
Q120	151-0347-01	TRANSISTOR	
Q125	151-0347-01	TRANSISTOR	
Q130	151-0347-01	TRANSISTOR	
Q135	151-1041-00	TRANSISTOR	
Q140	151-0347-01	TRANSISTOR	
Q145	151-0350-00	TRANSISTOR	
Q150	151-0347-01	TRANSISTOR	
Q155	151-0350-00	TRANSISTOR	
Q160	151-0350-00	TRANSISTOR	
Q165	151-0188-00	TRANSISTOR	
Q170	151-0190-00	TRANSISTOR	
Q175	151-0188-00	TRANSISTOR	
Q180	151-0188-00	TRANSISTOR	
Q185	151-1041-00	TRANSISTOR	

REPLACEABLE ELECTRICAL PARTS 067-1094-99

COMPONENT NUMBER	PART NUMBER	DESCRIPTION	NOTES
Q190	151-0350-00	TRANSISTOR	
Q195	151-0350-00	TRANSISTOR	
Q200	151-0108-01	TRANSISTOR	Select from Motorola 2N2501 (SM1527) for 78V=> B(subCB0) <=85V
Q205	151-0347-01	TRANSISTOR	
Q210	151-0311-00	TRANSISTOR	
Q215	151-0347-01	TRANSISTOR	
R001	315-0474-00	RES 470k	
R002	315-0474-00	RES 470k	
R003	315-0474-00	RES 470k	
R004	315-0474-00	RES 470k	
R010	311-1225-00	VAR RES 1K	
R011	315-0432-00	RES 4.3k	
R012	321-0201-00	RES 1.21k	
R013	315-0182-00	RES 1.8k	
R014	321-0277-00	RES 7.50k	
R015	321-0277-00	RES 7.50k	
R016	307-0112-00	RES 4.3ohm	5%
R017	315-0182-00	RES 1.8k	
R020	321-0816-00	RES 5k	
R021	321-0603-07	RES 15k 0.1%	
R022	321-0603-07	RES 15k 0.1%	
R023	315-0432-00	RES 4.3k	
R024	315-0182-00	RES 1.8k	
R025	315-0182-00	RES 1.8k	
R026	321-0603-07	RES 15k 0.1%	
R027	321-0603-07	RES 15k 0.1%	
R030	311-1035-00	VAR RES (tweek) 50k	
R031	321-0407-00	RES 169k	
R032	315-0105-00	RES 1 Meg	
R033	315-0822-00	RES 8.2k	
R035	315-0822-00	RES 8.2k	
R036	315-0152-00	RESISTOR 1.5k	
R037	315-0332-00	RES 3.3k	
R038	315-0471-00	RES 470 ohm	
R039	315-0471-00	RES 470 ohm	
R040	311-1035-00	VAR RES (tweek) 50k	
R041	321-0277-00	RES 7.50k	
R042	321-0277-00	RES 7.50k	
R043	315-0432-00	RES 4.3k	
R044	315-0222-00	RES 2.2k	

REPLACEABLE ELECTRICAL PARTS 067-1094-99

COMPONENT NUMBER	PART NUMBER	DESCRIPTION	NOTES
R045	315-0101-00	RES 100 ohm	
R050	315-0682-00	RES 6.8k	
R051	315-0621-00	RES 620 ohm	
R052	317-0561-00	RES 560 ohm, 1/8W	
R053	315-0560-00	RES 56 ohm	
R055	315-0221-00	RES 220 ohm	
R056	303-0271-00	RES 270 ohm 1w 5%	
R057	315-0682-00	RES 6.8k	
R058	315-0620-00	RES 62 ohm	
R059	315-0620-00	RES 62 ohm	
R060	315-0332-00	RES 3.3k	
R065	315-0561-00	RES 560 ohm	
R066	315-0512-00	RES 5.1k	
R067	315-0681-00	RES 680 ohm	
R070	315-0681-00	RES 680 ohm	
R071	315-0474-00	RES 470k	
R072	315-0512-00	RES 5.1k	
R073	315-0332-00	RES 3.3k	
R075	315-0473-00	RES 47k	
R076	315-0101-00	RES 100 ohm	
R080	317-0510-00	RES 5.1 1/8 W	
R081	317-0510-00	RES 5.1 1/8 W	
R082	315-0202-00	RES 2k	AB ONLY
R083	315-0472-03	RES 4.4k	AB only
R084	315-0391-00	RES 390 ohm	
R085	307-0103-00	RES 2.7ohm 5%	
R091	315-0753-00	RES 75k	
R092	315-0223-00	RES 22k	
R093	315-0622-00	RES 6.2k	
R095	315-0682-00	RES 6.8k	
R096	315-0103-00	RES 10k	
R100	311-1258-00	VAR RES 50 ohm	
R101	315-0472-03	RES 4.7k	AB only
R102	317-0471-00	RES 470 ohm 1/8 W	Starting values, select
R103	317-0561-00	RES 560 ohm 1/8 W	for best shape pulse *
R104	317-0181-00	RES 180 ohm 1/8 W	" *
R105	317-0100-00	RES 10 ohm 1/8 W	" *
R106	317-0510-00	RES 51 ohm	
R107	317-0751-00	RES 750 ohm	
R108	317-0751-00	RES 750 ohm	
R109	315-0102-00	RES 1k	

REPLACEABLE ELECTRICAL PARTS 067-1094-99

COMPONENT NUMBER	PART NUMBER	DESCRIPTION	NOTES
R110	315-0184-00	RES 180k	
R111	315-0105-00	RES 1 Meg	
R112	315-0471-00	RES 470 ohm	
R113	315-0474-00	RES 470k	
R114	315-0473-00	RES 47k	
R115	315-0102-00	RES 1k	
R116	315-0474-00	RES 470k	
R117	315-0332-00	RES 3.3k	
R121	315-0103-00	RES 10k	
R125	315-0335-00	RES 3.3 Mohm	
R126	317-0392-00	RES 3.9k 1/8W	
R127	315-0105-00	RES 1 Meg	
R128	315-0332-00	RES 3.3k	
R131	315-0683-00	RES 68k	
R132	315-0473-00	RES 47k	
R133	315-0332-00	RES 3.3k	
R135	315-0104-00	RES 100k	
R136	315-0103-00	RES 10k	
R140	315-0753-00	RES 75k	
R145	315-0273-00	RES 27k	
R146	315-0683-00	RES 68k	
R150	321-0407-00	RES 169k	
R151	321-0775-00	RES 45k	
R152	315-0105-00	RES 1 Meg	
R153	315-0103-00	RES 10k	
R154	315-0103-00	RES 10k	
R155	311-1332-00	VAR AMP 5k POT	
R156	315-0184-00	RES 180k	
R157	315-0273-00	RES 27k	
R165	315-0133-00	RES 13k	
R166	315-0104-00	RES 100k	
R167	315-0273-00	RES 27k	
R170	315-0103-00	RES 10k	
R171	315-0133-00	RES 13K	
R175	315-0473-00	RES 47k	
R176	315-0104-00	RES 100k	
R177	315-0103-00	RES 10k	
R180	315-0332-00	RES 3.3k	
R181	315-0335-00	RES 3.3 Mohm	
R182	317-0392-00	RES 3.9k 1/8W	
R183	315-0332-00	RES 3.3k	

REPLACEABLE ELECTRICAL PARTS 067-1094-99

COMPONENT NUMBER	PART NUMBER	DESCRIPTION	NOTES
R184	315-0105-00	RES 1 Meg	
R185	321-0407-00	RES 169k	
R186	315-0332-00	RES 3.3k	
R187	315-0104-00	RES 100k	
R188	315-0273-00	RES 27k	
R191	315-0223-00	RES 22k	
R192	315-0103-00	RES 10k	
R193	315-0102-00	RES 1k	
R194	315-0103-00	RES 10k	
R200	311-1258-00	VAR RES 50 ohm	
R201	317-0751-00	RES 750 ohm	
R202		RES 360 1/8 W	Starting values. Select for best pulse shape
R203		RES 110 1/8 W	
R204		RES 110 1/8 W	
R205		RES 10 1/8 W	
R206	317-0751-00	RES 750 ohm	
R207	315-0472-03	RES 4.7k	AB only
R208	317-0510-00	RES 51 ohm	
R209	315-0473-00	RES 47k	
R210	315-0102-00	RES 1k	
R211	315-0104-00	RES 100k	
R212	315-0222-00	RES 2.2k	
R213	315-0332-00	RES 3.3k	
R214	315-0184-00	RES 180k	
R215	315-0103-00	RES 10k	
R216	315-0471-00	RES 470 ohm	
R217	315-0104-00	RES 100k	
R218	315-0473-00	RES 47k	
R219	315-0471-00	RES 470 ohm	
T080	120-0550-00	TRANSFORMER	
T100	120-0544-00	TRANSFORMER	
T200	120-0544-00	TRANSFORMER	
U010	156-0067-00	IC 741 IC	
U020	156-0067-00	IC 741 IC	
U030	156-0067-00	IC 741 IC	
U040	156-0067-00	IC 741 IC	
VR010	152-0212-00	DIODE, Zener 9V	
VR011	152-0149-00	DIODE	
VR020	152-0149-00	DIODE	
VR105	152-0217-00	DIODE, ZENER 8.2V	

REPLACEABLE ELECTRICAL PARTS 067-1094-99

COMPONENT NUMBER	PART NUMBER	DESCRIPTION	NOTES
VR111	152-0285-00	DIODE, ZENER 62V	
VR120	152-0241-00	DIODE, ZENER 33V	
VR145	152-0285-00	DIODE, ZENER 62V	
VR205	152-0217-00	DIODE, ZENER 8.2V	
VR215	152-0285-00	DIODE, ZENER 62V	
W001	131-0566-00	0 ohm	
W002	131-0566-00	0 ohm	

REPLACEABLE MECHANICAL PARTS 067-1094-99

COMPONENT NUMBER	PART NUMBER	QTY PER	DESCRIPTION	NOTES
	105-0718-00	1	LATCH RELEASE BAR	
	105-0719-00	1	RETAINING LATCH	
	131-0608-00	4	SQ PIN	Mounts on Board
	131-0663-00	1	SCREW ON RECEPTACLE	
	131-0774-00	1	SMA CONNECTOR	
	131-1003-00	1	PELTOLA RECEPTACLE	Mounts on Board
	131-1315-00	1	BNC	
	131-2117-00	1	SMA CONNECTOR	
	131-2623-00	4	BERG CONN.	*Part of Berg Cable Assy
	136-0252-00	10	BERG SOCKET	Mounts on Board
	136-0387-00	3	PROBE JACK	
	175-0825-00	6.5"	2 CONDUCTOR WIRE 26AWG	*Part of Berg Cable Assy
	175-1045-00	1	3 3/4" 50 ohm	CONFIGURED AS PER
	175-1045-00a		Semi-Rigid Cable	CABLE DOC.
	175-1202-00	7"	50ohm CABLE	Part of Peltola C. Assy
	200-1273-00	1	FRT PANEL SUPPT, METAL	(BLANK)
	210-0438-00	4	NUT 1-72	FNT PANEL SECURE
	210-0471-00	1	HEX THD SPACER	
	210-0774-00	2	OUTER EYELET PELTOLA	Part of Peltola C. Assy
	210-0775-00	2	INNER EYELET PELTOLA	Part of Peltola C. Assy
	211-0125-00	4	SRW 1-72 BLK	FNT PANEL SECURE
	213-0146-00	4	SRW TAPPING 6-20	BOARD SECURE
	213-0229-00	4	SRW TAPPING 6-20	FRT SUB PANEL SECURE
	213-0254-00	1	SRW TAPPING 2-32	LATCH SECURE
	214-0579-00	4	Test Point	
	337-1399-00	1	ELEC. SHIELD	SIDE COVERS
	352-0169-00	2	1X2 TERMINAL CONN	*Part of Berg Cable Assy
	358-0342-00	1	FNT PANEL BUSHING	
	366-1690-00	1	LATCH KNOB	
	386-2402-00	1	FRT SUB PANEL, PLASTIC	(BLANK)
	386-3657-01	2	PLUG-IN SUPPORT	
	426-0725-00	1	FRAME SEC.-TOP	
	426-0726-00	1	FRAME SEC.-BOTTOM	
	XXX-XXXX-XX	1	FRT PANEL	
	XXX-XXXX-XX	1	BERG-CABLE ASSEMBLY	Made of parts marked*
	XXX-XXXX-XX	1	PELTOLA CABLE ASSEM	Made of parts marked
	XXX-XXXX-XX	1	1/4" Dia, 50 ohm, 14.5'	Charge line: 14'
	XXX-XXXX-XX		Semi-Rigid Cable	gives approx 40 ns.



SECTION 7

DIAGRAMS

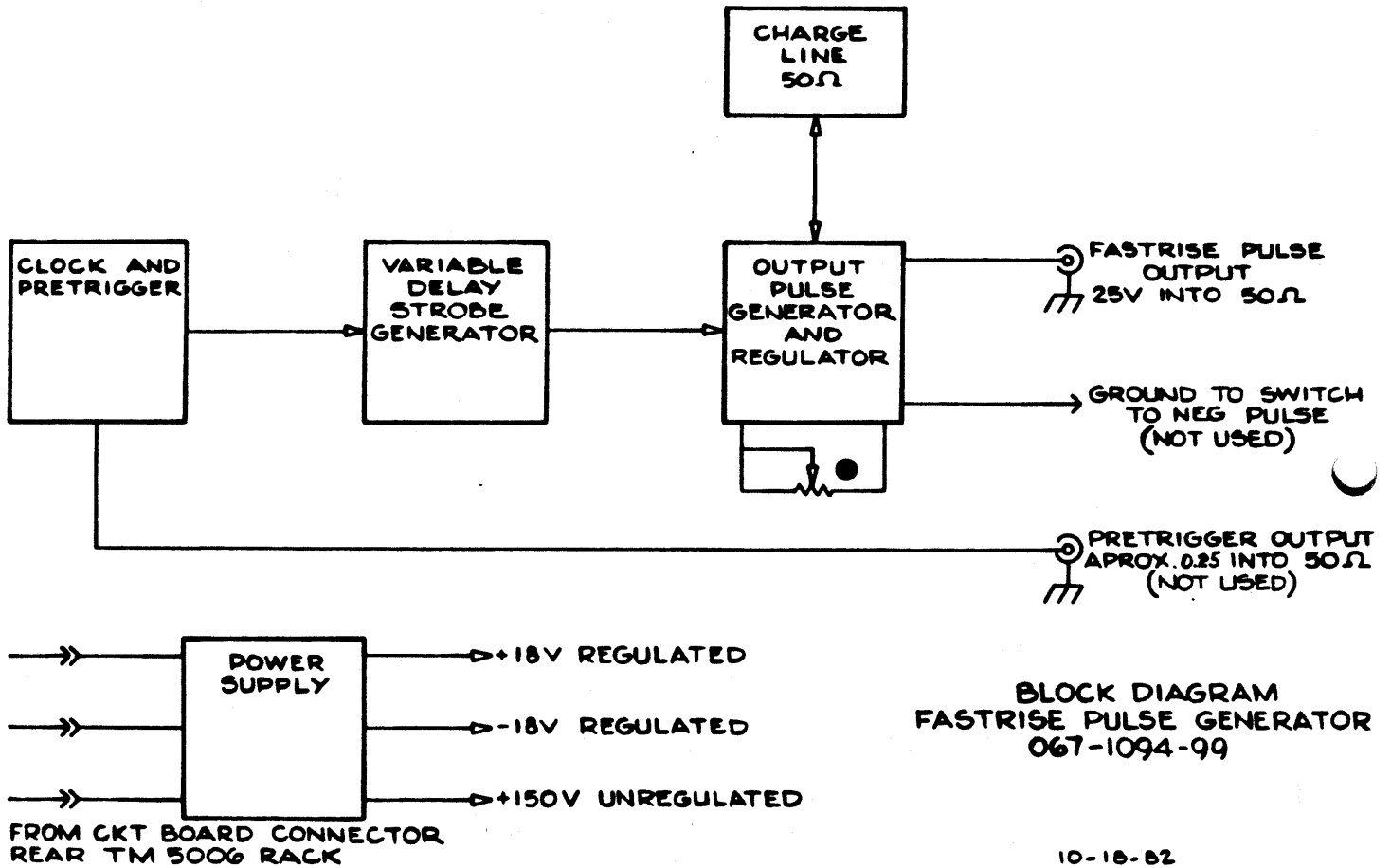

Figure 7-1: Pulse Generator Block Diagram

Figure 7-2: Pulse Generator Schematic

SECTION 8

INDEX

bias adjust	4-3
calibration	4-1
charge line	3-4
circuit board inspection	4-1
compensating capacitors	4-4
connectors	1-1
controls	1-1
diagnostics	5-1
frequency check	4-5
Indicators	1-1
Installation	2-1
negative pulse	3-3
parts list	6-1
power supplies	3-4
power supply	4-2
power supply ripple	4-2
pre-trigger	4-5
pulse height	1-1
pulse, negative	3-3
R10	4-2
removal	2-1
repair	5-1
rise time	4-5
rifetime	1-1
test equipment, calibration	4-1
theory of operation	3-1
troubleshooting	5-1

