

SECTION 1: OPERATION

FEATURES:

The 067-0711-99 CROSSHATCH/RASTER GENERATOR is a test fixture for adjusting and verifying geometry, focus, resolution, and astigmatism of Tektronix 7000 Series oscilloscopes. Provision is made for writing speed comparisons with 7000 Series storage oscilloscopes.

The displays generated by the 067-0711-99 include crosshatch, vertical raster, and horizontal raster - each comprised of either 11 or 110 lines. (See illustrations on page 1-2)

The output from the 067-0711-99 is available in many different forms. When operating in the horizontal compartment of most 7000 Series oscilloscopes, horizontal, vertical, and Z-axis signals are available through internal paths, with the vertical and Z-axis paths being switchable. When operating in any compartment, horizontal, vertical, and Z-axis signals are available through the front panel BNC connectors.

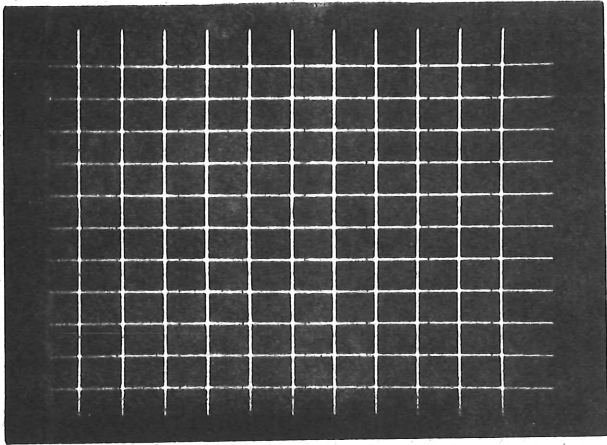

11 LINE CROSSHATCH

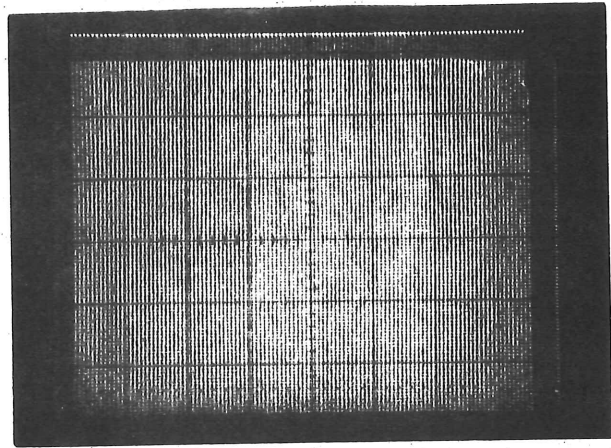

110 LINE CROSSHATCH

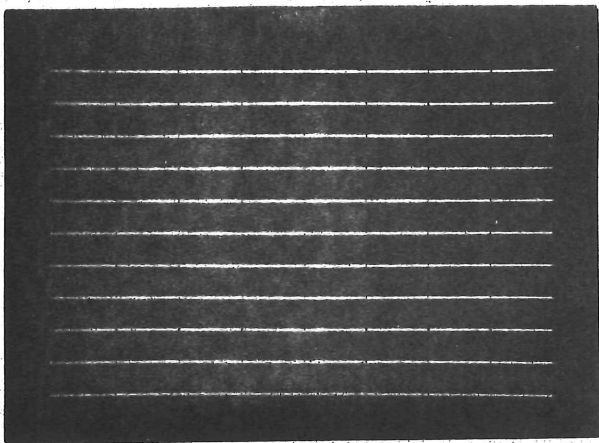

11 LINE HORIZONTAL RASTER

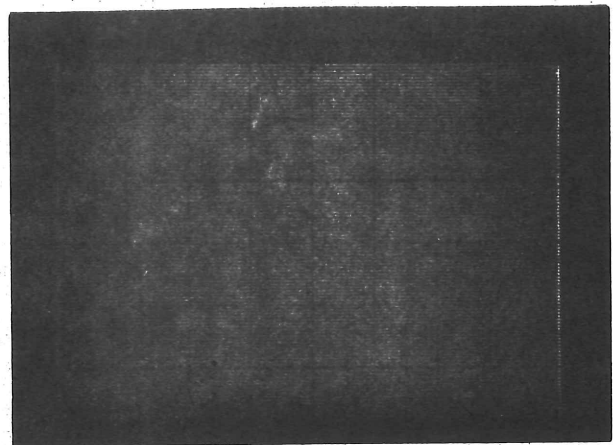

110 LINE HORIZONTAL RASTER

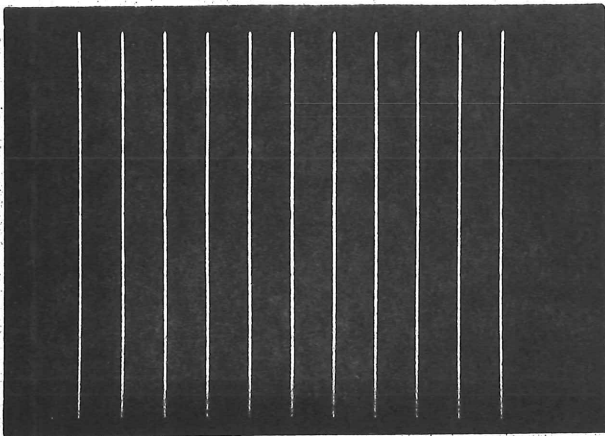

11 LINE VERTICAL RASTER

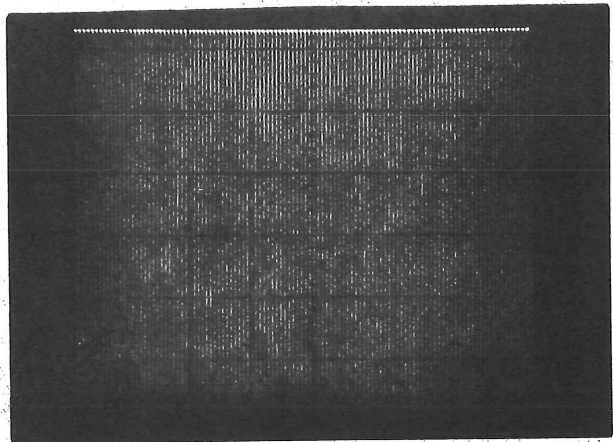

110 LINE VERTICAL RASTER

**CROSSHATCH / RASTER GENERATOR**

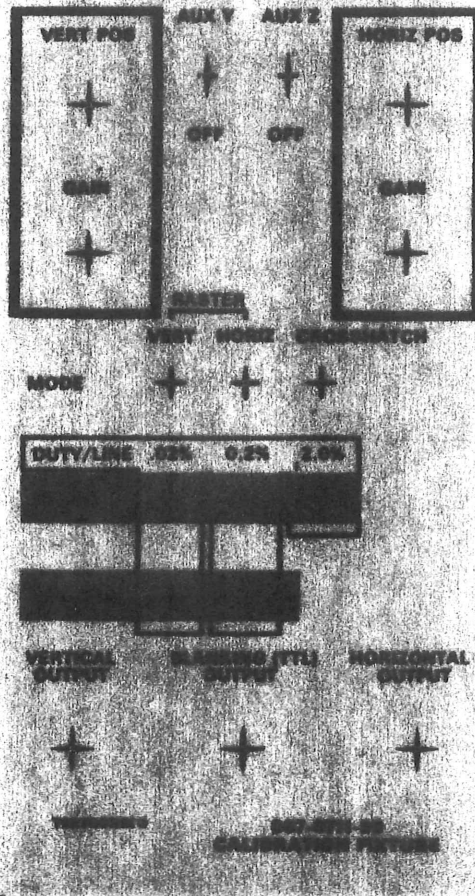

## CONTROLS AND CONNECTORS:

MODE: Three pushbutton switches that select the main display mode.

RASTER VERT. Displays vertical lines.

RASTER HORIZ. Displays horizontal lines.

CROSSHATCH. Displays both vertical and horizontal lines.

11 LINE. When any pushbutton in this row is selected, the display is 11 horizontal or vertical lines in the case of a raster display, or 11 horizontal and vertical lines in the case of a crosshatch display.

110 LINE. Same as 11 LINE only with 110 lines.

DUTY/LINE. Three columns of pushbuttons that select the duty factor per line of the display.

$$\text{Duty factor(\%)} = \frac{\text{time drawing one line}}{\text{time for complete display}} \times 100(\%)$$

Duty factors available include 0.02%, 0.2%, and 2.0%. 2.0% is not available with the 110 line display.

AUX Y. Slide switch to turn on and off vertical signal that drives oscilloscope through internal path when in the horizontal compartment of most 7000 Series oscilloscopes.

AUX Z. Slide switch to turn on and off Z-axis signal that drives oscilloscope through internal path.

VERT POS. Coarse and fine controls to position display vertically.

HORIZ POS. Coarse and fine controls to position display horizontally.

VERT GAIN. 4.5 turn control to set the size of the vertical display.

HORIZ GAIN. 4.5 turn control to set the size of the horizontal display.

VERTICAL OUTPUT. Signal output connector. Vertical output with nominal level of 100 mV/div from internally selectable source impedance of 50 or 200 ohms.

**HORIZONTAL OUTPUT.** Signal output connector. Horizontal output with nominal level of 100 mV/div from internally selectable source impedance of 50 or 200 ohms.

**BLANKING OUTPUT (TTL).** Signal output connector. Blanking output with capability of driving up to 5 normalized TTL inputs. Positive or negative phase is internally selectable.

#### SELECTING VERTICAL AND HORIZONTAL OUTPUT IMPEDANCE

Selection of the output impedance (50 or 200 ohms) for the vertical and horizontal front panel BNC connectors is internal to the 067-0711-99, and is accomplished by moving a connector from one position to another.

The output comes through two groups of two peltola connectors located toward the rear of the plug-in. The upper group of connectors is the horizontal output, the lower group of connectors is the vertical output. The upper connector of either group is the 50 ohm output.

#### SELECTING THE PHASE OF THE FRONT PANEL BLANKING OUTPUT

Selection of the phase for the blanking output front panel connector is internal to the 067-0711-99, and is accomplished by moving a connector from one position to another. The blanking output comes through a group of two peltola connectors located toward the front of the circuit board.

Positive phase blanking is defined as where the output goes to a high state for the blanking period. The connector closest to the front of the circuit board is positive phase.

## DETAILED OPERATING INSTRUCTIONS

## CROSSHATCH DISPLAY

An 11-line crosshatch display is used to check and/or adjust crt trace alignment, geometry, and orthogonality. The 110-line crosshatch display is used to check and/or adjust trace focus and astigmatism.

Use the following procedure to obtain a crosshatch display.

1. Set the mainframe intensity and readout controls fully counterclockwise.
2. Within the Calibration Fixture, connect the internal coaxial connectors for 50-ohm impedances.
3. Install the Calibration Fixture in a horizontal compartment of the mainframe. If the mainframe has four plug-in compartments, set the horizontal mode to display the Calibration Fixture.
4. Install an amplifier unit in a vertical compartment. Set the mainframe vertical mode to display this unit.
5. Set the amplifier unit for a deflection factor of 100 millivolts/division with dc input coupling.
6. Connect the VERTICAL OUTPUT connector to the amplifier unit with a BNC coaxial connector.
7. Set the Calibration Fixture controls as follows:

VERT and HORIZ POS	Midrange
Vertical and HORIZ GAIN	Several turns clockwise
AUX Y	OFF
AUX Z	Up (on)
DUTY/LINE	2.0%/11 or 0.2%/11 (as desired)

Allow several minutes warmup.

8. Set the display intensity for normal viewing. The cross-hatch display can be centered with the VERT and HORIZ POS controls. An 11-line display can be set for one line/division with the GAIN controls.
9. If it is desired to use the auxiliary Y-axis (internal vertical) path, delete the amplifier unit from this procedure and set the AUX Y switch Up (on).

#### RASTER DISPLAY

The raster display is used to check and/or adjust mainframe auxiliary Y-axis circuits and crt resolution measurements.

**MAINFRAME Y-AXIS.** The mainframe auxiliary Y-axis gain is checked using the feature of matched AUX-Y and front-panel output levels. The mainframe auxiliary Y-axis circuit requirement is 1 milliamperes/division, which corresponds to a front-panel VERTICAL OUTPUT of 100 millivolts/division (behind the selected output impedance).

To check or calibrate the mainframe auxiliary Y-axis circuit gain, proceed as follows:

1. Set the mainframe intensity and readout controls fully counterclockwise.
2. Within the Calibration Fixture, connect the coaxial connectors for 50-ohm output impedances.
3. Install the Calibration Fixture in a horizontal compartment of the mainframe. If the mainframe has four plug-in compartments,

set the horizontal mode to display the Calibration Fixture.

4. Install an amplifier unit in a vertical compartment. Set the mainframe vertical mode to display this unit.
5. Connect the VERTICAL OUTPUT connector to the amplifier input with a BNC coaxial cable.
6. Set the amplifier unit for dc input coupling. Set the deflection factor at 50 millivolts/division for a 50-ohm input or 100 millivolts/division for a one-megohm input.
7. Set the display intensity for normal viewing.
8. Center the amplifier unit position control.
9. Set the Calibration Fixture controls as follows:
 

VERT and HORIZ POS	Midrange
Vertical and Horizontal GAIN	Several turns clockwise
AUX Y	OFF
AUX Z	Up (on)
MODE	HORIZ RASTER
DUTY/LINE	2.0%/11
10. Set the Calibration Fixture Vertical GAIN control for one line/division.
11. Disconnect and remove the amplifier unit from the mainframe.
12. Set the AUX Y switch to Up (on).
13. Set the VERT POS control to center the display.
14. Check/adjust mainframe display for one line/division in the center six divisions.



RESOLUTION MEASUREMENTS. Resolution measurements are made with a 110-line raster display. Use a horizontal raster for measuring vertical resolution, and vice versa.

Use of the auxiliary Y-axis (internal vertical) circuit is not recommended for vertical resolution measurements or adjustments due to mainframe circuit nonlinearity.

For a go/no-go resolution test, proceed as follows:

1. Install the Calibration Fixture in a mainframe horizontal compartment. If the mainframe has four plug-in compartments, set the horizontal mode to display the Calibration Fixture.
2. Install an amplifier unit in a vertical compartment. Set the mainframe vertical mode to display this unit.
3. Set the amplifier unit deflection factor for 50 millivolts/division for a 50-ohm input or 100 millivolts/division for a one-megohm input.
4. Determine the desired resolution (in lines/division) from the instrument or crt specification.
5. Determine the divisions of display from the formula:

$$\text{Divisions of Display} = \frac{110 \text{ lines}}{\text{lines/division}}$$

For example, a desired vertical resolution of 17 lines/division would require  $\frac{110 \text{ lines}}{17 \text{ lines/division}} =$  approximately 6.5 divisions of display.

6. For a horizontal resolution test, set the Horizontal GAIN for the divisions of display as calculated in step 5. Set the Vertical GAIN for a full-screen display vertically. For a vertical resolution test, set the Vertical GAIN for the calculated display size and the Horizontal GAIN for a full-screen display horizontally.

7. The raster display can be offset with the appropriate position control to check the resolution over the entire crt graticule area.
8. If individual lines in the display can be identified (no overlap), the device passes the resolution test.

To measure the resolution of a given oscilloscope/crt, modify the preceding procedure as follows:

1. Set the appropriate gain control to the fully clockwise position. Set the other gain control for a full-screen display.
2. Slowly reduce the size of the display with the appropriate gain control until the individual lines merge.
3. Measure the size of the display and apply the formula:

$$\text{Resolution (lines/division)} = \frac{110 \text{ lines}}{\text{display size (number of divisions)}}$$

#### TWO DISPLAYS

For comparison purposes, it is desirable to have two simultaneous displays. Two simultaneous displays can be used to compare two mainframes or two beams in a dual-beam mainframe.

Simultaneous displays can be obtained with a minimum number of interconnecting cables through the use of the internal path for one display, while using the front-panel outputs for the other. However, for resolution comparisons where the mainframe circuit nonlinearity is objectionable, the VERTICAL OUTPUT signal can be shared by using a BNC T connector on the VERTICAL OUTPUT connector.

When comparing two mainframes, select the proper phase for the BLANKING (TTL) OUTPUT for the other mainframe.

## CIRCUIT DESCRIPTION: OVERVIEW

The basic display generated by the 067-0711-99 is a crosshatch. Several variations of this basic display are available. The basic crosshatch display can be blanked for a specific time to provide either a horizontal or vertical raster. The display can be composed of 11 or 110 lines (in each direction) with selectable duty factors of .02%, 0.2%, or 2.0% (with 11 lines only).

The crosshatch display is generated by the use of stairstep and sawtooth waveforms that are switched between the vertical and horizontal channels of the oscilloscope.

The following is provided to aid in understanding the overall concept of the 067-0711-99 before individual circuits are discussed in detail.

## CIRCUIT BLOCKS: OVERVIEW

The 067-0711-99 can be divided up into 9 basic functional blocks.

1. The TIMING GENERATOR sets up a sequence of pulses that control the sweep generator, stairstep generator, and the channel switch.
2. The SWEEP GENERATOR develops a sawtooth voltage waveform which is initiated by the timing generator. Reset is internal to the sweep generator, occurring when the sweep waveform exceeds a certain voltage.
3. The STAIRSTEP GENERATOR develops a stairstep voltage waveform, stepping and resetting on command from the timing generator.
4. The UNBLANKING GENERATOR provides a signal to the mainframe AUX (AUXILIARY) Z AXIS path. This signal is derived from both the sweep and timing generators to allow proper blanking (for a pleasing display) and for mode selection of vertical raster, horizontal raster, or crosshatch display.
5. The CONDITIONING AND ISOLATION AMPLIFIERS present a high impedance load to the sweep and stairstep generators, while modifying the dc level and amplitude excursion of the signal to match the dynamic range of the channel switch.
6. The CHANNEL SWITCH is required to generate the crosshatch display from the raster display that would be supplied by the stairstep and sweep generators, and interchanging the X and Y axis at the completion of every frame.  
  
Blanking on one, or the other, or neither phase of the channel switch creates the horizontal raster, vertical raster, or crosshatch display respectively.
7. The OUTPUT AMPLIFIERS that supply the horizontal and vertical signals to the front panel are arranged in a configuration that establishes the center stairstep at the point where the display converges when the gain (also part of this circuit) is reduced. Positioning voltages are also introduced at this point.

8. The INTERFACE AMPLIFIER takes the single-ended signal supplied by the horizontal output amplifier and supplies a differential signal of appropriate amplitude to the main signal path of the mainframe (interface connectors A11 and B11).
9. The AUXILIARY Y-AXIS AMPLIFIER supplies a signal of appropriate amplitude to the AUXILIARY Y-AXIS path in the mainframe from the signal supplied by the vertical output amplifier. Special care is taken to match the gain of this output to the front panel output.

## 1. TIMING GENERATOR

The timing generator derives all of its signals by dividing down from a master oscillator consisting of Q101, Q102, and Q103. Q101 and Q102 are connected as a collector-coupled multivibrator with Q103 as a buffer.

The first division factor is selectable. When a 110-line display is desired, signals must come 10 times as often as for an 11-line display to keep the overall frame repetition rate high enough to avoid display flicker. The signal for the 110-line display is selected by bypassing U101 (which is used as a divide by 10 counter).

U102 is connected as a divide by two counter with both sections used to prevent timing hazards due to device propagation delay. The output drives U103 and U104 in a divide by 10 mode, where the output from these is a negative going pulse with a width equal to the period of the output from U102. (See waveforms on next page.)

The output from U102 and U103 is AND'ed to provide a pulse one-half of the width of the output from U103 and U104. Waveform 3 is used to control the sweep. The rising edge corresponds to the start of the sweep. Waveform 4 is used to control the step generator such that the step is occurring for the duration of the pulse.

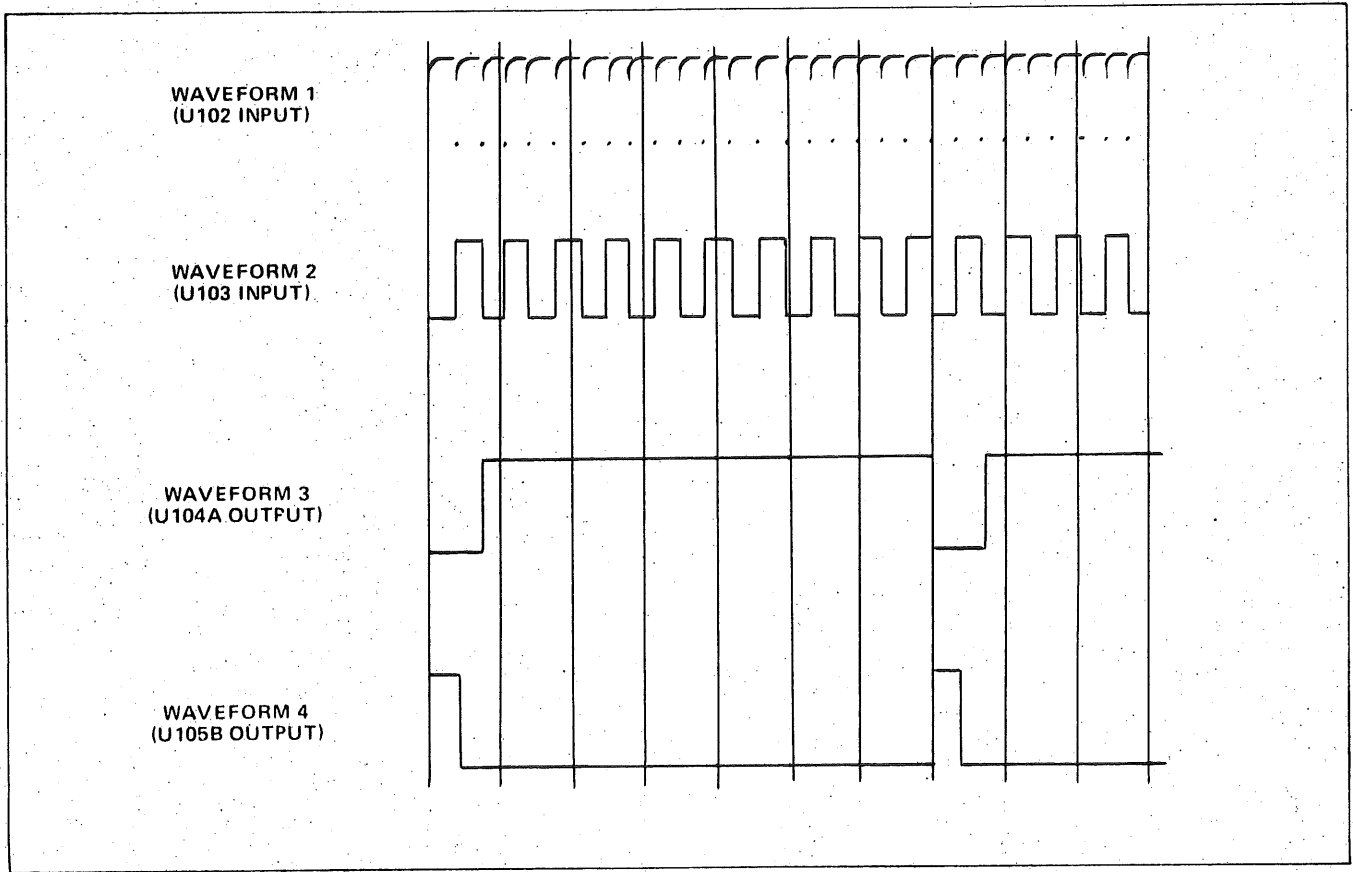

The control sequence is step the staircase generator, wait for the amplifiers to settle, and start the sweep.

As was stated earlier, when selecting a 110-line display, the clock frequency is 10 times faster than that used for generating the 11-line display. The significant effect of this on the output of the timing generator is a ten times decrease in the duration of the command to the step generator, resulting in a step amplitude 10 times smaller than that of a 110-line display step. Another effect is the shorter time for the amplifiers to settle between the end of the step command and the initiation of the sweep in the 110-line position.

The number of lines displayed is determined digitally by counting either 11 or 110 step-command pulses before resetting the stairstep generator and flipping the channel switch. U107 and part of U104 and U108 are used as a divide by 11 counter. U106 is connected as a divide by 10 counter that gives a 110-line display, when used, or an 11-line display when bypassed.

The signal fed to the channel switch is a square wave with complementary outputs that switches with every staircase reset pulse. U110 functions as a divide by 2 counter to accomplish this.



## 2. SWEEP GENERATOR

The sweep generator develops a sawtooth voltage waveform, initiated by the timing generator. Reset is internal to the sweep generator, (backed up by a reset pulse from the timing generator) occurring when the sweep waveform exceeds a certain voltage.

The sawtooth voltage is generated by a current source feeding a capacitor (C122). The current source consists of Q123, R141-R145, and C121, C123, C124. Selection of different duty factors is accomplished by selection of different current magnitudes.

The current is equal to the current through the equivalent resistance (combinations of R141-R143) in the emitter circuit of Q123.

Because the voltage is fixed at this point (at about 8-9 volts as determined by R144 and R145), current is changed by selecting the appropriate resistor configuration.

Reset is accomplished with Q121 and Q122 (both prevented from saturating at higher speeds by CR103 and CR104 respectively) acting as current shunts to both the current source and the charge stored in the capacitor. Two transistors are used in order to provide for the back up reset pulse from the timing generator.

The sawtooth voltage waveform from the capacitor is isolated through the conditioning and isolation amplifiers. The output from the isolation amplifier is used to drive an end-of-sweep comparator consisting of Q124, Q125, R151-R155 and CR105 (connected in a differential amplifier configuration).

The signal from the end-of-sweep comparator resets the sweep multivibrator.

### 3. STAIRSTEP GENERATOR

The stairstep generator provides a stairstep voltage waveform, stepping and resetting on command from the timing generator.

The step generator consists of a gated current source that dumps a charge into capacitor C131 for each step.

The current dumped into the capacitor is developed through Q132, and is determined by the voltage across R165. This voltage is equal to the voltage from the divider consisting of R163 and R164 plus one junction drop.

When Q131 is off, the voltage across R165 is essentially zero, and no current flows. When Q131 is on, the voltage across R165 is about 6 to 7 volts, thus setting up a current of about 0.6 to 0.7 mA to be supplied to the capacitor.

R161 and R162 take the TTL signal from the timing generator and condition it to drive Q131. CR106 is used to prevent Q131 from saturating, thus improving speed.

Reset is accomplished by turning Q133 on hard, draining the charge stored in C131 to ground. A pulse-stretcher circuit consisting of Q134, Q135, R166, R167, R168, and C133, takes the narrow pulse supplied by the timing generator and stretches it in order to ensure that the pulse width is sufficient to discharge capacitor C131.

#### 4. UNBLANKING GENERATOR

The unblanking generator sends a signal to the AUX Z-AXIS path. This signal is derived from both the sweep and timing generators to allow proper blanking for a pleasing display, and mode selection of a vertical raster, horizontal raster, or crosshatch display.

Unblanking is enabled whenever the sweep is running (as sensed by the state of the sweep multivibrator through buffer Q115 when this signal is OR'ed by U109 with the pulse from U104).

This is OR'ed with one, or the other, or neither phase of the timing generator channel switch signal to generate the horizontal raster, vertical raster, or crosshatch display respectively.

Both positive and negative phase blanking signals of TTL levels are available to feed the front-panel BLANKING (TTL) OUTPUT connector.

## 5. CONDITIONING AND ISOLATION AMPLIFIERS

The conditioning and isolation amplifiers present a high impedance to the sweep and staircase generators. This is done with a low input current operational amplifier connected in the voltage follower configuration. (U113 for the sweep and U111 for the staircase).

Signals from these isolation amplifiers are then amplified by the conditioning amplifier connected in a variable-gain amplifier configuration.

An offset voltage is also introduced to this amplifier which, along with the variable gain characteristics, alters the signal to match the dynamic window of the channel switch.

## 6. CHANNEL SWITCH

The channel switch interchanges the staircase and sawtooth waveforms between the horizontal and vertical channels to generate the crosshatch display.

The basic building block of the channel switch consists of 6 diodes and three resistors connected as shown below.

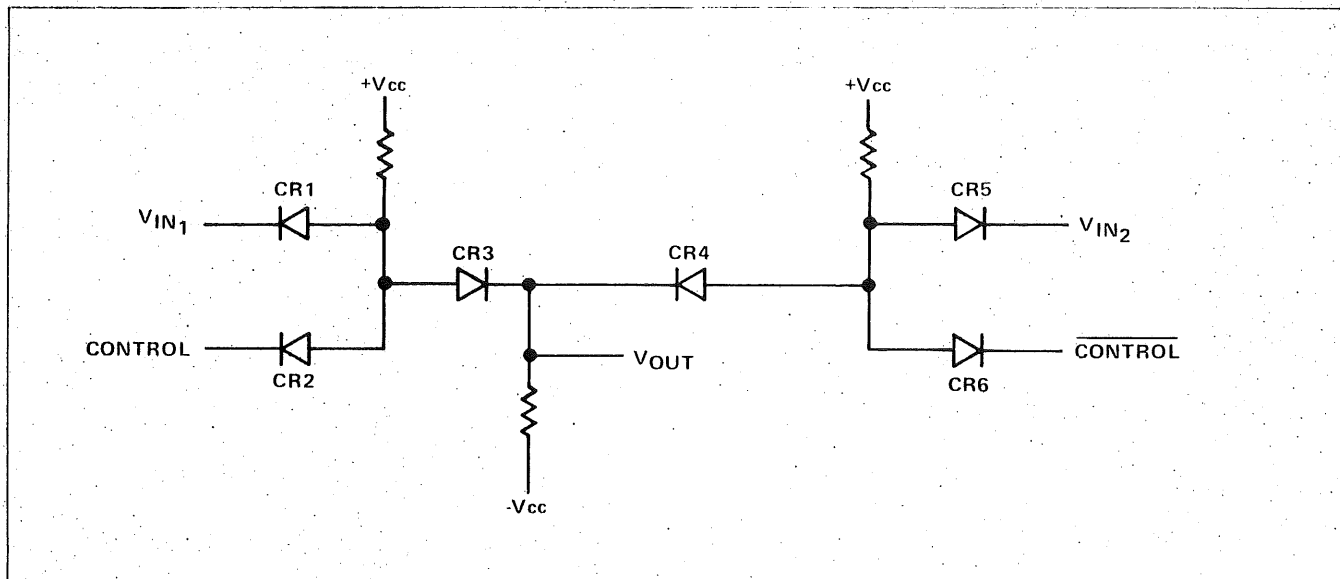

control states (0.4V for low state and 2.4V for high state).

The operation of the left side of the switch is such that when the control voltage is in the high state, CR1 is forward biased and CR2 is reverse biased. The voltage at the anodes of CR1, CR2, and CR3 is then equal to  $V_{IN1}$  plus one junction drop.

On the right side of the switch the control voltage ( $\overline{\text{CONTROL}}$ ) is at the low state. So, the voltage at the anodes of CR4, CR5, and CR6 is equal to the control voltage ( $\overline{\text{CONTROL}}$ ) plus one junction drop. Because of the window defined for the input signal, this voltage is also lower than at the point common to CR1, CR2, and CR3. In this state, CR3 is forward biased and CR4 reverse biased so the output is brought down a junction drop from the voltage at the anodes of CR1, CR2, and CR3.

This makes the output voltage equal to the input voltage, and tends to compensate for the diodes temperature coefficient.

Reversing the state of the control voltages switches which  $V_{in}$  is present at  $V_{out}$ .

## 7. OUTPUT AMPLIFIERS

The output amplifiers take the signal from the channel switch (which has previously been shifted in level and amplitude to fit into the range of the channel switch) and recenters it. This is done by adjusting the dc offset of the conditioning and isolation amplifiers such that (for the vertical channel) the voltage drop across R193 (due to the current supplied by long tail resistor R194) brings the center staircase to 0 volts at TP1 so the display will collapse around the center staircase when the gain is reduced. The horizontal channel is adjusted with R198 to match the dc level of the vertical channel.

The gain is controlled with a 10K-ohm potentiometer connected as a variable voltage divider (R301 vertical, R201 horizontal).

The signal from the gain pots is applied to an inverting amplifier with a voltage gain of three (consisting of R202, R203, and U115 in the case of the horizontal channel and R302, R303 and U116 in the vertical channel).

The positioning voltage is also applied at this stage. The voltage is determined by R204, R205, R206, and R207 for the horizontal and R304, R305, R306, and R307 for the vertical.

The front panel output of the plug-in is isolated from the output of the amplifier through either a 49.9 or 200 ohm resistor (to select the output impedance).

Resistor R209 is used to offset the dc current requirements of the interface amplifier allowing the output at U115 to swing more volts before device current limiting occurs.

## 8. THE INTERFACE AMPLIFIER

The interface amplifier takes the signal from the horizontal output amplifier and conditions it so it meets the requirements of the mainframe. The nominal signal level from the horizontal output amplifier is 100mV/division centered around 0 volts. The signal required by the mainframe is a differential voltage of 50mV/division into 50 ohms.

The circuitry consisting of R209, R211, R221-R228, Q141, Q142, VR131, R132 and U117 accomplish this change through the use of a differential amplifier involving Q141 and Q142. The center screen deflection voltage is 0 volts, so in order to keep several volts across the transistors, the center voltage from the output amplifier (also 0 volts) is shifted up 5.1 volts by the use of zener diode VR131.

The asymmetrical amplifier configuration requires the base of Q142 to be at a higher voltage than that of Q141 for a balanced current condition. U117, R227, R228, and VR132 determine this voltage. A current of 8.3 mA is supplied by R227 which sets up a voltage across R228 (dependent upon the setting of R228). Zener diode VR132 (which is of the same type as VR131) is used for another 5.1 volt drop. Use of this second zener diode for most of the voltage difference required tends to compensate for any temperature coefficient that may be encountered.

R223 is used to achieve thermal balance. Pulldown current for the amplifier is supplied by R221 and R224 (7.5 mA at center screen). Overvoltage protection for the mainframe is provided by CR133 and CR134.

## 9. AUXILIARY Y-AXIS AMPLIFIER

The auxiliary y-axis amplifier takes the signal from the vertical output amplifier and conditions it so it meets the requirements of the mainframe. The nominal signal level from the vertical output amplifier is 100 mV/division (centered about 0 V). The signal required by the mainframe is current of 1 mA/division (centered about 0 mA) with a source impedance of greater than 1 thousand ohms.

The circuitry consisting of Q143, Q144, and R321-R328 is a feedback voltage amplifier (to the emitter of Q144) with a voltage gain of 0.996 when R321 is properly adjusted. The voltage swing of 100 mV/division is then 99.6 mV at this point, and when applied across the parallel equivalent of R392, R326 and R327 (99.6 ohms) this becomes 1 mA/division output swing through Q144. Pulldown current for the amplifier is supplied by R325 (7.5 mA at center screen). Overvoltage protection for the mainframe is provided by CR141 and CR142.

The gain of the auxiliary y-axis circuit was set up to match that of the front panel output. (That is, 1 division deflection out the front panel at 100 mV/division equals one division deflection through the auxiliary Y-Axis path).

The tolerances are set up such that regardless of where R321 (aux y gain) is set, the gain would match within the 10% mainframe tolerance. This is useful only for mainframes that have an adjustable AUX Y gain.

To check mainframe aux y deflection factors where the mainframe gain can't be adjusted, provisions are made to match the plug-in aux y gain to the front panel output through the use of R321 (as outlined in the calibration procedure).



CALIBRATION:

## TEST EQUIPMENT REQUIRED

1. Amplifier plug-in unit for use with Tektronix 7000-series oscilloscopes. Bandwidth, 1 MHz or greater; deflection factor, 1 volt to 5 millivolts/division; 1 megohm input resistance. Tektronix 7A16 used in these checks.
2. Oscilloscope. Any 7000-series oscilloscope.
3. Plug-in extender. Tektronix part 067-0589-00.
4. 1X probe. Tektronix P6011 used for these checks.
5. BNC-to-probe tip adapter. Tektronix part 012-0092-00.
6. Screwdriver. Three-inch shaft, 3/32 inch bit.
7. Clip leads (two).

## PROCEDURE

The following procedure is arranged so the 067-0711-99 can be calibrated with the least interaction of adjustments and reconnection of equipment. The control settings continue from the preceding step(s) unless otherwise noted. The instrument should be calibrated at an ambient temperature of  $25^{\circ} \pm 5^{\circ} \text{C}$ .

## PRELIMINARY CONTROL SETTINGS

067-0711-99 (HORIZONTAL COMPARTMENT VIA PLUG-IN EXTENDER)

ALL INTERNAL CONTROLS MUST BE CENTERED FOR CALIBRATION.

MODE	VERTICAL RASTER
VERTICAL POSITION (COARSE & FINE)	Midrange
HORIZONTAL POSITION (COARSE & FINE)	Midrange
VERTICAL GAIN	5 turns CW.*
HORIZONTAL GAIN	5 turns CCW.*
AUX Y	OFF
AUX Z	On.
DUTY/LINE	2.0%/11

TEST AMPLIFIER (LEFT VERTICAL PLUG-IN COMPARTMENT.)

Position	Midrange
Polarity	+UP
Bandwidth	20 MHz
Volts/Div	200 mV
Coupling	D.C.

\*Note: Mechanical rotation of the gain control is not limited to the 4.5 turn limit of the pot.

## TEST OSCILLOSCOPE

Intensity	AT A USABLE LEVEL
Vertical Mode	LEFT
Readout	OFF

## 1. INTERNAL SETUP OF 067-0711-99

Connect clip lead between test points 3 and 4.

2. Turn oscilloscope power on. Allow several minutes warm up before proceeding with calibration. Advance the Intensity control until a spot is observed.

## 3. ADJUST STAIRCASE DC BALANCE AND GAIN

- a. Connect 7A16 to test point 1 through 1X probe.
- b. Set the input selector of the test amplifier to ground and center the spot vertically with the position control on the test amplifier. Set the amplifier for dc input coupling.
- c. Adjust R171 so there are 5 divisions between the first and the eleventh (last) dot. Use R184 for position control do not use position control on test amplifier.
- d. Adjust R184 so that the center dot of the 11 dot display is at the vertical center of the screen.

## 4. ADJUST SAWTOOTH D.C. BALANCE AND GAIN

- a. Set mode switch to CROSSHATCH. (Vertical line should appear superimposed on the dots.)
- b. Set the DUTY/LINE switch to 2.0% at 11 LINES.
- c. Adjust R175 until the line is 7 divisions long. Use R183 for position control - do not use position control on test amplifier.
- d. Adjust R183 until the line is centered around the dots.

## 5. ADJUST CHANNEL SWITCH BALANCE

- a. Set MODE switch to HORIZ RASTER.  
Set DUTY/LINE switch to 2.0% at 11 LINES
- b. Connect probe to test point 2.

- c. Adjust R198 so that the center dot of the display lines up with the center line of the graticule vertically.
6. ADJUST HORIZONTAL AMPLIFIER D.C. BALANCE & COMMON MODE
    - a. Set test amplifier to 5 mV/div. Using BNC to probe tip adapter, connect probe to front panel horizontal output.
    - b. Remove cliplead from 067-0711-99 (test point 3 & 4).
    - c. Set test oscilloscope BEAMFINDER to lock.
    - d. Adjust front panel coarse and fine horizontal position controls until the dot is centered vertically.
    - e. Connect probe to test point 3. Adjust R228 to position the dot at the center of the screen vertically.
    - f. Connect probe to test point 4. Adjust R226 to position the dot at the center of the screen vertically.
    - g. Unlock test oscilloscope BEAMFINDER and repeat steps e and f.
  7. CHECK HORIZONTAL FRONT PANEL OUTPUT NOISE (<1 mV/Line tangentially measured)
    - a. Using BNC to probe-tip-adapter, connect probe to front-panel horizontal output.
    - b. Set horizontal GAIN 5 turns CCW.
    - c. Using HORIX POS, set the dot to center screen vertically.
    - d. Set horizontal GAIN for a dot/2 div display vertically (10 mV/line).
    - e. Set DUTY/LINE to .2% at 110 LINES.
    - f. Check that each dot can be distinguished.
  8. CHECK HORIZONTAL INTERFACE OUTPUT NOISE (<1 mV/Line/side tangentially measured)
    - a. Connect probe to test point 3.
    - b. Set DUTY/LINE to 2% at 11 LINES.
    - c. Set horizontal GAIN for a dot/2 div display vertically (10 mV/line).
    - d. Set DUTY LINE to .2% at 110 LINES.
    - e. Check that each dot can be distinguished.

- f. Move probe to Test Point 4.
  - g. Check that each vertical dot can be distinguished.
9. CHECK VERTICAL FRONT PANEL OUTPUT NOISE  
( $<1$  mV/Line tangentially measured)
- a. Connect probe to front panel VERTICAL OUTPUT through BNC to probe tip adapter.
  - b. Set vertical GAIN 5 turns CCW.
  - c. Set MODE switch to VERT RASTER.
  - d. Set DUTY/LINE to 2% at 11 LINES.
  - e. Set VERT POS so that the horizontal div line is centered vertically.
  - f. Adjust vertical GAIN for a dot/2 div display vertically (10 mV/line).
  - g. Check that each horizontal line can be distinguished.
10. ADJUST AUX Y PATH GAIN
- a. Set HORIZ GAIN at least 5 turns CW.
  - b. Move AUX Y harmonica from operate position (P603) to the test position (P803).
  - c. Connect test amplifier probe to front panel VERTICAL OUTPUT through BNC to probe tip adapter.
  - d. Set test amplifier VOLTS/DIV to 50 mV/div.
  - e. Adjust the VERTICAL GAIN control of the 067-0711-99 for a line/2 div display vertically.
  - f. Switch AUX Y on.
  - g. Connect probe to test point 5.
  - h. Adjust R321 until the display is 1 line/div.
  - i. Move AUX Y harmonica from test position to the operate position.
- Complete calibration by removing the probe and BNC-to-probe tip adapter and putting side covers on the 067-0711-99.

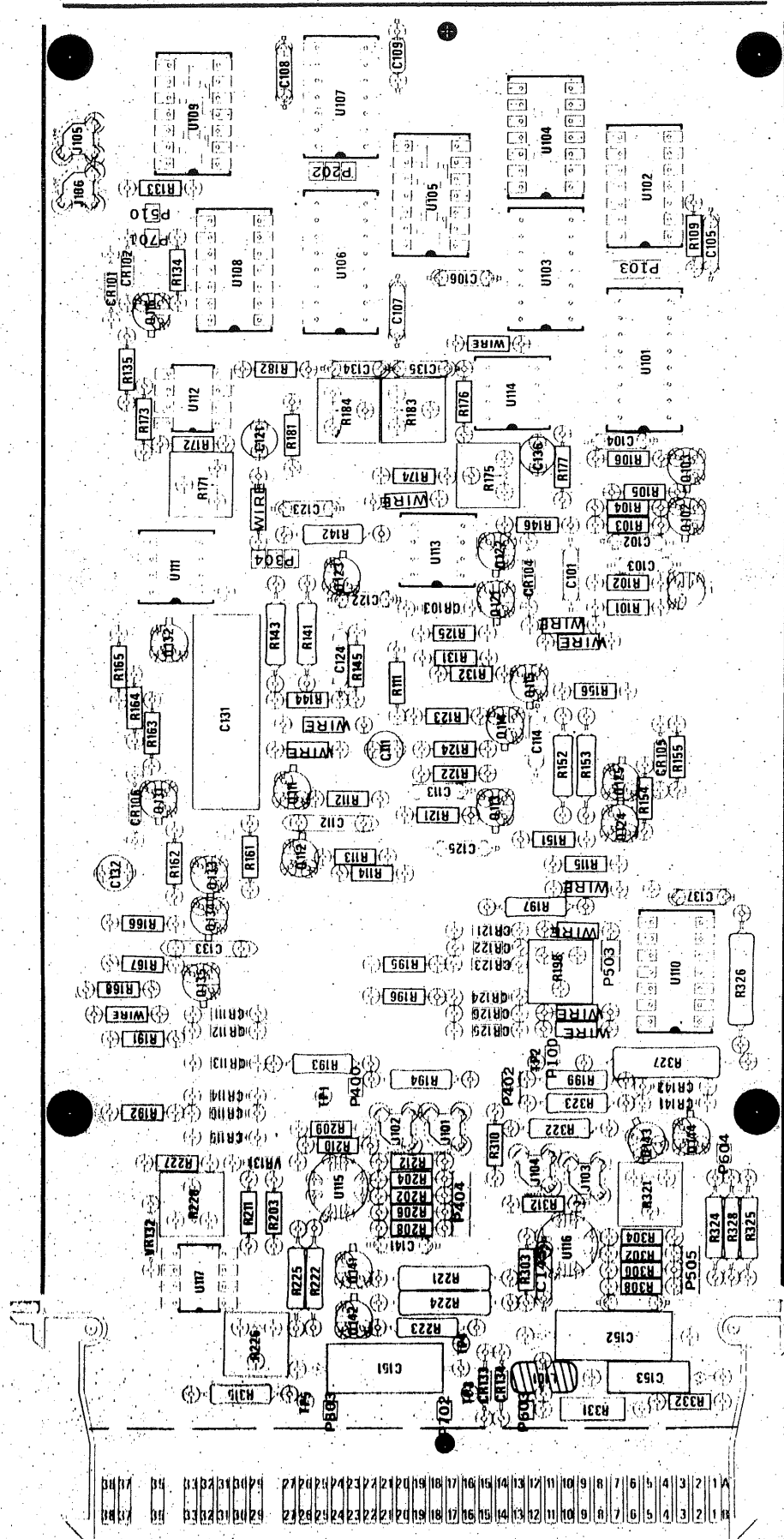

CIRCUIT BOARD COMPONENT LAYOUT

W1	W2	W3	W4	W5	W6	W7	W8	W9	W10	W11	W12	W13	W14	W15	W16	W17	W18	W19	W20	W21	W22	W23	W24	W25	W26	W27	W28	W29	W30	W31	W32	W33	W34	W35	W36	W37	W38	W39	W40	W41	W42	W43	W44	W45	W46	W47	W48	W49	W50	W51	W52	W53	W54	W55	W56	W57	W58	W59	W60	W61	W62	W63	W64	W65	W66	W67	W68	W69	W70	W71	W72	W73	W74	W75	W76	W77	W78	W79	W80	W81	W82	W83	W84	W85	W86	W87	W88	W89	W90	W91	W92	W93	W94	W95	W96	W97	W98	W99	W100
----	----	----	----	----	----	----	----	----	-----	-----	-----	-----	-----	-----	-----	-----	-----	-----	-----	-----	-----	-----	-----	-----	-----	-----	-----	-----	-----	-----	-----	-----	-----	-----	-----	-----	-----	-----	-----	-----	-----	-----	-----	-----	-----	-----	-----	-----	-----	-----	-----	-----	-----	-----	-----	-----	-----	-----	-----	-----	-----	-----	-----	-----	-----	-----	-----	-----	-----	-----	-----	-----	-----	-----	-----	-----	-----	-----	-----	-----	-----	-----	-----	-----	-----	-----	-----	-----	-----	-----	-----	-----	-----	-----	-----	-----	-----	-----	------



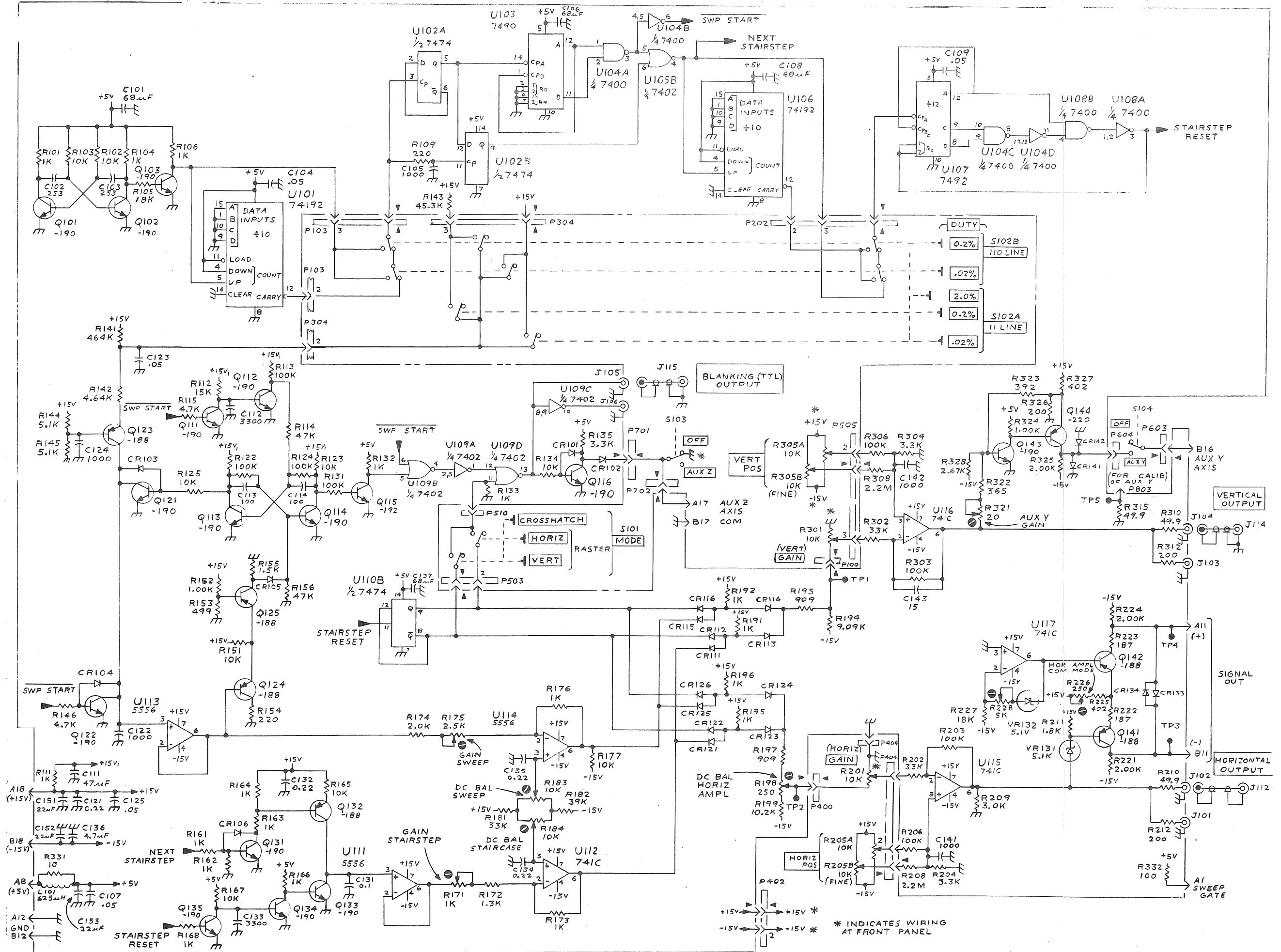

067-0711 CALIBRATION FIXTURE

CROSSHATCH/RASTER GENERATOR