



CRT DATA

T4540

4-19-68

CRT Engineering

DESCRIPTION

The T4540 is an aluminized, 3-3/8 x 3-7/8-inch, rectangular flat-faced cathode-ray tube designed for oscilloscope use. The T4540 has electrostatic focus and deflection, a mesh shielded helical post accelerator, a low power cathode, a distributed vertical deflection structure, and a lighted internal graticule.

ELECTRICAL DATA

Focusing method	Electrostatic
Deflecting method	Electrostatic
Heater voltage	6.3 ±0.3 volts RMS
Heater current at 6.3 volts	103 ±5 mA
Direct interelectrode capacitance, approximate:	
Cathode to all other electrodes	3.3 pF
Grid no. 1 to all other electrodes	9.6 pF
D1 to D2	1.9 pF
D1 to all other electrodes	7.0 pF
D2 to all other electrodes	6.7 pF
Post-accelerator helix resistance	200 MΩ min 4000 MΩ max
Deflection plates:	
D3, D4 nominal characteristic impedance	700 ohms balanced

MECHANICAL DATA

Overall length	15-3/4 ±1/8 inches
Greatest bulb dimensions ¹	
Width	3.840 ±0.060 inches
Height	3.340 ±0.060 inches
Minimum useful screen dimensions	
Width	3-3/16 inches
Height	2 inches
Bulb number	Special
Bulb contact	J1-21
Base ²	Special
Basing	Special
Bulb contact alignment:	
J1-21 contact aligns 45° clockwise from D3-D4 trace	±5°
J1-21 contact on same side as pin no. 4	
Base alignment:	
Pin no. 14 aligns with D3-D4 trace	±5°
Positive voltage on D1 deflects beam approximately toward pin no. 3	
Positive voltage on D3 deflects beam approximately toward pin no. 14	
Angle between D1-D2 and D3-D4 trace	±90° ±1°
Gun to graticule alignment	±3°

RATINGS (design maximum values)³

Post-accelerator voltage	18000 volts DC max
Post-accelerator grid voltage	2500 volts DC max
Lower helix and isolation shield voltage	2500 volts DC max
D1-D2 shield voltage	2500 volts DC max
D3-D4 shield voltage	2500 volts DC max
Average deflection plate voltage	2500 volts DC max
Ratio of post-accelerator voltage to average voltage of deflection plates ⁴	7 max
Astigmatism electrode voltage	2500 volts DC max
Focusing electrode voltage	800 volts DC max
Accelerator voltage	2500 volts DC max
Accelerator input	6 watts max
Grid no. 1 voltage:	
Negative-bias value	200 volts DC max
Positive-bias value	0 volts DC max
Positive-peak value	2 volts DC max
Peak heater-cathode voltage:	
Heater negative to cathode:	
During warm-up period not to exceed 15 seconds	180 volts DC max
After equipment warm-up period	125 volts DC max
Heater positive to cathode	125 volts DC max
Peak voltage between astigmatism and/or any deflection electrode	500 volts DC max

TYPICAL OPERATING CONDITIONS³

Post-accelerator voltage	14000 volts DC
Post-accelerator grid voltage	1960 volts DC
Lower helix and isolation shield voltage	2000 volts DC
D1-D2 shield voltage ⁵	1975 to 2050 volts DC
D3-D4 shield voltage	2000 volts DC
Average D1-D2 deflection plate voltage	2025 volts DC
Average D3-D4 deflection plate voltage	2000 volts DC
Astigmatism electrode voltage ⁶	1960 to 2035 volts DC
Focusing electrode voltage ⁶	180 to 450 volts DC
Accelerator voltage	2000 volts DC
Grid no. 1 voltage ⁷	-75 to -105 volts DC
Deflection factors:	
D1 and D2 ⁸	11.0 to 12.6 volts DC/div
D3 and D4 ⁸	4.3 to 4.9 volts DC/div
Useful scan D1-D2 ⁹	10 div
Useful scan D3-D4 ⁹	6 div
Focusing electrode current for any operating condition	-10 μ A to +10 μ A
Spot position (undeflected) ¹⁰	within ± 0.5 major div from geometric center
Pattern distortion at 100% useful scan ¹¹	1.5%

MAXIMUM CIRCUIT VALUES

Grid no. 1 circuit resistance	1.5 M Ω max
-------------------------------------	--------------------

NOTES

1. Not including graticule lighting hardware. See outline drawing.
2. See outline drawing. The socket for this tube should not be rigidly mounted. It should have flexible leads and be allowed to move freely so that it cannot impress lateral strains through the socket contacts onto the base pins.
3. All voltages taken with respect to cathode.
4. This tube is designed for optimum performance when operating at a ratio of 7. Operation at other ratios may result in changes in deflection uniformity, pattern distortion, and/or useful scan.
5. Pattern distortion is minimized by proper adjustment of this potential.
6. Recommended range. Adjust for best overall focus.
7. Visual extinction of undeflected spot.
8. Major graticule divisions are 8 mm.
9. The deflection plates intercept part of the electron beam near the edge of scan; therefore, a low-impedance deflection drive is desirable.
10. Connect free deflection electrodes to accelerator.
11. With a 6 x 10 div rectangular raster centered on the face of the tube, the raster edges will not deviate from straight parallel lines by more than 0.5 minor div total on the left and right edges, nor by more than 0.5 minor div total at the top and bottom.

15.750 ± .125

10.375 ± .125

9.125 ± .125

.0385 ± .001 (TYP)

2.000 ± .030

J1-21

D3 IN

D3 OUT

D4 IN

D4 OUT

432-0053-00

1.875 ± .060

12.250 ± .125

3.125 ± .125

.750

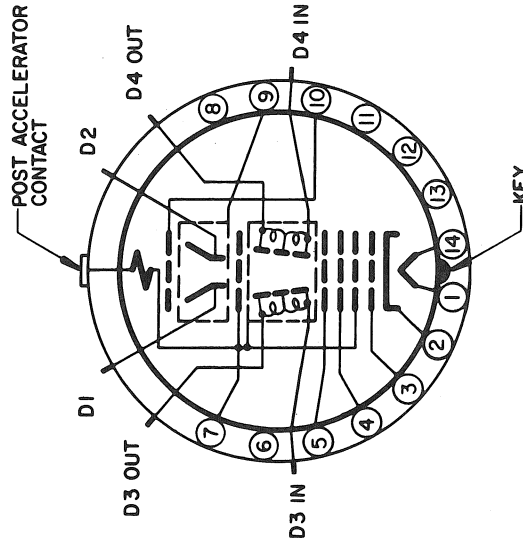
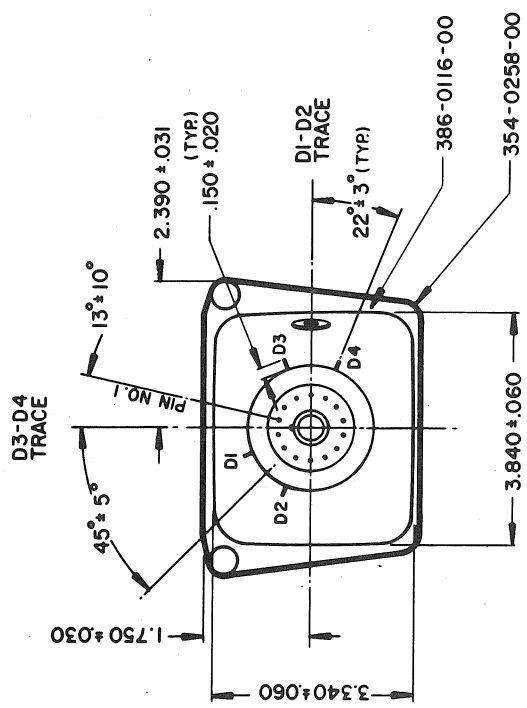

BASE CONNECTIONS

- | | |
|---------|--------------------------------------|
| 1,14 | HEATER |
| 2 | CATHODE |
| 3 | GRID NO.1 |
| 4 | FOCUSING ELECTRODE |
| 5 | ASTIGMATISM ELECTRODE |
| 6,11,13 | I.C. (GRID NO.1 INTERNAL CONNECTION) |
| 7 | ACCELERATOR & LOWER HELIX |
| 8,12 | N.C. |
| 9 | D1-D2 SHIELD |
| 10 | POST ACCELERATOR GRID |



DISPLAY DEVICES DEVELOPMENT
TEKTRONIX, INC.
 BEAVERTON ORE., U. S. A. 97005

TUBE TYPE: **T4540--1**
 DATE: _____
 MOD. _____