

Instructions

067-1007-00
CALIBRATION FIXTURE
(KERNEL TEST BOARD)

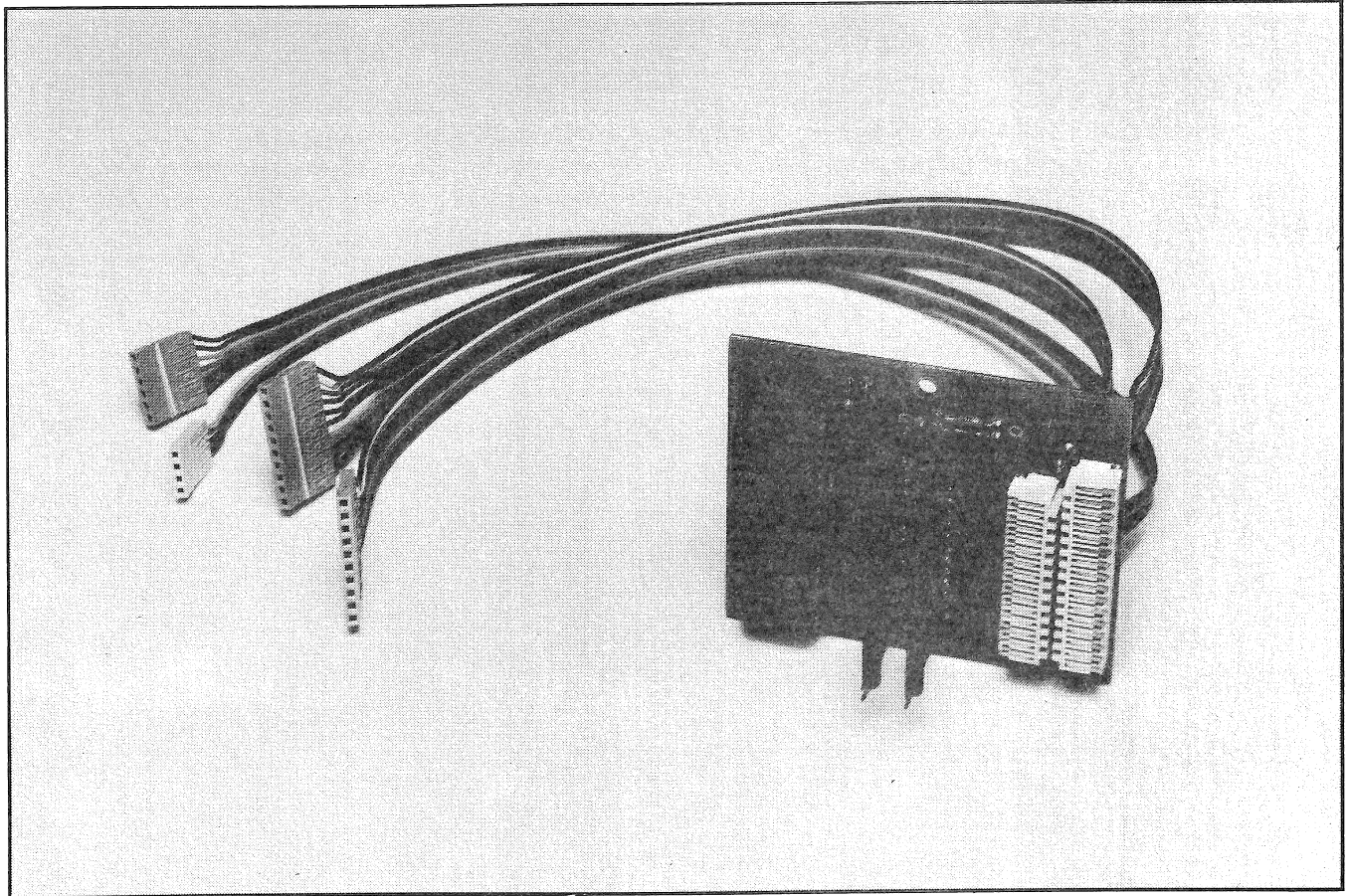

3706-1

The 067-1007-00 Kernel Test Board is a TEKTRONIX test aid designed for use in troubleshooting certain TM 500/TM 5000 microprocessor-based counters or other instruments. It is used with a signature analyzer to verify signatures in the kernel circuitry (microprocessor, some ROM and RAM, and associated circuit paths).

The Kernel Test Board contains a 6502 microprocessor, two sets of pullup resistors, and four connectors. Four cables are included. The 6502 microprocessor replaces the function of the original microprocessor in the instrument under test (original microprocessor is removed). The Data lines for the Kernel Test Board microprocessor are hardwired to produce a NOP (no operation) instruction code. The Address lines are connected to the instrument's Address lines. The instrument's Data lines are pulled high by the pullup resistors.

The Kernel Test Board connects through J1002 and J1003 and/or J1000 and J1001 to the instrument under test. Specific connection information and signatures are provided in the instruction manual for the instrument under test. TP1000 provides the START/STOP signal for the signature analyzer; GND and CLOCK connections for the analyzer are made to the instrument under test as indicated in its instruction manual. With proper connection to the signature analyzer and the instrument, the Kernel Test Board's microprocessor sequentially addresses each location in the instrument's address space; then this sequence repeats until the instrument is turned off.

The LED, DS1001, illuminates when +5 V from the instrument under test is applied to the Kernel Test Board.

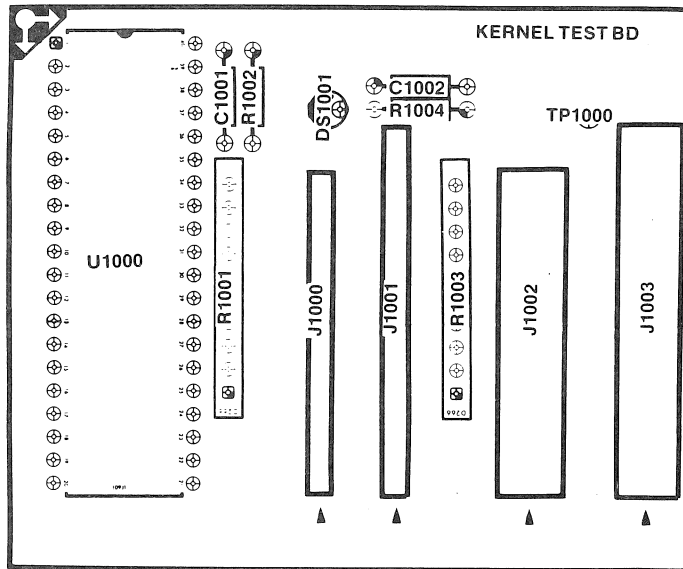

3706-2

A | B | C | D | E | F | H | J | K | L | M

1
2
3
4
5
6
7
8

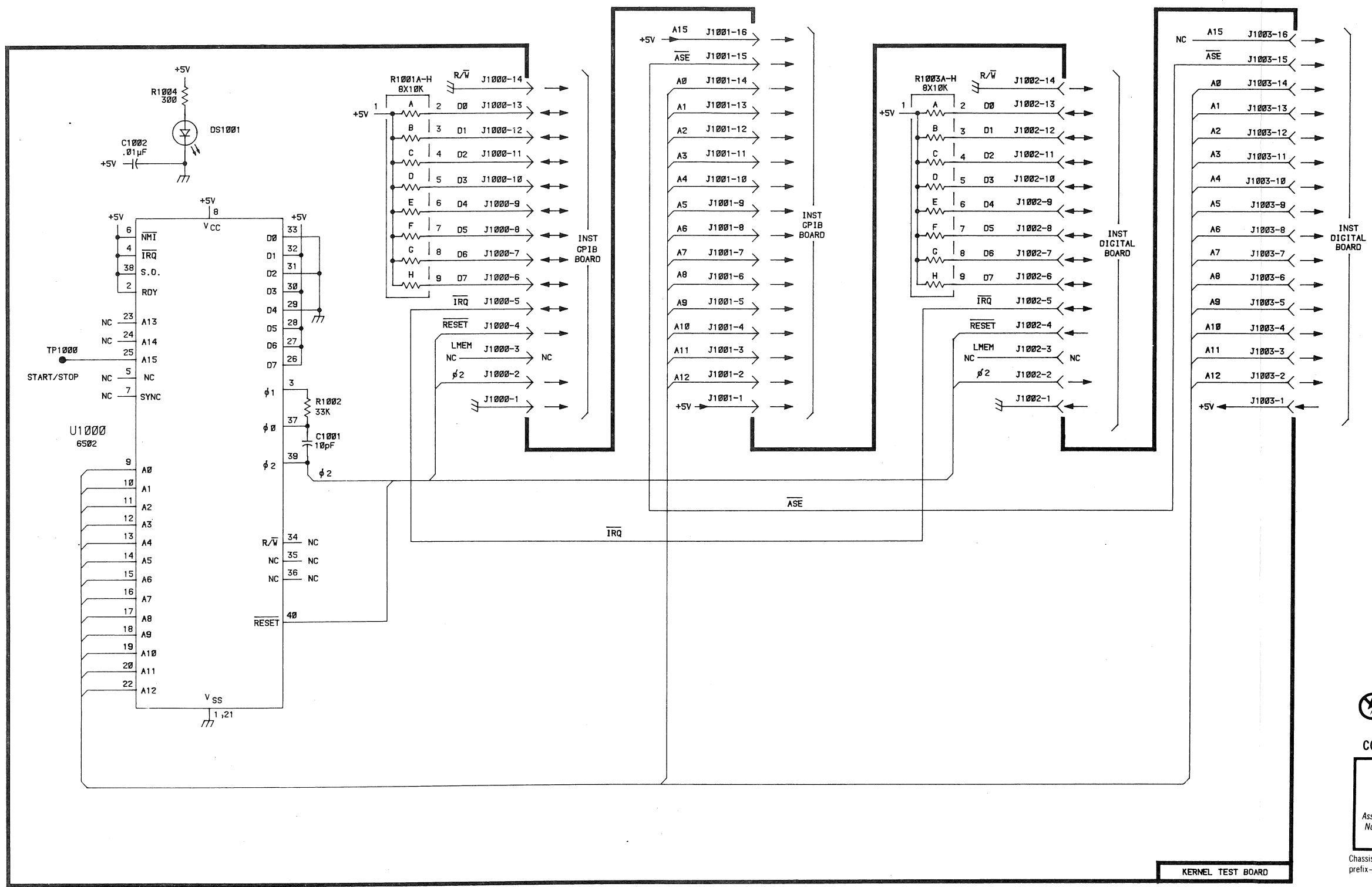

067-1007-00

3706-01

KERNEL TEST BOARD

JS

Static Sensitive Devices
See Maintenance Section

COMPONENT NUMBER EXAMPLE

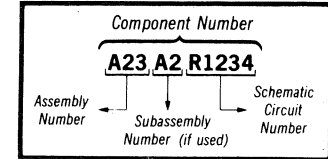

Chassis-mounted components have no Assembly Number prefix—see end of Replaceable Electrical Parts List.

Replaceable Parts—067-1007-00

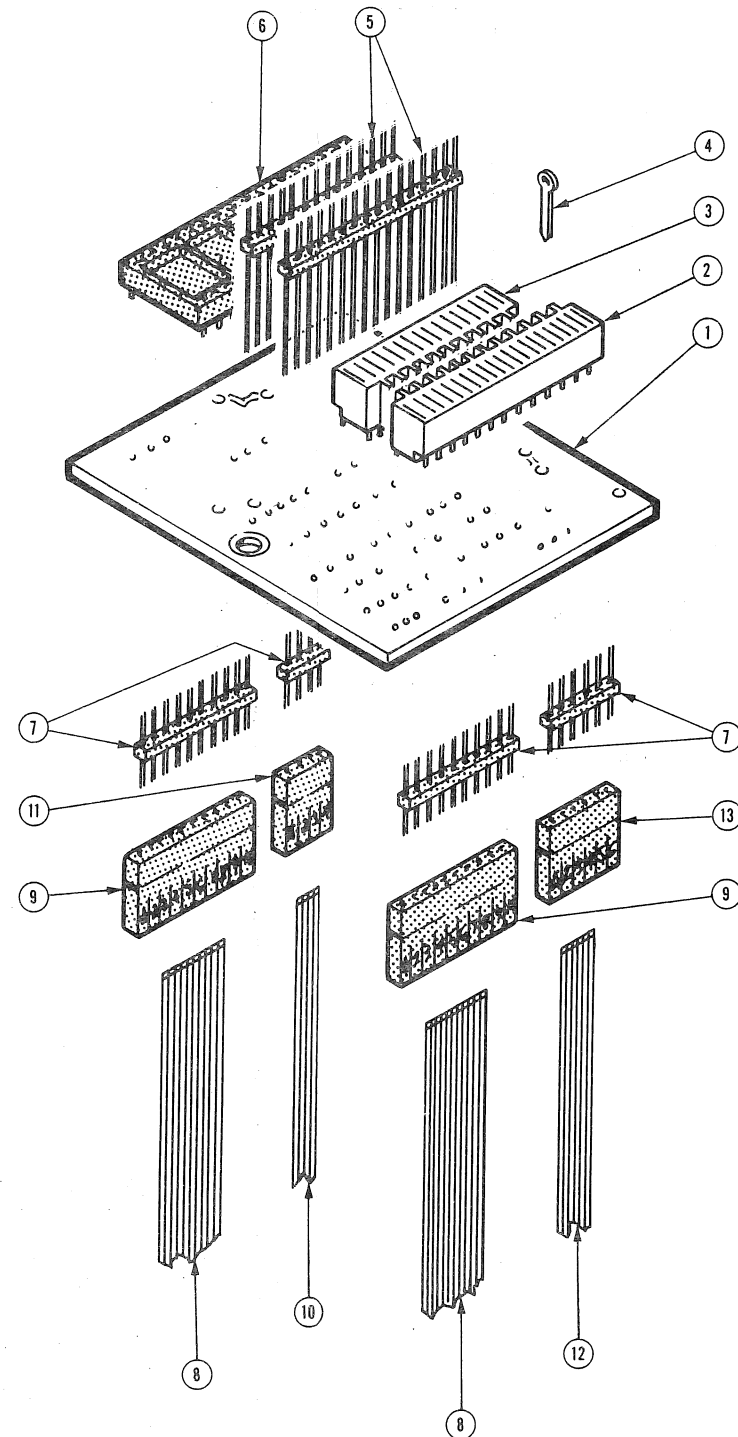

Replaceable Electrical Parts

Ckt No.	Tektronix Part No.	Serial/Model No. Eff	Dscont	Name & Description	Mfr Code	Mfr Part Number
	670-7056-00			CKT BOARD ASSY:KERNEL TEST	80009	670-7056-00
C1001	281-0811-00			CAP.,FXD,CER DI:10PF,10%,100V	72982	8035D2AADG1G100K
C1002	281-0773-00			CAP.,FXD,CER DI:0.01UF,10%,100V	72982	8005H9AADW5R103K
DS1001	150-1036-00			LAMP,LED:RED,3.0V,40MA	01295	TIL 209A
R1001	307-0446-00			RES,NTWK,FXD FI:10K OHM,20%,(9) RES	91637	MSP10A01-103M
R1002	315-0333-00			RES.,FXD,CMPNS:33K OHM,5%,0.25W	01121	CB3335
R1003	315-0511-00			RES.,FXD,CMPNS:510 OHM,5%,0.25W	01121	CB5115
R1004	315-0301-00			RES.,FXD,CMPNS:300 OHM,5%,0.25W	01121	CB3015
TP1000	214-0579-00			TERM,TEST POINT:BRS CD PL	80009	214-0579-00
U1000	156-1425-00			MICROCIRCUIT,DI:MICROPROCESSOR,8 BIT	34576	R6502(P OR C)

Replaceable Mechanical Parts

Fig. & Index No.	Tektronix Part No.	Serial/Model No. Eff	Dscont	Qty	1	2	3	4	5	Name & Description	Mfr Code	Mfr Part Number
	067-1007-00			1						FIXTURE,CAL:SERVICE KIT	80009	067-1007-00
-1				1						CKT BOARD ASSY:KERNEL TEST(SEE REPL)		
-2	136-0499-16			1						CONNECTOR,RCPT,:16 CONTACT	00779	4-380949-6
-3	136-0499-14			1						CONNECTOR,RCPT,:14 CONTACT	00779	4-380949-4
-4				1						TEST POINT:(SEE TP1000 REPL)		
-5	131-2132-01			1						CONN,RCPT,ELEC:HEADER,1 X 36,0.1 CTR	22526	65506-436
-6	136-0623-00			1						SOCKET,PLUG-IN:40 DIP,LOW PROFILE	73803	CS9002-40
-7	131-1343-00			1						TERM. SET,PIN:36-0.525 L X 0.025 SQ	22526	65501-136
-8	175-3542-00			2						CA ASSY,SP,ELEC:10,26 AWG,12.0 L,RIBBON	80009	175-3542-00
-9	352-0168-03			4						CONN BODY,PL,EL:10 WIRE ORANGE	80009	352-0168-03
-10	175-3540-00			1						CA ASSY,SP,ELEC:4,26 AWG,12.0 L,RIBBON	80009	175-3540-00
-11	352-0162-04			2						CONN BODY,PL,EL:4 WIRE YELLOW	80009	352-0162-04
-12	175-3648-00			1						CA ASSY,SP,ELEC:6,26 AWG,12.0 L,RIBBON	80009	175-3648-00
-13	352-0164-02			2						CONN BODY,PL,EL:6 WIRE RED	80009	352-0164-02

CROSS INDEX—MFR. CODE NUMBER TO MANUFACTURER

Mfr. Code	Manufacturer	Address	City, State, Zip
00779	AMP, INC.	P O BOX 3608	HARRISBURG, PA 17105
01121	ALLEN-BRADLEY COMPANY	1201 2ND STREET SOUTH	MILWAUKEE, WI 53204
01295	TEXAS INSTRUMENTS, INC., SEMICONDUCTOR GROUP	P O BOX 5012, 13500 N CENTRAL EXPRESSWAY	DALLAS, TX 75222
22526	BERG ELECTRONICS, INC.	YOUK EXPRESSWAY	NEW CUMBERLAND, PA 17070
34576	ROCKWELL INTERNATIONAL CORP.		
72982	ELECTRONIC DEVICES DIVISION	3310 MIRALBMA AVE.	ANAHEIM, CA 92803
73803	ERIE TECHNOLOGICAL PRODUCTS, INC.	644 W. 12TH ST.	ERIE, PA 16512
80009	TEXAS INSTRUMENTS, INC., METALLURGICAL MATERIALS DIV.	34 FOREST STREET	ATTLEBORO, MA 02703
91637	TEKTRONIX, INC.	P O BOX 500	BEAVERTON, OR 97077
	DALE ELECTRONICS, INC.	P. O. BOX 609	COLUMBUS, NE 68601