

# INSTRUCTION MANUAL

## **BCD**

### **LIMIT CONVERTERS**

Copyright © 1964 by Tektronix, Inc.,  
Beaverton, Oregon. Printed in the United  
States of America. All rights reserved.  
Contents of this publication may not be re-  
produced in any form without permission  
of the copyright owner.

*Tektronix, Inc.*

S.W. Millikan Way ● P. O. Box 500 ● Beaverton, Oregon ● Phone MI 4-0161 ● Cables: Tektronix

# BCD LIMIT CONVERTERS

## CHARACTERISTICS

### General Information

The Tektronix Type 262 Programmer test limits are easily changed when using the Binary Coded Decimal (BCD) Limit Converters. Each converter, Upper and Lower, selects the preset limits of any digital program card by externally applied 1-2-2'-4 or 1-2-4-2' BCD coded ground connections. The converters plug into any Type 262 auxiliary program card connectors.

Use of the converters requires addition of a few connections inside the Type 262. Each lead can be number 22 insulated, unshielded wire, soldered in place as described in the operating instructions.

### External Connections

The BCD data input lines are available at the rear-panel connector J301 for Type 262 program limit selection by an external device. The external circuit selects a digital program card limits by grounding the correct data lines. Each data line rests at about +25 volts, and must be either grounded or taken within +1.5 volts of ground in order to operate the converter. If the external circuit rises above +22 volts, a disconnect diode must be inserted in the data line to automatically disconnect the converter input. Current to ground is about 0.43 ma for each data line.

### Selectable No-Go Limits

Type 262 digital program cards Upper No-Go Limits are selectable by the BCD Upper Limit Converter card; the Lower No-Go Limits are selectable by the BCD Lower Limit

Converter. Digital program cards do not contain limit resistors when using BCD Limit Converter cards. Each Converter card contains three BCD digital to analog converters and a reference amplifier.

The Binary Coded Decimal system used by the converters includes four data lines per digit. Each digit automatically programs a zero (0) limit if no data line is grounded. Table 1 lists the proper data lines to ground for each number, from 0 through 9.

## OPERATING INSTRUCTIONS

### Type 262 Modification

Fig. 1 shows the leads that must be added to the Type 262 Programmer in order to use the Upper and Lower BCD Converter cards. Six of the leads connect the converter output to the Type 262 comparator card limit inputs. The other lead connects the Type 567 +20-volt supply to J302 so it can be patched back into the Converter cards along with other power supply leads.

TABLE 1

BCD Data Line Ground Code

Number	Lines Grounded
0	None
1	1
2	2 or 2'
3	1 and 2 or 1 and 2'
4	2 and 2' or 4
5	1, 2 and 2' or 1 and 4
6	2 and 4 or 2' and 4
7	1, 2 and 4 or 1, 2' and 4
8	2, 2' and 4
9	1, 2, 2' and 4

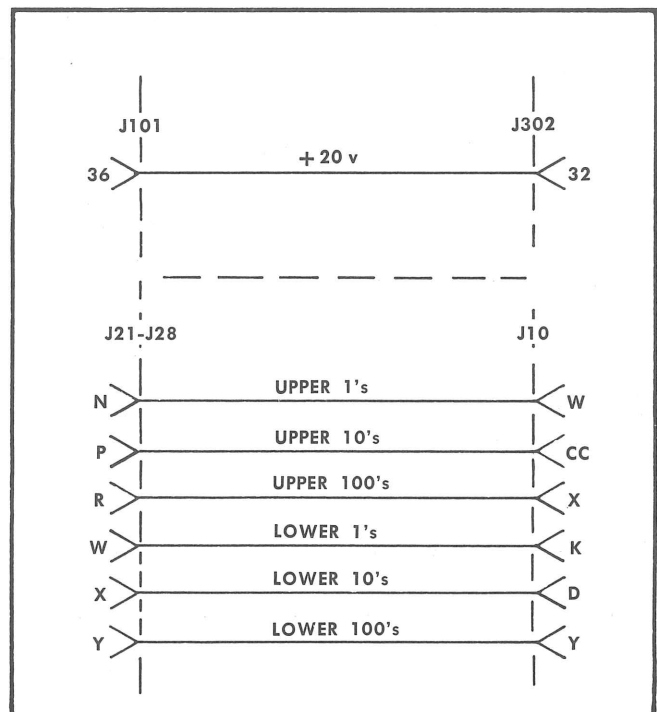

Fig. 1. Number 22 leads to be added inside the Type 262 when using BCD Limit Converters.

### Power Supply Connections

Power supply voltages are connected to the BCD Converters by jumper leads in P302. The connections inside P302 are diagrammed with the converter at the back of this manual. Number 22 insulated wire is adequate for jumpers in P302. P302 is a 36-pin plug which can be ordered from Tektronix by part no. 131-293.

## BCD Limit Converters

### BCD Input Connections

BCD data lines are connected to the Type 262 through P301-J301. P301-18 is the common ground return for all data closure switches. Table 2 lists the data lines by BCD code groups.

**TABLE 2**  
BCD Data Lines

BCD Code	Upper (472)			Lower (463)		
	1's	10's	100's	1's	10's	100's
1	14	19	23	1	5	9
2	15	20	24	2	6	10
2'	16	21	25	3	7	11
4	17	22	26	4	8	12

An example of ground connections for an upper limit of 472 and a lower limit of 463 requires the following P301 leads to be grounded: 24, 25; 19, 20, 22; and 15 for 472, and 10, 11; 6, 8; and 1, 2 for 463. The leads just named are shaded in Table 2. Any input sequence that obtains the same output is acceptable.

Connections can be by tape reader or other direct grounding device. Electronic grounding by saturated transistor is provided for by the +1.5-volt maximum voltage rating stated in the Characteristics.

## CIRCUIT DESCRIPTION

Each BCD decimal to analog converter group contains four input current-control transistors (limit setting matrix) and a stabilizer output amplifier. The amplifier output impedance is very low to assure stability of voltage levels sent to the Type 262 comparator card. The limit and lockout voltages of the Type 262 comparator card are identical to the conditions described in the Type 262 Instruction Manual (code date 664 or higher) at Table 3-2. The voltage difference between limit voltage and lockout voltage is the same as described in the note under Table 3-2 in the same Type 262 Instruction Manual.

### Current-Control Transistors

The input circuit to each Current-Control Transistor (Q4, Q14, etc.) saturates the transistor when the input circuit is not grounded. The emitter rests then at a very stable voltage difference (collector to emitter drop) from the +20-volt supply. The emitter resistor meters the current into the base of the stabilized amplifier.

Grounding the input circuit cuts off the current-control transistor so there is no current in its emitter resistor.

### Stabilized Amplifier Theory

The stabilized amplifier is sometimes called a feedback amplifier, or an operational amplifier. All the stabilized amplifiers are the same, so only Q44 and Q54 will be described. The voltage gain of Q44 alone is very high, but it drives an emitter follower whose emitter resistor is a feedback resistor back to the base of Q44. The voltage gain of

the stabilized amplifier is expressed as a ratio of the feedback resistance (R54) to the input resistance (R4, R14, R24, R34-R35). If a signal causes Q44 base to go negative, Q44 amplifies and inverts it, Q54 couples the inverted signal back to the input through R54, restoring the input voltage to be "nearly" as it was before the signal was applied. The input that caused the base to go negative then passes current through R4, and Q54 passes on equal current back through R54, so that the base of Q44 appears to be a virtual ground. Thus, if the input and feedback resistors were equal, an input signal at the input side of R4 of 20 volts, would cause an equal and opposite output signal of 20 volts. The current then through R4 and R54 would be equal. See Fig. 2.

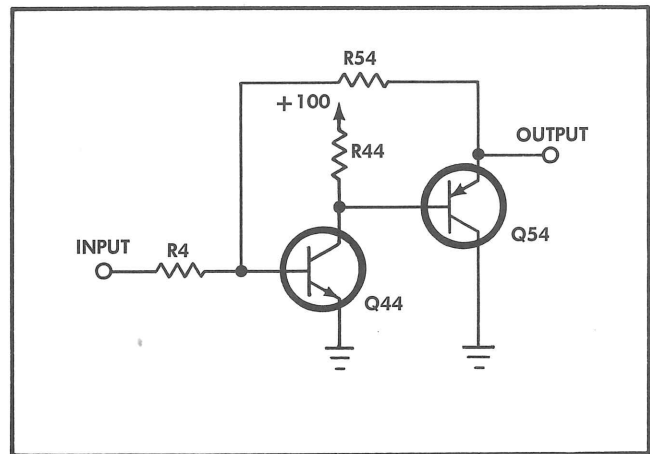

Fig. 2. Stabilized amplifier described in the text.

### Stabilized Amplifier Operation

The input resistors to Q44 are R4, R14, R24, R34-R35 and R42-R43. The emitter voltage of Q44 is slightly greater than 500 mv below ground. Assume all four input transistors are cut off and no current flows in R4, R14, R24 or R34-R35. The signal current is then from -25 volts through R42-R43 (assume 11.75 k), and the feedback current is through R54. Neglecting any small base current of Q44, and assuming Q44 base voltage to be +0.1 volt (silicon transistor normal 600 mv base-emitter voltage), the current through the input and feedback resistors is equal and the output voltage is +18.5 volts. Base current of Q44 and a correction in the value of R42 reduces the calculated figure to the actual value of 18.38 volts. The current through R42-R43 is about 2.12 ma, and remains at that value at all times.

As any input transistor saturates, the current through the associated input resistor cancels current from R42-R43, so that the feedback resistor current is reduced, reducing the output voltage. Assume a number 5 is required, and Q34 is the only saturated input transistor. The input resistor is now 25 k. The current from Q34 emitter to Q44 base is essentially 0.79 ma. R42-R43 current, minus 0.79 ma is 1.33 ma and is the current through the feedback resistor. Thus, the output voltage is about 11.52 volts. (Type 262 manual Table 3-2 says 11.66, the difference accounted for by assumptions here rather than measured values.)

### Reference Amplifier

In either of the preceding cases, if the Type 567 +20-volt supply changes voltage, Q54 output voltage will change. However, the Reference Amplifier (Q183) changes the emitter voltage of Q44 in the event of any change in the +20-volt supply, and prevents an output voltage change. Q183 also compensates for Q44 base-emitter voltage changes with changes in temperature.

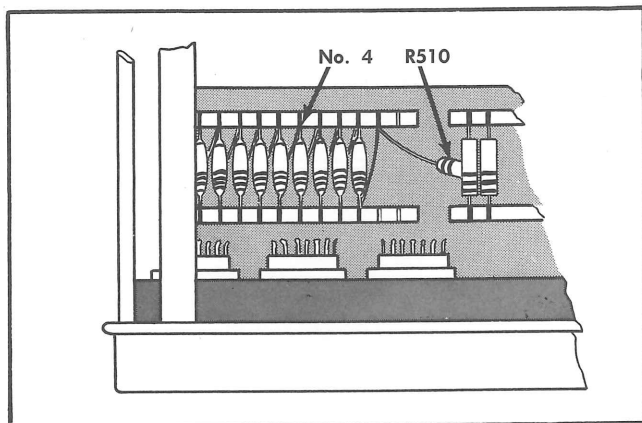

Fig. 3. Location of number 4 inside top of Type 6R1A (6R1).

### NOTE

All three systems on each Converter card operate as just described for the 1's converter. The 0.001  $\mu$ f capacitor at the base of Q54 prevents high-frequency oscillations of the stabilized amplifier.

### CALIBRATION PROCEDURE

The calibration of the BCD Limit Converter cards requires only a bench multimeter set to the 8- or 12-volt scale, and a small screwdriver. The adjustments should be made at the time of normal system calibration, or when changing either the Type 567, the Type 6R1A (6R1), or the Type 262, particularly if the power supply voltages are adjusted.

#### Procedure

Warm the system up 10 or 15 minutes. Program a number 4 limit in all 6 digits of the converters by grounding the 2 and 2' leads. One by one, place the test meter leads between each stabilized amplifier output and the number 4 point of the Type 6R1A limit divider string. (Fig. 3 diagrams the top of the Type 6R1A (6R1) showing the proper location for one of the meter leads.) The meter will read zero volts when R42, or R102, or R162 respectively, is adjusted correctly. That completes the calibration.

BCD Limit Converters

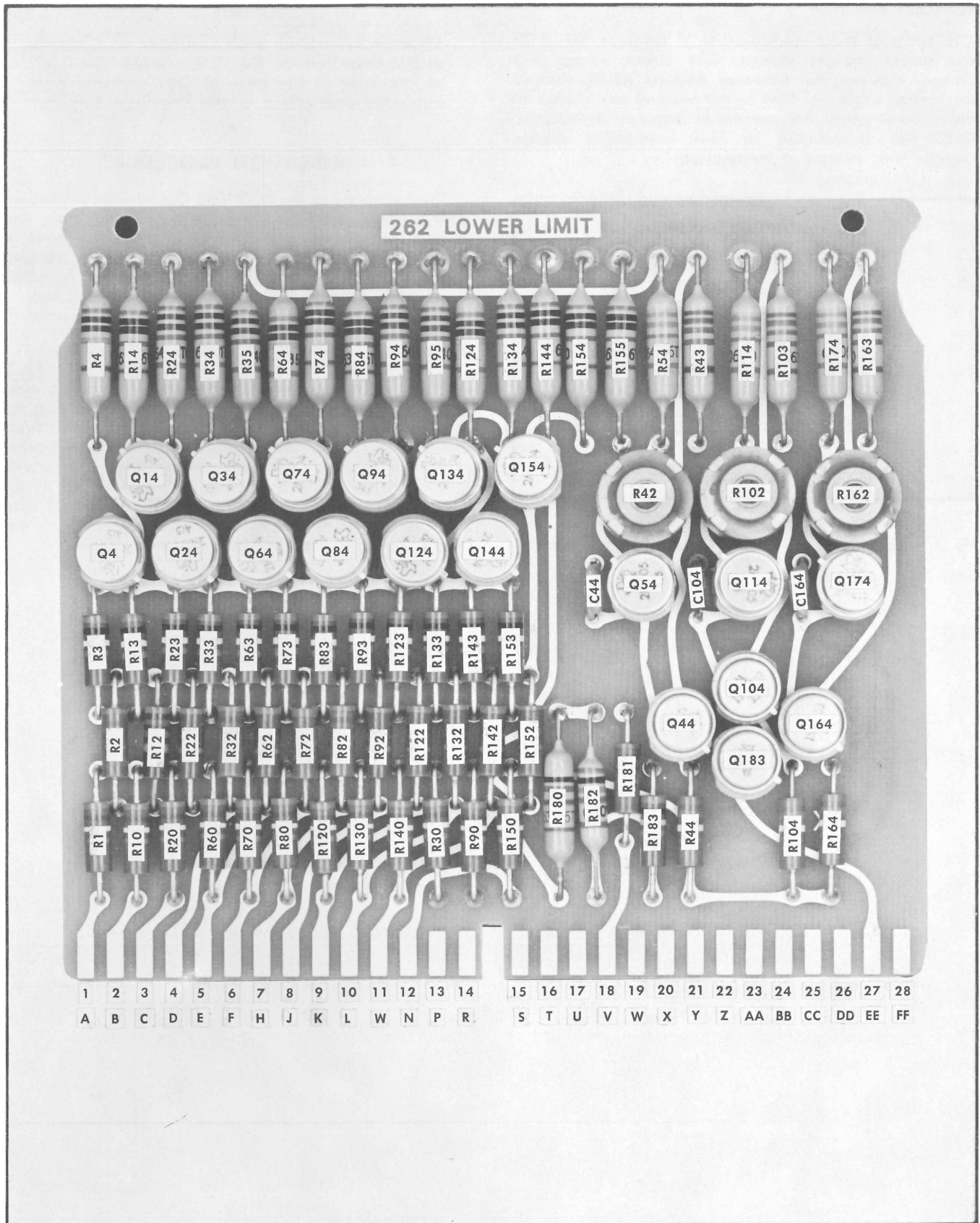

Fig. 4. BCD Lower Limit Converter parts locations. Complete card, Tektronix part no. 039-115.



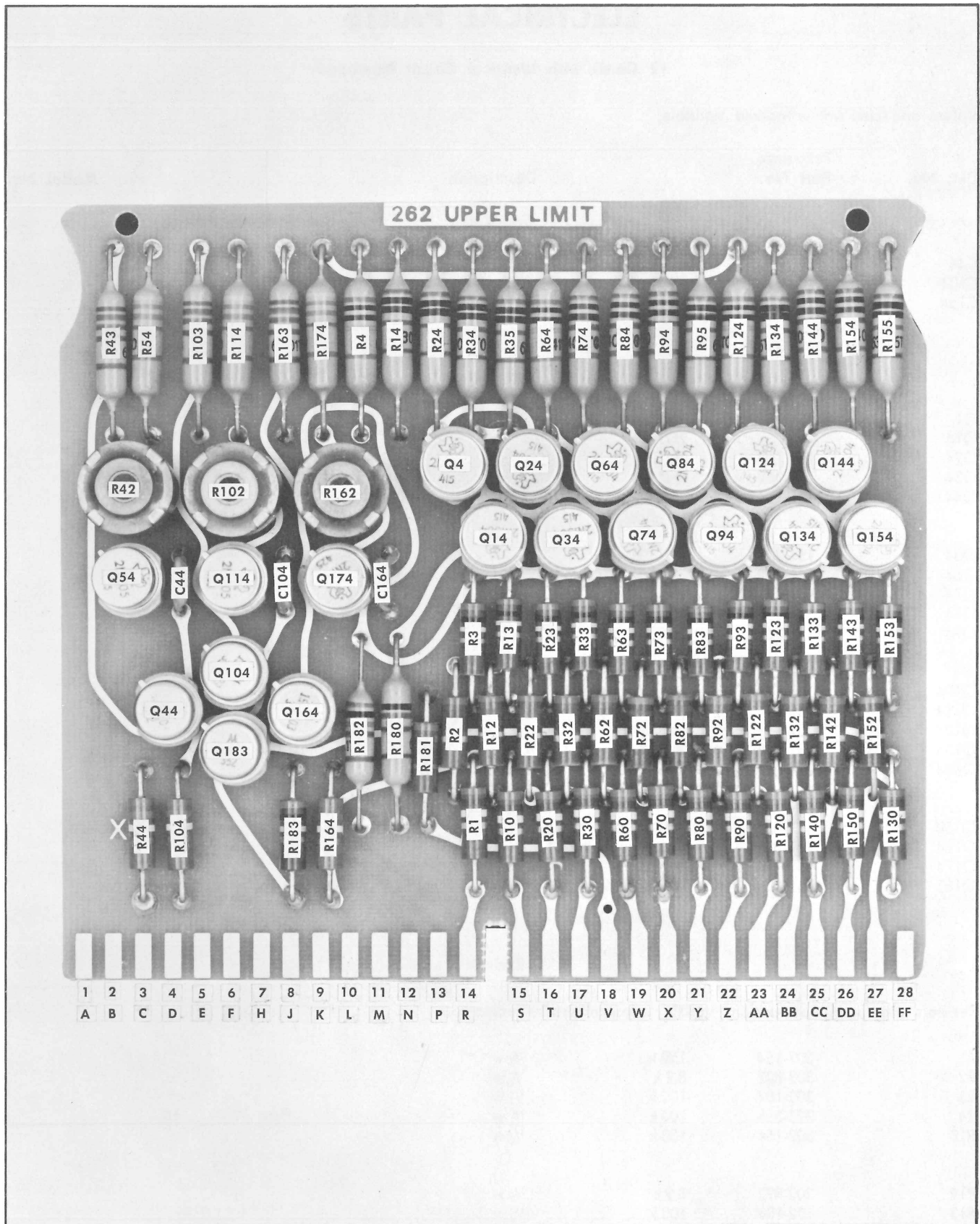

Fig. 5. BCD Upper Limit Converter parts locations. Complete card, Tektronix part no. 039-116.

## ELECTRICAL PARTS

(2 Cards with Identical Circuit Numbers)

Values are fixed unless marked Variable.

Ckt. No.	Tektronix Part No.	Description	Model No.
----------	--------------------	-------------	-----------

## Capacitors

C44	283-000	0.001 $\mu$ f	Cer 500 v
C104	283-000	0.001 $\mu$ f	Cer 500 v
C164	283-000	0.001 $\mu$ f	Cer 500 v

## Transistors

Q4	151-069	2N1304
Q14	151-069	2N1304
Q24	151-069	2N1304
Q34	151-069	2N1304
Q44	*151-103	Replaceable by 2N2219

Q54	151-071	2N1305
Q64	151-069	2N1304
Q74	151-069	2N1304
Q84	151-069	2N1304
Q94	151-069	2N1304

Q104	*151-103	Replaceable by 2N2219
Q114	151-071	2N1305
Q124	151-069	2N1304
Q134	151-069	2N1304
Q144	151-069	2N1304

Q154	151-069	2N1304
Q164	*151-103	Replaceable by 2N2219
Q174	151-071	2N1305
Q183	*151-103	Replaceable by 2N2219

## Resistors

Resistors are fixed, composition,  $\pm 10\%$  unless otherwise indicated.

R1	302-154	150 k	$\frac{1}{2}$ w		
R2	302-822	8.2 k	$\frac{1}{2}$ w		
R3	302-104	100 k	$\frac{1}{2}$ w		
R4	323-385	100 k	$\frac{1}{2}$ w	Prec	1%
R10	302-154	150 k	$\frac{1}{2}$ w		

R12	302-822	8.2 k	$\frac{1}{2}$ w		
R13	302-104	100 k	$\frac{1}{2}$ w		
R14	323-692	50 k	$\frac{1}{2}$ w	Prec	$\frac{1}{2}\%$
R20	302-154	150 k	$\frac{1}{2}$ w		
R22	302-822	8.2 k	$\frac{1}{2}$ w		



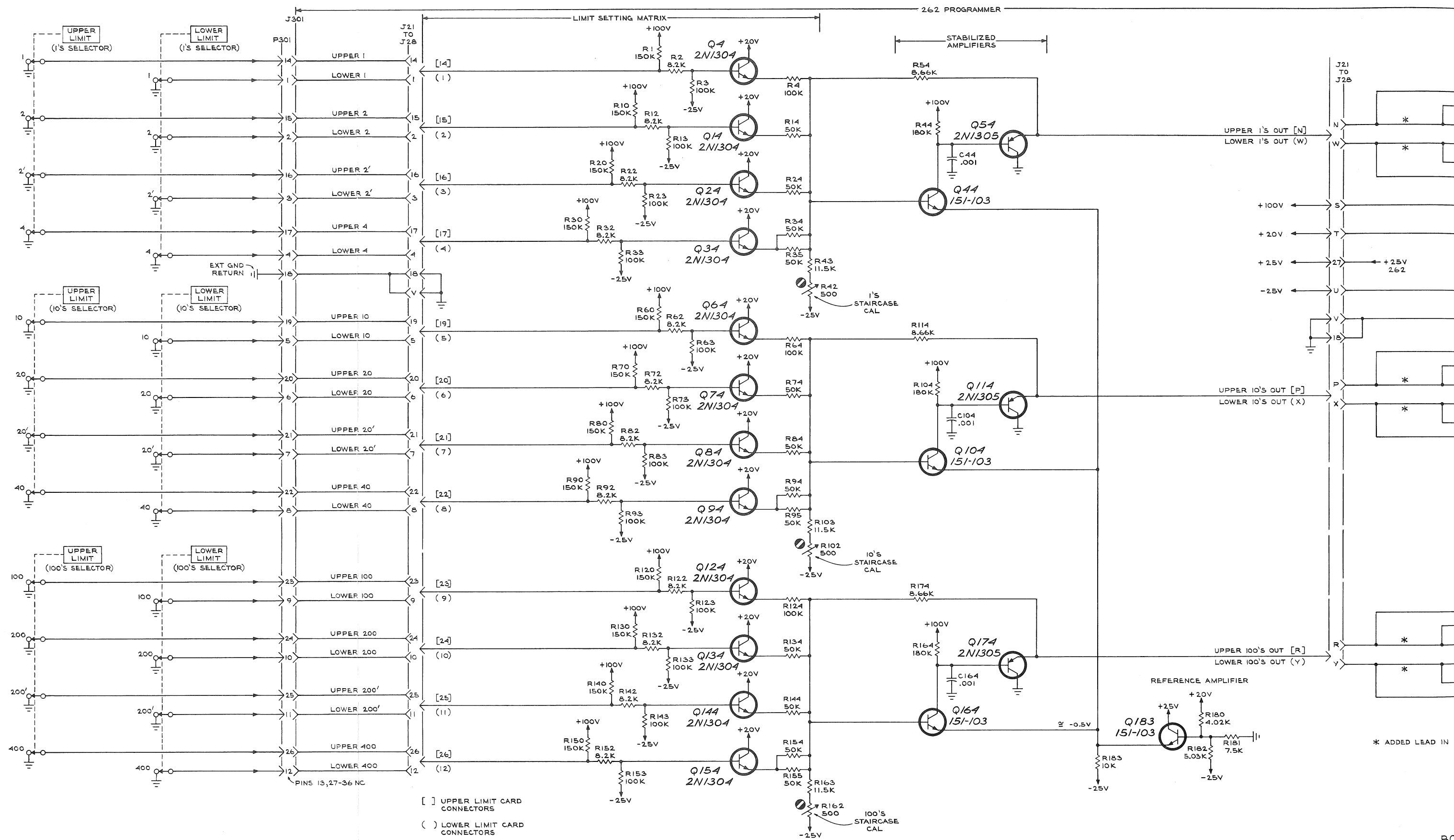

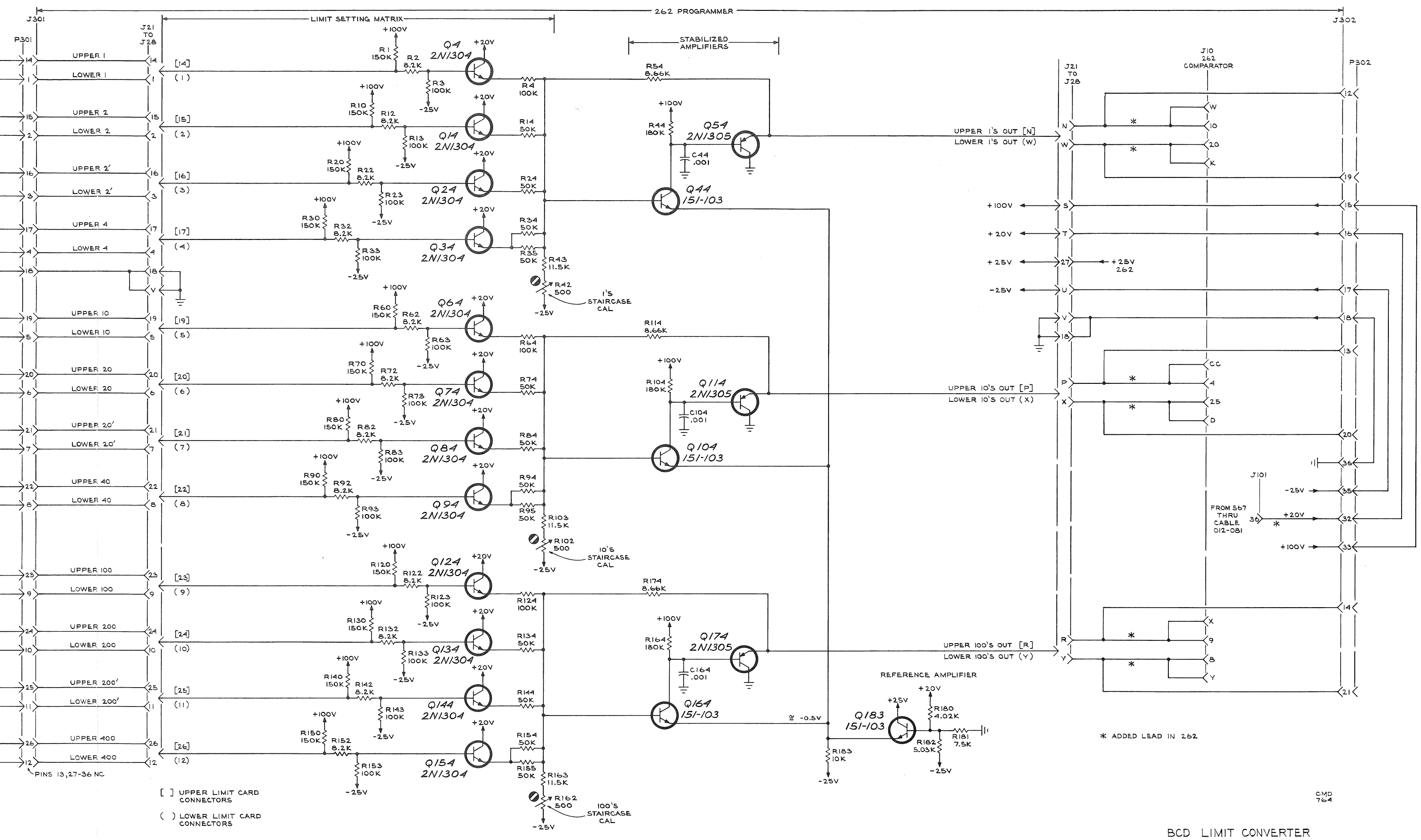

[ ] UPPER LIMIT CARD CONNECTORS  
 ( ) LOWER LIMIT CARD CONNECTORS

CMD 764

BCD LIMIT CONVERTER