

Instrument Serial Number:



®

FOR SERVICING AND SPARES ENQUIRIES  
SEE THE INFORMATION AT START OF SECTION 5.

TELEQUIPMENT is a registered trade mark of TEKTRONIX U.K. LTD.

TEKTRONIX U.K. LTD  
313 Chase Road  
Southgate,  
London N14 6JJ  
ENGLAND.

Telephone  
01-882 6100  
Telex: 262004  
Cables:  
TELEQUIPT LONDON N14

TEKTRONIX INC.,  
P.O. Box 500  
Beaverton,  
Oregon (97005)  
U.S.A.

Telephone  
(503) 644-0161  
Telex: 36 0485  
Cables:  
TEKTRONIX

## DUAL TRACE AMPLIFIER UNIT TYPE V4

### INSTRUCTION MANUAL

Issue 12  
July 1979  
© Copyright (1976) by  
Tektronix U.K. Ltd



INSTRUMENT V4		MANUAL PART NUMBER 070-1495-04	ISSUE 12	AMENDMENT LIST 3	
S.O. NUMBER	BATCH NUMBER	DATE 22nd April 1980		PAGE 1	OF 2
DESCRIPTION OF AMENDMENT				STARTING SERIAL NUMBER	
(1) Page 1/1  CHANGE to read 3dB bandwidth x1 x5 5mV - 20V/div 50MHz 15MHz REMOVE 5V - 20V/div 20MHz 12MHz				Manual Corrections	
(2) Page 5/2 †See Figure overleaf.  C610 - CHANGE to read 285-0887-00 ln5 125V †C620 - CHANGE to read 285-0887-00 ln5 125V *C900 - CHANGE to read 281-0804-00 CER ±0.5p 400				759899 759899 Manual Correction	
(3) Page 5/4 Fig. 1  *R908 - CHANGE to read 317-0100-01 10 CF				Manual Correction	
(4) Page 5/5  TR752 - CHANGE Pt. No. to read 151-0242-00  REMOVE - Attenuator CH2 CHANGE - Attenuator CH1 to *Attenuator Assy CHANGE - Pt. No. to read 011-0114-04 ADD -*Two per unit				Manual Correction  Manual Corrections	
(5) Page 5/6  Item 34 - Should read Cam Assembly 401-0193-02 Item 40 - Pt. No. should read 407-1083-02				Manual Correction	
TEKTRONIX UK LTD., TELEQUIPMENT DIV., 313 CHASE ROAD, SOUTHGATE, LONDON, N14 6JJ					

MANUAL/A.L. V4 AL 3

†Part Of Figure (2)

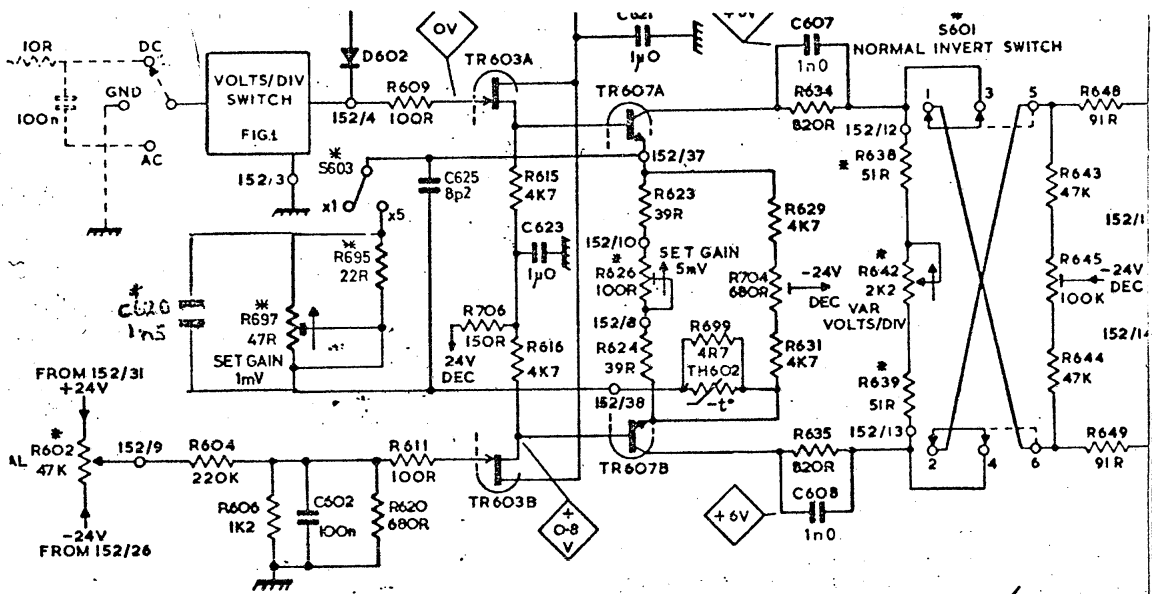

# INTRODUCTION

The V4, a 50 MHz dual-trace plug-in, provides the main frame with dual trace vertical facility, which displays either channel separately, adds channels algebraically, alternates or chops between channels.

This manual should be read in conjunction with the manuals of the associated units; e.g. Main-frame and Sweep units.

The high frequency performance of this plug-in is optimized in conjunction with main frame, thus interchanging plug-ins may necessitate minor readjustment, see Section 4. If no readjustment is made the overshoot roll-off may be up to 4%.

The design of this instrument is subject to continuous development and improvement, consequently minor changes from the information contained herein may be incorporated.

These changes which usually affect the Components Lists and Circuit Diagrams are described on Amendment Lists issued at regular intervals between manual reprints. Any Amendment List appertaining to this Manual is located in the pocket provided inside the back cover of this manual.

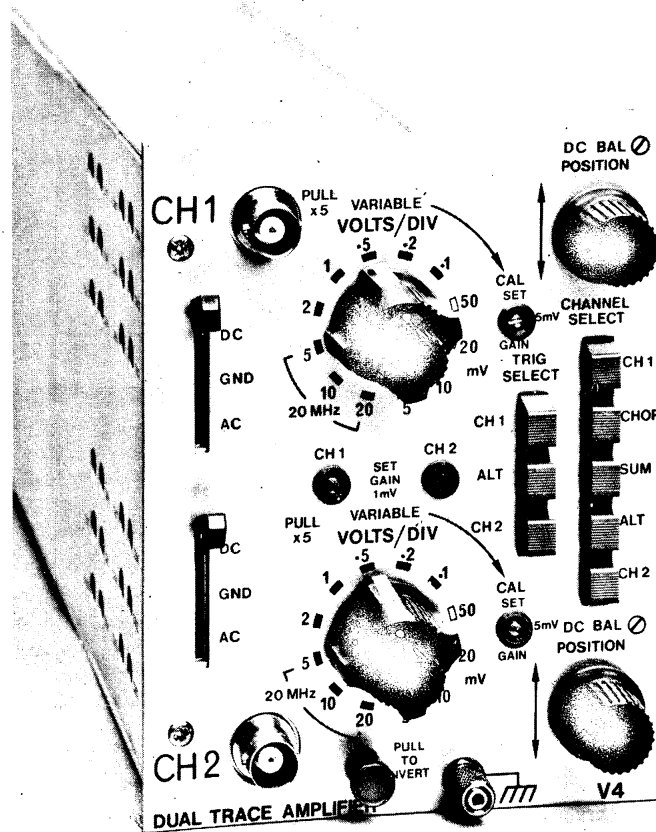

## NOTICE TO OWNER

To lessen the risk of damage during transit and to facilitate packaging, the owner is requested NOT to send the following items unless they are suspect, if this instrument is returned for servicing.

Probe

Plug Assemblies

# CONTENTS

SECTION	Page	SECTION	Page
<b>1 SPECIFICATION</b>		<b>Vertical Amplifier</b> . . . . .	4/1
Deflection Factors . . . . .	1/1	Balance . . . . .	4/1
Input Impedance . . . . .	1/1	Input . . . . .	4/1
Operating Mode . . . . .	1/1	General . . . . .	4/1
3 dB Bandwidth . . . . .	1/1	Mechanical . . . . .	4/1
		Access to Interior . . . . .	4/1
		Location of Preset Controls . . . . .	4/1
		Waveform . . . . .	Plate 4.1
<b>2 OPERATING INSTRUCTIONS</b>		<b>5 COMPONENT LISTS</b>	
Controls and Connectors . . . . .	2/1	Assemblies . . . . .	5/5
Connector . . . . .	2/1	Electrical . . . . .	5/1
Input . . . . .	2/1	Mechanical . . . . .	5/6
Output . . . . .	2/1	Exploded View . . . . .	5/7
Vertical Controls . . . . .	2/1		
Operation		<b>6 CIRCUIT DIAGRAM</b>	
Pre-operational checks . . . . .	2/1	Component Reference . . . . .	Figure 4
		PC137 . . . . .	
<b>3 CIRCUIT DESCRIPTION</b>		PC152 . . . . .	
Vertical amplifier . . . . .	3/1	PC153 . . . . .	
		Selector Switch . . . . .	Figure 3
<b>4 MAINTENANCE AND CALIBRATION</b>		Trigger . . . . .	Figure 3
Calibration . . . . .	4/1	Vertical Amplifier . . . . .	Figure 2
Initial Control Settings . . . . .	4/1	Volts/div . . . . .	Figure 1
Calibration Procedure . . . . .	4/1	Waveforms . . . . .	Plate 6.1
Attenuator . . . . .	4/1		
Controls . . . . .	4/1		

# SECTION 1

## SPECIFICATION

### 1.1 OPERATING MODE

Channel 1  
 Channel 2 (normal or inverted)  
 Channel 2 & 2. Summed.  
 Alternate  
 Chopped (at 350 kHz)

3 dB bandwidth  
 5 mV – 2 V/div  
 5 V – 20 V/div  
 Risetime  
 Sensitivity

X1  
 50 MHz  
 20 MHz  
 7 ns  
 5 mV to 20 V/div

X5  
 15 MHz  
 12 MHz  
 23 ns  
 1 mV to 4 V/div

#### Deflection factors

Calibrated (12 ranges 1.2.5 sequence)

5 mV – 20 V/div  $\pm 3\%$   
 1 mV – 4 V/div  $\pm 3\%$   
 1 M $\Omega$ , 33 pF in parallel  
 400 V D.C. + A.C. peak max.

Input impedance  
 Voltage  
 Trigger Sources

Channel 1 only  
 Channel 2 only  
 Alternative (from display signal)

#### Channel – Channel

Breakthrough

> 34 dB up to 50 MHz

# SECTION 2

## OPERATING INSTRUCTIONS

### 2.1 FUNCTION OF CONTROLS AND CONNECTORS

These are situated on the front panel except where otherwise specified. For those controls not covered below, reference should be made to Section 2, in the manuals for the Main Frame and Sweep Unit plug-in.

- 2.1.1 CRT** Mainframe Manual.
- 2.1.2 SWEEP** Sweep Unit Manual
- 2.1.3 TRIGGER** Sweep Unit Manual
- 2.1.4 VERTICAL DC-GND-AC** selects the input signal coupling. In the DC position, the signal from the CH1/CH2 connector is coupled directly to the attenuator. In the AC position a capacitor is inserted in series. In the GND position the input to the attenuator is grounded, and the input socket is isolated; this position enables the 0 V D.C. level of a trace to be ascertained.
- VOLTS/DIV** provides twelve steps of attenuation of each channel's input signal. Calibrated sensitivities are only valid when VARIABLE is fully clockwise.
- SET GAIN**  
5 mV  
1 mV  
a preset; adjusts X1 gain calibration.  
a preset; adjusts X5 gain calibration.  
**NOTE:** VARIABLE should be fully clockwise.
- VARIABLE** enables all deflection sensitivities between that selected by the VOLTS/DIV switch and the next below to be covered. When pulled magnifies the display 5 times in the vertical axis. The control must be fully clockwise for a calibrated display.
- INVERT** the setting of this button determines whether the CH2 signal is displayed in the same polarity as the input signal or inverted. The inverted setting is used to display the difference between two signals of the same phase in the SUM mode.
- TRIG SELECT** selects triggering from either channel or display.
- POSITION** moves the respective trace in the vertical axis.
- DC BAL** preset, adjusted to eliminate trace movement when the respective VARIABLE are pulled.

### CHANNEL SELECT

**CH1** selects Channel 1.

**CHOP** the channels are alternately switched on and off at a frequency of about 350 kHz; this mode is suitable for lower sweep speeds. When X5 gain is used HF/REJ should be selected on sweep plug-in.

**SUM** the display is the addition of the individual signals. If INVERT is pulled, the resultant display is the difference between two input signals.

**ALT** each channel is alternately displayed for the duration of a sweep. the ALT mode is preferable at higher sweep speeds.

**CH2** selects Channel 2.

### 2.1.5 CONNECTORS INPUTS

BNC sockets connect the signal to be viewed to the respective vertical amplifier.

**OUTPUTS** terminal connected to the chassis of the instrument.

**INTERFACE** edge connector situated at the rear; connects with mother-board in the main frame.

### 2.2 PRE-OPERATIONAL CHECKS

**NOTE:** Reference should be made to the Mainframe and Sweep Unit manuals for control settings and operation.

#### 2.2.1 POWER SUPPLY See Mainframe manual

#### 2.2.2 CONTROL SETTINGS

1. CRT See Mainframe manual
2. Sweep Unit plug-in. See Sweep Unit manual
3. Set controls as follows:

TRIG SELECT	CH1
CHANNEL SELECT	CH1
POSITION	Central
VOLTS/DIV	5 mV
INVERT	depressed
VARIABLE	fully clockwise
DC-GND-AC	GND
INPUT CONNECTION	CH1

### 2.3 OPERATION See Mainframe Manual.

# SECTION 3

## CIRCUIT DESCRIPTION

### 3.1 VERTICAL AMPLIFIER

The V4 plug-in consists of 2 amplifiers, which are switched in various ways to feed a single main amplifier in the main frame.

**3.1.1** The input attenuators, reference Figure 1, are simply capacity compensated L type sections which are switched singly or in cascade to obtain the correct attenuation. The sections on the two rear wafers of the attenuator are the -1, -2 and -4; on the front two wafers are the -10, -100 and -1000. The input impedance of the attenuator is maintained at 1 M $\Omega$  and 29 pF on all positions. The attenuators are identical electrically.

The DC-GND-AC switches select either a through connection on DC, a capacitor coupled connection via a 0.1  $\mu$ F 400 V capacitor on AC or a GND connection with the signal path input open circuited and the amplifier input grounded.

**3.1.2** The circuits of channel 1 (CH1) and channel 2 (CH2) are very similar. CH1 is described below with reference to Figure 2, except where reference is made to CH2. TR601A and TR601B are a matched pair of FETS used as source followers which drive TR605A and TR605B a phase-splitting stage. These are a long-tailed pair with the 1 mV and 5 mV SET CAL potentiometers, R696 and R625 in the emitter circuit. DC BAL R601, is adjusted to eliminate trace movement, when gain is switched. The collectors are connected to a shunt feedback stage, TR609 and TR611 via the variable VOLTS/DIV circuitry. The input impedance of this stage is very low and its total input resistance, including the 91  $\Omega$  resistors R646 and R647, is approximately 100  $\Omega$  per side. When the variable VOLTS/DIV potentiometer is at maximum resistance, the attenuation of the signal is small. When at minimum, however, the resistance is approximately 51  $\Omega$ /side. The attenuation of the signal is now approximately 3. This covers the gaps in the 1-2-5 sequence in the attenuators. The shift or position signal is inserted at the bases of TR609 and TR611, after the VARIABLE control. This ensures that the same amount of shift is obtained regardless of VARIABLE setting.

**3.1.3** The emitter followers TR614 and TR615 provide a low output impedance for the trigger pick-off and a low capacity loading for the shunt feedback stage. The CH1 trigger signal is fed to the bases of TR756 and TR757, which are a long-tailed pair then from their collectors, via a diode matrix, to the main frame trigger interface. The diode matrix allows the trigger signals to be switched from CH1, CH2 or the displayed signal merely by changing DC levels, +24V switches the channel on and -24V off. The display or ALT trigger pick-off circuitry is on the main frame mother board. TR618 and TR619 are series feedback stages with HF peaking between their emitters. The voltage swing at their bases is approximately 22 mV/div/side or 44 mV/div push-pull. Their collectors feed the main frame interface via the channel select diode matrix.

**3.1.4** When CH1 is selected, reference Figure 3, the voltage at eyelet 152/24 is taken to +11 V and at eyelet 152/23 to +15 V. This reverse biases D605, D606, D611 and D613 and switches on D612, D609, D607 and D608. The signal current now passes through D609 and D612. The interface voltage level is approximately +12.7 V and the interface current sensitivity is approximately 0.27 mA/div/side. This gives a voltage swing of 25 mV/div/side as the input impedance of the main frame is 100  $\Omega$ /side approximately.

**3.1.5** When CH2 is selected D612, D609, D607 and D608 are reverse biased and D605, D606, D611 and D613 are switched on. The signal current now flows in D611 and D613. Pin 152/24 is at +15V and pin 152/23 +11 V. On CHOP these levels are switched at approximately 350 kHz and on ALT sweep repetition rate. The switching signals are obtained from TR751 and TR753 collectors on PC153, eyelets 153/14 and 153/17. The switching levels are +11 V and +15 V. TR751 controls CH2 and TR753 CH1. The collectors and bases are cross-coupled to ensure bistable operation. When CH1 is selected the emitter of TR751 is open-circuited, thus switching it off and TR753 on. The reverse happens when CH2 is selected.

**3.1.6** When SUM is selected, both transistors are saturated and R771 is switched into circuit to reduce the current drain from the supply.

**3.1.7** On ALT, the circuit operates as a bistable, triggered by negative pulses from the sweep circuit. D751 and D753 are the steering diodes and C750 and C754 the input capacitors. The cross-coupling resistors R756 and R761 are non-symmetrical to ensure that the circuit does not achieve a third stable state with both collectors resting at +13.5 V due to low common mode gain.

**3.1.8** On CHOP, the circuit operates as an emitter-coupled multi-vibrator. R757, C751, C752 and R762 form the timing circuit and C753 provides a blanking pulse output at twice the chop frequency. TR752 is the blanking amplifier and shaper giving a current pulse via D752 to the main frame interface.

**3.1.9** CH2 has an invert facility, a 2-pole change-over switch, S601, which re-routes the signal current when the invert knob is pulled. On CH1, the R703 is used to eliminate trace movement, when operating the VARIABLE. On CH2 the R704 is used to equalize the currents through the two switch paths, so that no movement occurs on normal invert operation. R645 provides the balance control for the VARIABLE movement and R602 the balance control for gain switch movement. The CH2 trigger signal is fed to the bases of TR758 and TR759 then through the diode matrix to the main frame interface.



# SECTION 4

## MAINTENANCE AND RE-CALIBRATION

### 4.1 GENERAL

**4.1.1** This manual should be read in conjunction with the manuals for the main frame and plug-in in use.

**4.1.2** Before it is assumed a fault condition exists, control settings should be verified with reference to the pre-operational checks, para 2.2. Where components are replaced, e.g., transistors, it is advised that the calibration checks detailed in para 4.4 be carried out.

### 4.2 MECHANICAL

**4.2.1 ACCESS TO INTERIOR**  
Withdraw plug-in and remove covers.

**4.2.2 LOCATION OF PRESET CONTROLS**  
Attenuator (PC137) and Vertical amplifier (PC152) are situated on the left. Trigger amplifier (PC153) on the right.

### 4.3 CALIBRATION

**4.3.1** The following procedure enables a calibration check of the unit to be accomplished. It is advised, that isolated adjustments are not made, due to risk of interaction with settings made in earlier checks. A functional check may be carried out as detailed in para 4.4 below, checking parameters are met, then proceeding to the next check. Adjustments, if made, should be minimal, except when setting-up procedures are referred to.

The following tools and facilities will be required.

#### TOOLS

Screwdrivers	Plain 4mm. blade Non-capacitive.
Fixture	Extension, flexible, 067-0688-00 rigid, 067-0689-00.
Adaptors	Screened c/w BNC Adaptors, BNC 3-way, Male/Female/Male, BNC/2 mm.

Normalizer or capacitance measuring facility 33 pF.  
Probe for voltage measurement (067-0552-00).

NOTE: Input signal voltages are peak to peak.

#### FACILITIES

Input Signals		
Sinewave		Squarewave
20 mV	50 kHz	
	50 kHz	25 mV 1 kHz 1%
		50 mV 1 kHz 1%
		100 mV 1 kHz 1%
		250 mV 1 kHz 1%
		500 mV 1 kHz 1%
		1 V 1 kHz 1%
		2.5 V 1 kHz 1%
15 MHz		5.0 V 1 kHz 1%
		25 V 1 kHz 1%
		50 V 1 kHz 1%
		25 mV 1 MHz H 10 ns risetime

### 4.3.2 INITIAL SETTING

- 1.1 Push INVERT
- 1.2 Set both DC-GND-Ac to GND.
- 1.3 Set both VOLTS/DIV to 5 mV.
- 1.4 Set both VARIABLES fully clockwise.
- 1.5 Push CH1 (Trig & Channel Select).
- 1.6 Set both POSITION controls to mid position.

NOTE: Reference should be made to Mainframe and Sweep Unit manuals for the respective initial control settings.

### 4.4 CALIBRATION PROCEDURE

#### 4.4.1 VERTICAL AMPLIFIER BALANCE

##### Set CH1 X5 balance

- 1.1 Push A ONLY, A AUTO.
- 1.2 Set 'A' TIME/DIV to 1 ms.
- 1.3 Adjust POSITION to centralize trace.
- 1.4 Pull VARIABLE for X5 magnification.
- 1.5 Adjust D.C. BAL to re-centralize trace.
- 1.6 Push VARIABLE.
- 1.7 Re-centralize trace with POSITION control.
- 1.8 Repeat last four operations until no movement occurs.

##### Set CH2 X5 balance

- 2.1 Set as in CH1 using corresponding CH2 controls.
- 2.2 Switch off instrument. Remove Vertical Unit.
- 2.3 Remove unit left-hand cover.
- 2.4 Connect unit to Mainframe via extension lead.
- 2.5 Lay unit on right-hand side giving access to PC152.
- 2.6 Switch on instrument.

##### Set CH1 Variable gain balance

- 3.1 Push CH1 TRIG and CHANNEL SELECT.
- 3.2 Rotate VARIABLE anticlockwise.
- 3.3 Adjust POSITION to centralize trace.
- 3.4 Turn VARIABLE fully clockwise.
- 3.5 Adjust R703 PC152 to re-centralize trace.
- 3.6 Repeat last four operations until no movement occurs.

##### Set invert balance

- 4.1 Adjust POSITION to centralize CH2 trace.
- 4.2 Pull INVERT and note new position of trace.
- 4.3 Adjust R704 PC152 to centralize trace between two positions.
- 4.4 Push INVERT.
- 4.5 Repeat operations until no movement occurs.

##### Set CH2 Variable gain balance

- 5.1 Set as in CH1 using corresponding CH2 controls and R645 PC152.
- 5.2 RE-CHECK CH2 X5 BALANCE.
- 5.3 RE-CHECK CH2 INVERT BALANCE.

##### Set CH1 Gain

- 6.1 Set TIME/DIV to 0.1 ms.
- 6.2 Set VOLTS/DIV to 5mV.
- 6.3 Select CH1.
- 6.4 Set DC-GND-AC to DC.
- 6.5 Apply 25mV 1 kHz squarewave to CH1.
- 6.6 Rotate SET GAIN 5mV.
- 6.7 Check amplitude ranges from <4.5 to >5.5 divisions.
- 6.8 Set amplitude to 5 divisions.
- 6.9 Turn VARIABLE fully anticlockwise.
- 6.10 Check amplitude <2.0 divisions.
- 6.11 Turn VARIABLE fully clockwise and pull.
- 6.12 Reduce input to 5mV.
- 6.13 Rotate SET GAIN 1mV.
- 6.14 Check amplitude ranges from <4.5 to >5.5 divisions.
- 6.15 Set amplitude to 5 divisions.
- 6.16 Disconnect signal.

##### Set CH2 gain

- 7.1 Set as in CH1 using corresponding CH2 controls.

##### Set CH1 trigger

- 8.1 Place unit on its left-hand side.
- 8.2 Remove cover to expose PC153.
- 8.3 Select CH1.
- 8.4 Set TIME/DIV to 5μs.
- 8.5 Set VOLTS/DIV to 5mV.
- 8.6 Set DC-GND-AC to DC.
- 8.7 Apply 25mV 50 kHz sinewave to CH1.

- 8.8 Push ALT (Trig).
- 8.9 Push DC on Sweep Unit.
- 8.10 Adjust LEVEL to start trace on vertical centre line.
- 8.11 Push CH1 (TRIG).
- 8.12 Adjust R797 PC153 to correct trigger point movement.
- 8.13 Disconnect signal.

**Set CH2 trigger**

- 9.1 Set as in CH1 using corresponding CH2 controls.
- 9.2 Adjust R798 PC153 to correct trigger movement.

**CH1 attenuator compensation**

- 10.1 Switch off instrument.
- 10.2 Remove extension lead and fit right-hand cover.
- 10.3 Connect unit to Mainframe via extension board (670-2864-00).
- 10.4 Switch on instrument.
- 10.5 Push A ONLY, AUTO.
- 10.6 Set TIME/DIV to 0.1µs.
- 10.7 Set DC-GND-AC to DC.
- 10.8 Select CH1.
- 10.9 Set VOLTS/DIV ranges as in table.
- 10.10 Set for flat response.
- 10.11 Apply 25mV 1kHz via input normalizer 33pF to CH1.

CH1 & CH2 Volts/Div Setting	Input Voltage	Adjust Trimmer PC137
5 mV	50 mV	C916
Remove input normalizer	—	—
10 mV	50 mV	C917
20 mV	100 mV	C918
50 mV	250 mV	C907
0.1 V	0.5 V	C915
0.2 V	1 V	C914
0.5 V	2.5 V	C906
5 V	25 V	C905
Apply input via X10 probe		Adjust probe trimmer
50 mV	0.5 V	C904
0.5 V	5 V	C903
5 V	50 V	C902

**CH2 attenuator compensation**

- 11.1 Set and adjust as in CH1 using corresponding CH2 controls.
- 11.2 Disconnect signal.
- 11.3 Switch off instrument.
- 11.4 Remove extension board and refit unit to instrument.
- 11.5 Switch on instrument.

**Set CH1 pulse response**

- 12.1 Select CH1 TRIG AND CHANNEL SELECT.
- 12.2 Set VOLTS/DIV to 5mV.
- 12.3 Set TIME/DIV to 0.1µs and push FINE.
- 12.4 Set DC-GND-AC to AC.

- 12.5 Apply 25mV 1MHz < 1ns risetime squarewave to CH1.
- 12.6 Adjust C616 and R688 PC152 for trace overshoot < 0.1 divisions.
- 12.7 Pull FINE for X10 magnification.
- 12.8 Adjust C614 PC152 for 10% – 90% risetime < 0.7 ± 0.1 div (Plate 4.1).
- 12.9 Disconnect signal.

**Set CH2 pulse response**

- 13.1 Set as in CH1 using corresponding CH2 controls.
- 13.2 Adjust C617 and R689 PC152 for trace overshoot.
- 13.3 Adjust C615 PC152 for risetime.

**Check CH1 X1 bandwidth**

- 14.1 Select CH1 TRIG AND CHANNEL SELECT.
- 14.2 Set TIME/DIV to 1ms.
- 14.3 Apply 50kHz sinewave to CH1.
- 14.4 Adjust generator to give 6 div display.
- 14.5 Switch generator to 50MHz.
- 14.6 Check amplitude > 4.2 div of display.

**Check CH1 X5 bandwidth**

- 15.1 Pull VARIABLE for X5 magnification.
- 15.2 Apply 50kHz sinewave to CH1.
- 15.3 Adjust generator to give 6 div display.
- 15.4 Switch generator to 15MHz.
- 15.5 Check amplitude < 4.2 div of display.
- 15.6 Disconnect signal.

**Check CH2 X1 bandwidth**

- 16.1 Check as for CH1 using corresponding CH2 controls.

**Check CH2 X5 bandwidth**

- 17.1 Check as for CH1 using corresponding CH2 controls.
- 17.2 Replace left-hand cover of unit.
- 17.3 Re-check CH1 and CH2 X5 BALANCE.

**Sum balance**

- 18.1 Select ALT (CHANNEL SELECT).
- 18.2 Set both DC-GND-AC to GND.
- 18.3 Set TIME/DIV to 1ms.
- 18.4 Centre both traces with POSITION controls.
- 18.5 Push SUM.
- 18.6 Adjust Sum Balance pot on Mainframe to centre trace.

Switch off instrument, secure units in Mainframe and replace main covers.

Switch on instrument to ensure that covers do not cause short circuit faults.

Switch off instrument and variable power supply.

Disconnect instrument from variable power supply.

Refers to para. 4.4.4 of 4.0

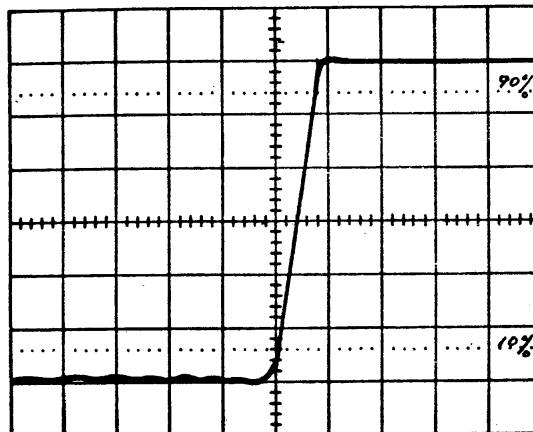

PLATE 4.1

# SECTION 5

## COMPONENT LIST

Values of resistors are stated in ohms or multiples of ohms; ratings at 70°C are in watts or sub-multiples of watts. Values of capacitors are stated in sub-multiples of farads; ratings at 70°C are in volts or kilovolts.

Whenever possible, exact replacements for components should be used, although locally available alternative may be satisfactory for standard components.

Any order for replacement parts should include:

- |                                |                          |
|--------------------------------|--------------------------|
| 1. Instrument type             | 4. Component part number |
| 2. Instrument serial number    | 5. Component Value       |
| 3. Component circuit reference |                          |

### CIRCUIT REFERENCE BLOCKS

The table below gives the blocks of circuit references, so that the reader can relate the items listed in this section and their location in the circuitry and printed circuit boards in Section 6.

Circuit Reference		Circuit	Fig.	P.C. Board No.
From	To			
601	700 )	Dual Trace Amplifier	( 2	152
751	800 )		( 3	153
901	950	Volts/Div Switch	1	137

### ABBREVIATIONS

BM Button mica	CMP Cermet preset	PS Polystyrene
C Carbon	E Electrolytic	Se Selenium
CP Carbon preset	Ge Germanium	Si Silicon
CV Carbon variable	MF Metal film	SM Silver mica
CER Ceramic	MO Metal oxide	WW Wire-wound
CT Ceramic trimmer	PE Polyester	WWP Wire-wound preset
CM Cermet thick film	PP Polypropylene	WWV Wire-wound variable

### TEKTRONIX U.K. LIMITED

36 - 38 Coldharbour Lane, Harpenden, Hertfordshire, England

Telephone: Harpenden 63141

Telex: 25559

All requests for repairs or replacement parts should be directed to the Tektronix Field Office or representative in your area. This procedure will assure you the fastest possible service.

CIR REF	PART NUMBER	VALUE F	DESCRIPTION TYPE	TOL %	RATING V	Eff. Ser.No.	CIR REF	PART NUMBER	VALUE F	DESCRIPTION TYPE	TOL %	RATING V	Eff. Ser.No.
C601	285-0915-00	100 n	PE	20	100		C756	281-0710-00	10 n	CER		250	
C602	285-0915-00	100 n	PE	20	100		C757	290-0623-00	4.7 μ	E		25	
C603	281-0710-00	10 n	CER		250		C758	285-0759-00	2.2 n	PS	5	125	
C604	285-1014-00	1 μ	PE	20	63								
C605	285-0858-00	1 n	PS	1	350	569001							
C606	285-0858-00	1 n	PS	1	350	569001							
C607	281-0858-00	1 n	PS	1	350	569001	C762	281-0731-00	5.6 p	CER	0.5p	750	
C608	285-0858-00	1 n	PS	1	350	569001	C763	281-0731-00	5.6 p	CER	0.5p	750	
C609	281-0710-00	10 n	CER		250								
C610	285-1064-00	680 p	PS	5	160	569751							
C611	281-0710-00	10 n	CER		250								
C612	281-0710-00	10 n	CER		250								
C613	281-0710-00	10 n	CER		250								
C614	281-0155-00	2-22 p	PP		500		*C900	285-0866-00	10 p	PS		350	
C615	281-0155-00	2-22 p	PP		500		*C901	285-0772-00	100 n	PE	10	400	
C616	281-0155-00	2-22 p	PP		500		*C902	281-0154-00	2-10 p	PPT		500	735301
C617	281-0155-00	2-22 p	PP		500		*C903	281-0155-00	2-22 p	PP		500	
C618	281-0710-00	10 n	CER		250		*C904	281-0155-00	2-22 p	PP		500	
C619	285-1014-00	1 μ	PE	20	63		*C905	281-0156-00	1.4-6.4 p	PP		500	
C620	285-1064-00	680 p	PS	5	160	567751	*C906	281-0156-00	1.4-6.4 p	PP		500	
C621	285-1014-00	1 μ	PE	20	63		*C907	281-0154-00	2-12 p	PP		500	
C622	285-1014-00	1 μ	PE	20	63		*C908	285-0872-00	180 p	PS	2	350	
C623	285-1014-00	1 μ	PE	20	63		*C909	283-0607-00	2 n	BM	10	500	
C624	281-0803-00	8.2 p	CER	± 0.5 p	400	759101							
C625	281-0803-00	8.2 p	CER	± 0.5 p	400	759101	*C911	283-0719-00	470 p	BM	10	500	
							*C912	281-0842-00	39 p	CER	± 5	400	
C750	285-0854-00	100 p	PS	2 p	350		*C914	281-0154-00	2-12 p	PP		500	
C751	285-0800-00	10 n	PE	20	250		*C915	281-0154-00	2-12 p	PP		500	
C752	285-0800-00	10 n	PE	20	250		*C916	281-0156-00	1.4-6.4 p	PP		500	
C753	285-0310-00	820 p	PS	5	125		*C917	281-0155-00	2-22 p	PP		500	
C754	285-0854-00	100 p	PS	2	350		*C918	281-0154-00	2-12 p	PP		500	
C755	285-0800-00	10 n	PE	20	250		*C919	283-0662-00	7.5 p	SM	0.5 p	350	
							*C921	285-1017-00	10 n	PE	20	500	
							C922	281-0804-00	10 p	CER	± 0.5 p	400	
							C923	281-0804-00	10 p	CER	± 0.5 p	400	

\*Two per unit.

CIR REF	PART NUMBER	VALUE	DESCRIPTION	TYPE	TOL %	RATING
D601	152-0565-00		EXP5072A	Si		
D602	152-0565-00		EXP5072A	Si		
D603	152-0543-00	5.1 V	Zener	Si	5	330 mW
D604	152-0545-00	10 V	Zener	Si	5	330 mW
D605	152-0554-00		BAY 74	Si		50 V
D606	152-0554-00		BAY 74	Si		50 V
D607	152-0554-00		BAY 74	Si		50 V
D608	152-0554-00		BAY 74	Si		50 V
D609	152-0062-01		1N914/1N4148	Si		75 V
D611	152-0062-01		1N914/1N4148	Si		75 V
D612	152-0062-01		1N914/1N4148	Si		75 V
D613	152-0062-01		1N914/1N4148	Si		75 V
D751	152-0062-01		1N914/1N4148	Si		75 V
D752	152-0062-01		1N914/1N4148	Si		75 V
D753	152-0062-01		1N914/1N4148	Si		75 V
D754	152-0062-01		1N914/1N4148	Si		75 V

CIR REF	PART NUMBER	VALUE	DESCRIPTION	TYPE	TOL %	RATING	Eff. Ser.No.
D755	152-0062-01		1N914/1N4148	Si		75 V	
D756	152-0062-01		1N914/1N4148	Si		75 V	
D757	152-0062-01		1N914/1N4148	Si		75 V	
D758	152-0062-01		1N914/1N4148	Si		75 V	
D759	152-0062-01		1N914/1N4148	Si		75 V	
D761	152-0062-01		1N914/1N4148	Si		75 V	
D762	152-0062-01		1N914/1N4148	Si		75 V	

CIR REF	PART NUMBER	VALUE ohms	TYPE	TOL %	RATING W	Eff. Ser.No.
*R601	311-1352-00	47 k	CV	20	250 m	
†R602	311-1352-00	47 k	CV	20	250 m	
R603	317-0224-01	220 k	C	5	125 m	
R604	317-0224-01	220 k	C	5	125 m	
R605	317-0122-01	1.2 k	C	5	125 m	
R606	317-0122-01	1.2 k	C	5	125 m	
R607	317-0101-01	100	C	5	125 m	
R608	317-0101-01	100	C	5	125 m	
R609	317-0101-01	100	C	5	125 m	
R610	317-0681-01	680	CF	5	125 m	735701
R611	317-0101-01	100	C	5	125 m	
R612	317-0472-01	4.7 k	C	5	125 m	
R613	317-0472-01	4.7 k	C	5	125 m	
R614	317-0103-01	10 k	C	5	125 m	
R615	317-0472-01	4.7 k	C	5	125 m	
R616	317-0472-01	4.7 k	C	5	125 m	
R617	317-0221-01	220	C	5	125 m	
R618	317-0221-01	220	C	5	125 m	
R619	317-0221-01	220	C	5	125 m	
R620	317-0681-01	680	CF	5	125 m	735701
R621	317-0390-01	39	C	5	125 m	
R622	317-0390-01	39	C	5	125 m	
R623	317-0390-01	39	C	5	125 m	
R624	317-0390-01	39	C	5	125 m	
R625	311-1350-00	100	CP	20	250 m	
R626	311-1350-00	100	CP	20	250 m	
R627	317-0512-01	5.1 k	C	5	125 m	
R628	317-0512-01	5.1 k	C	5	125 m	
R629	317-0472-01	4.7 k	C	5	125 m	
R631	317-0472-01	4.7 k	C	5	125 m	
R632	317-0821-01	820	C	5	125 m	
R633	317-0821-01	820	C	5	125 m	
R634	317-0821-01	820	C	5	125 m	
R635	317-0821-01	820	C	5	125 m	
R636	317-0510-01	51	C	5	125 m	
R637	317-0510-01	51	C	5	125 m	
R638	317-0510-01	51	C	5	125 m	
R639	317-0510-01	51	C	5	125 m	
**R641	311-1471-00	2.2 k	CV	20	250 m	
***R642	311-1471-00	2.2 k	CV	20	250 m	
R643	317-0473-01	47 k	C	5	125 m	
R644	317-0473-01	47 k	C	5	125 m	
R645	311-0765-00	100 k	CP	20	250 m	
R646	321-0968-48	91	MF	1	125 m	
R647	321-0968-48	91	MF	1	125 m	
R648	321-0968-48	91	MF	1	125 m	
R649	321-0968-48	91	MF	1	125 m	
R651	317-0472-01	4.7 k	C	5	125 m	
R652	317-0472-01	4.7 k	C	5	125 m	
R653	317-0472-01	4.7 k	C	5	125 m	

CIR REF	PART NUMBER	VALUE ohms	TYPE	TOL %	RATING W	Eff. Ser.No.
R654	317-0472-01	4.7 k	C	5	125 m	
*R655	311-1352-00	1.5 k	CV	20	250 m	
†R656	311-1352-00	1.5 k	CV	20	250 m	
R657	321-0862-48	620	MF	1	125 m	
R658	321-0862-48	620	MF	1	125 m	
R659	321-0862-48	620	MF	1	125 m	
R661	321-0862-48	620	MF	1	125 m	
R662	315-0621-02	620	C	5	250 m	
R663	315-0621-02	620	C	5	250 m	
R664	317-0361-01	360	C	5	125 m	
R665	317-0361-01	360	C	5	125 m	
R666	317-0471-01	470	C	5	125 m	
R667	317-0471-01	470	C	5	125 m	
R668	317-0471-01	470	C	5	125 m	
R669	317-0471-01	470	C	5	125 m	
R671	317-0272-01	2.7 k	C	5	125 m	
R672	317-0272-01	2.7 k	C	5	125 m	
R673	317-0272-01	2.7 k	C	5	125 m	
R674	317-0272-01	2.7 k	C	5	125 m	
R675	317-0100-01	10	C	5	125 m	
R676	317-0100-01	10	C	5	125 m	
R677	317-0220-01	22	C	5	125 m	
R678	317-0220-01	22	C	5	125 m	
R679	317-0220-01	22	C	5	125 m	
R681	317-0220-01	22	C	5	125 m	
R682	317-0162-01	1.6 k	C	5	125 m	
R683	317-0162-01	1.6 k	C	5	125 m	
R684	317-0162-01	1.6 k	C	5	125 m	
R685	317-0612-01	1.6 k	C	5	125 m	
R686	317-0151-01	150	C	5	125 m	
R687	317-0151-01	150	C	5	125 m	
R688	311-0717-00	220	CP	20	250 m	
R689	311-0717-00	220	CP	20	250 m	
R691	307-0394-00	3.9	C	5	125 m	
R694	317-0220-01	22	C	5	125 m	
R695	317-0220-01	22	C	5	125 m	
R696	311-1481-00	47	CP	20	250 m	
R697	311-1481-00	47	CP	20	250 m	
R698	307-0481-00	4.7	C	5	125 m	
R699	307-0481-00	4.7	C	5	125 m	1400
R701	317-0473-01	47 k	C	5	125 m	
R702	317-0473-01	47 k	C	5	125 m	
R703	311-0765-00	100 k	CP	20	250 m	
R704	311-0995-00	680	CP	20	250 m	
R705	317-0151-01	150	C	5	125 m	
R706	317-0151-01	150	C	5	125 m	

\*† Dual pot \*\* with S602 \*\*\*with S603

CIR REF	PART NUMBER	VALUE ohms	DESCRIPTION			RATING W	CIR REF	PART NUMBER	VALUE ohms	DESCRIPTION			Eff. Ser.No.
			TYPE	TOL %						TYPE	TOL %	RATING W	
R751	317-0103-01	10 k	C	5	125 m	R789	317-0151-01	150	C	5	125 m		
R752	317-0393-01	39 k	C	5	125 m	R791	317-0121-01	120	C	5	125 m		
R753	317-0470-01	47	C	5	125 m	R792	317-0121-01	120	C	5	125 m		
R754	317-0473-01	37 k	C	5	125 m	R793	317-0332-01	3.3 k	C	5	125 m		
R755	317-0621-02	620	C	5	250 m	R794	317-0332-01	3.3 k	C	5	125 m		
R756	317-0472-01	4.7 k	C	5	125 m	R795	317-0332-01	3.3 k	C	5	125 m		
R757	317-0821-01	820	C	5	125 m	R796	317-0332-01	3.3 k	C	5	125 m		
R758	315-0471-01	470	C	5	250 m	R797	311-0851-00	1 k	CP	20	250 m		
R759	317-0470-01	47	C	5	125 m	R798	311-0851-00	1 k	CP	20	250 m		
R761	317-0392-01	3.9 k	C	5	125 m	R799	317-0181-01	180	C	5	125 m		
R762	317-0821-01	820	C	5	125 m	*R900	317-0911-01	910	CF	5	125	735301	
R763	317-0470-01	47	C	5	125 m	*R901	317-0100-01	10	C	5	125 m		
R764	317-0103-01	10 k	C	5	125 m	*R902	321-0481-42	1 M	MF	0.5	125 m		
R765	317-0103-01	10 k	C	5	125 m	*R903	325-0124-00	990 k	MF	0.5	125 m		
R766	317-0123-01	12 k	C	5	125 m	*R904	325-0125-00	900 k	MF	0.5	125 m		
R767	317-0562-01	5.6 k	C	5	125 m	*R905	317-0470-01	47	C	5	125 m		
R768	315-0621-02	620	C	5	250 m							735301	
R769	307-0394-00	3.9	C	5	125 m	*R907	317-0331-01	330	C	5	125 m		
R771	315-0122-02	1.2 k	C	5	250 m	*R908	317-0150-01	15	C	5	125 m	670401	
R772	317-0473-01	47 k	C	5	125 m	*R909	321-0193-42	1 k	MF	0.5	125 m		
R773	317-0103-01	10 k	C	5	125 m	*R910	317-0301-01	300	CF	5	125 m	735301	
R774	317-0823-01	82 k	C	5	125 m	*R911	321-1289-42	10.1 k	MF	0.5	125 m		
R786	317-0151-01	150	C	5	125 m	*R912	321-1389-42	111 k	MF	0.5	125 m		
R787	317-0151-01	150	C	5	125 m	*R913	317-0470-01	47	C	5	125 m		
R788	317-0151-01	150	C	5	125 m	*R914	321-0970-42	500 k	MF	0.5	125 m		
						*R915	325-0126-00	750 k	MF	0.5	125 m		
						*R916	317-0470-01	47	C	5	125 m		
						*R917	321-0481-42	1 M	MF	0.5	125 m		
						*R918	316-0224-01	220 k	C	10	250 m		
						*R919	321-0481-48	1 M	MF	1	125 m		
						*R920	317-0100-01	10	CF	5	125 m	735301	
						*R921	321-0628-42	333 k	MF	0.5	125 m		

\* Two per unit

CIR REF	PART NUMBER	VALUE	DESCRIPTION	TYPE	TOL %	RATING
S601	260-1429-00		Slider normal invert			
S602	311-1471-00		Push-Pull (with R641)			
S603	311-1471-00		Push-Pull (with R642)			
S751	260-1406-00		Push (5 button)			
S752	260-1407-00		Push (3 button)			
*S901	260-1412-00		Lever (3 position)			
*S902	260-1409-00		Rotary (12 position)			
TH601	307-0403-00	4.7 $\Omega$	Thermistor		20	
TH602	307-0403-00	4.7 $\Omega$	Thermistor		20	

\* Two per unit

CIR	PART NUMBER	DESCRIPTION		TYPE
TR601A ) B )	151-1036-00	Dual fet	Si	N-channel
TR603A ) B )	151-1036-00	Dual fet	Si	N-channel
TR605A ) B )	151-0422-00	Dual MD2369B Motorola	Si	NPN
TR607A ) B )	151-0422-00	Dual MD2369B Motorola	Si	NPN
TR609	151-0421-00	MPS 918	Si	NPN
TR611	151-0421-00	MPS 918	Si	NPN
TR612	151-0421-00	MPS 918	Si	NPN
TR613	151-0421-00	MPS 918	Si	NPN
TR614	151-0421-00	ZTX320/MPS918	Si	NPN
TR615	151-0421-00	ZTX320/MPS918	Si	NPN
TR616	151-0421-00	ZTX320/MPS918	Si	NPN
TR617	151-0421-00	ZTX320/MPS918	Si	NPN
TR618	151-0127-03	BSX20	Si	NPN
TR619	151-0127-03	BSX20	Si	NPN
TR621	151-0127-03	BSX20	Si	NPN
TR622	151-0127-03	BSX20	Si	NPN
TR751	151-0127-02	BSX20/2N2369	Si	NPN
TR752	151-0246-00	2N3904	Si	NPN
TR753	151-0127-02	BSX20/2N2369	Si	NPN
TR756	151-0320-01	MPS65 18 Motorola	Si	PNP
TR757	151-0320-01	MPS65 18 Motorola	Si	PNP
TR758	151-0320-01	MPS65 18 Motorola	Si	PNP
TR759	151-0320-01	MPS65 18 Motorola	Si	PNP

### ASSEMBLIES

ASSEMBLY	PART NUMBER	INCLUDES CIRCUIT REFERENCES
Amplifier PC152	670-2557-00	C601 to C610, C611 to C618, C620, D601 to S609, D611 to D613, R603 to R624, R627 to R629, R631 to R635, R643 to R649, R651 to R654, R657 to R659, R661 to R669, R671 to R679, R681 to R689, R691, R694 to R699, R701 to R706, S601, TR601 to TR609, TR611 to TR619, TR621, TR622.
Attenuator CH1	011-0114-03	C901, C913, C921, PC137, R901, R905 to R907, R913 to R919, R921, S902.
Attenuator CH2	011-0114-02	C901, C913, C921, PC137, R901, R905 to R907, R913 to R919, S902.
PC137	670-2191-01	C902 to C909, C911, C912, C914 to C919, R902 to R908, R909, R911, R912.
Trigger PC153	670-2658-00	C750 to C759, C761 to C763, D751 to D759, D761, D762, R751, R752, R754 to R758, R761 to R765, R767 to R769, R771 to R779, R781 to R789, R791 to R798, S751, TR751, to TR753, TR756 to TR759

## MECHANICAL LIST

Item	Description	Part No.	Starting Ser. No.
1	Bar	381-0335-02	
2	Panel sub-front	386-2301-00	
3	Panel front	333-1765-03	
4	Bracket rear	407-1079-00	
5	Bracket pcb	407-1080-01	
6	Shield side	337-1661-01	
7	Shield side	337-1811-00	
8	Stop	105-0347-00	
9	Post terminal	129-0374-00	
10	Nut terminal	220-0647-00	
11	Solder tag 3/8" i/d	210-0275-00	
12	Screen input	337-1753-00	
13	Bearing	401-0165-00	
14	Plate name	334-1933-02	
15	Washer special	210-1177-00	
16	Rod cranked assembly	384-0843-00	
17	Spring clip	214-1817-00	
18	Nut chrome	220-0527-00	
19	Spacer	385-0206-00	
20	Panel bush	358-0460-00	
21	Knob assembly	366-1387-00	
22	Knob assembly	366-1254-00	
23	Knob assembly	366-1266-01	
24	Knob lever	366-0215-02	
25	Knob push-button	366-1403-00	
26	Knob push-pull	366-1404-00	
27	Screw skt hd cup point M3 x 3	213-0248-00	
28	Coupling	376-0137-01	
29	Rod extension	384-1142-15	
30	Coupling 1/8" - 1/8" / 4mm - 1/8"	376-0133-00	
		376-0147-00	
31	Rod extension	384-1142-01	
32	Coupling insulated	376-0137-02	
33	Rod extension	384-1142-11	
34	Cam	401-0193-00	
35	Screen pcb	337-1687-00	
39	Screen attenuator	337-1658-00	
40	Bracket	407-1083-01	
41	Cover	200-1373-00	
44	Solder tag 6BA	210-0297-00	
43	Strip earth contact	124-0358-00	
44	Extension shaft	384-1370-00	
50	Screw 8BA c'sk hd x 1/4"	213-0454-00	
51	Screw 8BA rd hd x 1/4" slot	213-0732-00	
52	Screw 6BA c'sk hd x 3/16"	213-0467-00	
53	Screw 6BA pan hd x 1/4"	213-0393-00	
54	Screw 6BA c'sk hd x 1/4"	213-0391-00	
55	Screw 6BA inst hd x 1/4" chrome	213-0644-00	
56	Screw 6BA c'sk hd x 5/16"	213-0404-00	
57	Screw 4BA pan hd x 1/4"	213-0388-00	
58	Screw 4BA c'sk hd x 5/16"	213-0387-00	
59	Screw s/t No 2 pan hd x 1/4"	213-0354-00	
60	Screw s/t No 2 c'sk hd x 1/4"	213-0353-00	
61	Screw s/t No 4 c'sk hd x 3/16"	213-0362-00	
64	Washer 6BA crinkle	210-1208-00	
65	Washer 3/8" i/d int shakeproof	210-1165-00	
68	Nut 6BA full	220-0716-00	



**B**

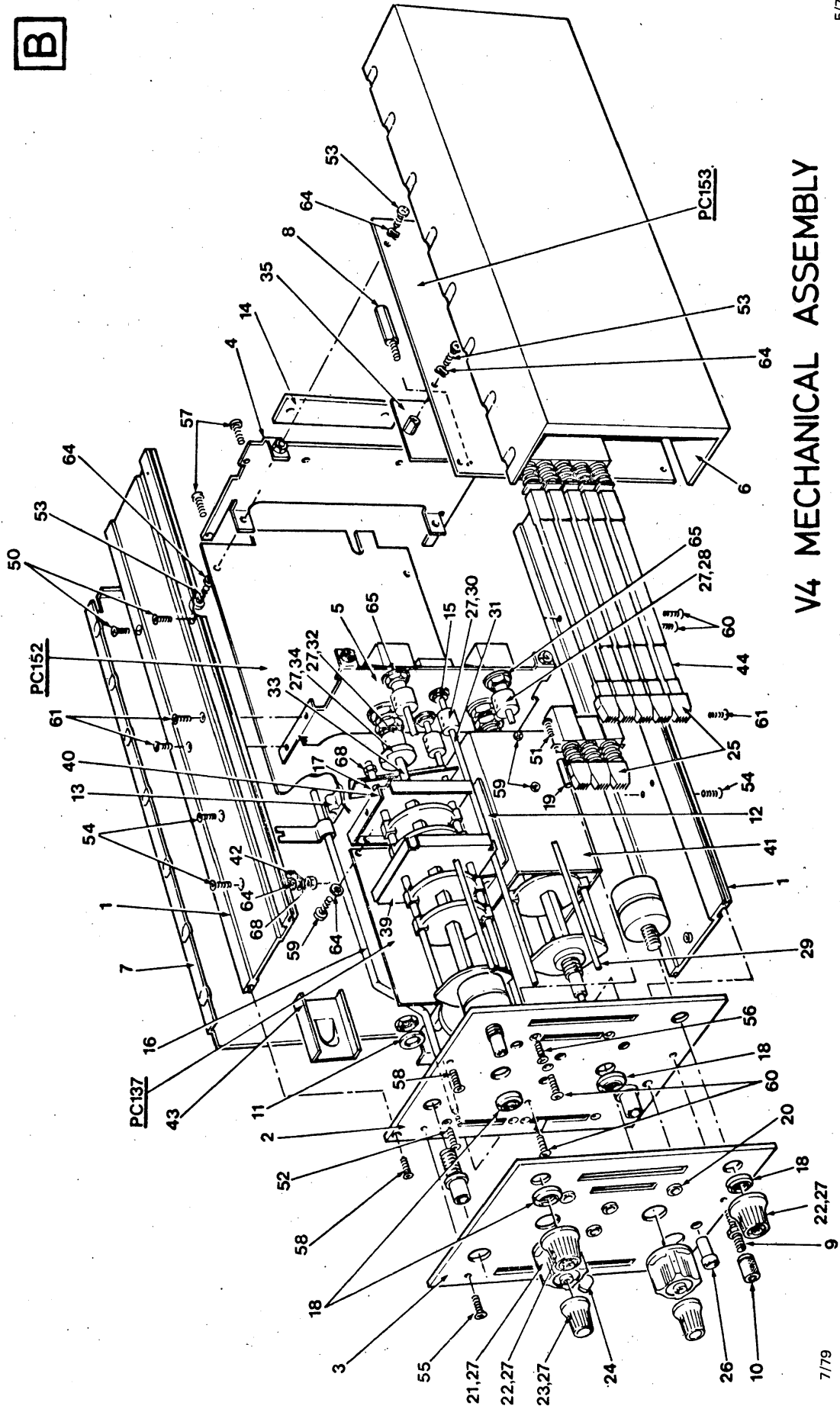

**V4 MECHANICAL ASSEMBLY**

## SECTION 6

To minimize the risk of misinterpretation of component values on circuit diagrams, the decimal point has been replaced by the multiplier or sub-multiplier of the basic unit. For instance, 2.2 megohms is shown as 2M2 and 1.8 picofarads is shown as 1p8.

To aid the reader further, in addition to the block Circuit Reference Table in Section 5.1, to locate a component in the circuit diagrams, a table is provided at the top of each circuit diagram, in which the circuit reference will appear, where practicable, directly above the component being sought.

### PRINTED CIRCUIT

Blue shows the rear track as seen through the board. Yellow the component side track.

Location of components are listed on the page preceding the PCBs.

### WAVEFORMS

Waveforms, illustrated in Plate 6/1, may be monitored at point with the corresponding number.

RESISTORS

901		910	900	902	903	907	909
				905	904	920	908
							911
							912
							913

CAPACITORS

901	902	900	905	906	907	908	909
	903					910	911
	904					912	

MISC.

S901	S902
------	------

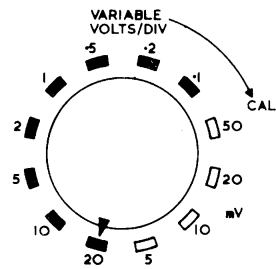
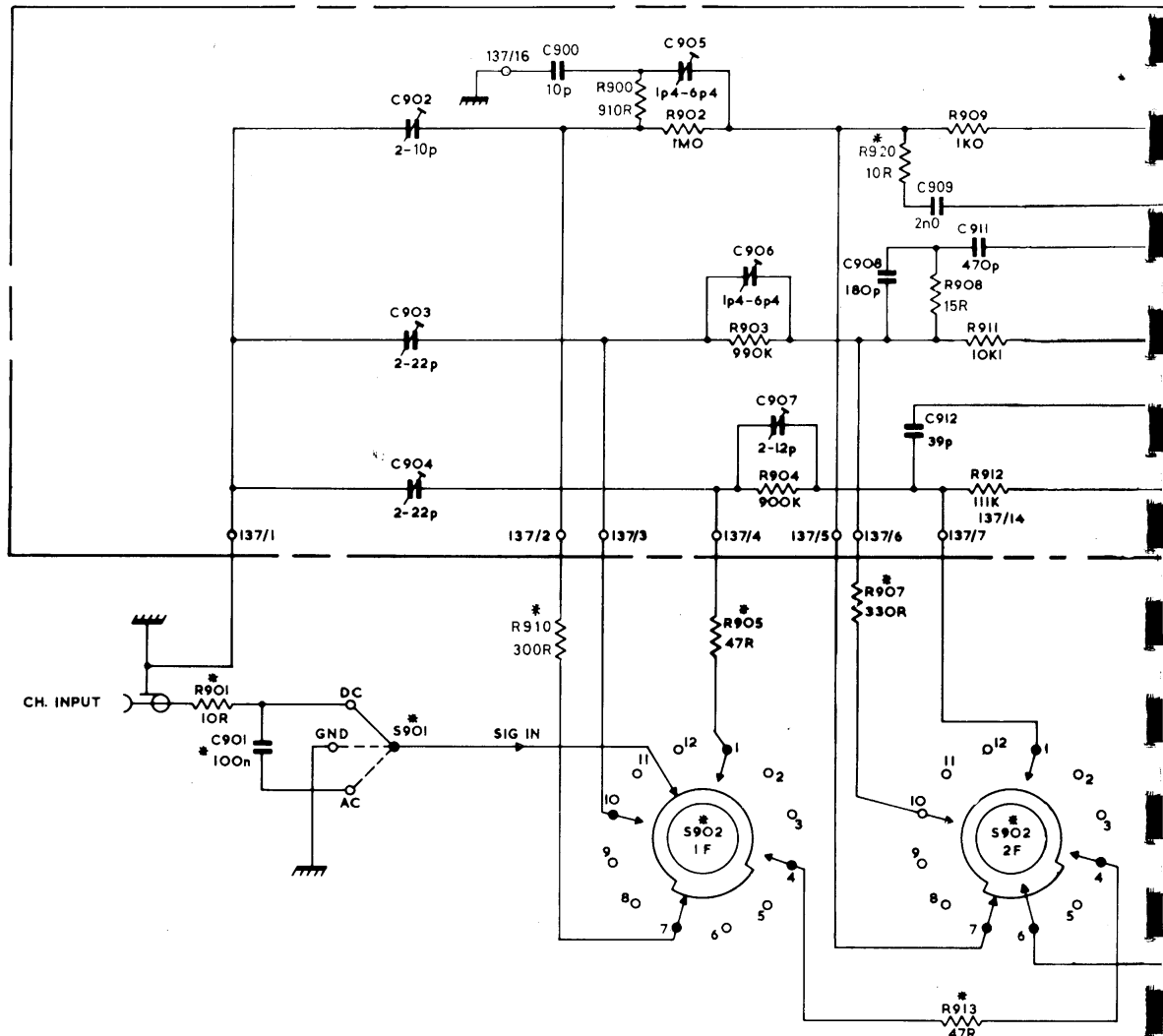

FRONT PANEL MARKING

NOTES.

1. 137/10 DENOTES PC BOARD/EYELET OR TERMINAL No.
2. \* DENOTES COMPONENTS NOT MOUNTED ON PC BOARD
3. SWITCH IS SHOWN IN FULLY ANTICLOCKWISE POSITION

914 922  
915 923  
916

917

914  
915

916

918

919

917

918

919

921

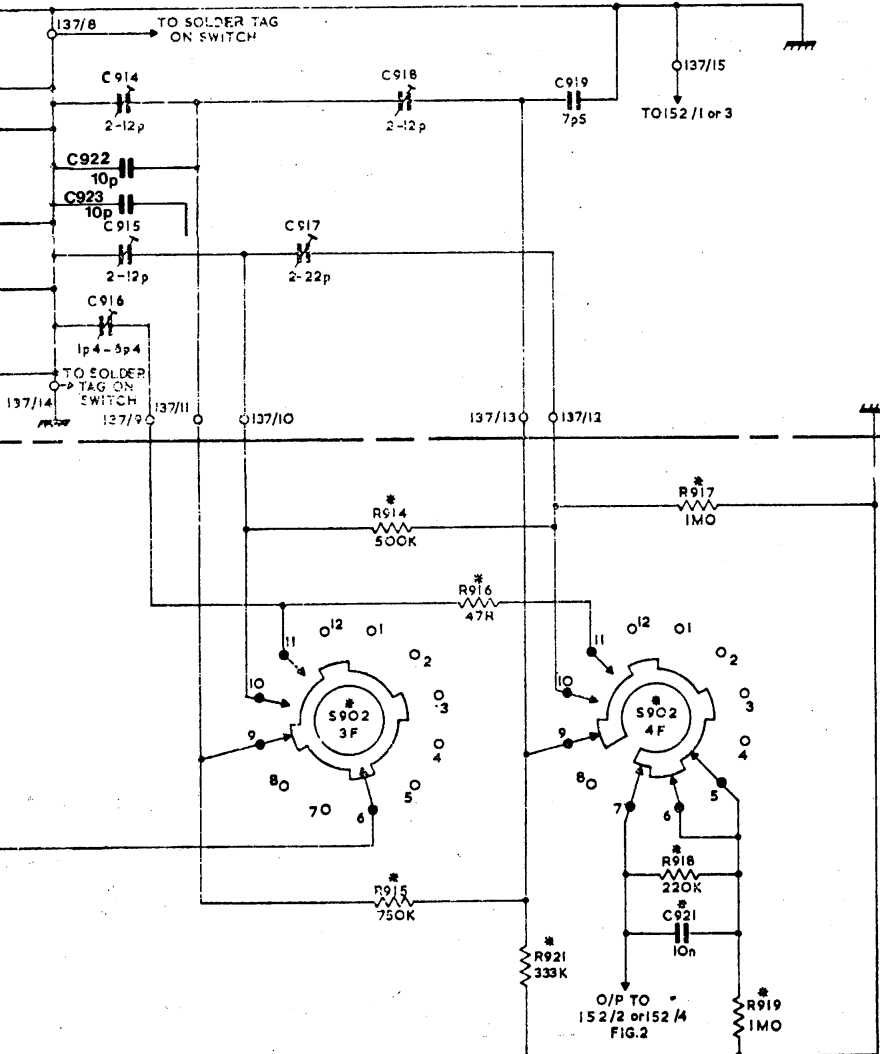

DUAL TRACE AMPLIFIER TYPE V4  
VOLTS/DIV SWITCH  
FIG.1

ATTENUATION SELECTED BY WAFER									
Switch Position	1	2	3	4	Selected Resistor			Selected Resistor	
					To Earth 1F	Eyelets and 2F	Between 3F and 4F	Between 4F and Earth	
20 V	Eyelet No.: 137/2	Eyelet No.: 137/5	Eyelet No.: 137/11	Eyelet No.: 137/13	R902 R909	R906	R915	R921 R919	
10 V	137/2	137/5	137/10	137/12	R902 R909	R906	R914	R917 R919	
5 V	137/2	137/5	137/9	—	R902 R909	R906	R916	R919	
2 V	137/3	137/6	137/11	137/13	R903 R908 R911	R907	R915	R921 R919	
1 V	137/3	137/6	137/10	137/12	R903 R908 R911	R907	R914	R917 R919	
0.5 V	137/3	137/6	137/9	—	R903 R908 R911	R907	R916	R919	
0.2 V	137/4	137/7	137/11	137/13	R905 R904 R912	—	R915	R921 R919	
0.1 V	137/4	137/7	137/10	137/12	R905 R904 R912	—	R914	R917 R919	
50 mV	137/4	137/7	137/9	—	R905 R904 R912	—	R916	R919	
20 mV	—	—	137/11	137/13	—	Resistor Between 1F & 2F R913	R915	R921 R919	
10 mV	—	—	137/10	137/12	—	R913	R914	R917 R919	
5 mV	—	—	137/9	—	—	R913	R916	R919	

TABLE — VOLTS/DIV SWITCH CONNEXIONS

RESIS
CAPAC
MISC.
SK601
SK602

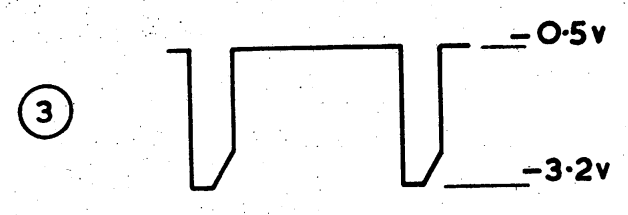
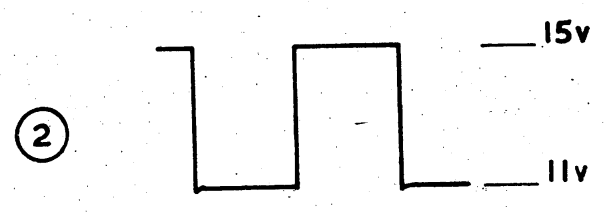
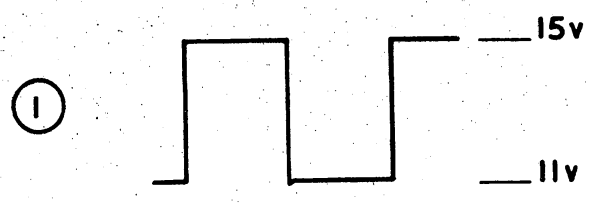
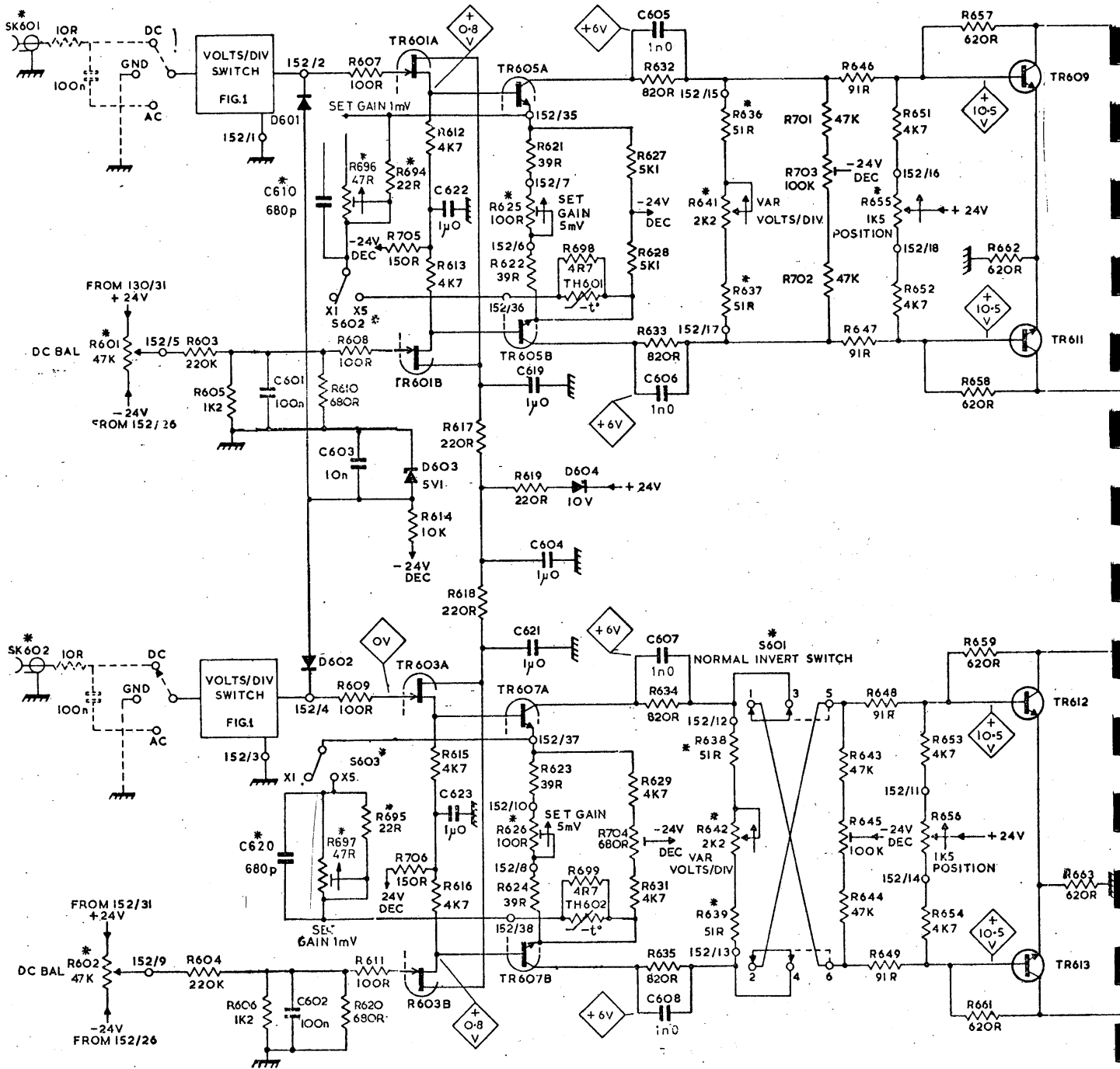

PLATE 6/1



RESISTORS	601	605	696	607 694 612 617	621	698 627	636	701 702	651	657
			608 705 613 618	625	699 628	641	703 646 655	658		
	602	603 604 606	609 695 619	622 623 624	704 629 631	637 638 642 635	643 647 652 653	659		
			614 616				645 648 656	661		
							644 649 654	662		663
CAPACITORS		601 603 622 623		619 604 621		605 606 607 608				
MISC.		D601 S602 D603	TR601A TR601B TR603A TR603B	TR605A TR605B TR607A TR607B	TH601 D604 TH602		S601			TR609 TR611 TR612 TR613
SK601 SK602										



- NOTES
- \* DENOTES COMPONENTS NOT MOUNTED ON PC BOARD.
  - 152/2 DENOTES PC BOARD/EYELET OR TERMINAL No.

666	671	675	677	682	686	688	
667	672	676	678	683	687	689	
668	673		679	684			691
669	664		681	685			
665							
609	612	614	616				
611	613	615	617	618			
TR614	TR618		D605				
TR615	TR619		D606				
TR616	TR621		D607	D609	D612		
TR617	TR622		D608	D611	D613		

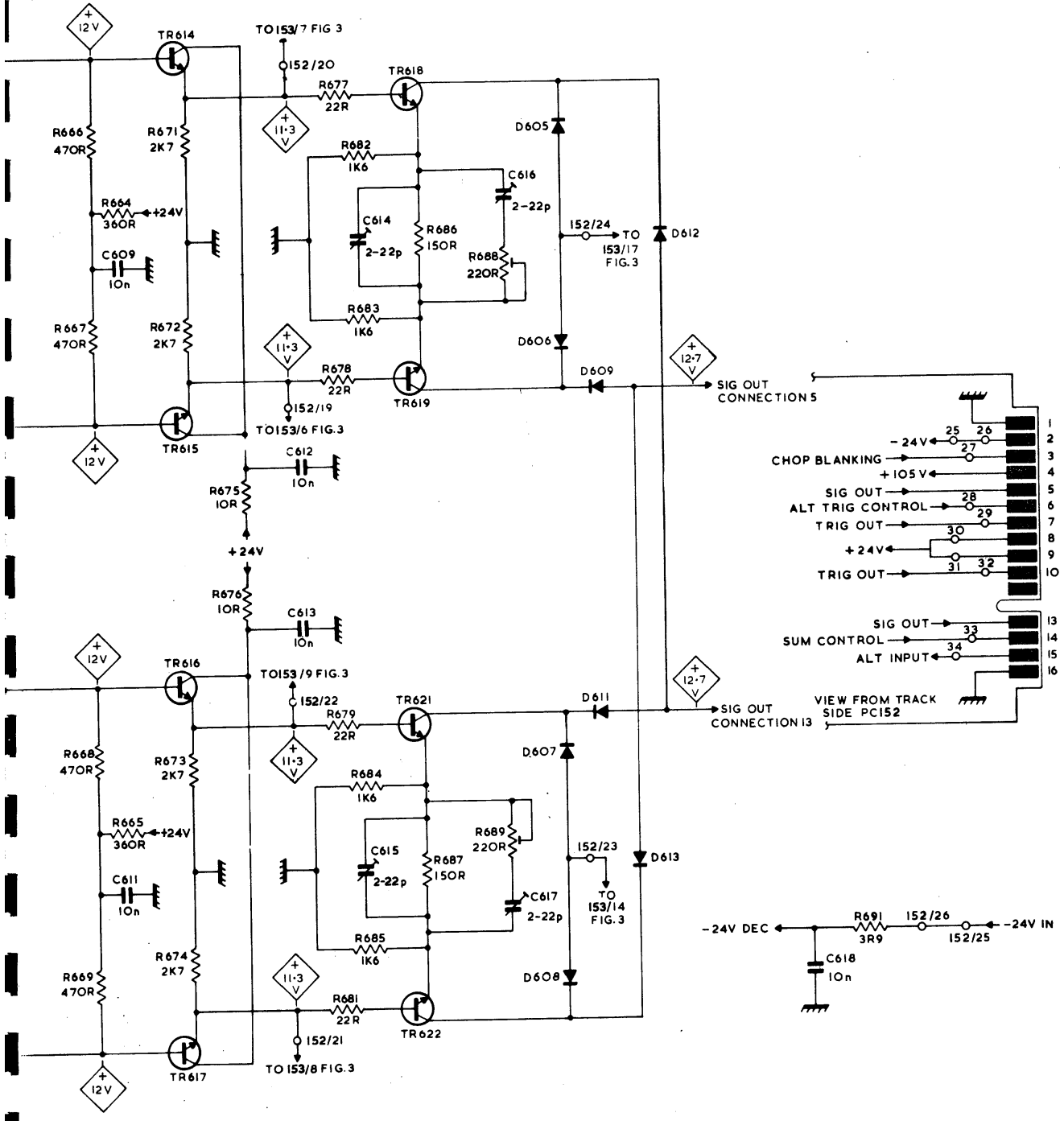

DUAL TRACE AMPLIFIER TYPE V4  
PC152 FIG.2

	793	794	799
	786	788	791
	787	789	792
	795	798	799
	762	763	763
	TR756	TR758	S753a
	TR757	TR759	S752b
	756	769	774
	761	763	773
	762	766	772
	759	767	774
	751	752	757
	753	754	756
	750	751	758
	TR751	S751a	S751b
	TR751	S751a	S751b
RESISTORS	751	753	755
	752	754	755
CAPACITORS	750	751	755
MISC.	TR751	S751a	S751b





RESISTORS	751	759	755	761	763	768	769	773	786	788	791	793	796
	752	754	756	762	764	766	771	772	787	789	792	794	797
CAPACITORS	750	751	755	757	758	759	765	767	762	763	764	765	766
MISC.	D751	TR751	S751a	S751b	S751c	S751d	S751e	TR752	TR753	D753	TR756	TR758	S752a
											TR757	TR759	S752b
											D754	D756	D758
											D755	D757	D759
											D761	D762	D762

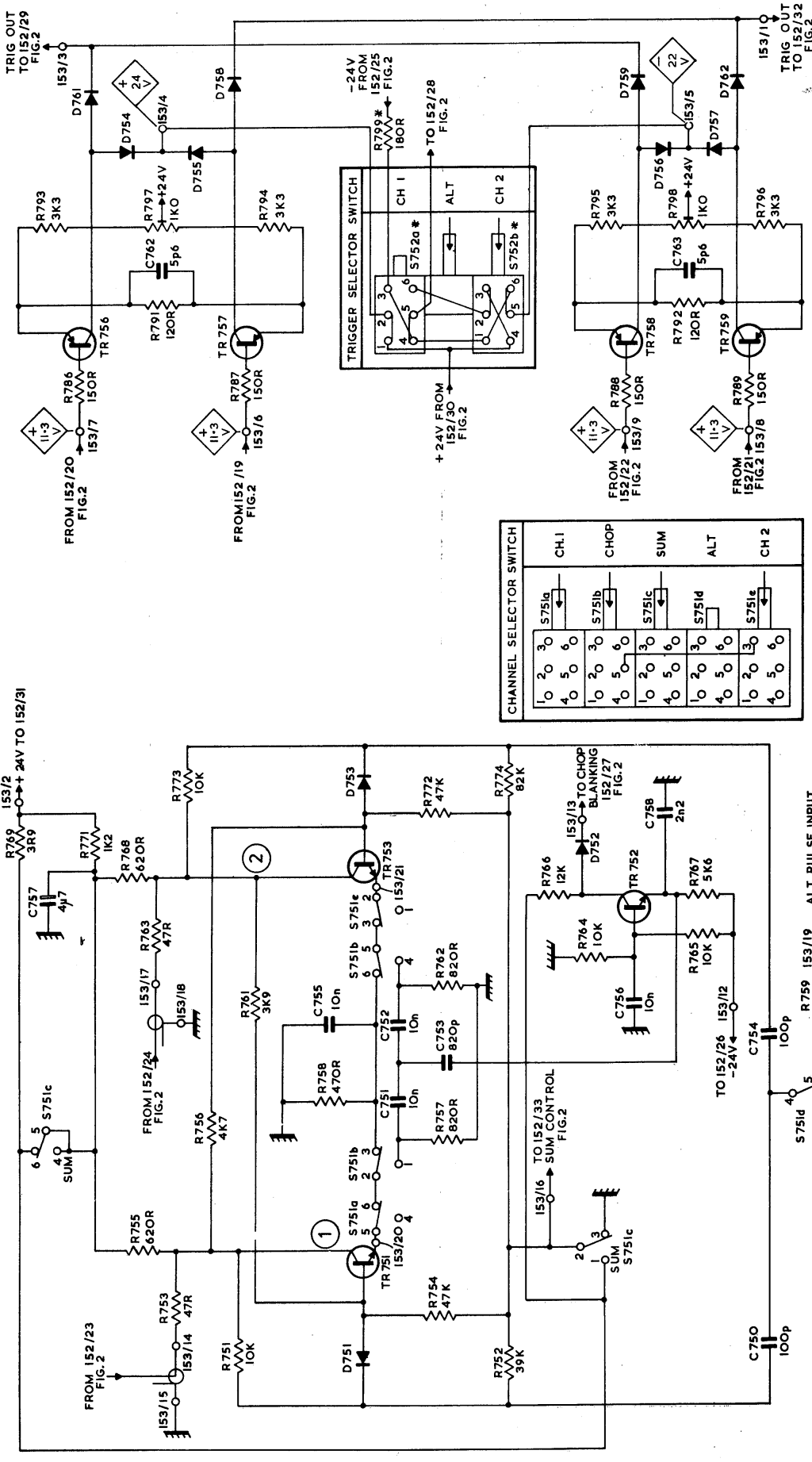

DUAL TRACE AMPLIFIER TYPE V4  
FIG. 3

NOTES.  
1. 153/3 DENOTES PC BOARD/EYELET OR TERMINAL No.  
2. \* DENOTES COMPONENTS NOT MOUNTED ON PC BOARD

A B C D E F G H

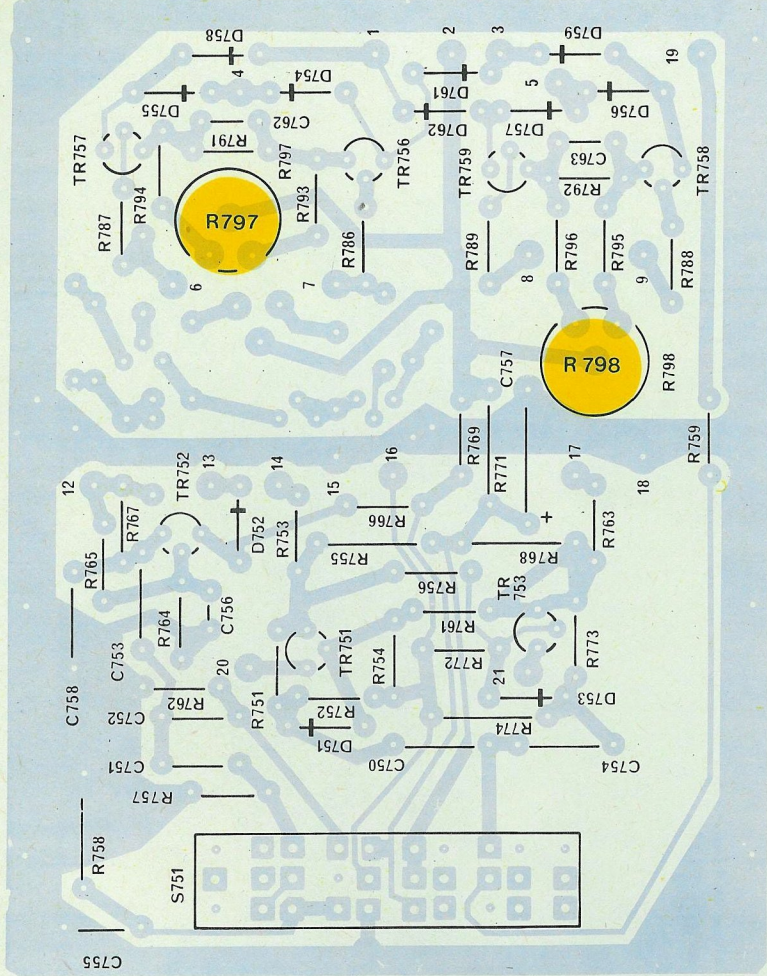

PC 153

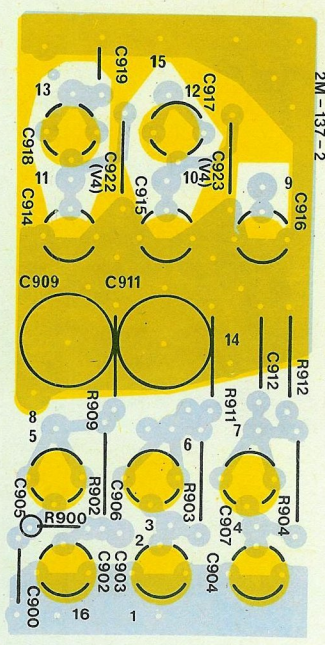

2M-137-2

PC 152

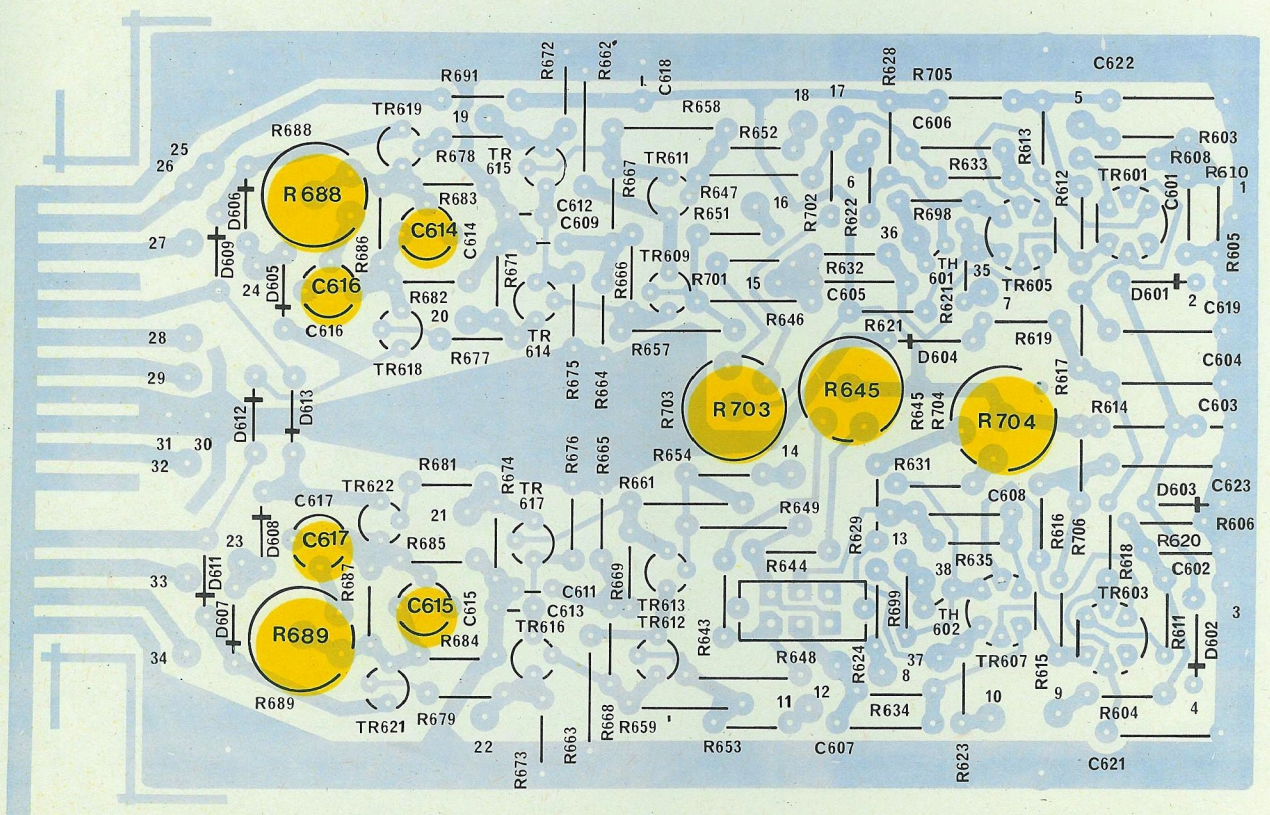

FIGURE 4 COMPONENT REFERENCE