

**TEKTRONIX®**

21 / 31

**CALCULATOR INTERFACE**

NOV 26 1973

( Preliminary )

**INSTRUCTION MANUAL**

Tektronix, Inc.  
P.O. Box 500  
Beaverton, Oregon 97005

973

**Copyright © 1973 by Tektronix, Inc., Beaverton, Oregon.  
Printed in the United States of America. All rights reserved.  
Contents of this publication may not be reproduced in any  
form without permission of Tektronix, Inc.**

**U.S.A. and foreign Tektronix products covered by U.S. and  
foreign patents and/or patents pending.**

**TEKTRONIX is a registered trademark of Tektronix, Inc.**

# TEK 21/31 Calculator Interface

## TABLE OF CONTENTS

Introduction	1
Input/Output	2
List of Signals	2
Connector and Cable Description	4
I/O Bus	5
Timing and Control	5
External Bus	8
DMA Channel	11
Test Overwrite	12
Data Bus	12
Remote Addressing	14
Specifications	18
Typical Interface Description	20



## INTRODUCTION

This manual provides a working guide for the service technician and peripheral interface designer. The technician should be able to isolate problems located either in the calculator or the peripheral. The designer should be able to use this manual in the design of interface devices which link the calculator to his particular peripheral.

The TEK 21 and TEK 31 calculators can interact with a variety of peripherals through a 50 pin connector and cable, which is referred to as the input/output (I/O) bus. The I/O bus comprises three classes of signals called the timing and control bus, the external (EXT) bus, and the data input/output (DIO) bus. These signals will be described in detail in this manual. The I/O bus is the link between the calculator and the peripherals. The Keyboard and printer use the EXT bus, while data is transferred to the display over the DIO bus.

Tektronix calculator peripherals are addressed by the REMOTE key, followed by a two digit address. Indirect addressing is possible by storing the Remote Address in a K register in the TEK 21 or in an R register in the TEK 31, and then pressing REMOTE followed by the Register and its Address.

The calculator may be linked to several peripherals, in parallel, as long as the total cable length does not exceed 100 feet and is terminated in an impedance load of 120 ohms.

A DMA channel in the TEK 31 can transmit data between the internal memory of the calculator and an external device. Program steps or data registers may be transferred through the DMA channel.

## INPUT/OUTPUT

## List of Signals

Following is a list of signal names and their mnemonic name along with their pin assignments for the calculator I/O bus.

The mnemonic name with a bar over the word (  $\overline{\quad}$  ) are TRUE or ASSERTED in the low or near ground state and all other signals are TRUE in the high state (near 3.5 V DC).

SIDE A	MNEMONIC NAME	SIGNAL NAME
1	GND	GROUND
2	$\overline{\text{STOP}}$	STOP
3	$\overline{\text{BUSY}}$	SYSTEM BUSY
4	$\overline{\text{DISP}}$	DISPLAY
5	$\overline{\text{ESYNC}}$	EXTERNAL SYNC
6	$\overline{\text{ECP2}}$	EXTERNAL CLOCK PHASE 2
7	$\overline{\text{ECP1}}$	EXTERNAL CLOCK PHASE 1
8	$\overline{\text{EXT 32}}$	EXTERNAL BUS BIT 32
9	$\overline{\text{CALL}}$	CALL
10	$\overline{\text{DCLOW}}$	DC LOW
11	$\overline{\text{ERST}}$	ERROR SET
12	$\overline{\text{EROT}}$	ERROR FLASH
13	+5 VOLTS	TERMINATING VOLTAGE
14	$\overline{\text{PRRT}}$	POWER RESET
15	$\overline{\text{EXT 128}}$	EXTERNAL BUS BIT 128
16	$\overline{\text{AVS}}$	ADDRESS VALID STROBE
17	$\overline{\text{DMAWR}}$	DIRECT MEMORY ACCESS WRITE TO CALCULATOR
18	$\overline{\text{DMARD}}$	DIRECT MEMORY ACCESS READ FROM CALCULATOR
19	$\overline{\text{FXTD}}$	FIXED POINT DATA
20	UD1	UNIT DIGIT ADDRESS BIT 1
21	TD1	TENS DIGIT ADDRESS BIT 1
22	$\overline{\text{DW}}$	DATA WORD
23	TD4	TENS DIGIT ADDRESS BIT 4
24	TD8	TENS DIGIT ADDRESS BIT 8
25	GND	GROUND

TEK 21/31 Calculator Interface - Input/Output

List of Signals (cont.)

SIDE B	MNEMONIC NAME	SIGNAL NAME
1	GND	GROUND
2	<u>D104</u>	DATA INPUT OUTPUT BIT 4
3	<u>D108</u>	DATA INPUT OUTPUT BIT 8
4	<u>D102</u>	DATA INPUT OUTPUT BIT 2
5	<u>D101</u>	DATA INPUT OUTPUT BIT 1
6	<u>EXT16</u>	EXTERNAL BUS BIT 16
7	<u>INHOUT</u>	INHIBIT OUT
8	<u>STBE</u>	STROBE
9	<u>EXT8</u>	EXTERNAL BUS BIT 8
10	<u>EXT4</u>	EXTERNAL BUS BIT 4
11	<u>EXT64</u>	EXTERNAL BUS BIT 64
12	<u>CRCV</u>	CALCULATOR RECEIVE
13	+5 VOLTS	TERMINATING VOLTAGE
14	<u>EXT1</u>	EXTERNAL BUS BIT 1
15	<u>EXT2</u>	EXTERNAL BUS BIT 2
16	<u>EXTPTR</u>	EXTERNAL PRINTER PRESENT
17	<u>FLTP</u>	FLOATING POINT DATA
18	<u>AC</u>	ADDRESS COMPARE
19	<u>IHIN</u>	INHIBIT IN
20	<u>DMARY</u>	DIRECT MEMORY ACCESS READY
21	UD2	UNITS DIGIT BIT 2
22	TD2	TENS DIGIT BIT 2
23	UD8	UNITS DIGIT BIT 8
24	UD4	UNITS DIGIT BIT 4
25	GND	GROUND

Connector and Cable Description

A variety of cables is available for use with calculators, as shown in the following listing. One of these cables, as selected by the purchaser, is supplied with each calculator peripheral obtained from Tektronix. (Cable lengths have not been fully determined at this writing.)

	Type 1	Type 2
Short Cable	012-0498-00	012-1499-00
Long Cable	012-0498-01	012-0499-01

Type 1 has a 90° connector at one end of the cable and a T connector at the other end of the cable.

Type 2 has a 90° connector at each end of the cable.

The following diagram shows the pin locator for each of the 50 signals which are named on the "List of Signals" pages.

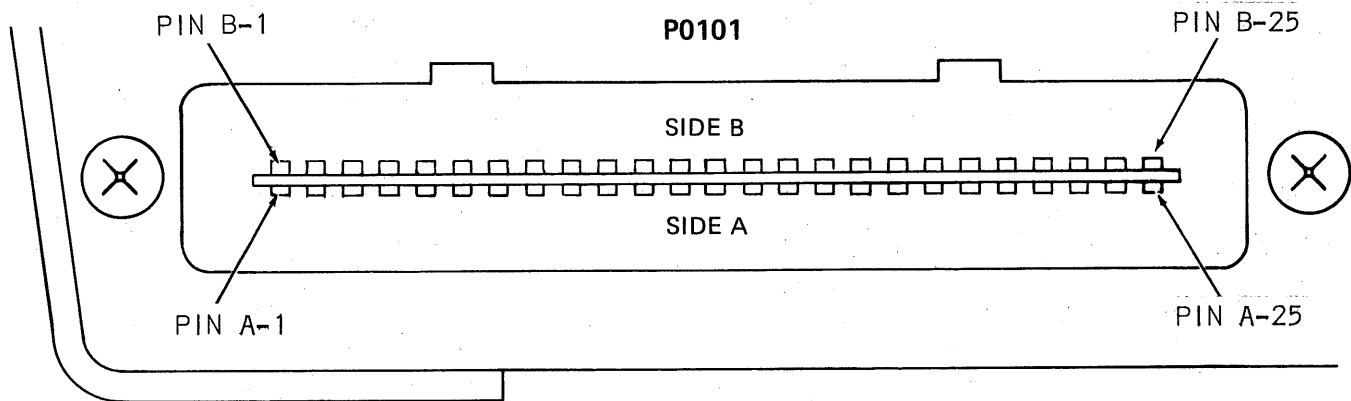

Figure 1



## I/O BUS

## Timing and Control

The calculator operates internally on a two phase non-overlapping clock. Three signals  $\overline{ESYNC}$ ,  $\overline{ECP1}$ , and  $\overline{ECP2}$  are provided so that an external device may synchronize its operations to the calculator.  $\overline{ECP1}$  and  $\overline{ECP2}$  are time interval signals that are generated in the calculator.  $\overline{ESYNC}$  is a calculator generated pulse, and is used as the standard time reference for the system.  $\overline{ESYNC}$  is defined as the time interval from the leading edge of  $\overline{ECP1}$  which occurs during T24 to the next leading edge of  $\overline{ECP1}$  which occurs during T0. This is a time interval of 2 microseconds. Figure 2 shows the timing relationship between  $\overline{ECP1}$ ,  $\overline{ECP2}$ , and  $\overline{ESYNC}$ .

An  $\overline{ESYNC}$  pulse is transmitted every calculator word. A calculator word is defined as 25 T times, or from T0 thru T24. See Fig 3. Each T time is defined as the interval from the leading edge of  $\overline{ECP2}$  to the next leading edge of  $\overline{ECP2}$ , therefore,  $\overline{ESYNC}$  is sent every 25 T times. All calculator timing signals are referenced to a 5 MHz crystal oscillator.

A signal called  $\overline{DCLOW}$  is provided by the power supply.  $\overline{DCLOW}$  is asserted (is made to be true) whenever the logic supply is not within specifications. The signal can be used to initialize all logic at turn on.  $\overline{DCLOW}$  can be found on pin A10 of the I/O Connector.

A programmable reset signal called  $\overline{PRRT}$  is found on pin A14. This signal is generated whenever  $\overline{DCLOW}$  is found to be true or whenever the CLEAR key has been depressed.

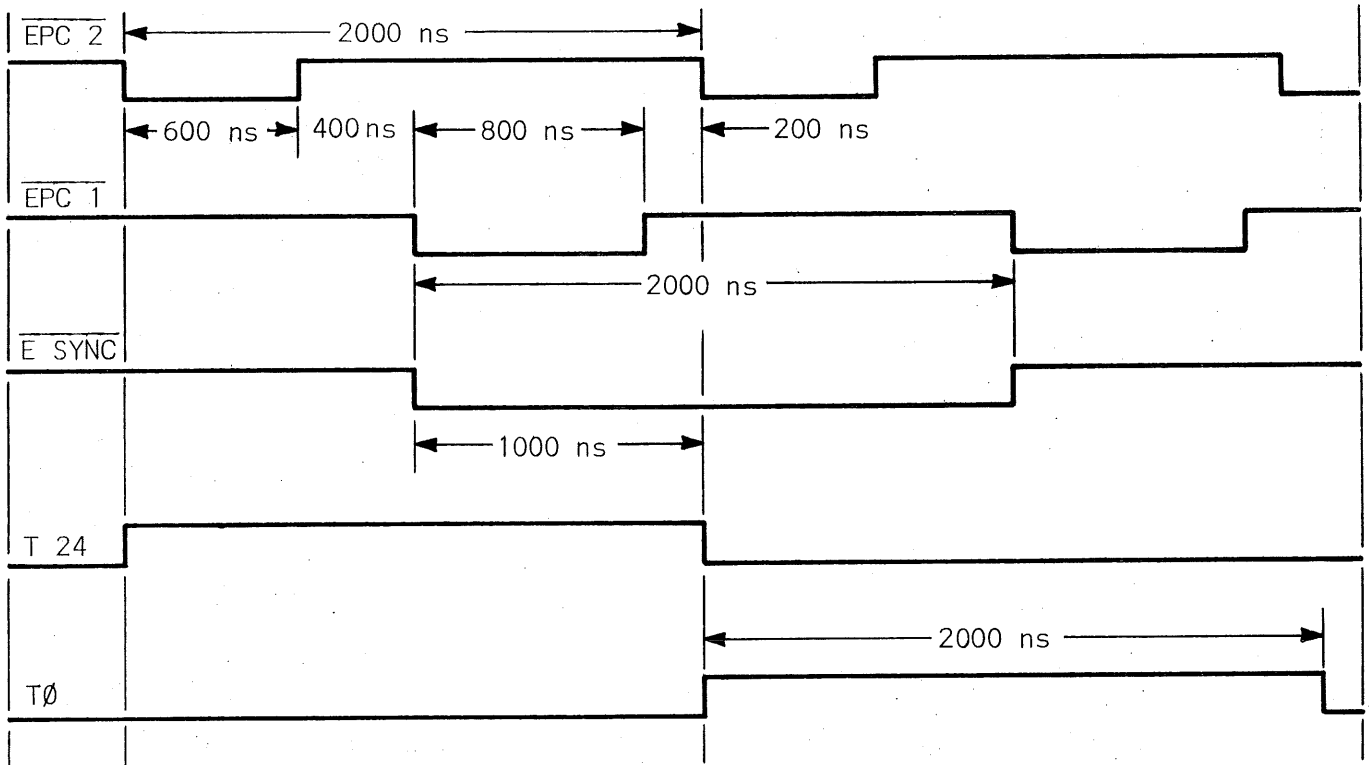

Figure 2

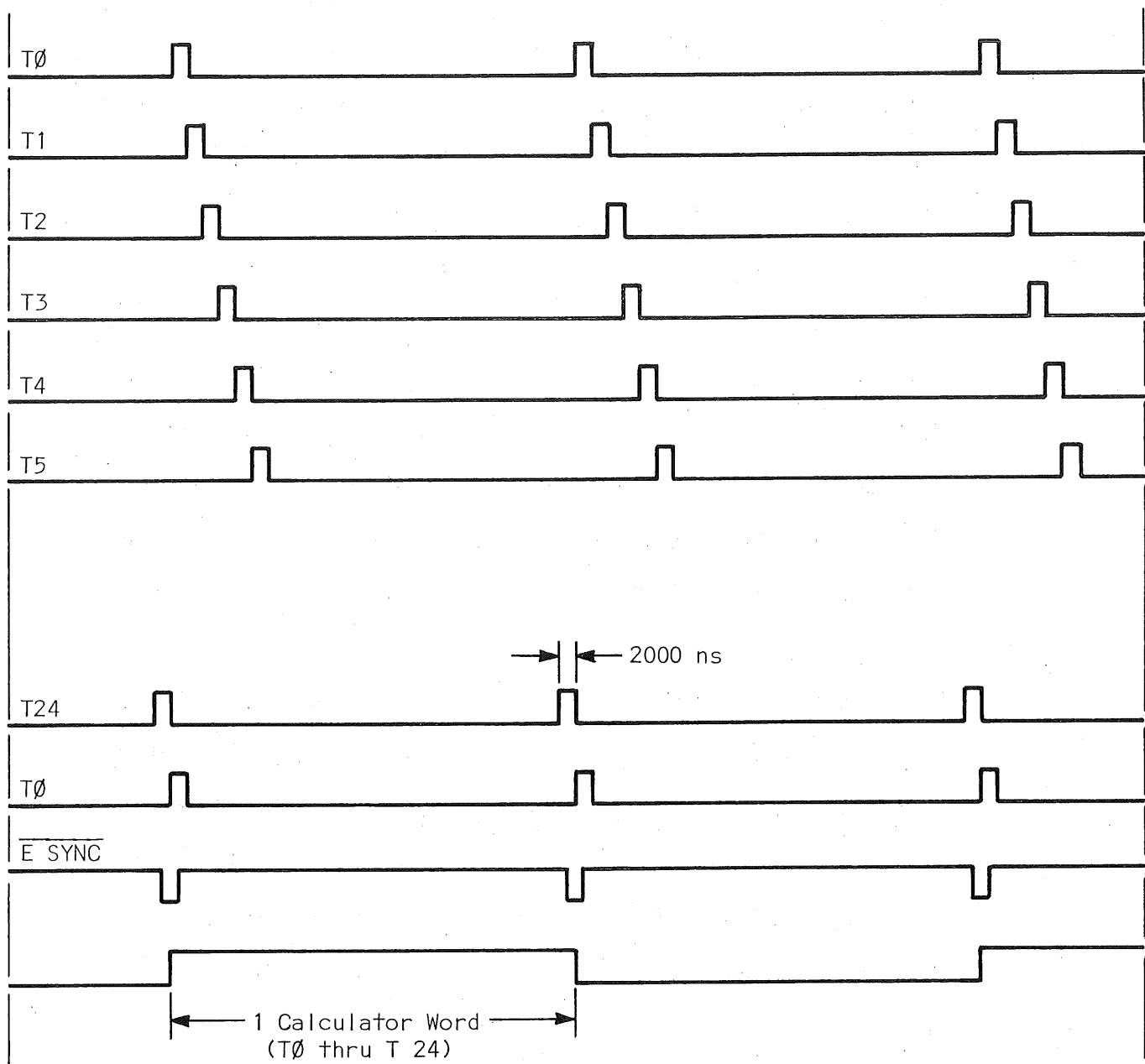

Figure 3

## Tek 21/31 Calculator Interface - I/O Bus

### Timing and Control (cont)

A calculator  $\overline{\text{BUSY}}$  signal indicates that some portion of the system is busy. The signal may include any portion of the system from the calculator to one of the peripherals. The busy signal causes the  $\overline{\text{BUSY}}$  indicator in the calculator display to be lit.  $\overline{\text{BUSY}}$  is found on pin A3 of the I/O connector.

A  $\overline{\text{STOP}}$  signal, pin A2, is provided so that a program that is in progress may be stopped by holding down the  $\overline{\text{STOP}}$  line or the  $\overline{\text{STOP}}$  key until the calculator goes out of the  $\overline{\text{BUSY}}$  mode. The  $\overline{\text{STOP}}$  condition is non-destructive, which means that the calculator will complete execution of the present instruction, and that depression of the CONTINUE key will cause the program to continue execution at the point where it terminated.

The  $\overline{\text{ERST}}$  and  $\overline{\text{EROT}}$  signals are used to set and indicate the flashing of the display. If  $\overline{\text{EROT}}$  is true, the display is flashing. This condition can only be reset by the CLEAR key on the calculator. Asserting  $\overline{\text{ERST}}$  for at least one T-time will cause the display to enter a flashing mode. A flashing display may also be caused by an overrange condition such as division by zero.

### External Bus

The external bus is an eight bit wide bus which is used primarily to transfer keycodes or alphanumerics to or from an external device. In the TEK 31, the EXT bus is also used to transfer data to or from an external device under control of the Direct Memory Access (DMA) channel.

## TEK 21/31 Calculator Interface - I/O BUS

### External Bus (cont.)

For bus management, Inhibit Input ( $\overline{IHIN}$ ) and Inhibit Output ( $\overline{INHOUT}$ ) are provided.  $\overline{IHIN}$  is asserted to indicate that all devices on the bus (except the one generating the signal) are to inhibit receiving the external bus.  $\overline{IHIN}$  is asserted while in the LEARN mode and forces all keycodes to be "captured" by the automatic sequencer and are non-executing. In addition,  $\overline{IHIN}$  is asserted when using the DMA channel, so that data may be transferred directly to the calculator's memory without being executed. In the TEK 31,  $\overline{IHIN}$  is asserted while in the IDLE mode until a key is depressed. The calculator may then release  $\overline{IHIN}$  and reissue the keycode.

$\overline{INHOUT}$  is asserted whenever the programmer is in the RUN mode and forces all other devices to inhibit driving the external bus. This signal is also used to inhibit extraneous keyboard entries from affecting the program in progress.  $\overline{INHOUT}$  turns on the BUSY indicator on the calculator display and also inhibits the keyboard.

The external bus comprises eight bidirectional lines,  $\overline{EXT1}$  to  $\overline{EXT128}$ . ( $\overline{EXT1}$ ,  $\overline{EXT2}$ ,  $\overline{EXT4}$ , ...,  $\overline{EXT128}$ ). Seven of the bits ( $\overline{EXT1}$  to  $\overline{EXT64}$ ) carry keycodes during program execution. The eighth signal ( $\overline{EXT128}$ ) is asserted whenever the HOLD FOR ALPHA key is depressed and another key is stuck. This signal indicates that the data is alphanumeric and not an operational code. With HOLD FOR ALPHA key depressed, an alpha character will be printed, if a printer is connected to the system. All keycodes are ASCII.

## TEK 21/31 Calculator Interface - I/O BUS

### External Bus (cont.)

Valid data is indicated by the assertion of the signal, external strobe ( $\overline{STBE}$ ). If the system is not  $\overline{BUSY}$  and  $\overline{INHOUT}$  is not asserted, any device may use the external bus to transmit data. Data must be placed on the bus at least one T time ( $2 \mu s$ ) prior to  $\overline{STBE}$  and must last one T time after  $\overline{STBE}$ .  $\overline{STBE}$  must be at least one T time wide.

A signal on the I/O connectors, used exclusively by the TEK 31, is called EXTERNAL PRINTER (EXTPTR). If this signal is asserted by an external printer, the calculator will send the display as a formatted ASCII 16 character string with EXT128 set whenever the PRINT DISPLAY key is depressed. The characters may be sequenced by the external printer by asserting  $\overline{BUSY}$ . The TEK 31 will check  $\overline{BUSY}$  and wait for it to terminate before sending the next character in the string.

Another signal used exclusively by the TEK 31 is the CALL line. This signal is used to initiate a subroutine call in the TEK 31. If  $\overline{CALL}$  is asserted with one of the eight EXT signals ( $\overline{EXT1}$ ,  $\overline{EXT2}$ , ...,  $\overline{EXT128}$ ) and  $\overline{STBE}$  and provided the keycode on the external bus is in the range from 101 to 130 (in octal), the TEK 31 programmer will perform the command EXC X, with X equal to the keycode. This is the same as having a user definable overlay in place on the calculator keyboard and pressing one of the user definable keys whose octal codes are from 101 to 130

## TEK 21/31 Calculator Interface - I/O BUS

External Bus (cont.)

DMA Channel. The TEK 31 calculator has a Direct Memory Access (DMA) channel for transferring data between the internal memory of the calculator and an external device. The address of the DMA transfer is set by the ADDRESS key on the calculator and follows the same rules as a tape transfer. The length of the transfer is controlled by the external device, and must either be fixed or else transmitted to the DMA device by a REMOTE sequence. The DMA device determines how many locations are to be transferred.

During a writing to calculator process, the DMA transfer is initiated by asserting  $\overline{\text{BUSY}}$  and DMA WRITE ( $\overline{\text{DMAWR}}$ ). The calculator responds with DMA READY ( $\overline{\text{DMARY}}$ ) and INHIBIT IN ( $\overline{\text{IHIN}}$ ). At this time, the DMA device may place data on the External bus and issue the EXT bus strobe ( $\overline{\text{STBE}}$ ). This can be repeated at any rate up to a maximum rate of one strobe every 8 microseconds. (See previous reference to timing of  $\overline{\text{STBE}}$ .)

If a read from calculator operation was requested, DMA READ ( $\overline{\text{DMARD}}$ ) would be asserted instead of  $\overline{\text{DMAWR}}$ . The calculator will respond with  $\overline{\text{DMARY}}$ ,  $\overline{\text{IHIN}}$  and the first byte of data on the external bus. When the DMA device issues  $\overline{\text{STBE}}$ , it is reading data from the External bus. The calculator will respond by locating the next byte and placing it on the External bus so that the next byte may be read. Again  $\overline{\text{STBE}}$  may be issued at any rate up to a maximum rate of one strobe every 8 microseconds.

Program steps and registers may both be transferred through the DMA channel. If program steps are transferred, each byte

## TEK 21/31 Calculator Interface - I/O BUS

### External Bus (cont.)

corresponds to one keycode. If registers are being transferred, each 8-bytes corresponds to one register. If registers are being transferred from the calculator, an extra initialization  $\overline{\text{STBE}}$  must be issued by the DMA device prior to starting the transfer.

Test Overwrite. Test Overwrite is a hardware feature of the TEK 31 designed to make software operating systems easier to use. This feature applies to both a magnetic tape operating system (TOS) and a disk operating system (DOS). The disk is a bulk storage device external to the TEK 31.

When information is transferred from the internal magnetic tape or from an external storage device (via the DMA channel) into the internal calculator memory, the calculator performs a test at the end of the transfer to determine if the page containing the last executed instruction has been written into. If it has, the TEK 31 executes an unconditional branch to step 0000.

### Data Bus

The DATA input/output (DIO) bus comprises 19 signal lines. This bus is used to input or output data under program control via the REMOTE key sequence. Data is transferred between the data register in the calculator and the peripheral.

When the system is idle ( $\overline{\text{BUSY}}$  not asserted), data is present on four bidirectional lines termed DI01, DI02, DI04, and DI08. Data is valid on these lines from T0 through T15. It takes 16 T-times to transmit the data from the Calculator display register. Data is formatted in the following manner:



## TEK 21/31 Calculator Interface - I/O BUS

### Data Bus (cont.)

#### T0 - Status Bits

DI01 = 0 (High) = POSITIVE EXPONENT

DI01 = 1 (Low) = NEGATIVE EXPONENT

DI02 = 0 (High) = ORDINARY NOTATION

DI02 = 1 (Low) = SCIENTIFIC NOTATION

DI04 = 0 (High) = POSITIVE MANTISSA

DI04 = 1 (Low) = NEGATIVE MANTISSA

DI08 = 0 (High) = DECIMAL POINT NOT DISPLAYED

DI08 = 1 (Low) = DECIMAL POINT DISPLAYED

T1 - Defines the decimal point location of the display, from 0 through 10. Position zero is the right-most position of the display. Position 10 is the left most position of the display.

T2 - Least Significant Digit (LSD) of exponent on Binary Coded Decimal format (BCD).

T3 - Most Significant Digit (MSD) of exponent in BCD.

T4 - LSD of mantissa in BCD (not displayed).

T5 - 2nd LSD of mantissa in BCD (not displayed).

T6 - LSD of display in BCD.

T7 through T14 are BCD digits of display.

T15 - MSD of mantissa in BCD.

Formatted data, such as error messages, can be sent directly to the display by asserting the DISP line and entering one digit

## TEK 21/31 Calculator Interface - I/O BUS

Data Bus (cont.)

at a time from  $T_0$  through  $T_{15}$ . In addition to the above codes, any digit that is equal to binary "15" ( $DI_{01} = DI_{02} = DI_{04} = DI_{08} = 1$ ) will be blanked by the display.  $\overline{DISP}$  must be asserted before  $T_0$  and held until after  $T_{15}$ . If the peripheral is asserting  $\overline{BUSY}$ , it must release  $\overline{BUSY}$  before releasing  $\overline{DISP}$ . This is to prevent the calculator from overwriting the data since the display will update on the trailing edge of  $\overline{BUSY}$  unless  $\overline{DISP}$  is asserted.

Remote Addressing. Data may also be sent to or from the calculator by use of the REMOTE key. The REMOTE ADDRESS is defined as the two digits following the REMOTE key in direct addressing, or the two least significant digits of the display in indirect addressing.

Once the remote address has been established, it is placed on the UNIT DIGITS ( $UD_1 - UD_8$ ) and TENS DIGITS ( $TD_1 - TD_8$ ) address lines. A short time later the calculator asserts ADDRESS VALID STROBE ( $\overline{AVS}$ ). This signal lasts from  $T_{10}$  through  $T_{15}$  and indicates that an external device should decode the UNITS and TENS digits address line to see if it is the addressed device. See Figure 4. If a device recognizes its own address it must signify that it is present by asserting ADDRESS COMPARE ( $\overline{AC}$ ). If the device does not assert  $\overline{AC}$  during  $\overline{AVS}$ , it will be assumed it is not present and no data will be transferred.

There are two forms of data that may be transferred from the calculator under REMOTE control, namely fixed point (scientific notation) and floating point. As an example, suppose the following keys were struck in sequence:

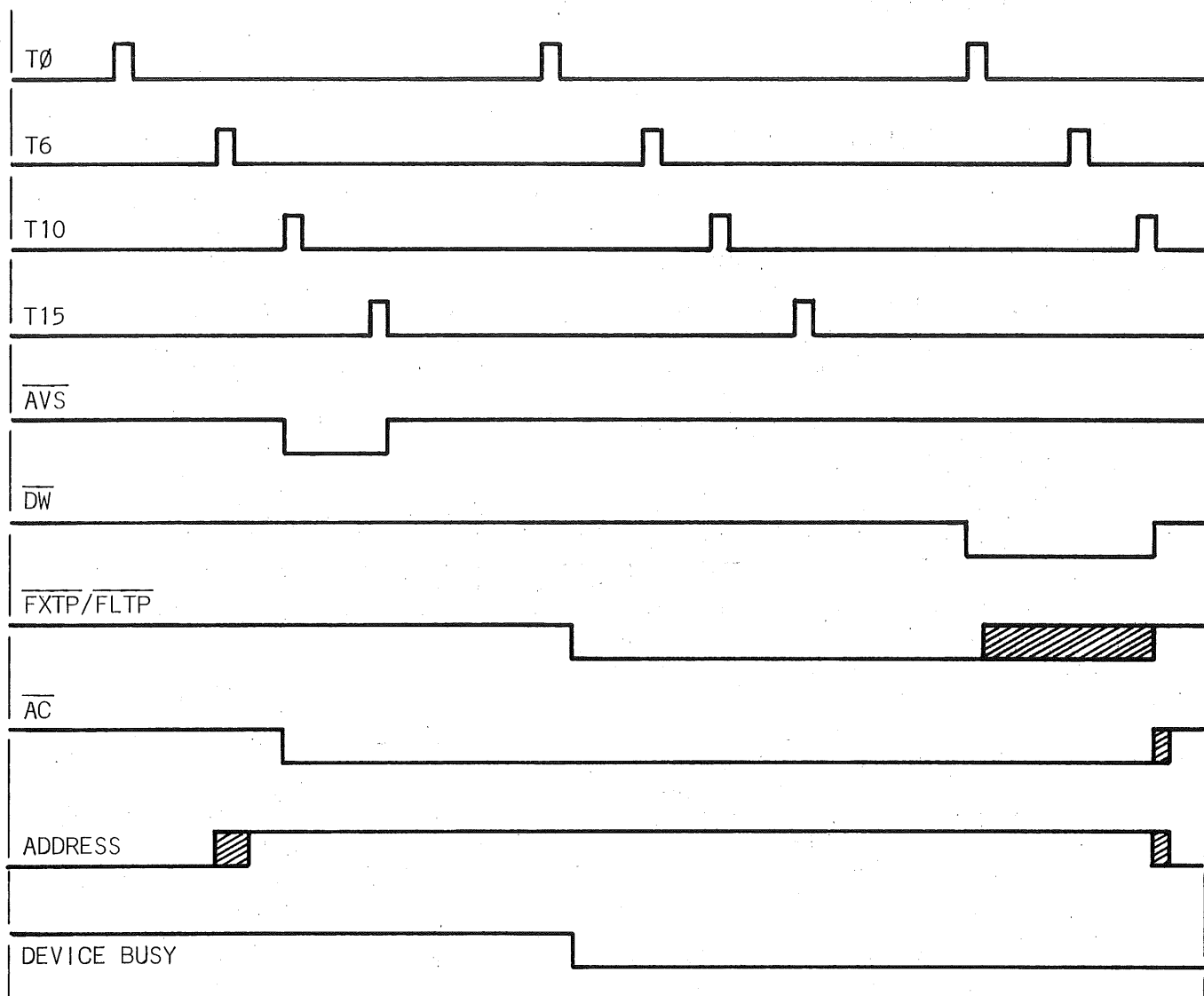

Figure 4

TEK 21/31 Calculator Interface - I/O Bus

Data Bus (cont.)

CLEAR 1 2 3 = RMT 55

Note: the use of the = sign or a ) is necessary to normalize the data in the display register. Device 55 could now have a choice of receiving data in two different forms. One of these would be in scientific notation (fixed point), See figure 5, and the other would be in floating point (see figure 6). In figure 5, the decimal point will appear between the 1 and the 2.

T15	T14	T13	T12	T11	T10	T9	T8	T7	T6		T3	T2
1	2	3	0	0	0	0	0	0	0	+	0	2

Scientific  
Figure 5

T15	T14	T13	T12	T11	T10	T9	T8	T7	T6		T3	T2
0	0	0	0	0	0	0	1	2	3			

Floating Point  
Figure 6

The choice as to whether a device requires the data in fixed point or floating point must be made by the interface. It is a question as to whether one must keep trace of an exponent (fixed point) or decimal point and exponent (floating point).

If data is contained in the display register in floating point notation, it can be transferred in either floating point if  $\overline{\text{FLTP}}$  is asserted, or in scientific notation if  $\overline{\text{FXTTP}}$  is asserted. If data is contained in the display register in scientific notation, it can only be transferred in scientific notation, regardless of whether  $\overline{\text{FLTP}}$  or  $\overline{\text{FXTTP}}$  is asserted.

If the floating point range of the display register is exceeded,

Data Bus (cont.)

the contents will automatically shift to scientific notation, and can then only be transferred in scientific notation as previously explained. If an operation is done which causes a number in floating point notation to go into scientific notation, followed by an operation which causes the number to come within the floating point range of the display register, the number will return to floating point. Pressing DEG/RAD twice will change a number in scientific notation to floating point notation, provided the number is within the floating point range of the display register.

Once a device recognizes its address and asserts ADDRESS COMPARE ( $\overline{AC}$ ), it may indicate the form of data it requires. It does this by asserting either FIXED POINT ( $\overline{FXTP}$ ) or FLOATING POINT ( $\overline{FLTP}$ ) simultaneously with  $\overline{AC}$ . If the remote device is busy on a prior task, it may indicate it is busy when it recognizes its address by asserting  $\overline{AC}$  and neither  $\overline{FXTP}$  or  $\overline{FLTP}$ . The calculator will then recognize that the addressed device is present and stays busy until either  $\overline{FXTP}$  or  $\overline{FLTP}$  is asserted.

Once a data request has been made, the calculator responds with a signal called DATA WORD ( $\overline{DW}$ ). DATA WORD is asserted from T0 through T15 and indicates the presence of valid data on the D10 lines. If the requested data is in floating point,  $\overline{DW}$  lasts for one and only one calculator word. At the end of  $\overline{DW}$ , the remote address is reset and the remote device must release  $\overline{AC}$  and  $\overline{FLTP}$ . If the request data is in fixed point form,  $\overline{DW}$  will last for as many calculator words as necessary. The remote device indicates that it desires no additional data by releasing  $\overline{FXTP}$  during  $\overline{DW}$ .

## SPECIFICATIONS

All of the 44 signals that are used for interfacing with the TEK 21/31 calculator shall have the following electrical specifications:

High state voltage  $\geq 2.4$  volts

Low state voltage  $\leq 0.8$  volts

All drivers for these signal lines will be SN7438N or their equivalent and have the following characteristics:

High level output leakage current  $\leq 250$  ua

Low level output voltage  $\leq 0.4$  Volts @ 48mA  
sink current

Turn on Delay  $\leq 18$  ns

Turn off Delay  $\leq 22$  ns

All receivers on the I/O Bus will be National Semiconductor Unified Bus Receivers or their equivalent. These devices are designed for use in bus organized data transmission systems. They provide high noise immunity (2V typical) and built-in input hysteresis (1V typical). In addition, these devices do not draw current from the bus if they have no power applied. There are currently two such receivers in common usage:

DM8836 Quad Inverting Receiver

DM8837 Hex Receiver

Their electrical specifications are as follows:

Input current (input high)  $\leq 50$  uA

Turn on Delay  $\leq 30$  ns

Turn off Delay  $\leq 30$  ns

All I/O signal lines are to be considered transmission lines which are terminated at both ends. One end of the bus is terminated within the calculator. Once a peripheral is attached to

## TEK 21/31 Calculator Interface - Specifications

the I/O Bus, the bus must be terminated at the far end. Additional devices may share the same bus but the devices must be connected in parallel with the last device terminating the bus. A standard bus terminator consists of two diodes in series from pins A13, B13 (+5 volts) connected to one end of all terminating resistors. All terminating resistors are 120 OHM 5%. It is recommended that the I/O Bus be terminated using the Tektronix supplied Terminating Resistor Pack, Part No. 016-0567-00.

## TYPICAL INTERFACE DESCRIPTION

Figure 6 presents a typical interface circuit for a remote device that requires data in floating point.

U1 and U2 are bus receivers for the calculator I/O Bus. The TD and UD lines are received and then inverted and fed to the inputs of U5 and U6, BCD decoder. Notice that the outputs of U5 indicate which function is to be performed. Address VALID STROBE (AVS) will clock the flip-flop U7A into the true or set state if the selected output of U6 is low. This allows the Tens Digit of the address to be strapped by the user.

When U7A is set, it will assert the ADDRESS COMPARE ( $\overline{AC}$ ) line, through U9A, indicating that the addressed peripheral is present. If the peripheral is not holding  $\overline{BZY}$  in the low state, FLOATING POINT ( $\overline{FLTP}$ ) will be asserted. The calculator will respond with DATA WORD ( $\overline{DW}$ ) indicating that data is valid on the DIO lines. DW is ANDed with the output of U4C, Unit, which forms UNIT WORD. UNIT WORD will insure that the device does not respond to DATA WORD unless it is the addressed device.

Once the calculator asserts DW from T0 through T15, the TD and UD signal lines will be reset to all high. This is an invalid input to the BCD decoders so that U4 output will fall and reset flip-flop U7A. Once U7A is reset, U9 will cease driving the  $\overline{AC}$  and  $\overline{FLTP}$  signal lines.

Figure 8 is a schematic of a device that requires data in fixed point. Notice that much of the schematic is the same as Fig. 7. U7B, U9C, U10A and U8B were added to provide the capability of working in fixed point and as an input or output device.



# TEK 21/31 Calculator Interface

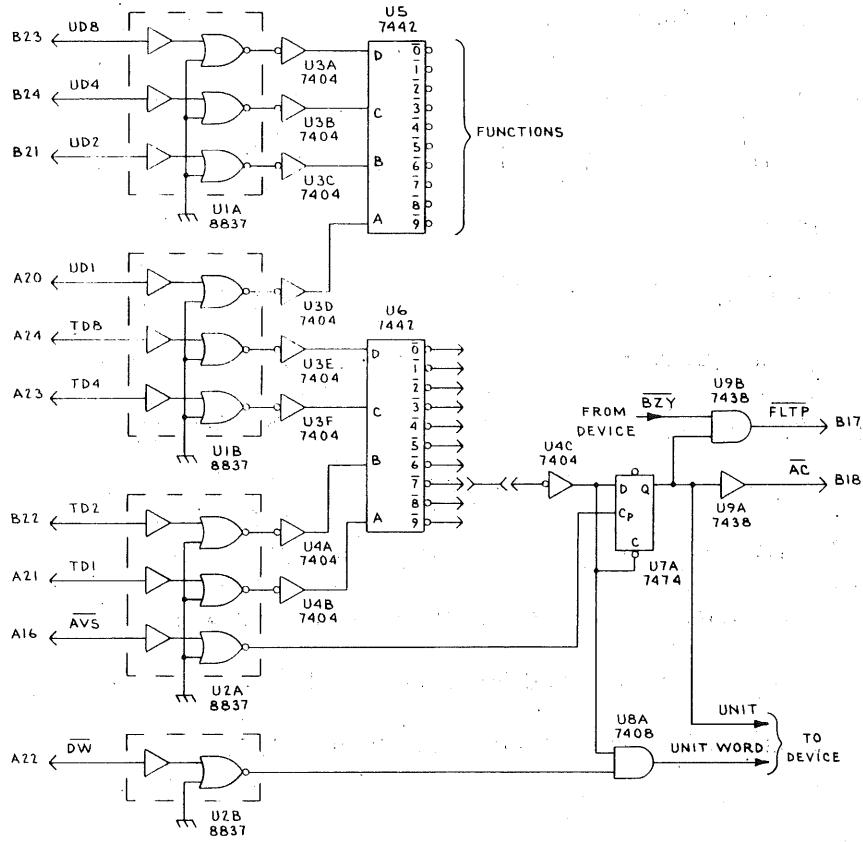

Fig 7

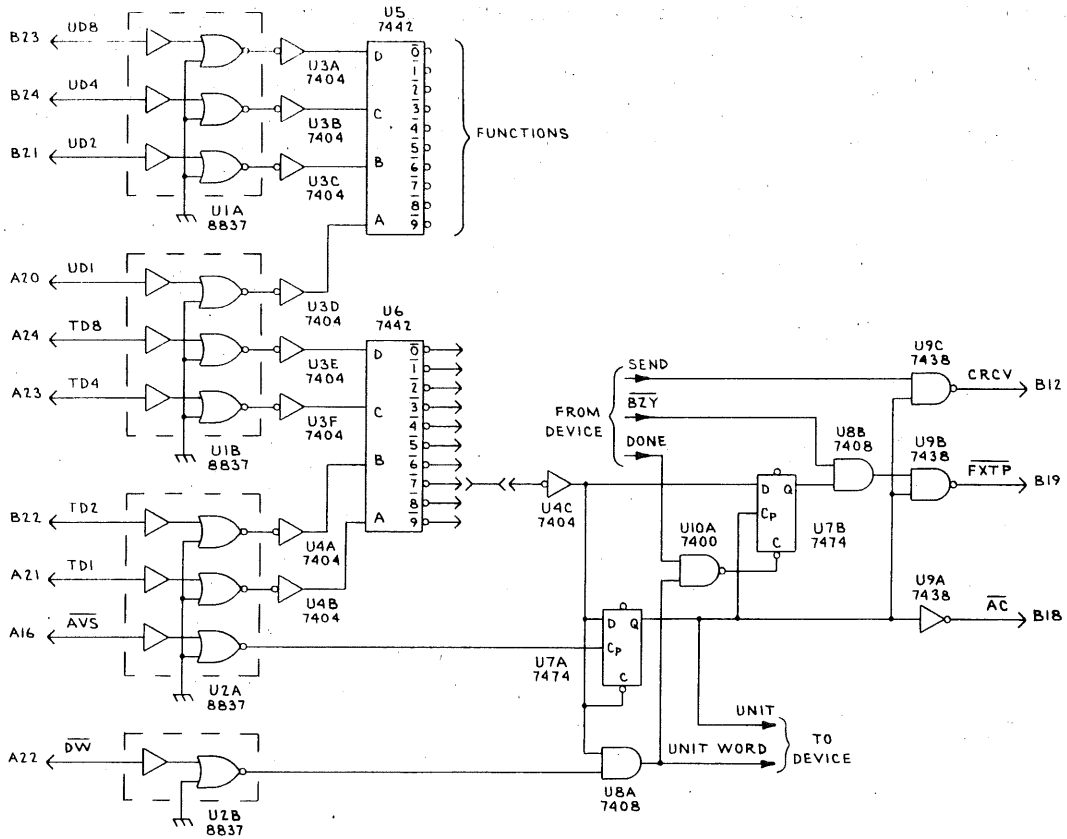

Fig 8

## TEK 21/31 Calculator Interface - Typical Interface Description

The operation of the circuit is the same as for the floating point mode up to the point where  $\overline{AC}$  is asserted. When flip-flop U7 went true it clocked flip-flop U7B true. If the peripheral is not busy ( $\overline{CBZY} = 1$ ) then  $\overline{FXTP}$  will be asserted. After  $\overline{FXTP}$  is asserted the calculator will issue  $\overline{DW}$ .  $\overline{DW}$  will last from  $T_0$  through  $T_{15}$  and repeat again at the next  $T_0$ . When the peripheral determines that this is the last DATA WORD it requires, it issues DONE. This will reset U7B, causing  $\overline{FXTP}$  to be released. At the end of the DATA WORD in progress, the calculator will sense that  $\overline{FXTP}$  has been released and will reset the remote address (UD and TD lines). The interface will detect this and reset U7A.

If this peripheral were an input device for the calculator, SEND would be high and CALCULATOR RECEIVE ( $\overline{CRCV}$ ) would be asserted along with  $\overline{AC}$ . DATA VALID in this case would indicate when the peripheral could drive the DIO lines to input data.