

# Instruction Manual

*Original*

Copyright © 1971 by Tektronix, Inc., Beaverton, Oregon. Printed in the United States of America. All rights reserved. Contents of this publication may not be reproduced in any form without permission of the copyright owner.

U.S.A. and foreign Tektronix products covered by U.S. and foreign patents and/or patents pending.



## **TYPE 576**

**INTEGRATED CIRCUIT  
ADAPTER**

**013-0124-00**

**ARCHIVE COPY**

**DO NOT REMOVE FROM FILES  
WITHOUT PERMISSION**

**RETURN TO MANUALS PRODUCTION  
GRAPHICS BLDG (76)**

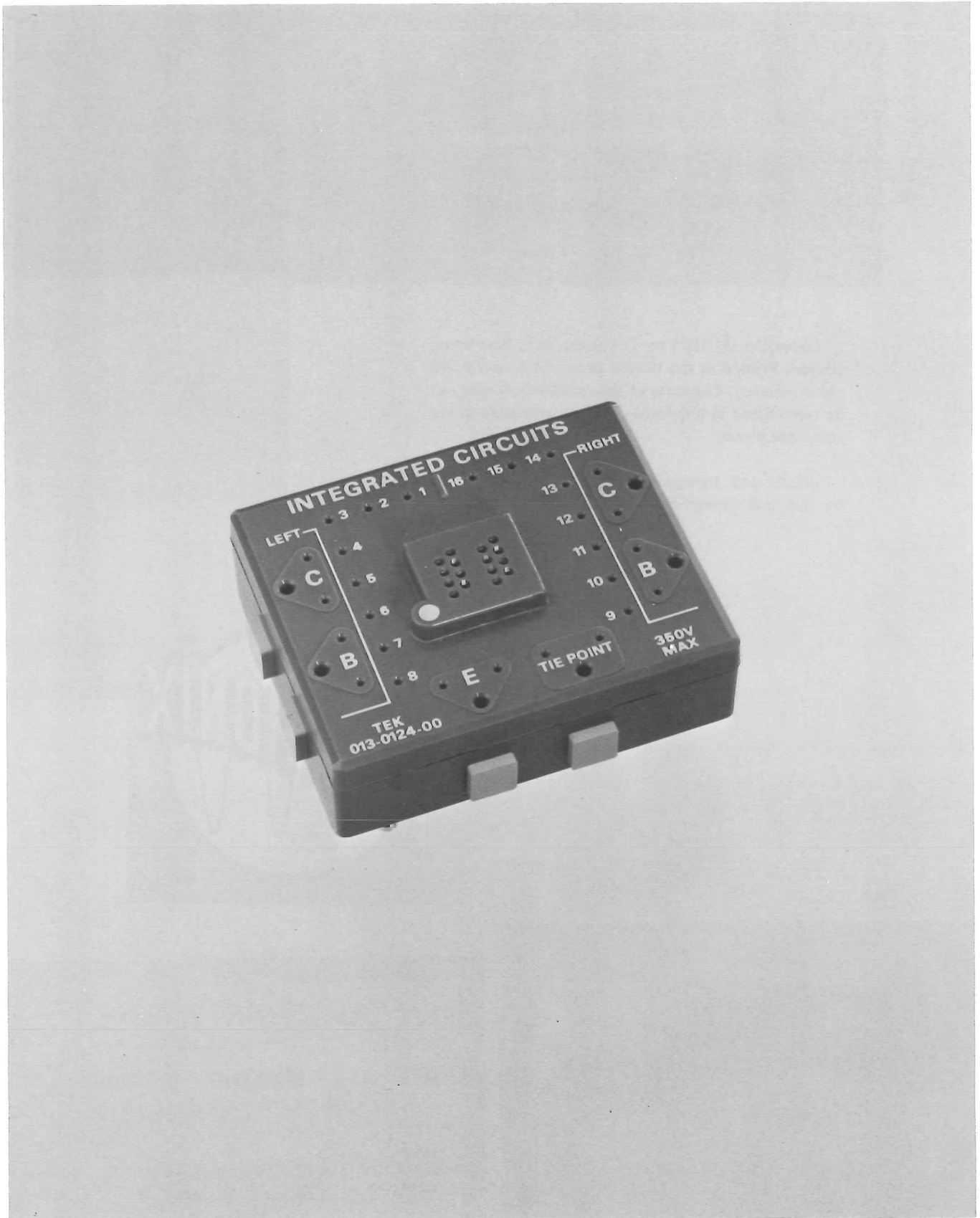

Fig. 1. Type 576 IC Adapter.

# TYPE 576 INTEGRATED CIRCUIT ADAPTER

**General**

The Type 576 Integrated Circuit Adapter (see Fig. 1) allows the Type 576 to make DC measurements on integrated circuits with up to 16 leads. It plugs into the device testing jacks of the Type 576 standard test fixture. Four sockets are available from Tektronix, which plug into the IC adapter and allow IC's with various package designs to be tested (see Fig. 2). Table 1 gives the Tektronix part number of each socket, along with the package type which may be tested. Other kinds of sockets which are useable with the IC adapter are available from Barnes Corp. in their RD-86 Series. For information, contact:

Barnes Corporation  
24 North Lansdowne Ave.  
Lansdowne, Pennsylvania 19050

**Limits**

Measurements made with the Type 576 using the IC adapter are limited to 350 volts and 50 watts. The Type 576 MAX PEAK VOLTS switch should not be set higher than 350 and the MAX-PEAK POWER WATTS switch should not be set above 50.

**Layout**

Sixteen of the jacks on the IC adapter are connected to the contactors on the socket being used (see Fig. 3). These jacks are numbered 1 through 16, which corresponds to the numbering of the contactors on the sockets as shown in Fig. 2. These jacks can be connected to the other jacks on the IC adapter through small patch wires supplied with the IC adapter.

The remainder of the jacks on the IC adapter are connected to the device testing jacks on the Standard Test Fixture, and to a common tie point. The collector (C) and base (B) jacks are used to apply power to the IC under test and to make measurements. There is a collector jack and a base jack on each side of the IC adapter. The Type 576 LEFT-OFF-RIGHT switch determines which set of jacks are in use. When the LEFT-OFF-RIGHT switch is set to OFF, both sets of jack are disconnected from the Type 576.

The emitter (E) jack on the left side of the IC adapter is normally used as a ground reference. It is connected to both emitter jacks on the Standard Test Fixture, and is not

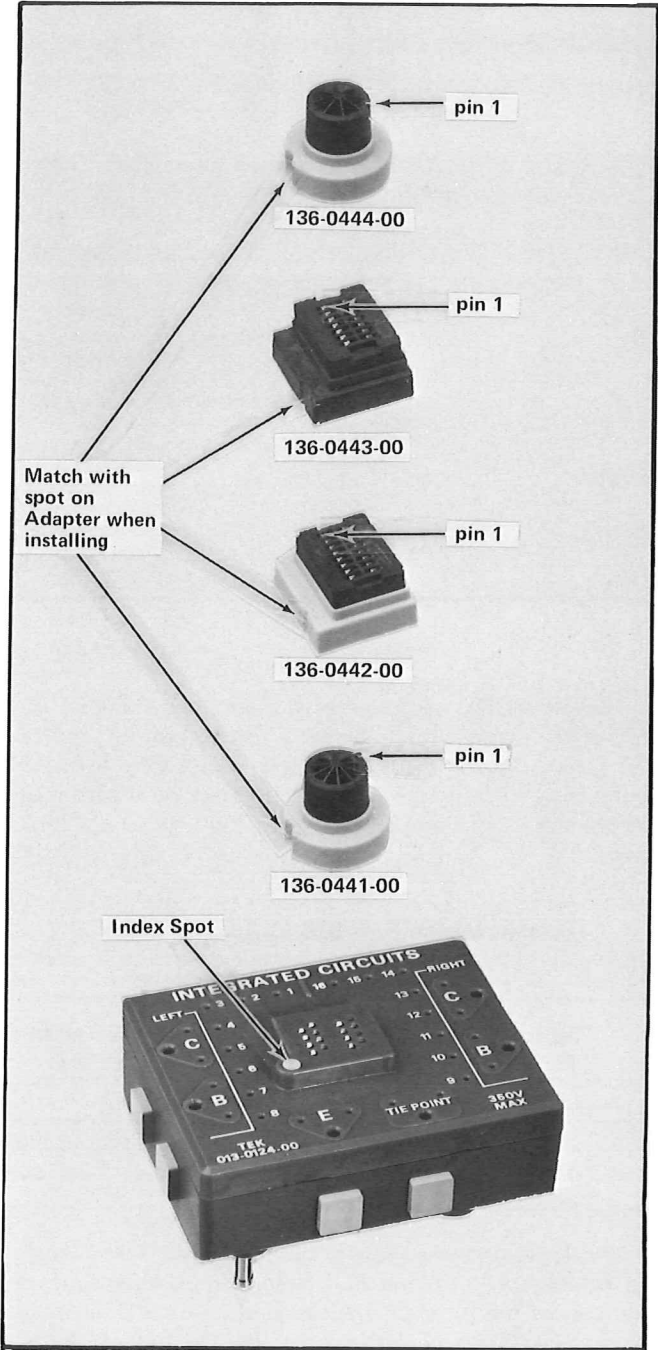

Fig. 2. Socket adapters for Type 576 IC Adapter.

affected by the LEFT-OFF-RIGHT switch. The emitter jack may thus be used for either position of the LEFT-OFF-RIGHT switch.

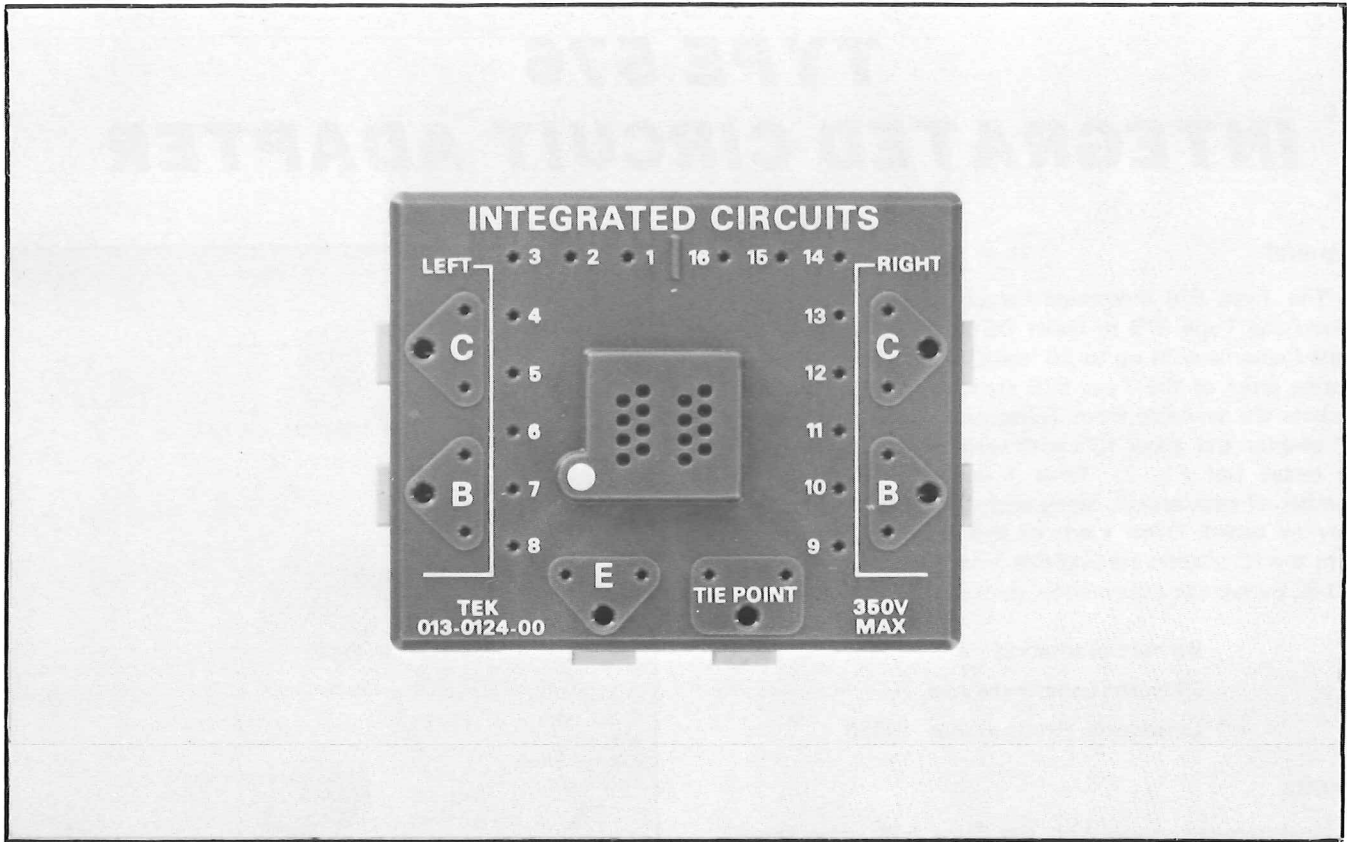

Fig. 3. Jacks on the Type 576 IC Adapter.

The TIE POINT jack is normally used as a tie point for an external power supply, which is required for some tests. The external power supply can be conveniently referenced to the Type 576 through the GROUND jack on the front of the Standard Test Fixture.

the collector jacks. The Collector Supply is used as a load. If a DC voltage is being measured, the VARIABLE COLLECTOR SUPPLY control is adjusted for the current specified for the test. If a DC current is being measured, the control is adjusted for the specified voltage.

TABLE 1

Sockets for the Type 576 IC Adapter Which Are Available From Tektronix

| Tektronix Part No. | IC Packages Which May Be Tested |              |
|--------------------|---------------------------------|--------------|
|                    | Package Type                    | No. of Leads |
| 136-0440-00        | TO                              | 10           |
| 136-0442-00        | Dual-In-Line                    | 16           |
| 136-0443-00        | Dual-In-Line                    | 14           |
| 136-0444-00        | TO                              | 8            |

The Kelvin sensing jacks on the Standard Test Fixture are not useable with the IC adapter. The pushbuttons on the sides of the IC adapter allow wires, loads or small plugs to be secured in the larger holes on the top of the IC adapter.

### Making Measurements

When using the Type 576 to make DC measurements on an IC, the measurements are normally made through one of

The base jacks are normally used as DC voltage sources.<sup>1</sup> The Step Generator is thus used as a DC voltage supply. The Step Generator is made into a voltage supply by setting the STEP GENERATOR AMPLITUDE switch to one of its voltage positions and pressing the SINGLE STEP FAMILY button. The OFFSET MULT control can then be used to adjust the DC voltage level when either the AID or OPPOSE OFFSET button is pressed. The Step Generator can also be used in its step mode. See step 6 at the end of this booklet for an example.

The emitter jack is normally used as a ground source. A ground is obtained on the emitter jack by setting the Terminal Selector switch to EMITTER GROUNDED, BASE TERM-STEP GEN.

<sup>1</sup> A base jack can also be used as a signal source by setting the Terminal Selector switch to BASE TERM OPEN (OR EXT) and applying a signal to the EXT BASE OR EMIT INPUT jack on the front of the Standard Test Fixture. The emitter jack can also be used as a signal source by setting the Terminal Selector Switch to EMITTER TERM OPEN (OR EXT).

There are three kinds of DC voltage measurements made on IC's:

1. Measuring a DC voltage while sinking or sourcing a specified DC current.
2. Measuring a DC voltage with a specified load.
3. Measuring a DC current while forcing a DC voltage.

DC voltage measurements are normally made on output pins of an IC. DC current measurements are normally made on input pins of an IC to determine forward and leakage current, on output pins to determine short circuit current, and on the V<sub>CC</sub> input pin to determine the total power supply drain.

In the following examples, the Collector Supply is operated in its sweep mode. This does not mean that non-DC measurements are being made. The displays merely show the operation of the device under a wide range of DC voltages or currents.

### Testing a 7400

The following example illustrates how the Type 576 with the IC adapter can be used to make DC measurements on a Type 7400 integrated circuit, which consists of four two-input positive NAND gates. Fig. 4 shows the specification published by Texas Instruments, Inc. for their SN7400. The figures which accompany this example show how the patch wires are connected to the IC adapter for each test. (In this case the device being tested is in a dual-in-line package.) Below each wiring diagram is a drawing of the gate being tested showing the jack each lead is connected to when the IC is plugged into the test socket. The figures show typical Type 576 CRT displays for the various tests. The following examples, except for example 6, show the testing of only one gate. Two gates can be conveniently checked at one time, however, by using the collector and base jacks on one side of the IC adapter for one gate, and the jacks on the other side for another gate. Two tests can then be made by simply switching the LEFT-OFF-RIGHT switch from one side to the other.

The following Type 576 control settings remain unchanged for the following examples. As a general rule, these controls can be set to the positions given for most tests made with the Type 576 and IC adapter.

TABLE 2

Type 576 Control Settings

| Control                          | Setting                                    |
|----------------------------------|--|
| POSITION (Vert. and Horiz.)      | Centered                                   |
| FINE POSITION (Vert. and Horiz.) | Centered                                   |
| DISPLAY OFFSET Selector          | NORM (OFF)                                 |
| CENTERLINE VALUE                 | 0.0  |
| DISPLAY INVERT                   | Released                                   |
| ZERO                             | Not Pressed                                |
| CAL                              | Not Pressed                                |
| NUMBER OF STEPS                  | 1  |
| STEP GENERATOR                   |  |
| AMPLITUDE                        | 1 V  |
| CURRENT LIMIT                    | 100 mA                                     |
| OFFSET                           | AID  |
| STEPS                            | Pressed                                    |
| STEP FAMILY                      | SINGLE                                     |
| RATE                             | NORM                                       |
| STEP MULT .1X                    | Released                                   |
| POLARITY INVERT                  | Released                                   |
| MAX PEAK VOLTS                   | 15   |
| MODE                             | NORM                                       |
| LOOPING COMPENSATION             | As Is                                      |
| Terminal Selector                | EMITTER<br>GROUNDED, BASE<br>TERM-STEP GEN |

### 1. Measure V<sub>out(1)</sub> with V<sub>in(0)</sub>

At least one input terminal of a 7400 gate must be held at a logical 0 to get a logical 1 at the output terminal of that gate. Thus, this test must be performed twice, once for each input.

- a. Set the Type 576 controls not set in Table 2, as follows:

|                           |                        |
|---------------------------|------------------------|
| VERTICAL                  | .1 mA                  |
| HORIZONTAL                | 1 V                    |
| OFFSET MULT               | 0.8                    |
| SERIES RESISTORS          | 14 k                   |
| VARIABLE COLLECTOR SUPPLY | Fully Counterclockwise |
| COLLECTOR SUPPLY POLARITY | AC                     |
| LEFT-OFF-RIGHT            | OFF                    |

- b. Connect the patch wires to the IC adapter as shown in Fig. 5.

## CIRCUIT TYPES SN5400, SN7400 QUADRUPLE 2-INPUT POSITIVE NAND GATES

schematic (each gate)

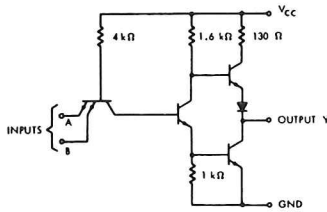

NOTE: Component values shown are nominal.

F FLAT PACKAGE  
(TOP VIEW)

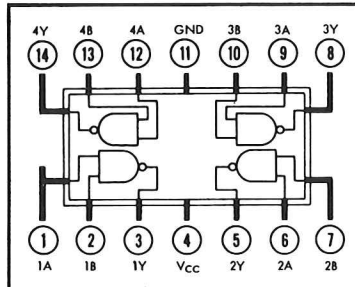

J OR N DUAL-IN-LINE PACKAGE  
(TOP VIEW)

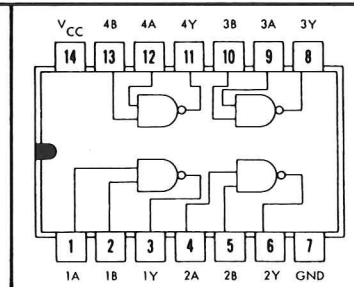

positive logic:  $Y = \overline{AB}$

**recommended operating conditions**

|   |                 |      |    |      |    |
|---|-----------------|------|----|------|----|
| Supply Voltage $V_{CC}$ :                     | SN5400 Circuits | 4.5  | 5  | 5.5  | V  |
|   | SN7400 Circuits | 4.75 | 5  | 5.25 | V  |
| Normalized Fan-Out From Each Output, N        |                 |      |    | 10   |    |
| Operating Free-Air Temperature Range, $T_A$ : | SN5400 Circuits | -55  | 25 | 125  | °C |
|   | SN7400 Circuits | 0    | 25 | 70   | °C |

| MIN  | NOM | MAX  | UNIT |
|------|-----|------|------|
| 4.5  | 5   | 5.5  | V    |
| 4.75 | 5   | 5.25 | V    |
|      |     | 10   |      |
| -55  | 25  | 125  | °C   |
| 0    | 25  | 70   | °C   |

**electrical characteristics (over recommended operating free-air temperature range unless otherwise noted)**

| PARAMETER   | TEST FIGURE | TEST CONDITIONS†   | MIN    | TYP‡ | MAX  | UNIT |
|---|-------------|--|--------|------|------|------|
| $V_{in(1)}$ Logical 1 input voltage required at both input terminals to ensure logical 0 level at output  | 1           | $V_{CC} = \text{MIN}$  | 2      |      |      | V    |
| $V_{in(0)}$ Logical 0 input voltage required at either input terminal to ensure logical 1 level at output | 2           | $V_{CC} = \text{MIN}$  |        |      | 0.8  | V    |
| $V_{out(1)}$ Logical 1 output voltage   | 2           | $V_{CC} = \text{MIN}$ , $V_{in} = 0.8 \text{ V}$ , $I_{load} = -400 \mu\text{A}$                     | 2.4    | 3.3  |      | V    |
| $V_{out(0)}$ Logical 0 output voltage   | 1           | $V_{CC} = \text{MIN}$ , $V_{in} = 2 \text{ V}$ , $I_{sink} = 16 \text{ mA}$                          | 0.22   | 0.4  |      | V    |
| $I_{in(0)}$ Logical 0 level input current (each input)  | 3           | $V_{CC} = \text{MAX}$ , $V_{in} = 0.4 \text{ V}$   |        |      | -1.6 | mA   |
| $I_{in(1)}$ Logical 1 level input current (each input)  | 4           | $V_{CC} = \text{MAX}$ , $V_{in} = 2.4 \text{ V}$<br>$V_{CC} = \text{MAX}$ , $V_{in} = 5.5 \text{ V}$ |        |      | 40   | μA   |
| $I_{OS}$ Short-circuit output current§  | 5           | $V_{CC} = \text{MAX}$  | SN5400 | -20  | -55  | mA   |
|   |             |  | SN7400 | -18  | -55  | mA   |
| $I_{CC(0)}$ Logical 0 level supply current  | 6           | $V_{CC} = \text{MAX}$ , $V_{in} = 5 \text{ V}$   |        | 12   | 22   | mA   |
| $I_{CC(1)}$ Logical 1 level supply current  | 6           | $V_{CC} = \text{MAX}$ , $V_{in} = 0$   |        | 4    | 8    | mA   |

**switching characteristics,  $V_{CC} = 5 \text{ V}$ ,  $T_A = 25^\circ\text{C}$ ,  $N = 10$**

| PARAMETER   | TEST FIGURE | TEST CONDITIONS                            | MIN | TYP | MAX | UNIT |
|---|-------------|--|-----|-----|-----|------|
| $t_{pd0}$ Propagation delay time to logical 0 level | 65          | $C_L = 15 \text{ pF}$ , $R_L = 400 \Omega$ |     | 7   | 15  | ns   |
| $t_{pd1}$ Propagation delay time to logical 1 level | 65          | $C_L = 15 \text{ pF}$ , $R_L = 400 \Omega$ |     | 11  | 22  | ns   |

† For conditions shown as MIN or MAX, use the appropriate value specified under recommended operating conditions for the applicable device type.

‡ All typical values are at  $V_{CC} = 5 \text{ V}$ ,  $T_A = 25^\circ\text{C}$ .

§ Not more than one output should be shorted at a time.

Fig. 4. Specification for SN7400 reprinted from the "TTL Integrated Circuits Catalog" from Texas Instruments with permission from Texas Instruments, Inc.

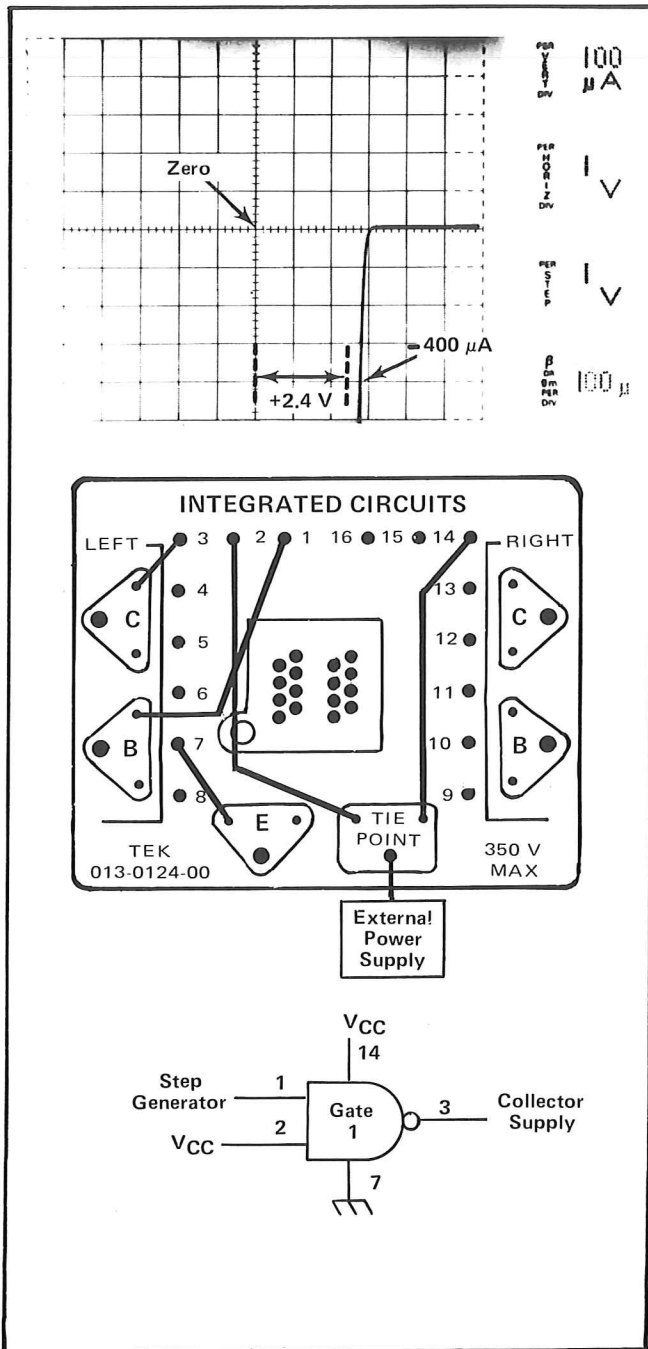

Fig. 5. Setup and Type 576 display for measuring  $V_{out}(1)$  with  $V_{in}(o)$ .

c. Connect an external power supply to the TIE POINT jack.

d. Set the LEFT-OFF-RIGHT switch to LEFT and adjust the external power supply for 4.75 V.

e. Turn the VARIABLE COLLECTOR SUPPLY control clockwise until the gate output is conducting at least  $-400 \mu A$  (see the display in Fig. 5).

f. Check that  $V_{out}$  is at least 2.4 V at  $-400 \mu A$ .

g. Increase  $V_{in}$  with the OFFSET MULT control until  $V_{out}$  is at 2.4 V at  $-400 \mu A$ . The reading on the OFFSET MULT dial is the maximum  $V_{in}$  on the input terminal being tested which will produce a  $V_{out}(1)$  on the output. Reset the OFFSET MULT control to 0.8 V.

h. Set the LEFT-OFF-RIGHT switch to OFF. Connect jack 1 of the IC adapter (the 1A input to the gate) to the TIE POINT jack ( $V_{CC}$ ) and jack 2 the 1B input) to the left base jack ( $V_{in}(0)$ ). Set the LEFT-OFF-RIGHT switch to LEFT.

i. Repeat parts e through g for the 1B gate input.

## 2. Measure $V_{out}(0)$ with $V_{in}(1)$

Both input terminals of a 7400 gate must be held at a logical 1 to get a logical 0 at the output terminal of that gate.

a. Set the Type 576 controls not set in Table 2, as follows:

|                           |                        |
|---------------------------|------------------------|
| VERTICAL                  | 2 mA                   |
| HORIZONTAL                | .1 V                   |
| OFFSET MULT               | 2.0                    |
| SERIES RESISTORS          | 650                    |
| VARIABLE COLLECTOR SUPPLY | Fully Counterclockwise |
| COLLECTOR SUPPLY POLARITY | + (NPN)                |
| LEFT-OFF-RIGHT            | OFF                    |

b. Connect the patch wires to the IC adapter as shown in Fig. 6.

c. Connect the external power supply to the IC adapter and set it to the specified  $V_{CC}$  as discussed in step 1 parts c and d.

d. Set the LEFT-OFF-RIGHT switch to LEFT and turn the VARIABLE COLLECTOR SUPPLY control clockwise until the gate output conducts at least 16 mA (see the display in Fig. 6).

e. Check for a  $V_{out}$  of not more than 0.4 V at 16 mA.

f. Reduce  $V_{in}$  with the OFFSET MULT control until  $V_{out}$  is at 0.4 V at 16 mA. The reading on the OFFSET

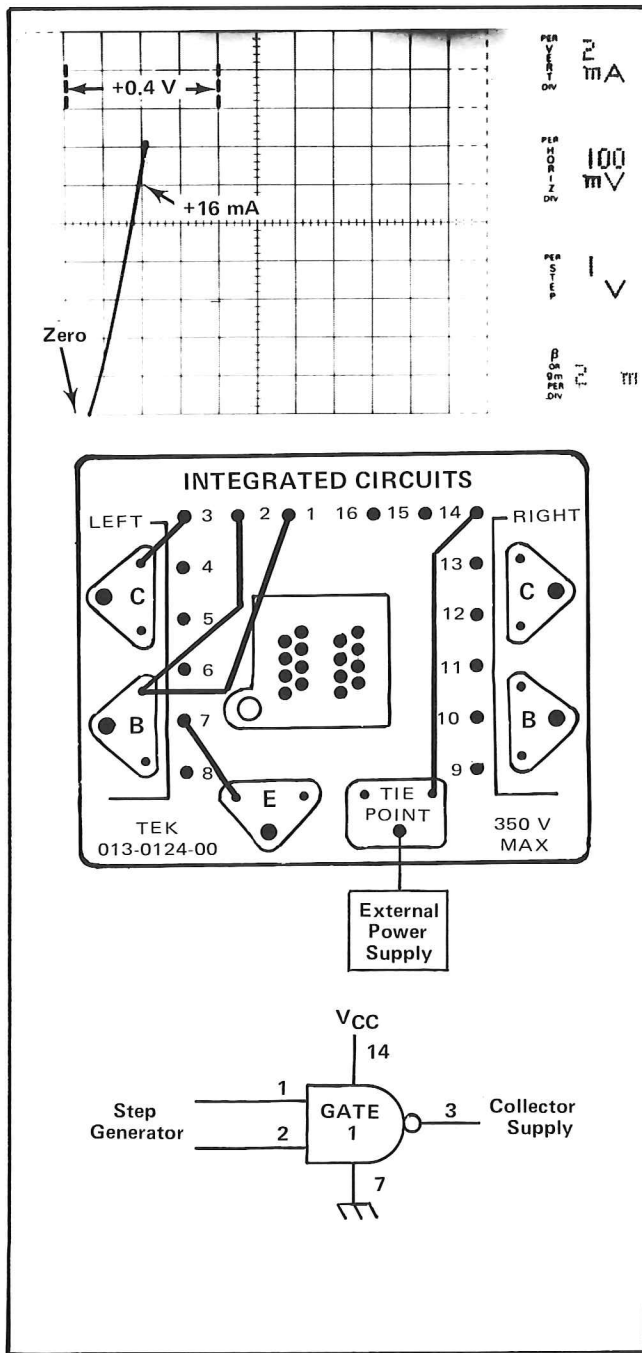

Fig. 6. Setup and Type 576 display for measuring  $V_{out}$  (o) with  $V_{in}$  (1).

MULT dial is the minimum  $V_{in}$  on both input terminals which will produce a  $V_{out}(0)$  at the output.

### 3. Measure $I_{in}(0)$

This test must be performed twice, once for each gate tested, as in step 1.

a. Set the Type 576 controls not set in Table 2, as follows:

|                           |                        |
|---------------------------|------------------------|
| VERTICAL                  | .5 mA                  |
| HORIZONTAL                | .5 V                   |
| OFFSET MULT               | 5.25                   |
| SERIES RESISTORS          | 650                    |
| VARIABLE COLLECTOR SUPPLY | Fully counterclockwise |
| COLLECTOR SUPPLY POLARITY | AC                     |
| LEFT-OFF-RIGHT            | OFF                    |

b. Connect the patch wires to the IC adapter as shown in Fig. 7.<sup>2</sup>

c. Set the LEFT-OFF-RIGHT switch to LEFT and turn the VARIABLE COLLECTOR SUPPLY clockwise until the input voltage is at 0.4 V (see the display in Fig. 7).

d. Check for  $I_{in}$  of not more than  $-1.6$  mA at 0.4 V  $V_{in}$ .

e. Set the LEFT-OFF-RIGHT switch to OFF. Connect jack 1 (1A) to the left base jack ( $V_{CC}$ ) and jack 2 (1B) to the left collector jack ( $V_{in}$ ).

f. Repeat parts c and d for the 1B gate input.

### 4. Measure $I_{in}(1)$

This test must be performed twice, once for each input, as in step 1.

a. Set the Type 576 controls not set in Table 2, as follows:

|                           |                        |
|---------------------------|------------------------|
| VERTICAL                  | $1 \mu A$              |
| HORIZONTAL                | 1 V                    |
| OFFSET MULT               | 5.25                   |
| SERIES RESISTORS          | 14 k                   |
| VARIABLE COLLECTOR SUPPLY | Fully Counterclockwise |
| COLLECTOR SUPPLY POLARITY | AC                     |
| LEFT-OFF-RIGHT            | OFF                    |

b. Connect the patch wires to the IC adapter as shown in Fig. 8.<sup>2</sup>

<sup>2</sup>Either an external power supply or the step generator can be used for  $V_{CC}$  in this test.



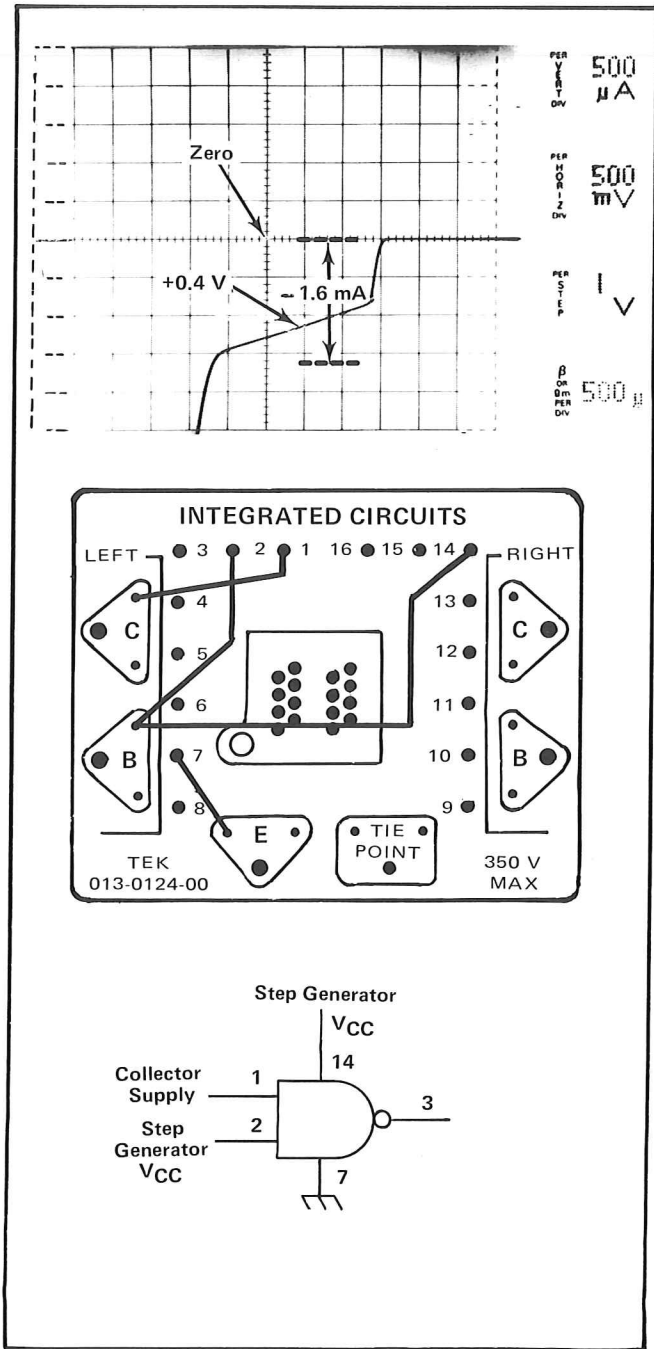

Fig. 7. Setup and Type 576 display for measuring  $I_{IN} (0)$ .

c. Set the LEFT-OFF-RIGHT switch to LEFT and turn the VARIABLE COLLECTOR SUPPLY control clockwise until the input voltage is at +5.25 V (see the display in Fig. 8).

d. Check for  $I_{IN}$  of not more than  $40 \mu A$  at +2.4 V  $V_{IN}$ .

e. Check for  $I_{IN}$  of not more than 1 mA at +5.25 V  $V_{IN}$ .

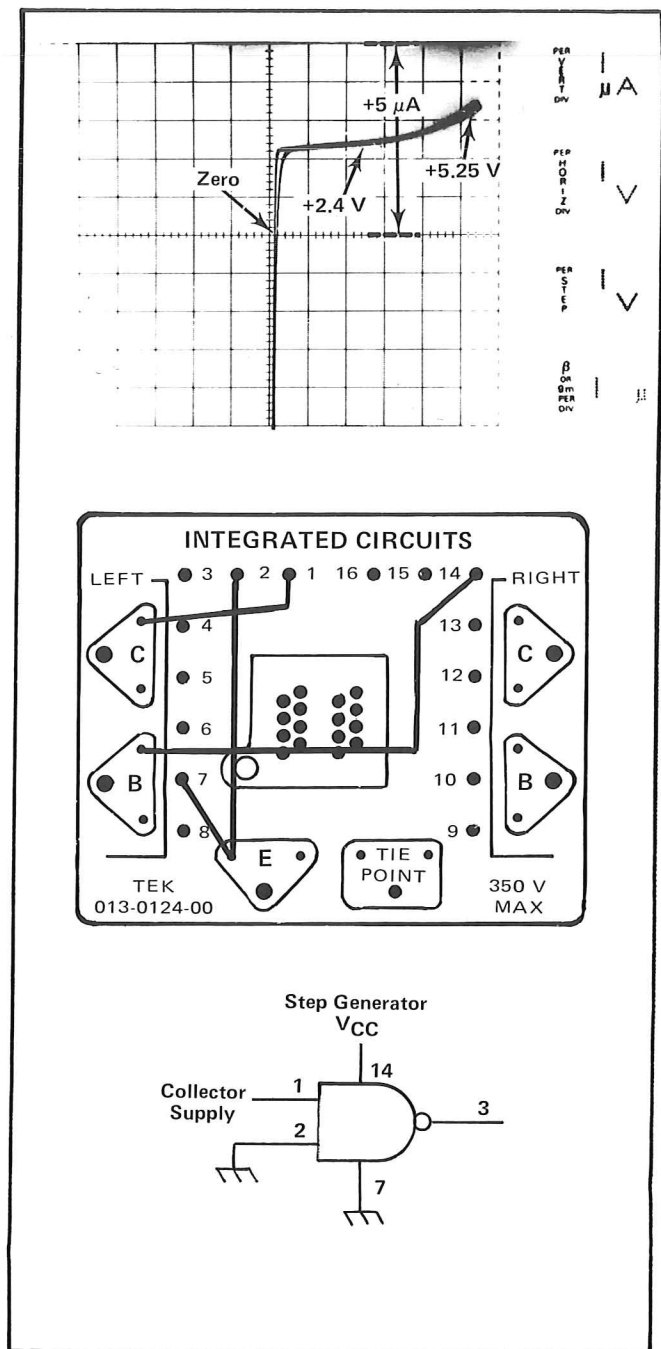

Fig. 8. Setup and Type 576 display for measuring  $I_{IN} (1)$ .

f. Set the LEFT-OFF-RIGHT switch to OFF. Connect jack 1 (1A) to the emitter jack (ground) and the jack 2 (1B) to the collector jack ( $V_{IN}$ ).

g. Repeat parts c through e for the  $I_B$  gate input.

## 5. Measure $I_{OS}$

a. Set the Type 576 controls not set in Table 2, as follows:

Type 576 IC Adapter—013-0124-00

|                           |                        |
|---------------------------|------------------------|
| VERTICAL                  | 10 mA                  |
| HORIZONTAL                | .2 V                   |
| OFFSET MULT               | 5.25                   |
| SERIES RESISTORS          | 30                     |
| VARIABLE COLLECTOR SUPPLY | Fully counterclockwise |
| COLLECTOR SUPPLY POLARITY | AC                     |
| LEFT-OFF-RIGHT            | OFF                    |

b. Connect the patch wires to the IC adapter as shown in Fig. 9.<sup>2</sup>

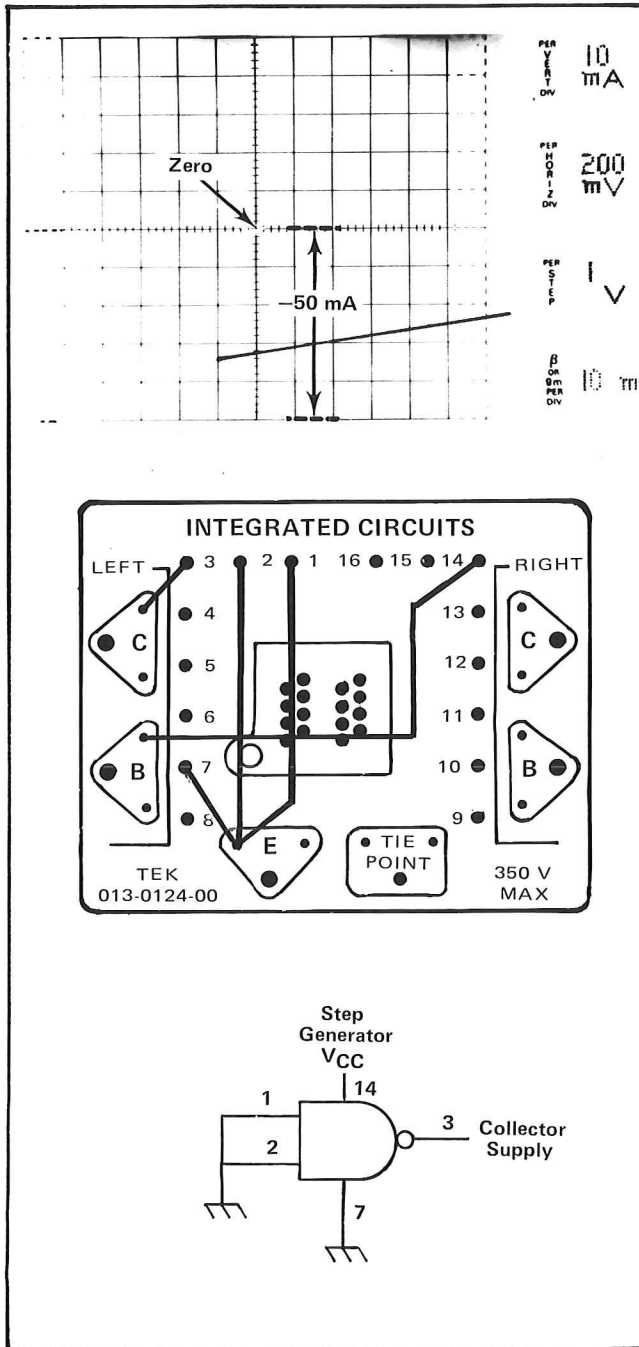

Fig. 9. Setup and Type 576 display for measuring  $I_{OS}$ .

c. Set the LEFT-OFF-RIGHT switch to LEFT and turn the VARIABLE COLLECTOR SUPPLY control clockwise until  $V_{out}$  is 0 volts (see the display in Fig. 9).

d. Check that the output current is between  $-18$  mA and  $-55$  mA.

6. Measure  $I_{CC}(0)$  and  $I_{CC}(1)$

a. Set the Type 576 controls not shown in table 2, as follows:

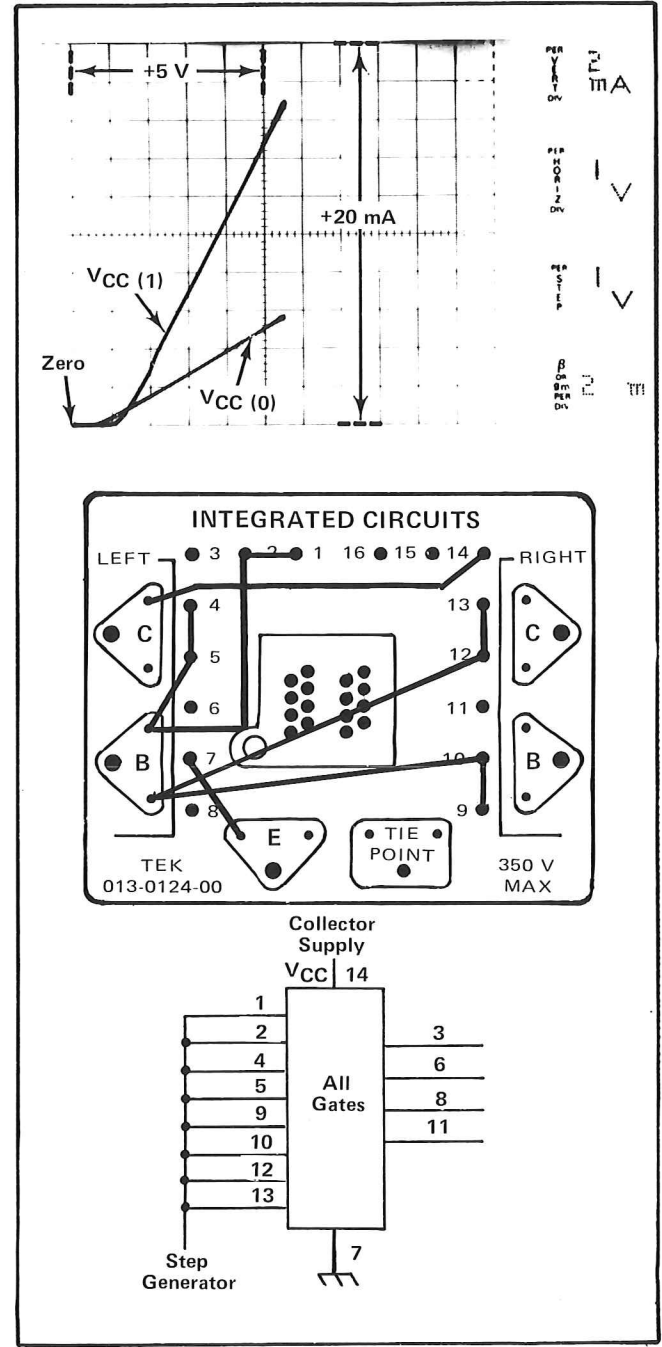

Fig. 10. Setup and Type 576 display for measuring  $V_{CC \max}$ .

|                              |                        |
|------------------------------|------------------------|
| VERTICAL                     | 2 mA                   |
| HORIZONTAL                   | 1 V                    |
| OFFSET MULT                  | 5.0                    |
| SERIES RESISTORS             | 650                    |
| VARIABLE COLLECTOR<br>SUPPLY | Fully counterclockwise |
| COLLECTOR SUPPLY<br>POLARITY | + (NPN)                |
| LEFT-OFF-RIGHT               | OFF                    |

b. Connect the patch wires to the IC adapter as shown in Fig. 10.<sup>2</sup>

c. Set the LEFT-OFF-RIGHT switch to LEFT and turn the VARIABLE COLLECTOR SUPPLY control until  $V_{CCmax}$  is obtained, 5.25 V (see the display in Fig. 10).

d. Check for  $I_{CC(0)}$  of between 12 mA and 22 mA.

e. Press the ZERO OFFSET button and readjust the VARIABLE COLLECTOR SUPPLY control if necessary.

f. Check for  $I_{CC(1)}$  of between 4 mA and 8 mA.

*NOTE*

*$I_{CC(0)}$  and  $I_{CC(1)}$  can be measured at the same time by setting the NUMBER OF STEPS switch to 5 and pressing the ZERO OFFSET and STEP FAMILY REP buttons.*

# REPLACEMENT PARTS

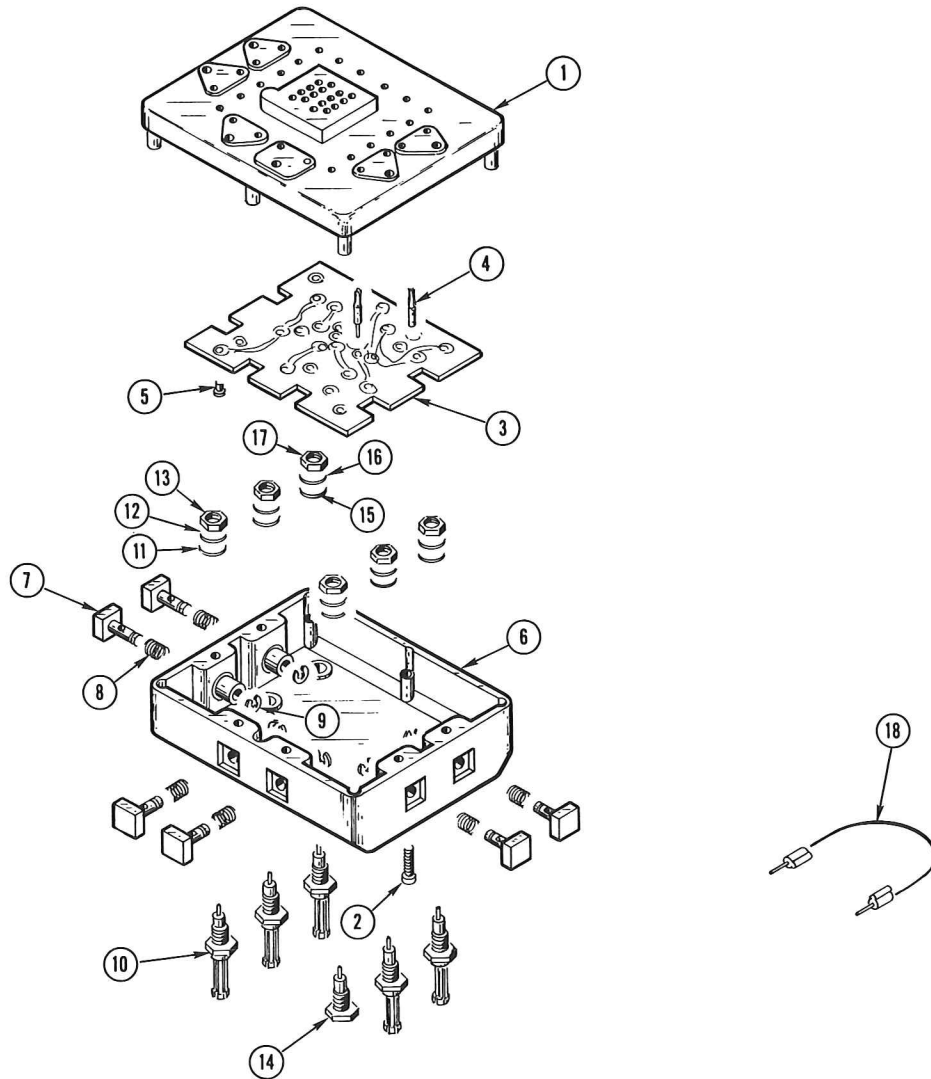

| Fig. & Index No. | Tektronix Part No. | Serial/Model No. |      | Q | † | y                                      | Description                               |
|------------------|--------------------|------------------|------|---|---|--|---|
|                  |                    | Eff              | Disc |   |   |  |   |
| 1                | 013-0124-01        |                  |      | 1 |   |  | TEST ADAPTER, IC, 576, w/test leads       |
|                  | - - - - -          |                  |      | - |   |  | test adapter includes:                    |
|                  | 013-0124-00        |                  |      | 1 |   |  | TEST ADAPTER, w/o test leads              |
|                  | - - - - -          |                  |      | - |   |  | test adapter includes:                    |
|                  | 200-1198-01        |                  |      | 1 |   |  | COVER, test adapter                       |
|                  | - - - - -          |                  |      | - |   |  | mounting hardware: (not included w/cover) |
|                  | 213-0214-00        |                  |      | 6 |   |  | SCREW, 2-56 x 0.375 inch, cap HS          |
|                  | 670-1425-00        |                  |      | 1 |   |  | CIRCUIT BOARD ASSEMBLY                    |
|                  | - - - - -          |                  |      | - |   |  | circuit board assembly includes:          |
|                  | 388-1980-00        |                  |      | 1 |   |  | CIRCUIT BOARD                             |
| 131-1079-00      |                    |                  | 44   |   |   | CONTACT, electrical                    |   |
| 136-0261-00      |                    |                  | 6    |   |   | SOCKET, connector pin, 0.145 inch long |   |
| 202-0177-01      |                    |                  | 1    |   |   | BOX, test adapter                      |   |

# REPLACEMENT PARTS (cont)

| Fig. &<br>Index<br>No. | Tektronix<br>Part No. | Serial/Model No. |      | Q |    |   |   |   | Description |   |   |   |
|------------------------|-----------------------|------------------|------|---|----|---|---|---|-------------|---|---|---|
|                        |                       | Eff              | Disc | t | y  | 1 | 2 | 3 |             | 4 | 5 |   |
| 7                      | 366-1100-00           |                  |      |   | 6  |   |   |   |             |   | 6 | KNOB, pushbutton                                  |
|                        | - - - - -             |                  |      |   | -  |   |   |   |             |   |   | mounting hardware for each: (not include w/knob)  |
| 8                      | 214-1160-00           |                  |      |   | 1  |   |   |   |             |   |   | SPRING, helical, 0.24 inch long                   |
| 9                      | 354-0350-00           |                  |      |   | 1  |   |   |   |             |   |   | RING, retaining                                   |
| 10                     | 134-0108-00           |                  |      |   | 5  |   |   |   |             |   |   | PLUG, tip, threaded 6-32                          |
|                        | - - - - -             |                  |      |   | -  |   |   |   |             |   |   | mounting hardware for each: (not included w/plug) |
| 11                     | 210-0006-00           |                  |      |   | 1  |   |   |   |             |   |   | WASHER, lock, internal, 0.146 ID x 0.283 inch OD  |
| 12                     | 210-0802-00           |                  |      |   | 1  |   |   |   |             |   |   | WASHER, flat, 0.15 ID x 0.312 inch OD             |
| 13                     | 210-0407-00           |                  |      |   | 1  |   |   |   |             |   |   | NUT, hex., 6-32 x 0.25 inch                       |
| 14                     | 134-0133-00           |                  |      |   | 1  |   |   |   |             |   |   | PLUG, tip, dummy                                  |
|                        | - - - - -             |                  |      |   | -  |   |   |   |             |   |   | mounting hardware: (not included w/plug)          |
| 15                     | 210-0006-00           |                  |      |   | 1  |   |   |   |             |   |   | WASHER, lock, internal, 0.146 ID x 0.283 inch OD  |
| 16                     | 210-0802-00           |                  |      |   | 1  |   |   |   |             |   |   | WASHER, flat, 0.15 ID x 0.312 inch OD             |
| 17                     | 210-0407-00           |                  |      |   | 1  |   |   |   |             |   |   | NUT, hex., 6-32 x 0.25 inch                       |
| 18                     | 012-0310-00           |                  |      |   | 8  |   |   |   |             |   |   | LEAD, test, yellow, 4 inches long                 |
| ELECTRICAL PARTS       |                       |                  |      |   |    |   |   |   |             |   |   |   |
|                        | 120-0407-00           |                  |      |   | 6  |   |   |   |             |   |   | TRANSFORMER, toroid, 5 turns                      |
|                        | 276-0621-00           |                  |      |   | 16 |   |   |   |             |   |   | CORE, ferrite                                     |

