

User Manual

JHB

**Tektronix**

---

**CSS500**  
**Cable Television System Software**  
**070-8806-03**





# User Manual

**Tektronix**

**CSS500**

**Cable Television System Software**

**070-8806-03**

Copyright © Tektronix, Inc. 1993. All rights reserved. Licensed software products are owned by Tektronix or its suppliers and are protected by United States copyright laws and international treaty provisions.

Use, duplication, or disclosure by the Government is subject to restrictions as set forth in subparagraph (c)(1)(ii) of the Rights in Technical Data and Computer Software clause at DFARS 252.227-7013, or subparagraphs (c)(1) and (2) of the Commercial Computer Software – Restricted Rights clause at FAR 52.227-19, as applicable.

Tektronix products are covered by U.S. and foreign patents, issued and pending. Information in this publication supercedes that in all previously published material. Specifications and price change privileges reserved.

Printed in the U.S.A.

Tektronix, Inc., P.O. Box 1000, Wilsonville, OR 97070-1000

TEKTRONIX and TEK are registered trademarks of Tektronix, Inc.

## WARRANTY

Tektronix warrants that this software product will conform to the specifications in the documentation provided with the product, when used properly in the specified operating environment, for a period of three (3) months. The warranty period begins on the date of shipment, except that if the program is installed by Tektronix, the warranty period begins on the date of installation or one month after the date of shipment, whichever is earlier. If this software product does not conform as warranted, Tektronix will provide remedial services as described in the documentation provided with the product.

Tektronix does not warrant that the functions contained in this software product will meet Customer's requirements or that operation of the programs will be uninterrupted or error-free or that all errors will be corrected.

In order to obtain service under this warranty, Customer must notify Tektronix of the defect before the expiration of the warranty period and make suitable arrangements for such service in accordance with the instructions received from Tektronix. If Tektronix is unable, within a reasonable time after receipt of such notice, to provide remedial services, Customer may terminate the license for this software product and return this software product and any associated materials to Tektronix for credit or refund.

This warranty shall not apply to any software product that has been modified or altered by Customer. Tektronix shall not be obligated to furnish service under this warranty with respect to any software product a) that is used in an operating environment other than that specified or in a manner inconsistent with the User's Manual and documentation or b) when the software product has been integrated with other software if the result of such integration increases the time or difficulty of analyzing or servicing the software product or the problems ascribed to the software product.

**THIS WARRANTY IS GIVEN BY TEKTRONIX IN LIEU OF ANY OTHER WARRANTIES, EXPRESS OR IMPLIED. TEKTRONIX AND ITS VENDORS DISCLAIM ANY IMPLIED WARRANTIES OF MERCHANTABILITY OR FITNESS FOR A PARTICULAR PURPOSE. TEKTRONIX' RESPONSIBILITY TO PROVIDE REMEDIAL SERVICE WHEN SPECIFIED, REPLACE DEFECTIVE MEDIA, OR REFUND CUSTOMER'S PAYMENT IS THE SOLE AND EXCLUSIVE REMEDY PROVIDED TO CUSTOMER FOR BREACH OF THIS WARRANTY. TEKTRONIX AND ITS VENDORS WILL NOT BE LIABLE FOR ANY INDIRECT, SPECIAL, INCIDENTAL, OR CONSEQUENTIAL DAMAGES IRRESPECTIVE OF WHETHER TEKTRONIX OR THE VENDOR HAS ADVANCE NOTICE OF THE POSSIBILITY OF SUCH DAMAGES.**



# Table of Contents

Customer Support .....	v
What's in this Manual .....	v

## Getting Started

<b>Installation .....</b>	<b>1-1</b>
Contents of CSS500 Package .....	1-1
Hardware Requirements .....	1-1
Software Installation .....	1-2
Step-by-Step Procedure to Install the CSS500 Software .....	1-2
Results of the Software Installation .....	1-3
Hardware Installation .....	1-4
Test Equipment .....	1-5
To Install the Equipment .....	1-6
Select the Correct Demodulator and Configure the Connections .....	1-8
Upgrade From the MS-DOS Based Tektronix Cable TV Software .....	1-11

## Operating Basics

<b>Basic Tutorial .....</b>	<b>2-1</b>
What Can CSS500 Do? .....	2-2
Start CSS500 .....	2-2
Description of the Worksheet .....	2-3
Navigation .....	2-5
Set Up a Worksheet .....	2-13
Make Simple Measurements .....	2-17
Define and Use a Measurement Sequence .....	2-25
Display the Picture (Optional) .....	2-35
Print (Optional) .....	2-35
End of the Tutorial .....	2-37
<b>Advanced Setups Tutorial .....</b>	<b>2-39</b>
Select and Configure the Demodulator .....	2-39
Configure Connections .....	2-40
Configure Measurement Setups .....	2-41
Attach a Different Channel Table .....	2-49
Configuration Preferences .....	2-51
Review .....	2-58
<b>Advanced Measurements Tutorial .....</b>	<b>2-59</b>
Reset the Preferences and Worksheet for this Chapter .....	2-59
Results Detail Display .....	2-60
Status Report and View Violations Displays .....	2-62
Copy and Export .....	2-66
View Filters .....	2-73
Defining Limits .....	2-79
The 2714/2715 User Defined Program (UDP) .....	2-86
Get Stored Results from the 2714/2715 .....	2-89

## Reference

<b>Overview</b> .....	<b>3-1</b>
<b>Parts of the Worksheet</b> .....	<b>3-3</b>
Title Bar .....	3-3
Minimize Button .....	3-4
Maximize Button .....	3-4
Restore Button .....	3-4
Worksheet Header .....	3-4
Channel Header .....	3-5
Measurement Header .....	3-6
Vertical Scroll Bar .....	3-7
Horizontal Scroll Bar .....	3-7
Cursor .....	3-8
<b>Control Menu Box</b> .....	<b>3-9</b>
Restore .....	3-9
Move .....	3-9
Size .....	3-10
Minimize .....	3-10
Maximize .....	3-10
Close .....	3-10
Switch To .....	3-10
<b>Menu Bar</b> .....	<b>3-11</b>
File .....	3-11
Edit .....	3-23
View .....	3-26
Measure .....	3-45
Configure .....	3-49
Execute .....	3-84
Help .....	3-84
Button Bar .....	3-86

## Appendices

<b>Appendix A: Menu Map</b> .....	<b>A-1</b>
<b>Appendix B: Error, Warning, and Informational Messages</b> .....	<b>B-1</b>
Error Messages .....	B-1
Warning Messages .....	B-9
Informational Messages .....	B-10
<b>Appendix C: Channel Table Editor</b> .....	<b>C-1</b>
Starting the Channel Table Editor .....	C-2
Creating a New Channel Table .....	C-3
Creating a Channel Table from an Existing Channel Table .....	C-5
Loading a Channel Table into the Test Equipment .....	C-9
Cautions .....	C-9
Channel Tables Provided .....	C-12
Overview .....	C-14
Button Bar .....	C-28
Channel Table Fields .....	C-29



<b>Appendix D: FCC Measurements</b> .....	<b>D-1</b>
Organizing Worksheets and Measurement Results .....	D-1
FCC Headend Measurements .....	D-3
FCC Field Measurements .....	D-5
<b>Appendix E: CSS500 Files</b> .....	<b>E-1</b>
Approximate File Sizes .....	E-1
File Naming Conventions .....	E-2
User Aids .....	E-2
How to Archive a Worksheet .....	E-5
The WIN.INI File .....	E-6
The CSS500.INI File .....	E-6
<b>Appendix F: Wiring Diagram</b> .....	<b>F-1</b>
<b>Appendix G: Controlling a 2714/2715 Over a Modem</b> .....	<b>G-1</b>
Terminal Program Settings .....	G-1
Local Modem Settings .....	G-2
Remote Modem Settings .....	G-2
271X Settings .....	G-3

Glossary  
Index



# List of Figures

Figure 1-1: The Demodulator selection, from the Configure menu ..	1-9
Figure 1-2: The Demodulator Setups dialog box .....	1-9
Figure 1-3: The Connections dialog box when TDC-10/1450A is selected as the demodulator .....	1-10
Figure 2-1: The default worksheet .....	2-3
Figure 2-2: The Worksheet Header .....	2-5
Figure 2-3: The drop-down File menu .....	2-6
Figure 2-4: The Open dialog box .....	2-7
Figure 2-5: The Test ID dialog box .....	2-8
Figure 2-6: The spreadsheet scrolled to the ICPM column .....	2-10
Figure 2-7: Example of a cell selected on the spreadsheet. ....	2-11
Figure 2-8: A group of cells selected .....	2-12
Figure 2-9: Warning dialog box .....	2-13
Figure 2-10: The New dialog box .....	2-14
Figure 2-11: The Save As dialog box .....	2-15
Figure 2-12: The initial display of the Test ID dialog box .....	2-16
Figure 2-13: The worksheet header after filling in all information ..	2-16
Figure 2-14: Measurement Execution dialog box .....	2-18
Figure 2-15: Message dialog box .....	2-18
Figure 2-16: Measurement Execution Dialog box .....	2-19
Figure 2-17: The spreadsheet after making a few measurements ...	2-19
Figure 2-18: Measurement Execution dialog box .....	2-20
Figure 2-19: RF Signal dialog box .....	2-20
Figure 2-20: Execution dialog box .....	2-21
Figure 2-21: The spreadsheet cells after making a group of measurements ..	2-21
Figure 2-22: The Results Detail dialog box .....	2-22
Figure 2-23: The Global View of the spreadsheet .....	2-24
Figure 2-24: The Measurement Sequence dialog box (if operating country is United States) .....	2-26
Figure 2-25: The Measurement Sequence dialog box (if operating country is not United States) .....	2-27
Figure 2-26: The Measurement Sequence dialog box after measurements are selected .....	2-28
Figure 2-27: The Edit Time Parameters dialog box .....	2-28

Figure 2–28: The dialog box that tells you that CSS500 is running a measurement sequence .....	2–29
Figure 2–29: Query dialog box .....	2–30
Figure 2–30: Measurement sequence results with view sequence filter on ...	2–30
Figure 2–31: The FCC Pre-Converter Measurements dialog box ...	2–32
Figure 2–32: Measurement Sequence dialog box after using an Auto Selection command button and adding additional measurements	2–34
Figure 2–33: The Print Setup dialog box .....	2–36
Figure 2–34: The Print dialog box .....	2–36
Figure 2–35: Selecting Demodulator from the Configure menu .....	2–39
Figure 2–36: The Demodulator Setups dialog box .....	2–40
Figure 2–37: The Connections dialog box .....	2–41
Figure 2–38: The Measurement Setups dialog box .....	2–42
Figure 2–39: The Edit Setups dialog box for channel 2 (NTSC) .....	2–45
Figure 2–40: The Edit Setups dialog box for channel 2 (PAL) .....	2–46
Figure 2–41: The Get Defaults dialog box .....	2–48
Figure 2–42: The Worksheet Info dialog box used to change the Channel Table .....	2–50
Figure 2–43: Warning message that the worksheet has changed ....	2–51
Figure 2–44: The Preferences dialog box .....	2–52
Figure 2–45: A three-dimensional view of a spreadsheet. ....	2–53
Figure 2–46: The effect of turning Collect History off and then on ..	2–53
Figure 2–47: Prompt to connect the input signal to the 2714/2715 ...	2–56
Figure 2–48: Message box stating that the measurements are paused.	2–56
Figure 2–49: The message box displayed when a measurement result falls into an Alarm range .....	2–57
Figure 2–50: Message box stating that the measurement is paused ..	2–57
Figure 2–51: The Results Detail dialog box for the HUM/LFD measurement	2–64
Figure 2–52: The Results Detail dialog box for the FCC Baseband measurement for the first channel .....	2–61
Figure 2–53: The worksheet after making all of the measurements for the first three channels .....	2–63
Figure 2–54: The Status Report dialog box .....	2–63
Figure 2–55: The View Violations display .....	2–64
Figure 2–56: The Results Detail display .....	2–65
Figure 2–57: The Copy dialog box .....	2–67
Figure 2–58: The results of pasting the Clipboard data into Excel ..	2–68
Figure 2–59: The Copy dialog box .....	2–69

Figure 2-60: The result of the Copy As Displayed pasted into Excel .	2-70
Figure 2-61: Data for the Carrier to Noise Ratio for four channels .	2-71
Figure 2-62: The Export dialog box .....	2-72
Figure 2-63: Measurements and Channels View Filter dialog box ..	2-74
Figure 2-64: The Measurement and Channels dialog box .....	2-75
Figure 2-65: The Spreadsheet with the Measurement and Channels View Filter on .....	2-76
Figure 2-66: The prompt to turn on the Measurement Sequence Results filter given at the end of a Measurement Sequence .....	2-77
Figure 2-67: The spreadsheet with the Measurement Sequence Results filter turned on .....	2-78
Figure 2-68: The results of turning on the Test ID Results filter ....	2-79
Figure 2-69: The Measurement Limits dialog box .....	2-80
Figure 2-70: The Edit Limits File – ntsc.lim dialog box .....	2-81
Figure 2-71: How limits work .....	2-82
Figure 2-72: An example of an error message .....	2-82
Figure 2-73: The Summary Limits (located at the bottom of the Limits dialog box) .....	2-85
Figure 2-74: The Parameters dialog box .....	2-85
Figure 2-75: Worksheet header after being edited for the UDP ....	2-87
Figure 2-76: The Create 2714/2715 UDP dialog box .....	2-88
Figure 2-77: The Get Stored Results dialog box. ....	2-90
Figure 2-78: The Export dialog box .....	2-90
Figure 2-79: The Get Stored Results dialog box after the selected site results have been exported to a results file .....	2-91
Figure 2-80: A warning that the site name does not match the current site name in the worksheet .....	2-91
Figure 2-81: Warning that the current site name does not match the imported site name .....	2-92
Figure 2-82: Warning that the 271X and worksheet Channel Tables do not match .....	2-92
Figure 2-83: The Import Results dialog box .....	2-93
Figure 2-84: Message box that tells you that the import procedure is finished .....	2-94
Figure 3-1: Parts of the CSS500 worksheet .....	3-3
Figure 3-2: The worksheet header .....	3-4
Figure 3-3: The Control menu box .....	3-9
Figure 3-4: The File menu .....	3-11
Figure 3-5: The New dialog box .....	3-12

Figure 3–6: The Open dialog box .....	3–13
Figure 3–7: The Save As dialog box .....	3–14
Figure 3–8: The Import dialog box .....	3–15
Figure 3–9: The Export dialog box .....	3–16
Figure 3–10: The Print dialog box .....	3–17
Figure 3–11: The Print Setup dialog box .....	3–22
Figure 3–12: The Edit menu .....	3–23
Figure 3–13: The Copy dialog box .....	3–23
Figure 3–14: The Clear dialog box .....	3–25
Figure 3–15: The View menu .....	3–26
Figure 3–16: The Status Report .....	3–27
Figure 3–17: View Violations dialog box .....	3–31
Figure 3–18: Results Detail dialog box .....	3–32
Figure 3–19: The 24 hour Carrier Summary display .....	3–36
Figure 3–20: Example of a Channel Summary .....	3–37
Figure 3–21: Example of a Measurement Summary .....	3–38
Figure 3–22: Global View dialog box .....	3–39
Figure 3–23: The Measurements and Channels dialog box .....	3–41
Figure 3–24: Worksheet with Measurements and Channel View Filter on ... 3–42	
Figure 3–25: Warning message .....	3–43
Figure 3–26: The Row Header Fields dialog box .....	3–44
Figure 3–27: The Measure menu .....	3–45
Figure 3–28: The Get Stored Results dialog box .....	3–47
Figure 3–29: The Import Results dialog box .....	3–48
Figure 3–30: Imported results messages .....	3–49
Figure 3–31: The Configure menu .....	3–49
Figure 3–32: The Worksheet Info dialog box .....	3–50
Figure 3–33: The Test ID dialog box .....	3–52
Figure 3–34: The Preferences dialog box .....	3–53
Figure 3–35: How measurements are saved when history is turned off, then on .....	3–53
Figure 3–36: Measurement Sequence dialog box .....	3–57
Figure 3–37: Edit Time Parameters dialog box .....	3–59
Figure 3–38: Generate 2714/2715 UDP dialog box .....	3–60
Figure 3–39: A non-US Measurement Sequence dialog box .....	3–64
Figure 3–40: The Measurement Limits dialog box .....	3–65
Figure 3–41: The Edit Limits File dialog box .....	3–66
Figure 3–42: How the upper and lower limits work .....	3–67

Figure 3-43: The Save As Defaults dialog box .....	3-68
Figure 3-44: Summary Limits (part of the Measurement Limits dialog box) 3-69	
Figure 3-45: The Parameters dialog box .....	3-70
Figure 3-46: The Measurement Setups dialog box .....	3-71
Figure 3-47: The Edit Setups dialog box .....	3-73
Figure 3-48: CTB/CSO measurement results distribution and the CSO setup restrictions .....	3-76
Figure 3-49: The VITS group for a PAL system .....	3-77
Figure 3-50: The Edit PAL VITS dialog box .....	3-79
Figure 3-51: Get Defaults dialog box .....	3-80
Figure 3-52: Save As Defaults dialog box .....	3-80
Figure 3-53: Copy to All Channels dialog box .....	3-81
Figure 3-54: The Connections dialog box .....	3-82
Figure 3-55: The Demodulator menu item .....	3-83
Figure 3-56: The Demodulator Setups dialog box .....	3-83
Figure 3-57: The Help menu .....	3-84
Figure 3-58: The Help Contents dialog box .....	3-85
Figure 3-59: The About dialog box .....	3-86
Figure C-1: The main window of the Channel Table Editor .....	C-2
Figure C-2: The Edit Table Information dialog box .....	C-3
Figure C-3: The test1.cht Channel Table before beginning the edits .	C-4
Figure C-4: The Channel Table Editor with one channel's data entered .... C-4	
Figure C-5: Warning that you have made changes and not saved them .....	C-5
Figure C-6: The Open dialog box .....	C-5
Figure C-7: The std.cht Channel Table (with all fields shown) .....	C-6
Figure C-8: The Save As dialog box .....	C-7
Figure C-9: The Copy Fields to End dialog box .....	C-8
Figure C-10: The To dialog box .....	C-9
Figure C-11: The Control Box menu .....	C-14
Figure C-12: The Menu Bar .....	C-15
Figure C-13: The File menu .....	C-15
Figure C-14: The Open dialog box .....	C-16
Figure C-15: The Save As dialog box .....	C-16
Figure C-16: The Print dialog box .....	C-17
Figure C-17: The Print Setup dialog box .....	C-17

<b>Figure C-18: The Edit menu</b> .....	<b>C-18</b>
<b>Figure C-19: The Copy Fields to End dialog box</b> .....	<b>C-18</b>
<b>Figure C-20: The Edit Table Information dialog box</b> .....	<b>C-19</b>
<b>Figure C-21: The View Channel Table Fields dialog box</b> .....	<b>C-20</b>
<b>Figure C-22: The Transfer menu</b> .....	<b>C-22</b>
<b>Figure C-23: The To dialog box</b> .....	<b>C-22</b>
<b>Figure C-24: The From dialog box</b> .....	<b>C-23</b>
<b>Figure C-25: The From (Select Table) dialog box</b> .....	<b>C-23</b>
<b>Figure C-26: The Delete dialog box</b> .....	<b>C-23</b>
<b>Figure C-27: The Delete (Select Table) dialog box</b> .....	<b>C-24</b>
<b>Figure C-28: The Select dialog box</b> .....	<b>C-24</b>
<b>Figure C-29: The Limit Check dialog box</b> .....	<b>C-25</b>
<b>Figure C-30: The Message box warning that multiple channel widths are incompatible with some 2714 and 2715 instruments</b> .....	<b>C-25</b>
<b>Figure C-31: Limit Check passed message</b> .....	<b>C-26</b>
<b>Figure C-32: The Connections dialog box</b> .....	<b>C-27</b>
<b>Figure C-33: The Channel Table Editor About dialog box</b> .....	<b>C-28</b>
<b>Figure C-34: The Global View from the CSS500 application</b> .....	<b>C-31</b>
<b>Figure D-1: Organization of files for logical record keeping</b> .....	<b>D-2</b>
<b>Figure F-1: Wiring diagram for CMP500</b> .....	<b>F-2</b>
<b>Figure F-2: Wiring diagram using the TV1350 instead of the TDC-10 and 1450A</b> .....	<b>F-3</b>
<b>Figure F-3: Using the EMFP</b> .....	<b>F-4</b>
<b>Figure F-4: Using a switcher</b> .....	<b>F-5</b>



## List of Tables

Table 1-1: Files contained in CSS500 directory .....	1-3
Table 1-2: Equipment required to make the various measurements	1-4
Table 1-3: GPIB board settings .....	1-6
Table 1-4: 271X (Option 03) GPIB .....	1-6
Table 1-5: 271X (Option 08) RS232 .....	1-6
Table 1-6: VM700A GPIB configuration .....	1-7
Table 1-7: TDC-10 settings .....	1-7
Table 1-8: 1405A front panel settings .....	1-7
Table 2-1: Measurements executed by Auto Selection buttons .....	2-31
Table 3-1: The measurements under each measurement header ...	3-18
Table 3-2: The results of copying one cell with history into Word for Windows .....	3-24
Table 3-3: The results of copying one cell using the As Displayed format ... 3-25	3-25
Table 3-4: The Measurement summaries in the status report .....	3-27
Table 3-5: Explanation of the Notes Field notes .....	3-34
Table 3-6: Auto Configure buttons .....	3-58
Table 3-7: Information loaded into the 271X during the creation of an UDP 3-61	3-61
Table 3-8: Measurements that require operator input .....	3-62
Table 3-9: Modes for unattended UDPs .....	3-63
Table 3-10: Required test signal for each measurement .....	3-77
Table A-1: CSS500 Menu Bar menu map .....	A-1
Table B-1: Error messages .....	B-1
Table B-2: Warning Messages .....	B-9
Table B-3: Informational Messages .....	B-10
Table C-1: Channel Tables provided with CSS500 .....	C-13
Table C-2: The Channel Table fields available from each group ...	C-21
Table D-1: How the results are exported from the 2714/2715 .....	D-11
Table E-1: CSS500 files and their approximate sizes .....	E-1
Table E-2: Types of files associated with CSS500 and their naming conventions .....	E-2
Table E-3: Help topics and their associated files .....	E-3
Table E-4: Contents of the CSS500.INI file .....	E-6
Table F-1: Equipment required for the measurement .....	F-1
Table G-1: Settings for Windows Terminal program .....	G-1

<b>Table G-2: Settings for local modem</b> .....	<b>G-2</b>
<b>Table G-3: Settings for remote modem</b> .....	<b>G-2</b>
<b>Table G-4: Settings for the 271X</b> .....	<b>G-3</b>

# Preface

The CSS500 System Software is Microsoft Windows-based software to control and display measurement results of the Cable TV CMP500 test equipment (VM700A, TDC-10, 1450A, 2714, 2715, TV1350, Rohde & Schwarz EMFP, and switcher). The point and click user interface makes operation easy, even for the inexperienced user. Making a measurement is as simple as selecting a channel and measurement type and clicking a mouse. In addition, the package can automatically monitor all in-service baseband and RF measurements and signal an alarm when a measurement exceeds a specified limit.

Measurement results are displayed in a table of channel vs. measurement type. For any measurement on a particular channel, the user simply clicks the mouse on that data cell, and a window appears with more information.

As with other Windows-based software, CSS500 data is exportable to other Windows-based software, such as Microsoft Excel, for in-depth data analysis.

## Customer Support

If you have any problems using this product, please call the Tektronix help line at:

1-800-TEKWIDE (1-800-835-9433)

## What's in this Manual

This manual assumes that you are familiar with Windows 3.1. Please refer to the Windows tutorial in the Windows reference manual for more information if you are not comfortable with Windows.

This manual is organized as three primary sections and a set of appendices. The three primary chapters and their contents are:

- Getting Started—which consists of a chapter on installing the software.
- Operating Basics—a tutorial for the beginning user.
- Reference—which contains several chapters that provide detailed information about the software. The chapters describe the CSS500 worksheet, the menu bar and menus, and provide advanced information on setups and measurements.

The contents of the appendices are:

- A Menu Map to give you a quick overview of the CSS500 software.
- A listing of error messages.
- An explanation of how to use the Channel Table Editor.
- Guidelines for using the CSS500 application to meet FCC measurement requirements for monitoring a cable system.
- Information about the CSS500 files (how to archive worksheets, file sizes, and other information).
- A wiring diagram to connect the test instruments to each other and to the controlling PC.
- An explanation of how to control a 2714/2715 over a modem.



# Getting Started

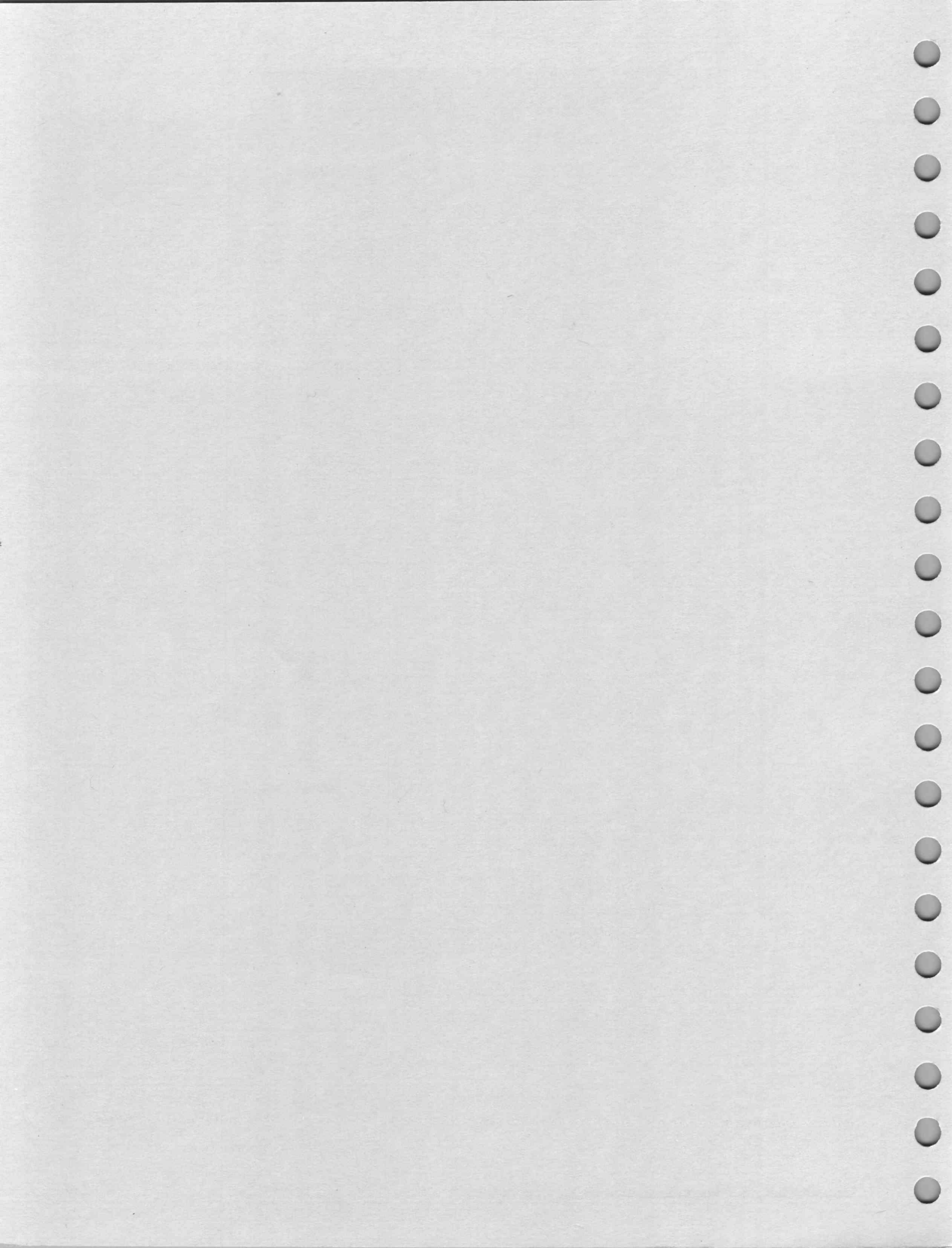

# Installation

This chapter describes how to install the CSS500 Cable Television Systems software.

## Contents of CSS500 Package

- One 3½ inch diskette, Tektronix part number 063-1587-02
- This manual, part number 070-8806-03

## Hardware Requirements

Minimum computer requirements for CSS500 to operate properly:

- MS-DOS compatible 16 MHz 386 personal computer with hard drive (486-33 is recommended)
- MS-DOS 5.0
- Microsoft Windows 3.1

---

**NOTE.** *Microsoft Windows NT is not recommended.*

---

- VGA display
- Video Display board for View Picture Mode – Optional (Video Blaster® recommended)
- 2 MB of RAM (8 MB recommended)
- 4 MB of free space on the hard drive
- GPIB or RS-232 interface. The GPIB hardware is assumed to be National Instruments GPIB-PCIIA with version 2.1.1 of the GPIB driver software. (Tektronix provides an appropriate GPIB board and driver software in the S3FG210 PC GPIB Package.) If using RS-232 ports, make sure that your computer has enough Com Ports.

---

**NOTE.** *If more than one GPIB board is installed, CSS500 must use board GPIB0.*

---

- Mouse or other pointing device is recommended but not required

## Software Installation

If you also have CSS150 installed on your computer, please see Appendix E for some special things to consider before installing CSS500.

### Step-by-Step Procedure to Install the CSS500 Software

1. Check the README.TXT file on the distribution diskette, for any additional information. This is important if you are upgrading from a previous version.

---

**NOTE.** *If you are upgrading from a previous version, do not put the new version in the same directory as the old version. This will make the installation go much faster and prevent overwriting any of your customizations. If you choose not to (or forget to) create a new directory, the install program questions you before it overwrites a file. At that point, you can choose not to overwrite any customized files.*

*When the installation is complete, you can move any of your custom files to the new directory. These files include: CSS500.INI, \*.HLP files (to the help sub-directory), \*.LIM files (to the limit sub-directory), and \*.CHT files.*

---

2. Create a directory on your hard drive where you want the CSS500 software installed.

For example, to create the directory "CSS500" on the C drive, type:

```
C:<enter>           (Puts you in the C drive.)
CD \<enter>        (Puts you at the root of the C drive.)
MKDIR CSS500<enter> (Creates the CSS500 directory.)
CD CSS500<enter>  (Changes to the CSS500 directory.)
```

3. Copy the files from the distribution diskette to the directory created in step 2.

For example, to copy the files from the B drive to C:\CSS500, insert the distribution diskette into the B drive and type:

```
XCOPY B:*. * <enter> (Copies everything from the B drive into the
                    current directory C:\CSS500.)
```

4. Install the CSS500 software.

From the directory created in step 2, run the INSTALL.BAT batch file by typing:

```
INSTALL.BAT <enter> (This batch file creates all the program files and
                    directories required for the CSS500 software.)
```

5. Create the Windows Program Group and Program Items.



Enter Windows, then follow the Windows Program Manager instructions to create a Program Group and Program Item for the CSS500 application (CSS500.EXE). Optionally, a Program Item for the Channel Table Editor (CTLOADE.EXE) can also be created.

---

**NOTE.** *If you are upgrading from a previous version, you should now move your custom files into the appropriate directory.*

---

6. After completing the installation, you can remove the INSTALL.BAT and SETUPCSS.EXE files to save disk space.

## Results of the Software Installation

The following lists the program items, directories, and files created as a result of the CSS500 installation.

<b>Windows Program Items</b>	CSS500.EXE (CSS500) CTLOADE.EXE (Channel Table Editor)
<b>Directories Created</b>	CSS500 (or whatever you chose to call it) <ul style="list-style-type: none"> <li>■ Sub-directories of CSS500:           <ul style="list-style-type: none"> <li>HELP</li> <li>LIMITS</li> </ul> </li> </ul>

### List of Files

**Table 1-1: Files contained in CSS500 directory**

INSTALL.BAT	EUR-BG.CHT	TBPRO1W.DLL
README.TXT	EUR-I.CHT	TBPRO2W.DLL
SETUPCSS.EXE	EUR_BG.CHT	TBPRO3W.DLL
EXPORTDB.EXE	EUR_I.CHT	TBPRO5W.DLL
CTLOADE.EXE	EUR_I1.CHT	TEKIO.DLL
CSS500.EXE	HRC.CHT	CTLOADD.DLL
B'CAST.CHT	IRC.CHT	MSMT.DLL
CATV-HRC.CHT	JAPAN-M.CHT	MSMTSTUB.DLL
CATV-IRC.CHT	JAPAN-M.CHT	MSMTREAL.DLL
CATV-STD.CHT	STD.CHT	RELEASE.LOG
CHINA-DK.CHT	STDOFST.CHT	CSS500.INI
CHIN_DK.CHT	STNDRD.CHT	CTLOADE.INI

**LIMITS Sub-Directory**    NTSC.LIM    PAL.LIM

---

**NOTE.** All Channel Table and Limits files provided with the CSS500 application are Read Only.

---

**HELP Sub-Directory**    All the help files are in this sub-directory. See Appendix E for how to edit these to fit your special requirements.

## Hardware Installation

**Minimum Equipment Installation**    Not all equipment must be installed to operate CSS500. If only some of the equipment is installed, use Table 1-2 to determine the available measurements.

**Table 1-2: Equipment required to make the various measurements**

Measurement	RF <sup>1</sup>	BB <sup>2</sup>
Visual Carrier Level	✓	
Visual Carrier Frequency	✓	
Aural Carrier Level	✓	
Aural Frequency Offset	✓	
Second Aural Level	✓	
Second Aural Frequency Offset	✓	
Average Power	✓	
Carrier to Noise	✓	
Desired to Undesired	✓	
CSO	✓	
CTB	✓	
Cross Modulation	✓	
In-Channel Response <sup>3</sup>	✓	✓
Adjacent Channel Leakage	✓	
Hum/LFD	✓	
FCC Baseband		✓
Modulation Depth <sup>3</sup>	✓	
Aural Deviation	✓	
Signal to Noise		✓

**Table 1–2: Equipment required to make the various measurements (Cont.)**

Measurement	RF <sup>1</sup>	BB <sup>2</sup>
Waveform Distortion		✓
Multiburst		✓
ICPM		✓
Audio		✓

<sup>1</sup> RF equipment includes the 271X.

<sup>2</sup> BB (Baseband) equipment includes: the VM700A, and the 1405A/TDC10 combination, the TV1350 Demodulator, or the Rohde & Schwarz EMFP. A switcher is optional.

If both columns are checked, use either RF or BB equipment to make the measurement.

## Test Equipment

The following test equipment is required to complete this installation:

- 271X Cable TV Spectrum Analyzer (271X can be either a 2714 or a 2715. If either instrument can be used, then 271X is called out. If something is instrument specific, then one or the other is called out.)
- If the 271X has option 08 installed, an RS-232 cable is required. The 25-pin RS-232 cable is Tektronix part number 012-1380-00. The 9-pin RS-232 cable is Tektronix part number is 012-1379-00.
- VM700A Video Measurement Set.
- 1450A Demodulator, a TV1350 Demodulator, or a Rohde & Schwarz EMFP.
- TDC-10 Tunable Down Converter (not required if using a TV1350 Demodulator or a Rohde & Schwarz EMFP).
- Three GPIB cables are needed to connect all the equipment to the PC (only 2 cables are needed if the 271X uses RS-232). The cables are Tektronix part number 012-0991-01 (for 1 meter length).
- A VITS Inserter. (This may be required if you are using a switcher.)
- An Audio Generator. (May be required to make audio measurements.)

Please see Appendix F for how the equipment should be connected for proper operation. (You can use just some of the equipment. See Table 1–2 for more information.) See the test equipment manuals for any additional hardware information.

CSS500 can only use one of each type of test equipment. For example, if you have two 271Xs in your system, CSS500 can only use one of them to make its measurements. Please specify the appropriate GPIB address of the particular 271X to be used.

## To Install the Equipment

Use the following procedures to install the equipment.

### GPIB Board

Note that CSS500 forces the GPIB board (GPIB0) to have an address of 30. Install the National GPIB hardware and Software for Windows using the instructions provided in National's manuals with the following settings:

**Table 1-3: GPIB board settings**

DMA Channel	NONE
IRQ	NONE

### 271X

The following lists how the 271X (both GPIB and RS-232 versions) should be configured.

**Table 1-4: 271X (Option 03) GPIB**

Status	ONLINE
GPIB Address	1 <sup>1</sup>
Power On SRQ	ON or OFF
EOI/LF Mode	LF/EOI
Talk Only Mode	OFF

<sup>1</sup> **This is restricted only in that it must be a unique address between 0 and 29**

**Table 1-5: 271X (Option 08) RS232**

Status	ONLINE
Baud Rate	9600 <sup>1</sup>
Data Bits	8
Parity	NONE
EOL	LF
Flow Control	HARD (RTS/CTS)

**Table 1–5: 271X (Option 08) RS232 (Cont.)**

Echo	OFF
Verbose	OFF

<sup>1</sup> **Device baud rate is selectable through the CSS500 Connections menu. Other communications parameters must be set to these values.**

**VM700A GPIB**

The following lists how the VM700A GPIB should be configured.

**Table 1–6: VM700A GPIB configuration**

Remote Control Port:	GPIB
GPIB Device Address:	2 <sup>1</sup>

<sup>1</sup> **This is restricted only in that it must be a unique address between 0 and 29**

**TDC-10**

The following lists how the TDC-10 should be set.

**Table 1–7: TDC-10 settings**

GPIB	Status	ONLINE
	Address	3 <sup>1</sup>
Other	Output IF	Must match that required by the 1450A

<sup>1</sup> **This is restricted only in that it must be a unique address between 0 and 29**

**1450A Front Panel Settings**

The 1450A is not under direct control of CSS500, but its Detection Mode is controlled by the TDC-10.

**Table 1–8: 1405A front panel settings**

Detection Mode	BACK PORCH
Synchronous Time Constant	NORMAL
Sound Trap	IN
Internal Zero Carrier Ref.	ON
10dB Attenuator	OUT
20dB Attenuator	OUT

**Table 1–8: 1405A front panel settings (Cont.)**

Auto	BACK PORCH
AGC Speed	FAST

The Zero Carrier Reference Pulse setting is controlled by a jumper within the 1450A. Refer to the 1450A manual for how to set this parameter.

**TV1350 Demodulator and Rohde & Schwarz EMFP Settings**

CSS500 controls the front panel settings. Therefore, no matter what the front panel on the instrument indicates, the actual control parameters are in the CSS500.INI file and set by the Demodulator Setup dialog box. See *Select the Correct Demodulator and Configure the Connections*, on page 1–8, for how to set the variables.

A jumper within the TV1350 controls the Zero Carrier Reference Pulse. Refer to the TV1350 manual for how to set this parameter.

**Switcher Settings**

The switcher settings must be appropriate for your switcher. Since many different switchers can operate with CSS500, please check your switcher documentation for the correct parameter values.

The Delay parameter is used whenever the delay flag is given in the Switcher String, /FF and at the end of the Switcher String. The delay is given in seconds. (Please see Appendix C for how to use the Switcher String.)

- Switcher Control Port
- Baud Rate
- Flow Control
- Parity
- Stop Bits
- Data Bits
- Delay

**Select the Correct Demodulator and Configure the Connections**

CSS500 must know which kind of demodulator is connected in your system. CSS500 will run with either a TDC-10/1450A combination, a TV1350, or an EMFP. The first time that you run CSS500 you need to check that CSS500 knows your equipment setup.

1. Start CSS500 by clicking on the icon (created during software installation) or run CSS500.EXE from the command line.
2. When the CSS500 start-up is complete, choose Demodulator from the Configure menu. The display will be similar to Figure 1-1. The checked demodulator is the one selected. Choose the correct one for your system.

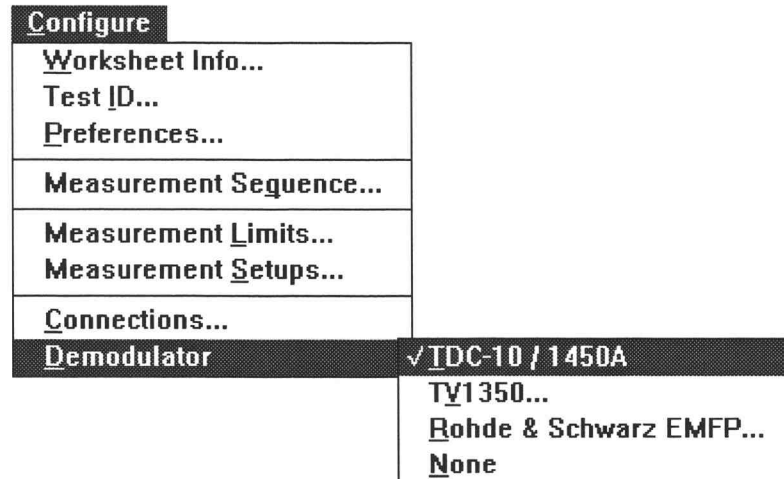

Figure 1-1: The Demodulator selection, from the Configure menu

3. If you select either the TV1350 or the EMFP, you are presented with an additional dialog box, shown in Figure 1-2.

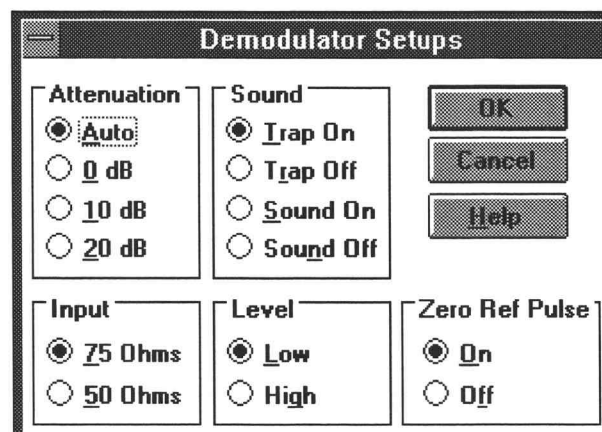
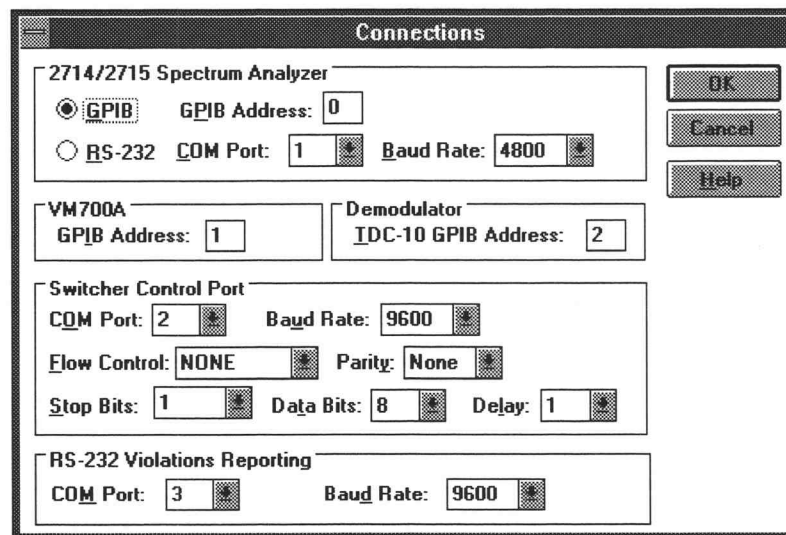

Figure 1-2: The Demodulator Setups dialog box

4. Set the demodulator parameters as required for your equipment configuration. If the TV1350 is being used in a non-system M setup, you must use SAW. See the TV1350 documentation for more information.

Now set the communication parameters for each piece of test equipment.

5. Choose Connections from the Configure menu. The Connections dialog box looks similar to the one shown in Figure 1–3 (if TDC-10/1450A is selected as the demodulator). Each demodulator causes a slightly different Demodulator Group to be displayed in the Connections dialog box.



**Figure 1–3: The Connections dialog box when TDC-10/1450A is selected as the demodulator**

6. Enter the GPIB addresses for the VM700A, the Demodulator, and the 271X. The allowable addresses are 0 – 29.
7. If the 271X has an RS-232 connection instead of a GPIB, it must be entered along with the baud rate and the correct Communications (Com) Port.
8. Set the Switcher Control Port and fields if applicable for your system.
9. Set the RS-232 Violations Reporting Com Port and Baud rate if you need to have errors reported for the RS-232 Port.
10. Select OK when the dialog box has been set up correctly.



## Upgrade From the MS-DOS Based Tektronix Cable TV Software

If you are not upgrading from the MS-DOS based Cable TV RF Measurements Software, skip to *Basic Tutorial* on page 2-1. If you are upgrading from the MS-DOS based Cable TV RF Measurements Software, you must run the `exportdb.exe` utility to transfer test results and channel tables from the MS-DOS based Cable TV RF Measurements Software to the MS-Windows-based CSS500 software.

### The Data Storage Structure

This utility is necessary because the DOS-based Cable TV Software stores its data differently than CSS500 does. The Cable TV Software stores all test results and all channel table data together in four related database files. The CSS500 software is oriented around worksheets (or spreadsheets). Each worksheet is based on a single channel table and site combination. While several worksheets may be based on the same channel table and site combination, a single worksheet may not use more than one channel table and site.

This utility will scan each of the two pairs of DOS-based database files and allow you to create data files and channel table files that are usable by the CSS500 software.

### Running the Utility

You should run the `exportdb` utility from the same directory in which your CSS500 software is installed (probably CSS500). The exported channel tables and data files will then be placed in that directory, which is also the default location where the CSS500 software looks for these files. To provide maximum protection for your existing data, please perform the following operations (from the DOS command line) to copy the four database files from the directory where your DOS-based Cable TV Software is located to the directory in which your CSS500 software is located. Then run `exportdb`.

```
CD C:\CSS500 (directory for the CSS500 software)
COPY C:\CATV\SARESLT.DBF (This assumes that the DOS-based )
COPY C:\CATV\SA_VALUE.DBF (CATV software is installed in the)
COPY C:\CATV\CH_TBL.DBF (C:\CATV directory. If installed )
COPY C:\CATV\CHANNELS.DBF (elsewhere, use that directory )
EXPORTDB (instead.)
```

Since the source databases may contain a large number of channel tables and test results, you may want to export test results only, channel tables only, or both. The utility asks if you want to export any channel tables and then asks if you want to export any measurement data. If you answer Y to both, then you will be prompted whenever a new channel table is available to be exported and whenever a new measurement data file is available to be exported. If you answer N to either, then all prompts concerning that category will be skipped and nothing in that category will be exported. For the categories you select, you can also skip exporting individual channel table or data files.

The exportdb utility then verifies the integrity of the database files. It can export from DOS-based Cable TV Software Version 1.1 and later.

Since there are usually test results from several sites that are based on the same channel table, the databases are sorted first by the channel table name and then by the test site.

When channel tables are exported and a new channel table name is encountered, you are told the channel table name and asked for the DOS file name to which you want it exported; the default extension is .CHT. You can then type a new name or press the ESC key to skip exporting the channel table.

As test results are exported, whenever the channel table name or the site name changes, a new measurement data export file may be created. You are given the channel table name and the site name on which the data is based and you are asked for the DOS file name to which you want it exported; the default extension is .WSR. You can then type a new name or press the ESC key to skip exporting all data based on this channel table name and site name.

When channel tables are exported, it is possible to have channel tables available for export that have no measurement data associated with them (in the DOS-based Cable TV software, you can create channel tables without taking any measurements based on them). It is also possible to have measurement data available based on channel tables that are not available for export (in the DOS-based Cable TV software, you can delete channel tables from the databases after measurements based on them have been stored).

For the exported channel tables to be used by the CSS500 software, no additional action is required; they will appear in the list of available channel tables. To use the exported data, first create a new worksheet based on the same channel table that the data was based on. Then do File Import with the CSS500 software and select the exported file you want to import and use.

You can import and use the exported data even if the channel table it is based on is not available for export. In order to successfully import that data, the new worksheet must be based on a channel table that contains the same channels as the ones the tests were done on, and these must be analog channels (the DOS-based Cable TV software does not support digital channels). For ease of analyzing the resultant worksheet, the channel Frequency, Program Name and Tag fields should also be the same.



# Operating Basics

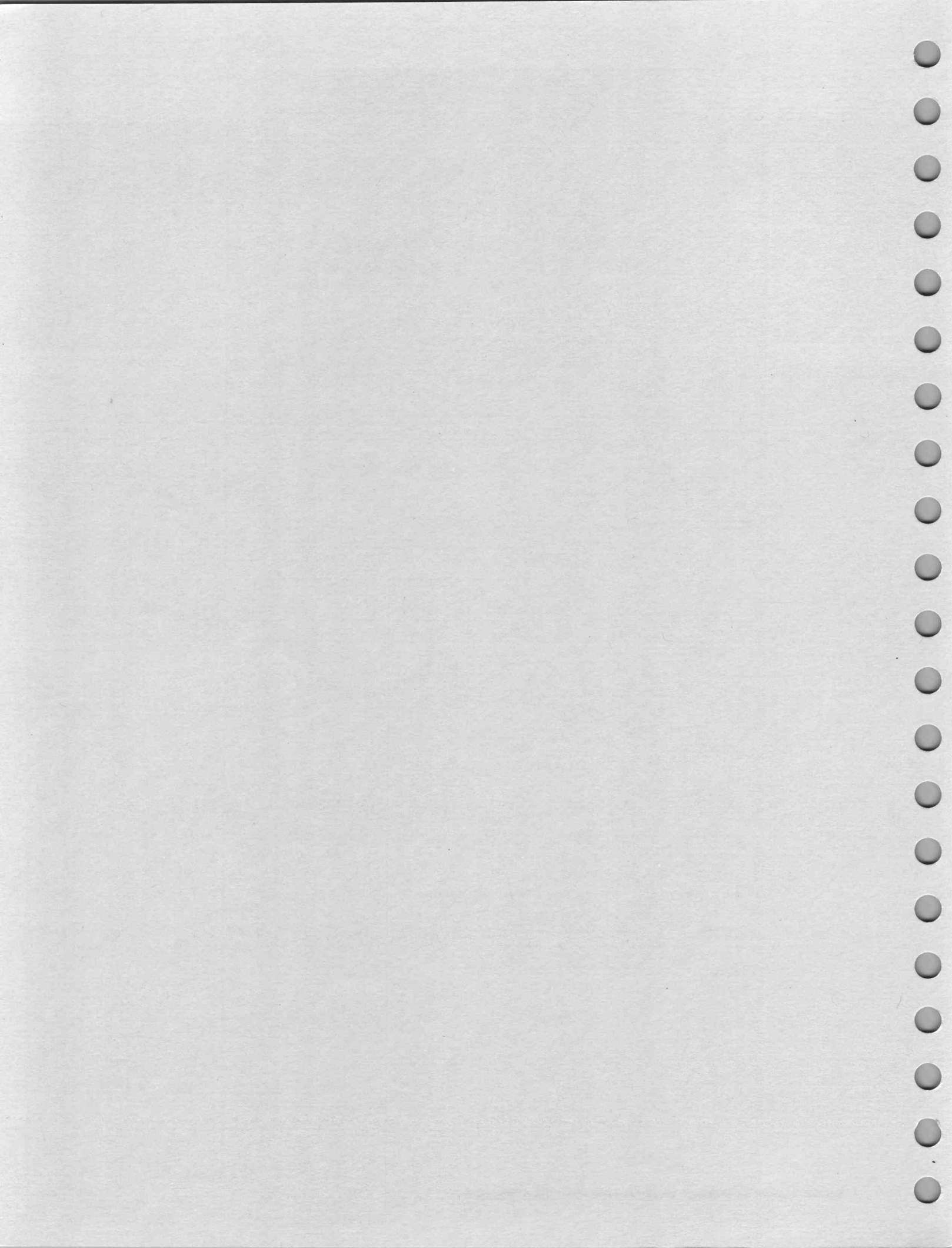

## Basic Tutorial

The goal of this chapter is to familiarize you with the basic layout of a worksheet, show you how to set up a worksheet, and make simple measurements.

Before beginning the tutorial, please check your hardware for the proper connections. (Appendix F gives cabling diagrams.) Double-checking the hardware will help prevent errors that are hardware related, and make learning how to use CSS500 that much easier.

If you want more information on an individual command, please refer to the on-line help or *Menu Bar*, which begins on page 3-11.

This tutorial assumes that a mouse is available. If a mouse is not available, make selections using ALT+the underlined letter of the command.

By the end of this chapter, you should be able to do the following:

- Select cells
- Enter Worksheet Header information
- Make simple measurements
- Enter the Global View
- Enter the Results Detail display
- Define a Measurement Sequence
- Execute a Measurement Sequence
- Define a Measurement Sequence using the Auto Selection buttons
- View the broadcast picture on the computer monitor
- Print out assorted reports

## What Can CSS500 Do?

The purpose of the CSS500 application is to make the time-consuming and tedious tasks of measuring and recording the results of measurements associated with a cable TV system. To make a measurement on a particular channel, simply select the cell where the channel and measurement intersect and double-click the left mouse button. The results are printed in the cell. Print out the reports and the job is completed. Of course, this is a cable system and there are many channels and many measurements. CSS500 allows you to make many measurements rapidly by selecting several channels or measurements.

## Start CSS500



1. Start the Windows program.
2. Find the icon for CSS500 (created during installation).

Mouse	Keyboard
Double click on the icon to start the application.	Enter the window with the CSS500 icon in it by pressing ALT+w, highlight the correct window, then press ENTER. Press the arrow keys to highlight the CSS500 icon, then press ENTER to start the application.

The initial display is called a worksheet. The worksheet will be blank except for the measurement list running across the top row and a channel list running down the left column.

## Description of the Worksheet

Figure 2–1 identifies the elements of the worksheet.

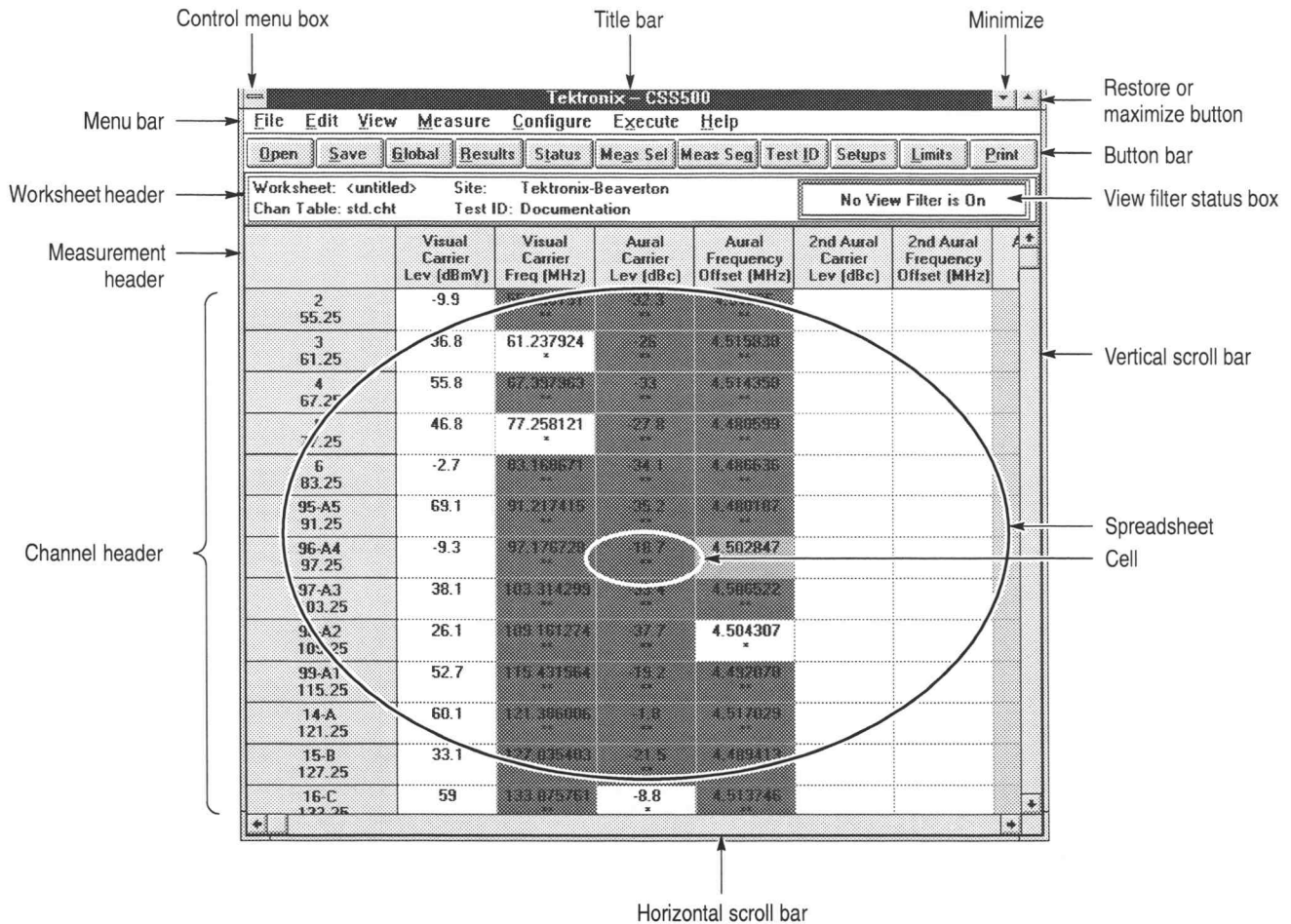

Figure 2–1: The default worksheet

### Elements of the Worksheet

The following paragraphs describe the various parts of the worksheet.

**Mouse Pointer.** (Not shown in figure.) The mouse pointer can take many shapes, dependent upon the functions available. If the pointer is a cross, it selects cells. If it is an arrow, it chooses commands. If it is an hourglass, the software is busy and no new actions are available.

**Title Bar.** This shows the name of the application, “Tektronix — CSS500”.



**Minimize Button.** Shrinks the application to an icon.



**Maximize Button.** Makes the application window fill the entire display area.



**Restore Button.** Returns the application window to its previous size.



**Control Menu Box.** Contains the standard Windows commands: Restore, Move, Size, Minimize, Maximize, Close, and Switch To.

**Channel Header.** Lists channels by number and center frequency.

**Measurement Header.** Lists measurements.

**Vertical Scroll Bar.** Moves the spreadsheet vertically. Note that the Measurement Header remains along the top as a reference.

**Horizontal Scroll Bar.** Moves the spreadsheet horizontally. Note that the Channel Header remains along the side as a reference.

**Menu Bar.** Provides access to the CSS500 menus.

**Button Bar.** Contains the command buttons. The command buttons are shortcuts with equivalents in the Menu Bar.

**Spreadsheet.** Contains all of the cells, the Measurement Header, and the Channel Headers.

**Cell.** One small box on the spreadsheet — the intersection of one measurement and one channel.

### Elements of the Worksheet Header

Figure 2–2 illustrates the Worksheet Header, which lists important information about a worksheet. You can edit this information in various ways depending upon which piece you would like to change. (See page 2–13 for how to set up a worksheet.)





**Figure 2-2: The Worksheet Header**

**Worksheet.** The name of the current worksheet. It is called <untitled> if the worksheet has not been saved.

**Chan Table.** This file lists the channels in the system under test. There must be a Channel Table or the CSS500 will not run.

**Site.** An additional identifier for the worksheet. Site is intended to be the location where the measurement takes place. Only one Site is allowed for each worksheet. <undefined> is a valid Site name.

**Test ID.** This is the name or ID of the person who is making the measurements, the measurement test point, or any other identifier that might be appropriate. A single worksheet can have multiple Test IDs. It sub-divides measurements made at a single Site (such as Pre-converter and Post-converter). <undefined> is a valid Test ID name.

**View Filter Box.** This tells how much of the spreadsheet is in view or available. The options for the box are: “No View Filter is On” (the entire spreadsheet is in view); “View Selected Filter is On” (display only selected measurements and channels); “View Sequence Filter is On” (display only measurements made with a Measurement Sequence); and “View Test ID Filter is On” (display only measurements made with the current Test ID). Note that only channels that are displayed are available for measurements.

## Navigation

This section explains how to get around in the CSS500 software. All actions are first explained for the mouse and then for the keyboard. If you are familiar with Windows command selection, skip to *Scroll Through the Spreadsheet* on page 2-9.

**Choose from the Menu Bar**

Step	Mouse	Keyboard
1	Single-click the left mouse button on the desired menu from the Menu Bar.	Press ALT+the underlined letter in the menu.
2	Single-click the left mouse button on the desired command.	Press the underlined letter for the desired command or use the arrow key to scroll, then press Enter.

**Example: Open a Worksheet**

Step	Mouse	Keyboard
1	Single-click the left mouse button on the word "File" on the Menu Bar.	Press ALT+f.

This displays the drop-down File menu, as shown in Figure 2–3.

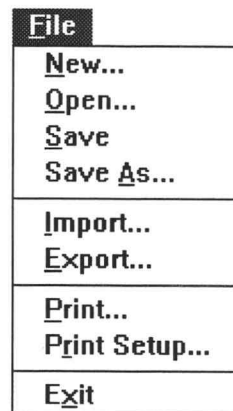

**Figure 2–3: The drop-down File menu**

Step	Mouse	Keyboard
2	Single-click the left mouse button on the word "Open".	Press o.

This displays the dialog box shown in Figure 2–4.

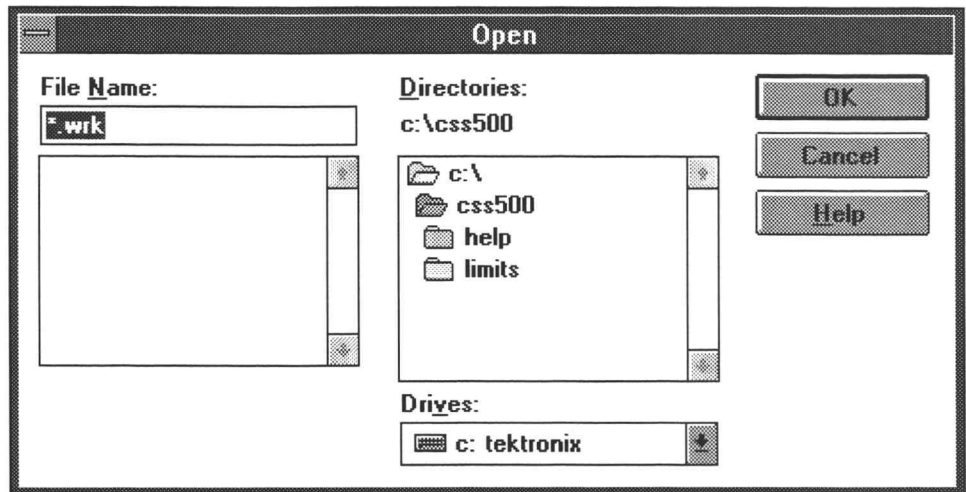

Figure 2-4: The Open dialog box

Step	Mouse	Keyboard
3	Single-click the left mouse button on the Cancel command button to close the Open dialog box without opening a file.	Press ESC to close the Open dialog box without opening a file.

**Choose from the Button Bar**

Mouse	Keyboard
Single-click the left mouse button on the desired command button.	Press ALT+the underlined letter from the command button.  or Press TAB to place the cursor on the Button Bar, then press either TAB or the arrow keys to select the command button. (Be careful using the arrow keys. They will scroll off the Button Bar and into the spreadsheet.) Press ENTER to choose the selected command button.

**Example: Open the Test ID Dialog Box**

Step	Mouse	Keyboard
1	Single-click the left mouse button on the Test ID command button.	Press ALT+i.

This displays the Test ID dialog box as shown in Figure 2–5.

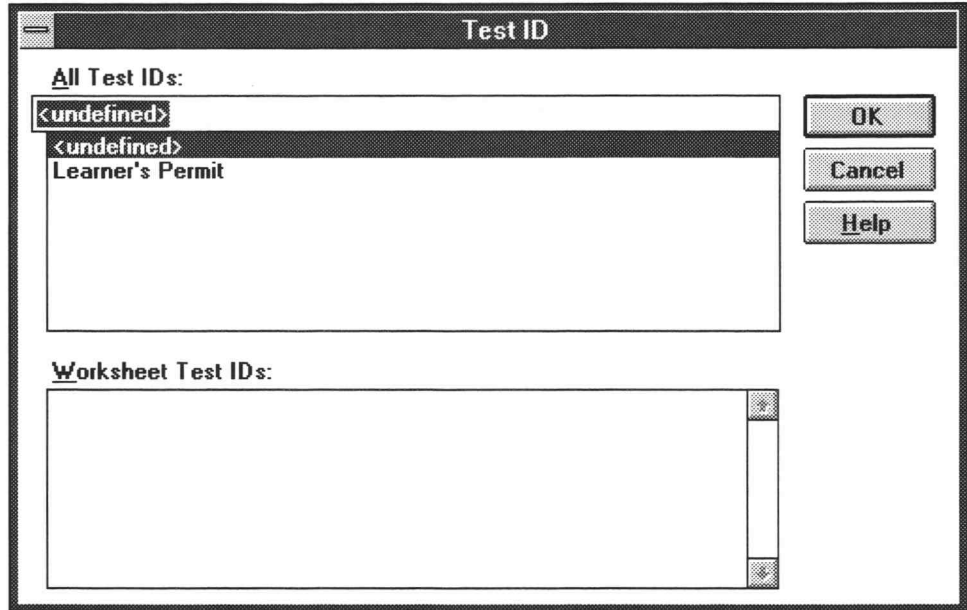

Figure 2–5: The Test ID dialog box

Step	Mouse	Keyboard
2	Single-click the left mouse button on the Cancel command button, to close the dialog box without making any changes.	Press ESC.

### Special Command Button Keyboard Shortcuts

Many dialog boxes have two special command buttons: OK and Cancel.

To choose OK from the keyboard, press ENTER with anything highlighted except the Cancel button.

To choose Cancel from the Keyboard, either press ESC or press TAB until the Cancel command button is highlighted, then press ENTER.

## Scroll Through the Spreadsheet

Mouse	Keyboard
<p>Either:</p> <p>Click on the left, right, up, or down scroll arrows in the Vertical or Horizontal Scroll Bar with the left mouse button. This moves the cursor one cell at a time.</p> <p>or</p> <p>Click on the scroll box in the Vertical or Horizontal Scroll Bar with the left mouse button, then hold down the left mouse button and drag the scroll box to the desired position. Release the mouse button.</p>	<p>Place the cursor in the spreadsheet. (Use the arrow keys if you are on the Button Bar or ESC if you are on the Menu Bar.) Use the arrow keys to scroll the spreadsheet to the desired position. The spreadsheet display will move every time you move to a cell that is off screen. The HOME, END, PAGE UP, and PAGE DOWN are also available to move quickly through the spreadsheet.</p> <p>HOME. Moves to the first cell in the current channel.</p> <p>END. Moves to the last cell in the current row that has a measurement made for any channel.</p> <p>PAGE UP. Moves the spreadsheet up one page. (Measurement stays the same and the current channel is the next channel that was just off screen to the top.) Nothing happens if the top channel is currently visible.</p> <p>PAGE DOWN. Moves the spreadsheet down one page. (Measurement stays the same and the current channel is the next channel that was just off screen to the bottom.) Nothing happens if the bottom channel is currently selected.</p>

### Example: Display the ICPM measurement for channel 3

Step	Mouse	Keyboard
1	Click on the Horizontal Scroll Bar box with the left mouse button. Hold down the left mouse button and drag the cursor until it is all the way to the right side of the Horizontal Scroll Bar. The ICPM column is visible.	Place the cursor on the spreadsheet. Press the right arrow key until the ICPM column is visible.
2	Click on the Vertical Scroll Bar's up arrow with the left mouse button until channel 3 (the second channel in the example) is visible. The spreadsheet looks similar to below. Notice the position of the boxes in the Vertical and Horizontal Scroll Bar.	Press the down arrow key until your second channel (channel 3 in the example) is visible. The spreadsheet looks similar to Figure 2-6. The ICPM cell for channel 3 is selected (using the std.cht Channel Table). Notice the position of the boxes in the Vertical and Horizontal Scroll Bar.
3	Reverse the steps to return to the spreadsheet to display the first column.	

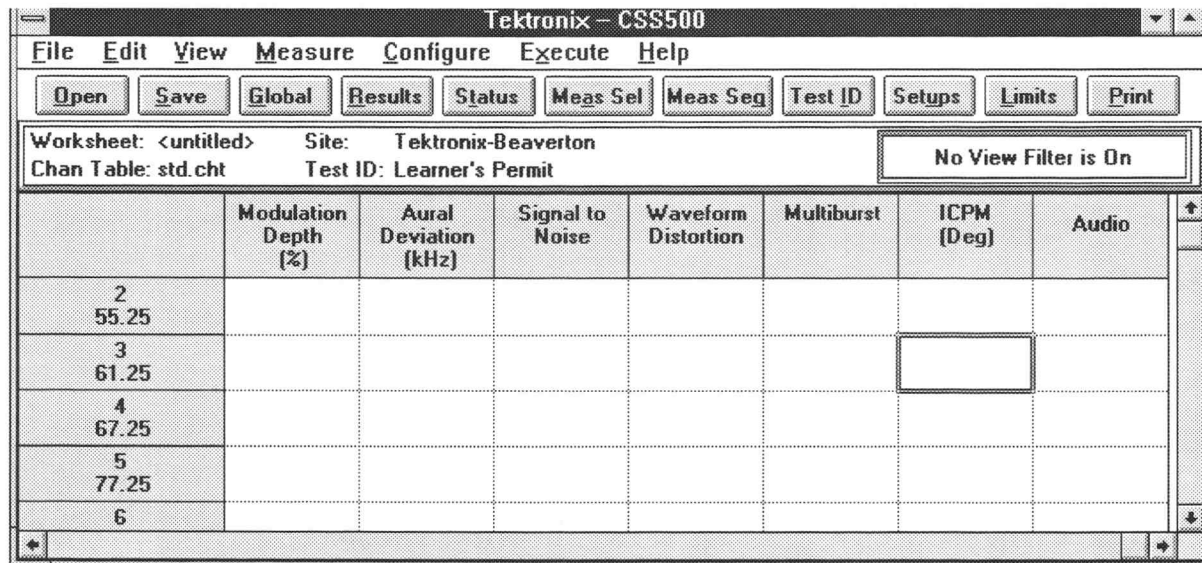

Figure 2-6: The spreadsheet scrolled to the ICPM column

**Select a Cell from the Spreadsheet**

Mouse	Keyboard
Single-click the left mouse button on the desired cell.	Press ESC or the arrow keys until the cursor is in the spreadsheet. Use the arrow keys to move the cell outline to the desired cell.

**Example: Select Carrier to Noise cell for channel 3**

Mouse	Keyboard
Place the mouse cursor anywhere in the cell. Single-click the left mouse button. The selected cell is outlined.	Use the arrow keys to move the cell outline to the desired cell.

The selected cell on the spreadsheet looks similar to Figure 2-7.

The screenshot shows the Tektronix CSS500 software interface. At the top is a menu bar with options: File, Edit, View, Measure, Configure, Execute, Help. Below the menu bar are several buttons: Open, Save, Global, Results, Status, Meas Sel, Meas Seg, Test ID, Setups, Limits, Print. The main area displays the following information:

- Worksheet: <untitled>
- Site: Tektronix-Beaverton
- Chan Table: std.cht
- Test ID: Learner's Permit
- No View Filter is On

Below this information is a spreadsheet with the following columns:

	2nd Aural Carrier Lev [dBc]	2nd Aural Frequency Offset [MHz]	Average Power [dBmV]	Carrier to Noise [dB]	Desired to Undesired [dB]	CSO [dBc]	CTB [dBc]
2 55.25							
3 61.25							
4 67.25							
5 77.25							
6							

The cell containing '3' and '61.25' is highlighted with a black border, indicating it is selected.

Figure 2-7: Example of a cell selected on the spreadsheet.

### Select a Group of Cells

Note that you can only select adjacent cells (rows, columns, or block). If non-adjacent cells need to be measured as a group, use a Measurement Sequence (see page 2-25).

Step	Mouse	Keyboard
1	Click on one of the corner cells in the desired group.	Press the arrow keys until one corner cell of the desired group is selected.
2	Hold down the left mouse button and drag the mouse until all of the desired cells have reversed color. (When the cell color reverses, it indicates selection. The first cell does not reverse color.)	Hold down the SHIFT button. Use the arrow keys to move around the spreadsheet until the desired group of cells has reversed color. (When a cell reverses color — it has been selected. The first cell does not reverse color.)
3	Release the left mouse button.	Release the SHIFT button.

**Example: Select channels 3-4's carrier levels and frequencies**

Step	Mouse	Keyboard
1	Single-click on the second channel's Visual Carrier Level cell.	Use the arrow keys to place the cursor around the second channel's Visual Carrier Level cell (Channel 3).
2	Start the mouse pointer in the selected cell, then hold down the left mouse button and drag the mouse cursor until the desired cells have reversed color. Release the left mouse button. The selected cells keep the reversed color, except for the original corner cell which is outlined.	Hold down the SHIFT key and use the arrow keys to select the desired cells. The selected cells reverse color, except for the original corner cell which is outlined.

The spreadsheet resembles Figure 2-8. Note that the selected cells have reversed in color except for the corner cell which is outlined.

	Visual Carrier Lev (dBmV)	Visual Carrier Freq (MHz)	Aural Carrier Lev (dBc)	Aural Frequency Offset (MHz)	2nd Aural Carrier Lev (dBc)	2nd Aural Frequency Offset (MHz)	Average Power (dBmV)
2 55.25							
3 61.25							
4 67.25							
5 77.25							
6							

Figure 2-8: A group of cells selected



**Selecting an Entire Row or Column**

Mouse	Keyboard
Single-click on the name of the measurement or channel in the Measurement or Channel Header.	To select an entire row, place the cursor anywhere in the row and press SHIFT+spacebar.  To select an entire column, place the cursor anywhere in the column and press CTRL+spacebar.

**Select the Entire Spreadsheet.** You can select the entire spreadsheet three ways:

**Select the Entire Spreadsheet**

Mouse	Keyboard
Click on the upper left cell (where the Channel and Measurement Headers intersect) with the left mouse button.	Press CTRL+SHIFT+spacebar.  Select the Edit menu by pressing ALT+E, then choose Select All by pressing S.

## Set Up a Worksheet

There are four parts to a worksheet definition: Site, Test ID, Channel Table, and Worksheet name. The Worksheet is the main file that stores everything. Each Worksheet may only have one Site and one Channel Table associated with it. If the Channel Table or Site changes, CSS500 automatically gives you the option to start a new worksheet or rename the Site in the current worksheet. You will now create a new worksheet for practice.

**Enter a Site and Description**

1. From the File menu, select New. If there was a worksheet already defined, the following Warning dialog box (Figure 2-9) may be displayed:

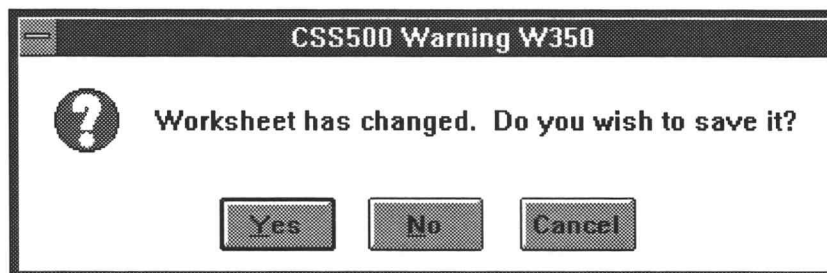

Figure 2-9: Warning dialog box

- Do not save the old worksheet — choose the No command button.

This displays the New dialog box, as shown in Figure 2–10.

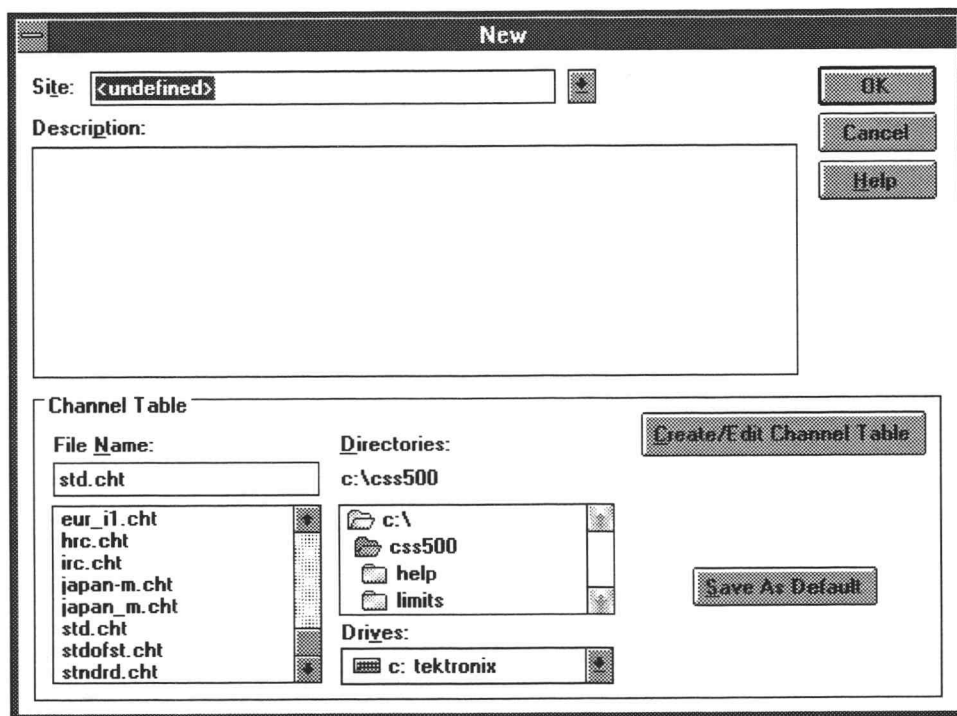

Figure 2–10: The New dialog box

- Select the Site combination box.

Mouse	Keyboard
Click on the Site combo box.	Press TAB until the cursor is blinking in the Site list box.

- Select a site name. (The example uses “Tektronix – Beaverton”.)

Mouse	Keyboard
Type in your site name or click on the arrow box to select a Site name from the combo box. (Use a site name appropriate to your setup.)	Type in your site name or press the up or down arrow keys to select a site name from the combo box.

5. Select the Description text box.

Mouse	Keyboard
Click the left button in the Description text box.	Press ALT+p or TAB.

6. Enter the description: "This worksheet is for practice only."
7. Select std.cht as the Channel Table by clicking on std.cht in the list box.
8. Leave the New dialog box and save the changes by choosing the OK command button.
9. From the File menu, choose Save As. The Save As dialog box appears, as shown in Figure 2-11.

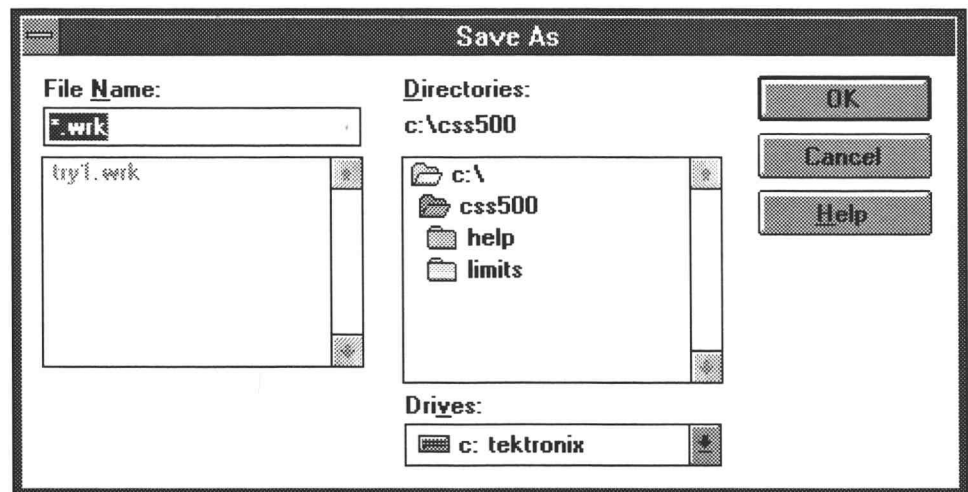

Figure 2-11: The Save As dialog box

10. In the File Name combo box, type: "example".
11. Choose the OK command button. The title "example.wrk" is in the worksheet header.

#### Enter a Test ID

1. From the Configure Menu, select Test ID or choose the Test ID command button from the Button Bar. This displays the Test ID dialog box, as shown in Figure 2-12.

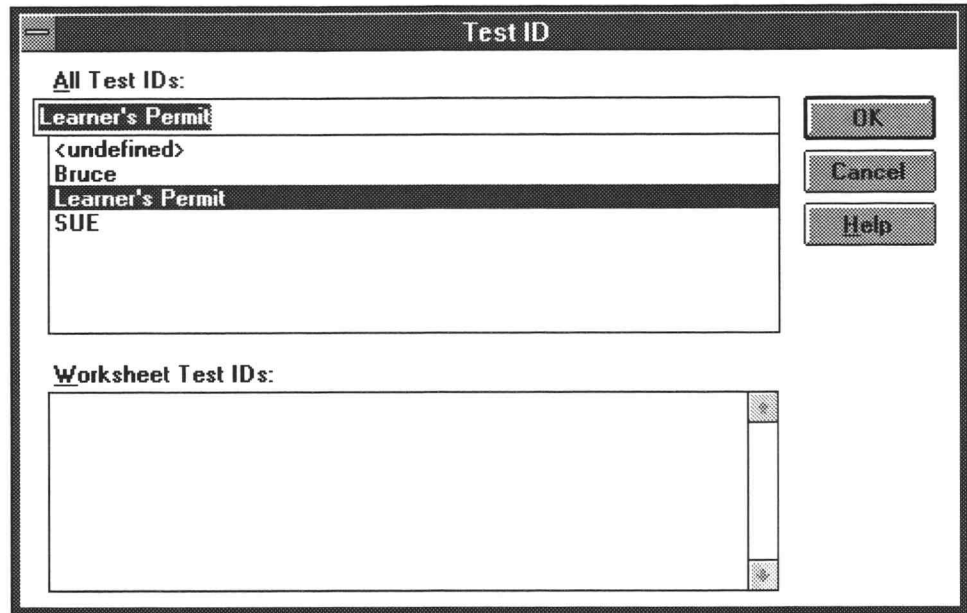

Figure 2–12: The initial display of the Test ID dialog box

2. Select a Test ID.

Mouse	Keyboard
Type in a Test ID or select from the combo box: click on the arrow in the list box (if present) and then select one from the list. The example uses "Learner's Permit".	Type in the Test ID or select one from the list box by scrolling through the list by pressing the down arrow key. The example uses "Learner's Permit".

3. Leave the Test ID dialog box and save the changes by choosing the OK command button.

The worksheet header should look similar to Figure 2–13.

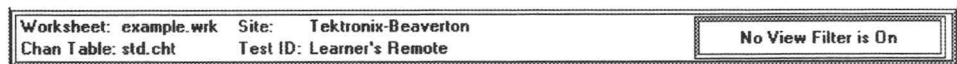

Figure 2–13: The worksheet header after filling in all information

### Attach/Change Channel Table

See *Advanced Setups Tutorial* on page 2–39 or *Appendix C: Channel Table Editor* if the Channel Table must be changed.

## Make Simple Measurements

You now have enough background to begin making simple measurements and you have created a new worksheet so you won't overwrite an existing one.

---

**NOTE.** Do not use the 2714 (and early 2715s) to take digital measurements. The 2714 will not run digital measurements (Average Power, Desired to Undesired, and Adjacent Channel Leakage), but uses the same channel table format as the 2715. If the software attempts to take a digital measurement using the 2714, measurements returned will be incorrect, errors will be returned, or the software will behave unpredictably.

---

### One Measurement for One Channel

To make one measurement on one channel, select a cell. From the Measure menu, choose Current Selection (or choose Meas Sel from the Button Bar) or double-click on a cell with the left mouse button.

The measurement results appear in the cell, replacing any previous results. (The previous results are not necessarily lost. See *Measurement History Group* on page 2–52.)

Only one measurement on one channel takes place, unless you select one of the first six measurements: Visual Carrier Level, Visual Carrier Frequency, Aural Carrier Level, Aural Frequency Offset, Second Aural Level, and Second Aural Frequency Offset. Select any of these cells and all six measurements are always taken.

#### Example: Measure Carrier Levels and Frequencies for the First Channel

Mouse	Keyboard
Select the cell by single-clicking the left mouse button.	Place the cursor in the spreadsheet, then use the arrow keys to select the cell.

Execute the measurement.

Mouse	Keyboard
Either double-click with the left mouse button, choose Current Selection from the Measure menu, or choose Meas Sel from the Button Bar.	Either choose Current Selection from the Measure menu or choose Meas Sel from the Button Bar.

A dialog box then appears, telling you that the software application is busy making measurements.

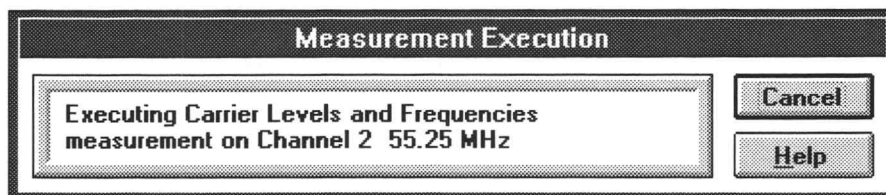
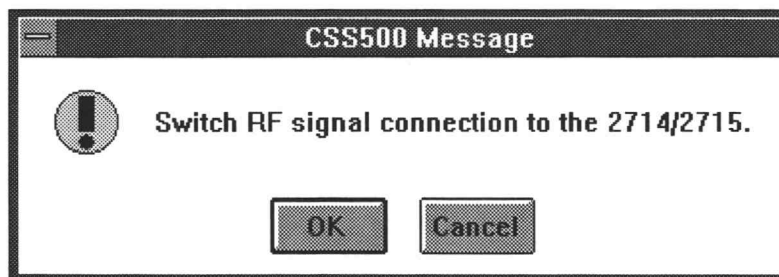

**Figure 2-14: Measurement Execution dialog box**

If you chose the wrong measurement or channel, choose the Cancel command button to stop the measurement. (Cancel stops after the current measurement, so it does nothing when making a single measurement.)

CSS500 might respond with a message to turn off the scrambling if that particular channel has scrambling enabled and the requested measurement requires it. (When all of the measurements for the channel are finished, then another message reminds you to turn the scrambling back on.)

CSS500 might also respond with the Message box shown in Figure 2-15.



**Figure 2-15: Message dialog box**

This is an optional dialog box warning you to double check your equipment setup. The measurement halts until you choose the OK command button. To stop the measurement choose the Cancel command button. (You can turn this message box on or off — see *Configuration Preferences*, page 2-51 .)

If everything is properly connected, select the OK command button.

CSS500 responds with the dialog box in Figure 2-16 to let you know that it is working on the measurement.

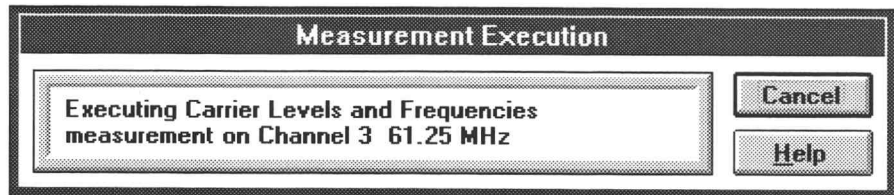

Figure 2-16: Measurement Execution Dialog box

Again, you can cancel the measurement at this point by choosing the Cancel command button.

CSS500 fills in the first four or six cells for the selected channel. (There are only four measurements made in the following example because std.cht does not have the Second Aural Frequency set. If this Channel Table has a value, then the last two measurements are available.)

Repeat this measurement for the next two channels on the list. The resulting spreadsheet looks similar to Figure 2-17.

Tektronix – CSS500										
File Edit View Measure Configure Execute Help										
Open	Save	Global	Results	Status	Meas Sel	Meas Seg	Test ID	Setups	Limits	Print
Worksheet: <untitled>		Site: Tektronix-Beaverton			View Sequence Filter is On					
Chan Table: std.cht		Test ID: test 43:16:35								
	Visual Carrier Lev (dBmV)	Visual Carrier Freq (MHz)	Aural Carrier Lev (dBc)	Aural Frequency Offset (MHz)	FCC Baseband	Multiburst				
2 55.25	21.8	55.49232 **	-27.7 **	4.495524 *	ALARM **	ALARM **				
4 67.25	-1.2	67.494462 **	-31.9 **	4.500718	ALARM **	ALARM **				
6 83.25	44.1	83.384962 **	-32.1 **	4.507761 **	ALARM **	ALARM **				

Figure 2-17: The spreadsheet after making a few measurements

### Make Several Measurements at a Time

To make several measurements: select the cells, then from the menu, choose Current Selection (or Meas Sel from the Button Bar). If you want to make all the measurements for a given channel, select that channel's row. Then from the Measure menu, choose Current Selection or double-click on the channel name in the Channel Header. This makes all the measurements on the selected channel.

Use the same procedure to run one measurement for all the channels: select all the channels for that measurement, then from the Measure menu, choose Current Selection or double-click on the Measurement Header.

Remember, you cannot use this method to make measurements on non-adjacent cells because they cannot be selected together. Use a Measurement Sequence (see page 2–25) to make measurements on non-adjacent cells.

Since it usually takes a little while for groups of measurements to complete, you can switch to other Windows applications while the measurements are executing.

**Example: Make FCC Baseband Measurements for Several Channels.**

1. Scroll the spreadsheet horizontally to display the FCC Baseband measurement column.
2. Select the first three channels for an FCC Baseband measurement. From the Measure menu, choose Current Selection. A dialog box similar to Figure 2–18 appears.

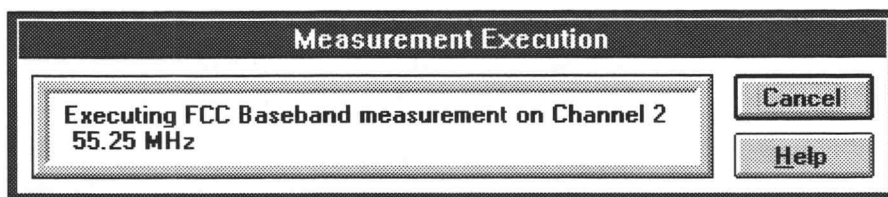

**Figure 2–18: Measurement Execution dialog box**

3. If you need to stop the measurement, choose the Cancel command button. This stops after completing the current measurement. (Pressing ESC, RETURN, or the spacebar will cancel the measurement.) Another dialog box might appear like that shown in Figure 2–19.

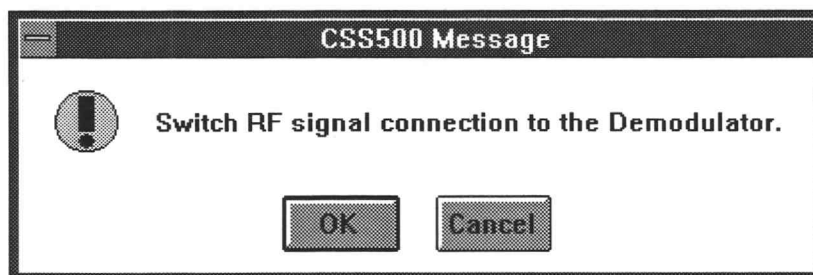

**Figure 2–19: RF Signal dialog box**



4. If the signal is connected to the Demodulator, choose the OK command button. If not, connect the signal, then choose the OK button. If the signal cannot be connected, choose the Cancel command button. The next dialog box tells you that a measurement is going to be made on the next channel (see Figure 2–20). This allows you to tune the external pre-selector, if necessary.

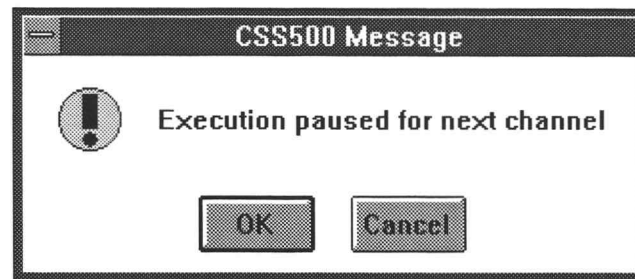

Figure 2–20: Execution dialog box

5. If you need to stop the measurement, choose the Cancel command box.

This dialog box repeats three times, once for each channel.

The spreadsheet cells should look similar to Figure 2–21.

FCC Baseband
PASS
PASS
PASS

Figure 2–21: The spreadsheet cells after making a group of measurements

Note that this measurement only gives Pass/Fail results instead of numerical results. There are several separate measurements under this Measurement Header and there isn't enough room to report all of the results in a single cell. The measurements under this measurement heading are: Differential Gain, Differential Phase, Chrominance-to-Luminance Gain, and Chrominance-to-Luminance Delay.

What if you want to see the individual results of each of these measurements? You enter the Results Detail display.

**Results Detail Display**

The Results Detail display gives more information than a single cell can hold. There are three ways to enter a cell's Results Detail display from the worksheet:

- Single click on the cell using the RIGHT mouse button.
- Select a cell, then choose the Results command button from the Button Bar.
- Select a cell, then from the View menu, choose Results Detail.

**Example: Results Detail for FCC Baseband for channel 2.**

1. Select channel 2's FCC Baseband measurement cell.
2. Choose the Results command button from the Button Bar. See Figure 2-22 for the dialog box.

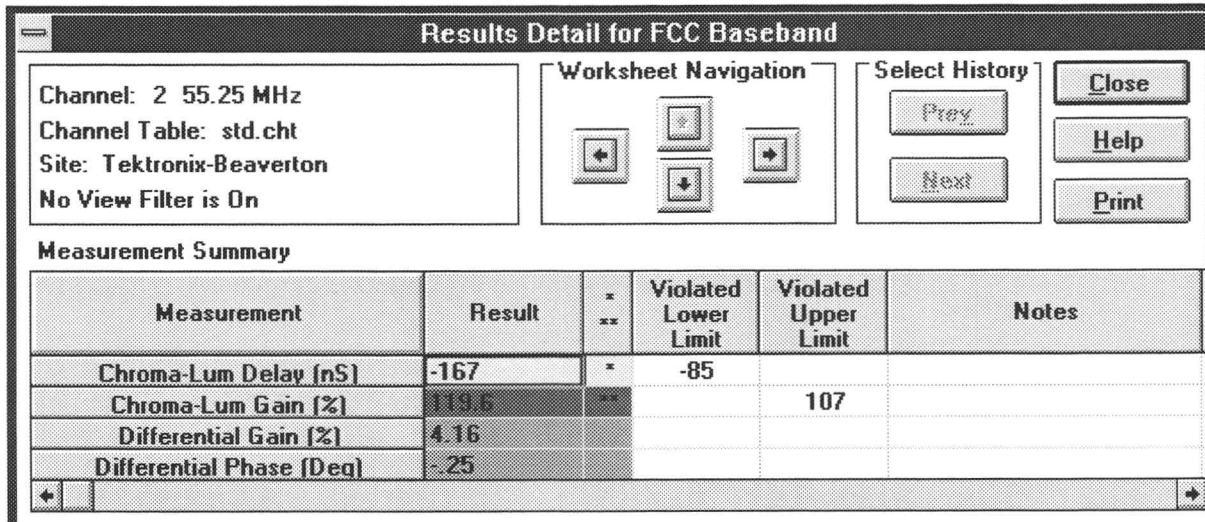

Figure 2-22: The Results Detail dialog box

3. Scroll to the right to view the Date & Time and the Test ID for these measurements. Choose the Close command button to return to the spreadsheet.

There is more information on this display under *Results Detail Display* on page 2-60.

**Cell Coloring**

You might have noticed that the cells have different colors. They are white, green, yellow, red, blue, or gray. These colors indicate the range of the measurement results. White means that there are no limits assigned to that measurement or no measurements have been made. Green means that the measurement is passing. Yellow means that the measurement is in the Caution range. Red means that the measurement has dropped into the Alarm state. The Limits File defines these ranges. Limits are covered in *Defining Limits*, page 2–79. Blue indicates that an error occurred in the measurement, making the results invalid. All of the results in the cell must be in error for the cell to be blue, otherwise the cell will take on the color of the worst case valid measurement. Gray cells have no measurement results. Any cell that is grayed is not included in the transfer to the RF instrument (that is, when the Channel Table is loaded into the instrument this channel is not loaded. Since the channel is not loaded, no RF measurements can be made on this channel). Therefore, they cannot have any RF results. Baseband measurements are still available for this channel. This value is set from the Channel Table Editor. (See Appendix C for more information on the Channel Table Editor.)

**Global View**

Another way of looking at the measurement results is the Global View. This display shows all of the measurements for many channels at a time. This view does not give numerical results, rather only pass, warning, alarm, unknown/not defined, or error-in-measurement indications based on the color of the cells.

Enter the Global View by choosing the Global command button on the Button Bar or, from the View menu, choose Global View.

The display should be similar to Figure 2–23.

	Vis Car Lev	Vis Car Freq	Aur Car Lev	Aur Car Freq	2nd Aur Lev	2nd Aur Freq	Avg Pwr	C / N	D / U	C S D	C T B	X Mod	A C L	I C R	H U M	FCC BB	Mod Dep	Aur Dev	S / N	Wfm Dis	
2																					
3		*																			
4																					
5																					
6																					
95																					
96																					
97																					
98																					
99																					
14																					
15																					
16																					
17																					
18																					
19																					
20																					
21																					
22																					
7																					
8																					

Figure 2-23: The Global View of the spreadsheet

The colors tell the health of the system and can give you a good overall feel of how the system is performing.

You can select a cell on this display and then go to the Results Detail display for that cell by choosing the View Results Detail command button. Also, by selecting the entire worksheet, you can go to the Status Report. If you select an entire row, you can go to the Channel Summary. If you select an entire column, you can go to the Measurement Summary.

Choose the Close command button to close the Global View and return to the spreadsheet.

## Define and Use a Measurement Sequence

Suppose you need to make several measurements on a couple of different channels on a regular basis. These measurements and channels are not close enough on the worksheet to select the cells and use Current Selection from the Measure menu. You do not have to do the measurements one cell at a time. Instead, you can use a Measurement Sequence. A Measurement Sequence is a list of measurements that you define and run whenever you need. You can only define one Measurement Sequence at a time, so there is no confusion about what measurements and channels are in a Measurement Sequence.

Now define a simple Measurement Sequence to make Carrier Level and Frequency, FCC Baseband, and Multiburst measurements for your first, third, and fifth channels.

### Define a Measurement Sequence

1. Clear the spreadsheet.
  - a. From the Edit menu, choose Select All.
  - b. From the Edit menu, choose Clear.
2. From the Configure menu, choose Measurement Sequence. The Measurement Sequence dialog box appears (see Figure 2-24 and Figure 2-25). Which Measurements Sequence dialog box appears depends on the country specified in the Windows Control Panel.

**Measurement Sequence**

Auto Selection

24 Hour Test
FCC Post-Converter

ECC Pre-Converter
FCC Headend Msmts

Edit Time Parameters
OK

Create 2714/2715 UDP

Cancel

Clear Sequence

Help

Carrier Survey

	Vis Car Lev	Vis Car Frg	Aur Car Lev	Aur Car Frg	2nd Aur Lev	2nd Aur Frg	Avg Pwr	C / N	D / U	C S Q	C T B	X Mod	A C L	I C R	H U M	FCC BB	Mod Dep	Aur Dev	S / N	W/m Dis	
2																					
3																					
4																					
5																					
6																					
95																					
96																					
97																					
98																					
99																					
14																					
15																					
16																					
17																					
18																					
19																					
20																					
21																					

Figure 2-24: The Measurement Sequence dialog box (if operating country is United States)

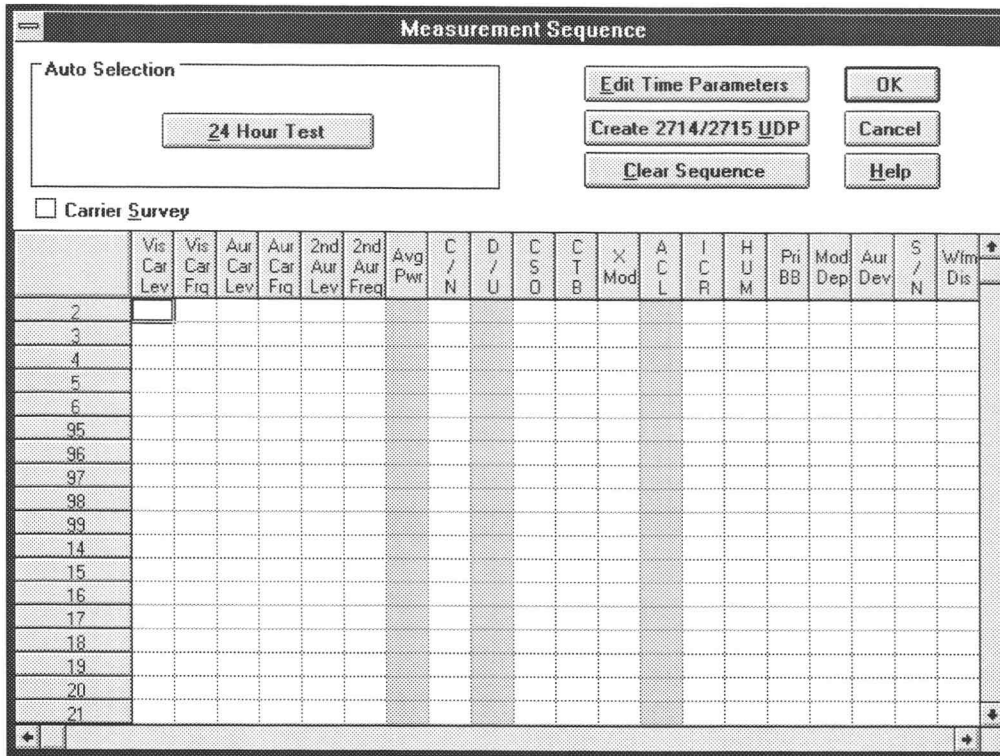

Figure 2–25: The Measurement Sequence dialog box (if operating country is not United States)

3. Select the Carrier Levels and Frequencies, FCC Baseband, and Multiburst for your first, third, and fifth channels.

Mouse	Keyboard
Double-click those cells. (To deselect: double-click on the cell again.)	Press TAB until the cursor is in the spreadsheet. Use the arrow keys to move to the cell, then select the cell by pressing the spacebar. (To deselect: press the spacebar again.)

Your dialog box should resemble Figure 2–26.

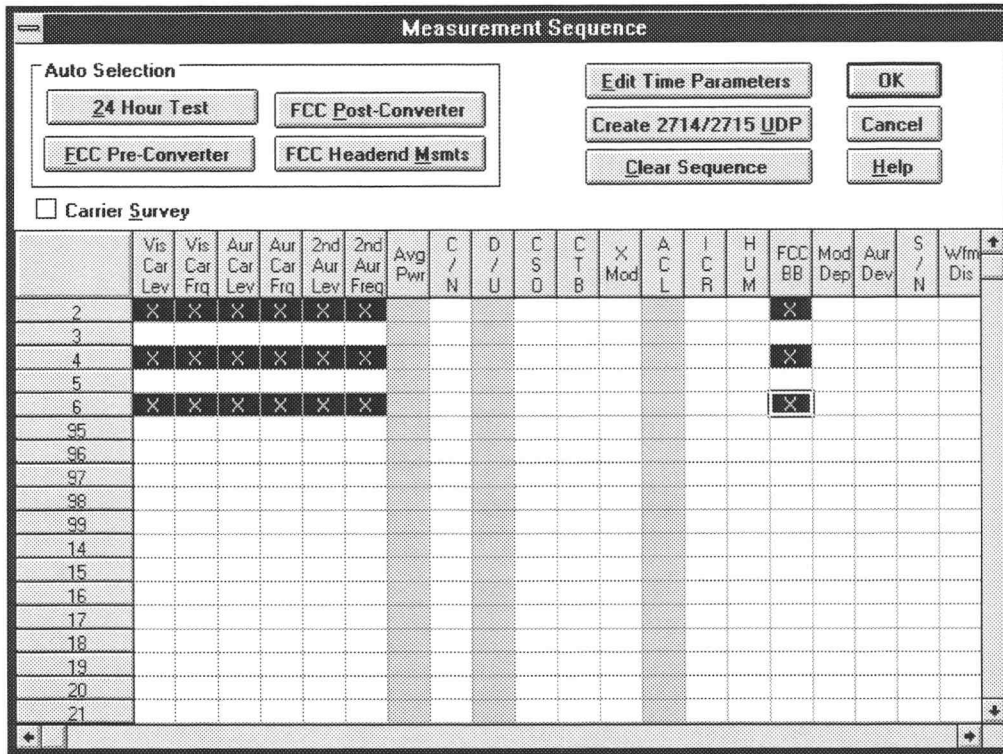

Figure 2-26: The Measurement Sequence dialog box after measurements are selected

4. Choose the Edit Time Parameters command button. The display should be similar to Figure 2-27.

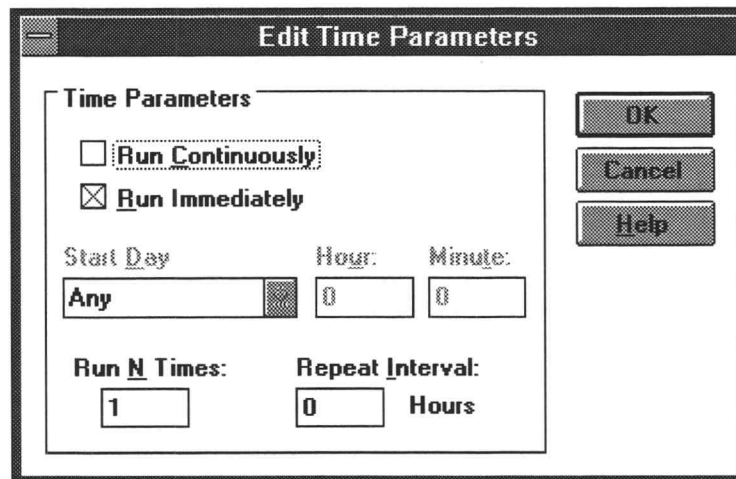

Figure 2-27: The Edit Time Parameters dialog box



5. Enter "1" in the Run N Times text box.
6. Enter "0" in the Repeat Interval text box.
7. The rest of the options in the Edit Time Parameters dialog box are gray, indicating they are not available. Choose the OK command button to save the changes and return to the Measurement Sequence dialog box.
8. Choose the OK command button to accept the Measurement Sequence. The display returns to the worksheet.

### Run the Measurement Sequence

1. Choose the Meas Seq command button from the Button Bar or from the Measure menu choose Measurement Sequence. The dialog box Figure 2–28 appears.

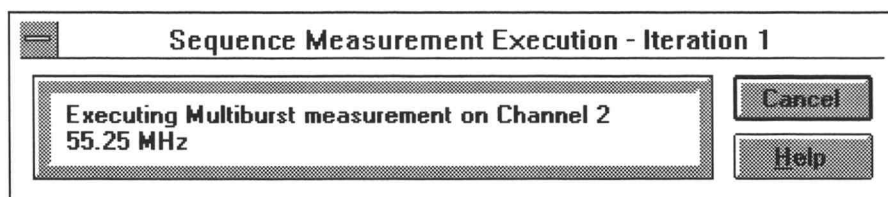

**Figure 2–28:** The dialog box that tells you that CSS500 is running a measurement sequence

2. If you want the Measurement Sequence to stop, choose the Cancel command button; otherwise allow the sequence to run. The Measurement Sequence runs through once. (It will take a while.)

---

**NOTE.** If you would like to change to another application while the Measurement Sequence is running, size the CSS500 window so the other application icons or windows are visible before starting the Measurement Sequence. Click on another icon or window to change applications. You can also use ALT+TAB to change applications. When the sequence is complete, CSS500 automatically becomes the active window.

---

At the end of the Measurement Sequence, the dialog box in Figure 2–29 appears.

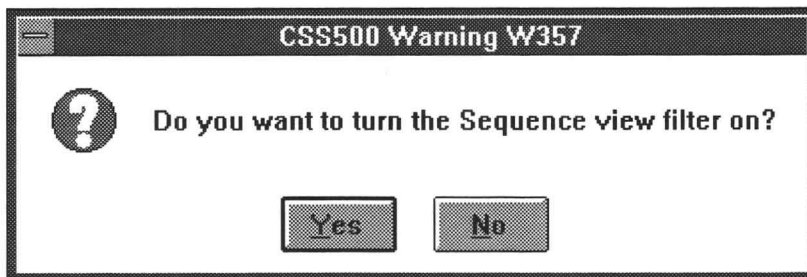

Figure 2-29: Query dialog box

- Choose the Yes command button. Now only the measurements made with the Measurement Sequence are visible and the View Filter box says that the Measurement Sequence View Filter is on (see Figure 2-30). For more information on View Filters, see page 2-73 in *Advanced Measurements Tutorial*.

Tektronix – CSS500										
File Edit View Measure Configure Execute Help										
Open	Save	Global	Results	Status	Meas Sel	Meas Seg	Test ID	Setups	Limits	Print
Worksheet: <untitled>		Site: Tektronix-Beaverton		View Sequence Filter is On						
Chan Table: std.cht		Test ID: test 43:16:35								
	Visual Carrier Lev (dBmV)	Visual Carrier Freq (MHz)	Aural Carrier Lev (dBc)	Aural Frequency Offset (MHz)	FCC Baseband	Multiburst				
2 55.25	21.8	55.49232 **	-27.7 **	4.495524 *	ALARM **	ALARM **				
4 67.25	-1.2	67.494462 **	-31.9 **	4.500718	ALARM **	ALARM **				
6 83.25	44.1	83.304962 **	-32.1 **	4.507761 **	ALARM **	ALARM **				

Figure 2-30: Measurement sequence results with view sequence filter on

- Choose Measurement Sequence Results, from the View menu, to turn the Measurement Sequence View Filter off and return to a normal display.

## Measurement Sequences Using Auto Selection

You may have noticed a group in the Measurement Sequence dialog box labeled Auto Selection. These four buttons allow you to quickly set up a Measurement Sequence that might be run on a regular basis. The four push buttons are: FCC Pre-Converter, FCC Post-Converter, FCC Headend Msmts, and 24 Hour Test. You can add other measurements to the sequence, before or after choosing an Auto Selection command button.

---

**NOTE.** *Non-US countries have only the 24 Hour Test button available, because the rest of the Auto Selection buttons are for making FCC (a US regulatory agency) required measurements.*

---

Table 2–1 lists the measurements available under the Auto Selection command buttons. They all have Carrier Levels and Frequencies for all channels. Other measurements are for user-selected channels only.

**Table 2–1: Measurements executed by Auto Selection buttons**

Channels that are Measured	Auto Selection Button			
	FCC Pre-Converter	FCC Post-Converter	FCC Headend	24 Hour Test <sup>1</sup>
All Channels	Carrier Levels and Frequencies	Carrier Levels and Frequencies	Carrier Levels and Frequencies	Carrier Levels and Frequencies
Selected Channels	ICR	Carrier to Noise Ratio	FCC Baseband	
Selected Channels		CSO		
Selected Channels		CTB		
Selected Channels		Cross Modulation		
Selected Channels		Hum		

<sup>1</sup> The 24 Hour Test is automatically set to run 4 times at 6 hour intervals.

### Set Up an Auto Selection Measurement Sequence

1. From the Configure menu, choose Measurement Sequence. The Measurement Sequence dialog box appears.
2. Choose the Clear Sequence command button to erase any old Measurement Sequence information.

Mouse	Keyboard
Click on the Clear Sequence command button with the left mouse button.	Press ALT+c.

- Choose the FCC Pre-Converter command button from the Auto Selection group. The FCC Pre-Converter Measurements dialog box appears as shown in Figure 2-31.

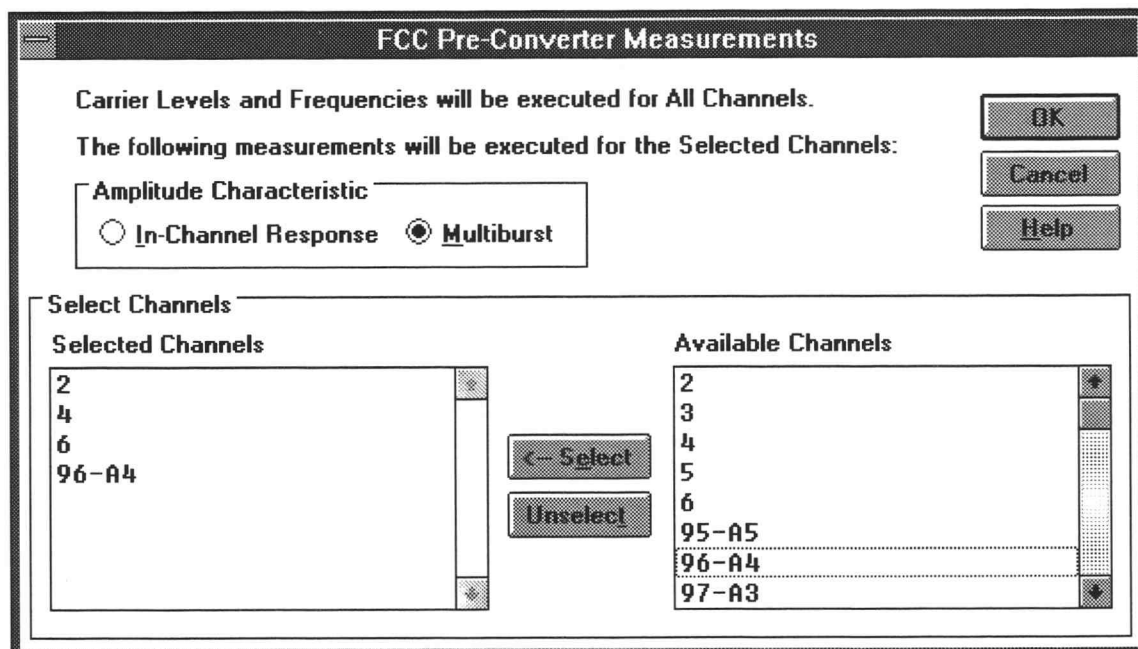

Figure 2-31: The FCC Pre-Converter Measurements dialog box

- Select the Multiburst option button for the Amplitude Characteristic group.

Mouse	Keyboard
Click on the Multiburst option button with the left mouse button.	Press ALT+m.

- Select several channels from the Available Channels list box and place them in the Selected Channels list box.

Mouse	Keyboard
Double-click the left mouse button on the channel name for single channels. For several channels, click on the first channel with the left mouse button, then hold down SHIFT and click on the last channel in the list with the left mouse button. Then choose the <-Select command button.	Press TAB until the cursor is in the Available Channels list box. Use the arrow keys to select a channel or, to select several channels at a time, hold down SHIFT while moving through the list with the arrow keys. Add the selected channel(s) to the Selected Channels list box by pressing ALT+e.

6. Choose the OK command button to return to the Measurement Sequence dialog box.
7. Add a Carrier to Noise measurement to the channels that also have a Multiburst measurement.

Mouse	Keyboard
Double-click those cells with the left mouse button.	Press TAB until the cursor is in the spreadsheet. Use the arrow keys to move to the cell, then select the cell by pressing the spacebar.

The Measurement Sequence dialog box should look similar to Figure 2–32.

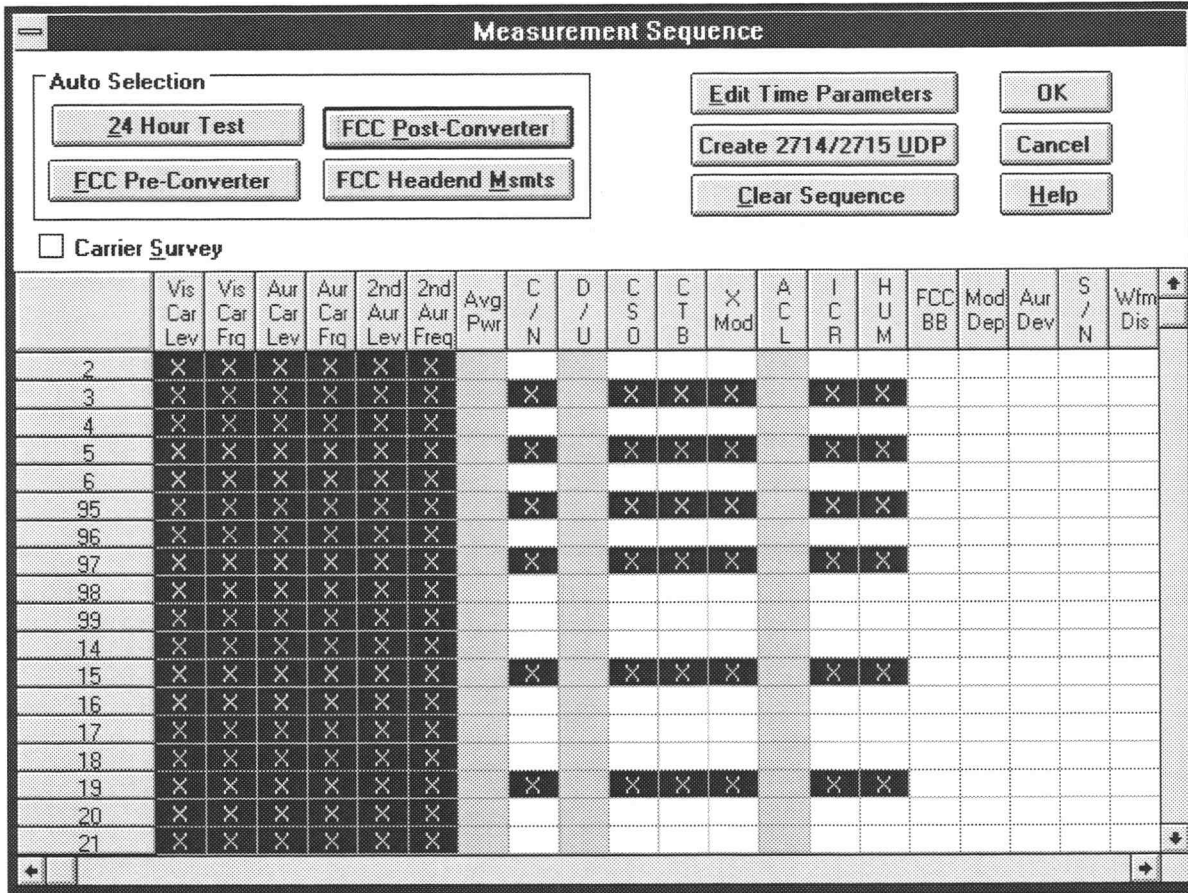

Figure 2–32: Measurement Sequence dialog box after using an Auto Selection command button and adding additional measurements

8. Choose the OK command button to return to the spreadsheet.

**Run an Auto Selection Measurement Sequence.** You run the Auto Selection Measurement Sequence in the same way that you run any other Measurement Sequence.

**Carrier Survey.** The Carrier Survey check box in the Measurement Sequence dialog box allows you to quickly select all of the Carrier Level and Frequency measurements. See page 3–58 for more details on the Carrier Survey check box.

## Display the Picture (Optional)

There will be times that you want to be able to see what the broadcast signal looks like while you are making measurements on it. For example, your first channel just miserably failed its last FCC Measurements check and you would like to see the amount of picture distortion. CSS500 has the ability to show you the picture directly on the computer screen if you have the appropriate hardware installed.

The Picture command displays a video picture of what is presently on a given channel (shows a complete active picture). The channel is whatever the demodulator happens to be tuned to at the time, or you can use the Tune to Channel command to select a channel. To use the Picture command, you must have a video board and software driver installed in your PC. (The CSS500 package does not include the video board and driver). The video board and driver must be active when the Picture command is called. The default driver is the Video Blaster. Refer to page 3–40 for information on using other drivers.

Use the following procedure to display your first channel:

1. From the control menu box, use Switch To to go to the Windows Program Manager.
2. Start your video driver.
3. Return to the CSS500 application.
4. Configure your equipment to provide the desired video signal to the video card in the PC.
5. From the View menu, choose Picture.

The picture is displayed on the computer screen.

6. To leave the Picture display from the control menu box in the picture window, choose Close. Or you can hide the picture by clicking anywhere in the CSS500 application window.

## Print (Optional)

Now that you have some data to look at, it is time to print out some worksheets and reports.

1. Check your printer setups. From the File menu, choose Print Setup. The Print Setup dialog box appears, as shown in Figure 2–33.

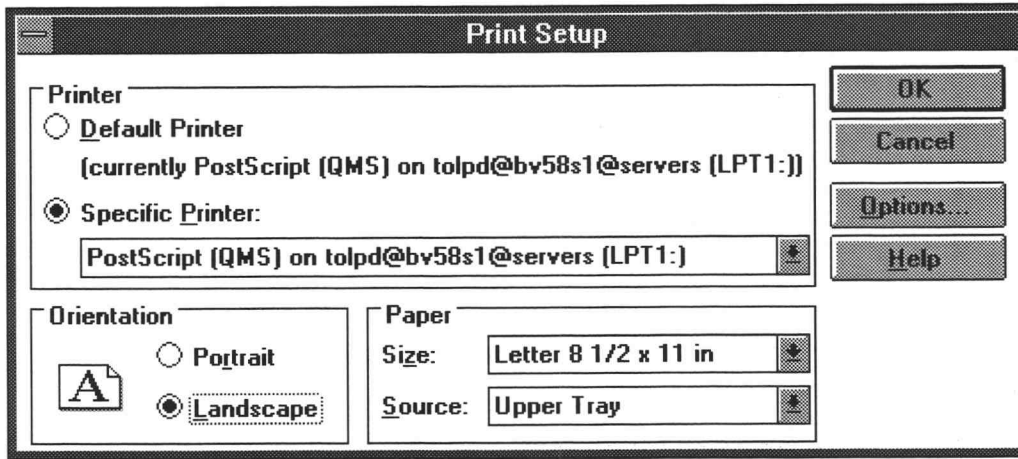

Figure 2-33: The Print Setup dialog box

This dialog box is identical to the standard Windows Print Setup dialog box. (Use the *Windows 3.1 User's Guide* and on-line help for any problems.) When the printer is set correctly, choose the OK command button. The printer is now ready to use.

---

**NOTE.** As a general rule, use landscape orientation for easier-to-read reports.

---

- From the File menu, choose Print. The dialog box shown in Figure 2-34 appears.

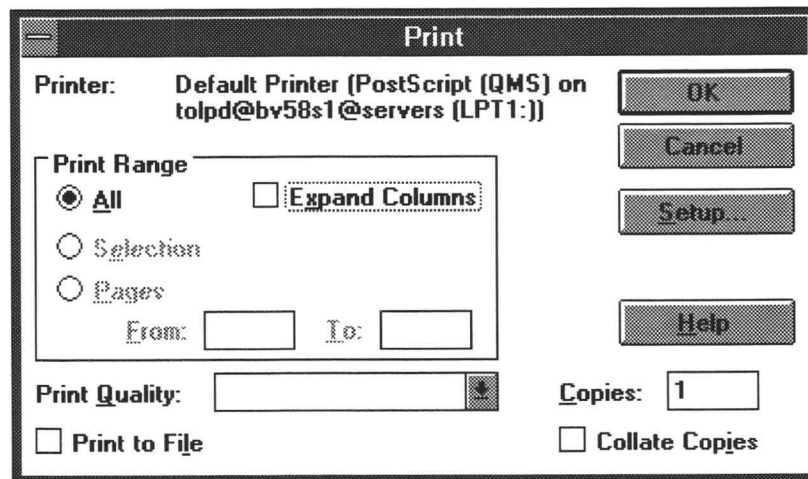

Figure 2-34: The Print dialog box



3. Select the appropriate options and then choose OK to print.

---

**NOTE.** Before printing out a worksheet, select the View Used option from Measurements and Channels in the View menu. This will automatically limit the display to measurements and channels that have results.

---

### Print Out the Worksheet

Choose the Print command button on the Button Bar. The entire worksheet prints.

---

**NOTE.** The Print dialog box has a special check box, Expand Columns. This option allows all of the measurements that would normally only show Pass, Caution, or Alarm to expand, giving all of the numerical results. For example, Audio expands to 20 columns to display all of the measurements. The columns that expand are: CSO, CTB, Hum/LFD, FCC Baseband, Signal to Noise, Waveform Distortion, Multiburst, and Audio.

---

### Print Out the Results Detail Display

1. Display the Results Detail for the first channel of the FCC Baseband measurement. (Select the cell, then click on the Results button on the Button Bar, or click on the cell with the right mouse button.)
2. Choose the Print command button in the Results Detail Display.
3. Leave the Results Detail Display by choosing the Close command button.

## End of the Tutorial

You have just completed the tutorial for CSS500. At this point, you should be able to do the following:

- Select cells. (See page 2–10.)
- Enter worksheet header information. (See page 2–13.)
- Make simple measurements. (See page 2–17.)
- Enter the Results Detail display. (See page 2–22.)
- Enter the Global View. (See page 2–23.)
- Define a Measurement Sequence. (See page 2–25.)
- Execute a Measurement Sequence. (See page 2–29.)

- Define a Measurement Sequence using the Auto Selection buttons. (See page 2–31.)
- View what is being broadcast on the computer monitor. (See page 2–35.)
- Set up your printer. (See page 2–35.)
- Print out assorted reports. (See page 2–37.)

If you don't feel comfortable with any of the above topics, please go back and review them before continuing.

# Advanced Setups Tutorial

This chapter explains how to set up your system to give you only the information that you want and to make the most accurate measurements. The following topics are covered:

- Selecting and configuring the demodulator
- Reviewing the RS-232 and GPIB connections
- Setting the 271X controls
- Setting the TDC-10 controls
- Specifying how the measurements are made
- Setting the correct VITS locations
- Attaching a different Channel Table
- Selecting whether or not to collect history
- Selecting the Power Level Units
- Turning the user prompts and alarm messages on or off

## Select and Configure the Demodulator

From the Configure menu, choose Demodulator (see Figure 2–35). Next, choose either TDC-10 / 1450A, TV1350, Rohde & Schwarz EMFP, or None depending on which demodulator is in your system. A check mark indicates the selected demodulator.

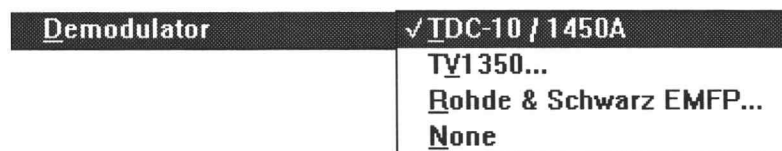

Figure 2–35: Selecting Demodulator from the Configure menu

If the TV1350 or EMFP is the selected demodulator, then additional configuration steps might be required. A dialog box appears as soon as either of these demodulators is chosen (see Figure 2–36). Edit these parameters as required (if the TV1350 is being used in a non-system M setup, you must use SAW). The CSS500.INI file stores these values. (See Appendix E for more information on the CSS500.INI file.)

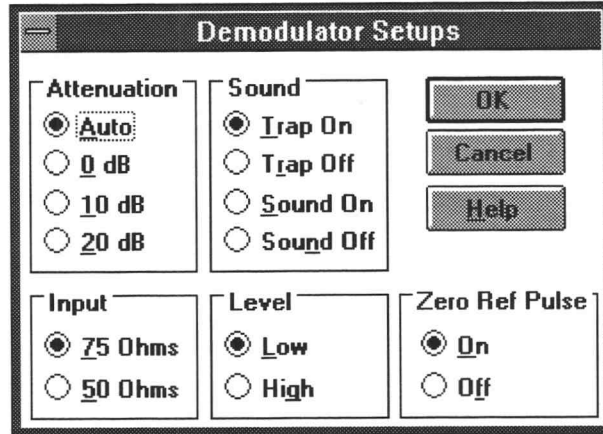

Figure 2–36: The Demodulator Setups dialog box

**NOTE.** The CSS500.INI file controls the front panel settings. Therefore, no matter what the front panel on the Rohde & Schwarz demodulator or TV1350 indicates, the actual control parameters are in the CSS500.INI file and are set in the Demodulator Setup dialog box.

## Configure Connections

The first time you run the CSS500 application or any time that the test equipment connections change, choose Connections from the Configure menu. The dialog box looks like the one shown in Figure 2–37 (if the TDC-10/1450A combination is the selected demodulator). Verify that CSS500 shows the correct addresses of the test equipment.



**CAUTION.** To ensure proper operation and prevent software conflicts, verify that no two instruments are assigned to the same port or GPIB address. This applies even if an instrument is not connected or used.

**Connections**

2714/2715 Spectrum Analyzer

GPIB    GPIB Address: 0

RS-232    COM Port: 1    Baud Rate: 4800

VM700A    GPIB Address: 1

Demodulator    IDC-10 GPIB Address: 2

Switcher Control Port

COM Port: 3    Baud Rate: 9600

Flow Control: NONE    Parity: None

Stop Bits: 1    Data Bits: 8    Delay: 1

RS-232 Violations Reporting

COM Port: 3    Baud Rate: 9600

OK  
Cancel  
Help

Figure 2-37: The Connections dialog box

## Configure Measurement Setups

There are many different ways that your system can execute measurements. The Measurement Setups dialog box tells CSS500 how your system needs to be set up to make measurements and get the best results. There are setup parameters that affect all channels and some that are channel specific.

From the Configure menu, choose Measurement Setups, or choose the Setups command button from the Button Bar. The Measurement Setups dialog box looks similar to Figure 2-38:

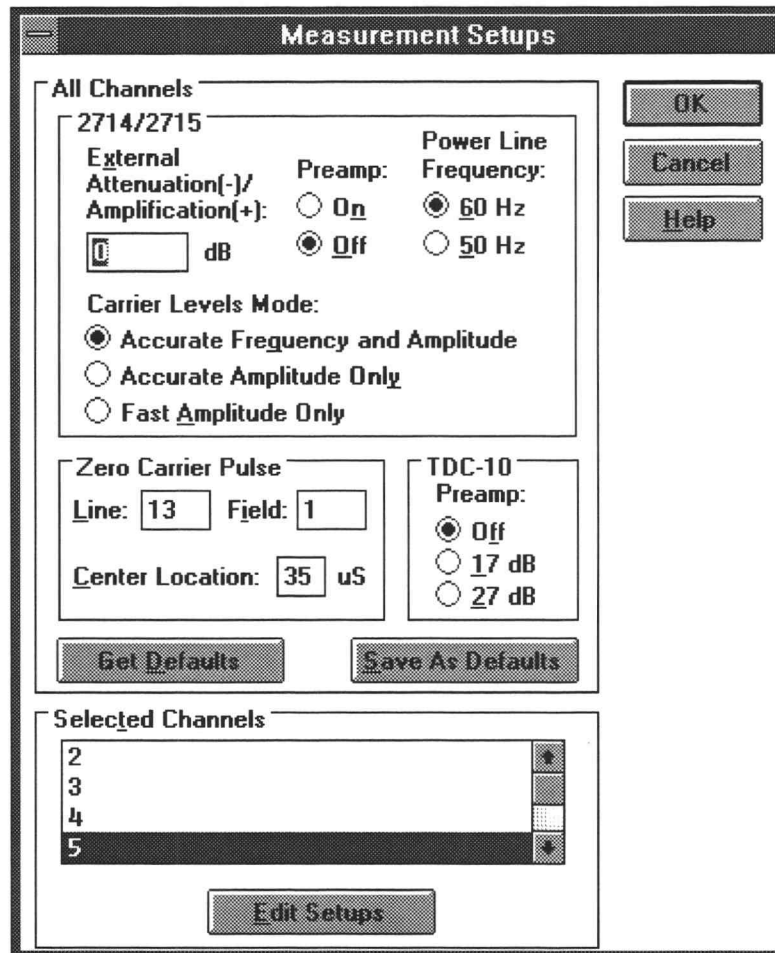

Figure 2–38: The Measurement Setups dialog box

### The All Channels Group

The All Channels group contains settings that specify how measurements are made on all channels.

#### 2714/2715 Subgroup

- External Attenuation/Amplification. Enter the attenuation or amplification (in dB) of the test point in this text box. For example: if the measurements are being made at a 10 dB down test point, enter –10 dB.

- Preamp. The Preamp allows increased sensitivity when measuring low level signals. Select the On or Off option button to match your measurement needs. See the 2714 manual for more information on the correct settings.

---

**NOTE.** *The 2715 automatically sets the preamp as required for each measurement.*

---

- Power Line Frequency. This is the power line frequency of your system.
- Carrier Levels Mode. These option buttons select how the Carrier Level measurements are made. This includes both regular measurements and Carrier Surveys. The options are given below:

Accurate Frequency and Amplitude (recommended)  
Accurate Amplitude Only  
Fast Amplitude Only

#### Zero Carrier Pulse Sub-Group

---

**NOTE.** *This sub-group does not set the Zero Carrier Pulse for the demodulator. It only indicates the location for the VM700A.*

---

The Zero Carrier Pulse is available from the demodulator. The VM700A uses the Zero Carrier Pulse as a timing reference. Make sure that the reference set here is the same as the reference set with internal jumpers in the demodulator. For more information, please see the demodulator manual.

Enter the Line Number, Field, and Center Location in the text boxes.

#### TDC-10 Sub-Group

---

**NOTE.** *The TDC-10 sub-group is only available if the TDC-10 is the selected demodulator.*

---

- Preamp. The Preamp allows improved sensitivity when measuring low level signals. Select the RF preamplification according to the instructions found in the TDC-10 manual. Select the Off, 17 dB, or 27 dB option button.

### **Selected Channels Group**

The Selected Channels group allows you to continue customizing the measurements down to the individual channel. Some of the reasons why you might want to have different setups for different channels include: different locations of the VITS lines, lack of VITS signals on some channels (measurements must be made using RF methods), or inability to turn the carrier off on some channels (need to use alternative methods to make some measurements). The sub-groups found under Selected Channels are: Carrier to Noise, VM700A VITS, ACL, Mod. Depth, VM700A Msmts, CSO, CTB, and In Channel Response.

Measurements are faster and record keeping is easier if the VITS signals are correct. In both NTSC and PAL, if the locations are not correct, the VM700A will automatically search for them at measurement time. The VM700A puts the location of the VITS that it finds in the text boxes for future reference.

To enter the Edit Setups dialog box for channel 2: double-click on channel 2 in the Selected Channels list box or press TAB until the cursor is in the Selected Channels list box, then use the arrow keys to highlight the desired channel (2). Press ALT+e to enter the Edit Setups for Channel 2 dialog box shown in Figure 2-39. (Figure 2-40 shows a PAL version of the dialog box.)



**Edit Setups for Channel 2 55.25 MHz**

<p><b>Carrier to Noise</b></p> <p><input checked="" type="radio"/> <b>Auto</b></p> <p><input type="radio"/> Auto with Pause</p> <p><input type="radio"/> Gated</p> <p>Noise Bandwidth: <input type="text" value="4"/> MHz</p>	<p><b>VM700A VITS</b></p> <table style="width: 100%; border-collapse: collapse;"> <thead> <tr> <th></th> <th style="text-align: center;">Line</th> <th style="text-align: center;">Field</th> </tr> </thead> <tbody> <tr> <td><b>Multiburst:</b></td> <td style="text-align: center;"><input type="text" value="17"/></td> <td style="text-align: center;"><input type="text" value="1"/></td> </tr> <tr> <td><b>Composite:</b></td> <td style="text-align: center;"><input type="text" value="18"/></td> <td style="text-align: center;"><input type="text" value="1"/></td> </tr> <tr> <td><b>Combination:</b></td> <td style="text-align: center;"><input type="text" value="17"/></td> <td style="text-align: center;"><input type="text" value="2"/></td> </tr> <tr> <td><b>Noise (Quiet):</b></td> <td style="text-align: center;"><input type="text" value="12"/></td> <td style="text-align: center;"><input type="text" value="1"/></td> </tr> <tr> <td><b>Sin(x)/x:</b></td> <td style="text-align: center;"><input type="text" value="17"/></td> <td style="text-align: center;"><input type="text" value="2"/></td> </tr> </tbody> </table>		Line	Field	<b>Multiburst:</b>	<input type="text" value="17"/>	<input type="text" value="1"/>	<b>Composite:</b>	<input type="text" value="18"/>	<input type="text" value="1"/>	<b>Combination:</b>	<input type="text" value="17"/>	<input type="text" value="2"/>	<b>Noise (Quiet):</b>	<input type="text" value="12"/>	<input type="text" value="1"/>	<b>Sin(x)/x:</b>	<input type="text" value="17"/>	<input type="text" value="2"/>	<p><b>ACL</b></p> <p><input type="radio"/> Upper</p> <p><input type="radio"/> Lower</p> <p><input checked="" type="radio"/> Both</p> <p style="text-align: right;"> <input type="button" value="OK"/>  <input type="button" value="Cancel"/>  <input type="button" value="Help"/> </p> <p style="text-align: center;"> <input type="button" value="Get Defaults"/>  <input type="button" value="Save As Defaults"/>  <input type="button" value="Copy to All Channels"/> </p>
	Line	Field																		
<b>Multiburst:</b>	<input type="text" value="17"/>	<input type="text" value="1"/>																		
<b>Composite:</b>	<input type="text" value="18"/>	<input type="text" value="1"/>																		
<b>Combination:</b>	<input type="text" value="17"/>	<input type="text" value="2"/>																		
<b>Noise (Quiet):</b>	<input type="text" value="12"/>	<input type="text" value="1"/>																		
<b>Sin(x)/x:</b>	<input type="text" value="17"/>	<input type="text" value="2"/>																		
<p><b>Mod. Depth</b></p> <p><input type="radio"/> Baseband</p> <p><input checked="" type="radio"/> RF</p>	<p><b>VM700A Msmts.</b></p> <p><input checked="" type="radio"/> Source A,C</p> <p><input type="radio"/> Source B</p>																			
<p><b>CSO</b></p> <p><input checked="" type="radio"/> Auto</p> <p><input type="radio"/> Auto with Pause</p> <p><input type="radio"/> Single Sweep</p> <p><input type="radio"/> Gated</p> <p><b>Test Locations (MHz):</b></p> <p><input type="text" value="-1.25"/> (Rel)</p> <p><input type="text" value="-.75"/> (Rel)</p> <p><input type="text" value=".75"/> (Rel)</p> <p><input type="text" value="1.25"/> (Rel)</p> <p><input type="text"/> (Rel)</p>	<p><b>CTB</b></p> <p><input checked="" type="radio"/> Auto</p> <p><input type="radio"/> Auto with Pause</p> <p><input type="radio"/> Single Sweep</p> <p><b>Test Locations (MHz):</b></p> <p><input type="text" value="0"/> <input checked="" type="radio"/> Rel <input type="radio"/> Abs</p> <p><input type="text"/> <input checked="" type="radio"/> Rel <input type="radio"/> Abs</p> <p><input type="text"/> <input checked="" type="radio"/> Rel <input type="radio"/> Abs</p> <p><input type="text"/> <input checked="" type="radio"/> Rel <input type="radio"/> Abs</p> <p><input type="text"/> <input checked="" type="radio"/> Rel <input type="radio"/> Abs</p> <p><input type="text"/> <input checked="" type="radio"/> Rel <input type="radio"/> Abs</p>	<p><b>In-Channel Response</b></p> <p><input type="radio"/> Baseband (Sin(x)/x)</p> <p><input checked="" type="radio"/> RF <input type="checkbox"/> Gated</p> <p><b>Test Locations (MHz):</b></p> <p><input type="text" value="-.5"/> (Rel)</p> <p><input type="text" value=".5"/> (Rel)</p> <p><input type="text" value="1.25"/> (Rel)</p> <p><input type="text" value="2"/> (Rel)</p> <p><input type="text" value="3"/> (Rel)</p> <p><input type="text" value="3.75"/> (Rel)</p>																		

Figure 2-39: The Edit Setups dialog box for channel 2 (NTSC)

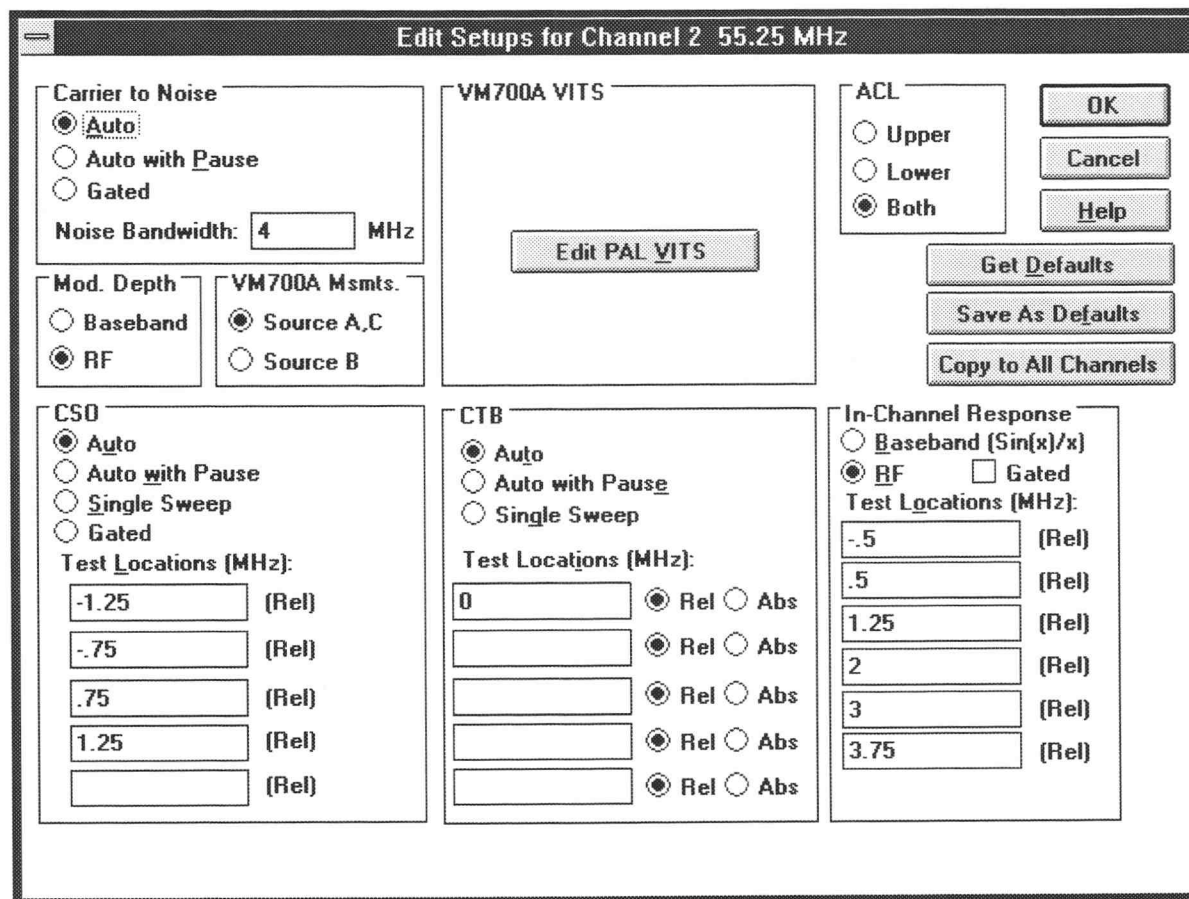

Figure 2-40: The Edit Setups dialog box for channel 2 (PAL)

**Carrier To Noise Group.** Select the Auto, Auto with Pause, or Gated (the 2715 calls this “in service” measurements) option button. Auto with Pause expects the carrier to be turned off and will prompt the operator to do so. Gated (Gated measurements are only available for the 2715) allows you to make the measurements on a “quiet” or unmodulated line (the quiet line is found in the Channel Table. See Appendix C, page C-30, for more information.). This allows you to make the measurements without taking the system out of service.) Enter the bandwidth for the noise calculation in the Noise Bandwidth text box.

**Modulation Depth Group.** Select how to make the Modulation Depth measurement. The options are to use RF (the 2714/2715) or baseband (VM700A).

**VM700A Measurements Group.** Select the input for the VM700A. It can use either Source A, C or Source B.

---

**NOTE.** *The ICPM measurement cannot be made if Source B is selected.*

---

**VM700A VITS Group.** Enter the locations of the various VITS lines in the Line and Field text boxes. The VITS signals needed to make the measurements in the NTSC measurement list are: Multiburst, Composite, Combination, Quiet Line, and Sin(x)/x. You don't have to enter the VITS locations; the VM700A will search for them whenever they are required to make a measurement.

If the Channel Table for the current worksheet uses PAL as the video standard, then there is a command button in this group. The command button allows you to go to the PAL VITS dialog box. (There are more VITS signals in PAL and they will not all fit in the available space.)

**CSO Group.** The measurement options are: Auto, Auto with Pause, Single Sweep, or Gated. Auto performs this measurement without turning the carrier off. Auto with Pause expects the carrier to be turned off and will prompt the operator to do so. Single Sweep also expects the carrier to be turned off and will prompt the user to turn it off. It also performs all of the measurements in one sweep, instead of one sweep for each test location. Gated means that the measurement is made on a "quiet" (unmodulated) line. This is only available for the 2715.

Enter the frequency locations (relative to the visual carrier) where this measurement should be made.

See *Distinguishing 2714 CTB and CSO Measurements* on page 3–75 for a discussion of how the CSO and CTB measurements are calculated.

**ACL Group.** Measures the power in the channels adjacent to the channel under test. This is a headend test with the 2715 connected to the test port of the modulator. Select Upper to measure the power in the upper adjacent channel only, Lower to measure the lower adjacent channel only, or Both to measure both the upper and lower channels.

**CTB Group.** The measurement options are: Auto, Auto with Pause, or Single Sweep. Auto performs this measurement without turning the carrier off. Auto with Pause expects the carrier to be turned off and will prompt the operator to do so. Single Sweep also expects the carrier to be turned off and will prompt the user to turn it off. It also performs all of the measurements in one sweep, instead of one sweep for each test location.

Enter either the absolute or relative frequency locations (relative to the visual carrier) where you want this measurement made.

See *Distinguishing 2714 CTB and CSO Measurements* on page 3–75 for a discussion of how the CSO and CTB measurements are calculated.

**In-Channel Response Group.** Make the In-Channel Response measurement using either baseband or RF methods. Therefore, if the VM700A or the Sin(x)/x signal is not available, make this measurement using the 271X.

Enter the frequencies (relative to the visual carrier) where you want the measurement calculated (up to 6 locations for RF and 7 locations for baseband) in the Test Locations text boxes.

If it is using the RF method the signal could also be gated. (Gated means that the measurement is made on a test line and the carrier does not need to be turned off.) The 2715 is the only instrument that can perform gated measurements.

**Command Buttons for the Edit Setups for Channel XX Dialog Box.** There are three special command buttons located in the Edit Setups for Channel XX dialog box. They are Get Defaults, Save as Defaults, and Copy to All Channels.

- **Get Defaults.** The Get Defaults command button takes the default Measurement Setup values from the CSS500 initialization file and places them in the text boxes. It also sets the option buttons to the default values. You select which groups of default values you want loaded using the check boxes as shown in Figure 2–41.

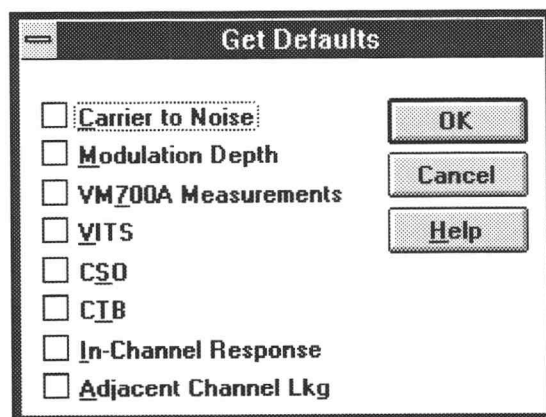

Figure 2–41: The Get Defaults dialog box

- **Save as Defaults.** This command button takes the current entries in the text boxes and selections of the option buttons and stores them as the default Measurement Setup values in the CSS500 initialization file. It only saves as defaults, the groups selected in the check. The rest keep the current defaults. When a new worksheet starts, these defaults load automatically. You can also load these defaults into selected channels using the Get Defaults command button when editing the setups for those channels.
- **Copy to All Channels.** The Copy to All Channels command button takes the settings on the current Edit Setups for Channel dialog box for the selected groups and copies them to all of the channels. However, if the current channel is digital, CTB and CSO setups are copied only to digital channels. Similarly, if the current channel is analog, CTB and CSO setups are copied only to analog channels.

---

**NOTE.** For both *Save As Defaults* and *Copy to All Channels*, the changes that they make take place immediately. You don't need to wait until you exit the dialog box.

---

**Leave the Edit Setups for Channel XX Dialog Box.** Save all of the changes and leave the Edit Setups for Channel XX dialog box and return to the Measurements Setup dialog box by choosing OK.

#### Leave the Measurement Setups Dialog Box

Save all of the changes, leave the Measurement Setups dialog box and return to the spreadsheet by choosing the OK command button.

## Attach a Different Channel Table

---

**NOTE.** The CSS500 only recognizes a Channel Table by its name, not its contents. It will not load a changed Channel Table into an instrument if it already has a Channel Table by that name.

---

There will always be a Channel Table associated with a worksheet (the default), so you can make measurements without changing the Channel Table. (If the default Channel Table is corrupt or not available, the system will always try to load the std.cht Channel Table.) Please see Appendix C or the on-line help for more information about the Channel Table Editor (CTLOADE.EXE). This section only deals with changing from one Channel Table to another.

1. Choose Worksheet Info from the Configure menu. The Worksheet Info dialog box appears (see Figure 2-42).

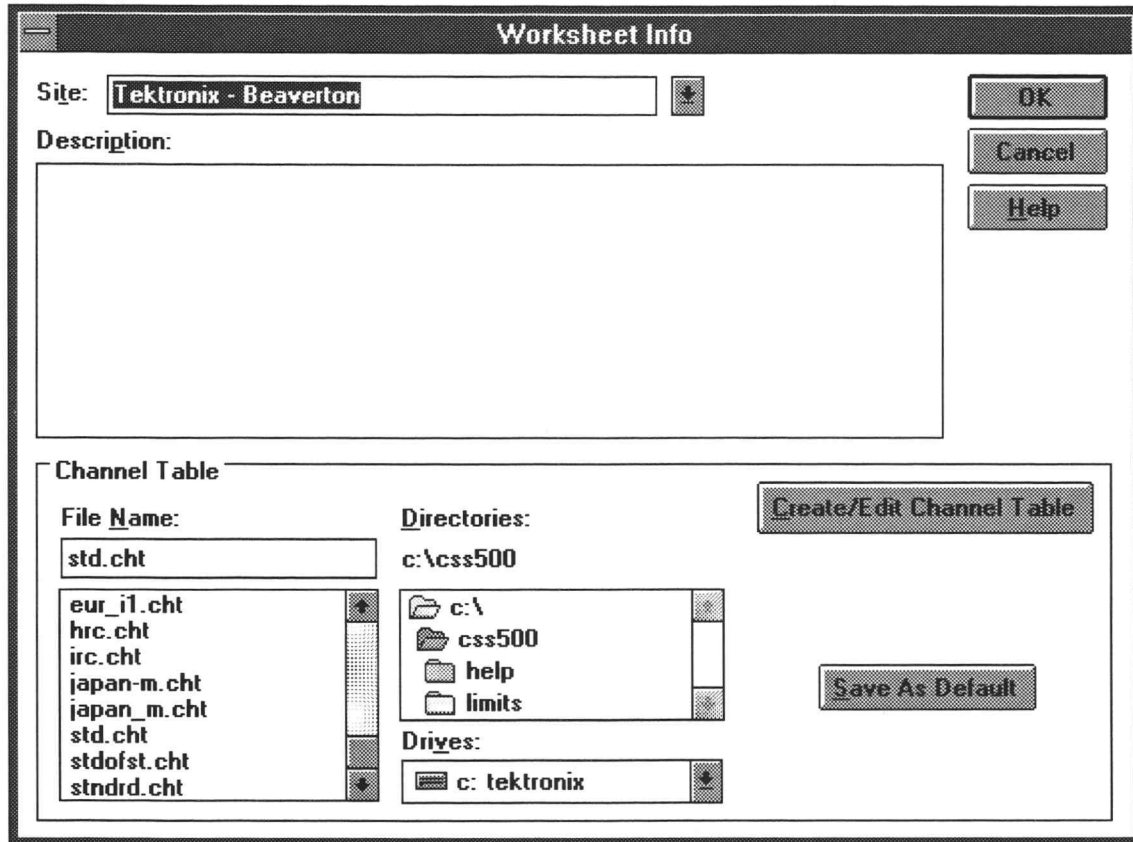
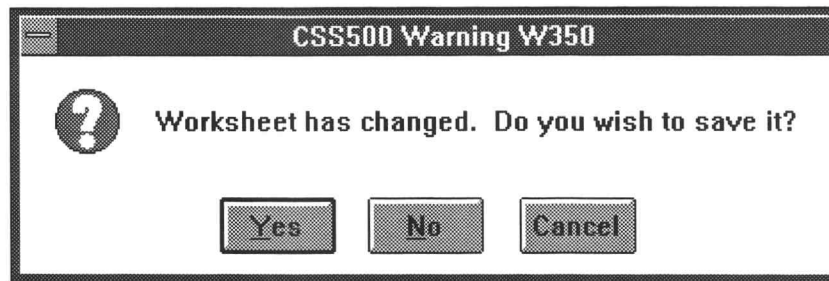

Figure 2-42: The Worksheet Info dialog box used to change the Channel Table

2. Select a Channel Table file from the list.
3. Choose OK to save the changes and exit the dialog box. The Warning in Figure 2-43 may appear if there are measurements in the current worksheet. This is to remind you that you are creating a new worksheet whenever you change the Channel Table. (Only one Channel Table is allowed in each worksheet.)



**Figure 2-43: Warning message that the worksheet has changed**

4. Choose the Yes command button to save the old worksheet. The new worksheet, with the new Channel Table, is <untitled>.

You are now ready to make measurements using the new Channel Table and worksheet. If this Channel Table does not exist in the instruments (by name), CSS500 will automatically load it as soon as it is needed.

The exception is the TV1350 and EMFP Demodulators. They load the frequencies from the channel table only as needed. They do not load the Channel Table into their own memories.

## Configuration Preferences

There are several ways to configure the CSS500 application that are not directly related to making measurements. These options are located in the Configure menu under Preferences.

From the Configure menu, choose Preferences. The Preference dialog box looks like Figure 2-44.

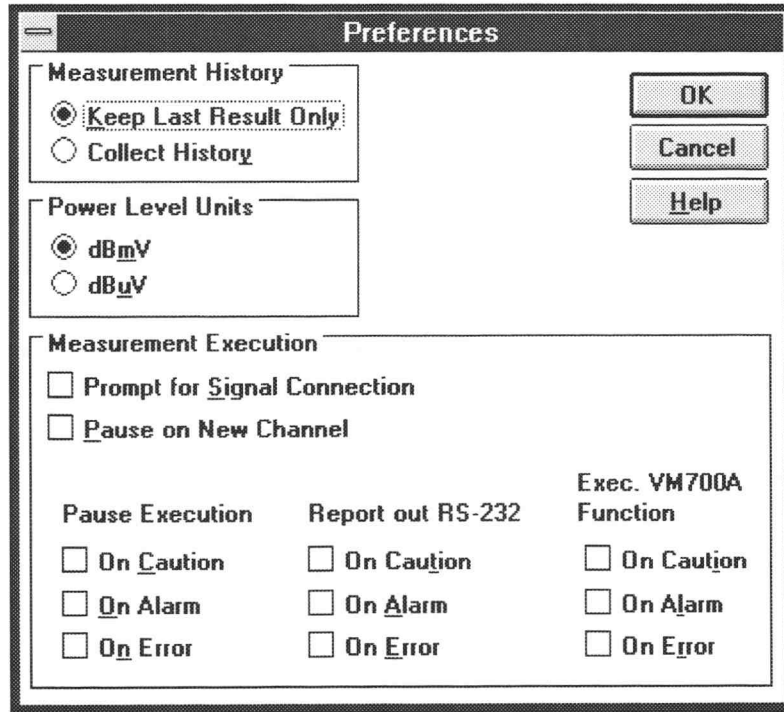

Figure 2-44: The Preferences dialog box

There are three Preferences groups. They are: Measurement History, Power Level Units, and Measurement Execution.

**Measurement History Group**

This group allows you to collect history or keep only the results of the last measurement. If you choose to collect history, the previous results are saved but not visible on the spreadsheet. The spreadsheet is actually three dimensional (the three dimensions are Channel, Measurement, and Time) but only two dimensions are visible (Channel and Measurement). Only the top (most recent) measurement of the time stack is visible on the spreadsheet. The three-dimensional spreadsheet structure is illustrated by Figure 2-45.



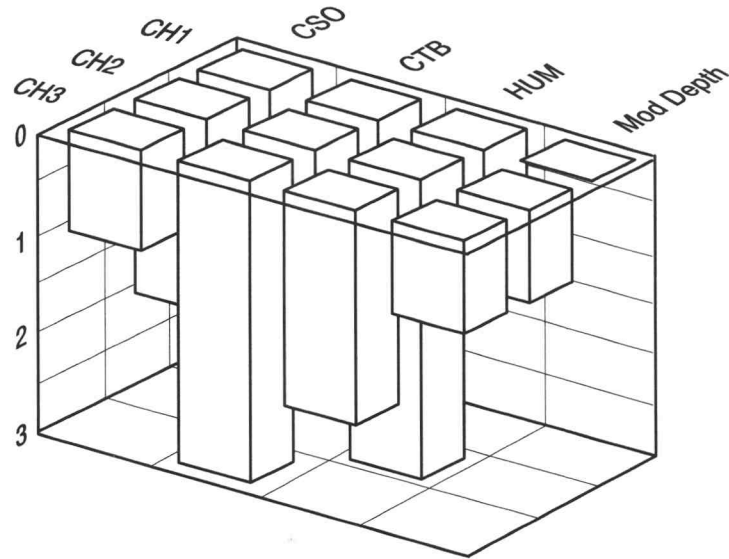
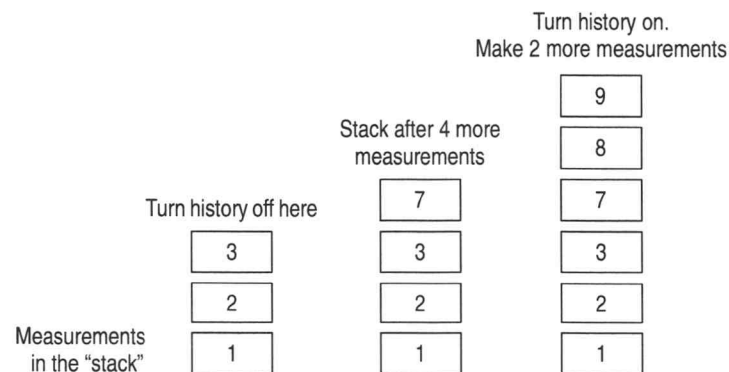

**Figure 2-45: A three-dimensional view of a spreadsheet.**

When Collect History is selected, measurement results are saved beginning with the current measurement (what is currently in the spreadsheet).

An example of why you would want history collected on a measurement is the 24 Hour variation test. This measurement is performed by running the Carrier Levels and Frequencies four times in a 24 hour period and comparing the collected results. Another example is a measurement that is failing sporadically. By taking the measurement over a period of time and collecting the history, a trend might become evident.

The way that the history is saved is best illustrated by an example of the life of a cell, as shown in Figure 2-46.



**Figure 2-46: The effect of turning Collect History off and then on**

The first column in Figure 2–46 shows three measurements made with Collect History turned on. After the third measurement, the history is turned off and four more measurements are made (for a total of seven). The results are shown in the second column. You still have the first three measurements stored in history, measurements four through six have been written over, and measurement seven is presently displayed in the cell. After the seventh measurement, Collect History is turned back on and two more measurements are made (for a total of nine). The results are shown in the third column. The first three measurements are still there and seven through nine are added to the history stack.

If you want to view the history of a measurement, one way is to look at the Results Detail display. In this display, you can flip through the results to see what the measurement results were in the past (a lot like flipping through sheets in a log book).

### Power Level Units Group

The option buttons select between Visual Carrier Level and Average Power Level units in dBmV (referenced to 1 mV) or dBuV (referenced to 1  $\mu$ V).

### Measurement Execution Group

These check boxes select:

- whether or not to prompt the operator to make the required equipment connections before a requested measurement is executed
- whether or not to pause on a new channel
- the type of action to take (if any) if a measurement falls into an alarm or caution range or has some type of error

**Prompt for Signal Connection.** An example of this type of prompt is a dialog box requesting the operator to properly connect the signal under test to the test equipment. You must choose the OK button before the measurement will continue. This allows the operator to manually switch the RF signal between the 271X and demodulating equipment using one RF signal tap rather than requiring a splitter.

If this option is checked and a measurement is executed that requires both RF and baseband testing, all of the RF measurements are done first. Then all of the baseband measurements, so the connection only needs to be changed once.

**Pause on New Channel.** If you want to be informed that measurements are ready to begin on a new channel, select this check box. If it is turned on, the measurements stop whenever a new channel is encountered until you choose the OK button. One of the things this allows you to do is tune an external preselector to a new channel.

**Alarm, Caution, or Error Conditions.** These check boxes allow you to be notified in several ways if an error, alarm, or caution flag occurs during a measurement. Three different actions can occur: a report can go out the RS-232 port, the VM700A alarm function can operate, or the CSS500 can stop making measurements and post an alarm message. You can use any combination of these options.

The Pause Execution check boxes stop the measurements if a measurement is encountered that is in Alarm (cell is red), Caution (cell is yellow), or Error (cell is blue) until the user chooses the OK command button. It is useful for system monitoring because it forces you to become aware of bad or non-standard conditions. It also sends a CSS500~ALARM\_OFF function to the VM700A.

Report out RS-232 sends a Violations Report out a Com Port (set with the Connections dialog box). Based on the selections, the following information is sent: Site Name, Measurement Column Heading, Channel Number, Program, Condition Type (alarm, caution, or error), and Date/Time. This information is tab-delimited and packetized. (For more information on intercepting an alarm, see *Measurement Execution* on page 3-54.)

Execute VM700A Function calls a VM700A function when the selected conditions occur. When this is enabled and a condition occurs, a specific internal VM700A function is executed. It is CSS500~ALARM\_ON. This activates the alarm. This default function is loaded in the VM700A as required. First CSS500 attempts to play back the appropriate function. If there is no function by that name, then the default function loads into the VM700A. This function controls the relay switch located on the back of the VM700A between the two RS-232 ports. CSS500~ALARM\_ON closes the relay. (CSS500~ALARM\_OFF opens it.) You can create your own function by the same name. CSS500 will not overwrite the function if it already exists in the VM700A. The functions created by the user can perform any type of action. This can be printing messages on the printer or even dialing a personal pager by way of a modem attached to one of the VM700A Serial Ports. See the VM700A manuals for more information on how to write your own functions.

---

**NOTE.** *Pause Execution sends the CSS500~ALARM\_OFF VM700A function. The default CSS500~ALARM\_OFF function opens the relay on the rear of the VM700A. (This is the same relay that the CSS500~ALARM\_ON function closes.)*

---

**Set the Preferences**

Set the Preferences to:

- Collect History
- dBmV Power Level Units
- Prompt for Signal Connection
- Pause on New Channel
- Pause Execution — On Alarm

**Make Measurements  
Using the Defined  
Preferences**

1. Select the first two channels' Carrier Levels and Frequencies.
2. From the Measure menu, choose Current Selection. First, you are prompted to connect the 2714/2715 (see Figure 2-47). If necessary, connect the input signal to the 2714/2715, then choose the OK command button to continue. (The Cancel command button will stop the measurement and return you to the spreadsheet.)

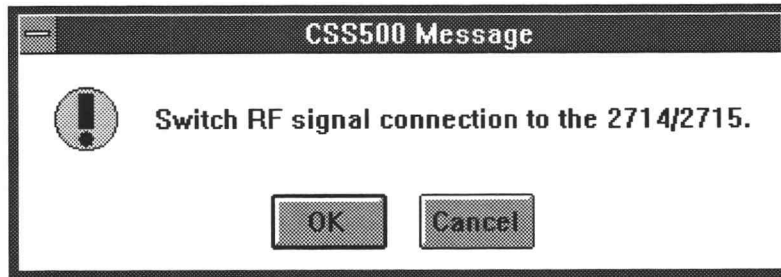

Figure 2-47: Prompt to connect the input signal to the 2714/2715

The software pauses at the next channel, as shown in Figure 2-48.

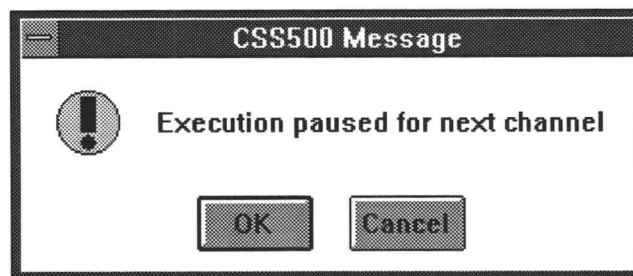
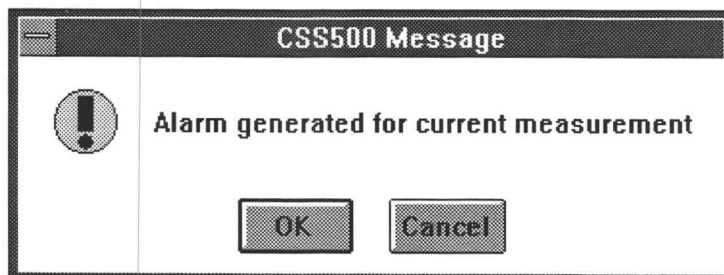

Figure 2-48: Message box stating that the measurements are paused.

3. If necessary, tune the preselector to the channel, then choose the OK command button to continue. If any of your measurement results fall into the Alarm range, Figure 2-49 is displayed.



**Figure 2-49: The message box displayed when a measurement result falls into an Alarm range**

4. Choose the OK command button to continue making measurements. (You have another option. You could choose the Cancel command button to stop making measurements and handle the measurement alarm.) When the measurements are finished with the first channel, the Paused for Next Channel message is displayed, as shown in Figure 2-50.

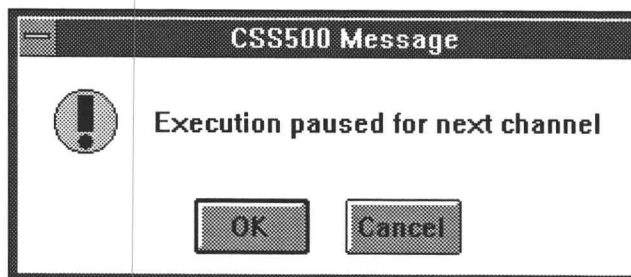

**Figure 2-50: Message box stating that the measurement is paused**

5. If necessary, tune the preselector, then select the OK command button to finish making the measurements.

## Review

Now that you have completed this chapter you should be able to do the following:

- Pick and set up the correct demodulator. (page 2–39)
- Review the RS-232 and GPIB connection setups. (page 2–40)
- Set how measurements are made. (page 2–41)
- Set the measurement setups for the 271X. (page 2–42)
- Set the TDC-10 controls. (page 2–43)
- Set the correct location of the VITS. (page 2–47)
- Change to a different Channel Table. (page 2–49)
- Select whether or not to collect history. (page 2–52)
- Select the Power Level Units. (page 2–54)
- Turn on or off the user prompts. (page 2–54)

# Advanced Measurements Tutorial

This chapter deals with advanced measurement and display topics:

- Viewing the history of a measurement
- Copying data to other Windows applications
- Viewing violations
- Using the various View Filters
- Changing and defining limits
- Defining a User Defined Program (UDP)
- Loading the results of a UDP back into the application

## Reset the Preferences and Worksheet for this Chapter

1. Make a new worksheet and call it “example.wrk”. (Overwrite any old worksheets.)
2. From the Configure menu, choose Preferences. Set Preferences to:
  - Collect History
  - dBmV Carrier Amplitude Units
  - No Prompt for Signal Connection (unless necessary for your equipment setup)
  - No Pause on New Channel (unless necessary for your equipment setup)
  - No Pause on Alarms, Cautions, or Errors
3. From the Configure menu, choose Measurement Setups. Make the appropriate selections for your system.
4. From the Configure menu, choose Worksheet Info. Select the std.cht Channel Table (or other appropriate Channel Table). Select a Site name. (The examples use Tektronix – Beaverton.)

### Make Measurements to Collect History

1. Select the first two channels’ Hum/LFD and FCC Baseband.
2. From the Measure menu, choose Current Selection or choose Meas Sel from the Button Bar.

- Repeat three or four times to collect history for these measurements.

## Results Detail Display

We have collected some history and are ready to view the Results Detail display.

Enter the Results Detail Display for your first channel HUM/LFD:

- Select the Hum/LFD cell of your first channel.
- Choose the Results command button on the Button Bar; or click on the cell with the right mouse button; or, from the View menu, choose Results Detail. The Results Detail dialog box is shown in Figure 2-51.

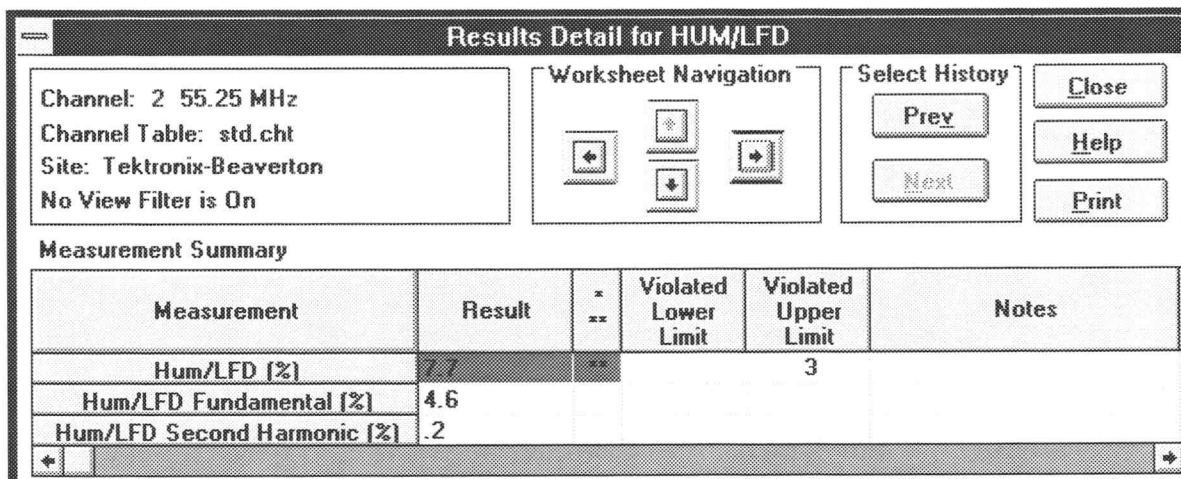

Figure 2-51: The Results Detail dialog box for the HUM/LFD measurement

Note that the Select History Next command button is gray but the Prev button is black. This indicates that you are looking at the most recent measurement results and there is history on that measurement.

- Scroll the Results Detail dialog box horizontally to display the Date/Time and Test ID. Note the time of the measurement.
- Scroll back to the far left of the Results Detail dialog box.

### Look at the History of this Measurement

- Choose the Prev command button. Note that this information is from the previous time you made this measurement. Confirm this by scrolling horizontally to the Date/Time column.
- Choose the Prev command button again.



3. Repeat until the Prev command button is gray. You are now at the first measurement for this cell on this worksheet.
4. Choose the Next command button until you are back to the most recent measurement. (The Next command button is gray.)

### Move Around in the Results Detail Display

You use the Worksheet Navigation arrows to move between channels and measurements without leaving the Results Detail Display.

1. Move to the FCC Baseband measurement for your first channel by choosing the right Worksheet Navigation arrow. Note that the Title Bar of the dialog box changes to reflect the different measurement. The Results Detail display is shown in Figure 2–52.

Channel: 2 55.25 MHz  
Channel Table: std.cht  
Site: Tektronix-Beaverton  
No View Filter is On

Worksheet Navigation

Select History

Close  
Help  
Print

Prev  
Next

Measurement Summary

Measurement	Result	- **	Violated Lower Limit	Violated Upper Limit	Notes
Chroma-Lum Delay [nS]	-74.5				
Chroma-Lum Gain [%]	26.8	**	93		
Differential Gain [%]	16.93	*		10	
Differential Phase [Deg]	-44.38	**	-10		

Figure 2–52: The Results Detail dialog box for the FCC Baseband measurement for the first channel

2. Move to the FCC Baseband measurement for your second channel. Choose the Worksheet Navigation down arrow. Note that the channel number changes.
3. Move to the Hum/LFD measurement for your second channel. Choose the Worksheet Navigation left arrow.
4. Move back to where you started (Hum/LFD for the first channel). Choose the Worksheet Navigation up arrow.

---

**NOTE.** *The equipment making the measurements places the information that you see in the Notes Field. Please see Notes under Measurement Summary on page 3–33 for how to decode this information.*

---

5. Choose Close to leave the Results Detail Display and return to the worksheet.

---

**NOTE.** *The active cell in the worksheet is the last cell navigated to in the Results Detail Display.*

---

## Status Report and View Violations Displays

The Status Report is available to give an impression for how the system is doing as a whole. The Status Report lists all of the measurements and channels with the worst measurement results (based on the active View Filter). The Violations Display is available from the Status Report and it lists all of the measurement Cautions and Alarms.

1. Make all of the measurements for the first three channels. The worksheet looks like Figure 2–53.

---

**NOTE.** *In older 2714 firmware versions, anytime you are making a CSO measurement, a message that the 2714 is executing a CTB measurement appears on the 2714's display. Although unexpected, it is correct and only an artifact of the method that older firmware versions of the 2714 use to measure CSO.*

---

Tektronix – CSS500

File Edit View Measure Configure Execute Help

Open Save Global Results Status Meas Sel Meas Seg Test ID Setups Limits Print

Worksheet: <untitled> Site: Tektronix-Beaverton View Sequence Filter is On  
Chan Table: std.cht Test ID: test 43:16:35

	Visual Carrier Lev (dBmV)	Visual Carrier Freq (MHz)	Aural Carrier Lev (dBc)	Aural Frequency Offset (MHz)	FCC Baseband	Waveform Distortion	Multibur
2 55.25	-9.9	55.289151 **	-32.3 **	4.51235 **	ALARM **	ALARM **	ALARM **
3 61.25	32.5	61.292711 **	-15.9 *	4.504287 *	ALARM **	ALARM **	ALARM **
4 67.25	69.7	67.549817 **	-15.5 *	4.495698 *	ALARM **	ALARM **	ALARM **

Figure 2-53: The worksheet after making all of the measurements for the first three channels

- To display the Status Report choose either the Status button from the Button Bar or Status Report from the View menu. This displays the Status Report dialog box as shown in Figure 2-54. The measurements are in the same order as they are in the spreadsheet with the addition of the Visual Carrier Level (Adjacent) results. The worst case is listed for each measurement.

Status Report

Channel Table: std.cht  
Site: Tektronix-Beaverton  
No View Filter is On

View Results Detail View Violations  
Close Help Print  
 Include History

Measurement Summary

Channel	Measurement	Type	Result	Violated Lower Limit	Violated Upper Limit
6	Visual Carrier Level (dBmV)	Max	69.1		
5		Min	-2.7		
6, 5	Visual Carrier Level Diff. (dB)	Max-Min	71.8	**	10
5, 6	Visual Carrier Level Adj. (dB)	Max	71.8	**	3
3	Visual Carrier Frequency (MHz)	Max Dev	61.397963	**	61.275
2	Aural Carrier Level (dBc)	Max	-26	**	-17
6		Min	-35.2	**	-17
6	Aural Frequency Offset (MHz)	Max Dev	4.480187	**	4.495

Figure 2-54: The Status Report dialog box

- Choose the View Violations display command button to see all of the measurement results that are either in Caution or Alarm states. (See

Figure 2–55.) The Violations are first sorted by Alarms and Cautions (Alarms first), then by channel number (same order as the spreadsheet), and finally by the measurements. In the View Violations dialog box shown in Figure 2–55, all of the measurement alarms for channel 2 are first, then channel 3, and so forth. From the View Violations dialog box, you can go to the Results Detail display.

Channel	Measurement	Result	z **	Violated Lower Limit	Violated Upper Limit
2	Aural Carrier Level (dBc)	-26	**	-17	
2	Aural Frequency Offset (MHz)	4.515838	**		4.505
3	Visual Carrier Frequency (MHz)	61.397963	**		61.275
3	Aural Carrier Level (dBc)	-33	**	-17	
3	Aural Frequency Offset (MHz)	4.514358	**		4.505
4	Aural Carrier Level (dBc)	-27.8	**	-17	
4	Aural Frequency Offset (MHz)	4.480599	**	4.495	
5, 6	Visual Carrier Level Adj. (dB)	71.8	**		3
5	Visual Carrier Frequency (MHz)	77.168671	**	77.225	
5	Aural Carrier Level (dBc)	-34.1	**	-17	
5	Aural Frequency Offset (MHz)	4.486636	**	4.495	
6, 5	Visual Carrier Level Diff. (dB)	71.8	**		10
6	Visual Carrier Frequency (MHz)	83.217415	**	83.225	
6	Aural Carrier Level (dBc)	-35.2	**	-17	
6	Aural Frequency Offset (MHz)	4.480187	**	4.495	
2	Visual Carrier Frequency (MHz)	55.237924	*	55.245	
4	Visual Carrier Frequency (MHz)	67.258121	*		67.255

Figure 2–55: The View Violations display

4. Go to the Results Detail display for your first measurement in the View Violations dialog box. (In this case it is Aural Carrier Level for Channel 2.)
5. Place the cursor somewhere in the first row.

6. Either double-click the left mouse button in that cell, single-click with the right mouse button, or choose the View Results Detail command button (see Figure 2-56.) This is the same Results Detail display that you would access by selecting that channel and measurement cell from the spreadsheet and then either clicking the right mouse button or choosing the Results command button from the Button Bar.

**Results Detail for Carrier Levels and Frequencies**

Channel: 2 55.25 MHz  
 Channel Table: std.cht  
 Site: Tektronix-Beaverton  
 No View Filter is On

**Worksheet Navigation**

**Select History**

Close  
 Help  
 Print

Prev  
 Next

**Measurement Summary**

Measurement	Result	- --	Violated Lower Limit	Violated Upper Limit	Notes
Visual Carrier Level [dBmV]	36.8				
Visual Carrier Frequency [MHz]	55.237924	*	55.245		
Aural Carrier Level [dBc]	26	**	-17		
Aural Frequency Offset [MHz]	4.515838	**		4.505	
2nd Aural Level [dBc]					
2nd Aural Frequency Offset [MHz]					

Figure 2-56: The Results Detail display

7. Close this display and return to the View Violations display.
8. Close the View Violations dialog box. You are now back to the Status Report. Notice that you can enter the Results Detail display from this dialog box.
9. Enter the Results Detail display for your first entry in the Status Report. (Place the cursor anywhere in the first row. Either double click with the left mouse button, single click with the right mouse button, or choose the Results Detail command button to enter the Results Detail Display.)
10. Close the Results Detail display. You are back to the Status Report.
11. Close the Status Report and return to the spreadsheet.

### Quick Summary of the Status Report and View Violations

The Status Report and View Violations display are two nested reports or measurement summaries of what is going on in the worksheet. Either can access the Results Detail display for any measurement result of interest.

Print any of these by choosing the Print command button from the dialog box.

The View Filter also affects these displays. (See page 2–73 for more information on the View Filter.)

If the Include History check box is selected, the results include all of the measurement results collected. If it is not checked, then only the most recent measurement results are included.

You know how to collect measurement results and one way to display history. What if you want to take results that you have collected and use them for reports or to graph trends? You can transfer the data to other programs such as Excel or Word, through either the Copy or Export commands.

## Copy and Export

Copy and Export are the two ways of getting data out of the spreadsheet and into other Windows applications for additional processing or to include information in reports. Copy moves the data to the Windows Clipboard, while Export saves the data as a results (\*.wsr) file.

### Copy to the Clipboard

There are many reasons why you might want to move a few cells of data from the CSS500 application into some other Windows application. You might want to average some of the measurements or make a graph of some channels that seem to be deteriorating or paste them into a report. The easiest way of getting a few cells of data is to copy them to the Clipboard using Copy from the Edit menu.

#### Copy Cells to the Clipboard

1. Select the Carrier to Noise cell for the first channel and make that measurement several times.
2. With that cell still selected, from the Edit menu, choose Copy. The Copy dialog box appears as shown in Figure 2–57.

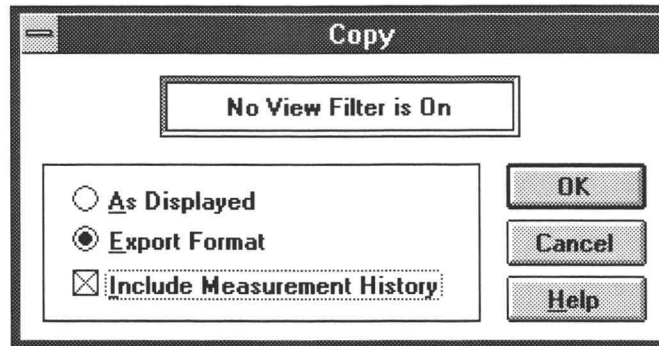

Figure 2-57: The Copy dialog box

3. Select the Export Format option button and the Include Measurement History check box.
4. Select the OK command button. The information from the spreadsheet is copied to the Clipboard.

### Paste the Clipboard Data into Excel

1. Use Switch To, from the CSS500 Control Box, to start the Excel application. (Either go to the Program Manager to start it or go to Excel directly if it is already running.)
2. Select the first cell in the Excel sheet.
3. From the Excel Edit menu, choose Paste. This loads the new data into the sheet. (You may need to change the format width of the columns in order to read the data.) The resulting spreadsheet looks similar Figure 2-58.

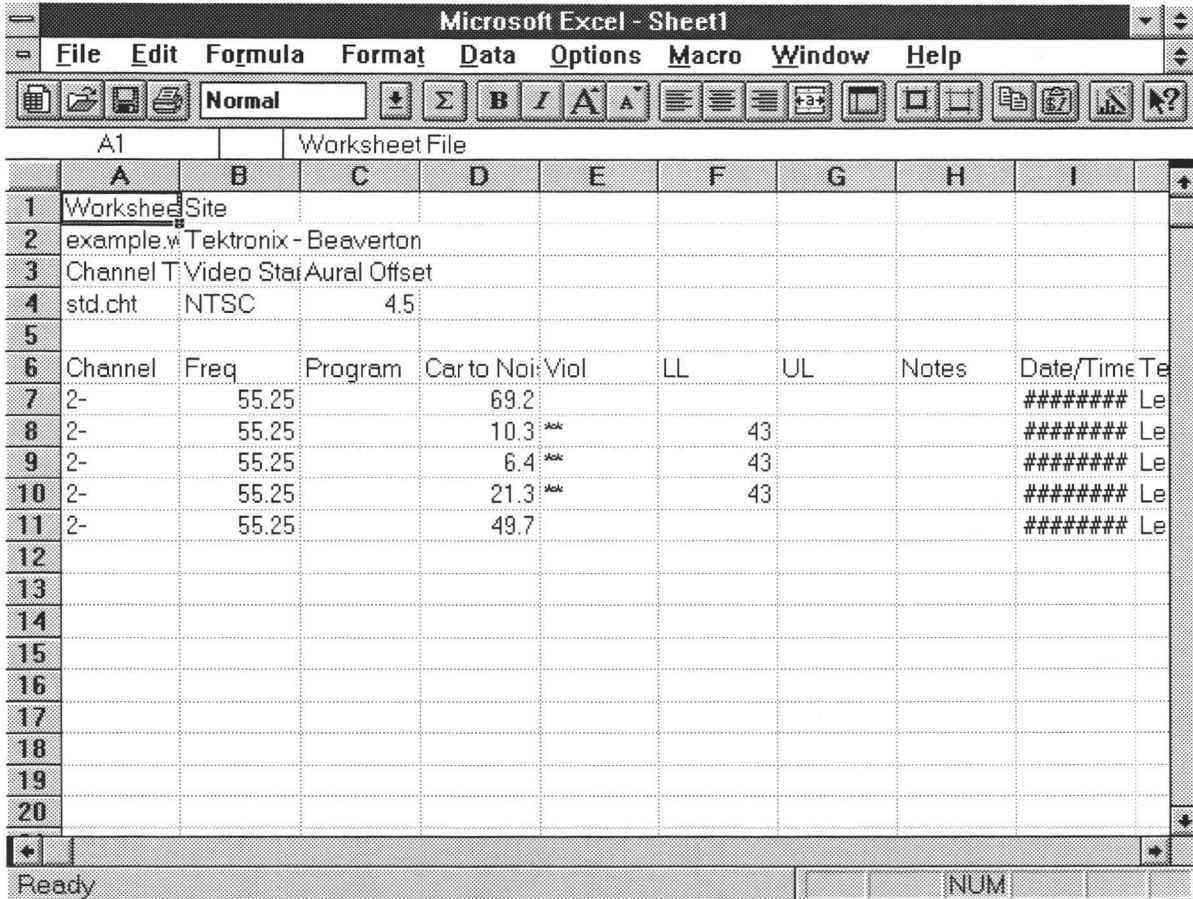

Figure 2-58: The results of pasting the Clipboard data into Excel

4. Use Switch To, from the Excel Control Box, to return to the CSS500 application.

---

**NOTE.** If you try to copy an entire row filled with measurements into Excel, the operation will fail, there are more columns than Excel can handle. It is strongly suggested that you separate the Audio measurement results and put them in a different Excel file.

---

**Use the Copy As Displayed Format.** There is a difference between copying data As Displayed and in Export Format. The As Displayed format will not copy any history or header information such as Site or Test ID. In this format, only the Measurement and Channel Header information follow the cell data. This is useful if you only want to process the data and don't want any additional information.



1. Select the Carrier to Noise cell for the first four channels and make some measurements.
2. With those cells still selected, choose Copy from the Edit menu. The Copy dialog box appears as shown in Figure 2–59.

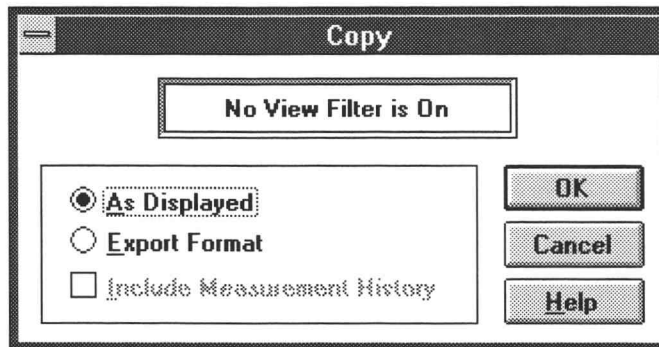

Figure 2–59: The Copy dialog box

3. Select the As Displayed option button.
4. Choose the OK command button. The information from the spreadsheet is copied to the Clipboard.

### Paste the Clipboard Data into Excel

1. Switch to the Excel application.
2. Select a cell in the spreadsheet.
3. From the Edit menu, choose Paste. This loads the new data into the spreadsheet. Figure 2–60 shows the results. Notice the differences between the two spreadsheets (see Figure 2–58 and Figure 2–60).

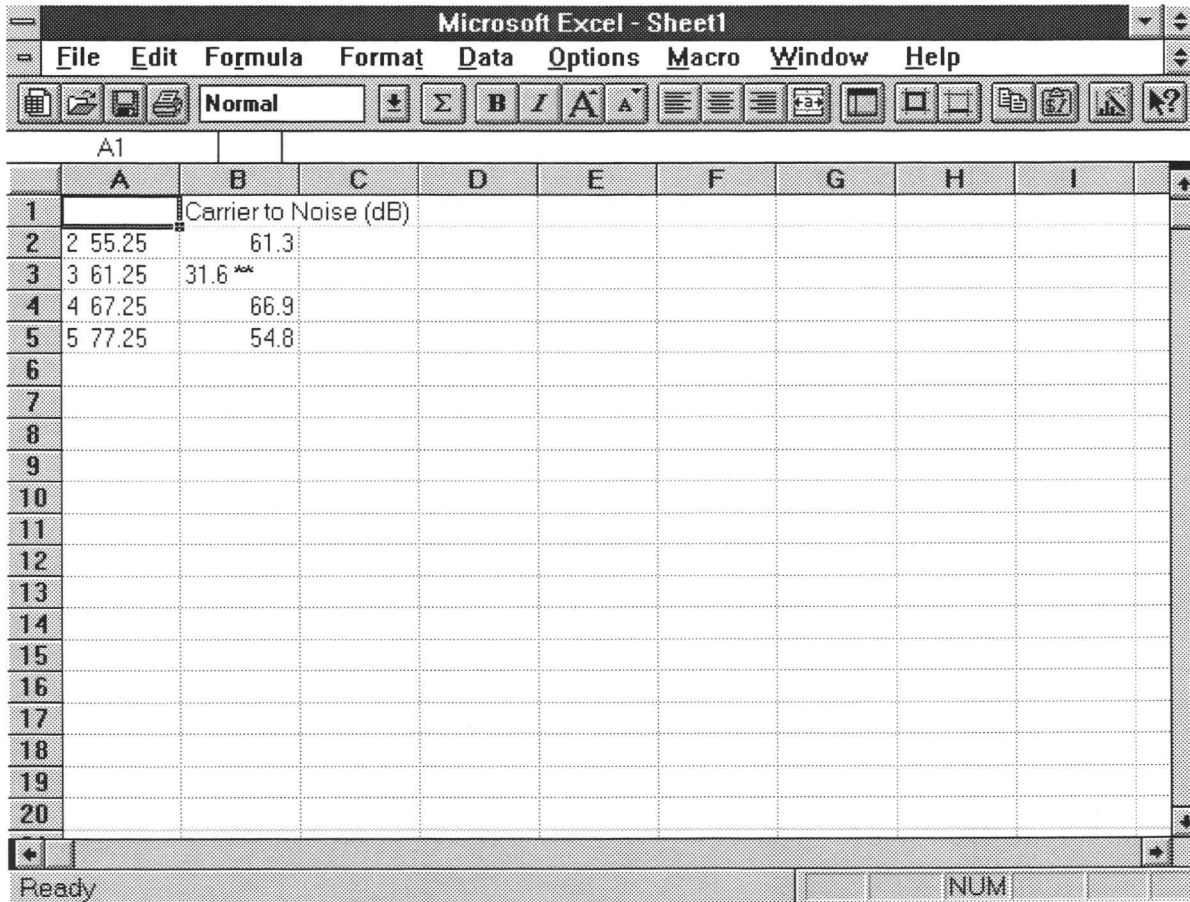
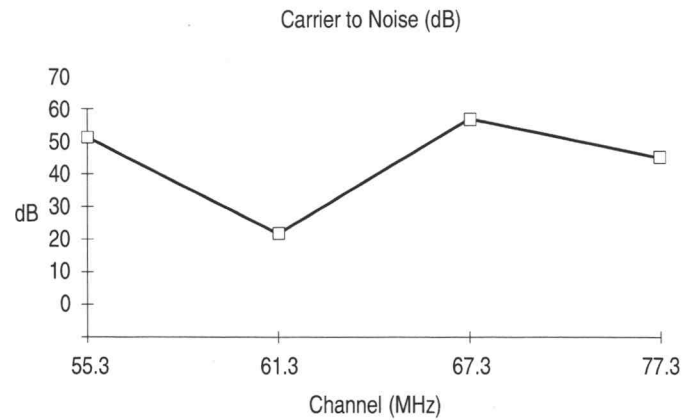

Figure 2-60: The result of the Copy As Displayed pasted into Excel

4. Use Excel to make a graph of the measurement results' trend, similar to the one shown in Figure 2-61.



**Figure 2-61: Data for the Carrier to Noise Ratio for four channels**

5. Switch back to CSS500.

### Using Export

Use Export when you want to save the results to a file instead of just to the clipboard. This is useful for archiving the measurement results without needing to save all of the files necessary to archive an entire worksheet.

1. Select the desired cells.
2. From the File menu, choose Export. The Export dialog box looks similar to Figure 2-62.

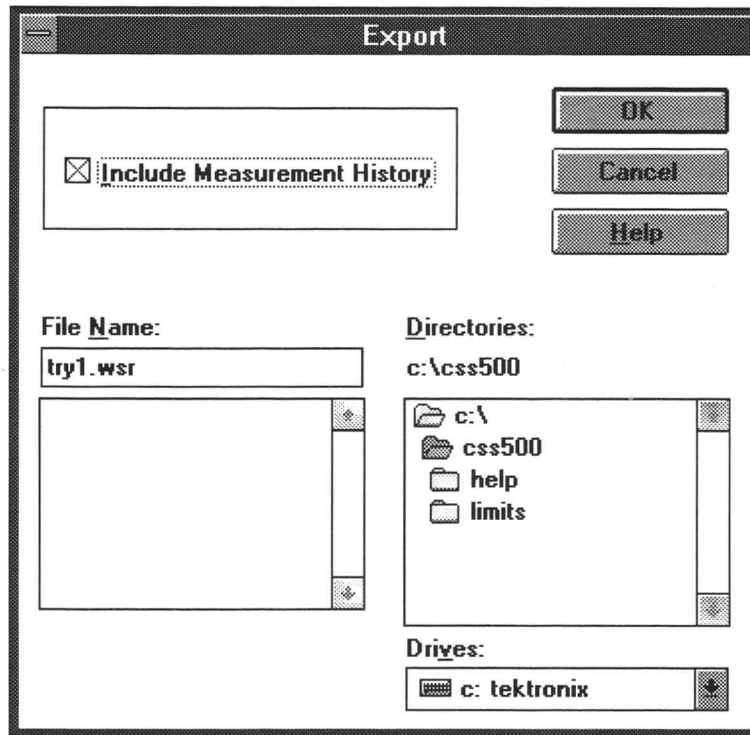

Figure 2-62: The Export dialog box

3. The worksheet name with a “.wsr” extension is automatically inserted in the File Name combo box. If you want a different filename, type it in the combo box.
4. Select Include Measurement History.
5. Choose the OK command button to export the data to a file.

---

**NOTE.** You cannot import a \*.wsr file into Excel. It has more columns than Excel supports. If you want to load data into Excel, use Copy — Export Format and select only a few measurement columns at a time.

---

6. Clear the worksheet (including history) to be ready for the next exercises.

## View Filters

There may be times when you do not want to see the entire list of measurements and channels on the spreadsheet, rather only the few that you are working with at the moment. You can simplify the spreadsheet down to only the interesting cells, through the use of three View Filters. They are: Measurements and Channels, Sequence Results, and Test ID. These filters hide any measurements results that you are not currently interested in. The View Filters affect most of the other displays such as Global View and Results Detail. These displays only show the same measurement results as the main spreadsheet.

The View Filter affects Copy operations; if you cannot see it, you cannot select it. Export always sends the entire worksheet to the \*.wsr file, regardless of the View Filter Status.

Only one View Filter can be on at a time and the filter that is on is displayed in the View Filter Status Box in the Worksheet Header.

If a View Filter is on, many other operations are locked out. For example, if Measurement Sequence View Filter is on, Meas Sel from the Button Bar is unavailable.

### Measurements and Channels View Filter

Set the View Filter so that only the first four measurements for the first two channels are in view.

1. Select the Carrier Level and Frequency measurements for the first two channels. Make the measurements.
2. From the View menu, choose Measurements and Channels. The Measurements and Channels dialog box appears as shown in Figure 2-63.

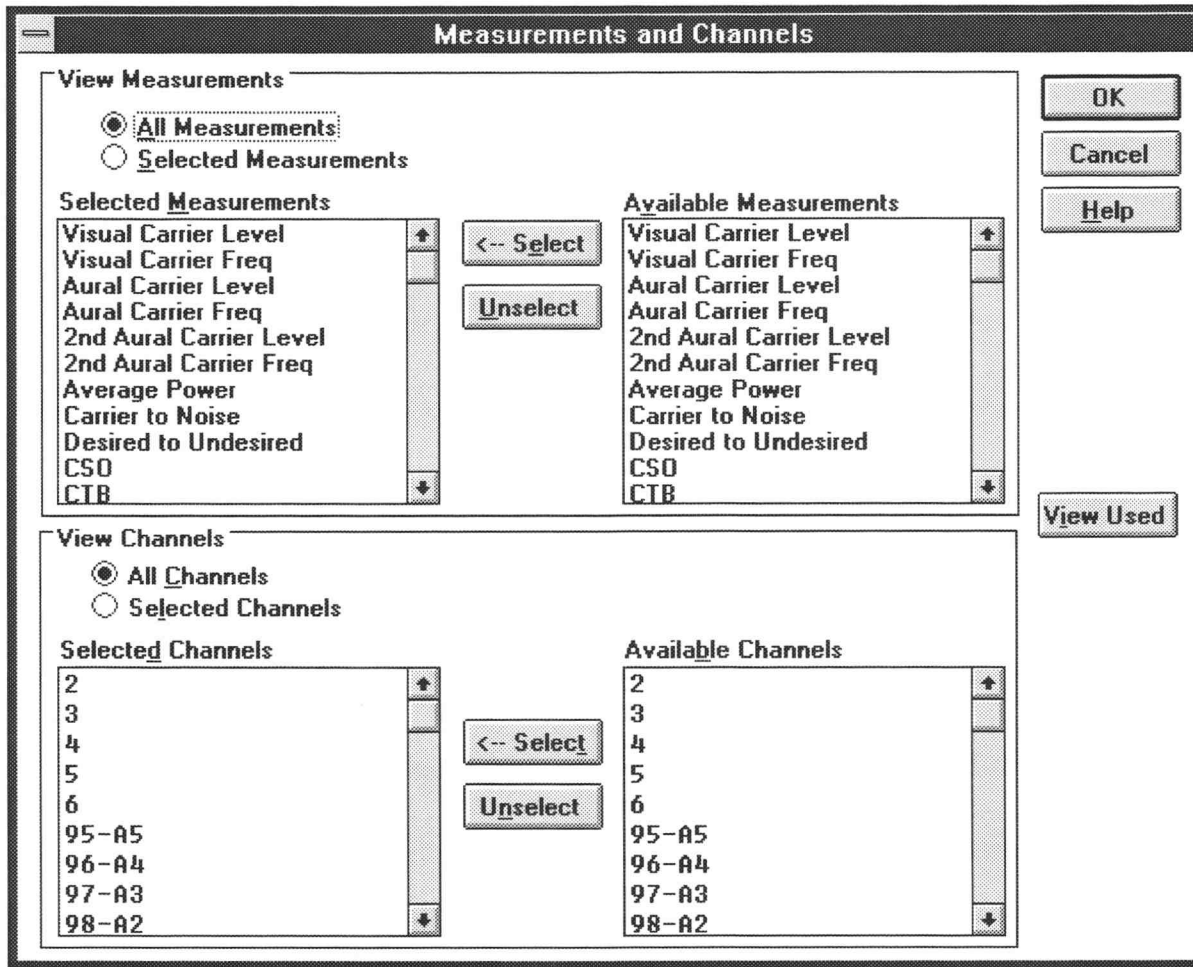

Figure 2-63: Measurements and Channels View Filter dialog box

3. Under the View Measurements group, select the Selected Measurements option button.
4. Select everything except Carrier Levels and Frequencies (Visual Carrier Level, Visual Carrier Frequency, Aural Carrier Level, and Aural Carrier Frequency) from the Selected Measurements list box. (Hint: select 2nd Aural Carrier Level, then scroll to the bottom of the list. Hold down the SHIFT key and click on the last measurement.)
5. Choose the Unselect command button to remove all of these measurements. (The only measurements left in the Selected Measurements list box are Carrier Levels and Frequencies.)
6. Under the View Channels group, select the Selected Channels option button.

7. Select everything except the first two channels from the Selected Channels list box.
8. Choose the Unselect command button to remove these channels. (Only the first two channels, 2 and 3, remain in the Selected Channels list box.) The Measurements and Channels dialog box now resembles Figure 2-64.

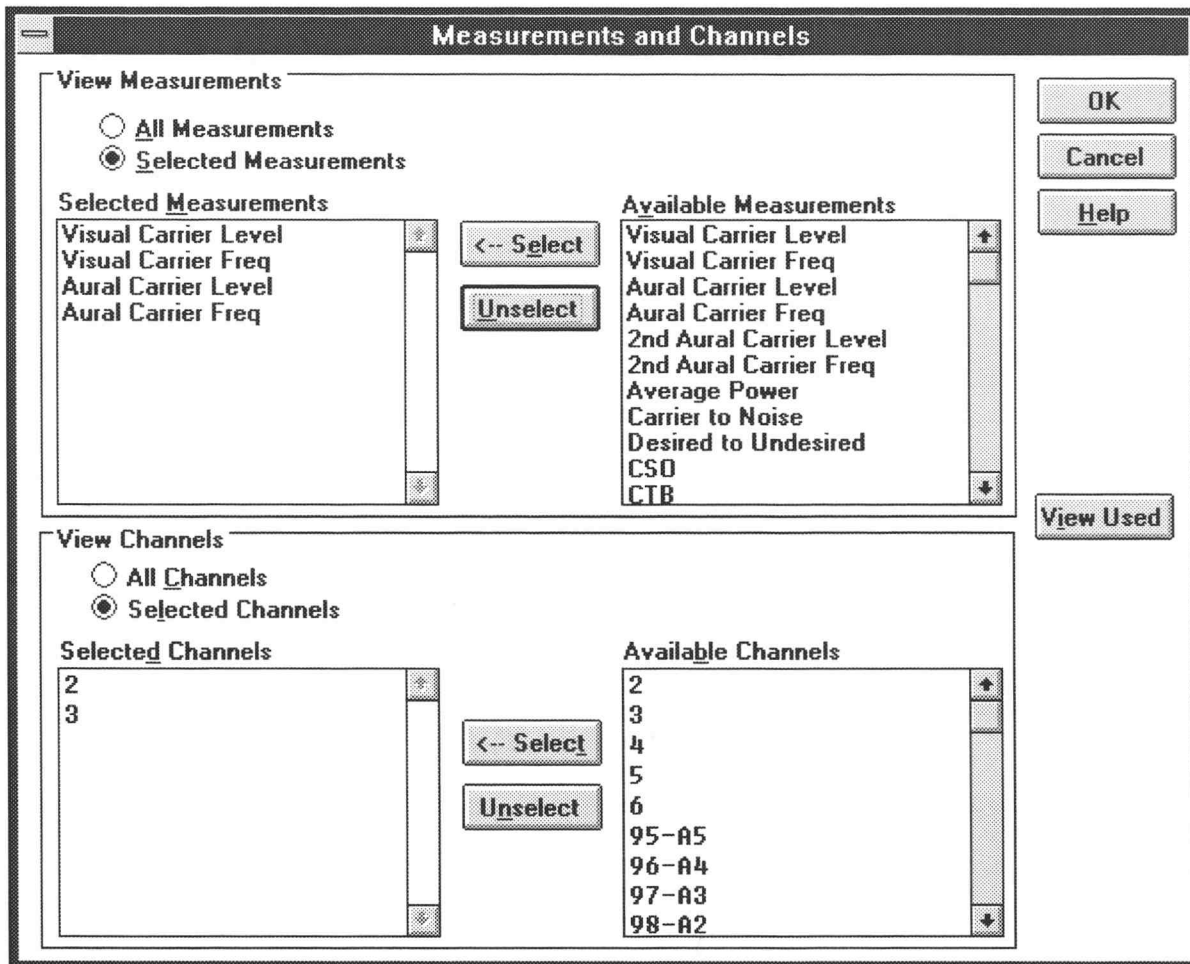

Figure 2-64: The Measurement and Channels dialog box

9. Choose the OK command button to save the changes and leave the dialog box. The spreadsheet looks similar to the one shown in Figure 2-65.

	Visual Carrier Lev (dBmV)	Visual Carrier Freq (MHz)	Aural Carrier Lev (dBc)	Aural Frequency Offset (MHz)
2 55.25	17.2	55.175538 **	34.9 **	4.513093 **
3 61.25	48.7	61.484684 **	-14.3 *	4.506024 **

Figure 2-65: The Spreadsheet with the Measurement and Channels View Filter on

**NOTE.** Notice that although the first six measurements are tied together under most circumstances, the View Filter allows them to be viewed separately. If you request one of these measurements, CSS500 will try to make all six even if they are not in view. (It cannot make the Second Aural Measurements if they are not enabled in the Channel Table.)

10. Return to the full spreadsheet. From the View menu, choose Measurements and Channels. The view automatically switches back to the full display. You can toggle between the filtered and full view by selecting/deselecting Measurements and Channels from the View menu.

**Measurement Sequence Results View Filter**

If you only want to see the results from the last Measurement Sequence, use the Measurement Sequence Results View Filter. At the end of every Measurement Sequence execution you are prompted if you want this filter turned on.

For example: define a Measurement Sequence, run it, and then display only its results using the View Filter.

1. Clear the present spreadsheet. (From the Edit menu, choose Select All. Then from the Edit Menu, choose Clear and select the check boxes to delete Current Values and Measurement History.)
2. From the Configure menu, choose Measurement Sequence. (You are now in the Measurement Sequence dialog box.)
3. Choose the Clear Sequence command button to clear the Measurement Sequence.



4. Select the following measurements for the first four channels:
  - Carrier Levels and Frequencies
  - FCC Baseband
  - Waveform Distortion
  - Multiburst
5. Choose the Edit Time Parameters command button. (You are now in the Edit Time Parameters dialog box.)
6. Select the Run Immediately check box and make sure that the Run Continuously check box is not checked.
7. Choose the OK command button to save the changes and leave the Edit Time Parameters dialog box. (You are back to the Measurement Sequence dialog box.)
8. Choose the OK command button save the changes and leave the Edit Measurement Sequence dialog box. (You are back to the spreadsheet.)
9. Select the Meas Seq command button on the Button Bar to run the Measurement Sequence. At the end of the Measurement Sequence, a dialog box similar to Figure 2-66 is displayed.

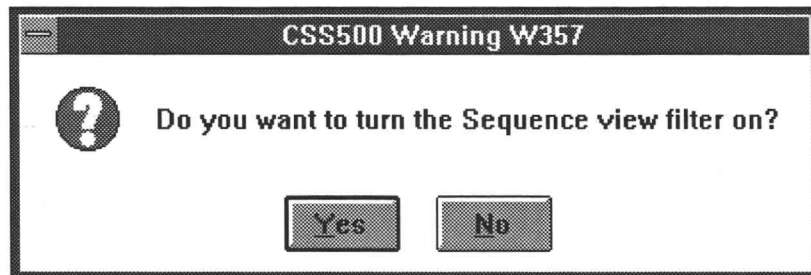

**Figure 2-66: The prompt to turn on the Measurement Sequence Results filter given at the end of a Measurement Sequence**

10. Choose Yes to turn on the Measurement Sequence View Filter. The spreadsheet looks similar to the one shown in Figure 2-67. Notice that there are no Second Aural measurements. They are not enabled in this Channel Table.

	Visual Carrier Lev [dBmV]	Visual Carrier Freq [MHz]	Aural Carrier Lev [dBc]	Aural Frequency Offset [MHz]	FCC Baseband	Waveform Distortion	Multibur
2 55.25	-9.9	55.280151 **	-22.3 **	4.51235 **	ALARM **	ALARM **	ALARM **
3 61.25	32.5	61.292711 **	-15.9 *	4.504287 *	ALARM **	ALARM **	ALARM **
4 67.25	69.7	67.549817 **	-15.5 *	4.495698 *	ALARM **	ALARM **	ALARM **

Figure 2-67: The spreadsheet with the Measurement Sequence Results filter turned on

- Turn off the Measurement Sequence Results filter. From the View menu, choose Measurement Sequence Results. This toggles the View Filter off. You are back to the standard spreadsheet display.

**NOTE.** If you went in and defined a new Measurement Sequence and ran it, then turned on the Measurement Sequence Results filter, you will see only the results from the last Measurement Sequence — not the old one.

### Test ID Results View Filter

There are times when you only want to see a subset of the measurements made at a particular site. This is when the Test ID Results View Filter is useful. For example, if Pre-Converter and Post-Converter measurements are made under different Test IDs, then they can be viewed separately using the Test ID Results View Filter.

You have been operating under the Test ID “Learner’s Permit.” Now change your Test ID, make a few measurements under that ID, and look at the results using the Test ID View Filter.

- Choose the Test ID command button on the Button Bar.
- Type: “Training Wheels” in the text box.
- Choose the OK command button.
- Select the ICPM measurement for the first four channels.
- From the Measurement menu, choose Current Selection.

- From the View menu, choose Test ID Results. The results should be similar to Figure 2–68.

	ICPM (Deg)
2 55.25	23.5 **
3 61.25	10.9 **
4 67.25	7.2 **
5 77.25	-13.9 **

Figure 2–68: The results of turning on the Test ID Results filter

- Choose the Test ID command button on the Button Bar.
- Display the selection of Worksheet Test IDs and select “Learner’s Permit”. (The Worksheet Test IDs are the Test IDs used in the current worksheet. The other list is all of the Test IDs ever used.)
- Choose the OK command button to save the change and exit the Test ID dialog box. You will only see the measurements that you made under the Learner’s Permit Test ID — not the ICPM measurements.
- From the View menu, choose Test ID Results to turn the View Filter off and return to the normal spreadsheet with measurements collected from both Test IDs displayed.

## Defining Limits

Limits files determine how to characterize your measurement results. Results can be passing, in alarm, in caution, or have no limits defined. You can change the range of these values to suit your own application. In fact, you can have a different set of limits for every channel. For example, the premium and the public access channels may have their own unique Limits files.

**Edit a Limits File** First, enter a Limits file to see the information contained there.



**CAUTION.** When you edit a Limits file, the changes affect all worksheets using that Limits file.

1. Choose the Limits command button on the Button Bar, or, from the Configure menu, choose Measurement Limits. This displays the Measurement Limits dialog box, as shown in Figure 2–69.

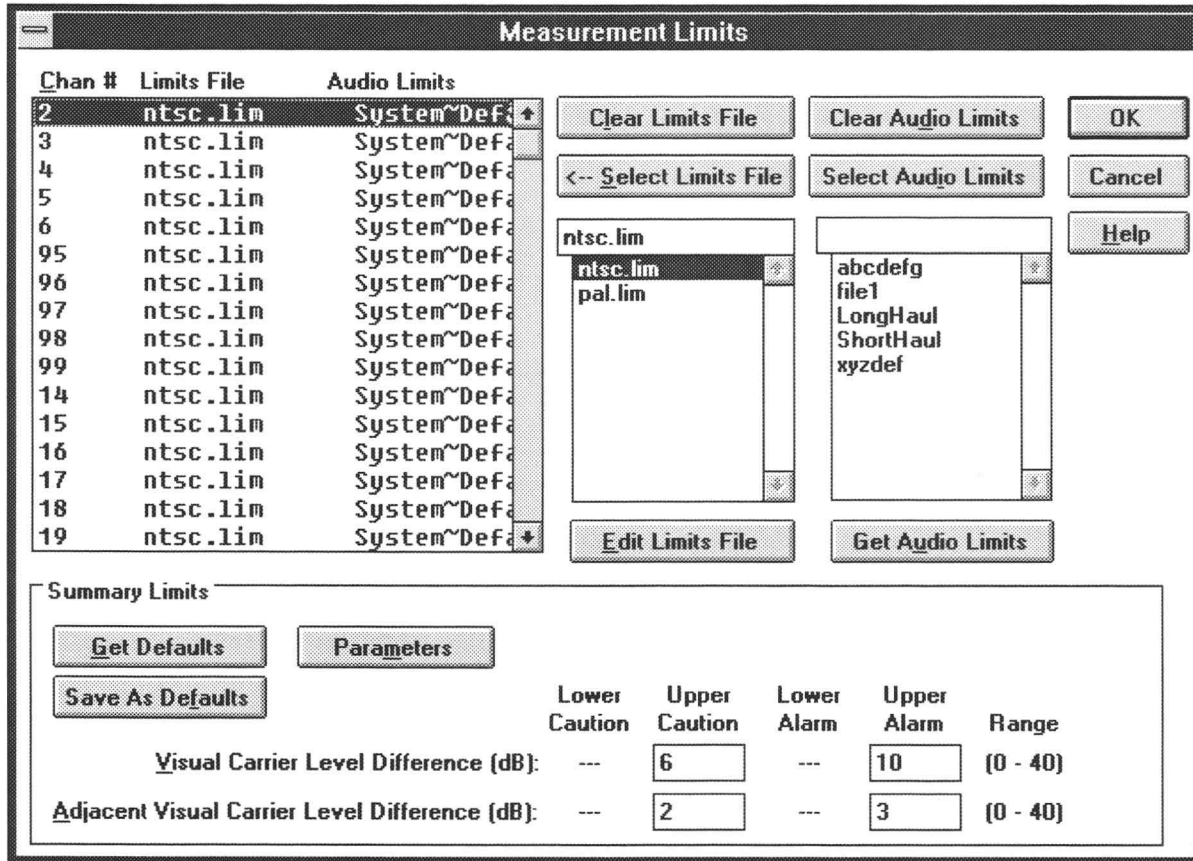

Figure 2–69: The Measurement Limits dialog box

In the present setup, all of the channels have the same Limits file associated with them, “ntsc.lim”. Now take a look at the contents of this file (or whatever Limits file you might like).

2. Select a Limits file from the Limits file combo box (the example uses ntsc.lim).
3. Choose the Edit Limits File command button. Figure 2–70 shows the Edit Limits File – ntsc.lim dialog box.

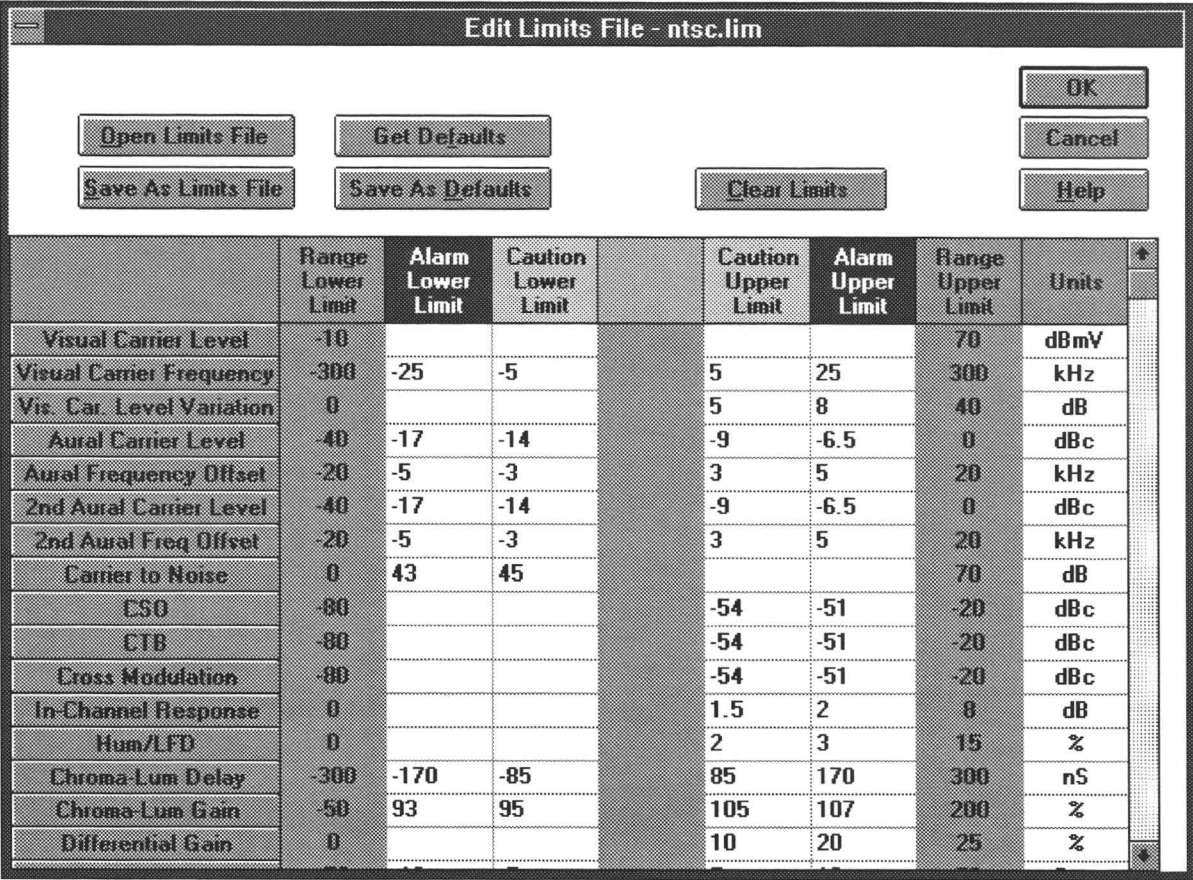
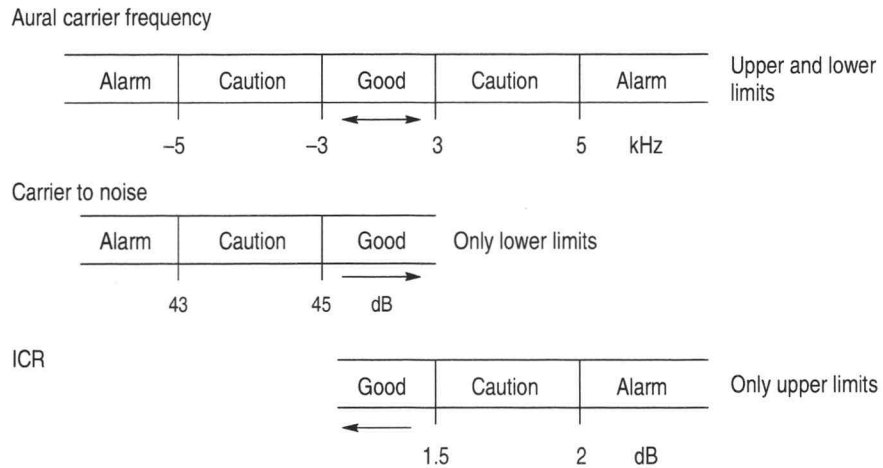

Figure 2-70: The Edit Limits File – ntsc.lim dialog box

Three of the columns (Range Lower Limit, Range Upper Limit, and Units) define the allowable ranges. These columns are not editable. The other four columns define the Alarm and Caution ranges.

The Caution and Alarm columns define the way the measurement results are categorized. See Figure 2-71 for an example of the three types of measurements and the different limits that they require. The Aural Frequency Offset requires both upper and lower limits. The Carrier to Noise Ratio has only lower limits. The ICR has only upper limits.



**Figure 2-71: How limits work**

If you attempt to enter an Upper or Lower Limit outside the ranges defined, you receive an error message (as shown in Figure 2-72) that the value is out of range and are returned to that cell to re-enter an acceptable value.

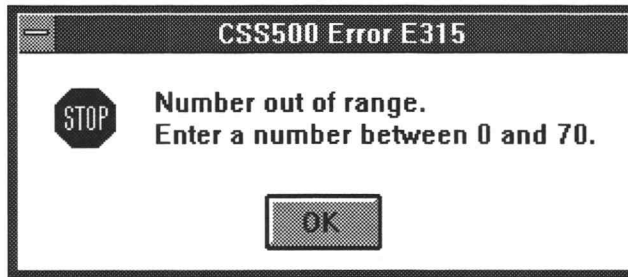

**Figure 2-72: An example of an error message**

You can edit the Alarm and Caution ranges to as tight or loose a specification as desired as long as the value is in the acceptable range and maintains the relationship:

$$\text{Alarm Lower Limit} < \text{Caution Lower Limit} < \text{Caution Upper Limit} < \text{Alarm Upper Limit}$$

Note that there are different measurements in the Limits file depending on the video standard (NTSC or PAL). The video standard is set in the Channel Table.

Practice editing the Limits file by tightening the Alarm and Caution limits on a few measurements and then save it as a new Limits file. (Remember, any change that you make to a Limits file affects all channels and worksheets using that file.)



**CAUTION.** *When you edit a Limits file, the changes affect ALL worksheets using that Limits file.*

### Edit the Limits File

1. Choose the Clear Limits command button. This erases all of the old limit values.
2. Choose the Get Defaults command button. This loads the limit values corresponding to the default Limits file.
3. Select the Visual Carrier Frequency measurement–Caution Lower Limit cell. (Present value is –5 in the example.)
4. Type “–4”. (Values automatically overwrite.)
5. Move the cursor to the Caution Upper Limit cell.
6. Type “4”.
7. Select the Visual Carrier Frequency measurement–Alarm Lower Limit cell.
8. Enter “–20”.
9. Press TAB to move to the Alarm Upper Limit.
10. Enter “20”.
11. Choose the Save As Limits File button to save the file.
12. Save this as a new file.
13. You are prompted for a new name and the cursor is already in the list box. Type in “learners”.
14. Choose the OK command button, to leave the Edit Limits dialog box. You are back to the Measurement Limits dialog box.

### Attach a Limits File to a Channel

1. Select the first channel on the list. (In the example, it is channel 2.)
2. Select your file “learners.lim” from the Limits list box. The selected file appears in the box at the top of the list box.
3. Attach the file to the channel. Either double click on the file name with the left mouse button or choose the Select Limits File command button.

The Limits file for channel 2 is now “learners.lim”.

### Remove a Limits File from a Channel

1. Select your second channel. (In the example, it is channel 3.)

2. Remove the Limits file associated with that file. Choose the Clear Limits File command button. Channel 3 no longer has a Limits file associated with it and the Limits File column is blank. (You know that a measurement has no defined limits when the results are in white cells on the spreadsheet.)

### Return to the Spreadsheet to See the Results

1. Choose the OK command button to save the changes and return to the spreadsheet. Notice that the Alarm and Caution ranges have tightened (and may have changed colors) and that all measurements in the second channel are now in white cells.
2. Choose the Limits command button from the Button Bar to return to the Measurement Limits dialog box.
3. Change your first two channels back to their previous Limits file, "ntsc.lim".
4. Choose the OK command button to save the changes and return to the spreadsheet.

### Audio Limits

Audio Limits are attached to the channels in the same manner as the normal Limits file. There are a few important differences to note. You can only edit the Audio Limits file at the VM700A. Use the Get Audio Limits command button to retrieve Audio Limits from the VM700A and make them available to CSS500. Once a measurement is made using the selected Audio Limits, the measurement results are always tagged with the selected Audio Limits file. For example, you make some audio measurements and they come back in alarm. You go to the VM700A and loosen the Audio Limits file so that the results should now pass. You return to the worksheet and the measurement results are still shown in alarm. For more information on the Audio Limits, see page 3–68.

### Summary Limits Group

The Summary Limits affect all of the channels and are not associated with any particular Limits file. Edit the Visual Carrier Level Difference and the Adjacent Visual Carrier Level Difference like any other text box. Click on the text box and enter a number between 0.0 and 40.0 to set the Alarm and Caution flags.

The results of these limits are not available on the main spreadsheet, but rather in the reports (such as the Status Report and the Measurement Summary for the Carrier Levels and Frequencies).

**Visual Carrier Level Difference.** These calculated results look at the results of the Visual Carrier Level measurements to find the highest and lowest level across all channels. The difference between them is the result.

**Adjacent Visual Carrier Level Difference.** These are calculated results that show the difference in Visual Carrier Level between two channels that are adjacent in frequency.



**NOTE.** If you have a View Filter on so that not all channels are displayed, the calculated results do not comply with FCC requirements, because CSS500 only looks at the displayed channels. Make sure no View Filters are on when you want to check these results.

**Set the Summary Limits.** Choose the Limits command button from the Button Bar. Figure 2-73 shows a portion of the Measurement Limits dialog box.

	Lower Caution	Upper Caution	Lower Alarm	Upper Alarm	Range
Visual Carrier Level Difference (dB):	---	6	---	10	(0 - 40)
Adjacent Visual Carrier Level Difference (dB):	---	2	---	3	(0 - 40)

Figure 2-73: The Summary Limits (located at the bottom of the Limits dialog box)

Edit the text boxes as required.

Choose the Parameters command button to set the window for adjacent channels. This dialog box (see Figure 2-74) defines what constitutes an adjacent channel. Any “adjacent” channels that are outside of this frequency window are not included in the calculations. Select what is required for your system and then choose OK.

Parameters

Adjacent Channel Window: 6.1 MHz

OK  
Cancel  
Help

Figure 2-74: The Parameters dialog box

Choose the OK command button to save the changes to the measurement limits and exit the Measurement Limits dialog box.

## The 2714/2715 User Defined Program (UDP)

There are many times when tests need to be run at a remote location away from the convenience of the computer running the CSS500 application, but you still want incorporate the data into the spreadsheet. The answer is to generate a User Defined Program (UDP). A UDP is basically a Measurement Sequence run on the 2714/2715 at a remote location. When the remote testing is completed, return the results to the CSS500 application and the spreadsheets and reports are very similar to the data collected directly with the CSS500 application. For example: a worksheet is used to generate a UDP for the 2714/2715. The 2714/2715 is removed and taken to various field test locations, using the UDP for measurement results gathering.

Remember that the UDP carries not only the Measurement Sequence instructions, but also much of the header and configuration information. Table 3-7, on page 3-61, gives a complete list. It is important to check the following dialog boxes to make sure that they describe the way that you want the UDP to operate:

- Worksheet Info, from the Configure menu (the Channel Table)
- Test ID
- Measurement Setups, from the Configure menu
- Preferences, from the Configure menu
- Edit Time Parameters (from the Measurement Sequence dialog box)

A good example of a typical UDP is a 24 Hour Test with a few extra measurements specific to your application.

### Define a UDP

The following procedures describe how to define a UDP.

#### Define a Worksheet, Channel Table, and Test ID

1. Choose New from the File menu.
2. In the Description group, type "This worksheet is only for practicing writing and retrieving data from UDPs."
3. Select the std.cht from Channel Table in the list box.
4. Select <undefined> from the Site combo box. (There is no need to define the Site — that information is not transferred to the 2714/2715.)

5. Choose the OK command button to save the changes and return to the spreadsheet.
6. From the File menu, choose Save As.
7. Enter the new worksheet name “remote.wrk”.
8. Choose the OK command button to save the worksheet and return to the spreadsheet.
9. From the Configure menu, choose Test ID.
10. Type “Learner’s Remote” in the text box.
11. Choose the OK command button to save the change and return to the spreadsheet. The Worksheet Header looks similar to Figure 2–75.



Figure 2–75: Worksheet header after being edited for the UDP

### Define the Measurement Setups and Preferences

1. From the Configure menu, choose Measurement Setups.
2. Set the 2714/2715 Power Line Frequency and Preamp option buttons to match your system (at the remote location).
3. Enter the External Attenuation/Amplification in the text box to match the remote location. (The TDC-10 and Zero Carrier Pulse groups do not matter for UDPs since they are only significant for baseband.)
4. Select a channel from the list box, then choose the Edit Setups command button.
5. Make the appropriate selections from the various groups.
6. Choose the OK command button to return to the Measurement Setups dialog box. Repeat as necessary for all channels.
7. Choose the OK command button to save the changes and return to the spreadsheet.
8. From the Configure menu, choose Preferences.
9. Select the Collect history option button.
10. Do not select any of the check boxes.

11. Choose the OK command button to save the changes and return to the spreadsheet.

### Define the Measurement Sequence

1. From the Configure menu, choose Measurement Sequence.
2. Choose the Clear Sequence command button to remove any previous Measurement Sequence.
3. Choose the FCC 24 Hour Test Auto Selection command button.
4. Choose the Create 2714/2715 UDP command button. The dialog box appears as shown in Figure 2-76.

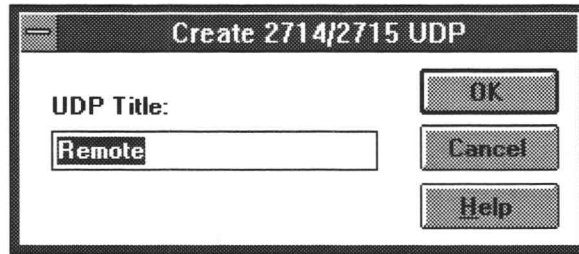

Figure 2-76: The Create 2714/2715 UDP dialog box

5. Enter “Remote” in the text box.
6. Accept this UDP title (the same as the worksheet) by choosing the OK command button. The UDP “Remote” is generated and loaded into the 2714/2715. This title appears in the 2714/2715’s USER DEF menu.
7. The Create 2714/2715 UDP dialog box goes away if the UDP was successful in loading; if it fails an error message appears. The most common error is having more than nine UDPs defined in a single instrument. At the instrument, delete one or more UDPs and then try again.

### Run the UDP

1. Take the 2714/2715 to the remote location and connect it to the test point.
2. Define the 2714/2715 SITE parameter. “Beaverton – Remote 1” is the example. The Site name is not defined in the UDP, therefore it must be done on location in the 2714/2715.
3. Execute the UDP using the 2714/2715 front panel keys (see the 2714/2715 “USER DEF” menu). Allow the 2714/2715 to run until all measurements are collected. (This will take 24 hours to complete – but it can be stopped after one iteration.)

Now that you have gathered the data, it needs to be loaded back into a CSS500 worksheet.

## Get Stored Results from the 2714/2715

This menu item retrieves all the measurement results currently stored in the NVRAM of the connected 2714/2715. The results are not erased from the 2714/2715 memory after they are retrieved. Results are only erased using specific 2714/2715 front panel keystrokes. It is a good practice to always Import into a new worksheet or one set up specifically for importing, so that no information in the current worksheet is inadvertently overwritten.

1. From the File menu, choose Open.
2. Select the remote worksheet used to define the UDP.
3. Choose the OK command button.
4. From the Measure menu, choose Get Stored Results from the 2714/2715. Figure 2-77 shows the dialog box.

Within the dialog box, the results are grouped according to Site and Channel Table name. Ordering within the directory is alphabetical by site name. Count is the actual number of measurement results contained in the group specified by the Site and Chan Table columns. Results File is the name of the results file to which a particular group of results has been exported.

Note that in Figure 2-77 there is no results file for the selected site. This is because the data has not yet been exported to a results file. Before results can be imported into CSS500 it must first be exported into a \*.wsr file.

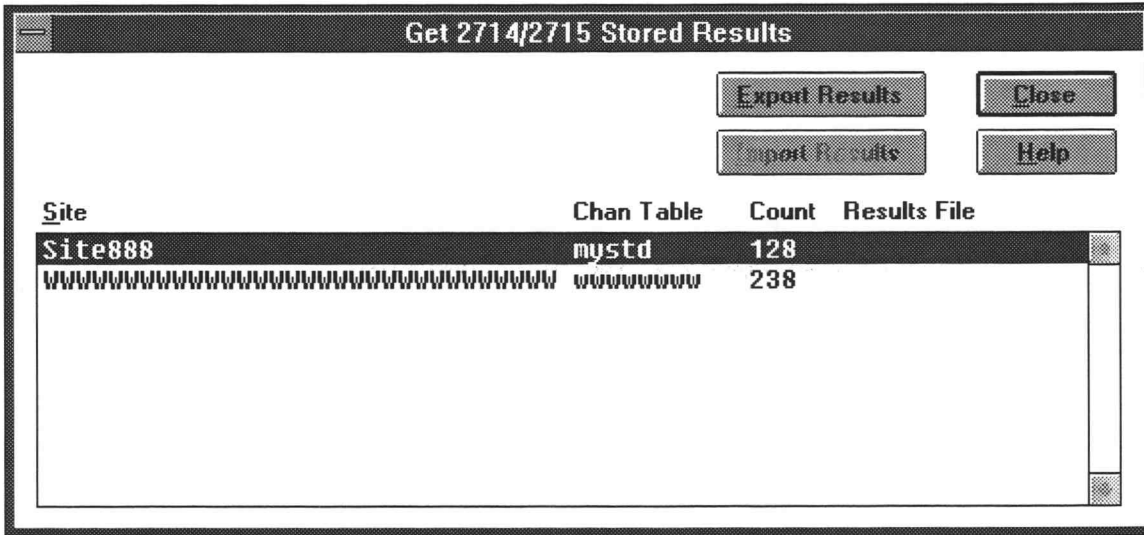

Figure 2-77: The Get Stored Results dialog box.

5. Choose the Export Results button to export some results (the example uses Site 888) into a \*.wsr file. Figure 2-78 shows the Export dialog box.

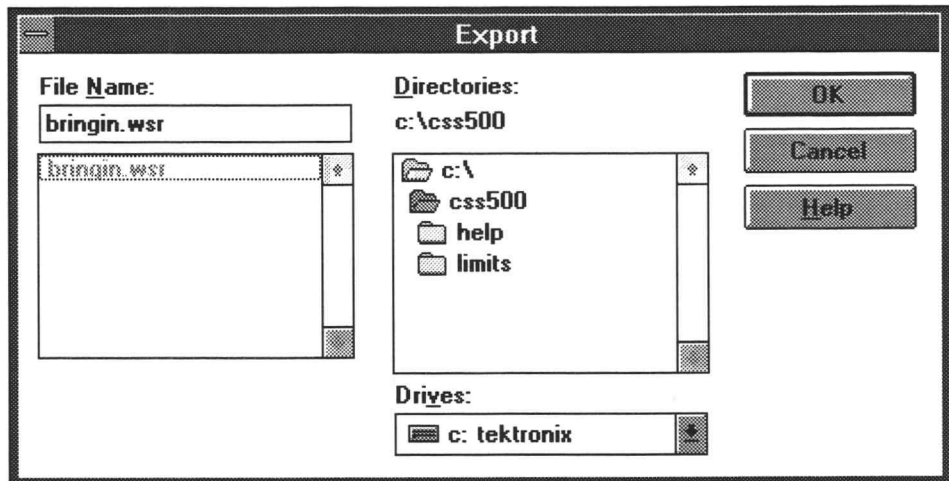

Figure 2-78: The Export dialog box

6. Enter a name for the destination file in the File Name combo box. The example uses the name “bringin.wsr”.
7. Select the OK command button. You are returned to the Get Stored Results dialog box as shown in Figure 2-79. Notice that the Site 888 now has the bringin.wsr results file associated with it and the Export button is disabled.

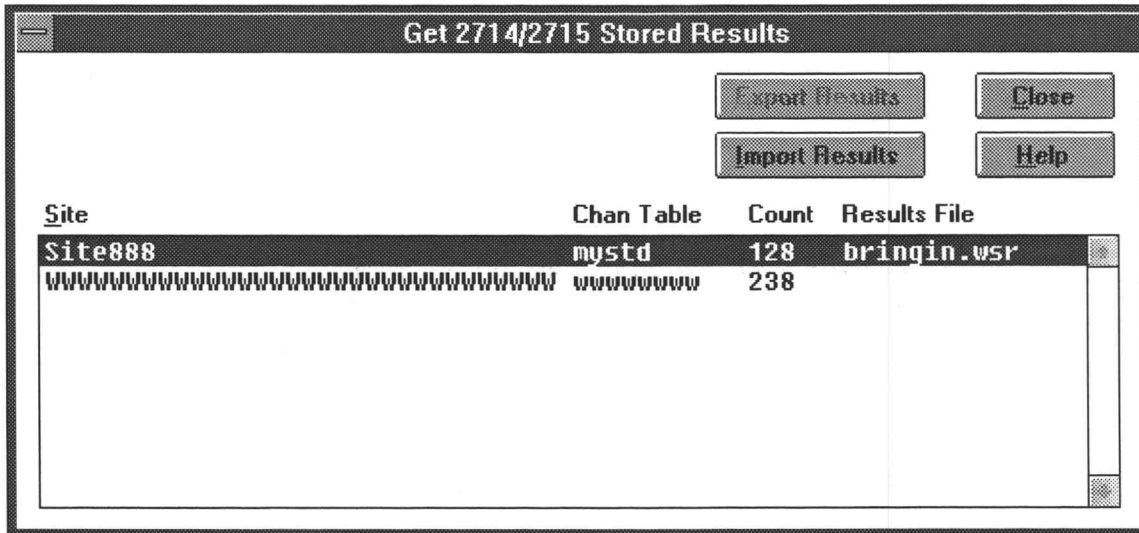

Figure 2-79: The Get Stored Results dialog box after the selected site results have been exported to a results file

8. Choose the Import Results command button to load the information into the current worksheet. Because no Site name is defined for this worksheet, the Site name in the exported file does not match and a message box like the one shown in Figure 2-80 appears.

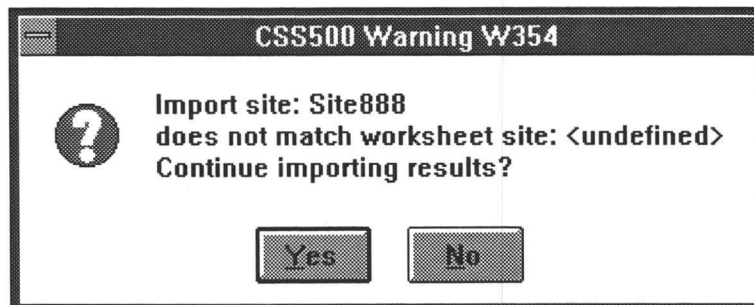
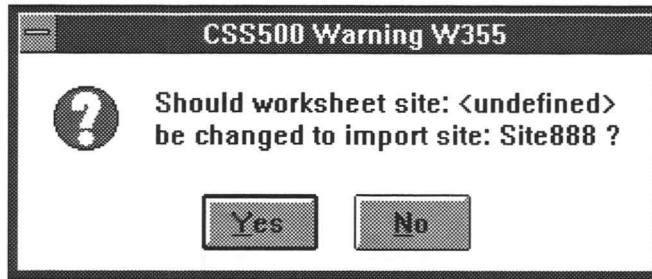

Figure 2-80: A warning that the site name does not match the current site name in the worksheet

9. Choose the Yes command button to continue importing the results. The Warning shown in Figure 2-81 then appears.



**Figure 2-81: Warning that the current site name does not match the imported site name**

10. Choose the Yes command button to change the worksheet site name to the site from the 2714/2715. Choosing No will attribute the imported measurement results to the Site name currently in the worksheet even if it is undefined. If the Channel Table in the worksheet does not match the one from the 2714/2715, the warning shown in Figure 2-82 appears.

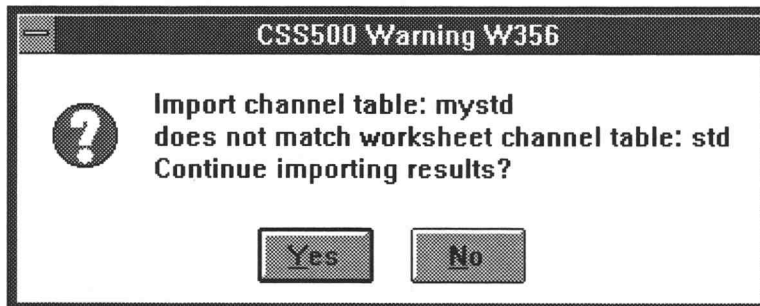

**Figure 2-82: Warning that the 271X and worksheet Channel Tables do not match**

11. Choose the Yes command button. The dialog box shown in Figure 2-83 appears. This dialog box is the result of a mismatch in the Channel Table. There will always be mismatches in the Channel Table because the 2714 (or 2715) stores only the channel number as the channel ID, while CSS500 stores channel number, tag, program name, and nominal visual carrier.



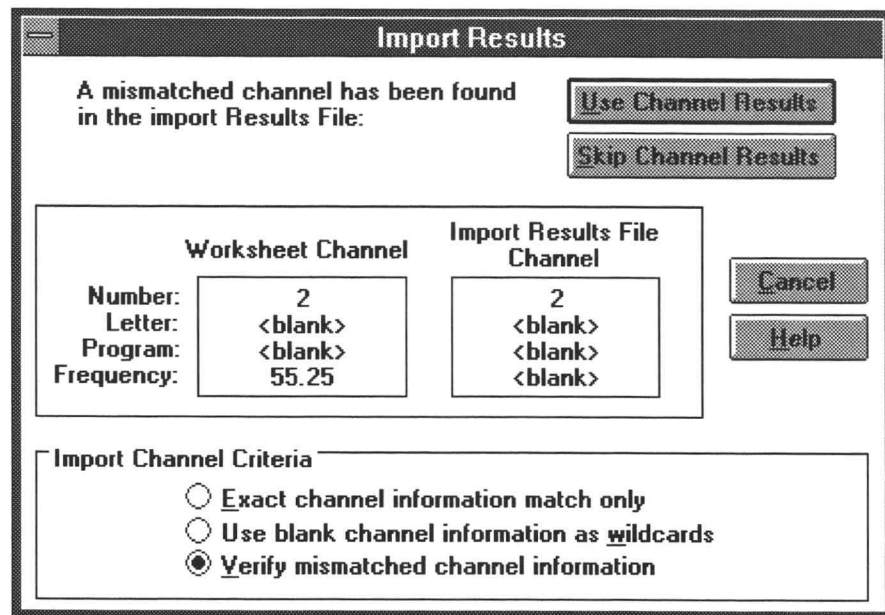

Figure 2–83: The Import Results dialog box

12. Select “Use blank channel information as wildcards” in the Import Channel Criteria sub-group.

Note that there are three Import Channel Criteria option buttons:

- Exact channel information match only
- Use blank channel information as wildcards
- Verify mismatched channel information

Generally, when using Import to get results from a 2714 (or 2715) into a worksheet, “Use blank channel information as wildcards” is the most efficient option, since there will never be an exact match. Although you could go through and verify each channel to make sure that the channel numbers match, using the “Use blank channel information as wildcards” selection is the most efficient way to load the data, because it reduces further prompts.

**NOTE.** Results for Channel Numbers not in the Worksheet's Channel Table are always ignored. You are notified that they were not loaded at the end of the import process. Any cell without results data or in error condition will not be imported. Cells that have more than one measurement will have all valid data imported and the Error data results left blank. Results from a channel table that his mismatches in the channel header, no destination channel, an inactive destination cell, or a user requested skip will not be imported.

Keep in mind that the destination channel must also be of the same type (analog or digital) as that of the imported data. For example, suppose the imported data has an Average Power result on channel 63; this means that channel 63 is a digital channel. If channel 63 in the worksheet is an analog channel, the Average Power destination cell is inactive; thus, the channel 63 Average Power result will not be imported.

13. Choose the Use Channel Results option button to load that channel's results and continue the import process. If there are no more mismatches, the import process is completed when a message box similar to Figure 2-84 appears. Make sure that the number of results transferred is similar to that listed in the Count column of the Get 2714/2715 Stored Results dialog box shown in Figure 2-79 (this is a cross check).

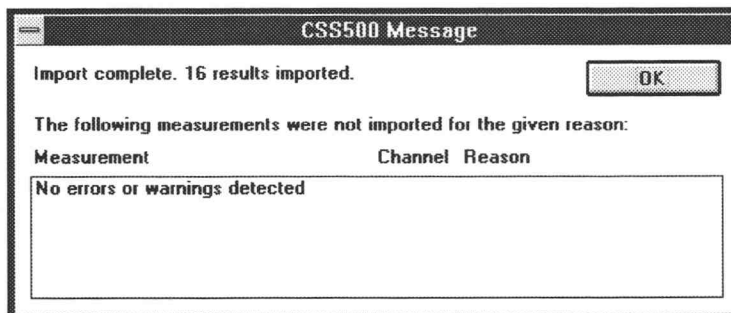

**Figure 2-84:** Message box that tells you that the import procedure is finished



# Reference

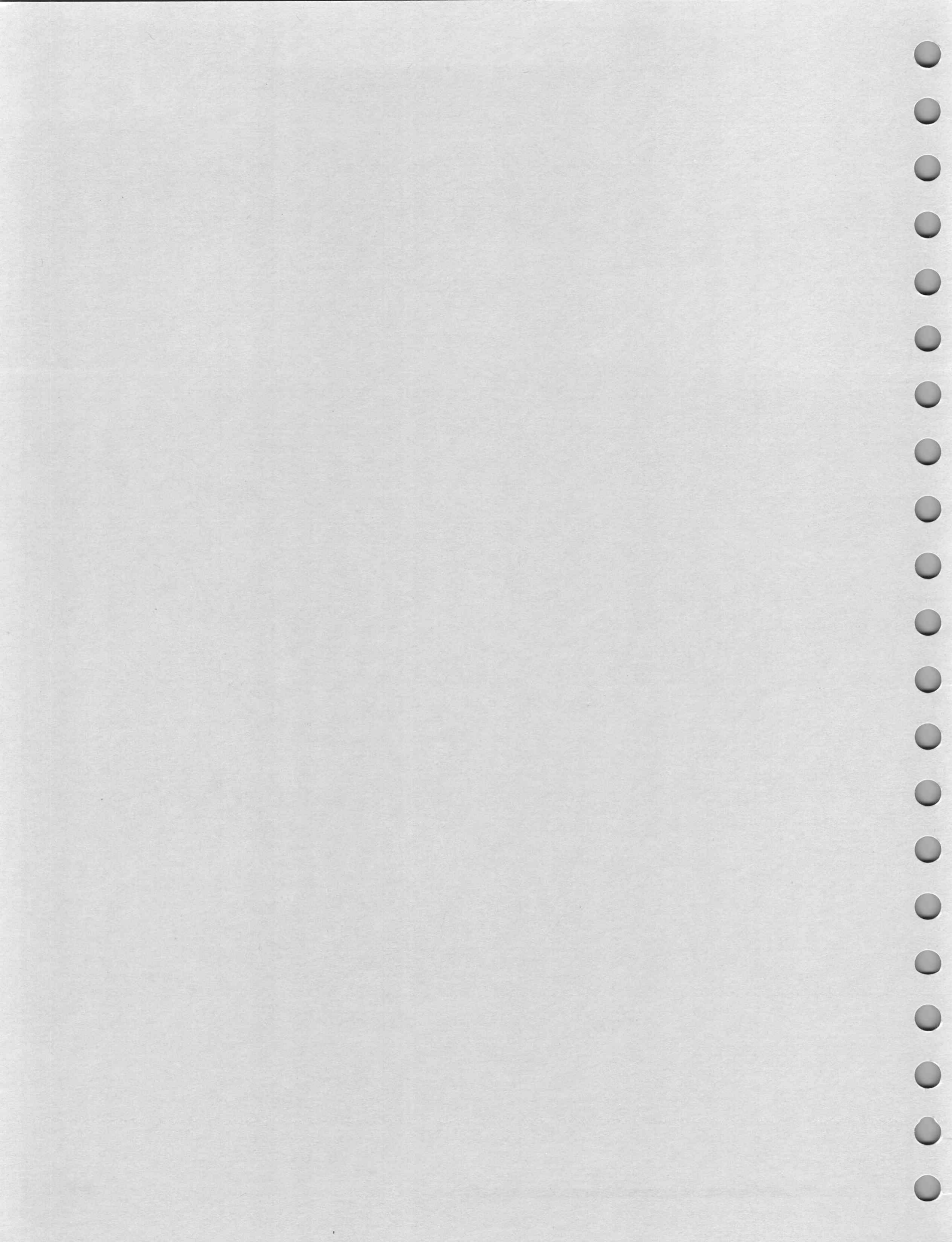

---

## Overview

This section contains several chapters that describe the CSS500 software in detail. Three chapters (*Parts of the Worksheet*, *Control Menu Box*, and *Menu Bar*) provide in-depth descriptions of all the menu commands available in the CSS500 software.



# Parts of the Worksheet

This chapter describes the various parts of the CSS500 worksheet. Each of the parts of the worksheet are identified in Figure 3-1.

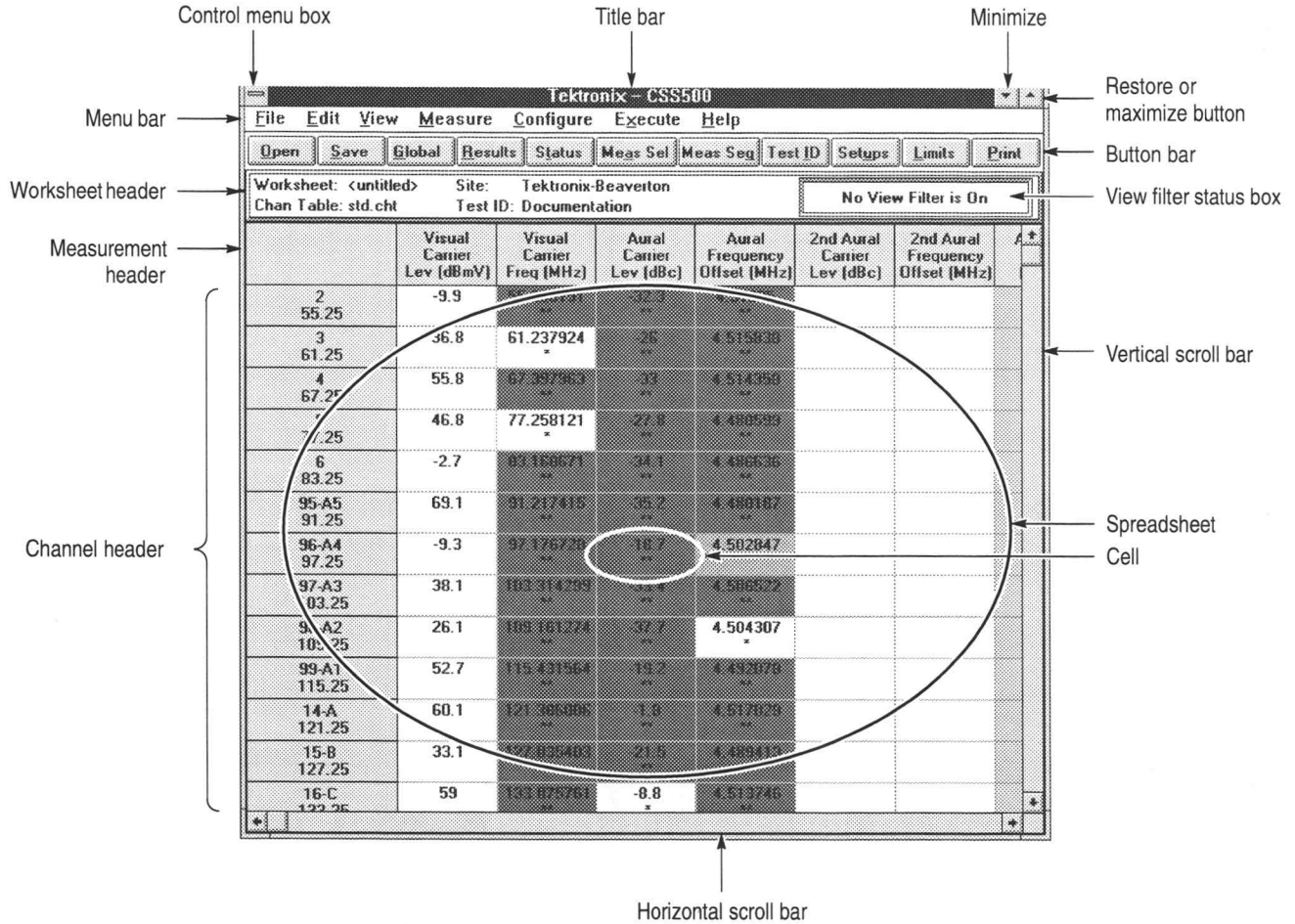

Figure 3-1: Parts of the CSS500 worksheet

## Title Bar

The Title Bar displays the name of the application that created the window. The active application's Title Bar is highlighted. The Title Bar is also a handle for moving the window. (Click on the Title Bar then hold down the left mouse button to move the window to the desired position.)

## Minimize Button



The Minimize button quickly shrinks the application to an icon, same as the Menu Control Box command, Minimize. (See page 3–10.)

## Maximize Button



The Maximize command makes the application window fill the entire display. (The Restore button replaces it when the window is at its maximum size.) This is the same as the Maximize command from the Menu Control Box. (See page 3–10.)

## Restore Button



The Restore button quickly returns the application window to its previous size. This is the same as the Menu Control Box command Restore. (The Maximize button replaces it whenever the window is not at its maximum size.) (See page 3–9.)

## Worksheet Header

The worksheet name, Channel Table, Site, Test Id and View Filter status are all listed in the Worksheet Header (see Figure 3–2).

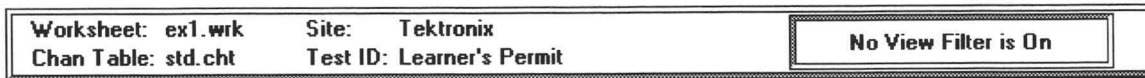

Figure 3–2: The worksheet header

- Worksheet** The worksheet name generally ends in “.wrk”. (It is good practice to make sure that it ends in .wrk for file organization.) Change using the Save As command (in the File menu; refer to page 3–13). This stays with the worksheet whenever it is saved.
- Chan Table** The Channel Table determines what channels are available. Edit using the Create/Edit Channel Table command button in Worksheet Info, from the Configure menu (see page 3–49) or Channel Table Editor from the Execute menu (see page 3–84). If you change the Channel Table name, CSS500 asks if you



want to save the worksheet as a new one because only one Channel Table is allowed for each worksheet. The Channel Table file should end in “.cht”.

---

**NOTE.** Use care when editing the Channel Table. See the warnings and explanations in Appendix C: Channel Table Editor for more information.

---

**Site** Site specifies the location where the measurements take place, but there are no defined values that this space must have. Change using the Configure menu, Worksheet Info (see page 3–49). If you change the Site, you are asked if you want to create a new worksheet because only one Site name can be associated with any worksheet. If you choose not to create a new worksheet, all of the measurement results are then associated with the new Site name.

**Test ID** This could be a person’s name, operator number, test session identification, or whatever is the most appropriate for your particular application. CSS500 allows multiple Test IDs for each worksheet. An example of why multiple Test IDs would be appropriate for one worksheet is to separate the Pre-converter, Post-converter, and 24 Hour results from the same Site.

**View Filter Status Box** This box tells if a View Filter is on. The choices are: No View Filter is On, View Selected Filter is On, View Sequence Filter is On, and View Test ID Filter is On. Enable the View Filters through the View menu, see page 3–26.

## Channel Header

This is the list of channels defined by the Channel Table. Change using the Create/Edit Channel Table command button (from the Configure menu, Worksheet Info, see page 3–49). There are up to four fields in each Channel cell. They are: Number, Tag, Visual Frequency, and Program.

- Number. The number by which this channel is commonly known.
- Tag. A 3-character designation for the channel, such as “AAA” or “2-B”.
- Program. A 6-character identifier for the channel, usually used for the channel’s call letters or abbreviated name.
- Visual Frequency. The frequency of the visual carrier.

You can edit which fields are displayed using the Row Header Fields from the View menu (see page 3–44).

The Channel Table Editor defines these fields; see Appendix C.

## Measurement Header

The Measurement Header is the measurement list. The measurement list includes (additional measurements made under this Header are in parentheses):

- Visual Carrier Level
- Visual Carrier Frequency
- Aural Carrier Level
- Aural Frequency Offset
- Second Aural Carrier Level
- Second Aural Offset Frequency
- Average Power
- Carrier to Noise
- Desired to Undesired
- CSO
- CTB
- Cross Modulation
- Adjacent Channel Leakage
- In-Channel Response
- HUM/LFD
- FCC Baseband or Primary Baseband (if non-US)  
(Chrominance/Luminance Delay, Chrominance/Luminance Gain, Differential Gain, and Differential Phase)
- Modulation Depth
- Aural Deviation
- Signal to Noise  
(if NTSC: S/N NTC-7 Unweighted and S/N NTC-7 Lum Weighted  
if PAL: S/N 567 Unweighted and S/N 567 Lum Weighted)
- Waveform Distortion  
(for NTSC: Line Time Distortion, Pulse-to-Bar Ratio, Short Time Distortion,  
2T K-Factor, Luminance Nonlinear Distortion, Chrominance to Luminance  
Intermodulation (IRE), Chrominance Phase (Deg), Chrominance Gain  
20 IRE, Chrominance Gain 80 IRE.  
For PAL: Line Time Distortion, Pulse to Bar Ratio, 2T K-Factor, Luminance

Non-Linear Distortion, Chrominance Amplitude Maximum, Chrominance Amplitude Minimum, Chrominance Gain Maximum, Chrominance Gain Minimum, Chrominance Intermodulation Packets #1 – #3.)

- **Multiburst**  
(If NTSC: Multiburst ICR, Multiburst Flag (% Carr), Multiburst Flag (%Bar/IRE), Multiburst Packet #1, Multiburst Packet #2, Multiburst Packet #3, Multiburst Packet #4, Multiburst Packet #5, and Multiburst Packet #6  
If PAL: Multiburst ICR, Multiburst Flag (% Bar), Multiburst Flag (% mV), Multiburst Packet #1, Multiburst Packet #2, Multiburst Packet #3, Multiburst Packet #4, Multiburst Packet #5, and Multiburst Packet #6)
- **ICPM**
- **Audio**  
(Left and Right Insertion Gain Error, Left and Right Sweep Maximum Gain, Left and Right Sweep Minimum Gain, Left and Right Polarity, Left and Right Stereo Channel Assignment, Left and Right SNR weighted, Left and Right Maximum THD+N, Left and Right Maximum THD+N 10dB, Left and Right Maximum THD+N 15dB, Left and Right Maximum Crosstalk, Gain Difference, and Phase Difference.)

---

**NOTE.** *The Short Time Distortion measurement, under Waveform Distortion Measurement Header, requires a 1T pulse not normally found in the Composite VITS signal. (It is available in the NTC-7 VITS signal.)*

*When it is available, note that the 1T pulse distorts after a very short cable run. Use this measurement primarily for in-house measurements.*

---

## Vertical Scroll Bar

The Vertical Scroll Bar moves the spreadsheet up and down, allowing access to all channels. You can either click on the up or down arrow boxes to move one step at a time, or click and hold the box, dragging it to the desired position.

## Horizontal Scroll Bar

The Horizontal Scroll Bar moves the spreadsheet right and left, allowing access to all measurements. To use the Horizontal Scroll Bar, either click on the right or left arrows to move one step at a time, or click and hold the box, dragging it to the desired position.

## Cursor

The cursor can take on one of several shapes depending upon the functions available to it.

It is a cross when it is in the spreadsheet. From there it can select cells, request a measurement on a selected cell, or go to the Results Detail display.

It is an arrow if it is in the menu portion of the display. From there it moves through the menu.

It can also be an hourglass. If the cursor is an hourglass, CSS500 is busy processing a command. You cannot request any more actions until it turns back into either an arrow or a cross.

It can be a two-or four-headed arrow for sizing the application window.

If no mouse is available, the cursor is either a box around a cell or command button, reversed text on the command line, reversed cells in the spreadsheet, or a two-or four-headed arrow for sizing the window.

# Control Menu Box



The Control menu box contains standard Windows commands used to manipulate the application window and change to other applications (see Figure 3-3).

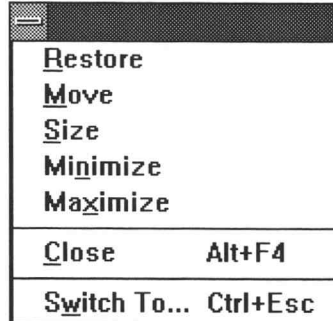

Figure 3-3: The Control menu box

## Restore

The Restore command returns the CSS500 application window to its previous size and position. It is often used to change an icon back into a window. It will also toggle the window between two different sizes and positions. It performs the same functions as the Restore command button (small box with both up and down arrows) on the upper right hand corner of the worksheet. (See page 3-4.)

## Move

Move allows different placements of the CSS500 window. This is equivalent to clicking on the Title Bar and holding down the left mouse button to reposition the display. The Move command is only available if the application window is not at its maximum size (when the Maximize button, in the upper right corner, is available).

To use Move with the keyboard:

1. Choose Move. (Press ALT+spacebar, then type m.)
2. Press the arrow keys until the window is in the desired position.
3. Press Enter to place the window in the new position or press ESC to stop moving the window.

## Size

Size allows you to change the size of the application window. Size is not available when the application window is maximized. (See the Windows manual.)

To change the size of the window using the keyboard:

1. Press ALT+spacebar to enter the Control menu box.
2. Press s to choose Size. The cursor changes to a 4-headed arrow.
3. Press the arrow keys to change the size of the window. The cursor changes to a 2-headed arrow.
4. Press Enter to accept the new size or press ESC to cancel changing the size of the window.

## Minimize

The Minimize command changes the application to an icon. The application is still running but it is no longer the active window. CSS500 stays in the same operating state as when it was converted to an icon. This performs the same function as the Minimize button (small box with the down arrow) on the upper right corner of the worksheet. (See page 3-4.)

## Maximize

The Maximize command changes an icon to an active window. This also changes a sized window into one that fills the entire display. Maximize performs the same function as the Maximize command button (small box with an up arrow) on the upper right corner of the worksheet. (See page 3-4.)

## Close

Close halts any Measurement Sequence in progress, closes the CSS500 application window and exits the application.

## Switch To

The Switch To command changes from one running application to another. This enables you to change from CSS500 to Excel (to process the data) and then back to CSS500 (to get more data) without closing the CSS500 application.

## Menu Bar

The Menu Bar lists the available menus. There are seven menus: File, Edit, View, Measure, Configure, Execute, and Help. If you are using a mouse, click on the word with the left mouse button to open the drop down menu associated with each. If a mouse is not available, then press ALT+the underlined letter of the selected menu item to make the drop-down menu available. For example: to get the File menu, press ALT+f. The following sections describe each menu item.

### File

The File menu is used to open, save, import, export and print files (see Figure 3-4).

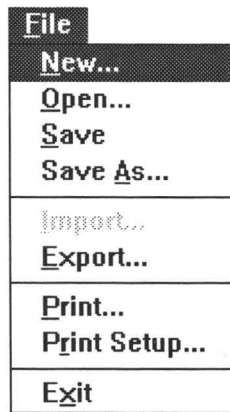

**Figure 3-4: The File menu**

**New** New creates a new worksheet. New automatically sets all Measurement Setups and Limits files to defaults, not what is in the current worksheet. All results in the current worksheet are either saved to that worksheet or deleted. New also erases any Measurement Sequences that may have been defined.

There are three fields in the New dialog box; see Figure 3-5. The fields are: Site, Description, and Channel Table.

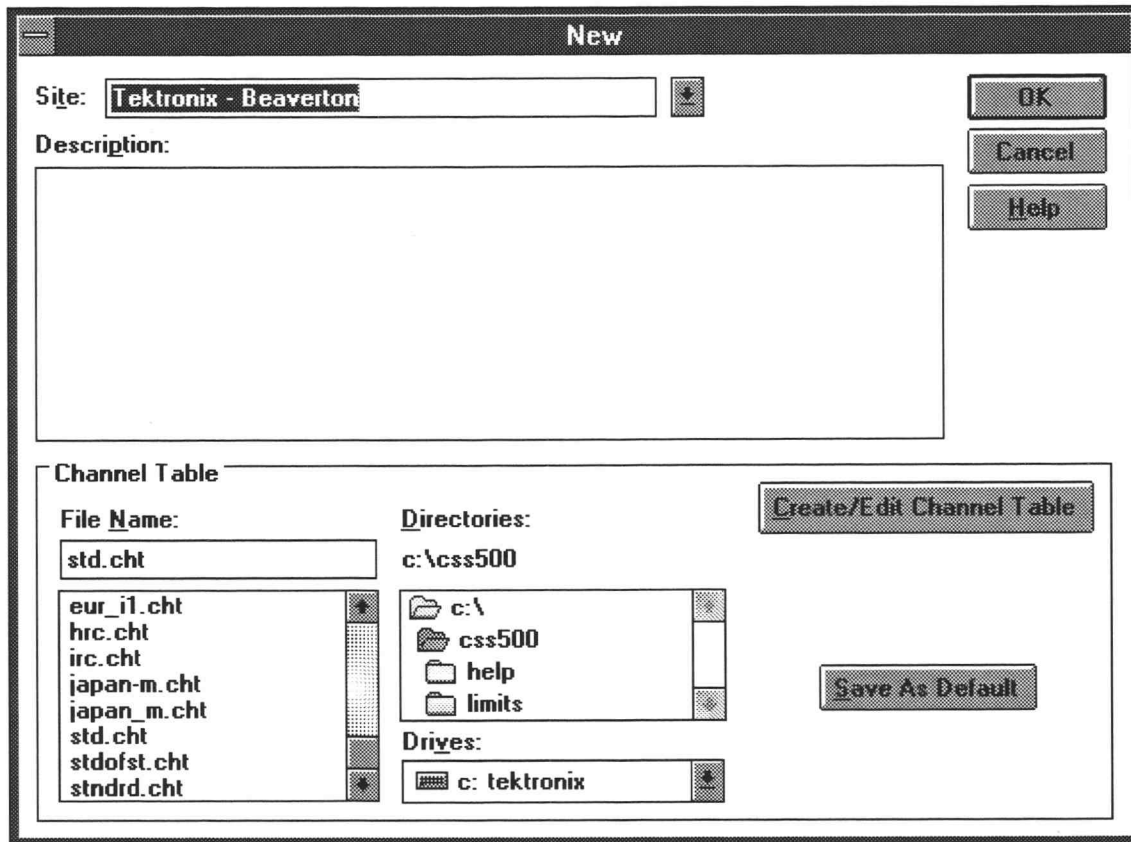

Figure 3-5: The New dialog box

- Site. Site specifies the location where the measurements take place. The Site field has a default value of undefined; the Site field can remain undefined.
- Description. Fill this field with anything that may be relevant to this worksheet. For example, how certain measurements are made and the serial numbers of the test equipment. You can copy this information to the Windows' Clipboard and then attach it to an Excel spreadsheet. Carriage returns are allowed in this field.
- Channel Table. This field specifies the Channel Table for the worksheet. The Channel Table defines the channels available, their frequencies, and other important information. You can change or edit the current Channel Table by using the Create/Edit Channel Table command button. Editing the Channel Table without changing the name is not recommended. Please see Appendix C for more information about editing a Channel Table.



There are two command buttons in the Channel Table field; the command buttons are Create/Edit Channel Table and Save As Default.

- **Create/Edit Channel Table.** This command button launches the Channel Table Editor. Use the Channel Table Editor to add, delete, or change information in a Channel Table. See Appendix C for more information on the Channel Table Editor.
- **Save As Default.** This command button allows you to save the current Channel Table as the default. This will cause the selected Channel Table to automatically load every time the CSS500 software starts.

**Open** Opens an existing worksheet. (See Figure 3–6.)

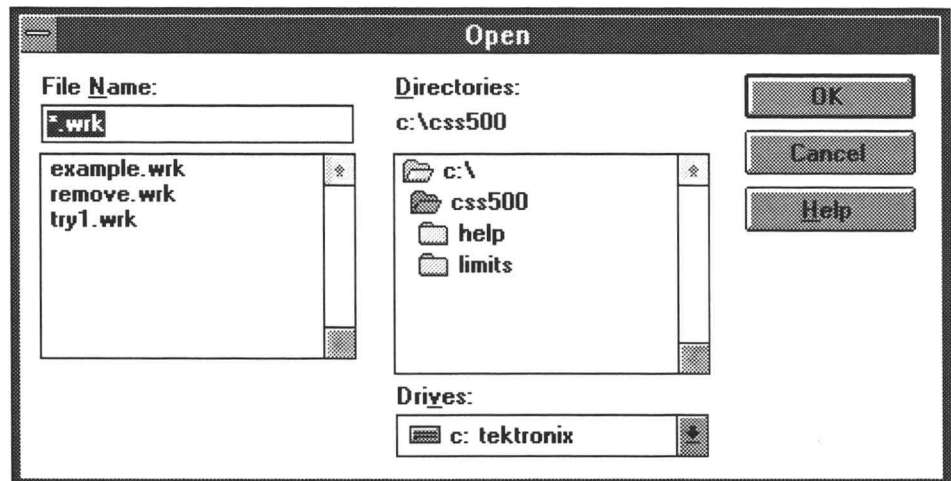

Figure 3–6: The Open dialog box

**Save** The Save command saves the changes made to the present worksheet.

**Save As** The Save As command saves the present worksheet under a new name. The worksheet name has the same naming restrictions as any other MS-DOS file (no more than 8 characters; some names such as LPT1 and GPIB1 are not allowed; etc.) See Figure 3–7 for an example of the dialog box. Notice that existing worksheet names appear in gray.

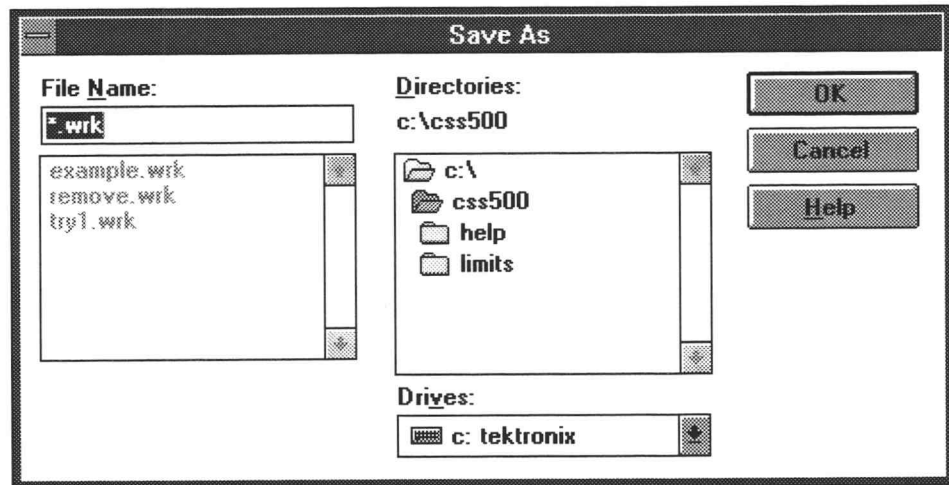

Figure 3-7: The Save As dialog box



**CAUTION.** *There are restrictions on the acceptable worksheet names. You cannot use any name that is also used by IBCONF. (IBCONF is the configuration program used by the GPIB card.) For example, if you have a GPIB device named “2715,” you cannot have a worksheet called “2715.wrk”. This will cause an error.*

## Import

The Import command brings in data from another source (see Figure 3-8). An acceptable source is results data previously exported from CSS500. Import can be used to load data collected at remote locations such as the 271X’s UDPs (User Defined Program). If the Channel Table or Site does not match the present worksheet, you are asked if you want to continue importing the results. If the Channel Table does not match and you continue to import, the results will map to the Channel Number, skipping any channel not in the worksheet’s Channel Table. If the Site does not match, you have the option to choose if you want to use the worksheet Site or the imported data’s Site.

It is good practice to import into a blank worksheet to minimize the possibility of conflicts and unexpected data placement. If you don’t write to a blank worksheet, Import will not overwrite your work. History is automatically turned on before an Import takes place, and turned off again when Import is complete. For example, you have data in one cell. Import data into that cell (with Keep only Last Result set in the Preferences menu). Your data is still there and the imported data falls into its place in the history stack (either before or after the current results).

The data is stored in the worksheet according to Date/Time. If the data that you are importing is older than the current data in the worksheet, then the imported

data is not visible in the worksheet. It is available in Results Detail with View History turned on.

Any cell that has no results data or is in Error condition does not get imported. Cells that have more than one measurement will have all valid data imported and the Error data results left blank. Also, results from channels that are not in the worksheet's Channel Table are ignored.

The destination channel must also be of the same type (analog or digital) as that of the imported data. For example, suppose the imported data has an Average Power result on channel 63; this means that channel 63 is a digital channel. If channel 63 in the worksheet is an analog channel, the Average Power destination cell is inactive; thus, the channel 63 Average Power result will not be imported.

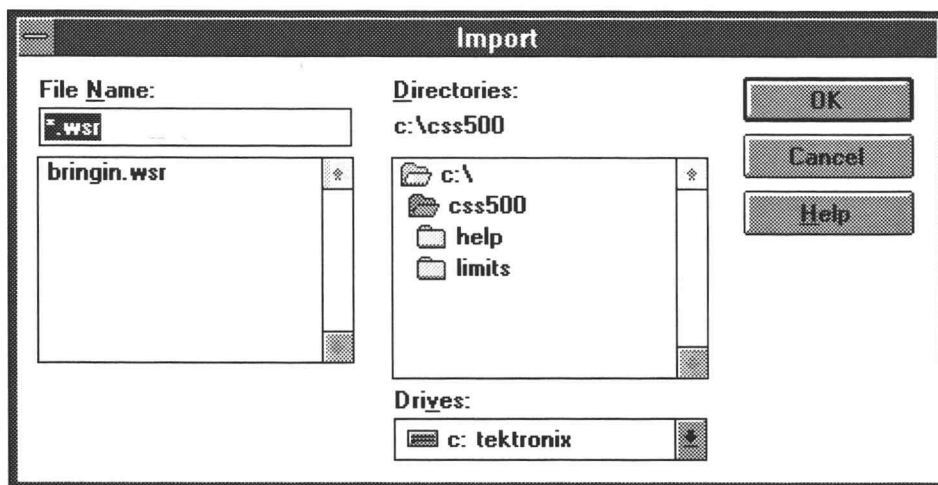
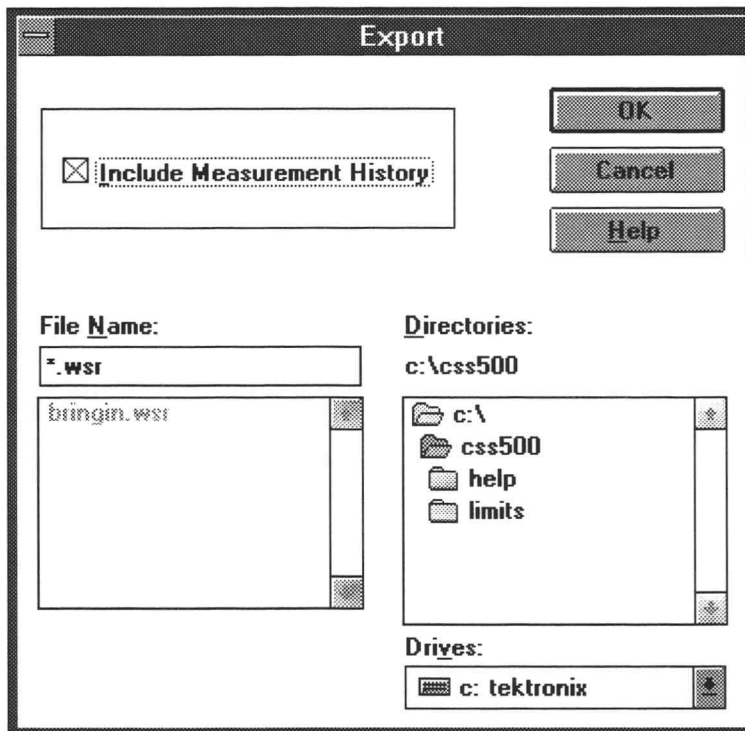

Figure 3-8: The Import dialog box

**Export** The Export command (see Figure 3–9) sends the results worksheet data out to a “.wsr” file, so that other applications, such as Excel, can process the data.



**Figure 3–9: The Export dialog box**

The export file includes all Worksheet Header information.

If only certain cells need to be exported, use Copy (under Edit; see page 3–23) and copy the data to the clipboard.

The main difference between using Copy from the Edit menu (Export Format option) and using Export is that Export sends data to a named file while Copy copies the data to the clipboard.

**Print** The Print command sends the spreadsheet to the printer. (See Figure 3–10.) Within the Print dialog box, the Setup command button is identical to choosing Print Setup from the File menu.

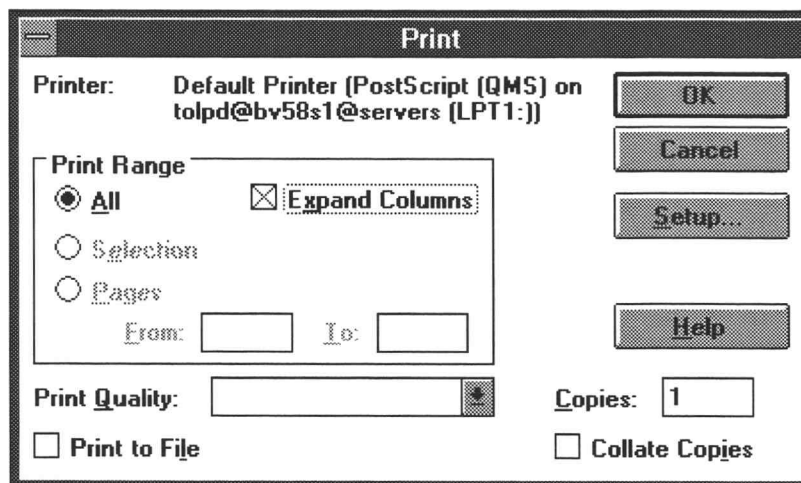

**Figure 3–10: The Print dialog box**

The Print dialog box allows you to choose if you are going to print out the worksheet as it appears in the display or with certain columns expanded to display additional information.

If you do not use the Expand Columns option, CSS500 prints out the measurement results cells just as they are shown in the worksheet. The main concern with using this method is that some cells will only display PASS, CAUTION, or ALARM. You may need more information.

Printing using Expand Columns fills in all cells with detailed measurements that would otherwise print only pass/fail. The columns that expand are: FCC Baseband, Signal to Noise, Waveform Distortion, Multiburst, and Audio. A concern with using this format is that it produces long reports. (See Table 3–1.) What is printed from each cell in the expanded mode is all of the results that you would normally find in the Results Detail display. For example, the single Audio column in the display format grows to 22 columns when it is printed out with expanded columns. Since printing using Expand Columns creates such a long printout, you should use the Measurements and Channels View Filter from the View menu to limit the measurements printed in each worksheet. For example, to print out all of the information from a worksheet in a more useful format, you might print one expanded worksheet of the RF measurements, one for the Baseband measurements, and one for the Audio.

---

**NOTE.** To print some reports (ones with many columns), you may want to change from portrait to landscape orientation. Use the Print Setup command to make the required changes.

---

You can save paper if you only print out measurements and channels that have results associated with them. Use the View Used command button from Measurements and Channels dialog box in the View menu. (See page 3–40 for more details.)

**Table 3–1: The measurements under each measurement header**

Measurement header	Measurements under the measurement header
Visual Carrier Lev (dBmV)	Visual Carrier Level (dBmV)
Visual Carrier Freq (MHz)	Visual Carrier Frequency (MHz)
Aural Carrier Lev (dBc)	Aural Carrier Level (dBc)
Aural Frequency Offset, (MHz)	Aural Frequency Offset (MHz)
2nd Aural Carrier Lev (dBc)	2nd Aural Carrier Level (dBc)
2nd Aural Frequency Offset (MHz)	2nd Aural Frequency Offset (MHz)
Average Power (dBmV)	Average Power (dBmV)
Carrier to Noise (dB)	Carrier to Noise (dB)
Desired to Undesired	Desired to Undesired (dB)
CSO	CSO Loc 1 (dBc) CSO Offset 1 (MHz) CSO Loc 2 (dBc) CSO Offset 2 (MHz) CSO Loc 3 (dBc) CSO Offset 3 (MHz) CSO Loc 4 (dBc) CSO Offset 4 (MHz) CSO Loc 5 (dBc) CSO Offset 5 (MHz)

**Table 3–1: The measurements under each measurement header (Cont.)**

<b>Measurement header</b>	<b>Measurements under the measurement header</b>
CTB	CTB Loc 1 (dBc) CTB Offset 1 (MHz) CTB Loc 2 (dBc) CTB Offset 2 (MHz) CTB Loc 3 (dBc) CTB Offset 3 (MHz) CTB Loc 4 (dBc) CTB Offset 4 (MHz) CTB Loc 5 (dBc) CTB Offset 5 (MHz)
Cross Modulation	Cross Modulation (dBc)
Adjacent Channel Lkg. (dBc)	Adjacent Channel Leakage (dBc)
In-Channel Response	In-Channel Response (dB)
HUM/LFD	Hum/LFD (%) Hum/LFD Fundamental (%) Hum/LFD Second Harmonic (%)
FCC Baseband (NTSC only)	Chroma-Luma Delay (ns) Chroma-Luma Gain (%) Differential Gain (%) Differential Phase (Deg)
Primary Baseband (PAL)	Chroma-Luma Delay (ns) Chroma-Luma Gain (%) Differential Gain (%) Differential Phase (Deg)
Modulation Depth (%)	Modulation Depth (%)
Aural Deviation (kHz)	Aural Deviation (kHz)
Signal to Noise (NTSC)	S/N NTC7 Unweighted (dB) S/N NTC7 Weighted (dB)
Signal to Noise (PAL)	S/N 567 Unweighted (dB) S/N 567 Lum Weighted (dB)

**Table 3–1: The measurements under each measurement header (Cont.)**

<b>Measurement header</b>	<b>Measurements under the measurement header</b>
Waveform Distortion (NTSC)	Line Time Distortion (%) Pulse to Bar Ratio (%) Short Time Distortion (%SD) 2T K-Factor (%Kf) Lum Non-linear Distort (%) Chrom. to Lum. Intermod (IRE) Chrominance Phase (Deg) Chrominance Gain (20 IRE) Chrominance Gain (80 IRE)
Waveform Distortion (PAL)	Line Time Distortion (%) Pulse to Bar Ratio (%) 2T K-Factor (%Kf) Lum Non-linear Distort (%) Chroma Amp Max (%) Chroma Amp Min (%) Chroma Gain Max (Deg) Chroma Gain Min (Deg) Chroma Intermod Pkt #1 (%) Chroma Intermod Pkt #2 (%) Chroma Intermod Pkt #3 (%)
Multiburst	Multiburst ICR (dB) Multiburst Flag (% Carr) Multiburst Flag (%Bar/IRE) Multiburst Packet #1 (%Flag) Multiburst Packet #2 (%Flag) Multiburst Packet #3 (%Flag) Multiburst Packet #4 (%Flag) Multiburst Packet #5 (%Flag) Multiburst Packet #6 (%Flag)



**Table 3–1: The measurements under each measurement header (Cont.)**

<b>Measurement header</b>	<b>Measurements under the measurement header</b>
ICPM	ICPM (Deg)
Audio	Left Insertion Gain Error (dB) Right Insertion Gain Error (dB) Left Sweep Max Gain (dB) Right Sweep Max Gain (dB) Left Sweep Min Gain (dB) Right Sweep Min Gain (dB) Left Polarity Right Polarity Left Stereo Channel Assignment Right Stereo Channel Assignment Left SNR weighted (dB) Right SNR weighted (dB) Left Max THD+N (%) Right Max THD+N (%) Left Max THD+N 10dB (%) Right Max THD+N 10dB (%) Left Max THD+N 15dB (%) Right Max THD+N 15dB (%) Left Max Crosstalk (dB) Right Max Crosstalk (dB) Gain Difference (dB) Phase Difference (dB)

**Print Setup** Sets up the printer so that it can properly print worksheets and reports. (See Figure 3–11.) This is identical to the standard Windows’ printer setup. Please see the *Windows User’s Guide* or on-line Help for more information.

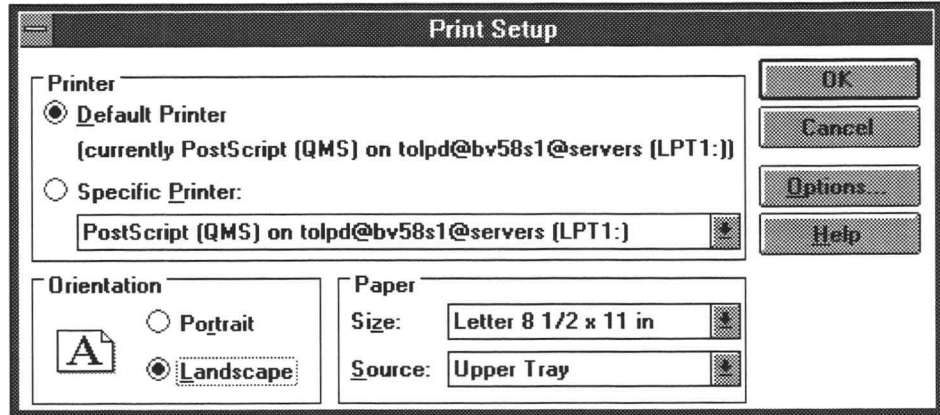

**Figure 3–11: The Print Setup dialog box**

---

**NOTE.** Most worksheets and reports are more readable if printed using Landscape orientation.

---

**Exit** Exit closes the CSS500 application.

## Edit

The Edit menu is used to manipulate the contents of selected cells (see Figure 3-12).

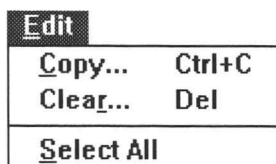

Figure 3-12: The Edit menu

**Copy** The Copy command (see Figure 3-13) copies the contents of the selected cells to the Windows Clipboard. CSS500 asks if you want the cells in Export format or As Displayed. If you select Export format, you also have a choice of whether to include the measurement history. In Export format, not only is the displayed cell data copied to the clipboard, but also the Results Detail information. If you chose the As Displayed format, only the data in the selected cells along with the Measurement and Channels Headers are copied to the clipboard. The result of copying one cell with history (using export format) into Word for Windows is given in Table 3-2.

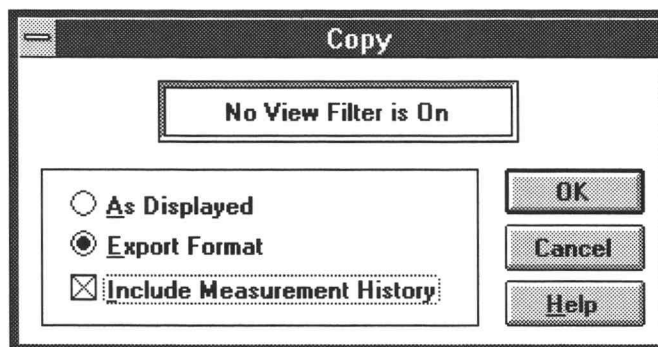

Figure 3-13: The Copy dialog box

**Table 3–2: The results of copying one cell with history into Word for Windows**

Worksheet File	Site												
	Tektronix Beaverton												
Channel Table	Video Standard	Aural Offset											
2715.cht	NTSC	.5											
Channel	Freq	Program	S/N Unweighted (dB)	Viol	LL	UL	S/N Weighted (dB)	Viol	LL	UL	Notes	Date/Time	Test ID
2	.25		.1	**			.8	**				6/7/1995 13:44:35	Training Wheels
2	.25		.7				.2					6/7/1995 13:44:22	Training Wheels
2	.25		.7				.3					6/7/1995 13:44:18	Training Wheels
2	.25		.4				.7					6/7/1995 13:42:53	Training Wheels

Below is a description of how Table 3–2 was created:

1. Select one cell from the worksheet.
2. Choose copy from the Edit menu.
3. Select Export format and include measurement history.
4. Choose OK.
5. Open the desired Word for Windows document.
6. Place the cursor in the desired location in the Word document.
7. From the Edit menu, choose Paste. All the cell information is placed in the document.
8. Select all of the data that was just pasted into the document.
9. From the Table menu, choose Convert Text to Table.
10. Select “Tabs” as the column spacer.
11. Choose OK.
12. Adjust the column width as necessary.

---

**NOTE.** Both Word and Excel have a limited number of columns. Word's limit is 31 columns. Excel's limit is 256 columns. Each cell will produce a large number of columns; see the example in Table 3–2 above. Take this into consideration when copying data into these applications.

---

The As Displayed format only copies the displayed cell contents and Channel and Measurement Headers associated with the selected cells to the clipboard. The results of copying one cell using the As Displayed format are shown in Table 3–3.

**Table 3–3: The results of copying one cell using the As Displayed format**

	Carrier to Noise (dB)
2 55.25	41**

**Clear** The Clear command (see Figure 3–14) deletes the current value and/or all history for the selected cells. There is always a warning to verify that you really want to delete the contents of the cells. Select CANCEL if you do not want results deleted.

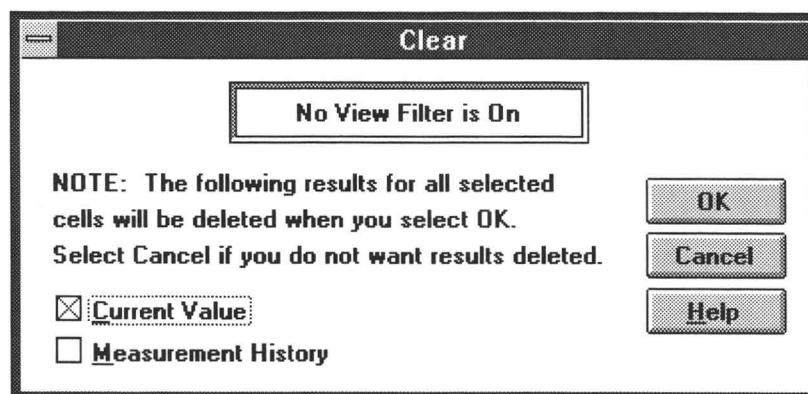

**Figure 3–14: The Clear dialog box**

**Select All** The Select All command selects all of the cells in the spreadsheet. If you are using a mouse, you can obtain the same results by clicking the left mouse button on the upper left corner of the spreadsheet.

## View

The View menu (see Figure 3–15) allows you to see the spreadsheet data presented in several different ways, such as filtered or consolidated into reports.

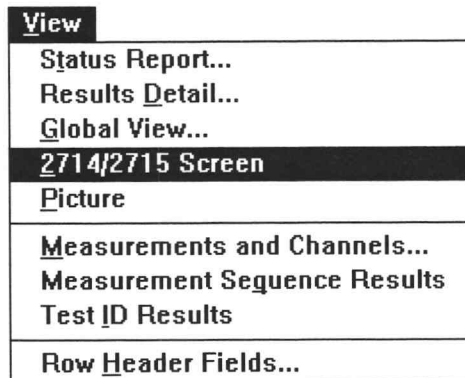

Figure 3–15: The View menu

### Status Report

Choosing Status Report from the View menu (see Figure 3–16) is the same as choosing the Status command button on the Button Bar (see page 3–86). A shortcut for getting to this display is to click the right mouse button on the upper left corner of the spreadsheet. Any of these methods displays the Status Report for the current worksheet.

Status Report							
Channel Table: std.cht Site: Tektronix-Beaverton No View Filter is On			View Results Detail		Close		
			View Violations		Help		
			<input type="checkbox"/> Include History		Print		
Measurement Summary							
Channel	Measurement	Type	Result	*	Violated Lower Limit	Violated Upper Limit	↑
6	Visual Carrier Level (dBmV)	Max	48				
4		Min	-7.8				
6, 4	Visual Carrier Level Diff. (dB)	Max-Min	55.8	**		10	
3, 4	Visual Carrier Level Adj. (dB)	Max	52.8	**		3	
3	Visual Carrier Frequency (MHz)	Max Dev	61.004256	**	61.225		
6	Aural Carrier Level (dBc)	Max	-12.2				
5		Min	-37.3	**	-17		
2	Aural Frequency Offset (MHz)	Max Dev	4.480599	**	4.495		
2	Carrier to Noise (dB)	Min	15.5	**	43		
2	CSO (dBc)	Max	20.7	**		-51	
2	CTB (dBc)	Max	-53.3	*		-54	
2	Cross Modulation (dBc)	Max	-72.9				
2	In-Channel Response (dB)	Max	0				
2	Hum/LFD (%)	Max	1				
2	Chroma-Lum Delay (nS)	Max	42.7				
2		Min	42.7				
2	Chroma-Lum Gain (%)	Max	100.4				
2		Min	100.4				

Figure 3-16: The Status Report

The Status Report lists the extremes for all of the measurement results. It is basically a summary of all Measurement Summaries (see page 3-36). Table 3-4 lists the measurement results given in the Status Report. If there are no results for a measurement, it is skipped in the Status Report. You can limit the channel and measurements in the Status Report by using the View Filters (see *Measurements and Channels* on page 3-40). Optionally, you can include the measurement History.

Table 3-4: The Measurement summaries in the status report

Measurement	Max	Min	Max-Min	Max Dev	Max Abs
Visual Carrier Level (dBmV or dBuV) <sup>1</sup>	x	x			
Visual Carrier Level Diff (dB) <sup>2</sup>			x		

<sup>1</sup> Absolute power level.

<sup>2</sup> Difference between the maximum and minimum values over all the channels measured.

**Table 3–4: The Measurement summaries in the status report (Cont.)**

Measurement	Max	Min	Max-Min	Max Dev	Max Abs
Variation (dB) <sup>3</sup>	x				
Visual Carrier Level Adj. (dB) <sup>4</sup>	x				
Visual Carrier Frequency (MHz) <sup>5</sup>				x	
Aural Carrier Level (dBc)	x	x			
Aural Frequency Offset (MHz) <sup>6</sup>				x	
2nd Aural Carrier Level (dBc)	x	x			
2nd Aural Frequency Offset (MHz)				x	
Average Power (dBmV or dBuV) <sup>1</sup>	x	x			
Carrier to Noise (dB)		x			
Desired to Undesired (dB)		x			
CSO (dBc)	x				
CTB (dBc)	x				
Cross Modulation (dBc)	x				
Adjacent Channel Leakage	x				
In-Channel Response (dB)	x				
Hum/LFD (%) <sup>7</sup>	x				
Chroma-Luma Delay (nS)	x	x			
Chroma-Luma Gain (%)	x	x			
Differential Gain (%)	x	x			
Differential Phase (Deg)	x	x			
Modulation Depth (%)	x	x			
Aural Deviation (kHz)	x	x			

- <sup>3</sup> If four or more Visual Carrier Levels measurements are being summarized for a single channel. Difference between the maximum and minimum values for the several measurements done over time on a given channel. (Variation appears only if Collect History is selected in the Preferences dialog box.)
- <sup>4</sup> Maximum difference between and two adjacent channels. See Summary Limits Group (page 2–84 ) to set these summary limits, a definition of Adjacent, and for types of channels to include.
- <sup>5</sup> Maximum deviation from nominal as defined in the Channel Table. The value shown is the measured frequency, the violated limits are shown as nominal + limit offset as defined in the Limits file. Variations always include both current and all previous data, whether history is selected or not.
- <sup>6</sup> Maximum deviation from nominal as defined in the Channel Table.
- <sup>7</sup> Total Hum.



Table 3–4: The Measurement summaries in the status report (Cont.)

Measurement	Max	Min	Max-Min	Max Dev	Max Abs
S/N NTC7 Unweighted (dB) <sup>8</sup>		x			
S/N NTC7 Weighted (dB) <sup>8</sup>		x			
S/N 567 Unweighted (dB) <sup>9</sup>		x			
S/N 567 Lum Weighted (dB) <sup>9</sup>		x			
Line Time Distortion (%)	x				
Pulse to Bar Ratio (%)	x	x			
Short Time Distortion (%SD) <sup>8, 10</sup>	x				
2T K-Factor (%Kf)	x				
Lum Non-linear Distortion (%)	x				
Chroma to Luma Intermod (IRE) <sup>8</sup>	x	x			
Chrominance Phase (Deg) <sup>8</sup>	x				
Chrominance Gain (20 IRE) <sup>8</sup>	x	x			
Chrominance Gain (80 IRE) <sup>8</sup>	x	x			
Multiburst ICR (dB)	x				
ICPM (Deg)	x	x			
Left Insertion Gain Error (dB)					x
Right Insertion Gain Error (dB)					x
Left Sweep Max Gain (dB)	x				
Right Sweep Max Gain (dB)	x				
Left Sweep Min Gain (dB)		x			
Right Sweep Min Gain (dB)		x			
Left Polarity	x				
Right Polarity	x				
Left Stereo Channel Assignment	x				
Right Stereo Channel Assignment	x				
Left SNR Weighted (dB)	x				
Right SNR Weighted (dB)	x				
Left Max THD+N (%)	x				
Right Max THD+N (%)	x				

<sup>8</sup> NTSC systems only.

<sup>9</sup> PAL systems only.

<sup>10</sup> IEEE 511

**Table 3–4: The Measurement summaries in the status report (Cont.)**

Measurement	Max	Min	Max-Min	Max Dev	Max Abs
Left Max THD+N 10 dB (%)	x				
Right Max THD+N 10 dB (%)	x				
Left Max THD+N 15 dB (%)	x				
Right Max THD+N 15 dB (%)	x				
Left Max Crosstalk (dB)	x				
Right Max Crosstalk (dB)	x				
Gain Difference (dB)					x
Phase Difference (dB)					x

The Result column (see Figure 3–16 on page 3–27) is color coded in the same manner as the worksheet: green is passing; yellow is Caution; red is Alarm; and white is no limits defined or no measurements made. Blue is an error.

Blue indicates that an error occurred in the measurement, which makes the results invalid. The cell will be blue only if all of the results in the cell are invalid. If any of the results are valid, the cell takes on the color for the worst case valid measurement. If a measurement is invalid, <undefined> is loaded in the Results Displays.

The \* and \*\* column replaces the color information on a monochrome display. The \* symbol means that the measurement was in the caution range, while \*\* means that the measurement was in the alarm range.

Violated Lower Limit is filled in with the lower limit if it was exceeded or Violated Upper Limit is filled in with the upper limit if the Upper limit was exceeded.

The 24 Hour Carrier Level Variation is in the Status Report only if there are at least 4 measurements in the last 24 hours on a single channel, whether or not history is selected. This is the channel with the worst 24 hour Carrier Level variation.

There are two command buttons: View Violations and View Results Detail. The View Violations display is explained next. (Results Detail is explained on page 3–32.)

**View Violations.** Display the View Violations dialog box by choosing the View Violations command button on the Status Report. This dialog box shows all the measurements and channels that are in error. (They have either a single or double asterisk, \* or \*\*.) Only the individual measurements are in this display (see

Figure 3–17). Passing measurements are not shown here, as they are not in violation.

This display is sorted by Alarm/Caution, then channel number, and finally by measurement.

This display can also go to the Results Detail display for a selected cell by using the View Results Detail command button or clicking the right mouse button on the desired cell. (Results Detail is explained on page 3–32.)

Return to the Status Report dialog box by choosing the Close command button.

View Violations						
Channel Table: std.cht Site: Tektronix-Beaverton No View Filter is On				<input type="button" value="Close"/> <input type="button" value="Help"/> <input type="button" value="Print"/>		
Channel	Measurement	Result	z **	Violated Lower Limit	Violate Upper Limit	↑ ↓
2	Aural Carrier Level (dBc)	27.8	**	-17		
2	Aural Frequency Offset (MHz)	4.480599	**	4.495		
2	Carrier to Noise (dB)	15.5	**	43		
2	CSO (dBc)	20.7	**		-51	
2	Differential Phase (Deg)	33.38	**	-10		
2	S/N NTC7 Unweighted (dB)	95.2	**	57		
2	S/N NTC7 Lum Weighted (dB)	5.7	**	54		
2	Line Time Distortion (%)	15.2	**		2	
2	Pulse To Bar Ratio (%)	145.8	**		106	
2	Short Time Distortion (%SD)	7.5	**		3	
2	2T K-Factor (%Kf)	20.1	**		2.5	
2	Lum Non-linear Distort (%)	13	**		10	
2	Chrom. To Lum. Intermod. (IRE)	75.19	**		1	
2	Chrominance Phase (Deg)	72.67	**		1	
2	Chrominance Gain (20 IRE)	47.8	**		21	
2	Chrominance Gain (80 IRE)	114.06	**		81	
2	Multiburst ICR (dB)	4.3	**		2	↓

Figure 3–17: View Violations dialog box

**Results Detail**

The Results Detail dialog box (see Figure 3–18) displays more information about a measurement than can be contained in a cell on the spreadsheet. For example: the FCC Baseband measurement only gives a pass/caution/alarm indication on the spreadsheet. The Results Detail display lists all the measurements under this group, along with the numerical results. You can also view the history of the measurement by using the Next and Previous command buttons.

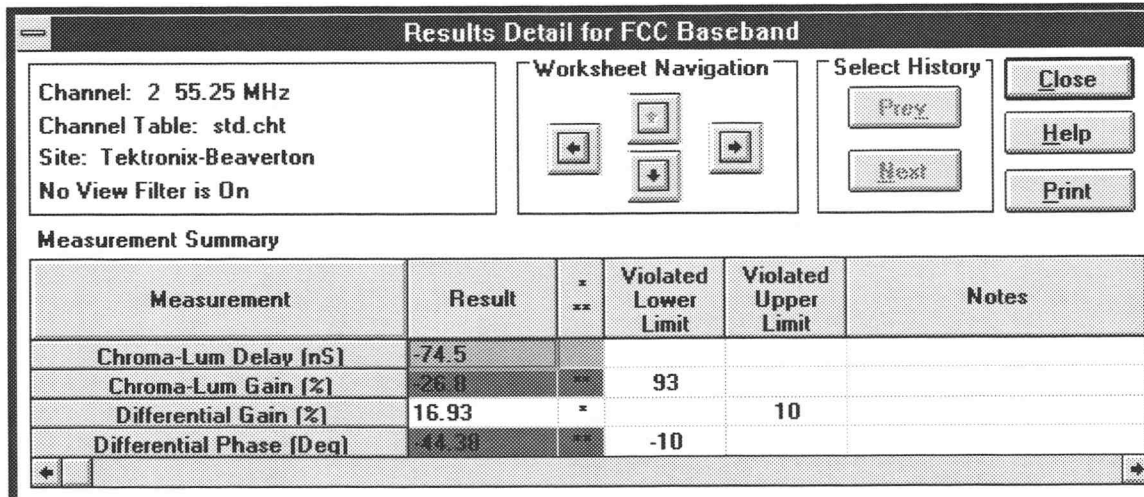

Figure 3–18: Results Detail dialog box

You can get to the Results Detail dialog box many ways:

- Click the right mouse button on a cell in the spreadsheet.
- Press the Results command button on the Button Bar.
- Choose Results Detail from the View menu.
- Choose the View Results Detail command button in the Status Report.
- Click the right mouse button on a cell in the Status Report.
- Choose the View Results Detail command button in View Violations.
- Click the right mouse button on a cell in View Violations.
- Choose the View Results Detail in the Global View.
- Click the right mouse button on a cell in Global View.

**Worksheet Navigation.** Use the four arrows to move around in the spreadsheet while staying in Results Detail. The type of View Filter determines where the

channel and measurement the navigation arrows take you. You cannot move to a channel or measurement that is not displayed.

- Up arrow. Moves up a channel while staying in the same measurement.
- Down arrow. Moves down a channel while staying in the same measurement.
- Left arrow. Stays in the same channel but moves one measurement to the left.
- Right arrow. Stays in the same channel but moves one measurement to the right.

**Select History.** Use these command buttons to display measurement history:

- Prev. This command button selects the previous measurement results (history).
- Next. This command button selects the next most recent measurement (history).

**Measurement Summary.** The summary lists the results for each measurement:

- Measurement. Lists the measurements contained under the Measurement Header in the spreadsheet. For example, FCC Baseband has Chrominance to Luminance Delay, Chrominance to Luminance Gain, Differential Gain, and Differential Phase.
- Result. Lists the numerical results of a measurement.
- \* \*\*. Flags whether a given measurement was in violation of either the Caution limits (\*) or the Alarm limits (\*\*).
- Violated Lower Limit. If the results violated the lower limit defined by the Limits file, then the limit is printed in this column.
- Violated Upper Limit. If the results violate the upper limit defined by the Limits file, then the limit is printed in this column.
- Date/Time. Date and time of the measurement. This comes from the internal clock of the instrument making the measurement, unless the measurement is invalid (an error), then the time comes from the PC. (Use the horizontal scroll bar to view this column.)
- Test ID. The Test ID when the measurement was made. (Use the horizontal scroll bar to view this column.)
- Notes. Notes from the test equipment about how a measurement was made. Only one note is available for each cell, so it is replicated for each measurement within a cell. Table 3–5 lists the notes that the instruments (either the

271X or the VM700A) place in the Notes field for each of the different measurements.

If the measurement cannot be made, the instrument name, a colon and an event number (error number) appears in the Notes field (that is, 271X E:###). Use the event number to cross reference to the instrument documentation (the *2714 and 2715 Spectrum Analyzer Programmer Manual*) to find out what failed during the measurement.

**Table 3–5: Explanation of the Notes Field notes**

Measurement	Notes field <sup>1</sup>	Meaning
Visual Carrier Level	sddd.d dB ext ofst <sup>2</sup>	External attenuation or amplification in dB
Visual Carrier Frequency	—	
Aural Carrier Level	—	
Aural Frequency Offset		
Average Power	sddd.d dB ext ofst <sup>2</sup>	External attenuation or amplification in dB
Carrier to Noise	sddd.dZ ddd.dZ * <sup>3</sup>	Noise Bandwidth and Noise Frequency (in Hz) and 2 dB flag <sup>4</sup> G if gated
Desired to Undesired	ddd.dZ * <sup>3</sup>	Noise Bandwidth (in Hz) and 2 dB flag
CSO	#Loc * #Loc * Example: 1A* 3R* 4R* <sup>3</sup>  #Loc #Loc #Loc * <sup>3</sup>	Stored only  Interactive only  Beat number, location type, and 2 dB flag <sup>4</sup>
CTB	Same as CSO	Beat number, location type, and 2 dB flag
Cross Modulation	—	
Adjacent Channel Leakage	* <sup>3</sup>	2 dB flag
In-Channel Response <sup>5</sup>	sddd.dZ/sddd.dZHz RF(or BB) G### <sup>6</sup>	Min/Max Frequency Offset and signal type (RF or Baseband) G### is the line number of the test line
Hum/LFD	60 Hz (or 50 Hz) Power	Line Frequency
FCC Baseband	—	Any note is from the VM700A
Modulation Depth	RF (or BB)	Signal Type
Aural Deviation	—	
Signal to Noise	—	Any note is from the VM700A

Table 3-5: Explanation of the Notes Field notes (Cont.)

Measurement	Notes field <sup>1</sup>	Meaning
Waveform Distortion	—	Any note is from the VM700A
Multiburst	Multiburst NTC-7 Combo or FCC Multiburst	The VM700A either used the NTC-7 Combination signal or the FCC Multiburst signal to make this measurement
ICPM	—	Any note is from the VM700A
Audio	—	Audio Limits file selected in the VM700A unless there is a note from the VM700A

<sup>1</sup> s = sign (+ or -)  
d = decimal number  
Z or ZHz = frequency (Hz) in engineering notation (kHz or MHz)  
# = 1 -5  
Loc = A(bsolute) or R(elative)  
RF or BB = signal Type RF or Baseband

<sup>2</sup> This note is not available for stored measurements retrieved from the 271X.

<sup>3</sup> If an asterisk is present, the measured value is within 2 dB of the analyzer noise floor. The actual value may be better than the one indicated.

<sup>4</sup> The results of the Carrier to Noise and CSO measurements may be 1000 larger than measurement. This indicates that the Quiet Lines measured were no longer quiet at the end of the test. The true answer may be better than the one indicated.

The results of the Carrier to NOise and CSO measurements may also be 2000 larger than measured. This indicates that the mixer level was raised above the optimum to allow the video modulator board to work. The true answer may be better than the one indicated.

Note also that the 1000 and 2000 flag are additive, so the result could be 3000 above what was measured indicating that both conditions occurred.

<sup>5</sup> The RF or BB signal type indicator may not appear if both offset frequencies are negative. The In-Channel Response Frequency range is not available for stored measurement retrieved from the 2714.

<sup>6</sup> G### is only inserted from the 2715.

**Exceptions.** The Results Detail display generally only gives the results for a single cell; the exception to this is for the first six cells: the Visual and Aural Carrier Levels and Frequencies. These measurements are grouped together into one Results Detail display. Also if there are four or more of the measurements made in the last 24 hours, then a summary of the Carrier Levels measurements over the past 24 hours is provided. The summary includes the total visual carrier level variation and each individual measurement value with a Time/Date stamp. (See Figure 3-19.)

Measurement	Result	· **	Violated Lower Limit	Violated Upper Limit	Notes
Variation (dB)	42.7	**		8	
Visual Carrier Level (dBmV)	40				
Visual Carrier Level (dBmV)	26.1				
Visual Carrier Level (dBmV)	8.2				
Visual Carrier Level (dBmV)	-2.4				

Figure 3–19: The 24 hour Carrier Summary display

### Measurement and Channel Summaries

Select an entire spreadsheet row or column, choose the Results command button (or click on the Measurement or Channel Header with the right mouse button), then you can access special displays called Channel Summary (row selected) or Measurement Summary (column selected). (A right mouse click on the Channel or Measurement Header name also accesses these reports.) These displays are a cross between Status Reports and Results Detail displays. The View Filter affects these displays. Information in hidden rows or columns is not contained in the Measurement or Channel Summaries. The results contained in the measurement history can also be incorporated into these summaries.

The Channel Summary (see Figure 3–20) displays violations for the selected channel. You can move to a different channel by using the Select Channel navigation arrows. You can also select a cell and view the Results Detail for the measurement for that channel.



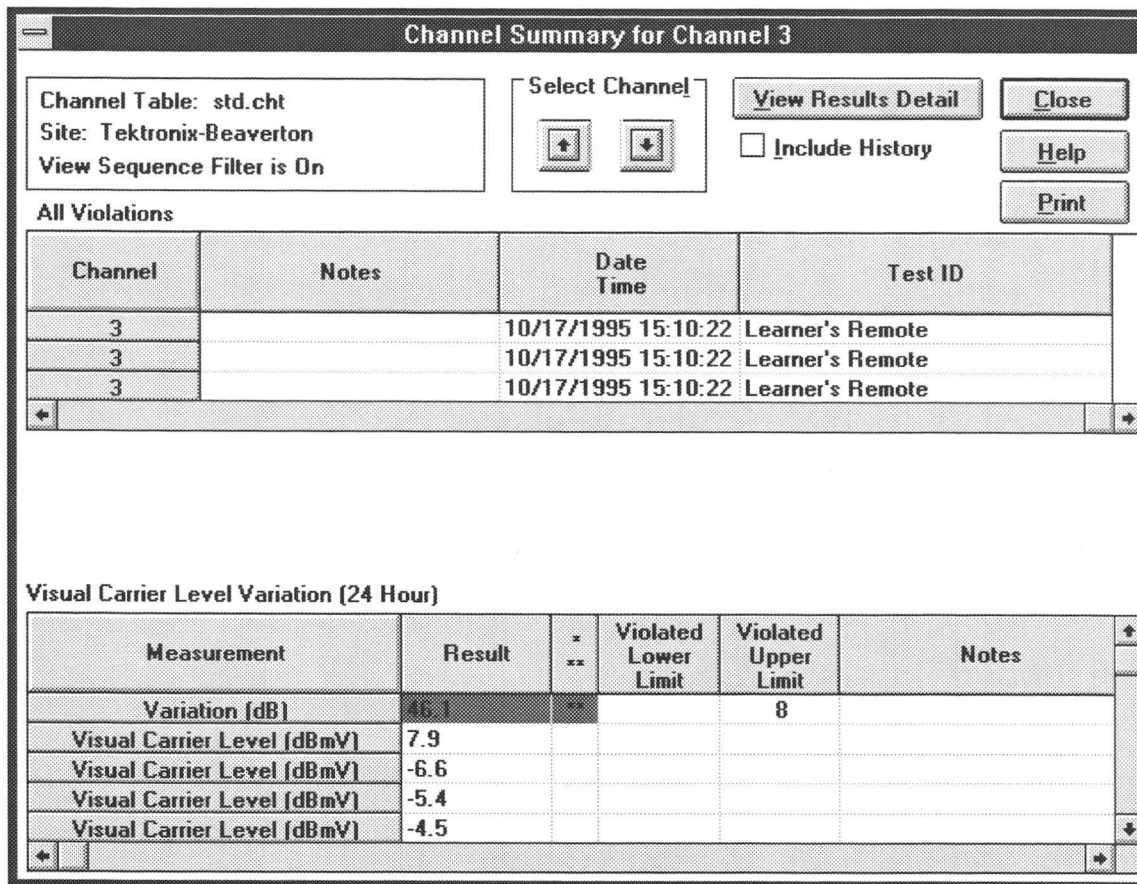

Figure 3–20: Example of a Channel Summary

The example in Figure 3–20 gives the Visual Carrier Level Variation. This information is always present in a Channel Summary if there are four Visual Carrier Level measurements in a 24 hour period, regardless of whether or not Include History is selected.

The Measurement Summary (see Figure 3–21) gives the Status Report information for just the selected measurement. You can move to other measurements using the Navigation arrows. The View Violations command button will go to the View Violations display for only the selected measurement. The View Results Detail command button goes to the Results Detail display for the selected channel measurement. If the Include History check box is checked, then the worst case of the measurement in this worksheet is displayed. Otherwise, the worst-case current measurement results are displayed.

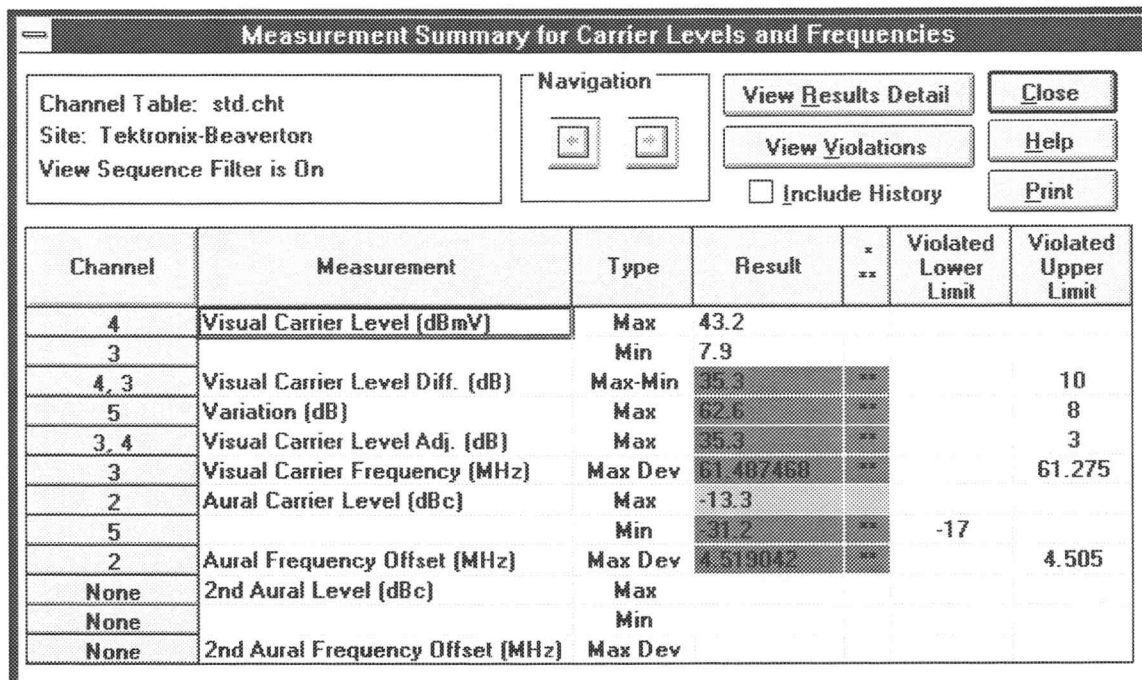

Figure 3–21: Example of a Measurement Summary

**Global View** This is a condensed view of the standard spreadsheet display (see Figure 3–22). All of the measurements and channels are in the same order as the spreadsheet. This view allows for a quick overview of how the system is doing as a whole. White blocks indicate that there are no defined limits, or no measurement results. Green blocks mean the measurement is passing. Yellow blocks indicate that the measurement is in the Caution range. Red blocks indicate that the measurement has violated the Alarm limits. Blue means that an error occurred in making the measurement and the results are invalid. Gray means that the measurements are not permitted because that channel was not included in the Channel Table transfer to the instrument (RF measurements are not permitted if a channel is not included in the transfer) or the measurement cannot be performed on that channel (analog-only measurement cannot be taken on digital channels and digital-only measurements cannot be taken on analog channels). Please see Appendix C, *Channel Table Editor*, for more details on this Channel Table field.

The screenshot shows a dialog box titled "Global View". At the top left, it says "No View Filter is On". On the top right, there are buttons for "Close" and "Help". Below these is a button labeled "View Results Detail". The main area is a grid with the following columns: Vis Car Lev, Vis Car Frq, Aur Car Lev, Aur Car Frq, 2nd Aur Lev, 2nd Aur Frq, Avg Pwr, C / N, D / U, C S O, C T B, X Mod, A C L, I C R, H U M, FCC BB, Mod Dep, Aur Dev, S / N, and Wfm Dis. The rows are numbered 2 through 22, with a gap between 22 and 7, and then 8. The grid cells are shaded in various colors (white, gray, green, yellow, red, blue) to represent different measurement statuses. For example, row 2 has a white cell for Vis Car Lev and a gray cell for Vis Car Frq. Row 3 has a white cell for Vis Car Lev, a yellow cell for Aur Car Lev, and a gray cell for Aur Car Frq. Row 4 has a white cell for Vis Car Lev, a gray cell for Aur Car Lev, and a white cell for Aur Car Frq. Row 5 has a white cell for Vis Car Lev, a gray cell for Aur Car Lev, and a white cell for Aur Car Frq. Row 6 has a white cell for Vis Car Lev, a gray cell for Aur Car Lev, and a white cell for Aur Car Frq. Row 95 has a white cell for Vis Car Lev, a gray cell for Aur Car Lev, and a white cell for Aur Car Frq. Row 96 has a white cell for Vis Car Lev, a gray cell for Aur Car Lev, and a white cell for Aur Car Frq. Row 97 has a white cell for Vis Car Lev, a yellow cell for Aur Car Lev, and a white cell for Aur Car Frq. Row 98 has a white cell for Vis Car Lev, a gray cell for Aur Car Lev, and a white cell for Aur Car Frq. Row 99 has a white cell for Vis Car Lev, a gray cell for Aur Car Lev, and a white cell for Aur Car Frq. Row 14 has a white cell for Vis Car Lev, a yellow cell for Aur Car Lev, and a white cell for Aur Car Frq. Row 15 has a white cell for Vis Car Lev, a gray cell for Aur Car Lev, and a white cell for Aur Car Frq. Row 16 has a white cell for Vis Car Lev, a yellow cell for Aur Car Lev, and a white cell for Aur Car Frq. Row 17 has a white cell for Vis Car Lev, a gray cell for Aur Car Lev, and a white cell for Aur Car Frq. Row 18 has a white cell for Vis Car Lev, a gray cell for Aur Car Lev, and a white cell for Aur Car Frq. Row 19 has a white cell for Vis Car Lev, a gray cell for Aur Car Lev, and a white cell for Aur Car Frq. Row 20 has a white cell for Vis Car Lev, a yellow cell for Aur Car Lev, and a white cell for Aur Car Frq. Row 21 has a white cell for Vis Car Lev, a gray cell for Aur Car Lev, and a white cell for Aur Car Frq. Row 22 has a white cell for Vis Car Lev, a yellow cell for Aur Car Lev, and a white cell for Aur Car Frq. Row 7 has a white cell for Vis Car Lev, a gray cell for Aur Car Lev, and a white cell for Aur Car Frq. Row 8 has a white cell for Vis Car Lev, a gray cell for Aur Car Lev, and a white cell for Aur Car Frq.

Figure 3–22: Global View dialog box

Access the Result Detail display along with the Channel and Measurement Summaries (see page 3–32) from the Global View by selecting a cell, a row, or a

column and clicking the right mouse button. You could also use the View Results Detail command button.

Access the Status Report from the Global View by clicking the right mouse button at the intersection of the Measurement and Channel header.

### **2714/2715 Screen**

The 2714/2715 Screen command displays a copy of what is presently on the 271X screen. This includes displayed traces and readouts.

---

**NOTE.** Place the analyzer in Single Sweep mode and be sure the current sweep is complete before requesting a 2714/2715 Screen. If the analyzer is not in Single Sweep mode and the current sweep is not complete, there may be inconsistencies between the marker readout text, the marker positions, and the waveforms, because the analyzer updates these values asynchronously with respect to the query for the values.

---

### **Picture**

The Picture command displays a video picture of what is presently on a given channel (shows a complete active picture). To use the Picture command, you must have a video board and software driver installed in your PC. (The CSS500 package does not include the video board and driver). This default driver is the Video Blaster. The video board and driver must be active when the Picture command is called. The displayed picture is the video source connected to the video board.

The CSS500.INI file must be edited if any driver other than the Video Blaster is used. The line "Video Driver=XXXXXX" in the CSS500.INI file must have the XXXXXX changed to match the title that appears in your video driver's Title Bar.

Any other details about the operation of Picture are controlled by your video driver.

Use ALT+TAB to jump between the video driver application and CSS500.

### **Measurements and Channels**

This is a View Filter that determines which channels and measurements are on the spreadsheet (see Figure 3-23). There are All and Select options for both measurements and channels. You can select whatever measurements and channels are important to view at the moment without "losing" any measurements. This allows you to configure the spreadsheet to show only what you need to see at the moment and eliminate all extraneous information without deleting anything. All View Filters are mutually exclusive.

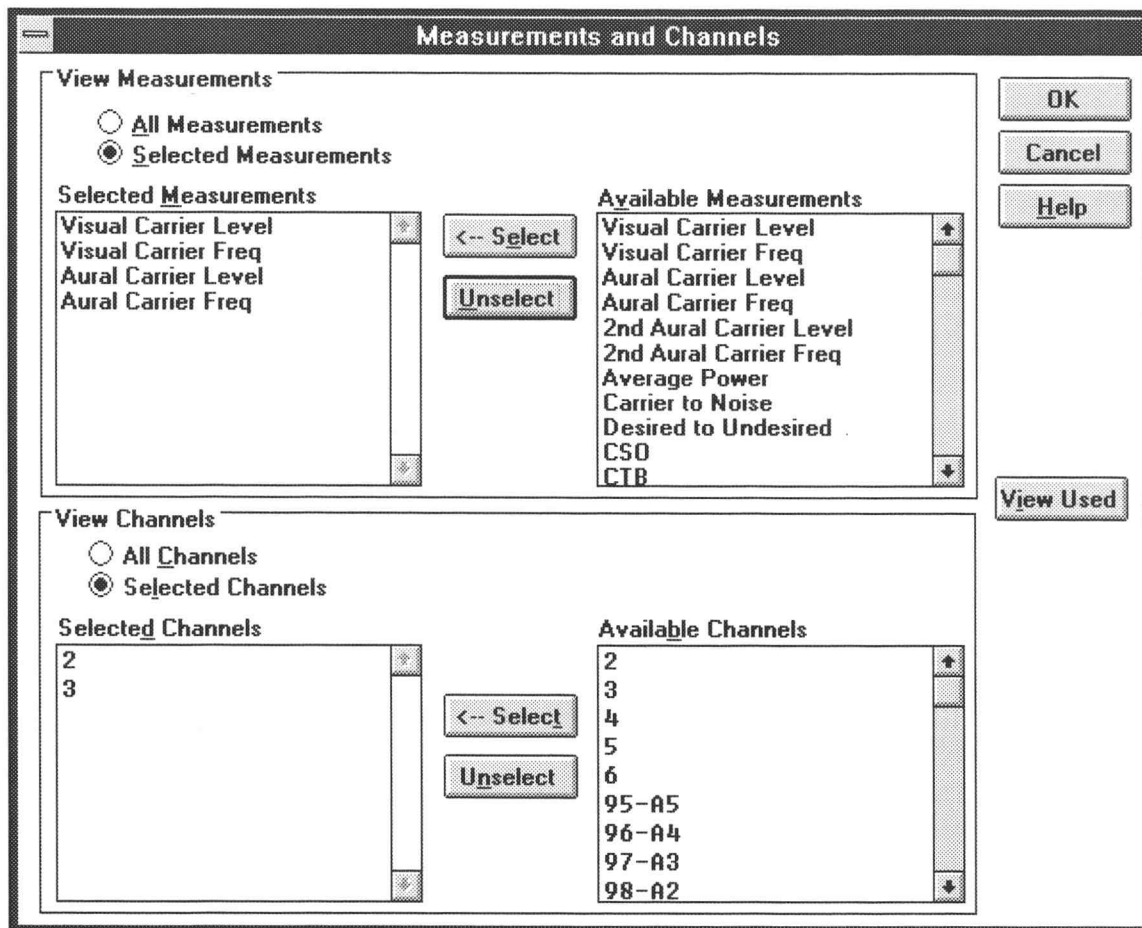

Figure 3-23: The Measurements and Channels dialog box

The View Filter status box displays the following message when this filter is on: View Selected Filter is On. The spreadsheet looks like Figure 3-24 when the Measurement and Channel View Filter is selected as shown in Figure 3-23.

The screenshot shows the Tektronix CSS500 software interface. At the top is a menu bar with options: File, Edit, View, Measure, Configure, Execute, Help. Below the menu bar are several buttons: Open, Save, Global, Results, Status, Meas Set, Meas Seg, Test ID, Setups, Limits, Print. The main area displays the following information:

Worksheet: <untitled> Site: Tektronix-Beaverton  
 Chan Table: std.cht Test ID: Learner's Remote View Sequence Filter is On

	Visual Carrier Lev (dBmV)	Visual Carrier Freq (MHz)	Aural Carrier Lev (dBc)	Aural Frequency Offset (MHz)	Carrier to Noise (dB)	CSO (dBc)	CTB (dBc)
2 55.25	30.3	55.527825 **	-12.2	4.516292 **	21.4 **	-20.3 **	-20.1 **
3 61.25	-2.2	61.325103 **	-36.2 **	4.497509	65.9	-26.3 **	-33.9 **
4 67.25	22.9	67.071183 **	-14.9 *	4.504166 *	37.1 **	-28.7 **	-30.3 **
5 77.25	40	77.382545 **	-17.4 **	4.495005 *	21.1 **	-25.7 **	-68.7

Figure 3-24: Worksheet with Measurements and Channel View Filter on

To turn this View Filter off, select the Measurements and Channels command from the View menu.

---

**NOTE.** You cannot select a measurement or channel unless it is viewable. Therefore, if only some channels and measurements are in view and the Select All command (from the Edit menu) is used, the “hidden” measurement cells are not selected. The exception to this rule is the Carrier Level and Frequency measurement. If you select one of the six measurements, all these measurements are made, whether they are visible or not.

If you select all channels, by clicking on one of the Carrier Level and Frequency Measurement headers and the Average Power header, you are still given the option to do a Carrier Survey, even if all channels are not viewable.

---

When you return to All for the Measurements and Channels options, the list of selected measurements and channels remains. You can toggle between the filtered and full display quickly.

If the View Filter is on and you are trying to Import results that would enter a hidden row or column, you are warned that all of your imported results are not immediately viewable.

You can switch to any other View Filter by choosing it from the View menu.

There is a special command button, View Used, for this dialog box. This command allows you to automatically filter off all channels and measurements that have no results. View Used is particularly useful for printing out worksheets.

Use this command button immediately before printing reports to minimize the amount of blank space.

---

**NOTE.** *The View Filters also affect the Status Report, Measurement Summaries, Channel Summaries, and the Results Detail display.*

---

## Measurement Sequence Results

When this filter is active, only those measurements made with the most recent Measurement Sequence execution are on the spreadsheet. The measurements displayed are not necessarily the current Measurement Sequence. (See page 3–56 for how to define a Measurement Sequence.) For example, if you have defined and executed a Measurement Sequence that only measures the Signal to Noise Ratio for four select channels, then only those four channels' S/N measurements are displayed on the spreadsheet when this View Filter is on. The rest of the measurements are only hidden. They are still part of the worksheet and are available as soon as the Measurement Sequence Results filter is switched off.

If no measurements on the worksheet are associated with a Measurement Sequence, then you will get a warning message (see Figure 3–25) telling you that there are no measurement results associated with a Measurement Sequence and therefore the View Filter will not be applied.

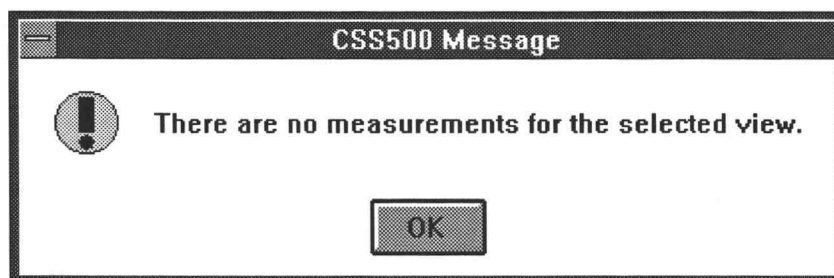

**Figure 3–25: Warning message**

The View Filter status box has the message View Sequence Filter is On, and there is a check mark in front of Measurement Sequence Results in the View menu. To turn the View Filter off, just choose Measurement Sequence Results from the View menu again, or choose any other View Filter.

The following is a list of commands that are disabled when the Measurement Sequence View Filter is on:

- Import, from the File menu
- Current Selection from the Measure menu and Meas Sel from the Button Bar

- Double click on a cell to make a measurement
- Get Stored Results from the 2714/2715, from the Measure menu

These commands are disabled because the results are not immediately viewable.

You can switch to any other View Filter by choosing it from the View menu.

### Test ID Results

This View Filter only displays cells that have measurements tagged with the currently displayed Test ID. Therefore, if only a few of the measurements on the current worksheet were made under the current Test ID, then only those few measurements are displayed. If no measurements on the worksheet were made under the current Test ID, then CSS500 displays a warning message that there are no measurements with that Test ID and will not apply the Test ID filter. (This is the same warning message as Measurement Sequence Results.) Select the Test ID using the Configure menu. (See page 3–52.)

If the Test ID View Filter is on, then the View Filter Status Box contains the message View Test ID View Filter is On. There is also a check mark in front of Test ID Results in the View menu. To turn the Test ID View Filter off, choose Test ID Results from the View Menu again or choose another View Filter.

If the Test ID Results View Filter is on and you are trying to import results that would enter a hidden row or column, you are warned that all of your imported results are not immediately viewable.

You can change which Test ID you are viewing. In the Test ID dialog box, select one of the Used in Worksheet Test IDs and the View Filter will automatically switch to that Test ID. You can only select from the Used in Worksheet Test IDs.

### Row Header Fields

The Row Header Fields command allows you to select what information is given in the Channel Header (see Figure 3–26). You can display the Channel Number & Tag, the Program Name, and/or the Channel Frequency. You must select at least one. Initially all three options are always chosen. When all three are selected, the Header column width is slightly larger than if one or two of the options is selected.

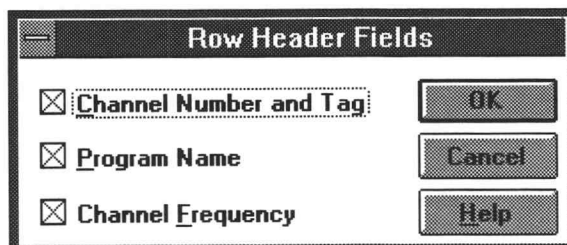

Figure 3–26: The Row Header Fields dialog box



---

**NOTE.** There is no Program Name for any channel in any Channel Table as shipped from Tektronix. Use the Channel Table Editor to add the Program Names as needed.

---

## Measure

The Measure menu (see Figure 3–27) is used to make measurements, tune the demodulator and the 2714/2715 to a specific channel, and recall results from 2714/2715.

<b>Measure</b>
<b>C</b> urrent Selection <b>S</b> equence
<b>T</b> une to Channel
<b>G</b> et Stored Results from 2714/2715...

**Figure 3–27: The Measure menu**

### Current Selection

The Current Selection makes the measurements for the selected cells. This is true with the exception of the Visual, Aural Carrier Level, and Frequency cells. Select any of these measurements and all six are performed for the channel. To perform all measurements for a single channel, select the entire row. Conversely, if you want one measurement for all channels, select the entire column. This is the same as Meas Sel from the Button Bar (see page 3–86). For a single cell, you can achieve the same result as Current Selection by double-clicking on the cell with the left mouse button. For a single row or column, you can achieve the same results by double-clicking on the measurement or channel name.

If at least one of the Carrier Levels and Frequencies measurements (Visual Carrier Levels, Visual Carrier Frequency, Aural Carrier Level, Aural Frequency Offset, Second Aural Carrier Level, or Second Aural Frequency Offset) is selected for all analog channels and Average Power measurements are selected for all digital channels, CSS500 presents a message to allow the user to do a Carrier Survey instead of a series of individual carrier level and Average Power measurements. The advantages and disadvantages of selecting the Carrier Survey are:

Advantage:

- Faster measurement execution

Disadvantages:

- The Pause For New Channel preference will not pause for new channels within the survey
- All measurement results are tagged with the same date and time
- The CSS500 display is not updated until the survey is finished. (You might think that the software has crashed.)

Whether you select individual measurements or the survey, the measurements will still be made in the mode specified in the Measurement Setups dialog box.

### **Sequence**

If a Measurement Sequence is available (see *Measurement Sequence*, page 3–56) then selecting Sequence performs the Measurement Sequence. This is the same as the Meas Seq command button on the Button Bar (see page 3–86).

Note that the computer is not strictly dedicated to CSS500 while performing a Measurement Sequence. You can switch to other applications while a Measurement Sequence is running by sizing the CSS500 window so that other application icons are visible. Start the Measurement Sequence then click on another icon. If you select a DOS-based application that does not share memory, the sequence will not be able to run until you exit that application.

For example, you can size the CSS500 window so that it only takes half of the window and Excel so that it takes up the other half. You can run a Measurement Sequence in one half and process results from a previous Measurement Sequence on the other half while monitoring the results from the current Measurement Sequence.

### **Tune to Channel**

Tune to Channel tunes the selected demodulator and the 271X to the selected channel. It will also set the Channel Table in the instrument, if it is not already active. Select the channel by selecting a cell from the desired channel, then choose Tune to Channel. It will report an error if the channel cannot be tuned.

### **Get Stored Results from 2714/2715**

Use this menu item (see Figure 3–28) to retrieve all the CATV measurement results currently stored in the NVRAM of the connected 2714 or 2715. The Notes field is not as complete as if it was done directly from the CSS500 application. The results are not erased from the 271X memory after they are retrieved. Results can only be erased using specific 271X front panel keystrokes.

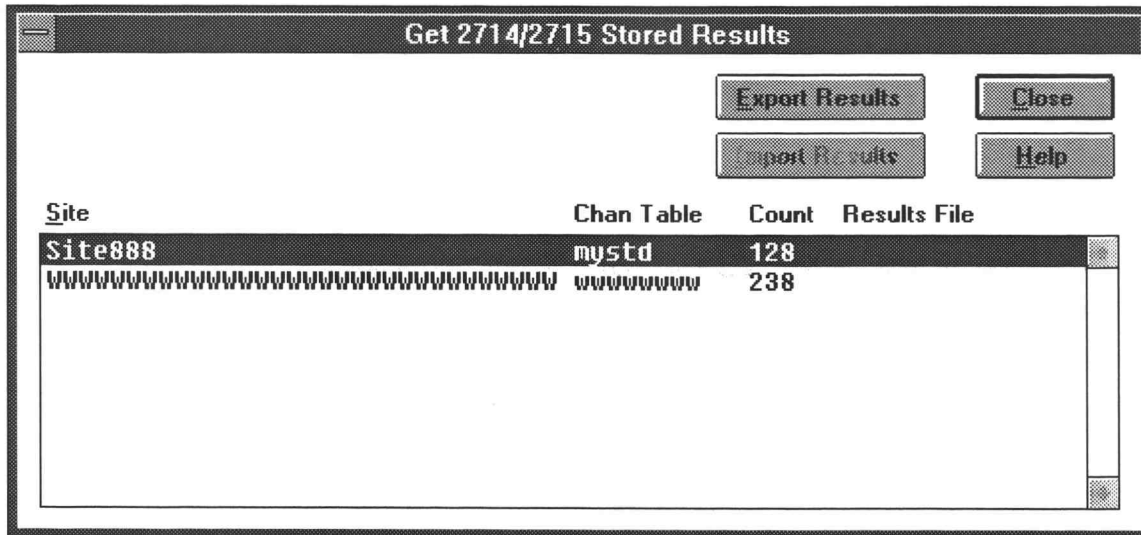

Figure 3–28: The Get Stored Results dialog box

Since results from the 271X can come from multiple Channel Tables and Sites, the measurement results are grouped according to Site and Channel Table name. Ordering within the directory is alphabetical by site name. Count is the actual number of measurement results contained in the group specified by the Site and Chan Table columns. Results File is the name of the results file to which a particular group of results has been exported.

Use the Export Results command button to export the results from the instrument's NVRAM into a results file, \*.wsr. Use the Import Results command button to bring the results file into a CSS500 worksheet.

When the Export is complete there will be a ".wsr" file in the Results File Column in the Get Stored Results dialog box. This file is ready to be imported into a worksheet.

The Import Results dialog box (see Figure 3–29) gives several choices of how the data is imported into the worksheet:

- Exact channel information match only
- Use blank channel information as wildcards
- Verify mismatched channel information

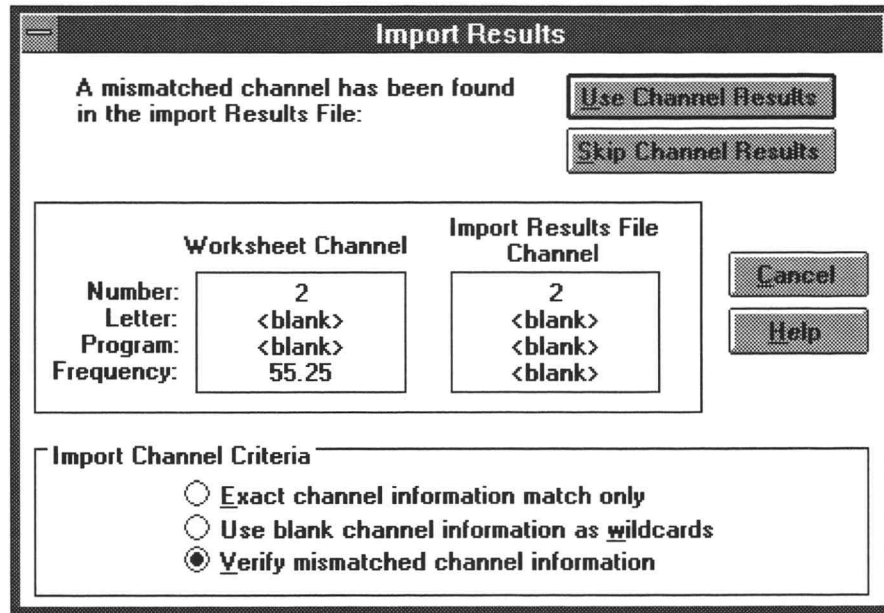

Figure 3–29: The Import Results dialog box

The top two choices will automatically load as much data as it can without any user intervention. The last option allows you to check and verify all information before loading any data.

Generally, when using Import to get results from an instrument into a worksheet, “Use blank channel information as wildcards” is the most efficient option since there will rarely be an exact match. This is because the instrument only stores the channel number as the channel ID, while CSS500 stores the channel number, program name, and nominal visual carrier. You could go through and verify each channel if desired, to make sure that the channel numbers match, but generally, the “Use blank channel information as wildcards” selection would be the most efficient way to load the data, because it will reduce further prompts.

---

**NOTE.** *If any of the results that you are importing contain results from CSO or CTB measurements, you may end up importing more results than listed in the results column because of the way that CSS500 distinguishes results. (True with older firmware versions of the 2714.)*

*Any cell without results data or in Error condition will not be imported. Cells that have more than one measurement will have all valid data imported and the Error data results left blank.*

---

If you are Importing results from a Channel Table that has mismatches in the Channel Header, you are flagged during the import process so that you are aware

of any problems and can fix them. The only exception to this is if the Channel Number does not exist in the import worksheet Channel Table. In this case, you are warned at the end of the import process with the message given in Figure 3–30.

If you are importing results from a channel table that has mismatches in the channel header, no destination channel, an inactive destination cell, or a user requested skip, you are warned at the end of the import process as shown in Figure 3–30.

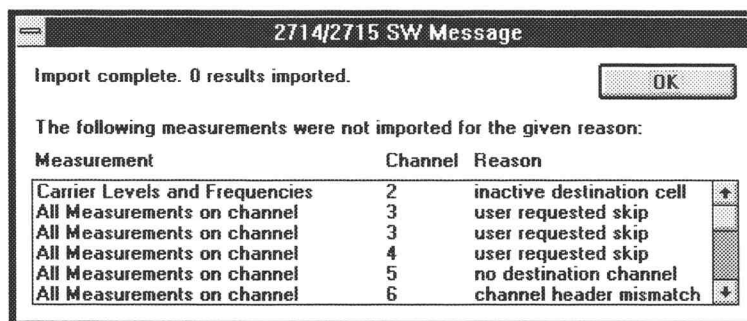

Figure 3–30: Imported results messages

## Configure

Use the Configure menu (see Figure 3–31) to set up worksheets, measurements, and test equipment.

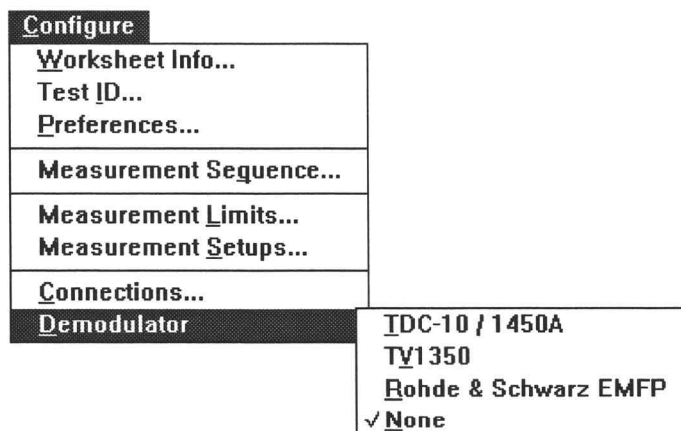

Figure 3–31: The Configure menu

**Worksheet Info**

Worksheet Info edits the Site, Channel Table, and description for the current worksheet. (See Figure 3–32.)

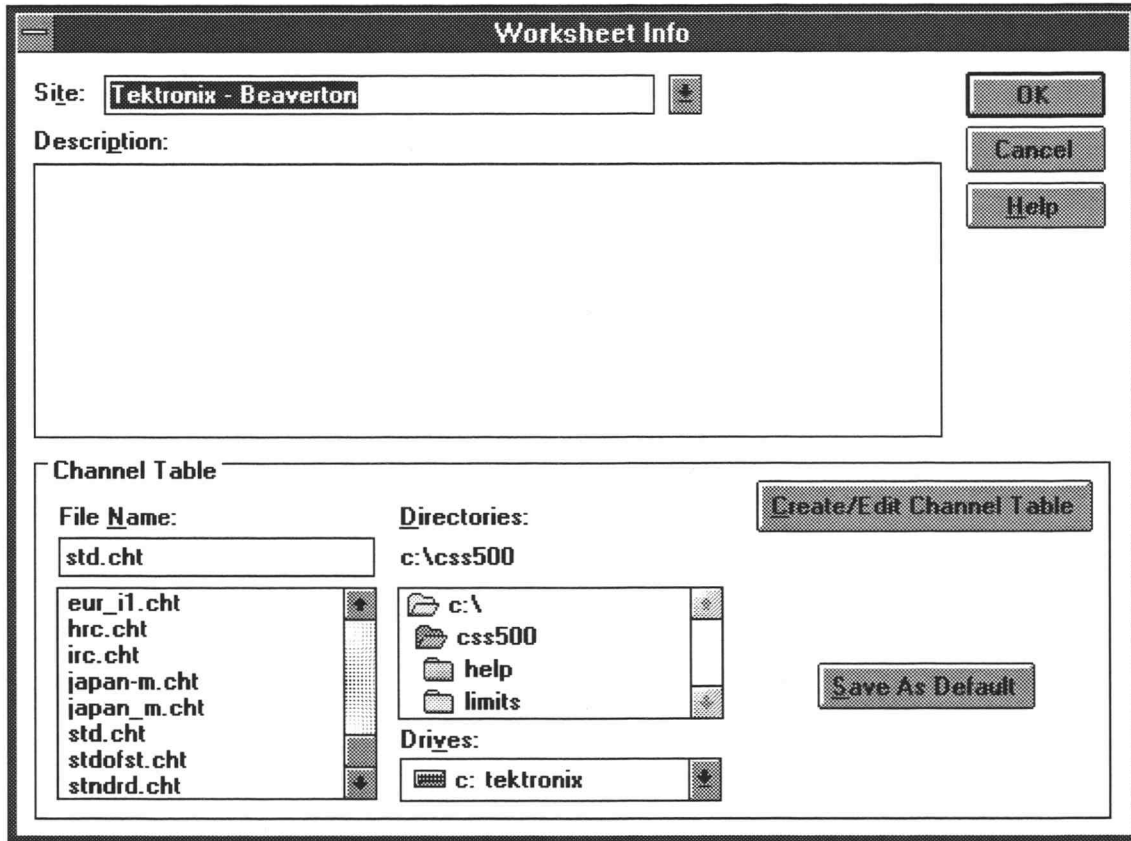

Figure 3–32: The Worksheet Info dialog box

**Site.** The Site combo box defines the location where the measurements are made. Only one Site is allowed per worksheet. If you change the Site, you are queried whether you want to save the worksheet under a new name or overwrite the old Site name. If you choose to overwrite the old name all of the history previously collected under the old Site name will now be tagged with the new Site name.

<Undefined> is an acceptable Site name. “Blank” (nothing in the field at all) is not acceptable and an error message will appear if “blank” is in the Site field.

**Channel Table.** This associates a certain Channel Table with a worksheet. The Channel Table is a list of all of the available channels, their frequency, their program name, etc. Only one Channel Table is allowed per Worksheet. If you want to change the Channel Table, start with an empty worksheet.

**Create/Edit Channel Table.** See Appendix C for more information on editing the Channel Table. Edit the Channel Tables with caution; see the warnings in Appendix C.

**Save as Default.** This command button allows you to save the Channel Table in the combo box as the default Channel Table. When starting the CSS500 software, the default Channel Table loads automatically.

**Description.** Put any information that might be relevant into this field. How the measurements were made, the serial numbers of the equipment used, who did the measurements, and the dates are examples of things that you might want to load into this field. This field is limited to 500 characters. Carriage returns are allowed.

Use this field is to meet the FCC documentation requirements by entering:

- Identification of instruments (make, model, most recent calibration date)
- Description of procedures utilized
- Statement of qualifications of the person(s) performing the tests

The field is fully editable. The information can be copied to the clipboard using CNTRL+INSERT or CNTRL+C, and then attached to the worksheet name cell in Excel as a text note.

**Test ID** Use the copyThe Test ID is the name of the operator, test point, or whatever identifier is most appropriate. The Test ID dialog box consists of a combo box and a list box: All Test IDs and Worksheet Test ID (see Figure 3–33). All Test IDs lists all of the Test IDs that have ever been used. Enter new Test IDs here. Worksheet Test IDs are the IDs used in the current worksheet.

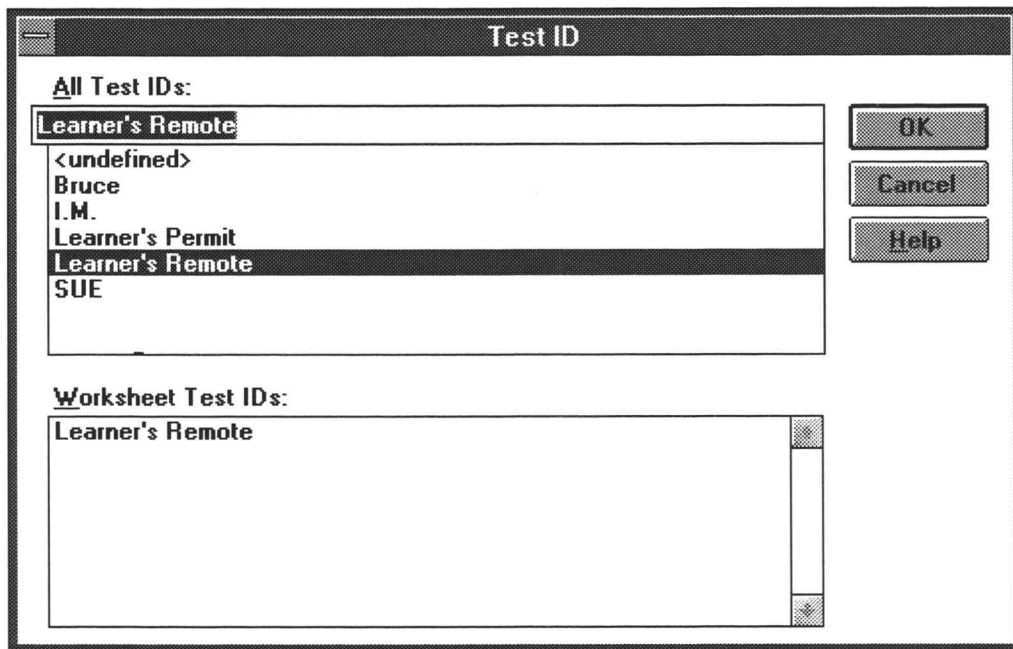

Figure 3–33: The Test ID dialog box

Use this field to flag certain measurements and then use the View Filter, so only cells that have a measurement associated with the selected Test ID are displayed. To quickly change the Test ID you want to filter, select the Test ID from the Worksheet Test IDs group and the View Filter will switch to that Test ID.

Also change the Test ID using the Test ID command button from the Button Bar (see page 3–86).

**Preferences** This dialog box (see Figure 3–34) sets the way results are collected and displayed.



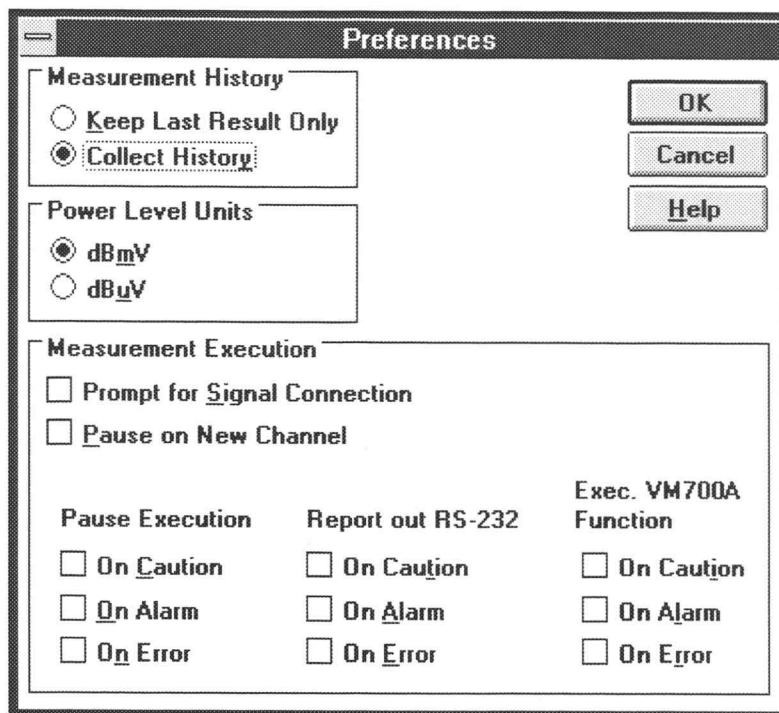

Figure 3-34: The Preferences dialog box

**Measurement History.** History (the previous measurement results) can be collected or only the most recent measurement saved. If History is turned off and then turned back on, the measurements are saved beginning with the current measurement displayed on the worksheet. Turning history off does not erase any results previously stored when history was on. For an illustration of how this works, see Figure 3-35.

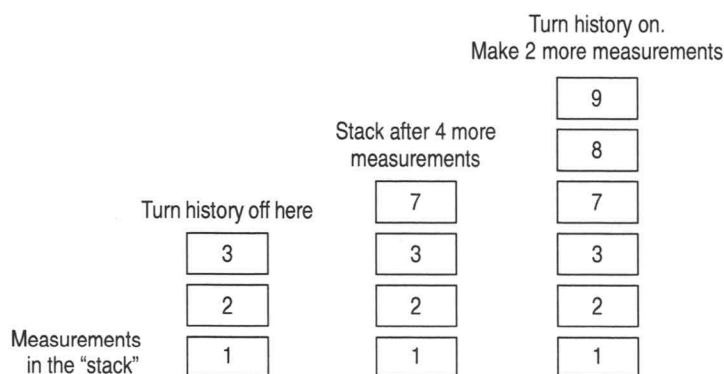

Figure 3-35: How measurements are saved when history is turned off, then on

**Power Level Units.** Choose one of the two formats to display the Visual Carrier Level and Average Power units:

dBmV [referenced to 1 mV ( $10^{-3}$  volts)]

dBuV [referenced to 1  $\mu$ V ( $10^{-6}$  volts)]

**Measurement Execution.** These check boxes determine whether the measurements will stop and flag certain conditions, and how you are notified of these conditions.

The first option is Prompt for Signal Connection. It is used if your RF feed to the test equipment is on a switch instead of a splitter. If it is on a switch you need to be able to switch the RF feed into either the 271X or the TDC-10 (TV1350 or EMPF) as needed. If this check box is selected, CSS500 also changes the measurement order from: left to right then top to bottom — to: left to right and top to bottom for the RF measurements, then left to right and top to bottom for the baseband measurements. This is done so that the user only has to change the connection once.

The second option is Pause on New Channel. It is used when the pre-selector needs to be tuned for each channel or some other manual adjustment needs to be done whenever the channels change.

The third option is a set of options that determine how non-standard conditions are treated. The “non-standard” conditions include: measurement results in Caution, Alarm, or Error. The Caution and Alarm conditions are set through the limits file that is associated with a particular channel. The Limit files are set using the Measurement Limits command from the Configure menu. See page 3–64 for more information on the Measurement Limits. The Error condition only occurs if a measurement cannot be made or the measurement results from the instrument are out of the allowable range.

The ways these “non-standard” conditions could possibly be handled include: Report out RS-232, Execute VM700A Function, or Pause Execution.

Pause Execution is appropriate for user interactive measurements. You can watch it make the measurements and fix any problems that occur. If the measurements are stopped because this is set, you have two choices: OK continues making measurements; Cancel drops out.

The Execute VM700A Function calls one VM700A function: CSS500~ALARM\_ON. When this is enabled and a flagged condition occurs, a specific function within the VM700A is executed for alarm activation, CSS500~ALARM\_ON. This default function is loaded in the VM700A as required. First, CSS500 attempts to play back the appropriate function. If there is no function by that name, then the default function is loaded into the VM700A. The default function controls the relay switch located on the back of the VM700A between the two RS-232 ports. CSS500~ALARM\_ON closes the relay.

---

**NOTE.** Older versions of the CSS500 software did not have as many options for non-standard conditions, so some things were treated differently. If Pause on Alarm was selected in these versions, two VM700A functions were called: CSS500~ALARM\_ON and CSS500~ALARM\_OFF. The newer versions of the software only calls CSS500~ALARM\_ON. The older versions called CSS500~ALARM\_OFF when the user “un-paused” the system after an alarm. Therefore, when upgrading to a new version make sure that you manually reopen the relay on the VM700A, if you are using the default function. The other option is to use a Pause On Alarm, Caution, or Error. When you select the OK for the resulting dialog box, the CSS500~ALARM\_OFF function is called.

---

You can create your own function by the same name. CSS500 will not overwrite the functions if they already exist in the VM700A. The function you create can perform any type of action. This can be printing messages on the printer or even dialing a personal pager by way of a modem attached to one of the VM700A Serial Ports. See the VM700A manuals for more information on how to write your own functions.

---

**NOTE.** A VM700A measurement result does not need to be the cause of an Execute VM700A Function. “Non-standard” measurement results from any instrument can cause a call to the VM700A function.

---

Report out RS-232 sends a Violation Report out the Com Port (set with Connections, from the Preferences menu). Based on the conditions selected, the following information is sent: Site Name, Measurement Column Heading, Channel Number/Tag/Program, Condition Type (alarm, caution, or error), and Date/Time. This information is tab delimited and packetized ASCII text. Each Violation Report is one packet and each packet consists of:

- A one byte Byte Count that gives the number of bytes in the Violation Report (this includes the checksum)
- The Violation Report in ASCII text
- A one byte checksum (simple addition, including the Byte Count)

An additional reporting option is to broadcast a message to all active Windows applications that have registered to intercept this message. This function allows you to perform additional processing when an alarm occurs. To receive these messages, your Windows application must execute the following line of code:

```
nAlarmMsg = RegisterWindowMessage("WM_POST_ALARM_MESSAGE");
```

The variable `nAlarmMsg` represents the unique Windows message number. To intercept it, simply test for `nAlarmMsg` in the main messaging loop. The severity of the nonstandard condition is indicated by `msg.lParam` (Action = 1, Alarm = 2, and Error = 3). For example:

```
MSG msg;
while (getMessage(&msg, NULL, 0, 0))
{
    if (msg.message == nAlarmMsg)
    {
        if(msg.lParam == 1)
            MessageBox(NULL, "Got Caution Message!", NULL, MB_OK);
        else if (msg.lParam == 2)
            MessageBox(NULL, "Got Alarm Message!", NULL, MB_OK);
        else if (msg.lParam == 3)
            MessageBox(NULL, "Got Error Message!", NULL, MB_OK);
    }
}
```

---

**NOTE.** This option is not “set” anywhere. It is automatically available whenever an alarm, caution, or error result is encountered.

---

### Measurement Sequence

The Measurement Sequence menu (see Figure 3–36) allows you to program a set of measurements to execute every time the Meas Seq command button (see page 3–86) or Measurement Sequence command (under the Measure menu, see page 3–45) is chosen. This allows a regularly used set of measurements to be invoked with a single mouse click instead of running each individual measurement one at a time.

**Measurement Sequence**

**Auto Selection**

**Carrier Survey**

	Vis Car Lev	Vis Car Frq	Aur Car Lev	Aur Car Frq	2nd Aur Lev	2nd Aur Frq	Avg Pwr	C / N	D / U	C S O	C T B	X Mod	A C L	I C R	H U M	FCC BB	Mod Dep	Aur Dev	S / N	Wfm Dis
2	X	X	X	X	X	X														
3	X	X	X	X	X	X		X		X	X	X		X	X					
4	X	X	X	X	X	X														
5	X	X	X	X	X	X		X		X	X	X		X	X					
6	X	X	X	X	X	X														
95	X	X	X	X	X	X		X		X	X	X		X	X					
96	X	X	X	X	X	X														
97	X	X	X	X	X	X		X		X	X	X		X	X					
98	X	X	X	X	X	X														
99	X	X	X	X	X	X														
14	X	X	X	X	X	X														
15	X	X	X	X	X	X		X		X	X	X		X	X					
16	X	X	X	X	X	X														
17	X	X	X	X	X	X														
18	X	X	X	X	X	X														
19	X	X	X	X	X	X		X		X	X	X		X	X					
20	X	X	X	X	X	X														
21	X	X	X	X	X	X														

Figure 3-36: Measurement Sequence dialog box

An “X” in a cell indicates that the channel and measurement are part of the Measurement Sequence. Select as many or few cells as needed to define a Measurement Sequence. When all of the desired cells are selected, choose the OK command button; the Measurement Sequence immediately loads and is stored under the Meas Seq command button.

To speed up the process for likely groups of measurements, there are four predefined “Auto Selection” Measurement Sequences. They are: FCC Pre-and Post Converter Measurements, FCC Headend Measurements, and 24 Hour Measurements. If the country is not United States, then only the 24 Hour Test automatic selection button is available. The Country is selected from the Windows Control Panel, International icon. Table 3-6 give a list of measurements included in the Auto Selections. These measurements are executed on the channels selected by the user. Whenever one of these Auto-Selection command buttons is chosen, it loads the measurements immediately into the Measurement Sequence. Additional measurements are then added or deleted as desired by the user to complete a Measurement Sequence.

Table 3-6: Auto Configure buttons

Channels	Auto Selection Button			
	FCC Pre-Converter	FCC Post-Converter	FCC Headend	24 Hour Test <sup>1</sup>
All Channels	Carrier Levels and Frequencies	Carrier Levels and Frequencies	Carrier Levels and Frequencies	Carrier Levels and Frequencies
Selected Channels	ICR or Multiburst	Carrier to Noise Ratio	FCC Baseband	
Selected Channels		CSO		
Selected Channels		CTB		
Selected Channels		Cross Modulation		
Selected Channels		Hum		

<sup>1</sup> The 24 Hour Test automatically includes 4 repetitions at 6-hour intervals.

There are other options on the Measurement Sequence menu. They include: Carrier Survey, Edit Time Parameters, Generate 2714/2715 UDP, and Clear Sequence.

If you want to make the Carrier Levels and Frequencies measurements (Visual Carrier Levels, Visual Carrier Frequency, Aural Carrier Level, Aural Frequency Offset, Second Aural Carrier, and Second Aural Frequency) and Average Power measurements on all channels in the Measurement Sequence, then you can do a Carrier Survey instead of a series of individual measurements. (A carrier survey makes all of the Aural, Visual Carrier Amplitude, Frequency, and Average Power measurements first, and then the rest of the selected measurements.) The advantages and drawbacks of selecting the Carrier Survey are as follows:

Advantages:

- Faster measurement execution
- Smaller UDP size (allows for more measurements to be loaded before exceeding the UDP size limit)

Disadvantages:

- The Pause For New Channel preference will not pause for new channels within the survey
- All measurement results are tagged with the same date and time

Whether you select individual measurements or the survey, the measurements will still be made in the mode specified in the Measurement Setups dialog box.

The Edit Time Parameters dialog box tells the sequence when to start, and how many times to run. (See Figure 3–37.)

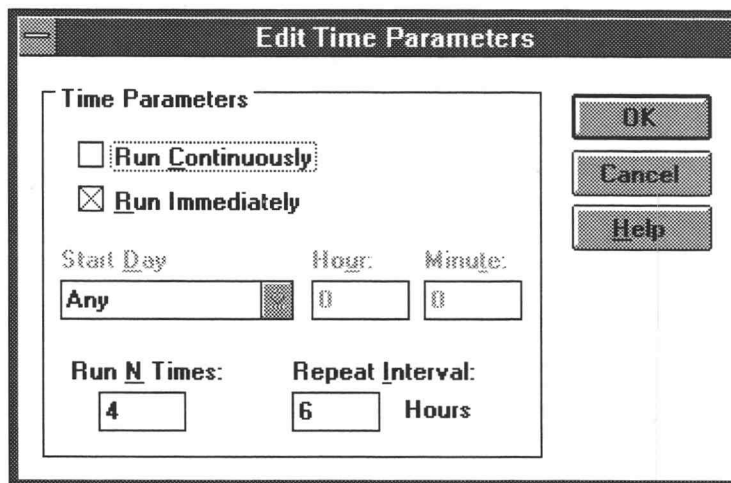

Figure 3–37: Edit Time Parameters dialog box

Run Continuously runs the Measurement Sequence in an infinite loop. It runs through the entire Measurement Sequence and then starts over again until you choose the Cancel command button.

Run Immediately starts the Measurement Sequence whenever the Meas Seq command button (or equivalent) is chosen.

If the Run Immediately check box is not selected, then the Start Day needs to be selected from the list box. Your options are Any or a particular day of the week. Any means “today.” If a specific day of the week is selected, then the Measurement Sequence will not start until the computer’s internal clock reaches that day. Enter the starting Hour and Minute (in 24-hour time) that you want it to start in the Hour and Minute text box.

Please note that the Start Time is only defined by the internal clock for the PC running CSS500, if the Measurement Sequence is run directly from CSS500. If a UDP is generated and the Measurement Sequence is run from a remote location, then the 271X’s internal clock is used as the timing reference. (All time/date stamps for a measurement are from the 271X’s internal clock.)

Use the Run N Times text box, if you want the Measurement Sequence not to run continuously. You enter the number of times in the Run N Times text box and the Repeat Interval in its text box. If you only want the sequence to run once, enter “1” in the Run N Times box and “0” in the Repeat Interval text box.

If you are running a Measurement Sequence several times and the Measurement Sequence is longer than the Repeat Interval, the Measurement Sequence will simply start the next run as soon as the previous one completes.

The Repeat Interval must be an integer number of hours. The Repeat Interval counts from the Measurement Sequence start time.

**Create 2714/2715 UDP.** If a Measurement Sequence is being defined for a 271X to use at a remote location, then you use the Create 2714/2715 UDP (User Defined Program) command button. This command button converts the CSS500 Measurement Sequence into a UDP and immediately loads it into the 271X. The instrument can then use the UDP to make measurements later at a remote location. You can load the results back into the CSS500 application using the Get Stored Results from 2714/2715 command (located in the Measure menu, see page 3-46).

Up to nine UDPs can be stored in each 271X. If the 271X will not load a UDP, it may already have nine UDPs. CSS500 allows up to 28 characters with no commas or semicolons for the UDP title (see Figure 3-38).

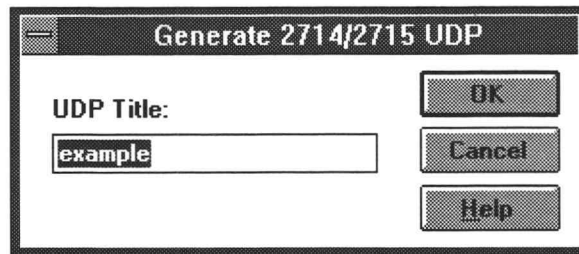

**Figure 3-38: Generate 2714/2715 UDP dialog box**

When running a UDP, the preferred amplitude units may not be reflected on the 271X display. This does not make a difference, since the units convert to the desired value when the results load into the CSS500 worksheet.

Be careful when defining a Measurement Sequence for a UDP. Remember that all header and preference information must be correct before the UDP is loaded into the 271X. The information sent includes: Channel Table, Measurement Execution Preferences (Pause on New Channel and Prompt for Signal Connection), Start Day and Time, Repeat Interval, Repeat Count (Run N Times), Visual Carrier Level Units, and Test ID (Operator Field in the 271X –not editable at the 271X). See Table 3-7 for a complete list of what is loaded into the 271X when a UDP is created.



**Table 3–7: Information loaded into the 271X during the creation of an UDP**

Parameter	Where Edited
Title	User entered at the Generate 2714/2715 UDP prompt
Run N Times	The Edit Time Parameters, from the Measurement Sequence dialog box (Configure menu)
Repeat Interval	
Start Day	
Start Hour	
Start Time	
Prompt for Signal Connection	From Preferences in the Configure menu
Pause on New Channel	From Preferences in the Configure menu
Channel Table	From the Worksheet Info dialog box (Configure menu)
Test ID	From Test ID (Configure menu)
Reference Level Units	From Preferences (Configure menu)
Measurement Setups <sup>1</sup> (for the individual channels)	From the Measurement Setups dialog box (Configure menu)
Power Line Frequency	From the Measurement Setups dialog box (Configure menu)
External Attenuation/Amplification	From the Measurement Setups dialog box (Configure menu)
Preamp	From the Measurement Setups dialog box (Configure menu)
Measurements on Channels <sup>2</sup>	From the Measurement Sequence (Configure menu)

<sup>1</sup> If the Gated option is selected for one or more measurements and you are trying to send the UDP to a 2714, you are given a warning that Gated is not supported and allowed to continue with Auto mode.

<sup>2</sup> If a digital measurement (Average Power, Desirable to Undesirable, or Adjacent Channel Leakage) is selected for one or more channels and you are trying to send the UDP to a 2714 or 2715 that does not support digital measurements (2715 if firmware version 09-30-94 or earlier) a warning is displayed that digital measurements are not supported and will be skipped.

If a baseband video test is selected and you are trying to create a 271X UDP, you are given a warning that baseband video tests (FCC Baseband, Signal to Noise, Waveform Distortion, Multiburst, ICPM and Audio) are not supported by the 2714 or 2715, and the tests will be skipped.

If any of the conditions described in notes 1 or 2 were encountered, a summary of the warnings is displayed. You will be given a chance to continue generating the UDP, with the problems handled as indicated, by pressing OK, or you can quit generating the UDP by pressing CANCEL.

UDPs are not necessarily fully automated. Many measurements require operator input to collect results. Table 3–8 lists the measurements that may require operator input, the type of input required, and the circumstances that cause the operator input to be required.

**Table 3–8: Measurements that require operator input**

Measurements	Operator Input Required			
	Turn Carrier On/Off	Turn Modulation On/Off	Turn Scrambling On/Off	Turn On/Off Test Signal
Carrier to Noise	1		6	
Desirable to Undesirable	2			
CSO	1		6	
CTB	1			
Cross Modulation		2		
ICR			6	5
Hum/LFD			3	
Modulation Depth			3 (RF only)	
Aural Deviation				
Audio				7
ALL			4	
Explanations	1. Auto with Pause or Single Sweep only. (Change via Measurement Setups from the Configure menu.) 2. Always prompts. 3. Only prompts if the channel is flagged as scrambled in the Channel Table. 4. Always prompts you to turn off scrambling as soon as it reaches a measurement that requires the scrambling turned off. Will also prompt you to turn the scrambling back on after making all measurements for that channel. 5. Only if this measurement is not made using Gated. 6. Only if this measurement is made using Gated and the channel is flagged as scrambled in the channel table. 7. Audio measurements may require that the ASG100 Test Sequence be started.			

To generate a user defined program (UDP) that will run unattended, select the measurement modes shown in Table 3–9. Desired to Undesired and Cross Modulation always require user intervention; they cannot be run unattended in a UDP.

**Table 3–9: Modes for unattended UDPs**

Measurement	Mode
Carrier Levels and Frequencies	Any mode
Average Power	Accurate Amplitude
Carrier to Noise	Auto or Gated <sup>1</sup>
CSO <sup>2</sup>	Auto <sup>3</sup> or Gated <sup>1</sup>
CTB	Auto <sup>3</sup>
Adjacent Channel Leakage	Any mode
In-Channel Response	Gated <sup>4</sup>
Hum/LFD	Any mode <sup>4</sup>
Modulation Depth	Any mode <sup>4</sup>
Aural Deviation	Any mode

- <sup>1</sup> For Gated mode to work without user intervention in Carrier to Noise and CSO measurements, the channel must not be scrambled. If the channel is scrambled, Carrier to Noise and CSO must be run in Auto mode to avoid user intervention.
- <sup>2</sup> On digital channels, CSO and CTB always run in Auto with Pause mode. This mode requires user intervention. To avoid user intervention, make sure CSO and CTB are not selected for digital channels.
- <sup>3</sup> Measure Beat in an empty adjacent channel.
- <sup>4</sup> If the channel is scrambled, ICR, Hum/LFD, and Modulation Depth cannot be run without user intervention.

The selected Channel Table must exist in the instrument when the UDP is run or an error message will occur. The Channel Table is not loaded into the instrument by the UDP. Use the Channel Table Editor to load the Channel Table into the instrument. (See Appendix C.)

The Site is not part of the UDP and it is the operator's responsibility to correctly load it into the instrument before the UDP is run. This way the same UDP can be run at several Sites.

**Measurement Sequences in Non-US Countries.** If you are using CSS500 in a country other than the US, your Measurement Sequence dialog box will look different. See Figure 3–39. (The country is defined in the Windows Control Panel using the International icon. The first line in the International dialog box is the Country.) The differences are due to FCC (a US regulatory body) requirements. If you want to use the FCC Auto Selection buttons, change your country from the Windows Control Panel to United States, and restart the CSS500 application.

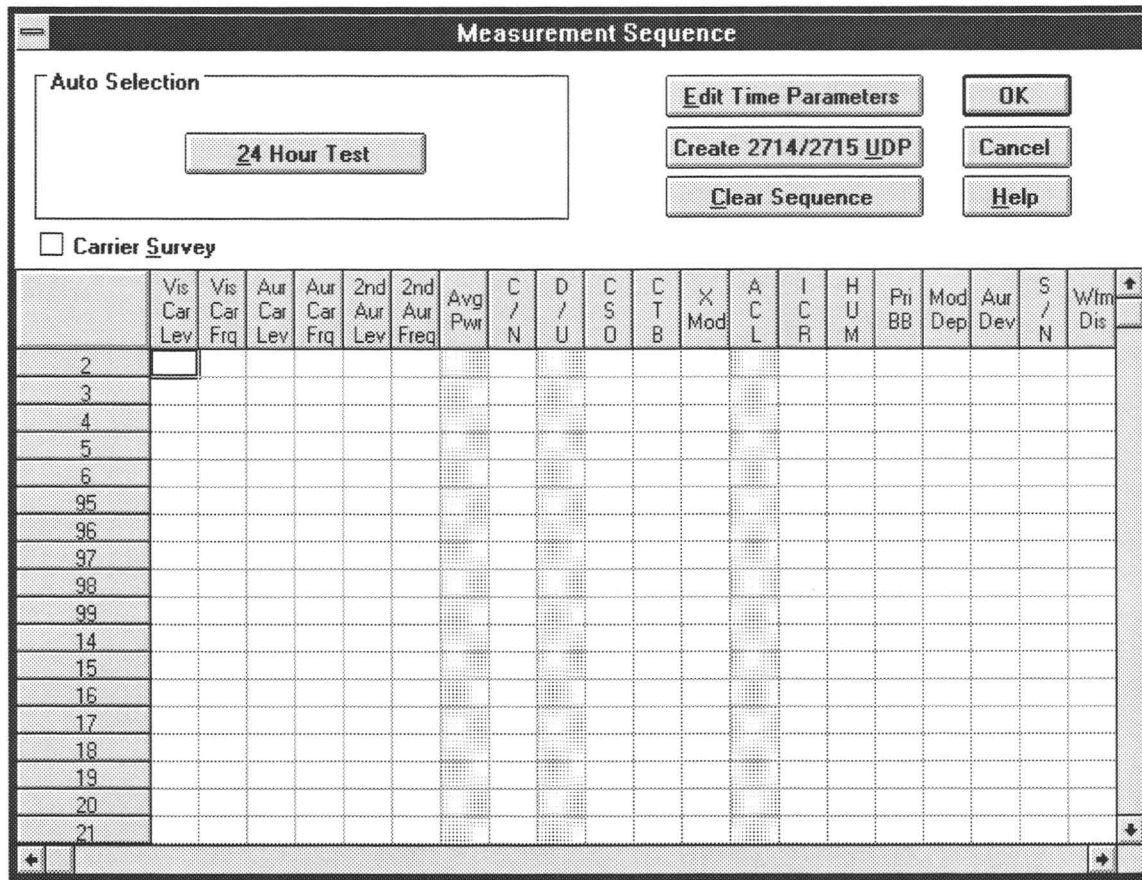

Figure 3-39: A non-US Measurement Sequence dialog box

**Measurement Limits**

The Measurements Limits file defines the alarm and caution levels for the measurement results. There is a default Limits file that comes with the CSS500 application, but you can edit the file to conform to your needs. Each channel can have a different Limits file assigned (for example, one for premium channel, one for local, and one for cable access) or one Limits file for all the channels. Attach a Limits file to a channel using the <-Select Limits File command button. See Figure 3-40.

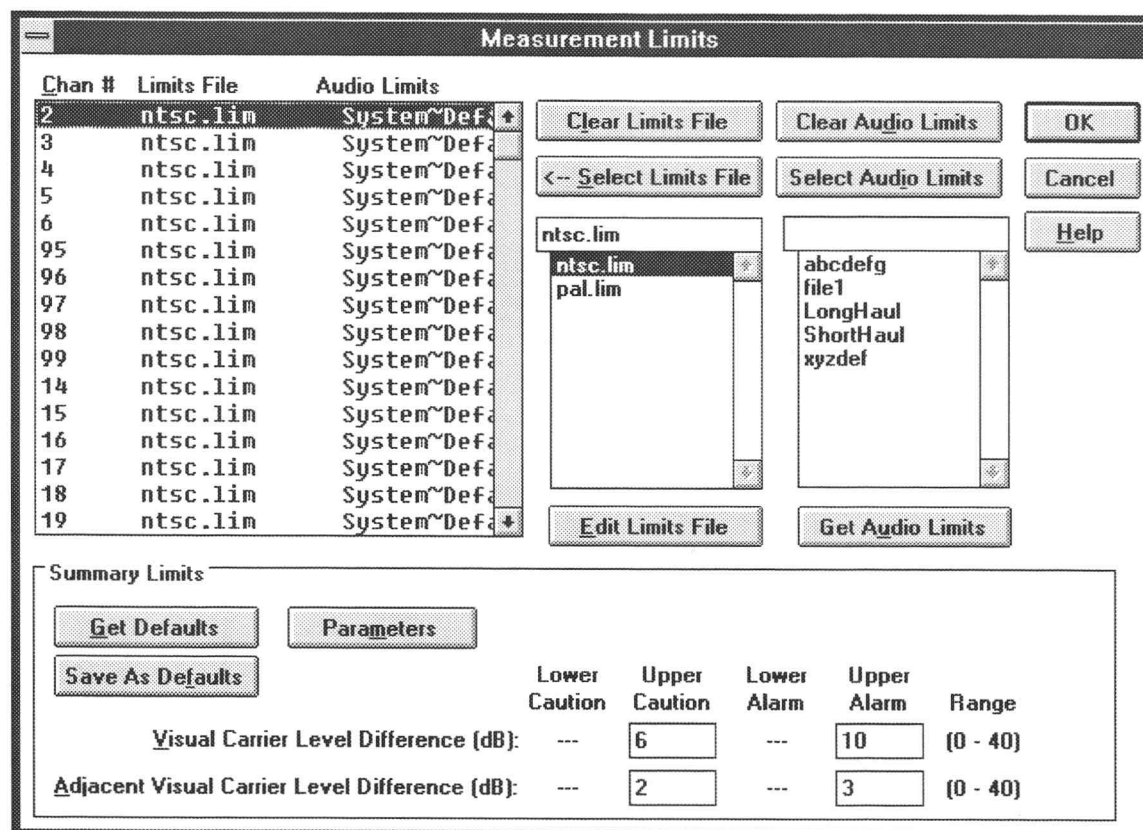

Figure 3-40: The Measurement Limits dialog box

**Clear Limits File.** The Clear Limits File command button removes the limits file from selected channels. CSS500 can still make measurements and save results without a Limits file, but there will be no Caution, Alarm, or Passing flags in the results. As soon as a Limits file is attached to a channel all of the measurement results made for that channel are flagged according to that Limits file.

**<--Select Limits File.** This command button attaches the selected Limits File in the Limits file combo box to the selected channel. All results for that channel are flagged according to the new Limits file (including all history).

**Edit Limits File.** This command button allows you to edit the selected Limits file from the Limits File list box shown in Figure 3-41.



**CAUTION.** Any changes made by editing a Limits file affect all worksheets using that Limits file, not just the current worksheet.

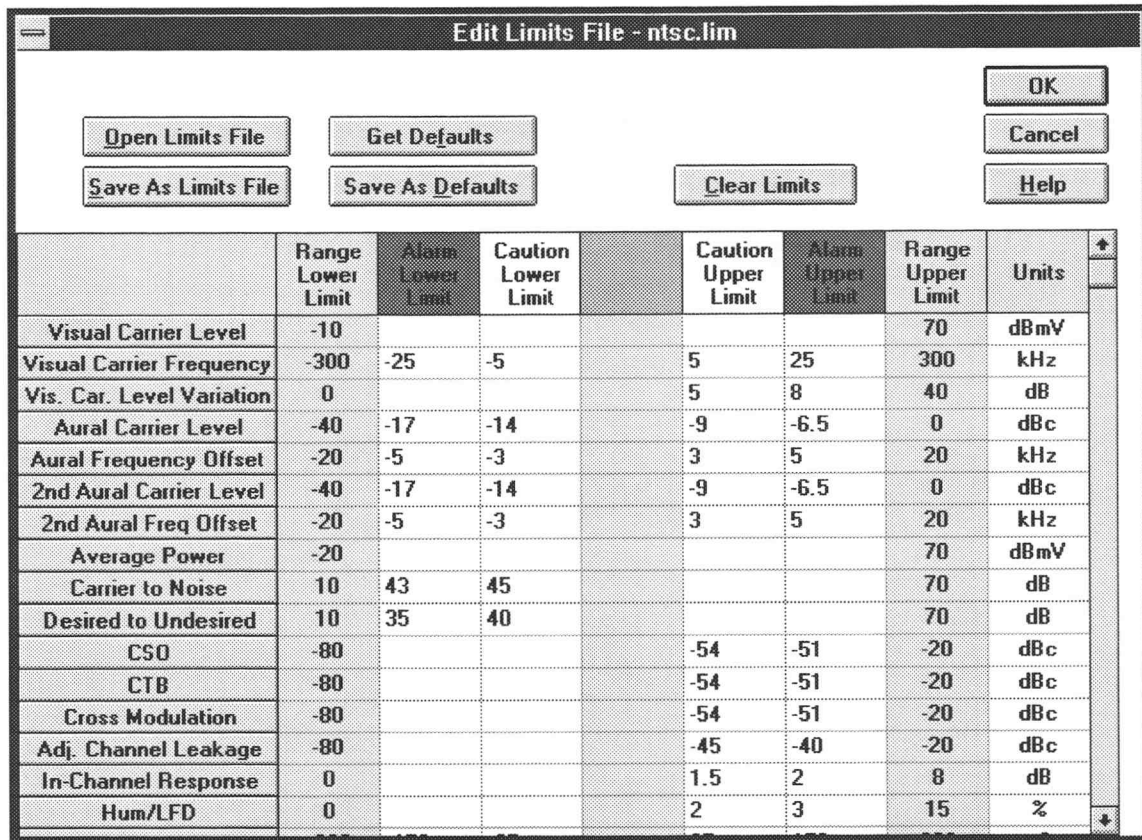

Figure 3-41: The Edit Limits File dialog box

**NOTE.** The Visual Carrier Frequency, Aural Frequency Offset, and Second Aural Frequency Offset are specified in deviation from nominal.

If you want to edit a Limits file, start by renaming a copy of one of the provided Limits files and edit that file rather than one of the provided files. To rename the file select the Save As Limits File command button, enter a new name for the Limits file, and then select the OK button. This way, the original file will remain uncorrupted (in case any errors occur during editing). The files provided with CSS500 are read-only. If you choose to edit them, you must change the read-only attribute first or you cannot save any changes.

The Limits file must be in the Limits sub-directory under the directory that contains the CSS500.EXE file. The Limits file should end in “.lim” to help simplify your file management.

You can't edit the Range columns or the Units (they are shown for user information only), but the Limits columns are editable. Figure 3-42 shows how the Upper and Lower Limits work to flag measurement results. Those four

columns are editable, but they are limited by the Range Limits. If you attempt to enter a value outside those defined by the Range limits then you will get an error message, that cell will be highlighted, and it will expect a correct value to be entered.

Aural carrier frequency

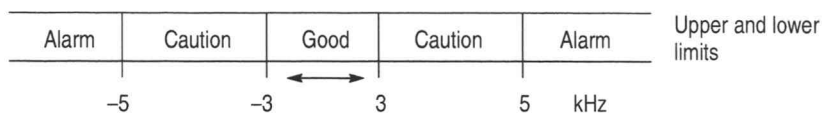

Carrier to noise

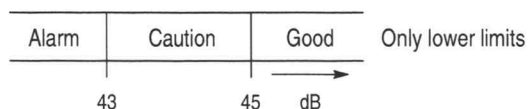

ICR

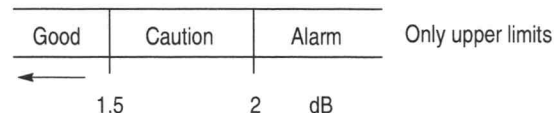

**Figure 3–42: How the upper and lower limits work**

The command buttons in the Edit Limits File dialog box are:

- **Open Limits File.** The Open Limits File command button allows you to select a different Limits File to edit. The name of the Limits file that you are currently editing is in the Title Bar for the Edit Limits dialog box.
- **Save As Limits File.** Save As Limits File command button saves any changes made to the current Limits file (the one whose name is in the Title Bar). Don't forget that any changes made to this Limits file are reflected in every worksheet that uses that Limits file.
- **Get Defaults.** Get Defaults places all of the default values into the Edit Limits dialog box.
- **Save As Defaults (See Figure 3–43).** This command button takes all of the current values in the Limits file and saves them to a new Limits file which is then used as the default Limits file. The default Limits file values are loaded into the current Limits file using the Get Defaults command button. It also is used as the Limits file for all channels whenever a new worksheet is defined or you start making measurements without defining any worksheet. This new Limits file can have the same name as the file you were editing but it would help your file management to call it, "Default" or something similar, so that you can remember what you are using as the default Limits file.

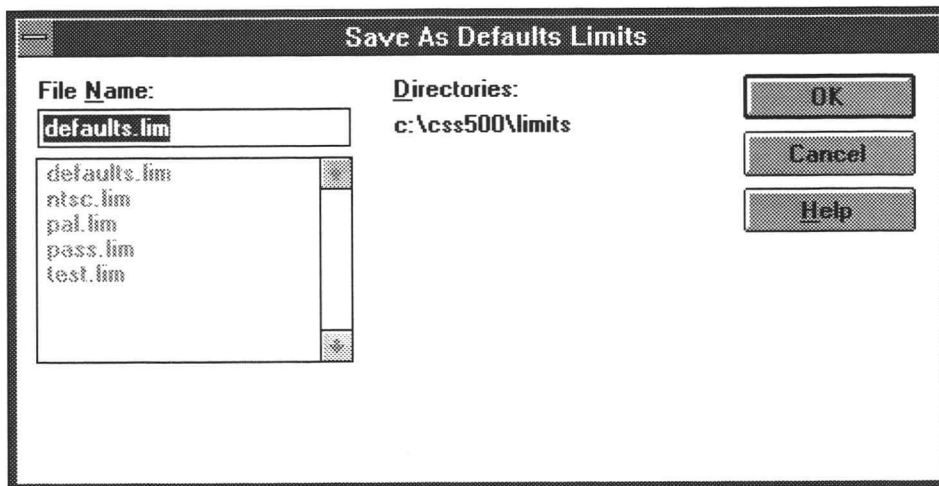

**Figure 3–43: The Save As Defaults dialog box**

- **Clear Limits.** This command button clears all of the limits from all of the measurements. If this is done by accident, you can recover by choosing the Cancel Command button.
- **Audio Limits.** When you execute an audio measurement, the Audio Limits file specified for the channel is activated in the VM700A. If it is not present, an error message is displayed and the measurement terminated. If no audio limit was assigned to the channel, then the default VM700A Audio Limits file is used, SYSTEM~DEFAULT. If you want to change the default Audio Limits file, you must make the change in the CSS500.INI file. (See *The CSS500.INI File* on page E–6 for how to make this change.)

Limits for audio measurements are not stored in the CSS500 Limits file, since many are graphical in nature and cannot be represented by individual values. There are two main consequences. First, changing the Audio Limits file (this can only be done from the VM700A) has no effect on previous measurement results flagging (unlike the rest of the Limits files which change all the measurement results that use that limit file). Second, the measurement limits have those numbers available at all times. The audio limits only have numbers available when a measurement fails.



**NOTE.** Audio limits are different from video limits in several important ways:

- Audio limits come from the VM700A.
- You cannot edit the audio limits with CSS500. That must be done at the VM700A.
- Audio limits stay with measurement results forever. Even if you change the Limits file associated with a particular channel older results do not change their alarm, caution, or error state.

**Clear Audio Limits.** Remove the Audio Limits file from the selected Channel(s).

**Select Audio Limits.** Sets the current channel to the currently selected audio limits.

**Get Audio Limits.** Reads the list of available audio limits from the connected VM700A and places them in the audio limits list box.

**Summary Limits.** The Summary Limits at the bottom of the Limits window are global parameters in that they apply to all channels (see Figure 3–44).

Summary Limits						
<input type="button" value="Get Defaults"/>		<input type="button" value="Parameters"/>				
<input type="button" value="Save As Defaults"/>						
		Lower Caution	Upper Caution	Lower Alarm	Upper Alarm	Range
Visual Carrier Level Difference (dB):	---	6	---	10	---	(0 - 40)
Adjacent Visual Carrier Level Difference (dB):	---	2	---	3	---	(0 - 40)

Figure 3–44: Summary Limits (part of the Measurement Limits dialog box)

Visual Carrier Level Differences defines the range that the Visual carrier can vary across all channels. Adjacent Visual Carrier Level Difference is the amount of variation in amplitude between two channels that are next to each other in frequency. The Adjacent results may be misleading if a View Filter is on because channels next to each other in the worksheet are not necessarily next to each other in frequency.

---

**NOTE.** *If a View Filter is on, some measurement results can be misleading. Take note of the View Filter Status when interpreting results.*

---

These parameters are not visible on the worksheet; rather they are part of the Status Report, Results Detail, and Measurement Summary.

The Get Defaults command button loads the default values into the Summary limits. The Save As Defaults button sets the current values as the defaults.

Choose the Parameters command button to set the window for adjacent channels. This dialog box (see Figure 3–45) defines what constitutes an adjacent channel. Any “adjacent” channels that are outside of this frequency window are not included in the calculations. Select what is required for your system and then choose OK.

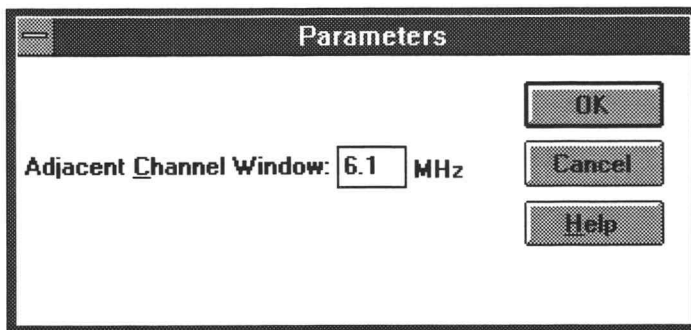

**Figure 3–45: The Parameters dialog box**

### Measurement Setups

There are many different ways that test equipment can be set up. The configuration tells CSS500 how your system is set up to retrieve the correct results. Find this item under the Configure menu, Measurement Setups. There are setups that affect all channels and some that are channel specific. The Measurement Setups dialog box is shown in Figure 3–46.

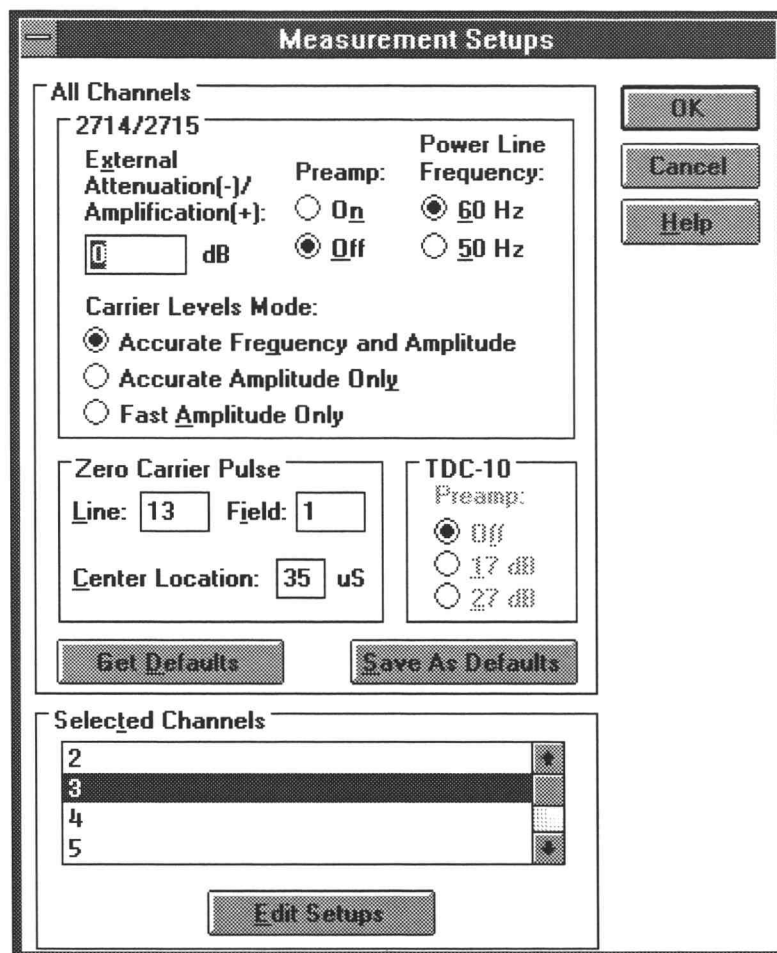

Figure 3-46: The Measurement Setups dialog box

**All Channels Group.** The All Channels group allows you to customize measurements. The All Channels group categories include Get Defaults, Save As Defaults, Zero Carrier Pulse, TDC-10 and 2714/2715.

**Get Defaults.** This command button loads all of the previously saved default values into the All Channels group text boxes and option buttons.

**Save As Defaults.** This command button saves all of the current text box and option button settings as the default values. The default values are automatically loaded whenever a new worksheet is created. They are also available through the Get Defaults command button.

- **2714/2715 Sub-group.** This group allows you to set up the software to match your equipment setup.

External Attenuation/Amplification. Enter the necessary attenuation or amplification (in dB) needed to compensate for losses or gains in your system in this text box. For example, if a measurement is being made at a 20 dB down test point, enter -20 in the text box.

Power Line Frequency. Either 50 or 60 Hz.

Preamp. Select the On or Off option button to match your equipment setup. The Preamp is generally “on” in low-level signal conditions to improve the resolution of the measurements. Set the Preamp according to the specifications in the 2714 manual. The 2715 automatically uses the optimum preamp setting and then resets it back to the value selected to this option button.

Carrier Level Mode. This setup specifies the mode used when making carrier level measurements. The options are: Accurate Frequency and Amplitude, Accurate Amplitude Only, and Fast Amplitude Only. The selection applies to individual carrier level measurements as well as surveys.

---

**NOTE.** *It is recommended that you use Accurate Frequency and Amplitude for any FCC measurements.*

---

- Zero Carrier Pulse Sub-group. This group allows you to set the parameters related to the Zero Carrier Pulse.

Zero Carrier Pulse. The Zero Carrier Pulse is available from both fields on lines 10 through 25. The VM700A uses this as a timing reference. Make sure that the reference set here is the same as the reference set by internal jumpers in the 1450A or the TV1350.

- TDC-10 Sub-group. This group allows you to set the amplification used by the TDC-10.

---

**NOTE.** *The TDC-10 selection is not available if the TV1350 or EMPF Demodulator is selected.*

---

Preamp. The Preamp allows improved sensitivity when measuring low-level signals. Select the RF preamplification according to the specifications in the TDC-10 manual.

**Selected Channels Group.** The Selected Channels Group allows you to continue customizing measurements down to the individual channel. The categories found under Selected Channels are: Carrier to Noise, VM700A VITS, VM700A Measurements, Modulation Depth, CSO, CTB, and In-Channel Response.

Edit the individual channels by choosing the Edit Setups command button. The dialog box is shown in Figure 3-47.

**Edit Setups for Channel 2 55.25 MHz**

<p><b>Carrier to Noise</b></p> <p><input checked="" type="radio"/> <b>Auto</b></p> <p><input type="radio"/> <b>Auto with Pause</b></p> <p><input type="radio"/> <b>Gated</b></p> <p>Noise Bandwidth: <input type="text" value="4"/> MHz</p>	<p><b>VM700A VITS</b></p> <table style="width: 100%; border-collapse: collapse;"> <thead> <tr> <th></th> <th style="text-align: center;">Line</th> <th style="text-align: center;">Field</th> </tr> </thead> <tbody> <tr> <td><b>Multiburst:</b></td> <td style="text-align: center;"><input type="text" value="17"/></td> <td style="text-align: center;"><input type="text" value="1"/></td> </tr> <tr> <td><b>Composite:</b></td> <td style="text-align: center;"><input type="text" value="18"/></td> <td style="text-align: center;"><input type="text" value="1"/></td> </tr> <tr> <td><b>Combination:</b></td> <td style="text-align: center;"><input type="text" value="17"/></td> <td style="text-align: center;"><input type="text" value="2"/></td> </tr> <tr> <td><b>Noise (Quiet):</b></td> <td style="text-align: center;"><input type="text" value="12"/></td> <td style="text-align: center;"><input type="text" value="1"/></td> </tr> <tr> <td><b>Sin(x)/x:</b></td> <td style="text-align: center;"><input type="text" value="17"/></td> <td style="text-align: center;"><input type="text" value="2"/></td> </tr> </tbody> </table>		Line	Field	<b>Multiburst:</b>	<input type="text" value="17"/>	<input type="text" value="1"/>	<b>Composite:</b>	<input type="text" value="18"/>	<input type="text" value="1"/>	<b>Combination:</b>	<input type="text" value="17"/>	<input type="text" value="2"/>	<b>Noise (Quiet):</b>	<input type="text" value="12"/>	<input type="text" value="1"/>	<b>Sin(x)/x:</b>	<input type="text" value="17"/>	<input type="text" value="2"/>	<p><b>ACL</b></p> <p><input type="radio"/> <b>Upper</b></p> <p><input type="radio"/> <b>Lower</b></p> <p><input checked="" type="radio"/> <b>Both</b></p> <p style="text-align: right;"> <input type="button" value="OK"/>  <input type="button" value="Cancel"/>  <input type="button" value="Help"/> </p> <p style="text-align: center;"> <input type="button" value="Get Defaults"/>  <input type="button" value="Save As Defaults"/>  <input type="button" value="Copy to All Channels"/> </p>
	Line	Field																		
<b>Multiburst:</b>	<input type="text" value="17"/>	<input type="text" value="1"/>																		
<b>Composite:</b>	<input type="text" value="18"/>	<input type="text" value="1"/>																		
<b>Combination:</b>	<input type="text" value="17"/>	<input type="text" value="2"/>																		
<b>Noise (Quiet):</b>	<input type="text" value="12"/>	<input type="text" value="1"/>																		
<b>Sin(x)/x:</b>	<input type="text" value="17"/>	<input type="text" value="2"/>																		
<p><b>Mod. Depth</b></p> <p><input type="radio"/> <b>Baseband</b></p> <p><input checked="" type="radio"/> <b>RF</b></p>	<p><b>VM700A Msmts.</b></p> <p><input checked="" type="radio"/> <b>Source A,C</b></p> <p><input type="radio"/> <b>Source B</b></p>																			
<p><b>CSO</b></p> <p><input checked="" type="radio"/> <b>Auto</b></p> <p><input type="radio"/> <b>Auto with Pause</b></p> <p><input type="radio"/> <b>Single Sweep</b></p> <p><input type="radio"/> <b>Gated</b></p> <p><b>Test Locations (MHz):</b></p> <p><input type="text" value="-1.25"/> (Rel)</p> <p><input type="text" value="-0.75"/> (Rel)</p> <p><input type="text" value="0.75"/> (Rel)</p> <p><input type="text" value="1.25"/> (Rel)</p> <p><input type="text"/> (Rel)</p>	<p><b>CTB</b></p> <p><input checked="" type="radio"/> <b>Auto</b></p> <p><input type="radio"/> <b>Auto with Pause</b></p> <p><input type="radio"/> <b>Single Sweep</b></p> <p><b>Test Locations (MHz):</b></p> <p><input type="text" value="0"/> <input checked="" type="radio"/> Rel <input type="radio"/> Abs</p> <p><input type="text"/> <input checked="" type="radio"/> Rel <input type="radio"/> Abs</p> <p><input type="text"/> <input checked="" type="radio"/> Rel <input type="radio"/> Abs</p> <p><input type="text"/> <input checked="" type="radio"/> Rel <input type="radio"/> Abs</p> <p><input type="text"/> <input checked="" type="radio"/> Rel <input type="radio"/> Abs</p>	<p><b>In-Channel Response</b></p> <p><input type="radio"/> <b>Baseband (Sin(x)/x)</b></p> <p><input checked="" type="radio"/> <b>RF</b> <input type="checkbox"/> <b>Gated</b></p> <p><b>Test Locations (MHz):</b></p> <p><input type="text" value="-0.5"/> (Rel)</p> <p><input type="text" value="0.5"/> (Rel)</p> <p><input type="text" value="1.25"/> (Rel)</p> <p><input type="text" value="2"/> (Rel)</p> <p><input type="text" value="3"/> (Rel)</p> <p><input type="text" value="3.75"/> (Rel)</p>																		

**Figure 3-47: The Edit Setups dialog box**

**Carrier to Noise Group.** Select the Auto, Auto with Pause, or Gated option button. Auto with Pause requires that the carrier be turned off in order to make the measurement. The measurement will stop and prompt you to turn off the carrier and wait for you to respond that the carrier is off before it will continue making measurements. Auto makes the measurement without taking the channel out of service or requiring any operator interface. Gated makes the measurement on a non-modulated line, therefore there is no requirement to turn the carrier off or take the channel out of service. Gated is only available for the 2715.

Enter the bandwidth for the noise calculation in the Noise Bandwidth text box.

**Modulation Depth Group.** Select either Baseband or RF option buttons for how to make the Modulation Depth measurement. If Baseband, the VM700A makes the measurement. If RF, then the 271X makes the measurement.

**VM 700A Measurements Group.** Select either Source A, C or Source B as the rear panel connection where the VM700A should look for the input signal.

---

**NOTE.** *ICPM measurements cannot be made if Source B is selected.*

---

ACL Group. Measures the power in the channels adjacent to the channel under test. This is a headend test with the 2715 connected to the test port of the modulator. Select Upper to measure the power in the upper adjacent channel only, Lower to measure the lower adjacent channel only, or Both to measure both the upper and lower channels.

In-Channel Response Group. Selects how you want the In-Channel Response (ICR) measurement executed.

Select either the Baseband (Sin(x)/x) or RF option button. The baseband option uses the VM700A while the RF uses the 271X to make the ICR measurement. Sometimes, you only have one or the other piece of equipment available and this measurement can be made either way.

If you select the RF option you can also make that measurement Gated. Gated is called “in service” on the 2715 instruments. This allows measurements to be made on-line with no modulation.

Whichever option button you select, enter the relative frequencies where you want the measurement calculated (up to six locations for RF and seven locations for Baseband) in the Test Locations text boxes.

CSO Group. Select the way you want the CSO measurement performed by selecting Auto, Auto with Pause, Single Sweep, or Gated option Buttons. For digital channels, only Auto with Pause is available. Gated is called “in service” on the 271X instruments. This allows measurements to be made on-line with no modulation.

Enter up to five relative test locations for the CSO measurement in the Test Locations text boxes. Be sure to take into consideration the way that the 271X handles CSO and CTB measurements if you are doing a measurement setup for a UDP.

See the following discussion on *Distinguishing 2714 CTB and CSO Measurement Results* in the UDP.

CTB Group. Select the way you want the CTB measurement made using the Auto, Auto with Pause, or Single Sweep option buttons. For digital channels, only Auto with Pause is available.

Enter up to five test locations for the CTB measurement in the Test Locations text boxes. Select either the Rel (relative) or Abs (absolute) option buttons for each test location. Again, be sure to take into consideration the way that the 271X handles CSO and CTB measurements if you are doing a measurement setup for a UDP. See the following discussion on *Distinguishing 2714 CTB and CSO Measurement Results* in the UDP.

Distinguishing 2714 CTB and CSO Measurement Results. The following is a description of how the CSS500 splits the generic 2714 distortion results into separate CTB and CSO results.

---

**NOTE.** *This discussion applies only to the Get Stored Results from the 2714/2715 function, from the Measure menu. Early versions of the 2714 firmware (06.05.92 and 01.05.93) had CTB and CSO combined into a single test called CTB/CSO. CSS500 keeps CTB and CSO test results separate. When a user gets stored results from a 2714 with early firmware, CSS500 must make a determination as to whether each CTB/CSO result from the 2714 should be treated as a CTB result or a CSO result. The paragraphs below describe how CSS500 makes this determination, based on the value of the test frequency and whether the frequency was specified as relative or absolute.*

---

Begin with a default CTB and CSO Measurement Setup of:

CSO:  $\pm 1.25\text{MHz}$  (Rel),  $\pm 0.75\text{MHz}$  (Rel), CTB:  $0\text{MHz}$  (Rel).

The Measurement Setup of CSO and CTB is done from Measurement Setups in the Configure menu (see page 3–70). Since the 2714 uses a single generic distortion measurement to measure both second and third order beats and distinguishes the two only by the specified test locations, the software uses the following rule to separate results from the 2714 generic distortion measurement:

Results measured at an absolute (Abs) frequency location or a relative (Rel) frequency location that lies within a frequency range determined by the CTB Measurement Setup are designated as CTB results. Results measured at a relative frequency location outside this frequency range are designated as CSO results.

The frequency range is determined from the current CSS500 CTB Measurement Setup for the channel as follows:

CTB Result Range =  $0\text{MHz} \pm (\text{Max CTB Test Location} + \text{Search Ambiguity})$

where,

Max CTB Test Location = The maximum absolute value of all the CTB relative test locations, as defined in the CSS500 CTB Measurement Setup for the result channel.

Search Ambiguity = The maximum frequency range over which the 2714 searches for beat maximums relative to the actual given test location. This is set to 100 kHz in the 2714.

CTB and CSO Measurement Setup Restrictions. To make the above scheme consistent, CTB and CSO test locations should not be allowed to overlap. Therefore, the CSO Measurement Setup is restricted as follows:

The allowed CSO test locations must lie outside the frequency range defined by the CTB Measurement Setup. This frequency range is determined as specified above except that the Search Ambiguity is doubled to 200 kHz (see Figure 3–48). This is because, in the worst case, a CTB signal may be found 100 kHz above the specified test location and a CSO signal may be found 100 kHz below another test location. This would result in an overlap of the CTB frequency range unless a 200 kHz ambiguity range (guard band) is enforced. Also, Absolute (Abs) test locations are allowed only in the CTB Measurement Setup.

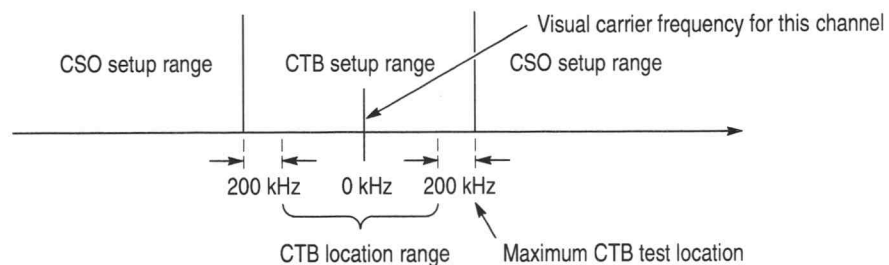

**Figure 3–48: CTB/CSO measurement results distribution and the CSO setup restrictions**

VITS Group (NTSC). It is important that the locations of the VITS signals are correct. In NTSC, if the locations are not correct, the VM700A will search for them, first using the VITS ID and then using a VITS Search. (The VITS Search has a wider search range than the VITS ID.) This slows down the measurement process. The VM700A will automatically enter the location of VITS when it finds them, so it will only have to search for them once. If the VITS cannot be found, the default line numbers are left alone and a note is placed in the Notes field (of the Results Detail Display) that the VITS line could not be found for this measurement.

---

**NOTE.** For the ICR measurement, if the VM700A cannot find  $\text{Sin}(x)/x$  using the VITS ID it then switches to looking for Multiburst during the VITS Search.

---

VM700A VITS Group (PAL). (See Figure 3–49.)



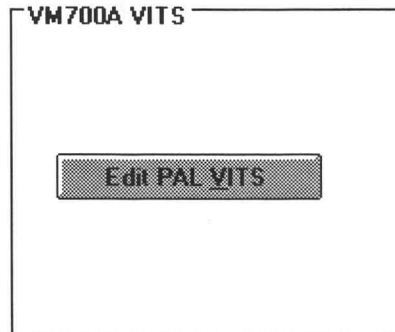

**Figure 3–49: The VITS group for a PAL system**

If the Channel Table specifies that you have a PAL system, the VITS group will only have an Edit PAL VITS command button in the VM700A VITS group box. The PAL version of the VM700A does not have a VITS ID application like the NTSC version does. The PAL VM700A does have a VITS search capability in individual measurement mode applications. The VITS search feature cannot be used in the same manner as the VITS ID application. This is because rather than identifying VITS and writing the results to one file, as VITS ID is designed to do, the VITS search feature is unique to each application and only looks for the proper test signal for each individual application. If a “correct” signal is found, the measurement begins and returns valid data. If the VITS search does not turn up a valid signal type, the application returns erroneous data along with an unpredictable test signal type. In other words, the VITS search feature can only be used to find the test signal for which the application was written.

The CSS500 baseband measurements are arranged into seven groups, with each group requiring a particular test signal as given in Table 3–10.

**Table 3–10: Required test signal for each measurement**

Group	Required Test Signal
Waveform Distortion Group	Any one of lines 10–23 or 320–335. Identified as “Composite” in Diff Gain/Diff Phase application.
Baseband Group	Any one of lines 10–23 or 320–335. Identified as “Pulse” in Chroma/Luma Gain Delay application for Chroma-Luma Gain and Delay, and then another identified in DGDP application for Diff Gain and Phase.
In-Channel Response Group	Any one of lines 10–23 or 320–335. Multiburst. Identified as “multiburst” in Multiburst application. Sin(x)/x not used when searching.
Modulation Depth	Any one of lines 10–23 or 320–335. Luminance Bar and Zero Carrier. Zero Carrier position fixed, and Bar identified as “Bar” in Bar LineTime application.

**Table 3–10: Required test signal for each measurement (Cont.)**

<b>Group</b>	<b>Required Test Signal</b>
Multiburst Group	Any one of lines 10–23 or 320–335. Identified as “Multiburst” in Multiburst application.
Signal to Noise Group	Any one of lines 6–23 or 320–335. Identify as “pedestal” in Noise Spectrum application. Needs to be done before any measurement has been taken. No way for measurement to tell whether a line is quiet or not.
ICPM	Any one of lines 10–23 or 320–335. Staircase signal, either modulated or unmodulated. Identified as “Composite” in the Diff Gain/Diff Phase application.

Choose the command button to edit the VITS lines and display the Edit PAL VITS dialog box as shown in Figure 3–50.

	Line	Pos. Rel. Sync
Luminance Bar <u>S</u> tart:	<input type="text" value="17"/>	<input type="text" value="12"/> uS
Luminance Bar <u>W</u> idth:		<input type="text" value="10"/> uS
Luminance Bar <u>R</u> eference:		<input type="text" value="17"/> uS
2T Sine-Squared <u>P</u> ulse:	<input type="text" value="17"/>	<input type="text" value="26"/> uS
5-Riser <u>L</u> um. Staircase:	<input type="text" value="17"/>	<input type="text" value="40"/> uS
5-Riser <u>M</u> od. Staircase:	<input type="text" value="330"/>	<input type="text" value="40"/> uS
Modulated <u>3</u> Step:	<input type="text" value="331"/>	
<u>Q</u> uiet Line:	<input type="text" value="22"/>	
Multiburst <u>L</u> ine:	<input type="text" value="18"/>	
Multiburst <u>F</u> lag:		<input type="text" value="12"/> uS
Multiburst Flag <u>W</u> idth:		<input type="text" value="8"/> uS
Multiburst Packet <u>1</u> :		<input type="text" value="14.5"/> uS
Multiburst Packet <u>2</u> :		<input type="text" value="20.5"/> uS
Multiburst Packet <u>3</u> :		<input type="text" value="26.5"/> uS
Multiburst Packet <u>4</u> :		<input type="text" value="32.5"/> uS
Multiburst Packet <u>5</u> :		<input type="text" value="38.5"/> uS
Multiburst Packet <u>6</u> :		<input type="text" value="44.5"/> uS
Sin <u>X</u> /X:	<input type="text" value="16"/>	

Figure 3-50: The Edit PAL VITS dialog box

See the VM700A opt 11 manual for more detailed explanations on these values.

Command Buttons for the Edit Setups for Channel XX Dialog Box. There are three special command buttons located on the upper right hand corner of the Edit Setups for Channel dialog box. They are Get Defaults, Save as Defaults, and Copy to All Channels.

Get Defaults. The Get Defaults command button takes the default values and places them in the text boxes. It also sets the option buttons to the default values. The dialog box below appears, allowing you to decide what measurements should get the default values. (See Figure 3-51.)

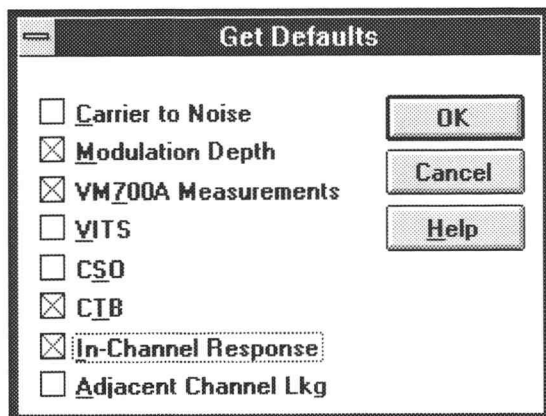

Figure 3-51: Get Defaults dialog box

Save as Defaults. This command button takes the current entries in the text boxes and selected check boxes and stores them as the default values. Load these default values into selected channels using the Get Defaults command button when you are editing the setups for those channels. These become the default values whenever a new worksheet is created. (See Figure 3-52.)

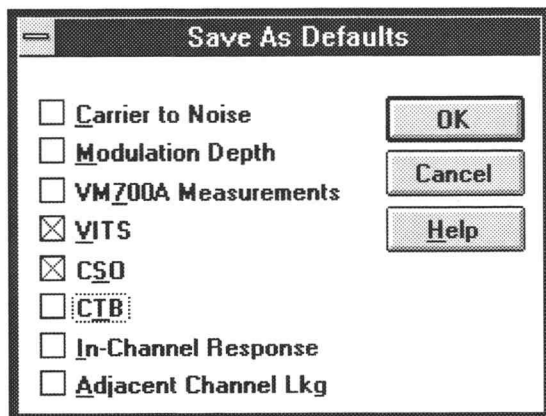

Figure 3-52: Save As Defaults dialog box

Copy to All Channels. The Copy to All Channels command button takes all of the settings for the selected measurements and copies the current values to all channels. (See Figure 3-53.) Note that CSO and CTB settings are handled in a special way. If the current channel is digital, CSO and CTB setups are copied only to digital channels. Similarly, if the current channel is analog, CSO and CTB setups are copied only to analog channels.

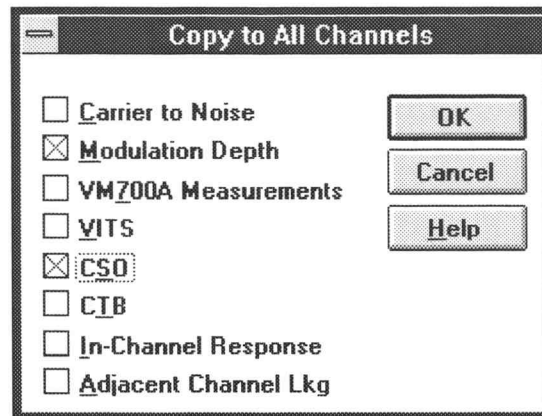

Figure 3–53: Copy to All Channels dialog box

### Connections

The Connections dialog box sets up the GPIB and RS-232 control connections for CSS500. The allowable GPIB addresses are from 0 to 29. Figure 3–54 shows the Connections dialog box when the TDC-10/1450A is selected as the demodulator. If any other demodulator is selected, it is reflected in the Demodulator group. If None is selected, then the whole Demodulator group is grayed out.



---

**CAUTION.** To ensure proper operation and prevent software conflicts, verify that no two instruments are assigned to the same port or GPIB address. This applies even if an instrument is not connected or used.

---

Figure 3–54: The Connections dialog box

#### 2714/2715 Spectrum Analyzer Group

- GPIB. If your system uses the GPIB, enter the address of the 271X in the GPIB Address text box.
- RS-232. If your 271X uses RS-232 instead of GPIB, select the correct Com port (1 – 4) from the Com Port list box and the correct baud rate from the Baud Rate list box.

#### VM700A Group

- GPIB Address. The GPIB address of the VM700A.

#### Demodulator Group

- GPIB Address. The GPIB address of the demodulator. The contents and availability of this group are determined by the selection made in Demodulator from the Configure menu.

**Switcher Control Port Group.** This group contains all of the parameters required to communicate with a switcher. See the documentation provided with the switcher for how these should be set. The Delay parameter is in seconds. For more information on using the switcher, please see *Switcher Control String* in Appendix C, on page C–31.

**RS-232 Violations Reporting Group.** This group sets the parameter for a port that will receive error messages from the CSS500 if one of the measurements is in a “non-standard condition”. Select the Com Port and the Baud Rate. For more information on the RS-232 Violations report, please see page 3–55.

**Demodulator** The Demodulator command selects between the supported demodulators (see Figure 3–55).

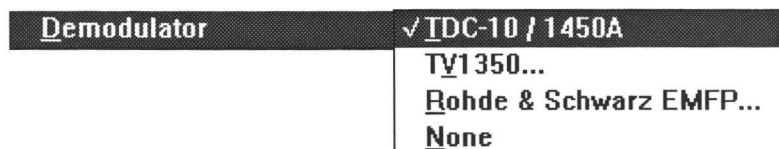

Figure 3–55: The Demodulator menu item

If None is selected, then during measurement execution, no checking is made for a demodulator. If a demodulator is selected, then during measurements the following occurs:

- If making an RF measurement, CSS500 will try to talk to demodulator, if it fails, no errors are reported and the measurements continue.
- If making a baseband measurement and the specified demodulator is not found, an error message is displayed and the measurement is terminated.

If either the TV1350 or the EMFP is selected, then an additional dialog box appears, as shown in Figure 3–56.

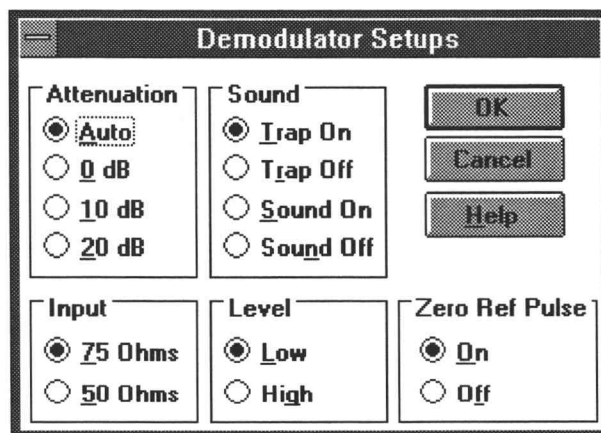

Figure 3–56: The Demodulator Setups dialog box

Set these values as required for your system. These values automatically override the front panel instrument settings.

### Execute

The Execute menu allows you to launch the Channel Table Editor without leaving the CSS500 application.

### Channel Table Editor

The Channel Table Editor is a separate application that allows you to edit and create Channel Tables to load into the instruments. This command launches this application or, if it is already started, this command switches to it. For more information on this application, please see Appendix C.

### Help

The Help menu (see Figure 3-57) provides access to the CSS500 online help.

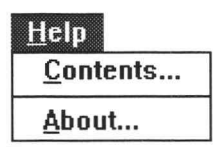
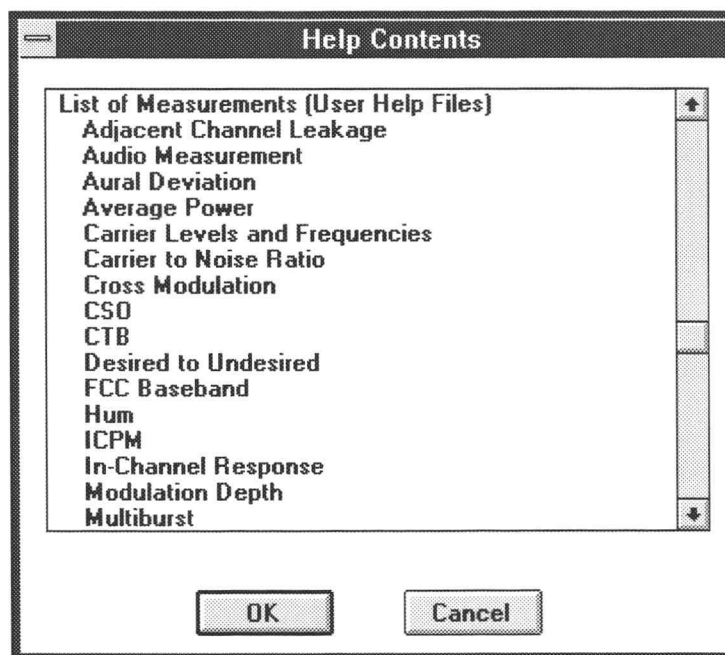

**Figure 3-57: The Help menu**

### Contents

Contents lists all of the available help topics (see Figure 3-58). These topics are accessed by scrolling until the desired topic is highlighted and then choosing the OK button or double clicking on the name. There are some general topics, then all the menus and their associated commands are listed. At the end of the list are the measurement help files. The measurement help files give a brief description of the measurement, and the files have room for you to add your own notes about the measurements. For details on editing these Help files, see *Adding Information to the Help Files*, in Appendix E, on page E-3.





**Figure 3–58: The Help Contents dialog box**

These same topics are available from the Help command buttons in most dialog boxes.

Make sure that you close the Help dialog box when you are finished. CSS500 will allow only one open dialog box at a time. Close the Help dialog boxes by choosing Close from the Help Window Control Box or by pressing ALT+F4.

**About** The About dialog box gives the version number of CSS500 and other information (see Figure 3–59). Choose the OK command button to leave this dialog box.

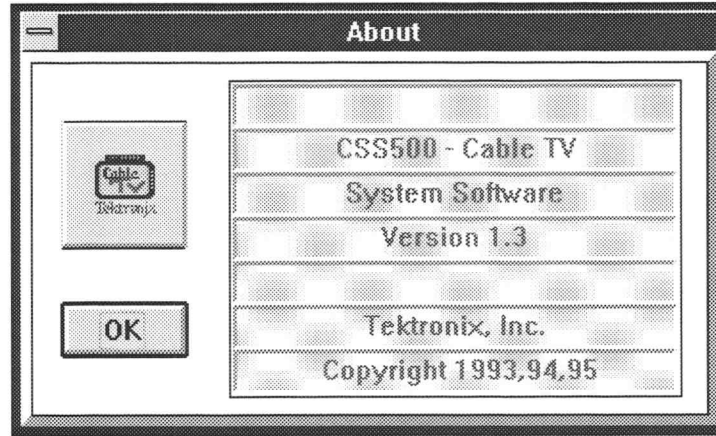

Figure 3-59: The About dialog box

### Button Bar

**Open**

The same as Open in the File menu on the Menu Bar. (See page 3-13.)

**Save**

The same as Save in the File menu on the Menu Bar. (See page 3-13.)

**Global**

The same as Global View in the View menu on the Menu Bar. (See page 3-39.)

**Results**

The same as Results Detail in the View menu on the Menu Bar. (See page 3-32.)

**Status**

Same as the Status Report in the View menu on the Menu Bar. (See page 3-26.)

**Meas Sel**

Same as Current Selection in the Measure menu on the Menu Bar. (See page 3-45.)

**Meas Seg**

Same as Measurement Sequence in the Measure menu on the Menu Bar. (See page 3-46)

**Test ID**

Same as Test ID in the Configure menu on the Menu Bar. (See page 3-52.)

**Setups**

Same as Measurement Setups in the Configure menu on the Menu Bar. (See page 3-70.)

**Limits**

Same as Measurement Limits from the Configure menu on the Menu Bar. (See page 3-64.)

**Print**

Same as Print in the File menu on the Menu Bar. (See page 3-17.)



# Appendices

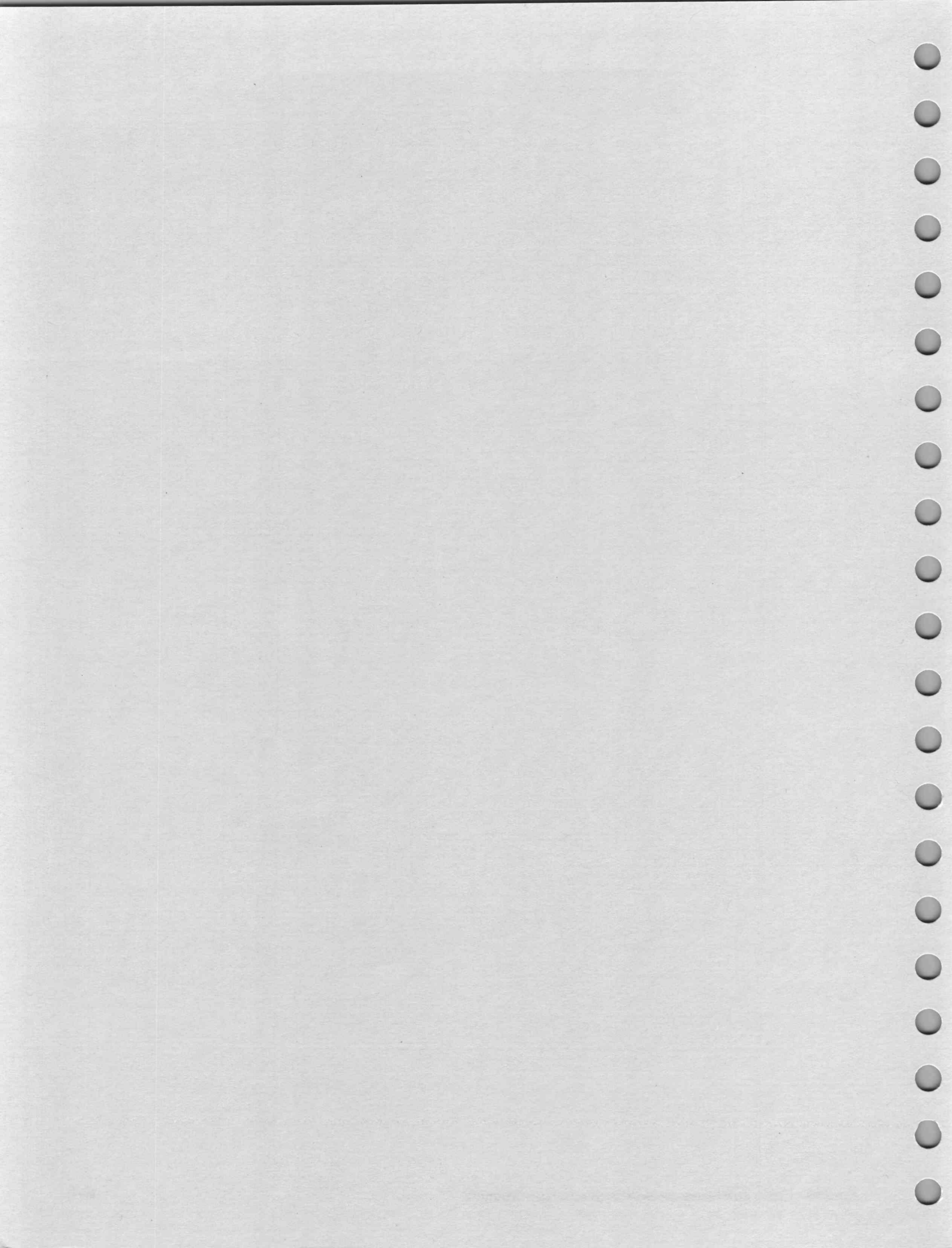

# Appendix A: Menu Map

This chapter is a quick reference to all of the commands available from the CSS500 Menu Bar along with a brief description of what they do.

**Table A-1: CSS500 Menu Bar menu map**

Menu	Command	Description
File	New	Creates a new worksheet. All Measurement Setups and Limits files are automatically set to defaults, instead of what is in the current worksheet.
	Open	Opens an existing worksheet and makes it active.
	Save	Saves all changes made to the current worksheet.
	Save As	Saves the current worksheet under a new name.
	Import	Imports data from stored results files into the current worksheet.
	Export	Exports the worksheet results data out to a ".wsr" file so that applications (such as Excel) can process the data.
	Print	Prints the worksheet on the selected printer.
	Print Setup	Sets up the printer.
	Exit	Exits the CSS500 application.
Edit	Copy	Copies the contents of the selected cells into the Windows Clipboard.
	Clear	Deletes the current value and/or all history for the selected cells.
	Select All	Selects all of the cells in the spreadsheet.
View	Status Report	The Status Report lists the extremes for all of the measurement results.
	Results Detail	The Results Detail dialog box displays more information about a measurement than can be contained in a cell on the spreadsheet. Also used to summarize individual measurements and channels.
	Global View	This is a condensed view of the standard spreadsheet display.
	2714/2715 Screen	Displays a copy of what is displayed on the 2714/2715 screen.
	Picture	The Picture command displays a video picture of what is presently on a given channel. (Requires video display hardware.)
	Measurements and Channels	This is a View Filter that determines which channels and measurements are on the spreadsheet. (Hides rows and columns on the spreadsheet.)
	Measurement Sequence Results	This is a View Filter that displays only those measurements made with the most recent Measurement Sequence execution.
	Test ID Results	This is a View Filter that displays only cells that have measurements tagged with the currently selected Test ID.
Row Header Fields	This command determines what channel information is given in the row header. It can include any combination of the following: Channel Number and Tag, Program Name, or Channel Frequency.	

Table A-1: CSS500 Menu Bar menu map (Cont.)

Menu	Command	Description
Measure	Current Selection	Executes measurements for the currently selected cells.
	Sequence	Executes the currently defined Measurement Sequence.
	Tune to Channel	Tunes the instruments to the selected channel.
	Get Stored Results from 2714/2715	Retrieves all the CATV measurement results currently stored in the NVRAM of the connected 2714 or 2715.
Configure	Worksheet Info	Enables you to specify worksheet Info such as the Site, Channel Table, and description for the current worksheet.
	Test ID	Brings up a dialog box that enables you to specify a test identifier such as Technician Name, Test Number, etc. There are two groups in the dialog box: All Test IDs and Worksheet Test ID. The All Test IDs group lists all of the Test IDs that have ever been used. The Worksheet Test IDs are the IDs used in the current worksheet.
	Preferences	Enables you to set preferences in the way results are collected and displayed.
	Measurement Sequence	Brings up a dialog box that enables you to program a set of measurements that will be executed as a Measurement Sequence. This allows a regularly used set of measurements to be called with a single keystroke.
	Measurement Limits	Brings up a dialog box that enables you to define the Alarm and Caution levels for the measurement results.
	Measurement Setups	Brings up a dialog box that enables you to control how measurements are executed in the instruments.
	Connections	Brings up a dialog box that enables you to set the GPIB and RS-232 control connections.
	Demodulator	This command selects which demodulator to use.
Execute	Channel Table Editor	Allows you to switch to or start the Channel Table Editor application.
Help	Contents	Lists all of the available help topics.
	About	Displays the CSS500 version number and other information.

# Appendix B: Error, Warning, and Informational Messages

The tables in this appendix explain the various types of messages you may encounter when using CSS500. In the following tables, the term **XX** represents information that is dependent on the situation. In practice, **XX** is replaced by an instrument name, filename, or number, as appropriate.

## Error Messages

Error messages tell you when CSS500 was unable to complete a task as required. These messages can occur because of equipment malfunctions, corrupted files, or missing information that must be supplied before CSS500 can continue.

**Table B-1: Error messages**

<b>Error Number</b>	<b>Error Message</b>	<b>Explanation</b>
E61	No GPIB0 Board Found	GPIB is not installed or the name of the GPIB board is not "GPIB0".
E62	GPIB is not System Control	GPIB card is not configured for System Controller.
E63	GPIB Write Error	A device on the GPIB has prevented data transfer. Check all instruments.
E64	GPIB Read Error	A device on the GPIB has prevented data transfer. Check all instruments.
E65	No Listener on Bus	No GPIB devices are connected to the controller or they are all turned off.
E66	GPIB Timeout, device not responding	Device too slow in responding to command. Instrument may need to be initialized.
E67	GPIB DOS Error	GPIB.DLL not found or incorrect version.
E68	GPIB General Failure	Problem with GPIB driver. Refer to National Instrument's GPIB manual for troubleshooting and possible reinstallation.
E103	RS-232 Write Error	Unable to write to the RS-232 device. Check Cable and device RS-232 settings.
E104	RS-232 Read Error	Unable to read from the RS-232 device. Check Cable and device RS-232 settings.
E105	RS-232 Timeout, device not responding	RS-232 device not responding in sufficient time. Device may need to be reinitialized.
E106	RS-232 port not available for this application.	RS-232 is in use by another application. Close down all other applications that use RS-232.
E220	Cannot communicate with XX.	Cannot communicate with specified instrument. Check that the settings in the Connections dialog match the instrument. Check that the cabling is correct.
E221	Unknown 2714/2715 firmware version.	The firmware version of the 2714 or 2715 is not recognized by the CSS500 software and therefore the current operation cannot proceed. Obtain the correct firmware version.

**Table B-1: Error messages (Cont.)**

<b>Error Number</b>	<b>Error Message</b>	<b>Explanation</b>
E222	Cannot allocate memory for 2714 /2715 stored results	System running low on memory. Try closing other applications.
E223	Stored results in 2714/2715 are corrupt	The results file(s) in the 2714/2715 are corrupt. The results could not be retrieved. You may need to delete all stored results from the 2714/2715.
E224	Existing 2714/2715 stored results partially loaded	Some, not all, existing 2714/2715 stored results were successfully loaded from the instrument. Usually indicates corrupt stored results. Remove the stored results from the 2714/2715.
E225	Cannot load existing 2714/2715 stored results	None of the stored results currently found in the 2714/2715 could be loaded. Usually indicates corrupt stored results. Remove the stored results from the 2714/2715.
E226	The selected channel cannot be set in the 2714/2715	2714/2715 failed to tune to the channel requested. Channel Table may be incorrect.
E227	The selected channel cannot be set in the TDC-10	TDC-10 failed to tune to the channel requested. Channel Table may be incorrect.
E228	The selected channel table cannot be set in the 2714/2715	Problem occurred in loading a Channel Table to the 2714/2715. Verify Channel Table with the Channel Table Editor (CTLOADE) application. Either the channel table is invalid, or there is no available slot in the instrument.
E229	The selected channel table cannot be set in the TDC-10	Problem occurred in loading a Channel Table to the TDC-10. Verify Channel Table with the Channel Table Editor (CTLOADE) application.
E230	You must manually delete duplicate UDP title: 'XX' first and then retry	There already is a UDP with that name loaded into the 2714/2715. If you really want to use that name delete the old name first.
E231	The UDP menu is full. You must manually delete a UDP from the 2714/2715 first and then retry.	The 2714/2715 only has room for 9 UDPs. Delete one or more before trying to load the UDP again.
E232	Reserved	
E233	UDP is too large to load, aborting operation	There is a limit on the number of measurements that can be in a UDP. Delete some of the measurements and try to reload.
E234	UDP may be too large to execute in the 2714/2715	Delete the UDP from the 2714/2715, remove some of the measurements from the Measurement Sequence, then reload the UDP.
E235	Gated setup option not available with 2714. Use Auto instead?	Gated Carrier to Noise and CSO measurements can only be made on the 2715. Enter Yes to run in Auto mode instead.
E236	Gated setup option not available with 2714. Turn gated off?	Gated In Channel Response measurements can only be made on the 2715. Enter Yes to run without Gated mode.
E237	Reserved	



Table B-1: Error messages (Cont.)

Error Number	Error Message	Explanation
E239	<p>The following problems were found in the Measurement Sequence:</p> <p>The Gated setup option is not supported by 2714s. C/N, CSO and ICR will be run in the non-gated mode</p> <p>Digital measurements are not supported by the attached 2714/2715. All digital tests (Avg Pwr, D/U and ACL) will be skipped</p> <p>Only RF measurements are supported by the 2714s and 2715s. All non-RF measurements (FCC Baseband, S/N, Wfm Dist, Multiburst, ICPM, and Audio) will be skipped</p> <p>See the Create 2714/2715 UDP help topic for additional details</p>	<p>When creating a 2714 UDP, one or more Carrier to Noise, CSO, or In Channel Response measurements specified Gated measurement setups. Since this is not supported by the 2714, the setup was changed to run without the gated option.</p> <p>One or more Average Power, Desired to Undesired, or Adjacent Channel Leakage measurements were requested. These digital tests are not supported by 2714s and are not supported by 2715s with Firmware Version 09.30.94 or earlier. The UDP may still be generated, but the digital measurements will be skipped.</p>
E240	Reserved	
E241	Reserved	
E242	Unknown response received from 271X	The content of the query response was not what was expected. Try the operation again.
E300	Error initializing CSS500.	The file has become corrupted. Try reloading the application from the master disk.
E301	271X_SW or CSS500 already running.	Only one copy of the 271X_SW or CSS500 software can be run at a time. Either use the software that is already open, or exit it before continuing.
E302	Error creating window.	Running low on memory. Try closing other applications.
E303	Memory allocation error, operation canceled.	Running low on memory. Try closing other applications.
E304	Instrument connections could not be initialized.	Check the instrument's connections and the cabling. Make sure that the address is correct.
E305	Error opening file: XX.	The file is corrupt or not in the proper format. File cannot be found.
E306	Error closing file: XX	The file as been corrupted or the computer is out of memory space.
E307	Error writing file: XX Possibly out of disk space.	Free some disk space and then try again.
E308	Corrupted data in file: XX.	The file is not in the correct format.
E309	End of file encountered in file: XX.	The file has been corrupted.

**Table B-1: Error messages (Cont.)**

<b>Error Number</b>	<b>Error Message</b>	<b>Explanation</b>
E310	XX file XX is not valid	The file is corrupt or the wrong file type. File is found but it is the wrong file type.
E311	One or more Limits files not found or invalid	The limits files requested in the current worksheet either are not in the correct directory, in the correct format, or don't exist. Limits files must be in the Limits sub-directory of the executable file.
E312	Error writing CSS500.INI file	Out of memory or the application is corrupted.
E313	Error writing WIN.INI file	File has been corrupted.
E314	Invalid number	The text box is expecting either a number or a letter and received the other. Retry with valid data.
E315	Number out of range. Enter a number between XX and YY	Enter a valid number.
E316	CSO offset fell within CTB range of +/- XX MHz	Change the CSO offset so that it is outside of the CTB range or change the CTB range.
E317	Site cannot be blank	Blank is not a valid Site name. Enter one or select <undefined>.
E318	Test ID cannot be blank	Blank is not a valid test ID. Enter one or select <undefined>.
E319	UDP title cannot contain commas or semicolons, and cannot be blank	Change the UDP title in the text box to remove the invalid characters.
E320	Undefined measurement ID	The measurement ID does not exist.
E321	Creation and loading of UDP 'XX' failed	The UDP could not load. Check the 2714/2715 for adequate UDP (NVRAM) space.
E322	Maximum number of measurements stored in Worksheet, operation canceled	A Worksheet will only hold 16,000 measurements. Any measurements previously made have been loaded. Create a new Worksheet or delete some measurements before continuing.
E323	Maximum amount of clipboard data has been exceeded	Try using the Export command instead of the Copy command to move data into other applications, or select smaller blocks of data to copy.
E324	An error occurred while copying data to the clipboard	The clipboard data is invalid. Try again.
E325	An error occurred while clearing measurement for row XX column XX	The measurements could not be cleared.
E326	Select a cell, entire column, or entire row	The Results Detail display needs to know what information you want.
E327	No Limits file selected	Select a Limits file from the combination box, before choosing Select Limits File.
E328	Select at least one measurement and channel for viewing	The View Filter will not allow a blank data display. Pick at least one measurement and one channel from the selections.
E329	No stored results selected	Select one of the stored results directory entries from the 271X to export.
E330	Error initializing help	Files are corrupted.
E331	Only 1 help window may be open at a time	Close the open help window before trying to open another one. The Help window may be under another window.

Table B-1: Error messages (Cont.)

Error Number	Error Message	Explanation
E332	Help topic not found	The Help file has been lost. Make sure that there is a help sub-directory in the CSS500 executable directory. Check to see if there are any *.hlp files in that sub-directory.
E333	Video driver XX not active	The Video driver must be running before Picture, from the View menu, can activate. Make sure that your Video driver is one that is supported by this application. Make sure that the Video driver title from the Switch To window for the Video driver is the same name as is in the CSS500.INI file.
E334	Channel Table Editor not found	The Channel Table Editor application (CTLOADE) is not in the CSS500 executable directory.
E335	Error printing report	An error occurred printing a report. Ensure that print options were appropriately selected and the printer is correctly connected to the PC.
E336	Channel Table file XX not found or is invalid	The Channel Table requested either cannot be found or is corrupt. Request another Channel Table and try again.
E337	Default Channel Table file 'XX' is not found or is invalid	The default Channel Table either cannot be found or is corrupt. Request another Channel Table and try again.
E338	No Audio Limits file selected	Select an Audio Limits filename for the combination box before selecting Select Audio Limits.
E339	Cannot communicate with VM700A. Audio Limits files not updated.	When attempting to request a list of audio files from the VM700A, the instrument could not be found.
E340	Limits relationship violated: XX >= YY	Caution and Alarm lower and upper limits must adhere to the relationship: Alarm lower limit < Caution lower limit < Caution upper limit < Alarm upper limit.
E341	Select one or more check boxes	Select at least one check box to indicate which item(s) should be used.
E1000	Error opening file: 'XX'	The file is corrupt or not in the proper format.
E1001	Memory allocation error, operation canceled	Running low on memory. Try closing other applications.
E1011	Number out of range. Enter a number between XX and YY	Enter a number between the stated limits.
E1012	Error writing file: XX Possibly out of disk space	The stated file could not be written.
E1013	XX file XX is not valid	The stated file is corrupt or of the wrong type.
E1014	Error initializing help	Help files are corrupted.
E1015	Only 1 help window may be open at a time	Close the open Help window before trying to open another one. The Help window may be under another window.
E1016	Help topic not found	The Help file has been lost. Make sure that there is a help sub-directory in the CSS500 executable directory. Check to see if there are any *.hlp files in that sub-directory.
E1017	Error creating window	Running low on memory. Try closing other applications.
E1018	Error writing CTLOADE.INI file	Out of memory or the application is corrupted.
E1019	Error writing WIN.INI file	File has been corrupted.

Table B-1: Error messages (Cont.)

Error Number	Error Message	Explanation
E1020	CTLOADE already running	Only one copy of CTLOADE can be run at a time. Use the copy that is already open.
E1023	Error printing spreadsheet	An error occurred printing a report. Ensure that print options were selected appropriately, and that the printer is properly connected to the PC.
E1024	Invalid channel table name	The channel table filename specified is not valid.
E1025	Attempted write to read-only file	The Channel Table file is write protected. Select a different save file name.
E1026	Table Info was incomplete in the selected file	A Channel Table file must have table information for at least one channel. The file may be corrupt.
E1027	Selected file has too many channels — truncated	The Channel Table file has more channels than the application can handle. All possible channels were loaded.
E1028	Error initializing CTLOADE	One or more executable files have become corrupted. Try reloading the application from the master disk.
E1029	Select at least one item or press CANCEL	This dialog requires a selection.
E1030	Selected table name is too long or contains incompatible characters	A Channel Table being read into the application from an instrument has a name which cannot be converted into a DOS-compatible file name.
E1031	No channel tables found in instrument	For Transfer:Delete operation, there are no Channel Tables in the specified instrument which can be deleted. For Transfer:From operation, there are no Channel Tables in the instrument of any type.
E1032	GPIB is non-functional or not installed	GPIB was selected for communicating with the selected instrument, but is not installed for Windows.
E1033	Cannot expand table further (500 Channels Max)	The application cannot handle more channels.
E1034	No filename has been defined — Save file first	CTLOADE cannot send a Channel Table to an instrument until a filename has been defined (since this is where the table name is derived from). Save the Channel Table to a file first, then transfer to an instrument.
E1035	Channel Table 'XX' contains one or more invalid fields. Use Limit Check to verify.	When opening the Channel Table file, one or more fields were found to not meet the limits or data type requirements. Use Limit Check to find out which field(s) were invalid.
E1040	Channel Table File Read Error: XX	The Channel Table is corrupt at the specified line and column.
E1041	Directory read error in XX	Could not read the Channel Table directory in the specified instrument.
E1042	Attempted write to read-only table in XX	The specified Channel Table cannot be overwritten. Select a new file name, from which the instrument Channel Table name is derived.
E1043	All channel table slots used in XX. Delete a table first	Cannot send a table to the specified instrument, since all Channel Table slots are used.
E1045	Channel Table name too long for XX (YY characters max)	The Channel Table name is too long for the specified instrument. Select a shorter file name and retry.
E1046	Incompatible video standard for XX	The Video Standard for the stated channel is incompatible with the stated instrument.

Table B-1: Error messages (Cont.)

Error Number	Error Message	Explanation
E1047	Incompatible channel width for XX. Enter a number between XX and YY	The Channel Width for the stated channel is incompatible with the stated instrument.
E1048	Incompatible aural offset for XX. Enter a number between XX and YY	The Aural Offset for the stated channel is incompatible with the stated instrument.
E1049	Incompatible channel number for XX. (record YY) Enter a number between XX and YY	The Channel Number for the stated channel is incompatible with the stated instrument.
E1050	Incompatible visual frequency for XX. (record YY) Enter a number between XX and YY	The Visual Carrier Frequency for the stated channel is incompatible with the stated instrument.
E1051	Incompatible lower channel edge for XX. (record YY) Enter a number between XX and YY	The lower channel edge for the stated channel is incompatible with the stated instrument. The lower channel edge is calculated by adding the Channel Edge parameter with the Visual Carrier Frequency parameter.
E1052	Incompatible channel type for XX. (record YY)	The Channel Type for the stated channel is incompatible with the stated instrument.
E1053	Incompatible test pulse offset frequency for XX. (record YY) Enter a number between XX and YY	The test pulse offset frequency for the stated channel is incompatible with the stated instrument.
E1054	Incompatible channel-specific aural offset for XX. (record YY)	The Aural Offset for the stated channel is incompatible with the stated instrument.
E1055	Channel Edge out of range for XX. (record YY) Enter a number between XX and YY	The channel edge for the stated channel is incompatible with the stated instrument.
E1056	Incompatible channel tag for XX. (record YY)	The tag for the stated channel is incompatible with the stated instrument. For a 2721A, every channel must have a tag and must consist of characters 'A' through 'Z' and '0' through '9' only.
E1057	Incompatible second aural offset for XX. (record YY) Enter a number between XX and YY	An invalid value was detected for the second aural offset. Enter a valid selection.
E1058	Incompatible C/N bandwidth for XX. (record YY) Enter a number between XX and YY	The C/N bandwidth for the stated channel is incompatible with the stated instrument.
E1059	Incompatible amplitude offset for XX. (record YY) Enter a number between XX and YY	The amplitude offset for the stated channel is incompatible with the stated instrument.
E1060	Channels must be in frequency order for XX. (record YY)	All channels for the stated instrument must be listed in order of ascending visual carrier frequency. The stated channel (at least) is out of order.
E1061	Too many channels in XX, table XX	The Channel Table in the specified instrument contains more channels than the application can handle.
E1062	Too many channels in file XX	The Channel Table file has more channels than the application can handle.
E1063	Too many channels for XX	The specified instrument cannot store all of the channels in the current Channel Table.

**Table B-1: Error messages (Cont.)**

<b>Error Number</b>	<b>Error Message</b>	<b>Explanation</b>
E1064	Incomplete channel table information	The application read all of the Channel Table information possible, but was not able to read all channels.
E1065	Channel Table XX is unavailable. Select it in the YY and try again	The read-only channel tables in the 2714/2715 are not readable via RS-232 or GPIB unless they are selected first. Select the table via the 2714/2715 menu system and try again.
E1066	Transfer was incomplete — Unknown Error	The channel table was transmitted to the instrument, but was not found in the instrument when checked at a later time.
E1067	Invalid GPIB Address for XX	Check the Connections information for the instrument in the Transfer: Connections menu selection.
E1068	Channel Table is in use in instrument XX and cannot be deleted or overwritten	Select a different table in the instrument before attempting to delete or overwrite the table.
E1069	Channel Table name is incompatible with XX	Some of the characters in the Channel Table name are inappropriate for the stated instrument. For a 2721A, only characters A–Z, 0–9, and underscore are allowed.
E1070	Channel Tables in the XX are incompatible with this version	All channel tables in the stated instrument are incompatible with the current version of CTLOADE.
E1071	Channel Table XX already exists. Delete it first	When attempting to transfer a channel table to an instrument, a channel table with the same name was found. Delete it from the instrument first.
E1072	Cannot overwrite an XX NVRAM Fixed table	When attempting to transfer a channel table to an instrument, a fixed channel table of the same name was found. Enter a different name to transfer the table to the instrument.
E1073	Incompatible second aural offset for XX. (record YY)	For the 2714/2715, the second aural offset must be a number within the acceptable range.
E1074	Incompatible quiet line with XX. (record YY) Enter a number between XX and YY	Enter a number within range.
E1075	Incompatible white line with XX. (record YY) Enter a number between XX and YY	Enter a number within range.
E1076	Incompatible ICR test line with XX. (record YY) Enter a number between XX and YY	Enter a number within range.
E1077	More than 200 Include in Transfer channels entered for file 'XX'	Only 200 channels in the channel table can be marked include in transfer since this is a limitation of all the instruments which support channel tables. 500 are allowed as long as 300 are marked not include in transfer. These would be used to specify control strings to switchers.
E1078	Duplicate channel numbers are not allowed for XX. (There are duplicate channel number YY's.)	Assign unique channel numbers to each channel.
E1080	Multiple channel widths are incompatible with THIS 2714/2715 (1st difference at record nnn)	2714 and 2715 instruments with firmware versions 09.29.94 and earlier will not accept multiple channel widths. Use the Copy Field to End command to make all widths the same.

## Warning Messages

Warning messages tell you when CSS500 needs additional information from you before it can continue or that, if you continue, there may be a loss of information or settings because of the action being taken.

**Table B–2: Warning Messages**

Warning Number	Warning Message	Explanation
W350	Worksheet has changed. Do you wish to save it?	Save your changes or they will be deleted.
W351	Limits have changed. Do you wish to save them?	Save the changes or they will be deleted and the Limits file will revert to its previous values.
W352	Attempt to save the Worksheet and exit the application	Memory is getting full. Save what you can and exit CSS500. Then attempt to restart the application.
W353	Selected items will be copied to all channels. Proceed?	Whatever was previously in those channels will be overwritten.
W354	Import site: XX does not match worksheet site: XX Continue importing results?	All of the data being imported will be given the current worksheet Site if the import continues.
W355	Should worksheet site: XX be changed to import site: YY ?	You can change the worksheet Site name to match the import site name. If you do, any data previously in the worksheet will be associated with the new Site name.
W356	Import channel table: XX does not match worksheet channel table: YY Continue importing results?	The results will be loaded into any channel numbers that match. Data without a channel match in the worksheet is ignored.
W357	Do you want to turn the Sequence view filter on?	The Sequence View Filter will allow you to see only the results of the Measurement Sequence and not the entire spreadsheet.
W358	Do you want to turn measurement history collection on?	Older data will be overwritten if the Measurement History collection is not turned on.
W359	If you have edited your worksheet Channel Table, changes will not take effect until you create a new worksheet	The Channel Table was edited and has changed (although the name has not changed); you should put the edited Channel Table in a new Worksheet.
W360	No channels found which match the specified Carrier Level Difference Parameters	This would occur if the Channel Table included all analog channels and you selected the Digital Channels Only from the Parameters dialog box. It affects the Max, Min, and Max-Min values which would be displayed as blanks.
W361	No channels found which match the specified Adjacent Channel Difference Parameters	This would occur if either no adjacent channels fell within the specified adjacent channel window, or if there weren't two channels within the range which were of the specified channel type. The results will be displayed as blanks.
W362	If you edit your worksheet channel table, changes will not take effect until you create a new worksheet	When making most changes to the worksheet channel table, it is necessary to create a new worksheet to have those changes take effect.

**Table B-2: Warning Messages (Cont.)**

Warning Number	Warning Message	Explanation
W363	Carrier levels have been selected on all channels. Run Survey instead?	Your measurement selection includes carrier levels on all channels. You can run a survey substantially faster. Possible drawbacks are that all results have the same date/time stamp and the spreadsheet is not updated until the survey completes. Select Yes to run the Survey, or No to run individual carrier level measurements on each channel.
W1100	Channel Table changed. Do you wish to save it?	Answer YES, if the current Channel Table is to be saved to a file.
W1101	Multiple channel widths are incompatible with some 2714/2715 (first difference at record nnn)	The channel table contains more than one channel width. 2714 and 2715 instruments with firmware versions 09.29.94 or earlier will not accept a channel table with multiple channel widths. (See error 1080 on page B-8.)

## Informational Messages

Informational messages tell you when something has changed; for example, when a file import has been completed.

**Table B-3: Informational Messages**

Message	Explanation
Instrument connections have been changed.	The connection information of the equipment has been changed in the Channel Table Editor.
Import complete. XX results imported.	The data has been loaded into the worksheet.
Import complete. XX results imported.  Note: Some results were not imported due to Channel Header Mismatch.	This message appears at the end of an import. It only appears if there were mismatches in the Channel Table Header (channel number, frequency, tag, or program). For most of these cases, mismatches are flagged during the import process and you are allowed to overwrite any mismatches. The exception is channel number. If the channel number does not match, then it is simply skipped and you are not flagged except for this message.
There are no measurements for the selected view.	The View Filter must have some valid measurements and channels before it is allowed to be enabled.
There are no more measurements for the selected view. Removing View Filter.	After clearing the selected cells, the View Filter is no longer valid. It will revert back to normal view.
A tunable channel cannot be determined from current selection.	More than one channel has been selected. Select one cell, then try again.
No stored results were retrieved from the 2714/2715.	No results files or they were empty.
Only a sequence may be executed when the sequence view filter is active.	No other measurement can be made.
A sequence has not been defined.	You cannot run a Measurement Sequence. Use Measurement Sequence, from the Configure menu, to create a Measurement Sequence.



**Table B-3: Informational Messages (Cont.)**

<b>Message</b>	<b>Explanation</b>
Some of the imported results may not be displayed due to an active view filter.	You may have imported more data than is displayed. Turn the View Filter off to display all of the data.
Default Limits file XX not found or invalid.	Create a new Limits default file by choosing the Save As Default Limits command button, from the Edit Limits File dialog box
Limit check passed for all specified instruments.	All parameters in the Channel Table were within limits for all selected instruments.
No remote Channel Table delete on a 2721A. See 2721A/2722A manual for delete instructions.	



## Appendix C: Channel Table Editor

The purpose of Channel Table Editor is to create and edit Channel Tables, not only for CSS500 but also for CSS150 and other instruments. You create Channel Tables in the Channel Table Editor and then load them into the test equipment for automated testing and measurement gathering. Although CSS500 can call the Channel Table Editor, it is also a standalone application.

What's in this appendix:

- Starting the Channel Table Editor
- Creating a new Channel Table
- Editing an existing Channel Table
- Loading a Channel Table into the test equipment
- Notes on usage
- Channel Tables provided with CSS500
- Overview of the Channel Table Editor commands

## Starting the Channel Table Editor

To start the Channel Table Editor, select Channel Table Editor from the Execute menu or Create/Edit Channel Table from the Worksheet Info dialog box of the Configure menu. The Create/Edit Channel Table command button calls the Channel Table Editor. (It can be called independently from the Program Manager, using CTLOADE.EXE.)

**NOTE.** When starting from the Worksheet Info dialog box, it is not good practice to type a name into the combo box on the Worksheet Info dialog box before going into the Channel Table Editor. Select a name from the list provided. You can change Channel Tables once you've entered the Channel Table Editor. Always include the ".cht" filename extension.

The results (with the standard Channel Table std.cht loaded) are in Figure C-1.

Rec #	Chan #	Program	Tag	Visual or Center Freq (MHz)	Chan Width (MHz)	Channel Edge (MHz)	2714/2715 Channel Type	RFM150 Channel Type	Aural Offset (MHz)	2714/2715 Second Aural (MHz)	RFM150 Second Aural (MHz)	Scramble
1	2			55.250000	6.000	-1.250000	CATV	NTSC	4.5	0.00	None	No
2	3			61.250000	6.000	-1.250000	CATV	NTSC	4.5	0.00	None	No
3	4			67.250000	6.000	-1.250000	CATV	NTSC	4.5	0.00	None	No
4	5			77.250000	6.000	-1.250000	CATV	NTSC	4.5	0.00	None	No
5	6			83.250000	6.000	-1.250000	CATV	NTSC	4.5	0.00	None	No
6	95		A5	91.250000	6.000	-1.250000	CATV	NTSC	4.5	0.00	None	No
7	96		A4	97.250000	6.000	-1.250000	CATV	NTSC	4.5	0.00	None	No
8	97		A3	103.250000	6.000	-1.250000	CATV	NTSC	4.5	0.00	None	No
9	98		A2	109.250000	6.000	-1.250000	CATV	NTSC	4.5	0.00	None	No
10	99		A1	115.250000	6.000	-1.250000	CATV	NTSC	4.5	0.00	None	No
11	14		A	121.250000	6.000	-1.250000	CATV	NTSC	4.5	0.00	None	No
12	15		B	127.250000	6.000	-1.250000	CATV	NTSC	4.5	0.00	None	No
13	16		C	133.250000	6.000	-1.250000	CATV	NTSC	4.5	0.00	None	No

Figure C-1: The main window of the Channel Table Editor

## Creating a New Channel Table

Use the following procedure to create a new channel table which is not based on an existing channel table.

### Clear the Channel Table

From the File menu, choose New. This clears the Channel Information and loads the default values into the Table Information.

### Edit the Table Information

1. Choose the Edit Table Information command button from the Button Bar. This displays the Edit Table Information dialog box as shown in Figure C-2.

Figure C-2: The Edit Table Information dialog box

2. Enter a name for the new Channel Table in the Table Name text box. (For this example, use “test1.cht.”)
3. Enter the number of channels.
4. Edit the Aural Offset and Channel Width text boxes with the appropriate values for your system.
5. Select the correct Video Standard option button, either NTSC or PAL.
6. If you plan to use the Channel Table with a TDC-10, select the TDC-10 Aural Offset from the drop-down list box.
7. Choose the OK command button to save the changes and exit the Edit Table Information dialog box.

**Edit a Channel** 1. Start with the first channel as shown in Figure C-3.

Rec #	Chan #	Program	Tag	Visual or Center Freq (MHz)	Chan Width (MHz)	Channel Edge (MHz)	2714/2715 Channel Type	RFM150 Channel Type	Aural Offset (MHz)	2714/2715 Second Aural (MHz)	RFM150 Second Aural (MHz)	Scramble
1					6.000	-1.250000	CATV	NTSC	4.5	0.00	None	No
2					6.000	-1.250000	CATV	NTSC	4.5	0.00	None	No
3					6.000	-1.250000	CATV	NTSC	4.5	0.00	None	No
4					6.000	-1.250000	CATV	NTSC	4.5	0.00	None	No

Figure C-3: The test1.cht Channel Table before beginning the edits

2. Enter the Number, Visual Frequency, Tag, and Program text boxes.
3. Fill in the rest of the data by selecting the cell and either selecting from the drop-down list box or entering data in the text box. (See page C-29 for more details on the various Channel Table fields.)

**NOTE.** If you are using the keyboard, use ALT+↓ to open the field's drop-down list boxes.

4. Choose the OK command button to save the changes. The application window now looks similar to Figure C-4.

Rec #	Chan #	Program	Tag	Visual or Center Freq (MHz)	Chan Width (MHz)	Channel Edge (MHz)	2714/2715 Channel Type	RFM150 Channel Type	Aural Offset (MHz)	2714/2715 Second Aural (MHz)	RFM150 Second Aural (MHz)	Scramble
1	2XXX	XYZ		55.250000	6.000	-1.250000	CATV	NTSC	4.5	0.00	None	No
2					6.000	-1.250000	CATV	NTSC	4.5	0.00	None	No
3					6.000	-1.250000	CATV	NTSC	4.5	0.00	None	No
4					6.000	-1.250000	CATV	NTSC	4.5	0.00	None	No

Figure C-4: The Channel Table Editor with one channel's data entered

## Creating a Channel Table from an Existing Channel Table

In the previous section you learned how to edit a Channel Table. While you can create a channel table from scratch, it would take a long time to do so, editing one channel at a time. It is much easier to take an existing Channel Table and edit it to conform to your needs.

### Editing an Existing Channel Table

1. From the File menu, choose Open. The dialog box shown in Figure C-5 appears.

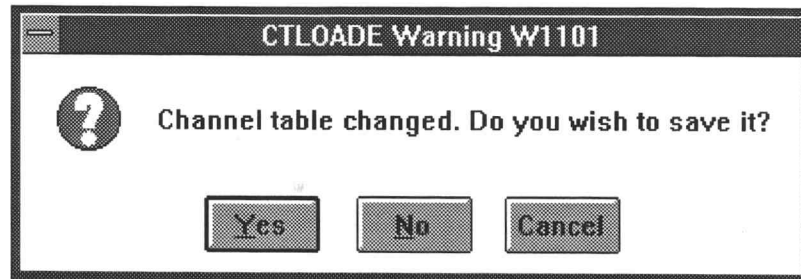

Figure C-5: Warning that you have made changes and not saved them

2. Choose the No button (you don't need to save the practice work). Next, the Open dialog box appears. See Figure C-6.

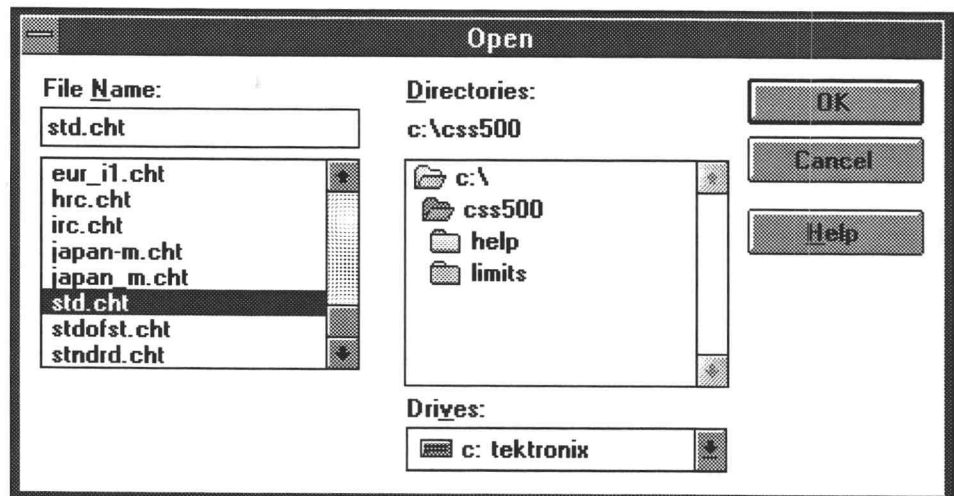

Figure C-6: The Open dialog box

3. Select "std.cht" from the File Name list box. This Channel Table comes with the CSS500 application.

- Choose the OK command button. The Channel Table will load and will appear similar to Figure C-7.

Rec #	Chan #	Program	Tag	Visual or Center Freq (MHz)	Chan Width (MHz)	Channel Edge (MHz)	2714/2715 Channel Type	RFM150 Channel Type	Aural Offset (MHz)	2714/2715 Second Aural (MHz)	RFM150 Second Aural (MHz)	Scramble	RFM150 CN BW (MHz)	Ampl Offset (dB)
1	2			55.250000	6.000	-1.250000	CATV	NTSC	4.5	0.00	None	No	4.0	0.0
2	3			61.250000	6.000	-1.250000	CATV	NTSC	4.5	0.00	None	No	4.0	0.0
3	4			67.250000	6.000	-1.250000	CATV	NTSC	4.5	0.00	None	No	4.0	0.0
4	5			77.250000	6.000	-1.250000	CATV	NTSC	4.5	0.00	None	No	4.0	0.0
5	6			83.250000	6.000	-1.250000	CATV	NTSC	4.5	0.00	None	No	4.0	0.0
6	95	A5		91.250000	6.000	-1.250000	CATV	NTSC	4.5	0.00	None	No	4.0	0.0
7	96	A4		97.250000	6.000	-1.250000	CATV	NTSC	4.5	0.00	None	No	4.0	0.0
8	97	A3		103.250000	6.000	-1.250000	CATV	NTSC	4.5	0.00	None	No	4.0	0.0
9	98	A2		109.250000	6.000	-1.250000	CATV	NTSC	4.5	0.00	None	No	4.0	0.0

Rec #	Chan #	Program	Dwell Time	Use White	White Line	Use Quiet	Quiet Line	Use ICR	ICR Test Line	Video Polarity	Sync Polarity	Test Pulse Offset	Offset Freq (MHz)	Include in Xfer	Switcher Control String
1	2		Short	No	0: No	No	0: No	No	0: Minus	Plus	No	0.00	Yes		
2	3		Short	No	0: No	No	0: No	No	0: Minus	Plus	No	0.00	Yes		
3	4		Short	No	0: No	No	0: No	No	0: Minus	Plus	No	0.00	Yes		
4	5		Short	No	0: No	No	0: No	No	0: Minus	Plus	No	0.00	Yes		
5	6		Short	No	0: No	No	0: No	No	0: Minus	Plus	No	0.00	Yes		
6	95		Short	No	0: No	No	0: No	No	0: Minus	Plus	No	0.00	Yes		
7	96		Short	No	0: No	No	0: No	No	0: Minus	Plus	No	0.00	Yes		
8	97		Short	No	0: No	No	0: No	No	0: Minus	Plus	No	0.00	Yes		
9	98		Short	No	0: No	No	0: No	No	0: Minus	Plus	No	0.00	Yes		

Figure C-7: The std.cht Channel Table (with all fields shown)

- From the File menu, choose Save As. The dialog box looks similar to Figure C-8.



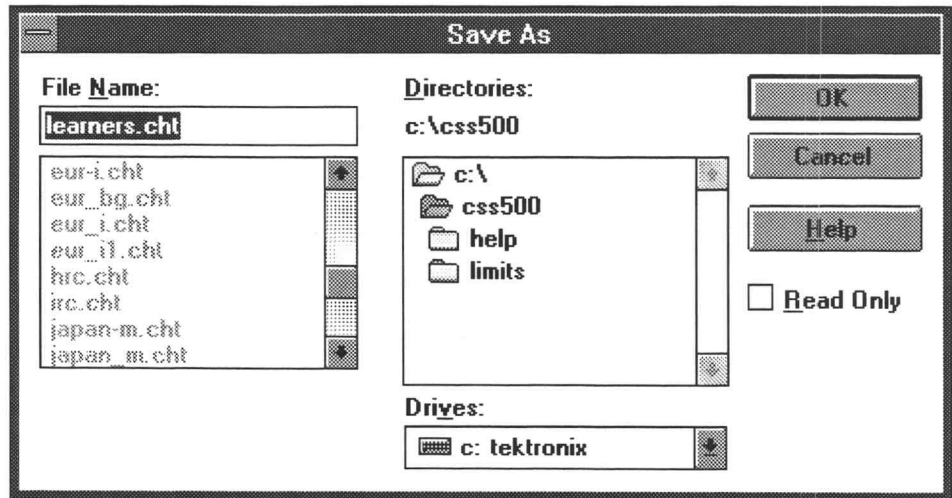

Figure C-8: The Save As dialog box

6. Enter “learners” in the File Name text box.

---

**NOTE.** The Channel Table Editor automatically adds the “.cht” filename extension.

---

7. Choose the OK command button to save the changes and leave the Save As dialog box. Changes are made in your learners.cht and not the std.cht file.
8. Select the first channel and make any changes that might be required for your system.
9. Repeat these steps for all channels in your system.
10. If any fields are the same for all channels, choose the Copy Fields command button from the Button Bar. Figure C-9 shows the resulting dialog box.

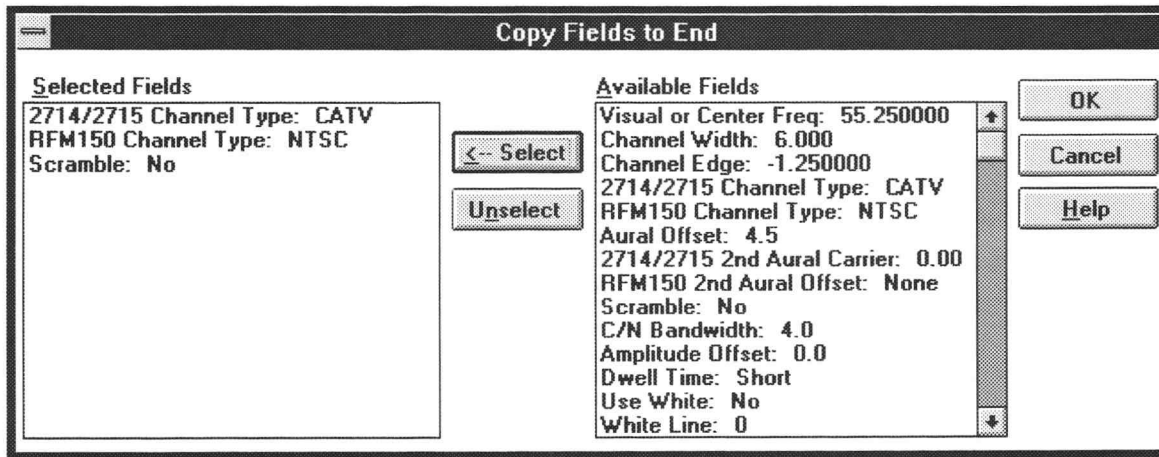

Figure C-9: The Copy Fields to End dialog box

11. Select all of the fields you want to be the same as the channel that you are editing.
12. Choose the OK command button to copy these fields to all channels below it in the Channel Table.
13. If there are any channels that are not in your system, select the channel (by clicking on the REC # cell) and choose the Delete command button to remove them.
14. From the File menu, choose Save to save the edited Channel Table.

## Loading a Channel Table into the Test Equipment

Now that you have created a custom Channel Table for your system, you must load it into the test equipment.

1. From the Transfer menu, choose To. The dialog box shown in Figure C-10 appears.

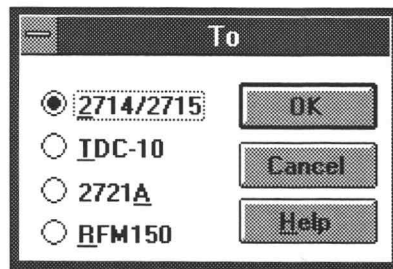

Figure C-10: The To dialog box

2. Select the option button of the instrument that you want to download the Channel Table to. The example selects the 2714/2715.
3. Choose the OK command button to download the Channel Table.
4. Repeat these steps for the other instruments so that all of the equipment has the same Channel Table.

These are the basics that you need to use the Channel Table Editor application with the CSS500 application.

## Cautions

When creating or using a channel table, follow these cautions to ensure that the software functions properly.

### Matching Channel Tables in the CSS500, Test Equipment, and the Cable System

The Channel Table used by the software must match the Channel Table in the equipment. Also, the Channel Tables used by the software and the equipment must match the cable system connected to the equipment. If any of the three do not match, measurements you take will be incorrect, errors will be returned, or the software will behave unpredictably.

The 2714 will not run digital measurements, but uses the same channel table format as the 2715. If the software attempts to take a measurement on digital channels using the 2714, measurements returned will be incorrect, errors will be returned, or the software will behave unpredictably.

### Channel Table Names

For the CSS500 measurements to execute properly, the corresponding Channel Tables in both the TDC-10 and the 271X must be identical to the Channel Table specified in the CSS500 Worksheet Header. (If they are selected as the demodulator.) If the CSS500 software finds that the Channel Table in the TDC-10 or the 271X does not match, by NAME, the channel table that the CSS500 is using, the CSS500 loads the Channel Table it is using into the TDC-10 and 271X.

This scheme allows you to easily switch to different named Channel Tables as follows:

1. Choose Worksheet Info, from the Configure menu.
2. In the Channel Table group, select a new table from the combo box.
3. Choose the OK command button to end the worksheet Info dialog. At this point a new worksheet is created. A message appears, allowing you to save the old worksheet.
4. When a measurement executes on this new worksheet, CSS500 will automatically select the new Channel Table in both the TDC-10 and the 271X. If the named Channel Table does not exist in either piece of equipment, the Channel Table loads into the instrument(s) before making the measurement.

CSS500 detects Channel Table mismatches by comparing the Channel Table name only. It does not compare the contents of the Channel Tables. Therefore, use caution when editing named Channel Tables. For instance, assume the current worksheet is using a Channel Table named MYSYSTEM.CHT and that this Table exists in both the TDC-10 and the 271X. Now suppose the Channel Table is edited, using the Channel Table Editor to add channel 78, and then saved under the same name, MYSYSTEM.CHT. Upon returning to the CSS500 worksheet, notice that the new channel is not present in the spreadsheet. Also notice that the new channel will not be present in the MYSYSTEM tables in either the TDC-10 or the 271X. So that even if a new worksheet is created, which includes the edited Channel Table, the new channel will still not be accessible in the instruments for the measurements. This is because the CSS500 compares Channel Table names and not contents.

Use the following guidelines for editing existing Channel Tables:

If an existing Channel Table is edited in any way, it is easiest to save it under a different name. Then create a new worksheet to use this Channel Table.

If an existing Channel Table must be edited and saved to the same name, perform the following steps:

1. Start with the Channel Table as the current one in the worksheet. (Its name is in the Worksheet Header.)

2. Choose Worksheet Info, from the Configure menu. The current Channel Table is already selected in the Channel Table Group combo box.
3. Choose the Create/Edit Channel Table command button to start the Channel Table Editor.
4. The Current Table is in the editing buffer of the Channel Table Editor. Edit the Table as required and then save the Channel Table, using the same name.
5. If a Channel Table using the same name currently exists in the instrument, delete it.
6. Use To, from the Transfer menu, to transfer the edited Channel Table to both the TDC-10 and the 271X.
7. Exit the Channel Table Editor and return to the CSS500 Worksheet Info dialog box.
8. Choose the Cancel button to return to the CSS500 worksheet.
9. Choose New, from the file menu, to create a new worksheet to use the "edited" Channel Table.

**Out of Bounds Limits**

The Channel Table fields have limits. If these limits are exceeded you will be able to open the Channel Table but will be given a warning that there is a problem with the file. Use the Limits Check, from the Transfer menu, to find the problems and correct them.

**Independent Operation**

The Channel Table Editor is an application that can be used independently of the CSS500. However, do not perform any Channel Table Loader operations while measurements are taking place using CSS500. Do not change or load a Channel Table while an instrument is using the table.

**Channel Table Names**

If you enter the Channel Table Editor from CSS500 via the Create/Edit Channel Table command button and you make a new Channel Table, the Channel Table list is not immediately updated in the Worksheet Info dialog box when you return to CSS500. You must close the dialog box and open it again before the new Channel Table appears in the list.

CSS500 will not make changes to the Channel Table unless you create a new worksheet. This prevents you from corrupting data on the current worksheet.

**T-Channels** The 271X's standard contains T-Channels (channels below 50 MHz) but CSS500's std.cht does not contain T-Channels. (The TDC-10 cannot handle T-Channels, so CSS500's std.cht does not have them.) Due to the way CSS500 compares Channel Tables, even if T-Channel measurements are made with the 271X they cannot be loaded into CSS500. (The std.cht would not recognize the channels and skip over the data in them.) If you want to make measurements using the T-Channels, you need to define a new Channel Table, load it into the 271X, and make the measurements using it.

**Downloading Channel Tables to a TDC-10 via RS-232**

The following are the TDC-10 settings that must be used when downloading Channel Tables from a PC to a TDC-10 via the TDC-10's RS-232 port.

Status	OnLine
Baud Rate	(Same as selected in the Connections dialog box. See page C-26)
Parity	None
Flow Control	Hard
Output Term.	CR/LF or LF
Echo Mode	Off

Use a NULL-modem cable between the PC and the TDC-10. Check your PC and TDC-10 manuals to make sure that the cabling is compatible.

**TV1350, EMFP, and Channel Tables**

You cannot download Channel Tables into the TV1350 or the EMFP. When the instrument needs a channel frequency it looks it up and then uses the "Tune to Channel" command to tune the demodulator to the required frequency. Any changes made to a Channel Table are immediately reflected in the measurements made with the TV1350 or EMFP.

**Channel Tables Provided**

Channel Tables provided with CSS500 are read-only, since they represent Channel Tables pre-loaded in the equipment (271X, TDC-10, and 2721A). This prevents you from throwing off the alignment between a worksheet Channel Table and an instrument Channel Table. The only exception is STDOFST.CHT, which is not associated with any instrument. If you must edit a Channel Table, you should rename it, being careful not to use a name from the list below. Table C-1 is a list of the standard Channel Tables provided with the Channel Table Editor.

Table C-1: Channel Tables provided with CSS500

From What Instrument	Channel Table Name	Contents/Function
TDC-10	B'CAST.CHT	North America VHF/UHF Broadcast channels
	CATV-STD.CHT	United States CATV standard channels (no T-Channels)
	CATV-HRC.CHT	United States CATV HRC (Harmonically Related carriers) channels
	CATV-IRC.CHT	United States CATV IRC (Increment-Related Carriers) channels
	EUR-BG.CHT	European system B/G UHF/VHF and CATV
	EUR-I.CHT	European system I UHF
	JAPAN-M.CHT	Japan system M UHF/UHF
	CHINA-DK.CHT	China system D/K UHF/VHF
2714/2715	STD.CHT <sup>1</sup>	United States CATV standard channels (no T-Channels, frequency limited to channel 94)
	HRC.CHT	United States CATV HRC (Harmonically Related Carriers) channels
	IRC.CHT	United States CATV IRC (Increment-Related Carriers) channels
2721A	STNDRD.CHT	United States CATV standard channels (no T-Channels, frequency limited to channel 94)
	JAPAN_M.CHT	Japan system M UHF/UHF
	EUR_BG.CHT	European system B/G UHF/VHF and CATV
	EUR_I.CHT	European system I UHF
	EUR_I1.CHT	European system I UHF
	CHIN_DK.CHT	China system D/K UHF/VHF
none	SDTOFST.CHT	United States CATV standard channels with common frequency offsets applied

<sup>1</sup> Note that the T-channels are not included in this Channel Table but they are included in the Channel Table with the same name in the 271X. This is because the TDC-10 cannot make measurements on the T-Channels. If you want to make measurements on the T-Channel using CSS500, you need to make a new Channel Table that includes the T-Channels and make the measurements using that Channel Table.

## Overview

This section goes through each of the menu commands and gives a brief description of what they are and how they work.



### Control Box

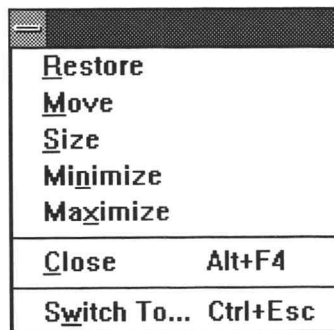

Figure C-11: The Control Box menu

**Restore.** The Restore command returns the Channel Table Editor application window to its previous size and position. It is often used to change an icon back into a window. It will also change the window between two different sizes and positions. It performs the same functions as the Restore command button (small box with both up and down arrows) on the upper right hand corner of the worksheet.

**Move.** Move allows different placements of the Channel Table Editor window. This is equivalent to clicking on the Title Bar and holding down the left mouse button to reposition the display. The Move command is only allowed if the application window is not at its maximum size.

To use Move with the keyboard:

1. Choose Move. (Press ALT+spacebar, then type m.)
2. Press the arrow keys until the window is in the desired position.
3. Press ESC to stop moving the window.

**Size.** Size allows you to change the size of the application window.

**Minimize.** The Minimize command changes the application to an icon. The application is still running but it is no longer the active window. Channel Table Editor stays in exactly the same operating state as when it was converted to an icon. This performs the same function as the Minimize button (small box with



the down arrow) on the upper right hand corner of the worksheet. (See Figure 3-1 on page 3-3.)

**Maximize.** The Maximize command changes the application from an icon back to the active window. This also changes a sized window into one that fills the entire display area. Maximize performs the same function as the Maximize command button (small box with an up arrow) on the upper right corner of the worksheet.

**Exit.** Closes the Channel Table Editor application window.

**Switch To.** The Switch To command changes from one running application to another.

### Menu Bar

The Menu Bar of the Channel Table Editor (see Figure C-12) provides access to all of the Channel Table Editor's functions.

File Edit View Transfer Help

Figure C-12: The Menu Bar

**File.** The File menu (see Figure C-13) contains the basic Windows file manipulation commands, described in the following paragraphs.



Figure C-13: The File menu

- **New.** New empties the Channel Table and gives you a blank Channel Table. New prompts for save if the current Channel Table has been modified.
- **Open.** Open loads a previously existing Channel Table. A dialog box prompts for a file. See Figure C-14.

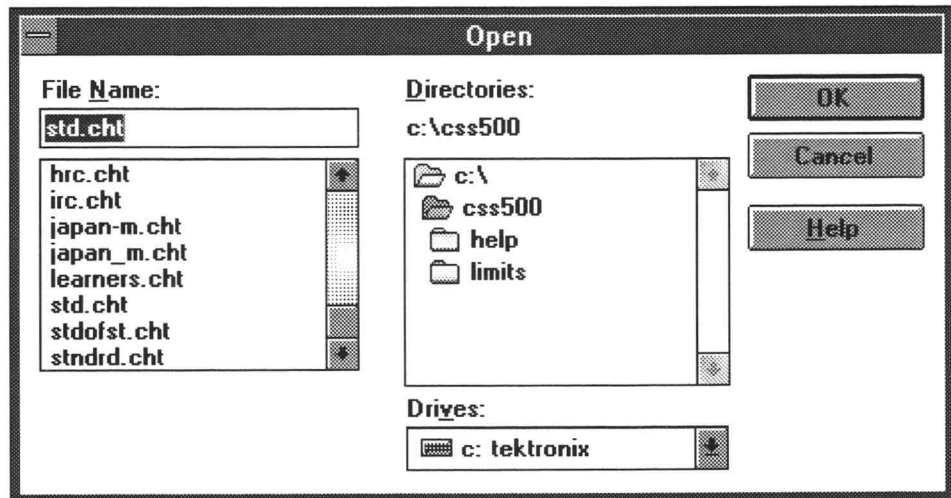

Figure C-14: The Open dialog box

- Save. Save the changes made to the Channel Table to the file specified in the main Window caption. If the Channel Table has no name, it will prompt you for one.
- Save As. Save As saves a Channel Table under a new name. See Figure C-15.

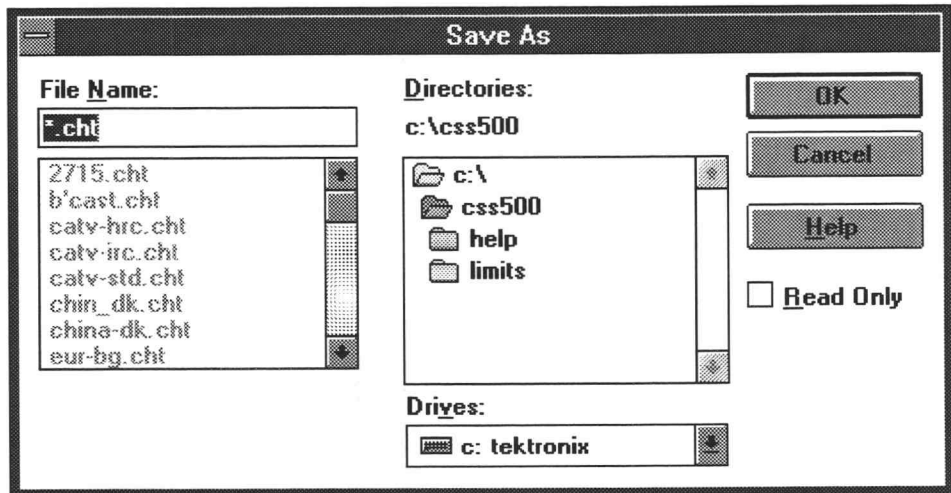

Figure C-15: The Save As dialog box

- Print. Prints out the current Channel Table. See the Windows manual for more information on this dialog box. See Figure C-16.

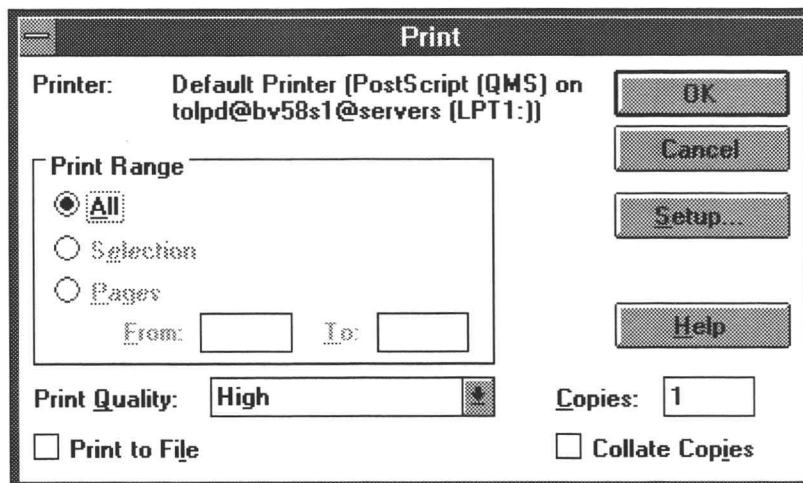

Figure C-16: The Print dialog box

- **Print Setup.** The Print Setup dialog box allows you to configure the printer as required. See Figure C-17. This is the same dialog box accessed through the Setup command button in the Print dialog box.

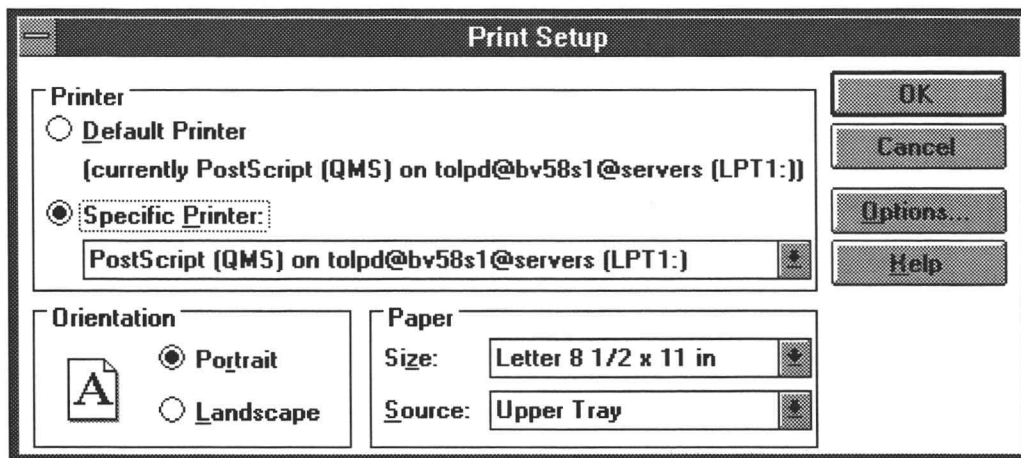

Figure C-17: The Print Setup dialog box

- **Exit.** Closes the Channel Table Editor application. Prompts for confirmation if the current Channel Table has been modified.

**Edit.** The Edit menu (see Figure C-18) contains the commands used to modify the Channel Table. They are: Insert, Delete, Append, Copy Fields to End, Edit Table Info, and Sort.

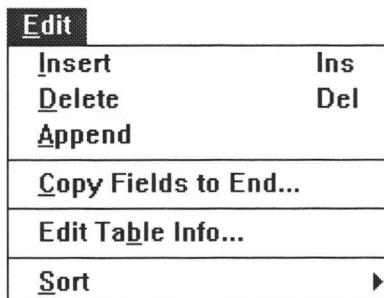

Figure C-18: The Edit menu

- Insert. The same as Insert from the Button Bar. Insert places a blank row into the Channel Table (only the default values are filled in). The channel is placed just before the selected (active) channel.
- Delete. Removes the selected channel from the Channel Table. Same as Delete from the Button Bar. This command is only available when a channel has been selected.
- Append. Functions the same as Insert, except it adds the new channel to the end of the Channel Table.
- Copy Fields to End. This command allows you to copy the selected channel fields to all of the channels below the selected one in the Channel Table. See Figure C-19. Use this command to quickly make “universal” changes. This dialog box does take the View Fields into account. If a field is not in view, then it is not listed in the Available Fields list box.

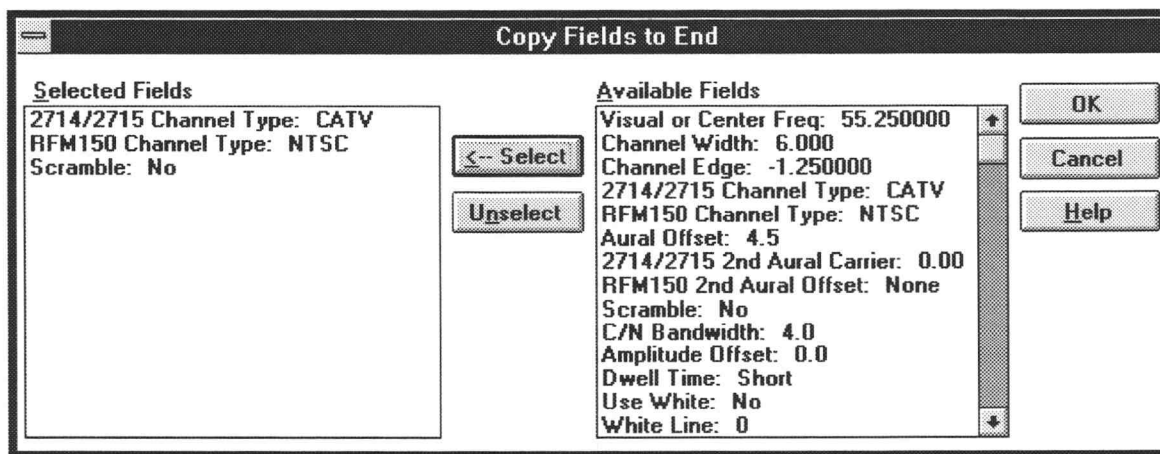

Figure C-19: The Copy Fields to End dialog box

- Edit Table Info. Edit Table Info opens the Edit Table Information dialog box filled with the information that is standard throughout the Channel Table. See Figure C-20.

The screenshot shows a dialog box titled "Edit Table Information". It contains the following fields and controls:

- Table Name:** An empty text input field.
- Number of Channels:** A text input field containing the value "200".
- 2714/2715 Aural Offset:** A text input field containing "4.500000" followed by "MHz".
- Video Standard:** A group box containing two radio buttons: "NTSC" (which is selected) and "PAL".
- TDC-10 Aural Offset:** A text input field containing "4.5" followed by "MHz" and a spin button.
- Buttons:** Three buttons are located on the right side: "OK", "Cancel", and "Help".

**Figure C-20: The Edit Table Information dialog box**

**Table Name.** The name of the Channel Table.

**Number of Channels.** The number of channels in the Channel Table. If you edit this number to increase the number of channels, blank channels are added to the end of the Channel Table. The maximum number of channels available is 500. If you decrease the number of channels, the channels are deleted beginning with the last channel in the Channel Table and working backward.

---

**NOTE.** *The maximum number of channels that the instruments can handle is 200. Therefore, you can have 200 channels marked for Include in Transfer (see page C-31) and 300 more just for switcher information.*

---

**Aural Offset.** The nominal difference between the visual and aural carriers. The 271X uses this parameter.

**Channel Width.** The width of the frequency allocation for a single channel.

**Video Standard.** Either NTSC or PAL.

**TDC-10 Aural Offset.** The nominal difference between the visual and aural carriers. The TDC-10 uses this number.

- Sort. You can sort the channel table three ways:

By Channel Number. Sorts the entire Channel Table using the channel number as the sort key.

By Frequency. Sorts the entire Channel Table by frequency.

By Program. Sorts the entire Channel Table by program.

**View.** This menu allows you to set the Channel Table Editor to display only the fields that are of current interest.

- Channel Table Fields. This dialog box allows you to view only the Channel Table Fields that are of interest to you and hide the fields that are not relevant. Figure C-21 shows the dialog box and Table C-2 lists the fields available under each choice. You can mix and match fields to match your requirements. If no fields are selected, then only the fields that are always displayed are shown.

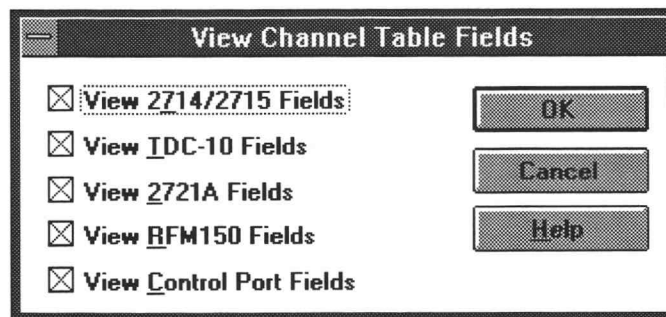

Figure C-21: The View Channel Table Fields dialog box

**Table C-2: The Channel Table fields available from each group**

	2714/ 2715	TDC-10	2721A	RFM150	Control Port	none
Channel Number	x	x	x	x	x	x
Visual Frequency	x	x	x	x	x	x
Tag	x	x	x	x	x	x
Program	x	x	x	x	x	x
Channel Edge	x			x		
RFM150 Channel Type				x		
Aural Offset			x	x		
RFM150 Second Aural Offset				x		
2714/2715 Second Aural Offset	x					
Scramble	x			x		
RFM150 Carrier/Noise Bandwidth				x		
Amplitude Offset				x		
Dwell Time				x		
2714/2715 Channel Type	x					
Use White	x					
White Line	x					
Use Quiet	x					
Quiet Line	x					
Use ICR	x					
ICR Test Line	x					
Video Polarity	x					
Sync Polarity	x					
Test Pulse Offset			x			
Offset Frequency			x			
Include in Transfer					x	
Switcher Control String					x	

**Transfer.** The Transfer menu loads the Channel Table into the test equipment and can also extract or delete Channel Tables from the instruments. The commands in the Transfer menu are shown in Figure C-22.

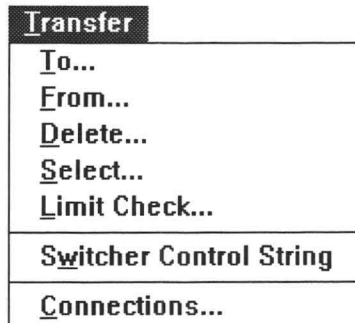

Figure C-22: The Transfer menu

- To. Takes the current Channel Table and loads it into the selected test instrument. See Figure C-23.

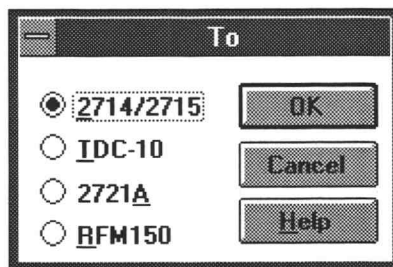

Figure C-23: The To dialog box

---

**NOTE.** *If the Channel Table is currently in use by the instrument, this command will be refused.*

---

- From. Extracts an existing Channel Table from a piece of test equipment and puts it in a format the Channel Table editor can use. It prompts for confirmation if the current Channel Table has been modified, but not saved to a file, since it will be overwritten during this operation. See Figure C-24.



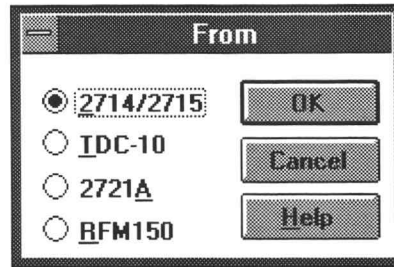

Figure C-24: The From dialog box

After an instrument has been selected, the dialog box shown in Figure C-25 appears. It lists all of the Channel Tables currently in the instrument. Select which Channel Table you want copied from the instrument, then OK. The Channel Table is then copied from the instrument to the Channel Table Editor window.

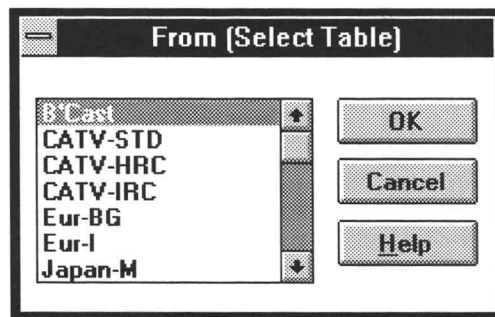

Figure C-25: The From (Select Table) dialog box

- Delete. Deletes a Channel Table from an instrument. See Figure C-26.

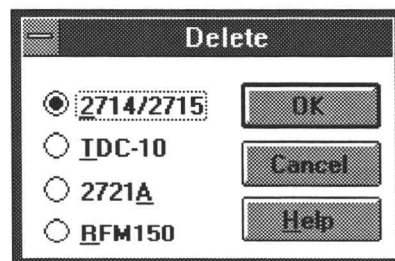

Figure C-26: The Delete dialog box

Once an instrument is selected, then the dialog box shown in Figure C-27 appears. Notice this list is different than the one in Figure C-26 for the From command. The From command list all of the Channel Tables, while the Delete command only lists user-created Channel Tables. This prevents accidentally erasing built-in Channel Tables.

---

**NOTE.** *If the Channel Table is currently in use by the instrument, this command will be refused.*

---

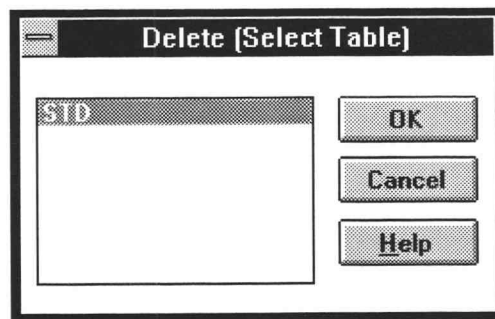

**Figure C-27:** The Delete (Select Table) dialog box

---

**NOTE.** *The 2721A will not delete a Channel Table except from its front panel.*

---

- **Select.** This command allows you to make a specific Channel Table in an instrument active. First you select the instrument from the Select dialog box. Then you are given a list of the current Channel Tables in that instrument. You select the desired Channel Table from that list.

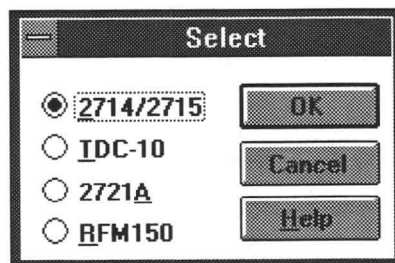

**Figure C-28:** The Select dialog box

To update a channel table that is in use:

1. Select a channel table other than the one in use.
  2. Delete the channel table you intend to update from the instrument (not from the computer).
  3. Send the updated channel table to the instrument.
  4. Select the updated channel table in the instrument.
- **Limit Check.** Limit Check checks all of the Channel Table data for compatibility with one or more instruments. If any problems are found with the Channel Table data, a message box is displayed, describing the first problem found. See Figure C-29, Figure C-30 and Figure C-31.

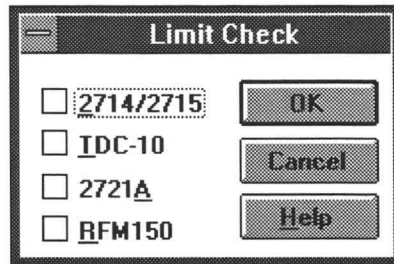
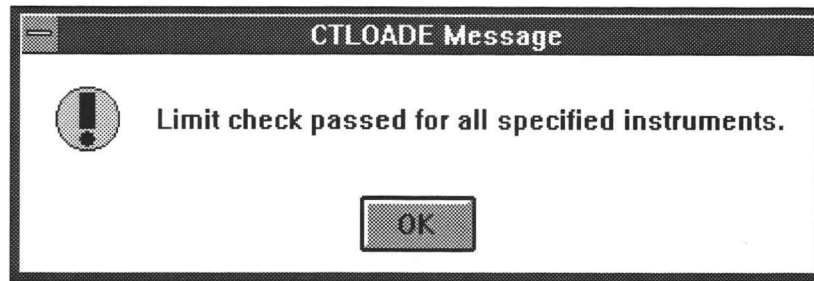

Figure C-29: The Limit Check dialog box



Figure C-30: The Message box warning that multiple channel widths are incompatible with some 2714 and 2715 instruments



**Figure C-31: Limit Check passed message**

- **Switcher Control String.** The Switcher Control String command allows you to test the command string entered in the Switcher Control String field for the selected channels. When you select this command it runs the command in the Switcher Control String field. You can then check your switcher's control panel to make sure that the appropriate switches took place.

Please see the description of the Switcher Control Field on page C-31 for more information on controlling a switcher.

- **Connections.** Use the Connections dialog box (shown in Figure C-32) to set the GPIB and RS-232 port addresses for the instruments in the Channel Table Editor. These addresses are for loading and retrieving Channel Tables in the test equipment's NVRAM and for controlling the switcher. If the switcher settings were correct in the CSS500 application they will not need to be edited here. (Any changes in this dialog box affect both applications.).



---

**CAUTION.** *Make sure that all ports and GPIB addresses are unique and match the addresses set in the instruments. The ports and addresses must be unique for both the Cable TV Software and the Channel Table Editor, because the connections menus interact. If the ports and addresses are not unique, the software will not work correctly.*

---

**Connections**

**2714/2715 Spectrum Analyzer**

GPIB GPIB Address: 0

RS-232 Baud Rate: 4800 COM Port: 1

**TDC-10 Downconverter**

GPIB GPIB Address: 2

RS-232 Baud Rate: 9600 COM Port: 1

**2721A Sweeper**

COM Port: 1

**RFM150 Signal Level Meter**

Baud Rate: 9600 COM Port: 2

**Switcher Control Port**

COM Port: 3 Baud Rate: 9600

Flow Control: NONE Parity: None

Stop Bits: 1 Data Bits: 8 Delay: 1

OK  
Cancel  
Help

Figure C-32: The Connections dialog box

**Help.** The Help menu contains access for on-line help.

- Contents. Contents displays information about Channel Table Editor, including a description of the main window.
- About. Displays the version number and copyright information. See Figure C-33.

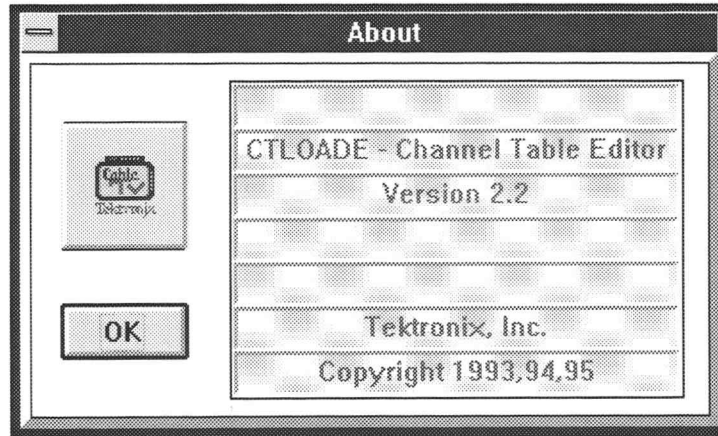

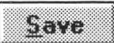







Figure C-33: The Channel Table Editor About dialog box

## Button Bar

	<b>Open</b>	Opens an existing Channel Table. Same as Open from the File menu. (See page C-15.)
	<b>Save</b>	Updates the Channel Table information. Same as Save from the File menu. (See page C-16.)
	<b>Insert</b>	The same as Insert from the Edit menu. (See page C-18.)
	<b>Delete</b>	The same as Delete from the Edit menu. (See page C-18.)
	<b>Copy Fields</b>	The same as Copy Fields to End from the Edit menu. (See page C-18.)
	<b>Edit Table Info</b>	This is the information that is the same for every channel of a Channel Table: the Aural Offset, Channel Width, and the Color System. For example, you cannot have both NTSC and PAL channels in one Channel Table. This command button is the same as double-clicking on the Table Information list box or choosing Edit Table Info, from the Edit menu. (See page C-19.)
	<b>View Fields</b>	Same as Channel Table Fields from the View menu. (See page C-20).

## Channel Table Fields

**Chan # .** The commonly known number of this channel.

**Program.** A 6-character identifier for the channel, used for the channel's call letters or abbreviated name.

**Tag.** A 3-character designation for the channel, such as "AAA" or "2 B". This is used by the 2721A. It must be uppercase alphanumeric (0-9 and A-Z, space is OK as long as there are additional valid characters).

**Visual or Center Freq.** The visual carrier frequency in MHz.

**Channel Width.** The width of the channel. In 2714 or 2715 instruments with firmware version 09.29.94 or earlier, only one channel width can be specified and it applies to all channels. To unambiguously determine a channel width when sending to one of these instruments, all channel widths must be the same. You can use the Copy Field to End command to make all channel widths the same.

**Channel Edge.** The frequency difference between the visual or center frequency and the lower bound of the frequency allocation. For example, for analog channel 2 in the USA, the Visual or Center Freq is set to 55.25 MHz, the Channel Edge is set to -1.25 MHz, and the Channel Width is set to 6.0 MHz. For digital channels, the Channel Edge should be one-half of the Channel Width. For example, a digital channel centered between 57 and 60 MHz should have the following values in the channel table: Visual or Center Freq set to 58.5 MHz, Channel Width set to 3 MHz, and Channel Edge set to -1.5 MHz.

**2714/2715 Channel Type.** The type of signals transmitted on this channel: CATV, FM, Pilot, or Digital. This field is just for the 2714/2715.

**RFM150 Channel Type.** The type of signals transmitted on this channel: NTSC, PAL, SECAM, or Digital. This field is just for the RFM-150.

**Aural Offset.** The nominal difference between the visual and aural carriers. This is a single channel aural offset.

**2714/2715 Second Aural.** The offset between the visual carrier and the second aural carriers. This value must be at least 200 kHz above the first aural carrier

and below the channel edge. Only used by the 2715 and firmware version 1.12.94 and later of the 2714.

**RFM150 Second Aural Offset.** The nominal difference between the visual and aural carriers. This is the second channel aural offset. Only used by the RFM-150.

**Scramble.** Whether or not this channel is scrambled.

**RFM150 CN BW.** The RFM150 Carrier-to-Noise bandwidth. This is the bandwidth used to compute the Carrier to Noise calculations. Only used by the RFM-150.

**Amplitude Offset.** The offset applied to the Visual Carrier Level readings on this channel.

**Dwell Time.** The amount of time that should be spent gathering data. Video format determines the dwell time.

**Use White.** Selects whether the white line or the whole field should be used in the amplitude measurements.

**White Line.** The location of the white line.

**Use Quiet.** Selects whether the quiet line or the whole field should be used in the Carrier to Noise and CSO measurements. If Use Quiet Line is NO, then the instrument will auto search for unmodulated lines on which to make Carrier to Noise and CSO measurements. If Use Quiet Line is YES, then the instrument will use the line number supplied in the Quiet Line field (below). (2715 only.)

**Quiet Line.** The quiet line in the video signal used for making the Carrier to Noise and CSO measurements. It must be between 4 and 1023 (4 is the lower limit for PAL and 7 is the lower limit for NTSC). (2715 only.)

**Use ICR.** The ICR measurement should be made using the specified test line. If Use ICR is NO, then this measurement is skipped. If you attempt to make a measurement on a channel with Use ICR set to NO, the instrument will try to execute the measurement, but color the results cell blue to indicate that there was a problem with the measurement. (2715 only.)

**ICR Test Line.** The location of the ICR test line in the video signal. This line number is placed in the Notes field for the measurement results. The test line can be either multiburst or Philips ghost canceling signal. You can change the ICR



**Test Line** from the 2715's front panel and the value will be stored in the instrument's Channel Table. (2715 only.)

**Video Polarity.** Polarity of the video signal.

**Sync Polarity.** Polarity of the sync pulse.

**Test Pulse Offset.** The frequency offset applied to the test pulses from the 2721A in MHz. (Used by the 2721A only.)

**Offset Frequency.** Indicates whether the indicated visual carrier frequency is at, above, or below the nominal visual carrier level.

**Include in Xfer.** Include in Transfer. If this field is marked yes, then the channel information is transferred to the RF instrument during a Channel Table load. All measurements are available. If this field is marked no, then this channel is not loaded in the RF instrument and the RF measurements are not available from the CSS500. These cells are grayed out as shown in Figure C-34. (Channel 2 was not included in transfer. Notice the number of grayed cells.)

	Vis Car Lev	Vis Car Freq	Aur Car Lev	Aur Car Freq	2nd Aur Lev	2nd Aur Freq	Avg Pwr	C / N	D / U	C S O	C T B	X Mod	A C L	I C R	H U M	FCC BB	Mod Dep	Aur Dev	S / N	Wfm Dis
2		*									*						*			
3																				
4																				

Figure C-34: The Global View from the CSS500 application

**Switcher Control String.** This string is used to control a connected switcher, with a maximum of 110 characters. If there are any commands in this string, they are executed prior to CSS500 making any measurements. CSS500 supports Pesa and Grass Valley Group switchers (and others). Both switchers require slightly different control strings.

The key to the switcher string is that a backslash and the next two numbers are always the ASCII character values in hex. For example: \02 is control B

(important for the GVG switcher), \27 is Escape (important for the Pesa), and \13 is Return or Enter. All characters can be entered as ASCII strings if desired.

Another important code is \FF. This is the Pause Delimiter. Whenever this code is encountered the switcher pauses for the amount of time set in the Connections dialog box (see page C-26).

- GVG Switcher Control. For a GVG switcher, a typical command string looks like:

```
\020094
```

\02 is control B, telling the switcher to switch. It must be this value.

00 is the address of the switcher. It is always 2 bytes.

9 is the video switch. It is always one byte.

4 is the audio switch. It is always one byte.

- Pesa Switcher Control. When sending controls to a Pesa, remember that you are emulating a terminal and that you are working blind. Because the Pesa switcher uses a hierarchical menu scheme, the typical Pesa string is more complex. For a Pesa switcher, the typical string looks like:

```
\27N\27N\27N\27N\27N\27N\27N\27N\27N\27N\27N\27N\27Y\13B\133\134\13
```

\27N is Escape and No. The long string of \27N is to guarantee that you are at the top of the menu hierarchy before you begin to give commands. When writing your own strings, you should use at least 15 of these to avoid problems.

\27Y tells the switcher that you are ready to start.

---

**NOTE.** *Although it is not shown here, a user name and password could be entered here because you are at the initial login screen. This is not always necessary; it depends on how your particular switcher is set up.*

---

\13 is an ASCII return.

B is the command for switch.

\13 is an ASCII return to accept the switch command.

3 tells the switch the destination line, this case it is line 3. (This could be any number.)

\13 accepts the destination line

4 tells the switcher the source line; in this case it is line 4. (This could be any number.)

\13 accepts the line and the switch is complete.



## Appendix D: FCC Measurements

---

**NOTE.** *The methods given in this chapter are just suggestions. It is the operator's responsibility to comply with FCC requirements.*

---

This chapter discusses how to perform FCC Headend and Field measurements. Most of the information is not applicable outside of the United States. Use it as a starting point to help you define your own procedures to meet FCC Measurement requirements. This chapter assumes you are familiar with the following concepts:

- Configuring Worksheets
- Defining Measurement Sequences
- Generating 2714/2715 UDPs
- Getting 2714/2715 Stored Results
- Importing/Exporting Measurement Results
- Viewing Results
- Using the Clipboard

### Organizing Worksheets and Measurement Results

The FCC testing requirements result in large numbers of measurement results, even for modest systems. Organizing these results in a reasonable way allows for quick access to the results for verification, analysis, and reporting. The directory structure shown in Figure D-1 is a good example of how to organize FCC performance test results. The remainder of this chapter describes how to create this structure, fill it with test results, and access the results for verification, analysis, and reporting.

For example, create the directory structure shown in Figure D-1, using the Windows File Manager. You can place this directory tree anywhere, but not in your LIMITS directory for CSS500. It is good practice not to put anything in the Limits directory except Limits files.

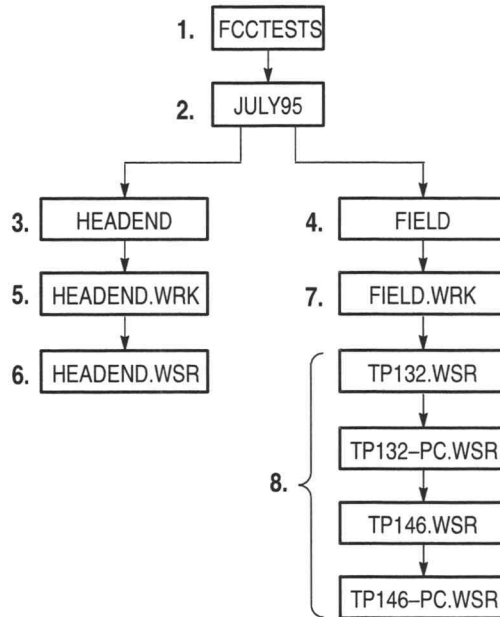

**Figure D-1: Organization of files for logical record keeping**

1. FCCTESTS is a directory that contains all of the FCC type measurement results.

Group each test session by the month and year performed. A test session is defined as all the FCC required twice-yearly performance tests for a particular system.

2. JULY95 is a sub-directory of the FCCTESTS directory that contains all of the measurement results for July of 1995.

Group the performance tests by those required at the Headend (output of modulating or processing equipment) and those required at the field test sites (for example, subscribers' terminals).

3. HEADEND is a sub-directory of JULY95 that contains the results of the Headend measurements for that month. (Notice that there are no files above this level – only directories.)
4. FIELD is a sub-directory of JULY95 that contains all of the field measurements made that month. (Again, notice that there are no files above this level – only directories.)
5. HEADEND.WRK is the worksheet used to define, control, and collect results for this Headend test session.
6. HEADEND.WSR contains the actual results from this Headend test session.

7. FIELD.WRK is the worksheet used to define, control, and collect results for this field test session.
8. The rest of the files are the actual measurement results from the TP132 and TP146 test Sites (Test IDs) collected during this session.

## FCC Headend Measurements

The FCC Headend measurement requirements consist of a series of RF and baseband measurements taken on a set of channels at the Headend.

The following describes how to use a Measurement Sequence to perform all the required Headend measurements and how to collect and present the measurement results.

### Configure a New Worksheet

Configure a new worksheet to match the system and testing methods.

1. Choose New, from the File menu.
  - Set the Channel Table and Site name to match the system. For example, use STD.CHT for Channel Table and Headend name for Site.
2. Set up the worksheet items listed below from the Configure menu:
  - Test ID – Set to a test session identifier or operator name such as “Headend Test 7-16-1995”.
  - Preferences – Measurement History is not required for this example, so set it to Keep Last Result Only.
  - Measurement Limits
  - Measurement Setups

### Define the Measurement Sequence

Define the Measurement Sequence used to execute the required measurements.

1. Choose Measurement Sequence from the Configure menu.
2. Define the measurements by choosing the FCC Headend Msmts command button. This provides a method to easily select the required measurements. Carrier Levels and Frequencies are automatically selected for all channels.
3. Select specific test channels for the FCC Baseband measurements (which includes chroma-luma delay, chroma-luma gain, differential gain, and differential phase) using the Select command button. These are the system-specific test channels chosen to comply with the FCC regulations on number of test channels based on system frequency limit.

4. Select the OK button when the selected test channel list is correct. The Measurement Sequence dialog box displays the selected FCC Headend measurements.
5. Define the Measurement Sequence execution time parameters by choosing the Edit Time Parameters command button.
6. Set it up to run immediately, 1 time.
7. Select OK to return to the Measurement Sequence dialog.
8. Select OK to return to the worksheet.
9. Execute the Measurement Sequence using the Exec Seq command button on the Button Bar, or Measurement Sequence, from the Measure menu.

The Measurement Sequence executes the FCC Headend measurements.

10. When the sequence is complete, answer Yes to turn on the Measurement Sequence View filter. The worksheet displays only the results from the Measurement Sequence just completed (that is, the FCC Headend performance tests).

**Summarize the  
Measurement Sequence  
Results**

1. Choose Global View, from the View menu, to look for measurement cautions and/or alarms.
2. Display a Status Report by selecting all of the cells in the Global View and choose the Results Detail command button.
3. If you wish, print the report using the Print button.
4. Choose Close to leave the Status Report.
5. Choose Close to leave the Global View.
6. Choose Export, from the File menu, to save the measurement results to a results file for archiving and importing to other report tools.
  - a. In the directory list box select: FCCTESTS/JULY95/HEADEND.
  - b. In the File Name, enter HEADEND.WSR.
  - c. Choose OK to export the results.
7. Optionally, use Select All and then Copy, from the Edit menu, to copy the results to the Clipboard for transfer to other tools, (for example, MS-Excel, or MS-Word). Once the results are exported or copied, use other data analysis tools (such as MS Excel) to generate complete FCC Proof Reports.



**Save the Worksheet** Use Save As, from the File menu, to save the worksheet for future reference.

1. Choose Save As from the File menu.
2. In the directory list box, select FCCTESTS/JULY95/HEADEND.
3. In the File Name box, enter HEADEND.WRK.
4. Select OK to save the worksheet.

## FCC Field Measurements

The FCC field measurement requirements consist of a series of, primarily, RF measurements taken on a channel set at various points in the system. Since the 2714/2715 Spectrum Analyzer can make all of the required measurements, the following describes how to define and use 2714/2715 User Defined Programs (UDPs from Measurement Sequences) to perform the field measurements and how to collect and present the measurement results.

FCC field testing uses three separate UDPs: one for the pre-converter performance tests, one for the post-converter performance tests, and one for the visual carrier 24-hour variation and 30M Carrier Level Performance Test.

---

**NOTE.** *The CMP/CSS500 package is transportable to field test sites for collection of performance test results at RF and Baseband using a Measurement Sequence. This is a direct extension of the procedures explained in previous chapters and further discussion is not included.*

---

Use the three UDPs at each of the required test Sites. Note that since the measurement setup parameters (for example, external attenuation/amplification) are loaded into the UDPs, these parameters are set the same for each test Site. If each Site needs different parameters, create separate UDPs for each test Site. For example, the external attenuation/amplification setup defines the test point loss for the Carrier to Noise measurements. The FCC requires levels measured at the subscriber terminals and at the end of cable drops (locations with 0 dB offset).

Using the UDP measurement method described, remove the 2714/2715 from the CMP/CSS500 package and take it to the various test Sites for measurement execution and storage of results (in the 2714/2715 NVRAM). Later, reconnect the 2714/2715 to the CMP/CSS500 package for results collection and presentation.

**Define the FCC Field  
Measurements  
Post-Converter Worksheet**

Configure a new worksheet to match the system and testing methods used for the FCC Post-Converter measurements. Use File/New and set up the worksheet items listed below.

1. In the Worksheet Info dialog box, select the Post-Converter Channel Table, STD\_PC.CHT, in the Worksheet Info dialog.

---

**NOTE.** *Measurements taken at the output of the converter require a Channel Table that retains the channel identifier (that is, channel number) but has the visual carrier frequency for each channel set to the output visual carrier of the converter. The procedures below assume that the STD.CHT Channel Table is the primary table and the post-converter table exists as STD\_PC.CHT (Standard Table, Post-Converter). You must create STD\_PC.CHT to fit your own needs.*

*Define the Site name later from the 2714/2715 front panel at each test Site.*

---

2. In the Preferences dialog box, the Pause on New Channel preference can be used to allow manual tuning of the set top converter for each new test channel.
3. Use the Measurement Setups dialog box to specify whatever is required for your system and test methods.

---

**NOTE.** *This worksheet is only used to define the FCC Post-Converter UDP and will not be saved (it is not necessary to save the file to create the UDP). Therefore, it is not necessary to define measurement limits at this time.*

---

**Define the Post-Converter  
UDP**

1. Set the Test ID for the worksheet to “FCC Post-Converter” using the Test ID button on the Button Bar or the Test ID selection from the Configure menu.
2. Choose Measurement Sequence, from the Configure menu.
3. Define the measurements by selecting the FCC Post-Converter button.
  - a. Carrier Levels and Frequencies are automatically selected for all channels.
  - b. Select the specific test channels in the Select Channels group using the Select command button. These are the system specific test channels chosen to comply with the FCC regulations on number of test channels based on system frequency limit. Select the channels that require these additional measurements:
    - Carrier to Noise
    - CTB

- CSO
  - Cross-Modulation (coherent disturbances)
  - Hum
- c. Select the OK button when the selected test channel list is complete. The Measurement Sequence dialog box displays the selected FCC Post-Converter measurements.
4. Define the Measurement Sequence execution time parameters by selecting the Edit Time Parameters command button.
    - a. Set to run immediately, 1 time.
    - b. Select OK to return to the Measurement Sequence dialog.
  5. Create a 2714/2715 UDP from the current Worksheet and Measurement Sequence setup using the Create 2714/2715 UDP button.
    - a. Enter FCC Post-Converter for the UDP title and select OK.
    - b. The UDP is created and loaded into the 2714/2715.
    - c. Verify that the selected Channel Table (STD\_PC.CHT) exists in the 2714/2715. This is not done automatically at UDP generation time — it must be explicitly done using the Channel Table Loader (see Appendix C).
    - d. Select OK to return to the Worksheet.

### Define the Pre-Converter Worksheet

Use New, from the File menu, to select the STD.CHT Channel Table. This will result in a new worksheet being created (the worksheet used to define the FCC Post-Converter UDP was only necessary for that task and does not need to be saved). Configure the items listed below for the new worksheet to match the system and testing methods:

1. Create a new worksheet by selecting New from the File menu.
2. In the Worksheet Info dialog box, select the Pre-Converter Channel Table, STD\_PC.CHT, in the Worksheet Info dialog.
3. Define the measurements from the Measurement Sequence dialog box by selecting the FCC Pre-Converter button.
4. Set preferences as required in the Preferences dialog box. (For example, select “Pause on New Channel” if an external preselector is used. This allows for manual tuning of the preselector for each channel.)

5. Specify the Measurement Limits. Limits are not formally part of the generated UDP but are defined here to support importing the measurement results.
6. Specify the Measurement Setups (select Edit Setups from the measurement Setups dialog box). Verify that the required test channels have In-Channel Response set to RF measurement method.

---

**NOTE.** Define the Site name later from the 2714/2715 front panel at each test Site.

---

### Define the Pre-Converter UDP

1. Set the Test ID for the worksheet to FCC Pre-Converter using the Test ID button on the button bar or Test ID selection, from the Configure menu.
2. Select Measurement Sequence from the Configure menu.
3. Select the Clear Sequence command button.
4. Define the measurements by selecting the FCC Pre-Converter button. This selection provides an easy method to select the required measurements:
  - a. Carrier Levels and Frequencies are automatically selected for all channels.
  - b. The FCC Amplitude Characteristic measurement is selected for all the test channels in the Selected Channels list box. This measurement can be made at RF or at baseband. Hence, an Amplitude Characteristic selection group is displayed. Since we are setting up a UDP, select In-Channel Response. (Verify that the In-Channel Response measurement setup is RF for each of the required test channels.)
5. Select the specific test channels in the Select Channels group using the Select button. These are the system specific test channels chosen to comply with the FCC regulations on number of test channels based on system frequency limit.
6. Choose the OK button when the selected test channel list is correct. The Measurement Sequence dialog box now displays the selected FCC Pre-Converter measurements.
7. Define the Measurement Sequence execution time parameters by selecting the Edit Time Parameters command button. Set to run immediately, 1 time.
8. Select OK to return to the Measurement Sequence dialog.

9. Create a 2714/2715 UDP from the current Worksheet and Measurement Sequence setup using the Create 2714/2715 UDP button.
  - a. Enter “FCC Pre-Converter” for the UDP title and select OK. This creates the 2714/2715 UDP and loads it into the 2714/2715.
  - b. Verify that the selected Channel Table (STD) exists in the 2714/2715. This is not done automatically at UDP generation time — it must be explicitly done using the Channel Table Loader (see Appendix C).
  - c. Select OK to return to the Worksheet.

### Define the UDP for Visual Carrier Level and Level Variation (30M) Measurements

Define the Measurement Sequence for the visual carrier level and level variation (30M cable) measurement.

1. Set the Test ID for the worksheet to “FCC Visual Level/Var (30M)” using the Test ID button on the Button Bar or the Test ID item, from the Configure menu.
2. Optionally, if any measurement setups or preferences need changing (based on system test methods), enter the new parameters using Measurement Setups and Preferences, from the Configure menu. For example, the Pause for New Channel preference may have been selected for the pre-converter measurements (assuming the use of an external preselector). Now, for the visual level and level variation measurements, you are not likely to want to pause on each new channel.
3. Choose Measurement Sequence, from the Configure menu.
4. Choose the Clear Sequence command button.
5. Define the measurements by choosing the 24 Hour Test command button. This selection provides easy selection of the required measurements. (Carrier Levels and Frequencies are selected for all channels)
6. Define the Measurement Sequence execution time parameters by selecting the Edit Time Parameters command button.
7. Verify that Run Immediately, Run 4 Times, and Repeat Interval = 6 Hours are selected. These parameters are set automatically when using the 24 Hour Test button.
8. Select OK to return to the Measurement Sequence dialog.
9. Create a 2714/2715 UDP from the current Worksheet and Measurement Sequence setup using the Create 2714/2715 UDP command button.
  - a. Enter “FCC Visual Level/Var (30M)” for the UDP title and select OK. This creates the UDP and loads it into the 2714/2715.

- b. Verify that the selected Channel Table (STD) is loaded in the 2714/2715. This is not done automatically at UDP generation time — it must be explicitly done using the Channel Table Loader (see Appendix C).
  - c. Select OK to return to the Worksheet.
- 10. Use Save As, from the File menu, to save the worksheet for future reference.
  - a. In the directory list box select FCCTESTS/JUL95/FIELD
  - b. In the File Name box enter FIELD.WRK.
  - c. Select OK to save the worksheet.

### Execute the UDPs at Each Test Site

Once the UDPs are defined and loaded, the 2714/2715 can be removed from the CMP/CSS500 package and taken independently to each test Site for measurement execution and results collection. (Remember to load the correct Channel Tables into the 2714/2715.)

The 2714/2715 has limited on-board results storage capacity. Therefore, it may be desirable to remove all currently stored measurement results before executing the UDP at the first test Site. See the 2714/2715 manual for more information on its measurement storage capacity. Also, in order to provide more on-board storage capacity, remove additional items such as stored settings and waveforms, unused Channel Tables, etc., from the 2714/2715 NVRAM. See the 2714/2715 user manual for specifics on these operations.

1. At each test Site, first enter the Site name into the 2714/2715 using the 2714/2715's front panel keys (see the 2714/2715 user manual for specifics on this operation). This allows tagging each measurement result with the correct measurement Site. Use these Site name tags to encapsulate measurement results by individual Sites. For this example, we are collecting results at only two test Sites (TP132 and TP146). The FCC requires a minimum of six test Sites; for explanation purposes we are only using two. Enter Site name "TP132" before starting any UDPs at the first Site, and "TP146" at the second Site.
2. After entering the Site name, execute each UDP, by selecting the UDP name in the 2714/2715 USER DEF menu. The 2714/2715 will sequence through the measurements and store the results. (The UDP automatically stores all measurement results in the 2714/2715 NVRAM.) Depending on the chosen preferences and measurement setups, the 2714/2715 may present various prompts for user action during the execution of the UDP.
3. Repeat step 2 for the second test Site. Remember to enter the new Site name in the 2714/2715.

### Collecting and Presenting Measurement Results

1. When finished collecting data at the test Sites, re-connect the 2714/2715 to the CMP/CSS500 package.
2. Open the Worksheet used to create the FCC field test UDPs using Open, from the File menu.
  - a. In the directory list box, select FCCTESTS/JUL95/FIELD.
  - b. In the File Name box, enter FIELD.WRK.
  - c. Select OK to open the worksheet. Check that the Channel Table is STD.CHT. If it is not, select that Channel Table before continuing. Also, for the importing of results, as described below, enable Measurement History. Select the Collect History button in the Measurement History group of the Preferences dialog box, from the Configure menu.

**Retrieve the Stored Results** Use the following procedure to retrieve stored results:

1. Retrieve the stored FCC field test results from 2714/2715 using Get Stored Results from 2714/2715, from the Measure menu.
2. The CSS500 software will retrieve all measurement results from the 2714/2715 and present a directory of results grouped by Site name and Channel Table name. The listed Sites should match the two test Sites (TP132 and TP146) and the Channel Table names should match the system (STD and STD\_PC.CHT for this example).
3. Use the Export button to save each group of results into separate results files, as shown in Table D-1, for later importing into the worksheet or other programs.

**Table D-1: How the results are exported from the 2714/2715**

Site	Channel Table	Results File
TP132	STD	TP132.WSR <sup>1</sup>
TP132	STD_PC	TP132_PC.WSR <sup>2</sup>
TP146	STD	TP146.WSR <sup>3</sup>
TP146	STD_PC	TP145_PC.WSR <sup>4</sup>

<sup>1</sup> FCC Pre-Converter and Visual Level/Var (30M) results for TP132.

<sup>2</sup> FCC Post-Converter results for TP132.

<sup>3</sup> FCC Pre-Converter and Visual Level/Var (30M) results for TP146.

<sup>4</sup> FCC Post-Converter results fro TP146.

Export the results groups as follows:

- a. From the directory list box, select FCCTESTS/JUL95/FIELD.
  - b. In the File Name box, enter the Results File names as shown in Table D-1 for each results group.
  - c. Note that the Import button can be used to load results into the worksheet after the results have been exported to a results file. (Import, from the File menu, can be used the same way.)
    - Worksheets always contain results for a single Site and single Channel Table. This effectively encapsulates the results into the particular measurements taken at a particular Site.
    - Grouping of results on a per Site basis implies that results from several Sites must be imported and summarized individually on a Site by Site basis.
  - d. For this example, we will use the File/Import menu item to load, analyze, and report the measurement results. Select Close to return to the worksheet.
4. Now that the FCC field test results have been retrieved from the 2714/2715 and stored into results files, we have all the measurement results analysis and summarization capabilities of the CSS500 at our disposal. First, import the results from TP132 using File/Import.
- a. Choose Import, from the File menu.
  - b. From the directory list box, select FCCTESTS/JUL95/FIELD.
  - c. In the File Name box, enter TP132.WSR.
  - d. Select OK to import the results.
    - We want to make the worksheet Site name match the Site name of the results we are importing. Therefore, select Yes when prompted about changing worksheet Site to match import Site. (This prompt will appear only if the worksheet Site does not match the Site of the results being imported.)
    - The 2714/2715 stores only the channel number as a channel ID. The CSS500 stores Channel Number, Letter (Tag), Program Name, and Nominal Visual Carrier Frequency. Therefore, a channel mismatch message is displayed. Select the "Use blank channel information as wildcards" option button in the Import Channel Criteria group. This will allow importing of all appropriate results without further prompts. Select the Use Channel Results button to continue.



- e. The results from TP132.WSR are loaded into the worksheet. These are the FCC Pre-Converter and FCC Visual Level/Var (30M) results. To import the FCC Post-Converter results, repeat steps 4, a-d above using File Name TP132\_PC.WSR. Note that the Site name override prompts are not presented since the Site name is the same as the results previously imported.
- f. Answer Yes to the prompt about Channel Table name mismatch. We want to import the results regardless of whether they were generated with std.cht or std-pc.cht.

---

**NOTE.** *The FCC Post-Converter results were generated using the special post-converter Channel Table as described above. Here we are importing those results into a worksheet that uses the normal STD Channel Table. This is acceptable because the 2714/2715 stores only the channel number as the channel identifier and therefore all the results are placed into the correct spreadsheet cells without conflict. However, since the "Post-Converter" Channel Table we used had all the visual carrier frequencies set to a single value, the counted visual carrier frequencies for the FCC Post-Converter results will reflect that one single channel frequency value and will not match the STD Channel Table values. This will result in alarm status for the visual carrier frequency results for the Post-Converter measurements. Therefore, a worksheet status report done without any Test ID Results view filter in place will result in unwarranted alarms for the visual carrier frequency results. The remainder of the procedure describes how to use the Test ID Results view filter to prevent this situation.*

---

5. At this point, all the measurement results for Site TP132 have been loaded into the worksheet. Remember that each set of results (as generated by the FCC Pre-Converter, FCC Post-Converter, and FCC Visual Level/Var (30M) UDPs) has been tagged with a different Test ID. The results from each UDP can be viewed separately using the View/Test ID Results menu item.
6. Select FCC Pre-Converter for the worksheet Test ID.
7. Use View/Test ID Results to enable the Test ID Results view filter.
8. The displayed results are now only those generated from the FCC Pre-Converter UDP at test Site TP132.
9. The Global View (from the View menu) can be used to pinpoint trouble channels. The Status Report and Results Detail screens can be used to further analyze data. Copy, from the Edit menu, and Export, from the File menu, can be used to transfer data or results files to other analysis tools.
10. Once the results are copied or exported, other data analysis tools (such as MS Excel or MS Word) can be used to generate complete FCC Proof Reports.

11. Steps 3 through 10 can be repeated as needed for each set of results.

Results from other test Sites can be imported and analyzed using the same procedure.

## Appendix E: CSS500 Files

This appendix covers the following topics:

- Approximate file sizes
- Naming conventions
- Starting CSS500 with special worksheets
- Adding information to the Help files
- Using worksheets from older versions of the CSS500
- Using CSS500 and CSS150 together
- How to archive worksheets
- The CSS500.INI file

### Approximate File Sizes

Table E-1 lists the approximate file sizes of the different CSS500 files.

**Table E-1: CSS500 files and their approximate sizes**

File Type	Contents	Size (in bytes)
Worksheet (*.wrk)	One measurement for each of the 20 measurement types for 200 channels.	364 K
Channel Table (*.cht)	200 channels (no Switcher Strings).	55 K
Limits (*.lim)	All measurements have Caution and Alarms values. Where appropriate, they are for Upper, Lower, or both Limit values.	1.4 K

The maximum allowable worksheet size is approximately 2 MB. Note that the amount of other information contained in the worksheet, such as measurement notes or large worksheet descriptions, reduces the number of possible measurements.

## File Naming Conventions

CSS500 has very few restrictions on its file names. However, there are defaults, and it is good practice to use them to avoid confusion. All worksheets should end in “.wrk” and all exported data results should end in “.wsr”. Table E-2 gives the general conventions.

**Table E-2: Types of files associated with CSS500 and their naming conventions**

Type of File	Naming Conventions
Worksheet	*.wrk
Exported Results File	*.wsr
Limits File	*.lim
Channel Table File	*.cht

## User Aids

There are a few methods that you can use to make using CSS500 quicker and easier for your application.

### Start CSS500 with a Specific Worksheet

You can have CSS500 start with a worksheet already loaded. This is ideal if you like to start each session with a new worksheet to keep the measurements separate. The problem is that many of your channels have special Limits files assigned to them and different Measurement Setups. You don't want to take the time to remember which ones they are and set them. Make a “template” worksheet that defines all these things and then automatically load it every time CSS500 runs.

Do this from the Windows Run line or using the icons.

First, create the template.wrk worksheet.

From Run Line:

1. Choose Run, from the File menu in the Windows Program Manager.
2. Type “CSS500.EXE template.wrk” in the text box, where “template.wrk” is the name of the worksheet that you want to load.

From Windows Icon:

1. From the Windows Program Manager, select the CSS500 icon.
2. Choose Properties, from the File menu.

3. On the Command Line, after CSS500.EXE, type: "template.wrk".
4. Choose OK.

The next time you start CSS500 from that icon, your template worksheet, "template.wrk", will automatically load and be ready to run. (Make sure that you save it under a new file name right away to avoid changing template.wrk unexpectedly.) You could define several CSS500 icons, each one with a different template ready to go for the different uses. For example, you can have one for getting stored results from the 271X and one for local data gathering.

### Adding Information to the Help Files

The help files are completely editable using a basic text editor. (They were created using Notebook from Windows.) The only restriction is that only 80 characters per line are allowed.

There are several reasons why you might want to edit the help files, for example:

- To put a check list in the UDP help text to make sure that all of the appropriate preferences are set before the UDP is generated.
- To put reminders of which channels need to have special Limits files attached to them in the Limits file dialog box.

There are also help topics at the end of Contents in the Help menu for you to fill in with your own information. These are the help files for the measurements. They are there for you to note how the tests are to be performed, how often, what time of day, and so forth—whatever you might need to put in these files. The help topics and the files that you need to edit for each topic are listed in Table E-3.

**Table E-3: Help topics and their associated files**

Help Topics	File to Edit
Carrier Levels and Frequencies	levfreq.hlp
CSO	cso.hlp
CTB	ctb.hlp
Cross Modulation	crossmod.hlp
Carrier to Noise	carnoise.hlp
FCC Baseband	fccbase.hlp
Hum/LFD	hum.hlp
ICPM	icpm.hlp
In Channel Response	icr.hlp
Modulation Depth	moddepth.hlp
Multiburst	multibur.hlp

**Table E-3: Help topics and their associated files (Cont.)**

Help Topics	File to Edit
Signal to Noise	signoise.hlp
Waveform distortions	wfmdist.hlp
Aural deviation	aurdev.hlp
Audio	audio.hlp

**The MSMTSTUB.DLL File**

Sometimes you may want to use CSS500 for demonstrations or training without any equipment installed. It would also be nice if some results (even if they are meaningless) were generated. CSS500 has a “dummy” MSMT.DLL file available that will generate somewhat random numbers for results. That file is called MSMTSTUB.DLL. To use it, delete the current MSMT.DLL file and make a copy of MSMTSTUB.DLL called MSMT.DLL. When you are ready to use instruments again, delete MSMT.DLL and make a copy of MSMTREAL.DLL called MSMT.DLL.

---

**NOTE.** *You cannot make any measurements using instruments as long as MSMTSTUB.DLL is being used as the MSMT.DLL file.*

---

**Using Worksheets Created with Older CSS500 Versions**

You can use worksheets created with older versions of CSS500. Once the newer version uses them, the old version will no longer be able to recognize them. (They are not downward compatible.)

If you want data collected from an older version of CSS500 and data collected with the new version in the same worksheet, the safest route would be to use Export and Import.

1. Open the old data worksheet.
2. Export the desired data to a .wsr file.
3. Close the old worksheet.
4. Open the new worksheet.
5. Import the data (currently in a .wsr file).

**Using CSS500 and CSS150 Together**

CSS500 and CSS150 are used separately. The software must be put into separate directories. The only thing that CSS500 and CSS150 can and should share is the Channel Table files. If you want the two applications to share Channel Table files, move them out of the application directories and into a separate directory. Then the two applications can share the same files without confusion.

## How to Archive a Worksheet

There are times when you want to save a worksheet someplace other than where you have been working with it, either for archiving purposes or to send the results or setups to someone else.

For example: an MSO (Multiple System Operator) may want to define particular Limits files and Measurement Sequences for the individual operators to use. There could be one worksheet for the Pre-converter Measurements, one for the Post-converter measurement, and another for 24 Hour Variation. These could be the “master worksheets” so that the individual operators don’t have to waste time creating them. Also, when the results return to the MSO, the data will drop right into their worksheet for evaluation.

### Which Files to Save

To properly archive a worksheet, you must save several files. The following is a list of files required to properly save and then completely reconstruct a worksheet.

**The Worksheet File.** It should end in “.wrk”. It is the name in the Worksheet entry in the Worksheet Header.

**The Channel Table File.** It should end in “.cht”. Find the name in the Channel Table entry in the Worksheet Header.

**All Attached Limits Files.** Find them in the sub-directory “limits” under the directory that contains the CSS500.EXE file. You can find the needed Limits files by scrolling through the Channel - Limits list box in the Measurement Limits dialog box.

---

**NOTE.** *When you reconstruct a worksheet from archived files, make sure that the limit files are placed into a sub-directory called “limits” under the directory that contains the CSS500.EXE file.*

---



---

**CAUTION.** *Make sure you don’t overwrite any existing files during reconstruction.*

---

## The WIN.INI File

The Cable TV Software and the Channel Table Editor place initialization settings in the WIN.INI file under the heading of CSS500 Connections. Initialization settings are only inserted in the file when necessary.

If the initialization settings in the WIN.INI file become corrupt for some reason, the CSS500 Connections section of the file can be completely deleted (but not while the application is running). The next time the software is run it will create a new CSS500 Connections section in the WIN.INI file when necessary.

## The CSS500.INI File

This section lists all of the lines in a typical CSS500.INI file, how they affect the application, and where they are editable. They can always be edited at the CSS500.INI file itself, but that is not a good practice, because it is error prone and CSS500 provides access to most of the parameters anyway. Unless that particular field can only be edited in the CSS500.INI file, edit them in the CSS500 application. (An example is the Demodulator topics that can only be edited via the CSS500.INI file.)

If the CSS500.INI file does become corrupt for some reason, it can be completely deleted (not while the application is running, though). The next time that CSS500 is run it will create a new CSS500.INI file. Some defaults may then need to be recreated to match your preferences.

**Table E-4: Contents of the CSS500.INI file**

Line in CSS500.INI File	Description
[CSS500]	General control of the CSS500 application window
Maximized=0	0 = Main window not maximized 1 = Main window maximized
Position=172,28,797,498	The last location of the upper left and lower right corners of the main application window in xy coordinates
[Sites]	This topic lists all of the Sites. This list of Sites continues to grow as you add more Sites in the Worksheet Info dialog box. The only way to remove Sites is to delete them from this file.
Num Sites=2	Total number of Sites in the list
Site Index=0	Which Site is loaded whenever a new worksheet is created or CSS500 is initially loaded
Site0=	Site names
Site1=Tektronix	
[Test ID]	This topic lists all of the Test IDs in your list. This list of Test IDs continues to grow as you add more Test IDs in the Test ID dialog box. The only way to remove Test IDs is to delete them from this file.



Table E-4: Contents of the CSS500.INI file (Cont.)

Line in CSS500.INI File	Description
Num Test IDs=4	Number of Test IDs in the list
Test ID Index=0	Which Test ID is the default. The default is loaded for all new worksheets or when CSS500 is first started.
Test ID0=Learner's Permit	Test ID names
Test ID1=	
Test ID2=Training Wheels	
Test ID3=TP888	
[File Defaults]	Default Channel Table file and Picture driver
Channel Table File=c:\css500\std.cht	This is the Channel Table file used for new worksheets. Update this with the Worksheet Info dialog box (under the Configure Menu).
Video Driver=VIDEO KIT	Used by View Picture. It can only be edited here. The Video Driver should be in the caption displayed by the Program Manager. This is the name of the Video Blaster board.
[Preferences]	These remember the last settings from the Preference dialog box (in the Configure menu).
Units=0	0 = dBmV 1 = dBV
History=1	0 = Save only most recent measurement 1 = Save History
Signal Connect=0	0 = Do not prompt for signal connection 1 = Prompt for signal connection
Pause on Channel=0	0 = Do not pause on new channel 1 = Pause on new channel
Pause on Alarm=0	0 = Do not pause on measurement alarm 1 = Pause on measurement alarm
Pause on Caution=0	0 = Do not pause on measurement caution 1 = Pause on measurement caution
Pause on Error=0	0 = Do not pause on measurement error 1 = Pause on measurement error
Execute VM700A Function on Error=0	0 = Do not execute VM700A function on measurement error 1 = Execute VM700A function on measurement error
Execute VM700A Function on Alarm=0	0 = Do not execute VM700A function on measurement alarm 1 = Execute VM700A function on measurement alarm
Execute VM700A Function on Caution=0	0 = Do not execute VM700A function on measurement caution 1 = Execute VM700A function on measurement caution
Report out RS232 on Error=0	0 = Do not report out the RS-232 port on measurement error 1 = Report out the RS-232 port on measurement error
Report out RS232 on Alarm=0	0 = Do not report out the RS-232 port on measurement alarm 1 = Report out the RS-232 port on measurement alarm

**Table E-4: Contents of the CSS500.INI file (Cont.)**

Line in CSS500.INI File	Description
Report out RS232 on Caution=0	0 = Do not report out the RS-232 port on measurement caution 1 = Report out the RS-232 port on measurement caution
[Measurement Limits]	Edit these from the Configure menu, Measurement Limits.
Default Limits File=ntsc.lim	Can update via the Save As Defaults command button in the Edit Limits dialog box
Default Audio Limits File=System~Default	The Default Audio limits file. You can only update this default value from the CSS500.INI file.
Sys Vis Car Level Caution UL=6	Edit this in the Summary Limits in the Measurement Limit Dialog box using Save As Defaults.
Sys Vis Car Level Alarm UL=10	Edit this in the Summary Limits in the Measurement Limit Dialog box using Save As Defaults.
Adj Vis Car Level Caution UL=2	Edit this in the Summary Limits in the Measurement Limit Dialog box using Save As Defaults.
Adj Vis Car Level Alarm UL=3	Edit this in the Summary Limits in the Measurement Limit Dialog box using Save As Defaults.
[Measurement Setups]	Edit these parameters using the Measurement Setups command from the Configure menu. These values are the ones that have been stored using "Saved As Default".
Ext Atten Amp=0	The value in dB of the 2714 external attenuation/amplification
2714/2715 Preamp=0	0 = off 1 = on
TDC-10 Preamp=0	0 = off 17 = 17 dB 27 = 27 dB
Power Line Freq=60	60 = 60 Hz 50 = 50 Hz
Carrier Levels Mode=0	0 = Accurate Frequency and Amplitude 1 = Accurate Amplitude only 2 = Fast Amplitude only
Zero Carrier Pulse Line=13	The line number where the Zero Carrier Pulse is found
Zero Carrier Pulse Field=1	The field where the Zero Carrier Pulse is found
Zero Carrier Pulse Center=3.5e-005	Location of the center of the Zero Carrier Pulse
Carrier Noise Mode=0	0 = Auto 1 = Auto with Pause 2 = Gated
Noise Bandwidth=4e+006	In Hz
CSO Mode=0	0 = Auto 1 = Auto with Pause 2 = Single Sweep 3 = Gated
CSO Loc1=-1.25e+006	

Table E-4: Contents of the CSS500.INI file (Cont.)

Line in CSS500.INI File	Description
CSO Loc2=-750000	
CSO Loc3=750000	
CSO Loc4=1.25e+006	
CSO Loc5=UNDEFINED	
CTB Mode=0	0 = Auto 1 = Auto with Pause 2 = Single Sweep
CTB Loc1=0	
CTB Loc1 Abs/Rel=1	0 = Abs 1 = Rel
CTB Loc2=UNDEFINED	
CTB Loc2 Abs/Rel=1	0 = Abs 1 = Rel
CTB Loc3=UNDEFINED	
CTB Loc3 Abs/Rel=1	0 = Abs 1 = Rel
CTB Loc4=UNDEFINED	
CTB Loc4 Abs/Rel=1	0 = Abs 1 = Rel
CTB Loc5=UNDEFINED	
CTB Loc5 Abs/Rel=1	0 = Abs 1 = Rel
ICR Mode=0	0 = RF 1 = baseband
ICR Gated=0	0 = not gated 1 = gated
ICR RF Loc1=-500000	
ICR RF Loc2=500000	
ICR RF Loc3=1e+006	
ICR RF Loc4=2e+006	
ICR RF Loc5=3e+006	
ICR RF Loc6=3.58e+006	
ICR BB Loc1=500000	
ICR BB Loc2=1e+006	
ICR BB Loc3=2.5e+006	
ICR BB Loc4=3e+006	
ICR BB Loc5=3.58e+006	

Table E-4: Contents of the CSS500.INI file (Cont.)

Line in CSS500.INI File	Description
ICR BB Loc6=4e+006	
ICR BB Loc7=4.18e+006	
ACL Mode=2	0=Upper 1=Lower 2=Both
Modulation Depth Mode=0	0 = RF 1 = baseband
VM700A Source=0	0 = Baseband source is Channel A or C 1 = Baseband source is Channel B
NTSC Multiburst Line=17	VITS information
NTSC Multiburst Field=1	
NTSC Composite Line=18	
NTSC Composite Field=1	
NTSC Combination Line=17	
NTSC Combination Field=2	
NTSC Noise Line=12	
NTSC Noise Field=1	
NTSC Color Bars Line=17	
NTSC Color Bars Field=2	
PAL Luminance Bar Start Line=17	
PAL Luminance Bar Start Center=1.2e-005	
PAL Luminance Bar Width Center=1e-005	
PAL Luminance Bar Reference Center=1.7e-005	
PAL 2T Sine-Squared Pulse Line=17	
PAL 2T Sine-Squared Pulse Center=1.2e-005	
PAL 5-Riser Luminance Staircase Line=330	
PAL 5-Riser Luminance Staircase Center=4e-005	
PAL 5-Riser Modulated Staircase Line=330	
PAL 5-Riser Modulated Staircase Center=4e-005	
PAL Modulated 3 Step Line=331	
PAL Quiet Line=22	
PAL Multiburst Line=18	
PAL Multiburst Flag Center=1.2e-005	
PAL Multiburst Flag Width Center=8e-006	
PAL Multiburst Packet 1 Center=1.45e-005	
PAL Multiburst Packet 2 Center=2.05e-005	

Table E-4: Contents of the CSS500.INI file (Cont.)

Line in CSS500.INI File	Description
PAL Multiburst Packet 3 Center=2.65e-005	
PAL Multiburst Packet 4 Center=3.25e-005	
PAL Multiburst Packet 5 Center=3.85e-005	
PAL Multiburst Packet 6 Center=4.45e-005	
PAL Sin X/X Line=16	
[Demodulator]	
Demod=1	0 = TDC-10/1450A 1 = TV1350 2 = EMFP 4 = none
Attenuation=1 EMFP and r-s only	This parameter is only for the EMFP and TV1350. 1 = Auto 0 = 0 dB 10 = 10 dB 20 = 20 dB
Input=75	This parameter is only for the EMFP and TV1350. 75 = 75 Ohms 50 = 50 Ohms
Level=0	This parameter is only for the EMFP and TV1350. 0 = Low (off) 1 = High (on)
Trap or SAW=0	This parameter is only for the EMFP and TV1350. 0 = Trap 1 = SAW
Sound=1	This parameter is only for the EMFP and TV1350. Sound Trap (or SAW Filter) 1 = on 0 = off
Zero Reference Pulse=1	This parameter is only for the EMFP and TV1350. 1 = on 0 = off



## Appendix F: Wiring Diagram

Figure F-1 is the wiring diagram for the CMP500 Cable Television Measurement Package. Another way of wiring the equipment, using a TV1350, is given in Figure F-2. Figure F-3 illustrates using an EMFP and Figure F-4 shows how to use a switcher. CSS500 can operate with only some of the test equipment connected, but it cannot make measurements requiring those instruments not present. See Table F-1 for a list of equipment required to make measurements.

**Table F-1: Equipment required for the measurement**

Measurement	RF <sup>1</sup>	BB <sup>2</sup>
Carrier Levels and Frequencies	x	
Carrier to Noise	x	
CSO	x	
CTB	x	
Cross Modulation	x	
In-Channel Response <sup>3</sup>	x	x
Hum/LFD	x	
FCC Baseband		x
Modulation Depth	x	x
Aural Deviation	x	
Signal to Noise		x
Waveform Distortion		x
Multiburst		x
ICPM		x
Audio		x

<sup>1</sup> RF equipment includes the 2714 or 2715.

<sup>2</sup> BB (Baseband) equipment includes: the VM700A and either the TDC-10/1450A combination, a TV1350 Demodulator, or an EMPF.

<sup>3</sup> If both are checked, use either RF or BB equipment to make the measurement.

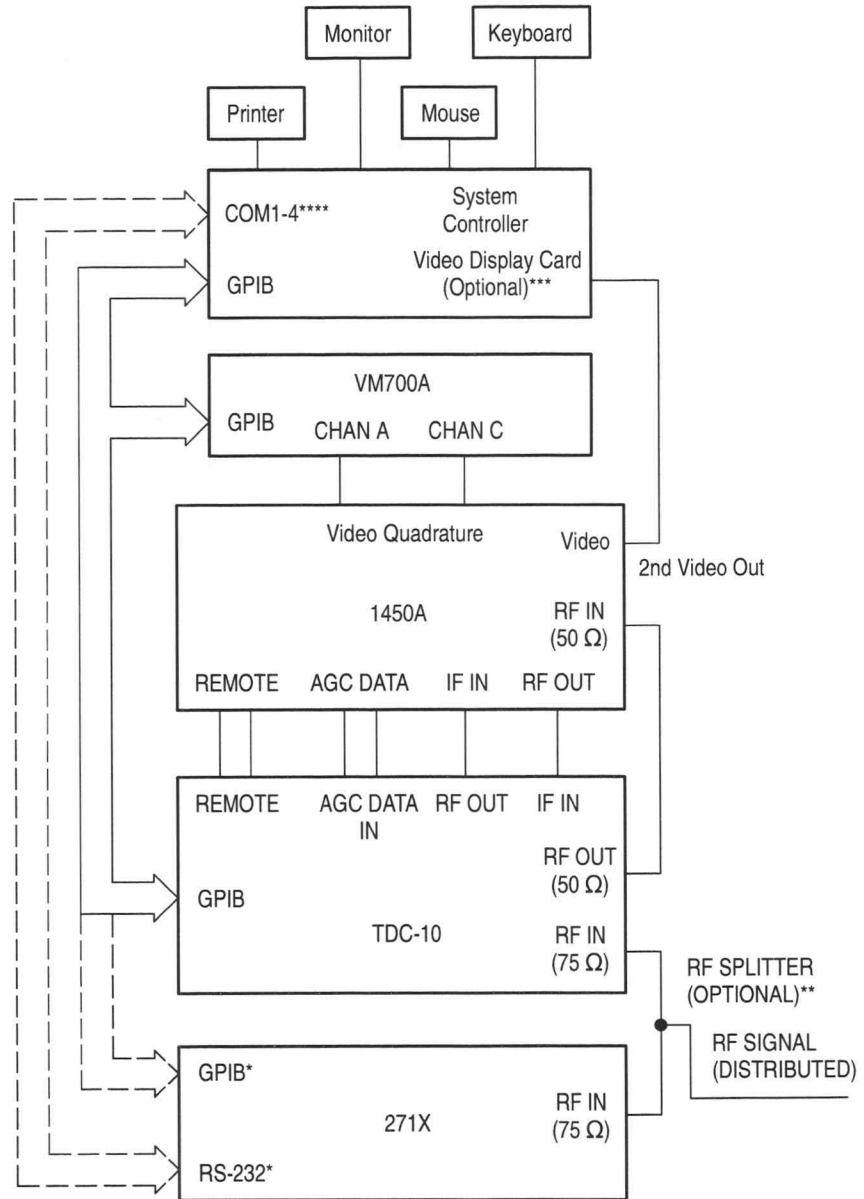

\*One, not both  
 \*\*RF signal can be manually switched between the 271X and TDC-10  
 \*\*\*For View Picture only  
 \*\*\*\*COM Port only needed if 271X is RS-232

Figure F-1: Wiring diagram for CMP500



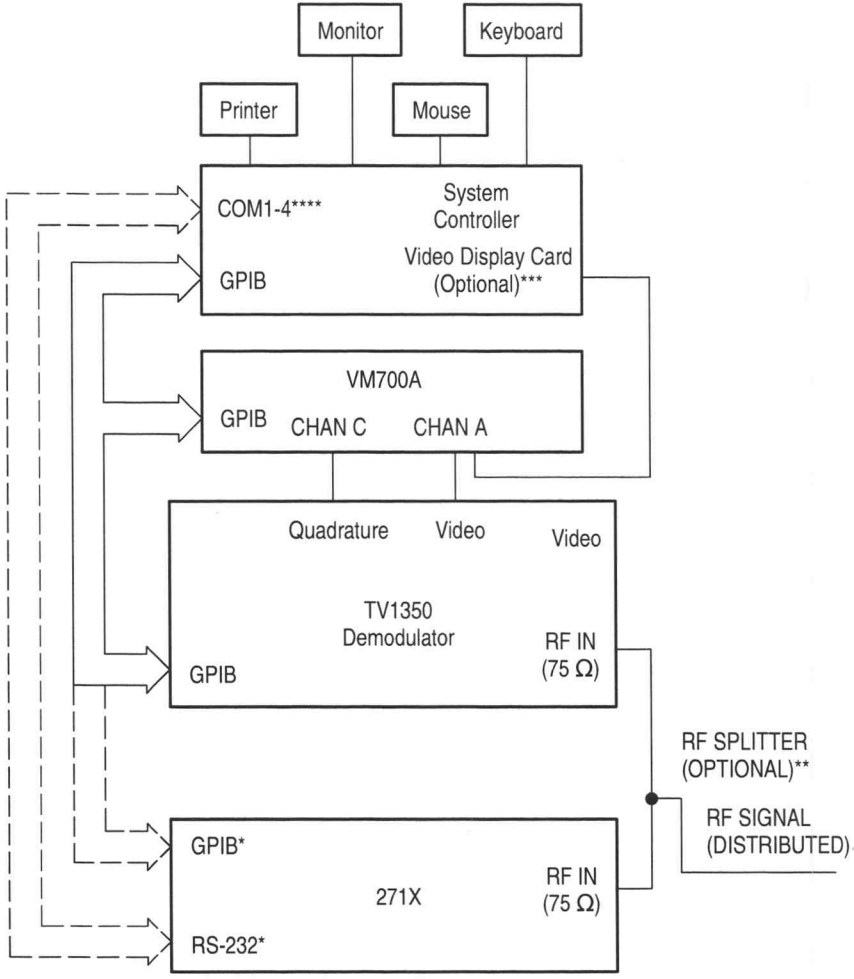

\*One, not both  
 \*\*RF signal can be manually switched between the 271X and TV1350  
 \*\*\*For View Picture only  
 \*\*\*\*COM Port only needed if 271X is RS-232

Figure F-2: Wiring diagram using the TV1350 instead of the TDC-10 and 1450A

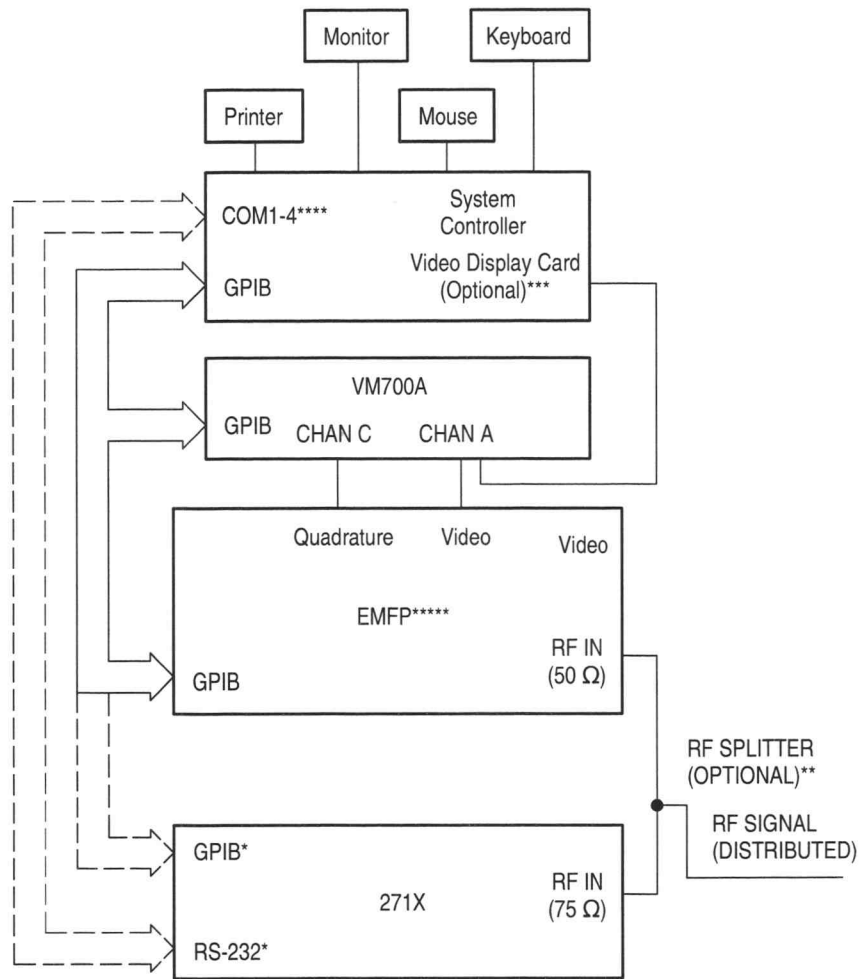

\*One, not both  
 \*\*RF signal can be manually switched between the 271X and EMFP  
 \*\*\*For View Picture only  
 \*\*\*\*COM Port only needed if 271X is RS-232  
 \*\*\*\*\*EMFP is only for PAL systems

Figure F-3: Using the EMFP

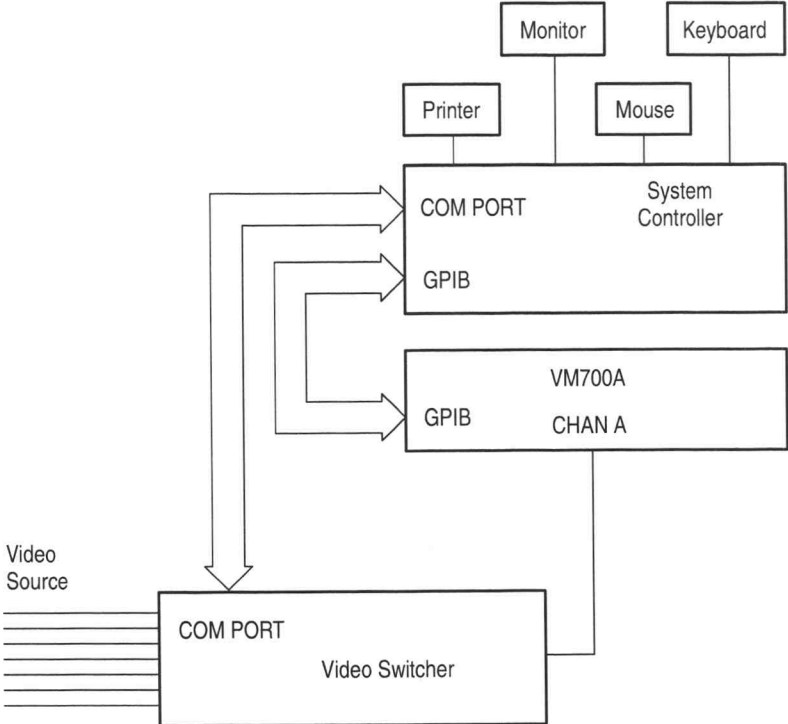

Figure F-4: Using a switcher



## Appendix G: Controlling a 2714/2715 Over a Modem

This section describes a method of using the CSS500 Cable TV System Software to control a 271X analyzer remotely over modems. This section assumes you are using the Windows Terminal program; however, you can use any equivalent program. The Windows Terminal program is used to dial the modem and establish communication with the remote modem and analyzer. The Terminal program is then exited and the CSS500 Software is started. The Software doesn't know or care whether it is talking to the analyzer directly or if there are modems in between. When the user is done using the Software, it is exited and the Terminal program is restarted and used to hang up the modems.

To ensure reliable operation, you should use modems that support hardware flow control and error correction. Some operations (for example, sending a large channel table) send large binary files to the 271X. At baud rates of 2400 and higher, the 271X may not be able to keep up with the PC. If any data is lost or corrupted, the 271X may operate unpredictably. This is especially inconvenient if the analyzer is at a remote location. Using hardware flow control and error correction allows reliable performance.

The details of the setups for the PC, modems and 271X follow. The modem commands listed are from the standard Hayes command set. If the commands for your modems are different, use the appropriate commands to configure the features as described below.

### Terminal Program Settings

Set the Terminal communications settings as shown in Table G-1.

**Table G-1: Settings for Windows Terminal program**

Communication Setting	Value
Baud rate	9600
Data bits	8
Stop bits	1
Parity	none
Flow control	hardware
Parity check	unchecked
Carrier detect	unchecked
Connector	com2

A baud rate of 9600 is the fastest the 271X can handle. The port can be set to use whatever baud rate is available.

The CSS500 Software Connections settings must match the port and baud rate selected in the Windows Terminal program.

## Local Modem Settings

Set up the local modem with the commands shown in Table G-2.

**Table G-2: Settings for local modem**

Command	Description
Baud rate	Since the PC starts by sending "AT" commands to the modem, the modem determines the rate of the incoming "AT" characters and communicates with the PC at that rate. 9600 is recommended.
AT &F	Start with known factory settings.
AT \N3	AutoReliable connection. Makes the fastest possible connection and uses the best possible error correction and data compression. (Optional).
AT &K3	Enable RTS/CTS hardware flow control.
AT &Q5	Use asynchronous error correction mode.
AT &D0	Ignore on-to-off transitions of DTR. This keeps the modem from hanging up when the Terminal program is exited and the PC drops DTR before the CSS500 Software is started.
AT N1	Connect at the highest rate supported by both modems. (Optional).
AT &W0	Write these settings in profile 0. This profile is loaded and used when the modem is turned on.

## Remote Modem Settings

Connect the remote modem to a terminal to establish these settings and store them. Set up the modem with the following commands:

**Table G-3: Settings for remote modem**

Command	Description
Baud rate	The modem determines the rate based on the incoming "AT" commands sent to it during configuration. The rate at which the terminal talks to the modem during this configuration session is remembered by the modem and is the rate at which the modem will communicate with the device at the remote end. A baud rate of 9600 is recommended.
AT &F	Start with known factory settings.

**Table G-3: Settings for remote modem (Cont.)**

Command	Description
AT \N3	AutoReliable connection. Makes the fastest possible connection and uses the best possible error correction and data compression. (Optional).
AT &K3	Enable RTS/CTS hardware flow control.
AT &Q5	Use asynchronous error correction mode.
AT N1	Connect at the highest rate supported by both modems. (Optional).
AT S0=n	Sets the modem to auto-answer on the nth ring. Note that the "0" in "S0" is a zero.
AT Q1	Disable results codes. The 271X does not understand results codes and will generate syntax error messages if it receives them.
AT E0	Inhibit command echo. The 271X should not be sending anything to the modem before the link is established, so this is just an added precaution.
AT &W0	Write these settings in profile 0. This profile is loaded and used when the modem is turned on.

## 271X Settings

Press the UTIL/4/0/2 keys to get to the RS-232 settings menu. Configure the 271X as shown in Table G-4.

**Table G-4: Settings for the 271X**

	Setting	Value
0	STATUS	ONLINE
1	BAUD	Must match the remote modem setting
2	DATA BITS	8
3	PARITY	NONE
4	EOL	CRLF
5	FLOW CONTROL	HARD (RTS/CTS)
6	ECHO	OFF
7	VERBOSE	OFF







# Glossary

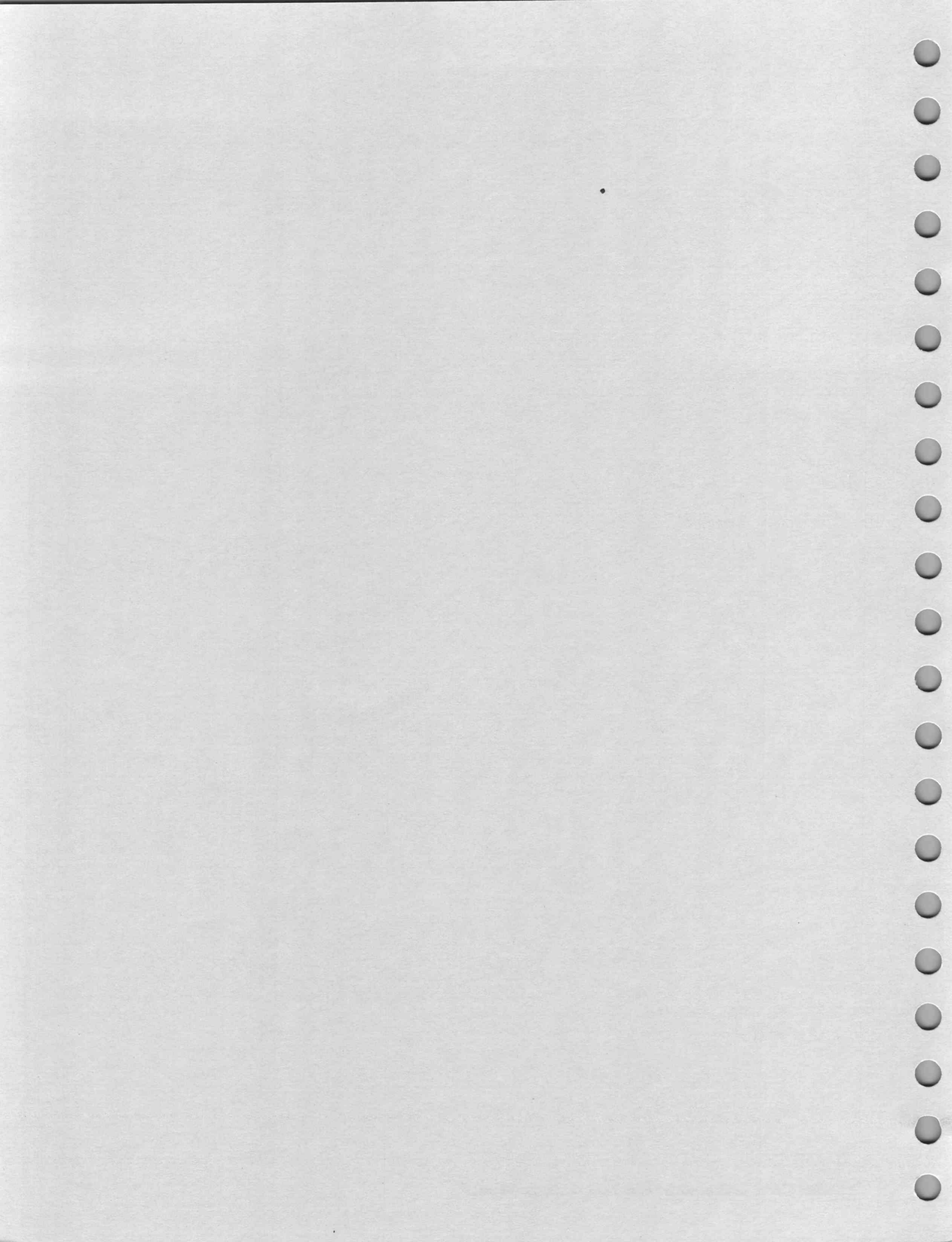

# Glossary

**Accuracy**

The closeness of the indicated value to the true value.

**Adjacent Channel Leakage**

The power in the channels adjacent to the channel under test that is due to leakage from the channel under test.

**Aural Deviation**

The peak FM deviation measured for the selected channel.

**Average Power**

The integral of the power spectral density of all screen locations between the edges of the channel.

**Carrier Levels and Frequencies**

Carrier levels is the peak amplitude with the preamp off. Carrier Frequencies is the frequency measured against the frequency of the internal counter of the instrument.

**Carrier to Noise**

The ratio of the carrier to noise amplitude with the default noise floor normalized to 4 MHz relative to the visual carrier peak.

**Cross Modulation**

The peak fundamental component of 3rd order distortion at the horizontal sync frequency (AM) measured on the unmodulated visual carrier.

**CSO (Composite Second-Order)**

Distortion from second-order intermodulation distortion.

**CTB (Composite Third-Order or Triple Beat)**

Distortion from third-order intermodulation distortion.

**Desired to Undesired**

The ratio of the average power of the desired signal to the average power of undesired signals.

**Hum/LFD**

Hum/Low Frequency Disturbance is the power line frequency measured on an unmodulated visual carrier and low frequency disturbance measured on the modulated carrier.

**In Channel Response**

The maximum variance in amplitude within a specified frequency range within a particular channel, given a flat input over that same range.

**Modulation Depth**

The percent amplitude modulation measured from sync tip to the lowest white level in 10 sweeps.

**UDP (User Defined Program)**

A measurement sequence loaded into a 271X and run at a remote location.



# Index

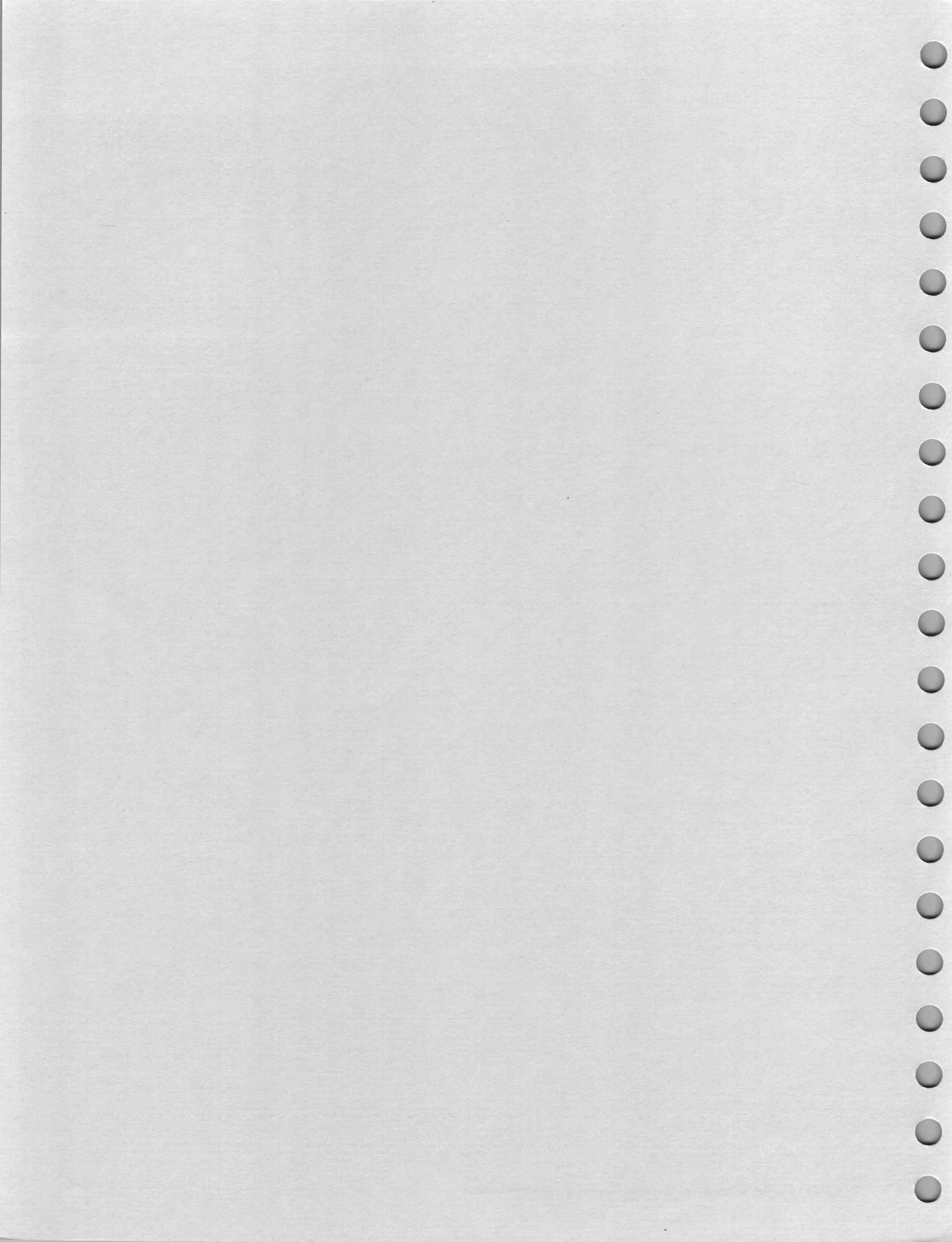

# Index

## Symbols

- \* , 3-30, 3-33
- \*.cht, E-1, E-2
- \*.hlp, B-5
- \*.lim, E-1, E-2
- \*.wrk, E-1, E-2
- \*.wsr, 2-66, 2-89, 2-90, 3-47, E-2
- \*\* , 3-30, 3-33
- <-Select Limits File, Measurement Limits, 3-64, 3-65

## Numbers

- 1450A, Zero Carrier Pulse, 2-43
- 24 Hour Carrier Level Variation, 3-30
- 24 Hour Carrier Summary, 3-36
- 24 Hour Test, 2-31
- 2714
  - External Attenuation/Amplification, 3-72
  - Power Line Frequency, 3-72
  - Preamp, 3-72
- 2714/2715
  - External Attenuation/Amplification, 2-42
  - Power Line Frequency, 2-43
  - Preamp, 2-43
- 2714/2715 Channel Type, channel information, C-29
- 2714/2715 Screen, 3-40
- 2714/2715 Second Aural, channel information, C-29
- 2715, preamp, 2-43
- 271X, Aural Deviation, "Measurement Time", 3-6

## A

- About, Channel Table Editor, C-27
- About dialog box, 3-85
- accuracy, Glossary-1
- ACL Group, Edit Setups, 2-47, 3-74
- Adjacent Channel Lkg, Glossary-1
- Adjacent Limits, Visual Carrier Level Differences, 2-84
- Adjacent Visual Carrier Level Difference, 3-69
- Alarm, 2-55, 2-63, 3-39, 3-54
  - CSS500~ALARM\_OFF, 3-54, 3-55
  - CSS500~ALARM\_ON, 3-54, 3-55
  - Intercepting, 3-55
  - Limits, 3-64
- Alarm Limits, 2-81
- Amplitude Offset, Channel Information, C-30
- Append, Channel Table Editor, C-18

- Archive, E-5
- Audio Limits, 2-84, 3-68
- Aural Carrier Offset, Limits, 3-66
- Aural Deviation, Glossary-1
- Aural Offset, B-7
  - Channel Table Information, C-29
  - Edit Table Info, C-19
- Auto Selection, 3-57
- Average Power, Glossary-1

## B

- Blue, 2-23, 3-30, 3-39
- Button Bar, 3-86
  - Channel Table Editor, C-28
- By Channel Number, Sort, C-20
- By Frequency, Sort, C-20
- By Program, Sort, C-20

## C

- C/N Bandwidth, Channel Information, C-30
- Carrier Amplitude Units, Preferences, 3-54
- Carrier Levels and Frequencies, Glossary-1
- Carrier Levels Units, 2-54
- Carrier Survey, 2-34
  - UDP, 3-45, 3-58
- Carrier to Noise, 2-46, Glossary-1
  - Auto, 2-46
  - Auto with Pause, 2-46
  - Edit Setups, 3-73
  - Gated, 2-46
- Caution, 2-63, 3-39
  - Limits, 3-64
- Caution Limits, 2-81
- Cell Color, 2-23
- Chan Table, 2-5
- Channel Edge, channel information, C-29
- Channel Header, 3-5
  - Number, 3-5
  - Program, 3-5
  - Tag, 3-5
  - Visual Frequency, 3-5
- Channel Number, B-7
- Channel Summary, 3-36
  - from Global View, 3-39
- Channel Table, 2-49, 3-4, 3-12, B-2, B-5, B-9, B-11
  - Automatic Loading, C-10
  - Clear, C-3

- Create a New, C-3
- Get 2714 Stored Results, 3-47
- Get 2714/2715 Stored Results, 2-92
- Loading, C-11
- UDP, 3-60
- Worksheet Info, 3-50
- Channel Table Editor, C-1
  - TDC-10 using RS-232, C-12
- Channel Table Fields, View, C-20
- Channel Table File, E-5
- Channel Table Mismatches, C-10
- Channel Table Names, C-10, C-11
- Channel Tables, Provided, C-12
- Channel Width, B-7
  - channel information, C-29
  - Edit Table Info, C-19
- Channel Number, Channel Information, C-29
- Clear, 3-25
- Clear Limits, Edit Limits File, 3-68
- Clear Limits File, Measurement Limits, 3-65
- Close, 3-10
  - Channel Table Editor, C-17
  - Help, 3-85
- Configure, 3-49
- Connections, 3-81
  - Channel Table Editor, C-26
- Contents
  - Channel Table Editor, C-27
  - Help, 3-84
- Control Menu Box, 3-9
- Copy, 2-66, 3-23, B-4
  - As Displayed, 2-68, 3-23
  - Compared to Export, 3-16
  - Export Format, 2-67, 3-23
  - into Excel, 2-68
- Copy Fields to End, Channel Table Editor, C-8, C-18
- Copy to All Channels, Edit Setups, 2-49, 3-80
- Create/Edit Channel Table, 3-12, 3-51
- Cross Modulation, Glossary-1
- CSO, 2-47, B-4, E-8, Glossary-1
  - 2714 displaying CTB, 2-62
  - Distinguishing between CTB and CSO, 3-75
  - Edit Setups, 3-74
  - Get 2714 Stored Results, 3-48
  - Measurement Setup Restrictions, 3-75
- CSS500 and CSS150, E-4
- CSS500.INI, 1-8, B-4, E-6
- CSS500~ALARM\_OFF, 2-55, 3-54, 3-55
- CSS500~ALARM\_ON, 2-55, 3-54, 3-55
- CTB, 2-47, B-4, E-9, Glossary-1
  - Distinguishing between CTB and CSO, 3-75
  - Edit Setups, 3-74
  - Get 2714 Stored Results, 3-48

- Measurement Setup Restrictions, 3-75
- CTLOADE, B-5, C-2
  - Installation, 1-3
- Current Selection, 2-17, 2-19, 3-45
- Cursor, 3-8
- Customer Support, xiii

## D

- delay flag, 1-8
- Delete, Channel Table Editor, C-18, C-23
- Demodulator, 3-83
  - CSS500.INI, E-11
  - Setup, 2-41
- demodulator, 1-8
  - selecting, 1-8
  - setup, 1-10, 2-40
- Demodulator Command, 3-83
- Description, 3-12
  - Worksheet Info, 3-51
- Desired to Undesired, Glossary-1
- Dwell Time, Channel Information, C-30

## E

- Edit, 3-23
  - Channel Table Editor, C-17
- Edit Channel Info, Channel Table Editor, C-28
- Edit Limits File, Measurement Limits, 3-65
- Edit Setups, Measurement Setups, 3-72
- Edit Table Info, Channel Table Editor, C-3, C-19, C-28
- Edit Time Parameters
  - Measurement Sequence, 3-59
  - UDP, 2-86
- EMFP, 1-5, 2-39
  - Channel Tables, 2-51, C-12
  - Selecting, 2-39
- Error, 3-30
  - Get 2714 Stored Results, 3-48
  - Import, 3-15
- Error Messages, B-1
- Excel, 2-67, 2-69
  - Copying into, 2-68
- Excel Limitations, 3-25
- Exit, 3-22
  - Channel Table Editor, C-15
- Expand Columns, 2-37, 3-17
  - printing, 3-17
- Export, 2-71, 3-16, B-4
- Export Format, Copy, 3-23



## Export Results

Get 2714 Stored Results, 3-47

Get 2714/2715 Stored Results, 2-90

External Attenuation/Amplification, 2714 Measurement Setups, 3-72

**F**

FCC 24 Hour Measurements, 3-57

FCC Field Measurements, D-5

Collecting and Presenting Measurement Results, D-11

Defining, D-6

Execute UDPs, D-10

Post-Converter UDP, D-6

Pre-Converter UDP, D-8

Pre-Converter Worksheet, D-7

Visual Carrier Level &amp; Level Variation (30M) UDPs, D-9

FCC Headend Measurements, 2-31, 3-57, D-3

Summary, D-4

FCC Post-Converter, 2-31, 3-57

FCC Pre-Converter, 2-31, 3-57

File, 3-11

Channel Table Editor, C-15

Files, Naming Convention, E-2

From, Transfer, C-22

**G**

Gated

Carrier to Noise, 2-46

CSO, 2-47

Generate 2714 UDP, 3-60

Get 2714 Stored Results

Export Results, 3-47

Import Results, 3-47

Get Defaults

Edit Limits File, 3-67

Edit Setups, 3-79

Edit Setups, 2-48

Measurement Setups, 3-71

Get Stored Results from 2714, 3-46

Get Stored Results from 2714/2715, 2-89

Global, Button Bar, 3-86

Global View, 3-39

GPIB, 1-1, 1-10, 3-81, B-1, B-6, B-8, C-26

Address, 2-40

.GPIB Cables, 1-5

Gray, 2-23, 3-39

Green, 2-23, 3-30, 3-39

GVG Switcher Control, C-32

**H**

Hardware Installation, CMP500, 1-4

Hardware Requirements, PC, 1-1

Help, 3-84, B-4, B-5

Channel Table Editor, C-27

Tektronix Help Line, xiii

Help Files, Adding Information, E-3

History, 2-52, 2-66, 2-72, B-9, E-7

Copy, 3-24

Import, 3-14

Limits Files, 3-65

Preferences, 3-53

Results Detail, 3-32

Navigation, 3-33

Status Report, 3-27

Horizontal Scroll Bar, 3-7

Hum/LFD, Glossary-1

**I**

ICPM, 3-74

Restrictions, 2-47

ICR, E-9

ICR Test Line, Channel Information, C-30

Import, 3-14, B-9

Channel Number, 3-14

Channel Table, 3-14

Error, 3-15

History, 3-14

Site, 3-14

View Filter, 3-42

Import Channel Criteria, Get 2714/2715 Stored Results, 2-93

Import Results

Get 2714 Stored Results, 3-47

Get 2714/2715 Stored Results, 2-91

In Channel Response, 2-48, Glossary-1

Edit Setups, 3-74

Include in Transfer, Channel Information, C-31

Insert, Channel Table Editor, C-18

Intercepting an Alarm, 2-55, 3-55

**L**

Limit Check, Channel Table Editor, C-25

Limits

Button Bar, 3-86

Lower, 2-81, 3-66

Upper, 2-81

Visual Carrier Level Differences, 2-84

Limits command button, 2-80

- Limits File, 2-23, 2-79, 3-64, B-4, E-5
  - Attach to a Channel, 2-83
  - Edit, 2-83
  - Remove from a Channel, 2-83
- Limits sub-directory, 3-66
- Load a Channel Table, C-9

## M

- Maximize, 3-10
  - Channel Table Editor, C-15
- Maximize Button, 3-4
- Meas Sel, 2-17, 2-19
  - Button Bar, 3-86
- Meas Seq, 3-46, 3-56
  - Button Bar, 3-86
- Measure, 3-45
- Measurement, Setups
  - Modulation Depth, 2-46
  - VM700A Source, 2-47
- Measurement Execution, 2-54
- Measurement Header, 3-6
- Measurement Limits, 2-80, 3-64
- Measurement Sequence, 2-78, 3-56, B-3, B-10
  - FCC Headend Measurements, D-3
  - Generate 2714 UDP, 3-60
  - Switching to Other Applications, 2-29, 3-46
  - UDP, 2-88
  - View Filter, 2-30
- Measurement Sequence Results, 2-76, 3-43
  - Disabled Commands, 3-43
- Measurement Setups, 2-41, 3-70
  - Carrier to Noise, 2-46
  - CSO, 2-47
  - CTB, 2-47
  - In Channel Response, 2-48
  - UDP, 2-86
  - VITS, 2-47
- Measurement Summary, 3-38
  - from Global View, 3-39
  - Results Detail, 3-33
  - Status Report, 3-27
- Measurements, Switching to Other Applications, 2-20
- Measurements and Channels, 2-73, 3-40
  - View Used, 3-42
- Memory, B-3, B-9
- Menu Bar, 3-11
- Minimize, 3-10
  - Channel Table Editor, C-14
- Minimize Button, 3-4
- Modulation Depth, 2-46, Glossary-2
  - Edit Setups, 3-73

- Mouse, 3-8
- Mouse Button
  - Double-Click, Left, 3-45
  - Right, 2-22, 2-60, 2-65, 3-26, 3-32
- Move, 3-9
  - Channel Table Editor, C-14
- MSMT.DLL, E-4
- MSMTREAL.DLL, E-4
- MSMTSTUB.DLL, E-4

## N

- Navigation, Results Detail, 3-32
- New, 3-11
  - Channel Table, 3-12
  - Channel Table Editor, C-15
  - Description, 3-12
  - Site, 3-12
- Non-US countries, Measurement Sequence changes, 2-31
- Notes, 3-33
- Number, 3-5
- Number of Channels
  - Edit Table Info, C-19
  - maximum, C-19

## O

- Offset Frequency, Channel Information, C-31
- Older CSS500 Versions, E-4
- Open, 3-13
  - Button Bar, 3-86
  - Channel Table Editor, C-15
- Open Limits File, Edit Limits File, 3-67
- Operator Input, UDP, 3-62
- Organizing, D-1
- Out of Bounds Limits, Channel Table Editor, C-11

## P

- PAL VITS, 2-47
- Parameters, 2-85, 3-70
- pasting into Word for Windows, 3-24
- Pause Execution, 2-55
- Pause on Measurement Alarm, E-7, E-8
  - Preferences, 3-54
- Pause on New Channel, 2-54, E-7
  - Preferences, 3-54
- Pesa Switcher Control, C-32
- Picture, 2-35, 3-40, B-5
- ports, C-26

Power Line Frequency, E-8  
 2714 Measurement Setups, 3-72

Preamp  
 2714 Measurement Setups, 3-72  
 2715, 2-43  
 TDC-10 Measurement Setups, 3-72

Preferences, 2-51, 3-52  
 Carrier Levels Units, 2-54  
 History, 2-52  
 Measurement Execution, 2-54  
 Pause Execution, 2-55  
 Pause on New Channel, 2-54  
 Prompt for Signal Connection, 2-54  
 UDP, 2-86, 3-60

Print, 2-35, 3-17  
 Button Bar, 3-86  
 Channel Table Editor, C-16  
 Portrait or Landscape, 2-36, 3-18

Print Setup, 3-22  
 Channel Table Editor, C-17

Printing, Expand Columns, 2-37, 3-17

Program, 3-5  
 Channel Information, C-29

Prompt for Signal Connection, 2-54, E-7

## Q

Quiet Line, Channel Information, C-30

## R

Red, 2-23, 3-30, 3-39

Repeat Interval, Measurement Sequence, 3-60

Report out RS-232, Error, Caution, Alarm, 2-55

Restore, 3-9  
 Channel Table Editor, C-14

Restore Button, 3-4

Result Detail, From Global View, 3-39

Results, 2-60, 2-65  
 Button Bar, 3-86

Results Detail, 2-60, 3-32, B-4  
 Notes, 3-33

Results Detail Display, 2-60, 2-65  
 Navigation, 2-61

RFM150 Channel Type, Channel Information, C-29

RFM150 CN BW, Channel Information, C-30

RFM150 Second Aural Offset, Channel Information,  
 C-30

RS-232, 1-1, 1-10, 3-82, B-1, C-26  
 Address, 2-40

RS-232 Violations Reporting, 1-10

## S

Save, 3-13  
 Button Bar, 3-86  
 Channel Table Editor, C-16

Save As, 3-13  
 Channel Table Editor, C-16

Save as Default, Worksheet Info, 3-51

Save as Defaults  
 Edit Limits File, 3-67  
 Edit Setups, 2-49, 3-80  
 Measurement Setups, 3-71

Save As Limits File, Edit Limits File, 3-67

SAW, E-11

Scrambling, 2-18  
 Channel Information, C-30

Select  
 Channel Table Editor, C-24  
 Column, 2-13  
 Row, 2-13

Select All, 3-25

Sequence, 3-46

Setup, command button, 2-41

Setups, Button Bar, 3-86

Short Time Distortion, 3-7

Site, 2-5, 3-5, 3-12, 3-14, B-4, E-6  
 Get 2714 Stored Results, 3-47  
 UDP, 3-63, D-10  
 Worksheet Info, 3-50

Size, 3-10  
 Channel Table Editor, C-14

Software Installation, 1-2

Sort, Channel Table Editor, C-20

Start Time, Measurement Sequence, 3-59

Status, 2-63, 3-26  
 Button Bar, 3-86

Status Report, 2-62, 3-26  
 from Global View, 3-40  
 Measurement Summaries, 3-27

Summary Limits, 2-84, 3-69

Switch To, 3-10  
 Channel Table Editor, C-15

switcher, delay flag, 1-8

Switcher Control String, C-26  
 Channel Information, C-31

Sync Polarity, Channel Information, C-31

## T

T-Channels, C-12, C-13

- Table Information List Box, Channel Table Editor, C-29
- Table Name, Edit Table Info, C-19
- Tag, 3-5
  - Channel Information, C-29
- TDC-10, 1-7
  - Preamp, 2-43, 3-72, E-8
- TDC-10 Aural Offset, Edit Table Info, C-19
- Test ID, 2-5, 3-5, 3-52, B-4, E-6
  - All Test IDs, 3-52
  - Button Bar, 3-86
  - Results, 2-78
  - UDP, 2-86, 3-60
  - View Filter, 3-44
  - Worksheet Test ID, 3-52
- Test Pulse Offset, Channel Information, C-31
- Title Bar, 3-3
- To, Transfer, C-22
- Transfer, B-6
  - Channel Table Editor, C-21
  - To, C-9
- Trap, E-11
- Tune to Channel, 3-46
  - Picture, 2-35
- TV1350, 1-5
  - Channel Tables, 2-51, C-12
  - Selecting, 2-39
  - Switch Signal Message, 2-21
  - Wiring Diagram, F-3
  - Zero Carrier Pulse, 3-72

## U

- UDP, 2-86, 3-60, B-2, B-4, Glossary-2
  - Defining, 2-86
  - Running, 2-88
- Upper Limits, 3-66
- Use ICR, Channel Information, C-30
- Use Quiet, Channel Information, C-30
- Use White, Channel Information, C-30

## V

- Vertical Scroll Bar, 3-7
- Video Driver, 3-40
- Video Polarity, Channel Information, C-31
- Video Standard, B-6
  - Edit Table Info, C-19
- View, 3-26
  - Channel Table Editor, C-20
- View Fields, Channel Table Editor, C-28

- View Filter, 2-66, 2-73, 3-42, B-4, B-9, B-10
  - Measurement Results, 3-70
  - Measurement Sequence Results, 2-30, 2-76, 3-43
  - Measurements and Channels, 2-73, 3-40
  - Status Box, 2-5, 3-5, 3-41, 3-43, 3-44
  - Test ID, 3-44
  - Test ID Results, 2-78
  - View Used, 3-42
- View Results Detail
  - Status Report, 3-30
  - View Violations, 3-31
- View Used, 3-42
  - Measurement and Channel View Filter, 2-37
- View Violations, 2-63, 3-30
  - Status Report, 3-30
  - View Results Detail command button, 2-65
- Violations Report, Report Out RS-232, 2-55
- Violations Reporting, 1-10
- Visual Carrier Frequency, B-7
  - Limits, 3-66
- Visual Carrier Level Differences, 3-69
- Visual Frequency, 3-5
  - Channel Information, C-29
- VITS, 2-44, 2-47
  - NTSC, Edit Setups, 3-76
  - PAL, Edit Setups, 3-76
  - VM700A, 2-44
- VM700A
  - Alarm Functions, 3-54
  - Alarms, 2-55
  - VITS, 2-44
- VM700A Source, 2-47
- VM700A Sources, ICPM, 3-74

## W

- White, 2-23, 3-30, 3-39
- White Line, Channel Information, C-30
- WIN.INI, E-6
- Windows NT, 1-1
- Wiring Diagram, F-1, F-2
- Worksheet, 2-3, 2-5, 3-4
  - Maximum Size, E-1
- Worksheet File, E-5
- Worksheet Header, 3-4
  - Chan Table, 3-4
  - Site, 3-5
  - Test ID, 3-5
  - Worksheet, 3-4
- Worksheet Info, 3-50
  - UDP, 2-86

**Y**

Yellow, 2-23, 3-30, 3-39

**Z**

Zero Carrier Pulse, 2-43, 3-72, E-8  
TV1350, 3-72  
Zero Carrier Reference Pulse, TV1350, 1-8



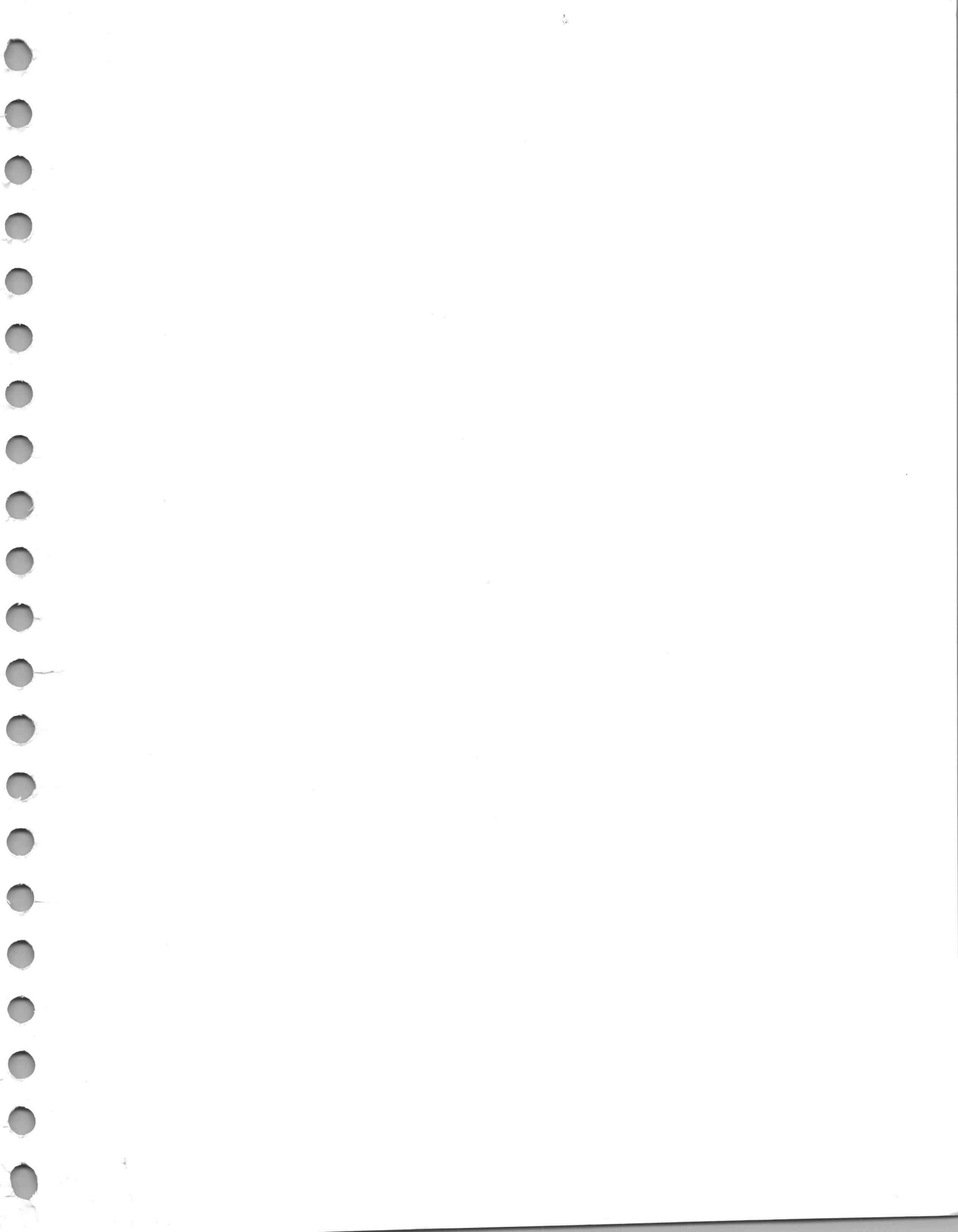



Printed on recyclable paper. Please recycle.