

Stan Griffiths

INSTRUCTION MANUAL

326
DUAL-TRACE
OSCILLOSCOPE

Serial Number _____



WARRANTY

All TEKTRONIX instruments are warranted against defective materials and workmanship for one year. Any questions with respect to the warranty should be taken up with your TEKTRONIX Field Engineer or representative.

All requests for repairs and replacement parts should be directed to the TEKTRONIX Field Office or representative in your area. This will assure you the fastest possible service. Please include the instrument Type Number or Part Number and Serial Number with all requests for parts or service.

Specifications and price change privileges reserved.

Copyright © 1972 by Tektronix, Inc., Beaverton, Oregon. Printed in the United States of America. All rights reserved. Contents of this publication may not be reproduced in any form without permission of Tektronix, Inc.

U.S.A. and foreign TEKTRONIX products covered by U.S. and foreign patents and/or patents pending.

TEKTRONIX is a registered trademark of Tektronix, Inc.

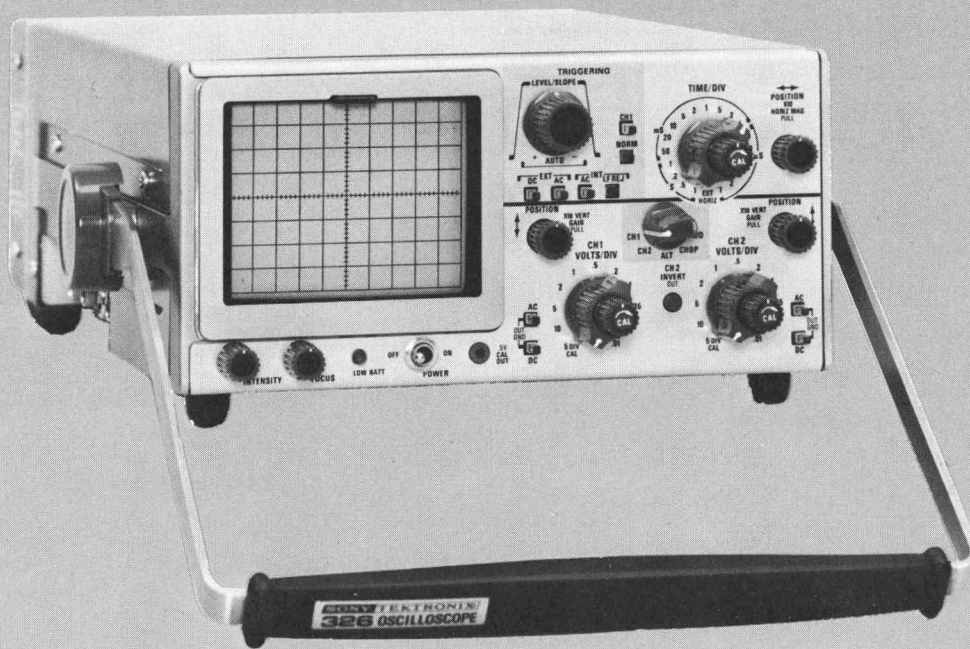

SONY/TEKTRONIX 326 Oscilloscope.

326 SPECIFICATION

Introduction

The SONY/TEKTRONIX 326 Oscilloscope is a solid-state portable instrument that combines small size and light weight with the ability to make precision waveform measurements.

A dual-trace DC to 10 MHz vertical system provides calibrated deflection factors from 0.01 Volt/Div to 10 Volts/Div (0.001 Volt/Div minimum with reduced frequency response).

The trigger circuit provides stable triggering over the full vertical bandwidth. A 300 ns delay line in the vertical system allows the operator to view the portion of the waveform on which triggering occurs.

The horizontal deflection system provides calibrated sweep rates from 1 μ s/Div to 1 s/Div. A 10X magnifier extends the sweep rate to 0.1 μ s/Div.

The 326 can be operated from internal battery, an external DC source, or from the AC line (with battery charger attached).

The following electrical characteristics apply over an ambient temperature range of +20°C to +30°C (+68°F to +86°F). Warmup time for the accuracies given is approximately 10 seconds.

CHARACTERISTICS

VERTICAL AMPLIFIER

Deflection Factor

Ranges: 10 mV/Div to 10 V/Div in X1 Gain and 1 mV/Div to 1 V/Div in X10 Gain. 10 steps in a 1-2-5 sequence. Accuracy within 3% over the calibrated range.

Variable: Variable between calibrated deflection factor settings. Extends the highest deflection factor to at least 25 V/Div.

Attenuator Compensation: +1%, -1%, or less, 0°C to +55°C (+32°F to +131°F). +2%, -2%, or less, -15°C to 0°C (+5°F to +32°F).

Frequency Response

Bandwidth (Variable Volts/Div at CAL, 5 division reference) direct coupled: 1X Gain, DC to at least 10 MHz (upper -3 dB point) with the P6049A Probe. Capacitively coupled, 4 division reference: from 10 Hz or less (lower -3 dB point) at all deflection factors. 1 Hz or less with the P6049A Probe.

Step Response (risetime), 4 division step input: 36 ns or less in X1 Gain and 72 ns or less with X10 Gain.

Aberrations: +2%, -2% with total of 4% or less in all modes except ADD ALG. +3%, -3% with total of 6% or less in ADD ALG Mode.

Input

Maximum Voltage: 500 volts direct coupled (DC + peak AC) or capacitively coupled DC voltage.

Resistance: 1 M Ω , within 2%, direct and 10 M Ω , within 2%, with the P6049A Probe.

Capacitance: 47 pF within 4 pF direct and 13.5 pF or less with the P6049A Probe.

Amplifier

Linear dynamic range in Added Mode: Equal to or greater than 8 times the Volts/Div setting for 10% distortion.

Common-Mode Rejection: At least 20:1 at 2 MHz for a common-mode signal of 80 mV peak-to-peak, Volts/Div set at 10 mV and CH 2 set for maximum CMRR at 50 kHz and 10 mV.

DC Drift

With Time (short term): 0.2 div or less during any minute within the first hour after a 10 second warmup (with temperature and line voltage constant).

Specification—326

Chopped Mode

Repetition Rate: 110 kHz within 20%.

Duty Cycle: 40% to 60%.

Resistance: Approximately 10 k Ω .

TIME BASE

Sweep Time/Div

Calibrated Range: 1 s/Div to 1 μ s/Div in 19 steps in a 1-2-5 sequence. 10X magnifier extends the displayed sweep time to 0.1 μ s/Div.

Accuracy, X1 Gain: within 3% over the center eight graticule divisions from 1 μ s/Div to 0.2 μ s/Div, increasing to 4% from 0.5 s/Div to 1 s/Div.

X10 Gain: within 4% over the center eight graticule divisions, 0.5 μ s/Div to 20 ms/Div, increasing to 5% at 0.1 μ s/Div, 0.2 μ s/Div, 0.1 s/Div, and 50 ms/Div.

Variable: at least 2.5:1.

Trigger

Internal: DC to 10 MHz on signals causing 1.0, or more, division of vertical deflection and to approximately 1.0 MHz on signals causing 0.3 division of vertical deflection.

External: DC to 10 MHz on signals of 500 mV or more, decreasing to approximately 1.0 MHz on signals of 150 mV.

Coupling: AC attenuates signals below 30 Hz; LF REJ attenuates signals below 50 kHz.

External Level Range: Atten at X1, +0.8 V to -0.8 V; Atten at X10, +8 V to -8 V.

Maximum Input Voltage: 300 V (DC + peak AC).

CALIBRATOR

Output

Voltage Accuracy (into a load of 1 M Ω or greater): 0.5 V, within 1% from +20°C to +30°C (+68°F to +86°F), decreasing to within 2% from -15°C to +20°C (+5°F to +68°F) and +30°C to +55°C (+86°F to +131°F).

EXTERNAL HORIZONTAL INPUT

Deflection Factor

Horiz Mag X10, Ext Atten 1X: 15 mV/Div to 25 mV/Div.

Horiz Mag off, Ext Atten 1X: 150 mV/Div to 250 mV/Div.

Horiz Mag X10, Ext Atten 10X: 150 mV/Div to 250 mV/Div.

Horiz Mag off, Ext Atten 10X: 1.5 V/Div to 2.5 V/Div.

Bandwidth

DC to at least 200 kHz (upper -3 dB point).

Dynamic Range

At least 20 divisions (+2.5 volts to -2.5 volts) with EXT TRIG OR HORIZ ATTEN switch set to X10, and EXT HORIZ Variable control set to CAL.

Variable Range

At least 10:1.

EXTERNAL BLANKING

Sensitivity

DC Coupled: +5 volts to +20 volts.

Usable Frequency Range

To approximately 100 kHz.

Input Voltage

Maximum: 50 V (DC + peak AC).

CRT DISPLAY**Graticule Area**

8 X 10 one-fourth inch divisions.

Geometry

Within 0.1 division.

POWER SOURCE**Power Line**

Voltage Ranges (Battery Charger): 90 V to 136 V and 180 V to 272 V.

Frequency (Battery Charger): 48 Hz to 440 Hz.

Maximum Power Consumption: 35 VA, with 136 volt AC line, a 10 MHz 6-division signal displayed, full intensity, and full charge rate.

External DC

Voltage Range: +9 V to +32 V.

Maximum Power Consumption: 12 watts, with 10 MHz, 6-division signal displayed and full intensity.

INTERNAL BATTERY SUPPLY**Battery**

9 size C, 1.5 AH NiCd cells.

Charge Time

Full Charge (instrument off): at least 16 hours.

Operating Time, +20°C to +25°C (+68°F to +77°F) charge temperature and +10°C to +30°C (+50°F to +86°F) operating temperature:

15 μ A or less cathode current

Calibrator Waveform displayed: 4 hours or greater.

6 divisions of 10 MHz signal displayed: 1.8 hours or greater.

315 μ A cathode current (full intensity)

Calibrator waveform displayed: 2.5 hours or greater.

6 divisions of 10 MHz signal displayed: 1.5 hours or greater.

ENVIRONMENTAL**Temperature**

Nonoperating: -40°C to $+75^{\circ}\text{C}$ (-40°F to $+167^{\circ}\text{F}$).

Operating: -15°C to $+55^{\circ}\text{C}$ ($+5^{\circ}\text{F}$ to $+131^{\circ}\text{F}$).

Charging: 0°C to $+40^{\circ}\text{C}$ ($+32^{\circ}\text{F}$ to $+104^{\circ}\text{F}$).

Altitude

Nonoperating: to 50,000 feet.

Operating: to 15,000 feet. Maximum allowable ambient temperature decreases by $1^{\circ}\text{C}/1000$ feet from 5,000 feet to 15,000 feet.



OPERATING INSTRUCTIONS

General

This section explains power source requirements, describes the functions and uses of controls and connectors, and gives first time and general operating information.

POWER SOURCE REQUIREMENTS

General

The 326 may be powered from either the internal Battery Pack (nine NiCd cells connected in series) or on an external DC voltage source ranging from +9 volts to +32 volts.

The internal battery pack is removable and may be charged (while in the instrument or externally) by the battery charger.

Typical operating time from a fully charged battery pack is approximately 4 to 5 hours. Actual operating time varies with sweep rate, the displayed signal frequency and amplitude, display brightness, and the ambient temperature during cell charge.

Internal Battery Operation

Sliding the power source switch to the BATT OR AC ADPT position connects the internal battery to the 326 front-panel POWER switch. Internal battery powered operation is not possible with the source switch in the EXT DC POWER position.

Internal battery powered operation should be discontinued after the LOW BATT lamp starts flashing. The battery should immediately be put on charge or the battery pack should be replaced with a fully charged pack.

If the internal battery-powered operation is continued after the LOW BATT lamp starts flashing, the trace will disappear in a short time and the LOW BATT lamp will stop flashing; damage to some of the NiCd cells might result.

If the cells must be removed from the battery pack, use the following procedure:

WARNING

The cells used in the battery pack are capable of delivering a large amount of energy in a short time. Rings, watch bands and other metallic items that might short circuit the battery can rapidly become hot enough to cause severe burns.

Cell Removal (see Fig. 2-1)

1. Remove the three machine screws from the left edge of the Battery Pack front panel.
2. Remove two machine screws from the rear (same edge as those removed from the front) panel.

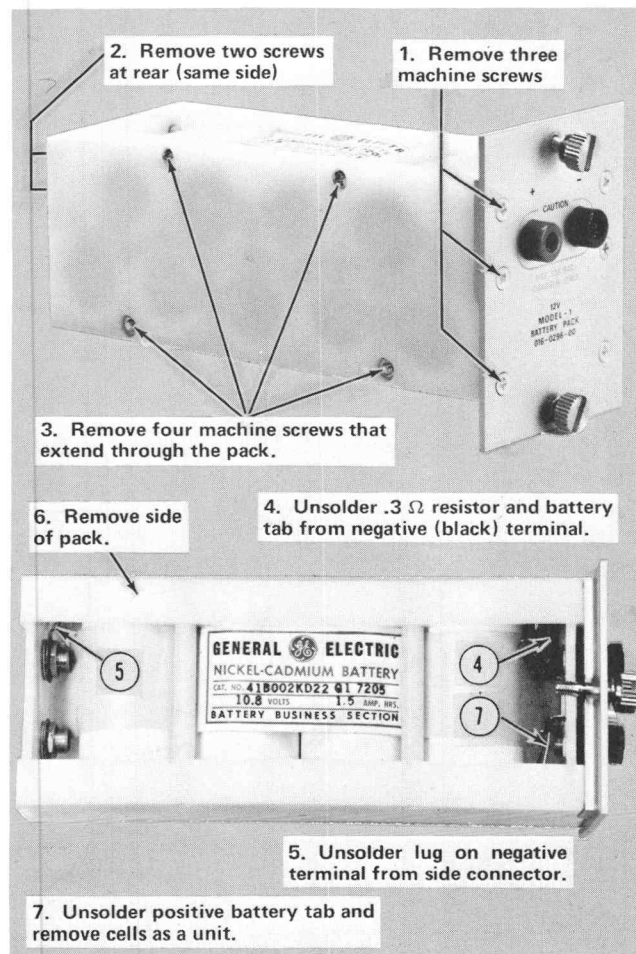

Fig. 2-1. Battery Pack cell removal.

Operating Instructions—326

3. Remove the four machine screws that extend through the pack.
4. Carefully unsolder the copper strap and bare wire from the connector lug at the front end.
5. Unsolder connector lug from side-panel conductor at the rear of the pack.
6. Lift the side away from the pack.
7. Unsolder the copper strap from the negative connector lug.
8. Carefully lift the cells (as a unit) away from the case. Do not allow the copper cell tabs to contact each other while removing cells.

External DC-Powered Operation

The instrument can be powered by an external DC source between +9 and +32 volts. The Power Source switch must be in the EXT DC POWER position and the external supply must be connected to the + (red) and - (black) connectors on the rear panel of the instrument. The external DC source will not charge the internal battery.



Applying external DC power with the polarity reversed will cause the Power Regulator fuse, F870 on the Horizontal circuit board, to open.

Battery Charger

The internal battery pack may be charged either within or outside the instrument. When charging the battery pack inside the instrument the battery charger attaches to the rear of the instrument.

Instrument operation can be continued while the internal battery is charging or a spare battery pack can be charged while the instrument operates on internal battery.

The battery pack may be charged in the instrument while the instrument is operating on an external DC source.

Slip-on connectors in the battery charger must be connected to match the line voltage to be used. The internal fuse must be changed when the AC line voltage is changed. Use a 0.4 A fuse for 115-volt operation and a 0.2 A fuse for 230-volt operation. See Fig. 2-2.

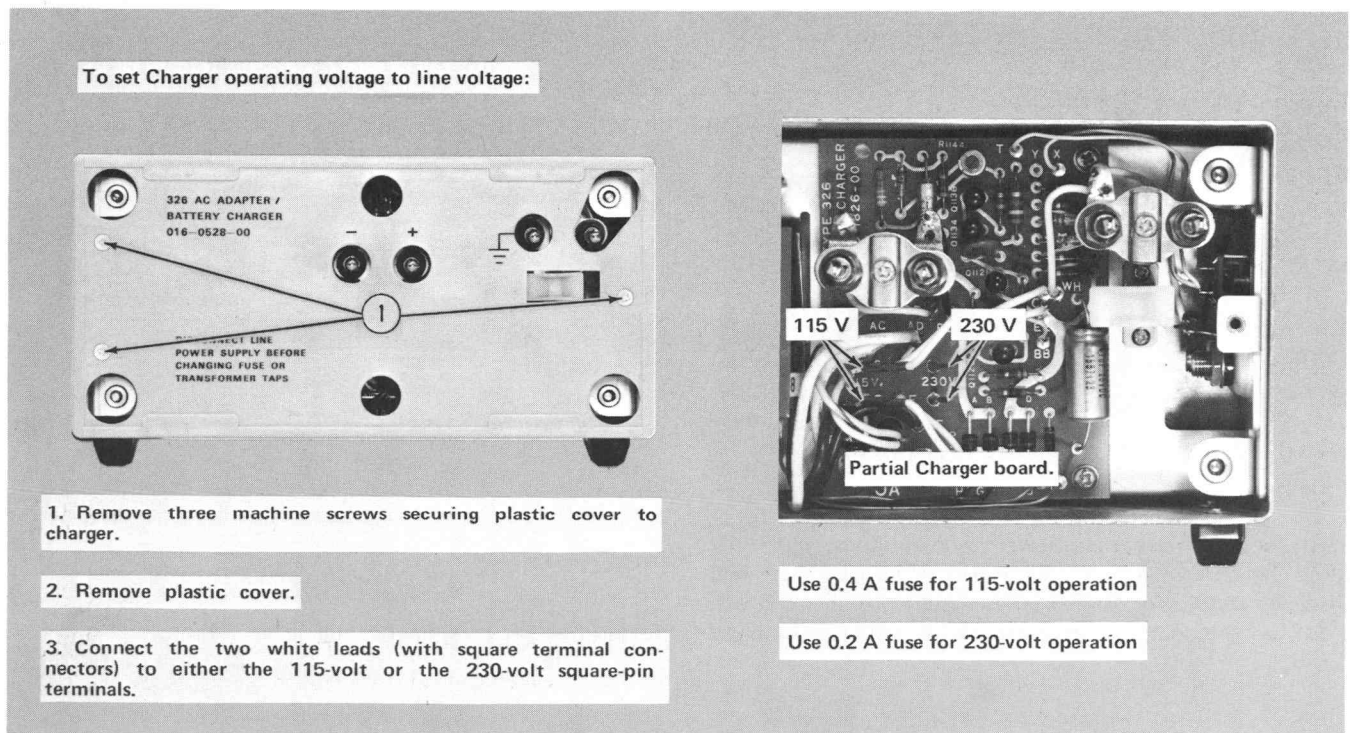

Fig. 2-2. Location of line-voltage selection terminals.

Battery Charging

Although the battery contained in the 326 is charged before packaging, it should be recharged for 16 hours at FULL CHG rate before being put into service.

The charging characteristics of NiCd cells vary with cell temperature during charge. The energy delivered is inversely proportional to the cell temperature during the first three-fourths to seven-eighths of the full charge cycle.

If NiCd cells become reverse charged, their capacity for recharging can be impaired or destroyed. An imbalance between cells in a battery can develop during operation or during partial charging. It is possible for the imbalance to become so great that during discharge the weakest cells completely lose their charge and become reverse charged by the current from the charged cells.

To avoid reverse charging one or more cells, fully charge the battery after each discharge (16 hours) on FULL CHG. Although partial recharge is not recommended as a common practice, occasional recharges can be tolerated. About 30 to 45 minutes of operating time can be expected for each hour of charge.

In addition, the battery should be charged at the FULL CHG rate for 24 hours approximately once a month or

every 15 charge/discharge cycles. Once the battery has been fully charged, the charge rate should be set to TRICKLE. The trickle charge rate provides only enough current to offset the internal losses, and will keep the battery fully charged.

FUNCTION OF EXTERNAL CONTROLS, CONNECTORS AND INDICATORS

General

The controls, connectors, and indicators listed are contained on the external surfaces of the 326, and are used during routine oscilloscope operation. All other controls are inside the instrument covers and should be adjusted only during instrument calibration.

The external control, connector, and indicator nomenclature is shown in CAPITAL letters wherever it appears in this manual.

Front Panel (see Fig. 2-3)

POWER ON-OFF Two position toggle switch. Connects the oscilloscope circuitry to the power source.

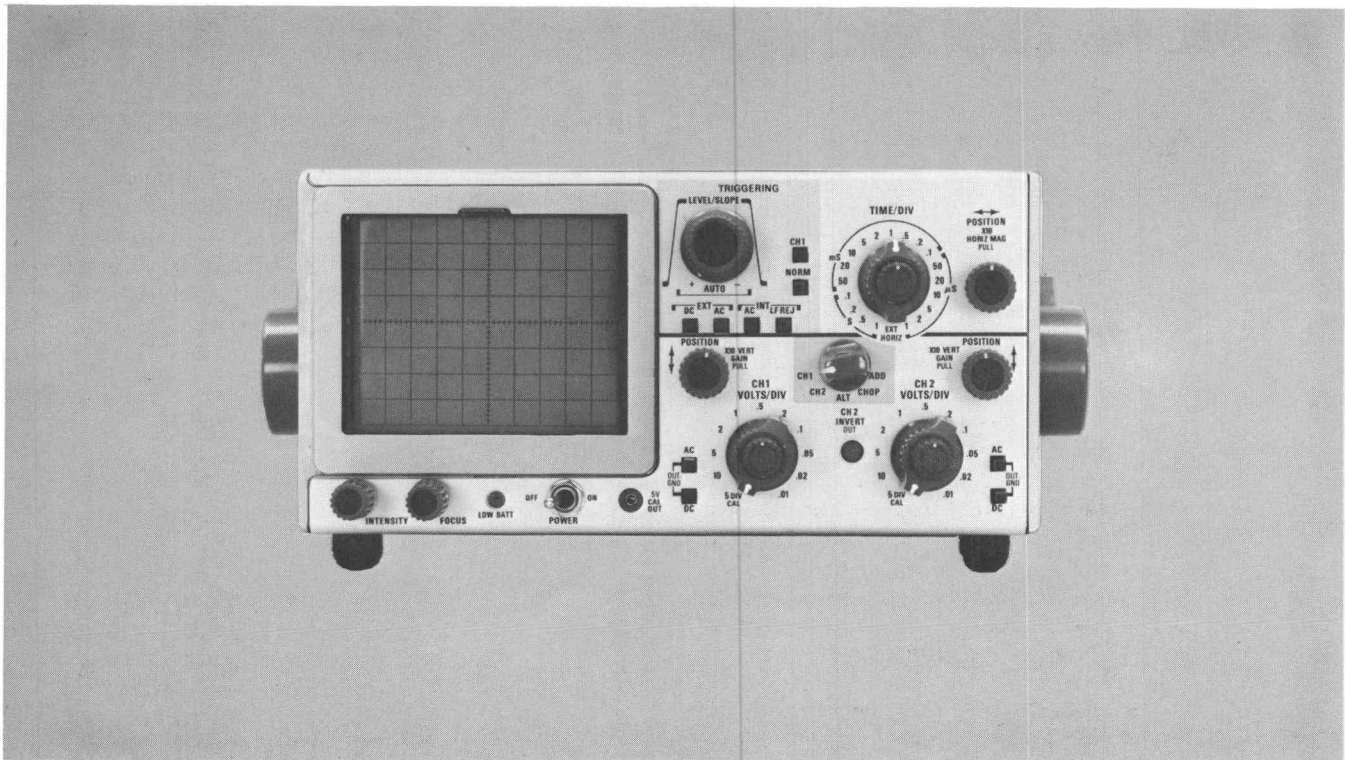

Fig. 2-3. 326 Front panel.

LOW BATT Indicator lamp. During battery operation, the lamp flashes to indicate that internal battery voltage is low. If the battery voltage is sufficiently low the lamp will stop flashing and the instrument will stop operating. To distinguish this condition from equipment failure, connect the charger at FULL CHG rate for a few minutes. Then disconnect the charger and check for oscilloscope operation and LOW BATT indicator lamp operation.

CH 1 VOLTS/DIV Selects calibrated deflection factors from 0.1 Volts/Div to 10 Volts/Div (Variable in CAL position and X10 GAIN pushed in). When set to the 5 DIV CAL position, a 5-division square-wave calibrator signal is displayed.

Variable Varies Volts/Div between calibrated steps. Range is at least 2.5X. The uncalibrated range is extended to 25 Volts/Div.

CH 1 Input Coupling Switch

AC Capacitively couples the input signal to the input attenuator.

GND Grounds the input attenuator (both pushbuttons out) and connects the signal through 470 k Ω and 0.0185 μ F to ground.

NOTE

The GND configuration (both AC and DC buttons out) provides a precharge circuit. The input coupling capacitor charges to the DC level of the input signal. This precharge feature prevents offscreen deflection which occurs when connecting a signal to the input with the AC button pushed. Always use the precharge feature before connecting the signal to the input (with both buttons out, connect the signal to the input and then push the AC button).

DC Couples the input signal directly to the input attenuator.

Vert Position Vertically adjusts the display position.

X10 GAIN Pull the POSITION control knob to increase the vertical gain by a factor of 10. Extends the calibrated deflection factor to 1 mV/Div. Bandwidth is reduced to 5 MHz.

CH 2 VOLTS/DIV, Variable, input coupling switches, POSITION and X10 GAIN provide the same functions as those of CH 1.

Mode Selector

CH 1 Displays channel 1 only.

CH 2 Displays channel 2 only.

ALT Displays channel 1 and channel 2 alternately. When both channels are displayed, the channels are switched electronically during beam retrace interval.

CHOP Displays channel 1 and channel 2 simultaneously.

ADD Displays the algebraic sum of the signals applied to channels 1 and 2.

CH 2 INVERT Channel 2 display is inverted with the INVERT switch in the OUT position.

TIME/DIV Selects the horizontal sweep rate. Sweep rates are 1 μ s/DIV to 1 s/DIV in a 1-2-5 sequence, plus an EXT HORIZ position. In the EXT HORIZ position horizontal deflection depends on signal applied to the EXT HORIZ INPUT connector on the side panel.

NOTE

For external sweep, the EXT Trigger Selector button must be pushed.

Variable Varies the TIME/DIV between calibrated steps. Range is at least 2.5X. The uncalibrated sweep rate is extended to 2.5 s/Div. With the TIME/DIV selector in the EXT HORIZ position, the Variable control attenuates the external horizontal signal from 1X to 10X.

POSITION X10 HORIZ MAG Horizontally positions the display. Pull the POSITION X10 HORIZ MAG knob to increase the horizontal gain by a factor of 10 (the sweep expands from graticule center). X10 magnification extends the fastest displayed sweep rate to .1 μ s/DIV.

EXT (pushbuttons) Triggers the sweep from a trigger signal applied to the EXT HORIZ INPUT (side panel).

AC Capacitively couples the external trigger signal. Low frequency cutoff is about 30 Hz.

DC Triggers on DC level changes as well as AC signals.

INT (pushbuttons) Triggers the sweep on the signal applied to the Vertical Input(s).

AC Capacitively couples the internal trigger signal. Low frequency cutoff is about 30 Hz.

LF REJ Capacitively couples the internal trigger signal. Makes high frequency triggering more dependable by rejecting frequency components below about 50 kHz.

CH 1-NORM (pushbuttons) Selects the internal triggering source. NORM button selects an internal signal, dependent on the position of the Mode switch. CH 1 button selects Channel 1 only as the trigger source.

LEVEL/SLOPE Selects the level and slope of the displayed signal on which triggering occurs. In the fully ccw position, triggering is automatic on the positive-going (+) trigger signal. In the fully cw position, triggering is automatic on the negative-going (-) triggering signal. Between the two extreme positions the control selects the triggering level on either the + or - slope. AUTO triggering provides a baseline in the absence of triggering signal, but triggering is normal on recurrent signals.

INTENSITY Adjusts the display brightness. Display brightness affects battery operating time.

FOCUS Adjusts for a sharp, well defined trace. Interacts somewhat with the INTENSITY control.

LOW BATT Indicator light flashes when battery needs recharging. Does not flash when battery is completely discharged.

POWER OFF-ON Switches power to the oscilloscope circuits. Does not affect battery charging.

.5 V CAL OUT Source of calibration square wave. 0.5 volts, peak to peak.

Side Panel

EXT TRIG OR HORIZ INPUT Apply external trigger or external horizontal input signal to this BNC connector.

ATT X1-X10 Switch Selects attenuation factor (X1 or X10) for the external signal.

INSTRUMENT FAMILIARIZATION

This procedure provides a means of quickly checking the operation of the 326.

Preliminary

Preset the front-panel controls as follows:

| | |
|-------------------|-----------|
| LEVEL/SLOPE | +AUTO |
| AC-LF REJ | AC |
| CH 1-NORM | CH 1 |
| TIME/DIV | 1 ms |
| Variable | CAL |
| Horiz POSITION | midrange |
| X10 HORIZ MAG | pushed in |
| Mode | CH 1 |
| CH 1 and CH 2 | |
| VOLTS/DIV | 5 DIV CAL |
| Variable | CAL |
| Input AC-DC | DC |
| Vertical POSITION | midrange |
| X10 GAIN | pushed in |
| INTENSITY | midrange |
| FOCUS | midrange |

Set rear-panel EXT DC POWER-BATT OR AC ADPT switch to BATT OR AC ADPT.

1. Check Battery Charge Level

- a. Switch POWER switch to ON.

b. CHECK—The LOW BATT Indicator should not flash.

c. If LOW BATT Indicator flashes, charge the battery pack, replace the battery pack with a fully charged pack, or operate on an external DC supply. Proceed with the checkout.

d. The lower portion of the calibrator signal should appear within the graticule area. Adjust FOCUS and INTENSITY for suitable viewing. Vertically position the bottom of the display to the bottom graticule line. Horizontally position the start of the display to the first graticule line (left).

2. Check Vertical Deflection Factor

a. CHECK—The amplitude of the displayed square wave should equal 5 divisions.

b. Pull out the CH 1 X10 VERT GAIN control knob.

c. CHECK—The display amplitude should equal 5 divisions.

3. Check Probe Compensation

a. Connect a P6049A Probe to the CH 1 VERT INPUT connector. Set CH 1 VOLTS/DIV selector to .01 V, TIME/DIV to 1 ms, and Mode to CH 1.

b. Touch the probe tip to the CAL OUT jack and check the display for proper probe compensation (see Fig. 2-4).

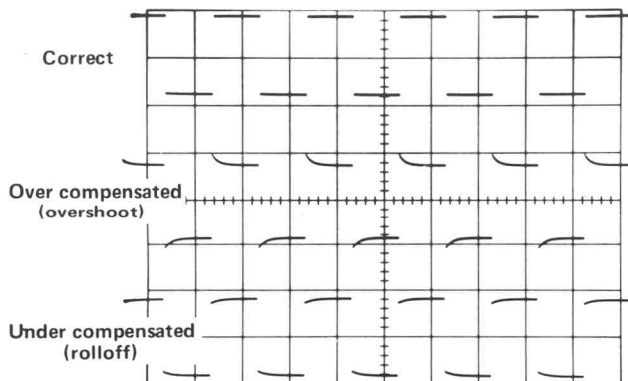

Fig. 2-4. Probe Compensation.

c. If necessary, adjust the probe compensation for the best front corner response to the square waves as shown in Fig. 2-4.

4. Check Trigger Sensitivity and Polarity

a. Set CH 1 VOLTS/DIV selector to 1 volt, TIME/DIV to 1 ms, push INT AC and CH 1 buttons. Pull out the CH 1 X10 VERT GAIN control and apply the CAL OUT signal to CH 1 VERT INPUT and to EXT TRIG OR HORIZ INPUT by means of patch cords.

b. Adjust the CH 1 VOLTS/DIV Variable control for a 3-division display amplitude.

c. CHECK—For stable triggering on the + slope and on the - slope of the displayed signal (turn the LEVEL/SLOPE control throughout its range and check for proper triggering). Check for stable triggering in both + AUTO and - AUTO.

d. Connect the CAL OUT signal to CH 2. Switch CH 2 VOLTS/DIV to 1 V, Mode to CH 2, and CH 1-NORM to NORM.

e. Adjust the CH 2 VOLTS/DIV Variable control for a 3-division display amplitude.

f. CHECK—For stable triggering on the + slope and on the - slope of the displayed signal, including the + AUTO and - AUTO positions.

g. Reconnect the CAL OUT signal to both CH 1 VERT INPUT and EXT TRIG OR HORIZ INPUT.

h. Switch Mode to CH 1, TRIGGERING to EXT AC, CH 1-NORM to CH 1.

i. CHECK—For stable triggering on the + slope and - slope, including the + AUTO and - AUTO positions.

5. Check External Horizontal

NOTE

In the Ext Horiz mode, the internal sweep is disabled and the CRT beam is unblanked. Consequently, a brighter than normal stationary spot will appear on the CRT face unless an external sweep is applied. The INTENSITY setting should be changed to reduce the brightness level consistent with good viewing.

- a. Apply the CAL OUT signal to the EXT TRIG OR HORIZ INPUT connector using a patch cord.
- b. Set the EXT TRIG OR HORIZ ATTEN to 1X.
- c. Set the TIME/DIV to EXT HORIZ and TRIGGERING Coupling to EXT AC.
- d. Check for two spots separated by approximately 3 divisions.
- e. Set the EXT TRIG OR HORIZ ATTEN to 10X. Horizontally center the display.
- f. Note that the distance between the two spots decreases by a factor of 10.
- g. Pull the X10 HORIZ MAG. Position horizontally as necessary to keep the display approximately centered.
- h. Note that the distance between spots increases by a factor of approximately 10.

Charging the Battery (Battery Pack out of the Instrument)

Plug the battery charger banana plugs into the battery pack banana jacks, being sure that the polarity is correct (mount the charger in the same position relative to the

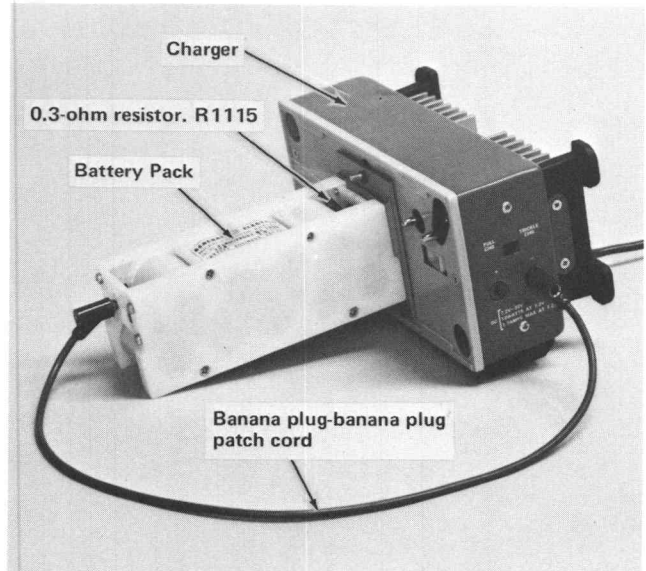

Fig. 2-5. Ground connection required to charge Battery Pack outside of instrument.

battery pack that it would be in if charging the battery pack in the instrument).

Connect a banana-banana patchcord from the negative (gnd) battery pack output terminal to the negative (gnd) external DC supply banana jack. See Fig. 2-5.

Plug the AC power cord into the charger and connect to the power line. Set the FULL CHG—TRICKLE switch to FULL CHG.



CIRCUIT DESCRIPTION

Introduction

This section of the manual contains a description of the circuitry used in the 326 Oscilloscope. A brief description of the instrument block diagram (preceding the foldout circuit schematics) is followed by a somewhat more detailed description of the individual blocks. Since the Power Regulator contains unique circuits, additional detail is provided.

If more information is desired on the commonly used circuits, refer to the following textbooks:

TEKTRONIX Circuit Concepts Books (order from your local TEKTRONIX Field Office or representative).

Cathode Ray Tubes, TEKTRONIX Part Number 062-0852-01.

Horizontal Amplifier Circuits, TEKTRONIX Part Number 062-1141-00.

Oscilloscope Trigger Circuits, TEKTRONIX Part Number 062-1056-11.

Power Supply Circuits, TEKTRONIX Part Number 062-0888-00.

Sweep Generator Circuits, TEKTRONIX Part Number 062-1098-01.

Vertical Amplifier Circuits, TEKTRONIX Part Number 062-1145-01.

Phillip Cutler, "Semiconductor Circuit Analysis", McGraw Hill, New York, 1964.

Lloyd P. Hunter, "Handbook of Semiconductor Electronics", second edition, McGraw Hill, New York, 1962.

Millman and Taub, "Pulse, Digital, and Switching Waveforms", McGraw Hill, New York, 1965.

BLOCK DIAGRAM DESCRIPTION

Instrument Block

The block diagram shows only the basic interconnections between individual blocks (see the foldout Block Diagram preceding the Schematic foldouts at the rear of the manual).

Signals applied to the vertical inputs are applied to the Vertical Preamp through the input coupling selector switch and the input step attenuators.

The Vertical Preamps contain gain, balance, and positioning controls as well as controls for setting the CRT vertical deflection plate DC levels.

A five division calibration signal is introduced into each channel via the input attenuators.

Signal is picked off at channel 1 preamp output for use as triggering signal.

The two vertical channels are switched electronically by the channel switching multi and gating diodes to provide five modes of operation: CH 1, CH 2, ALT, CHOP, and ADD.

Signal is picked off ahead of the delay line to provide trigger signal from whichever signal is being gated through to the output amplifier.

A 300 ns delay line provides sufficient signal delay to the CRT vertical deflection plates to allow observation of the transition which triggers the sweep.

The Output Amplifier provides high frequency compensation, and the current capability to drive the vertical deflection plates.

The Trigger Preamp selects the trigger source and amplifies the signal selected to a level compatible with the trigger generator input.

Circuit Description—326

The trigger source (either the signal from the Trigger Preamp or the EXT TRIG) and the method of coupling are selected in the Trigger Generator. The trigger signal selected is coupled to a DC comparator amplifier to select the point on the signal at which triggering occurs. A switch in the comparator output selects trigger polarity. The signal is then shaped in the Schmitt multi and is coupled to the Sweep Generator to start the sweep voltage runup.

The Sweep Generator is a Miller integrator (runup) which provides a linear sawtooth voltage to the horizontal amplifier. A gate-amplifier circuit provides signal to the CRT to blank the trace during the retrace interval.

The Horizontal Amplifier contains adjustable components to set horizontal X1 Gain, X10 Gain, and positional registration in the magnified mode. The output circuitry provides drive to the CRT horizontal deflection plates.

The Power Regulator derives all of the regulated operating voltages from the DC source voltage (internal battery or external DC source). Adjustments are provided to set the CRT beam accelerating potential, focus, beam intensity, and the + and - 5-volt supply levels.

The Battery Charger circuit provides current either for charging the battery in about 16 hours or a trickle charge which just offsets the internal losses of a fully charged battery. An internal adjustment sets the charge current level.

BASIC BLOCK DESCRIPTION

Introduction

This section describes briefly each of the basic circuits. The description of each block is keyed to the circuit schematic (foldout at rear of manual), i. e., (2) indicates schematic No. 2, CH 1 Vertical Preamplifier.

Ch 1 Vertical Preamplifier (2)

Input Coupling. Determines the method of coupling the signal to the amplifier input (AC—DC—GND).

Attenuators. Conventional frequency compensated step attenuators which maintain the input RC at 1 M Ω and 47 pF in each of the 10 switch positions.

Input. D30 through D33 prevent overdrive to the input FET, Q31A. R36 permits adjustment for any differences in the characteristics of Q31A and Q31B, which are electrically and thermally paired.

The first amplifier stage is a feedback amplifier consisting of the paraphase configuration Q41A and Q41B and the common-base section Q51-Q52 and Q53-Q59. R41 (X10 Vert Gain) adjusts the gain in the X10 switch (S40) position. R37 (Var Volts/Div Bal) adjusts Q41A and Q41B collector loads to prevent display shift as the VOLTS/DIV Variable is rotated throughout its range.

A push-pull emitter follower, Q55-Q57 drives the push-pull amplifier Q61-Q71. X1 Gain calibration and Volts/Div Variable are adjusted in the common-emitter circuit and display vertical position is adjusted in the collector circuits.

Q81-Q91-Q88-Q99 is a push-pull feedback amplifier in which the upper and lower deflection plate DC levels are adjusted.

Q95 and Q98 supply CH 1 signal to the triggering selector circuit.

Calibrator (shown on schematic (1)). The calibrator (an astable multi, Q1 and Q9, and a precision voltage divider) provide a 0.5-volt square wave to the front-panel CAL OUT jack, and to the Input FET via the 5 DIV CAL position of each (CH 1 and CH 2) attenuator switch.

CH 2 Vertical Preamplifier (diagram (4)). Same as CH 1 Vertical Preamplifier except for Trigger Pickoff and Calibrator.

Vertical Switching and Output (5). Q333-Q343-Q355, a multivibrator with several operating modes, provides channel switching by gating the signal through the appropriate diodes in the switching matrix (D311 through D313 and D315 through D318). The operating modes (selected by the Mode switch) are:

CH 1. +5 volts is applied to Q333 base divider resistor, R342, and to D316-D317, blocking CH 2, gating only CH 1 through to the Output Amplifier.

CH 2. Applies +5 volts to Q343 base divider resistor, R332, and to D311-D312, blocking CH 1, gating only CH 2 through to the Output Amplifier.

CHOP. Applies +5 volts to the junction of R335-R345. The switching circuit operates as an astable (free running) multi at a 110 kHz rate, alternately gating CH 1 and CH 2 into conduction. Since the switching rate is fixed (not dependent on trigger signal) both signals are displayed simultaneously on the viewing screen. A signal is taken

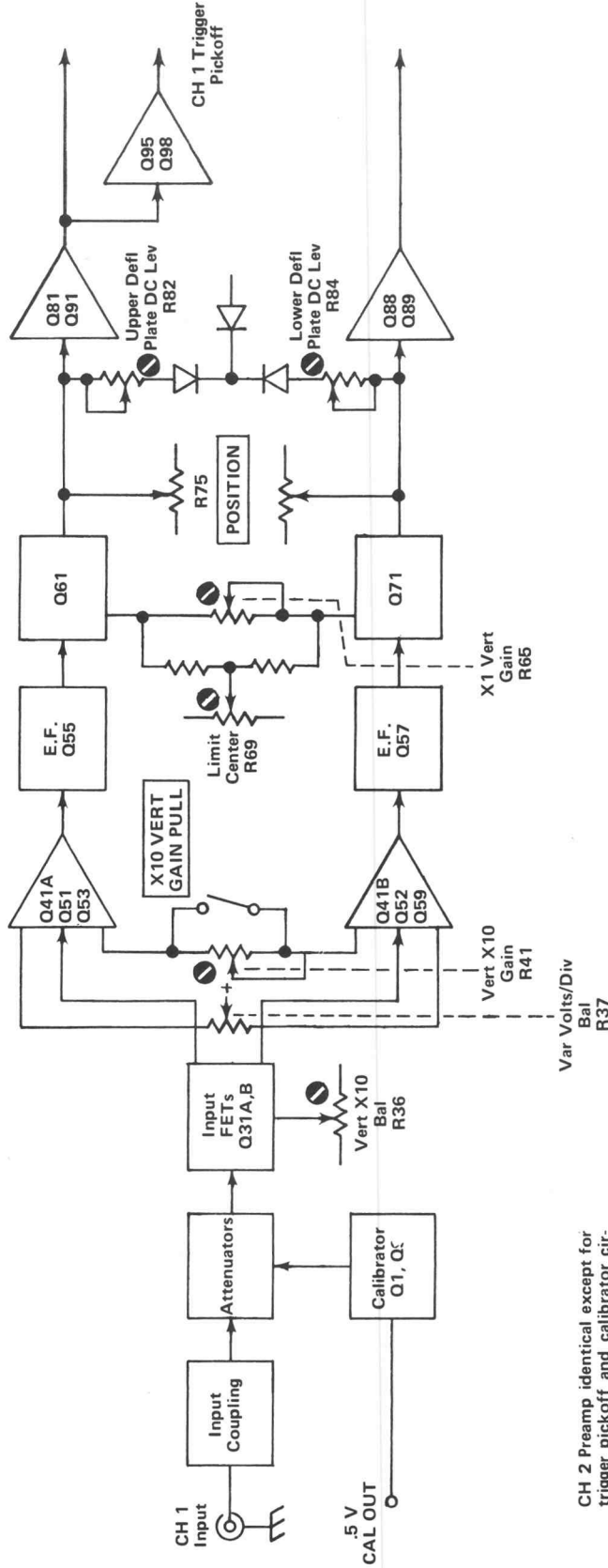

CH 2 Preamp identical except for trigger pickoff and calibrator circuits.

CH 1 Vertical Preamplifier (2)

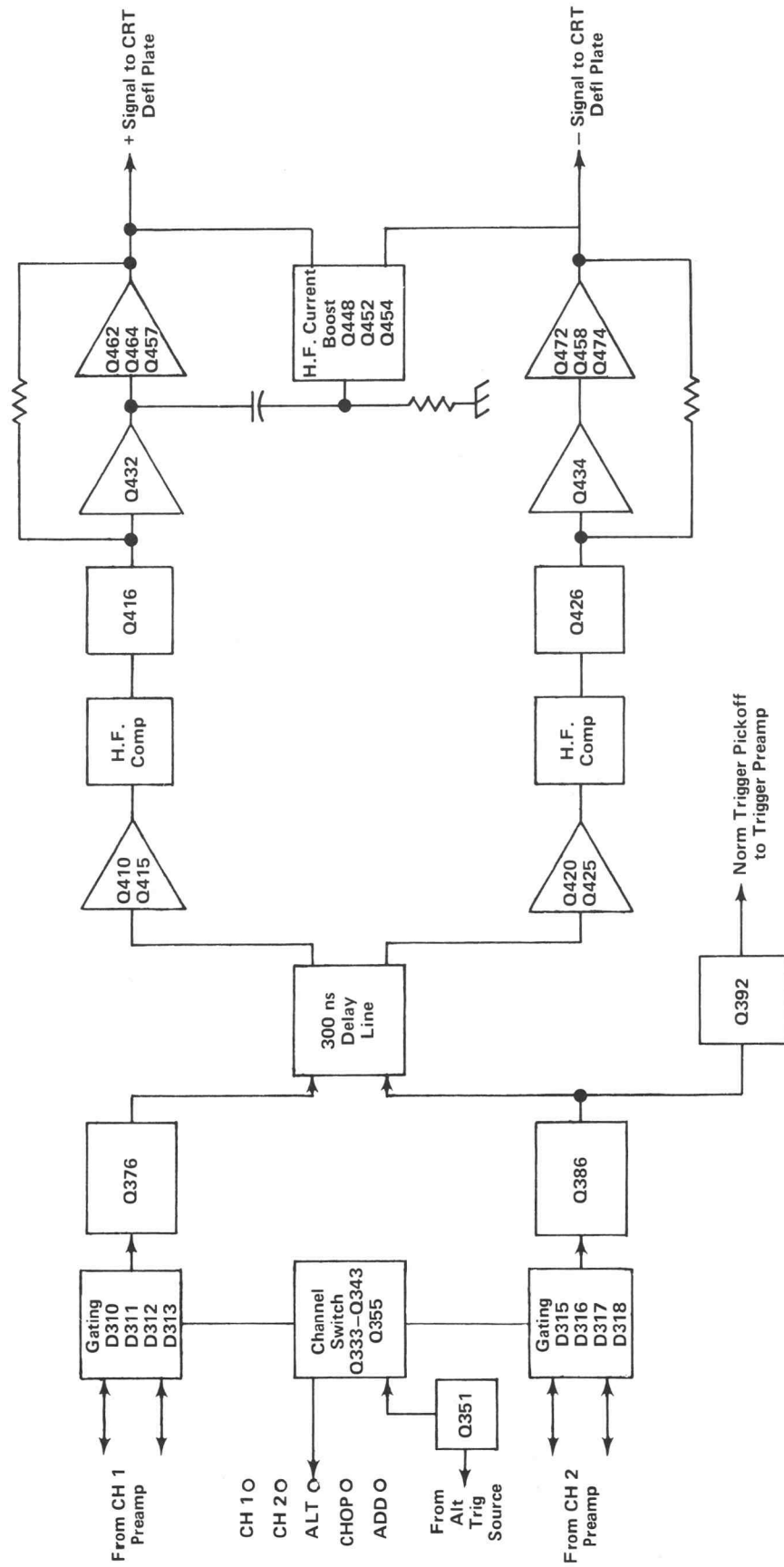

Vertical Switching and Output Amplifier (5)

from the junction of C335-C345, amplified in Q361, and fed to the blanking circuit via D668, (7), to blank the CRT beam during the switching interval.

ALT. Collector voltage supply is connected to Q351 via R350. Trigger signal from the Alt Trigger Source, (6), is connected to the steering diodes, D335 and D345. The channel switched on depends on the last previous condition of the multi (which side was turned on). Each incoming trigger switches the multi, turning one set of channel switching diodes on and turning the other set off. Channel 1 and Channel 2 are displayed alternately.

ADD ALG. +5 volts is applied to the junction of R370-R380, gating both channels through to the Output Amplifier, displaying the algebraic sum of the two signals.

The amplifier following the gating is a common-base pushpull amplifier (Q376-Q386) driving the 300 ns delay line. Norm trigger is picked off at Q386, amplified in Q392 and fed to the Trigger Source switch, (6).

The feedback amplifier Q410-Q415, Q420-Q425, is followed by the high frequency compensation network. Common-base stage Q416-Q426 feeds the Output feedback amplifier, Q432-Q457-Q462-Q464 and Q434-Q458-Q472-Q474.

Amplifier Q448-Q452-Q454 provides deflection plate current boost for high frequency signals.

Trigger Preamplifier. Trigger source (CH 1 ONLY or NORM) is selected by S500, amplified by feedback amplifier Q505-Q505, and fed to the Trigger Generator, (6).

Trigger Generator. S540 (TRIGGERING SOURCE-COUPLING) selects trigger from either the Trigger Preamplifier, (6), or the EXT TRIG OR HORIZ INPUT connector (side panel). Signal is passed via a voltage limiting network to FET Q545, through switching (part of Trigger and part of TIME/DIV switches) and fed to a DC comparator amplifier, Q552-Q556, where the incoming trigger signal is compared to a DC level to set the point on the trigger signal at which triggering occurs. Trigger polarity is determined by the position of the switch in the collector circuits of Q552-Q556.

Q570 and Q580, a Schmitt multi shapes the trigger signal (square wave out) which is differentiated at the Sweep Generator, (7), input.

Trigger switch S560 also switches in the appropriate components to cause the trigger generator to act as a free running multi in the AUTO position of the LEVEL/SLOPE control. The free running multi provides a trace in the absence of trigger signal.

Unblanking and Sweep Generator. Differentiated trigger signal, applied to the trigger gating circuit, Q611-Q630-Q636-Q638-D620-D640-D628, provides signal to gate the Miller Integrator, (7).

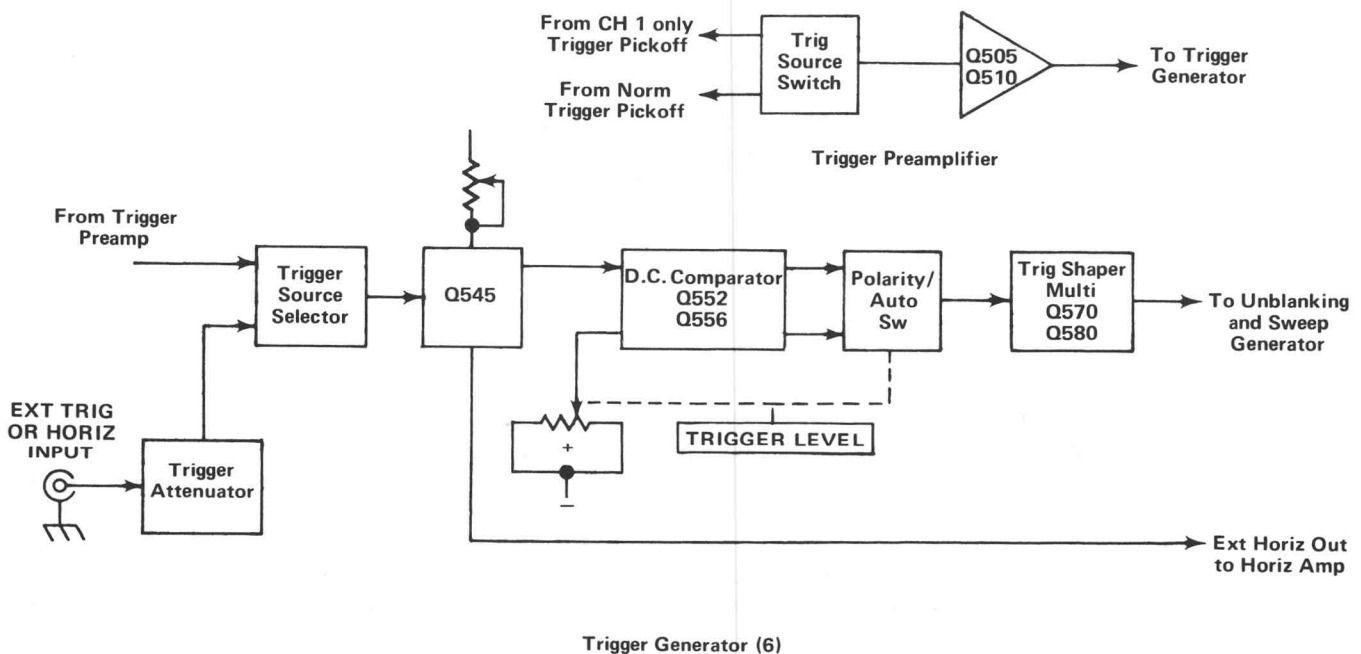

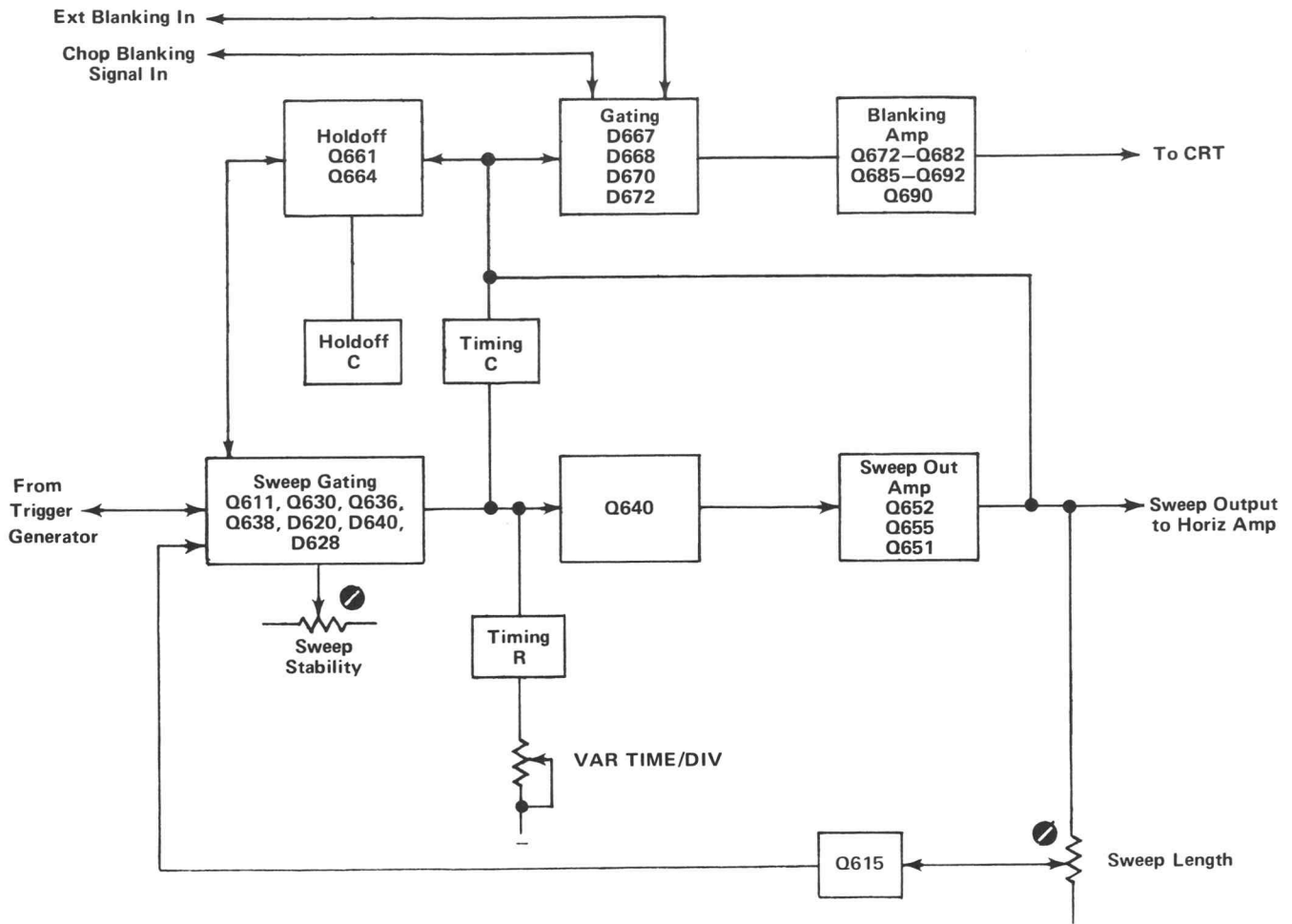

Unblanking and Sweep Generator (7)

Output from the Miller runup is amplified in the Sweep Output Amplifier. The output signal is fed back to Q640 through the timing capacitor and timing resistor to set the sweep rate. Output is also fed back via the sweep length control, R618, to the gating circuit to end the sweep. The output also supplies signal to the holdoff circuit, Q611-Q664, to block incoming trigger signals until the sweep has ended and the sweep circuitry ready to start another sweep.

Blanking signal is selected from one of three points; sweep output, EXT BLANK connector, or from the chopped blanking signal from the Vertical Switching circuit, (5).

The blanking circuit, Q672-Q682-Q685-Q692-Q696, provides CRT beam blanking during retrace and during switching interval in Chopped Mode.

Horizontal Amplifier. Signal from either the Sweep Output, (7), or External Horizontal input is selected by the TIME/DIV switch. The input selector circuit contains adjustments for Sweep Start, Sweep Linearity, and Sweep Cal, (9).

The feedback amplifier Q726-Q732-Q738-Q740, contains components in the feedback loop to set the X10 Mag Gain and X10 Mag Registration. R708 adjusts horizontal display position.

Common-base amplifier, Q741, drives the inverter, Q744-Q746, which drives the Output amplifiers, Q756-Q758-Q748 and Q770-Q772-Q778.

Power Regulator Circuit. DC is supplied to the regulator through the ON-OFF switch and fuse, F870.

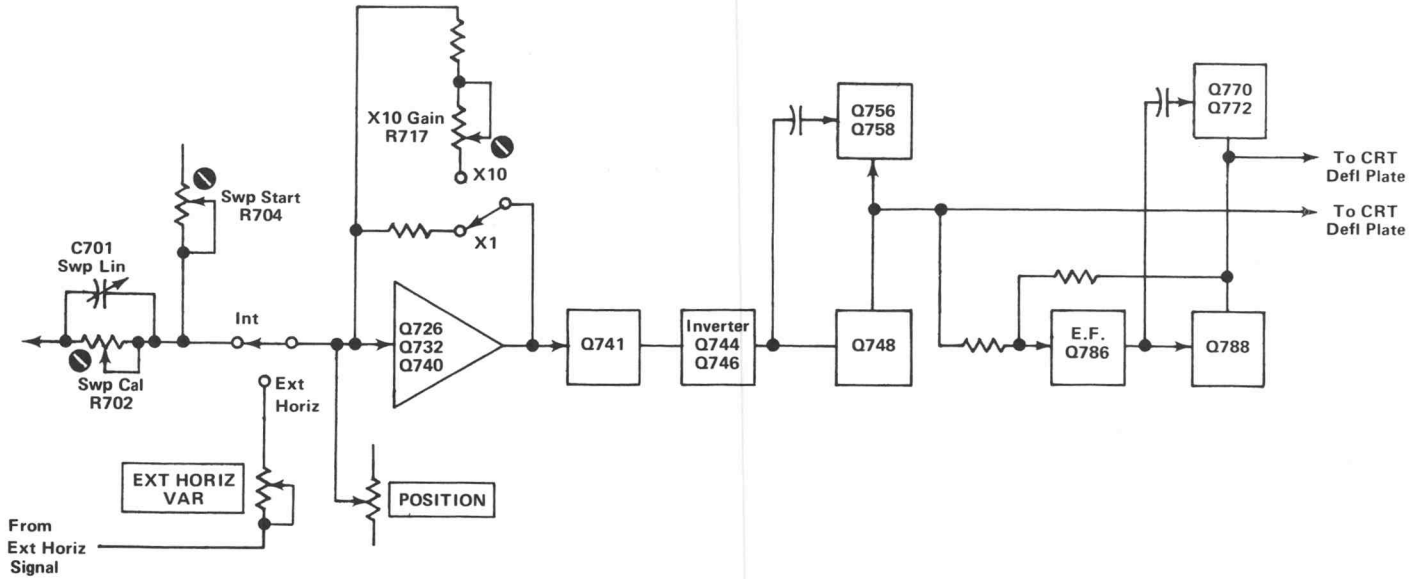

Horizontal Amplifier (9)

A low battery voltage indicator circuit flashes the front-panel LOW BATT lamp when the applied DC level drops below +7.2 volts.

The start circuit supply provides operating potential to the start multi until the power supply is operating.

Initially, the start multi provides a pulse to the turn-on circuit, which provides turn-on bias to the current driver circuit, gating current into T970 transformer primary. The current in T980 primary produces a secondary voltage which is connected to the turn-off circuit. When the T980 secondary current reaches a predetermined level the turn-off circuit reverse biases the current driver, rapidly termi-

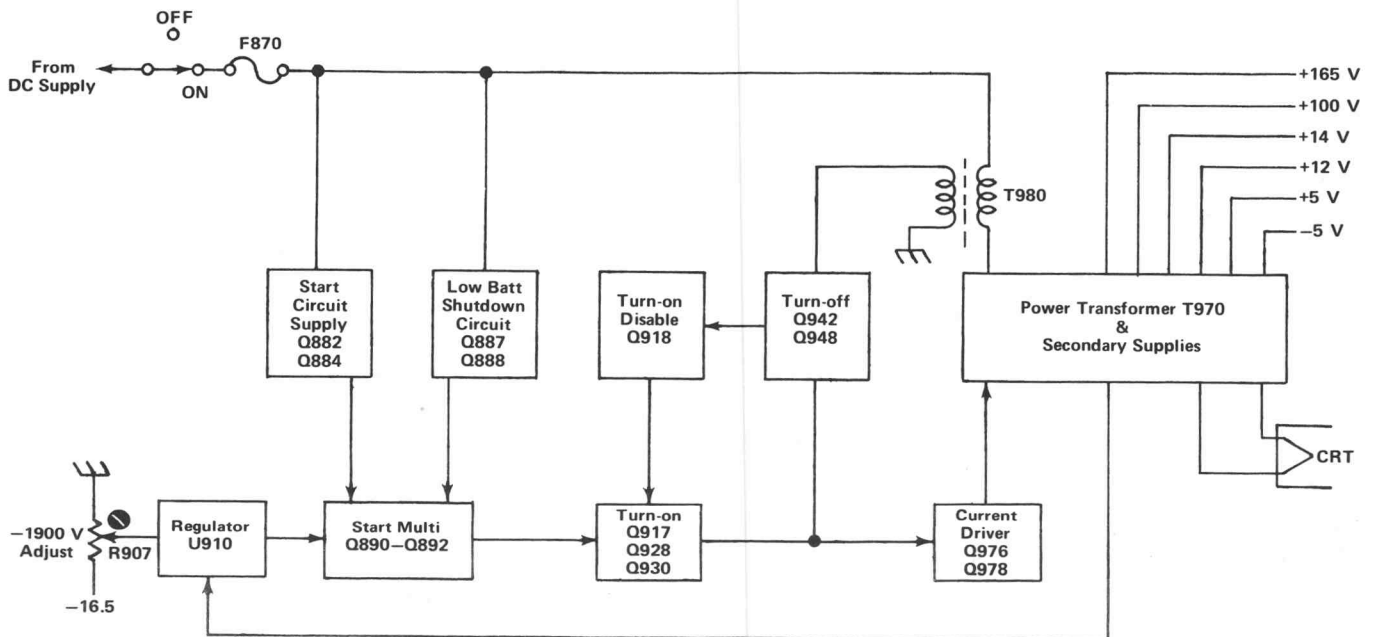

Power Regulator (10) (11)

Circuit Description—326

nating current in T970 and T980 primaries. At the same time a pulse is connected to the turn-on disable circuit which removes the turn-on signal to the current driver.

The next pulse from the start multi again starts the current buildup sequence.

Regulation is achieved by controlling the length of time that current is gated to T970 primary. The turn-on time is determined by the pulse repetition rate of the start multi, which is a function of the start multi collector supply voltage. The start multi collector supply levels are set by U910 (pin 6). The level at pin 6 is determined from two sources: a -16.5-volt DC supply (transformer secondary) to a variable divider, R907, and a sample of voltage from a section of the high voltage supply (transformer secondary).

Any attempted change of the output voltage (transformer secondary) causes the level at pin 6 (U910) to change, causing a change in start circuit multi switching rate, thus changing the transformer (T970) primary current duration, correcting the output voltage.

Once the supply output has come up to normal operating levels, the start circuit supply is reverse biased and T970 secondary supplies assume the regulator load.

In the event that the supply battery voltage drops to too low a level, the low battery shutdown circuit clamps one side of the start multi, turning off the current drive to T970 primary, thus shutting down the supply.

Detailed Regulator Description (10) (11)

D880 limits Zener current in D882 over the wide range of acceptable supply voltages. D882 sets the emitter levels of Q882 and Q884, providing start-up operating potential for the regulator. Once the regulator is functioning normally the start circuit supply is removed from the circuit (D886 and Q884 reverse biased).

Q890, Q892, and associated circuitry, an astable multi provide a negative-going pulse through C892 to the base of Q917, turning Q917 on. Q917 turns on Q928. Q928 turn on produces a positive step at T930 secondary, turning on Q930, providing turn-on bias for the current drivers, Q976 and Q978. At the same time, the positive-going pulse at T930 secondary is fed back through R927 to Q928 base, reinforcing the turn on.

Current builds up in T970 primary, causing voltage buildup in T970 secondaries. Since T980 primary is in series with T970 primary, a voltage builds up across T980

secondary. This secondary voltage forward biases D940, increasing the voltage level at Q942 anode. When Q942 anode comes to within 0.6 volts of Q942 gate level, Q942 turns on, biasing Q948 into saturation, pulling Q976 and Q978 bases toward ground reverse biasing Q976 and Q978, rapidly terminating current in T970 primary.

At the time that Q942 conducts to saturate Q948, a pulse is fed back to Q918, turning Q918 on, cutting off Q928 and Q930, reinforcing the turnoff.

The rapid field collapse in T970 produces the flyback voltage in T970 secondary.

U910, an integrated circuit voltage regulator, controls the voltage applied to the start multi collectors. Two voltages influence the U910 output voltage (pin 6). Variable R907 (with R905 and R909 and the -16.5 volt supply) connected to U910 inverting input adjust the supply output secondary level (secondary voltages).

A sample of voltage picked off of one section of the high voltage supply is fed back to U910 non-inverting input.

Both of these U910 input voltages correct the output voltage level by controlling the voltage at pin 6 (U910). The voltage level at pin 6 determines the switching repetition rate of the start multi, thus setting the time duration of current buildup in T970 primary, thereby setting the output voltage level in T970 secondary.

Any attempted change in supply output level is seen at U910, correcting the level at pin 6, changing the repetition rate of the start multi, correcting the supply output voltages.

In normal operation (normal DC input supply levels) Q888 is forward biased, holding Q887 cut off, having no effect on the start multi. If the DC input supply level drops too low, Q888 turns off, permitting Q887 to turn on, pulling Q887 collector toward ground, thereby disabling the start multi, shutting down the supply.

Since the secondary supplies and regulation are conventional circuitry, no detailed description is given.

Battery Charger (12)

With no instrument load on the battery, and FULL CHG-TRICKLE CHG switch in the FULL CHG position, the battery is charged at 150 mA as follows:

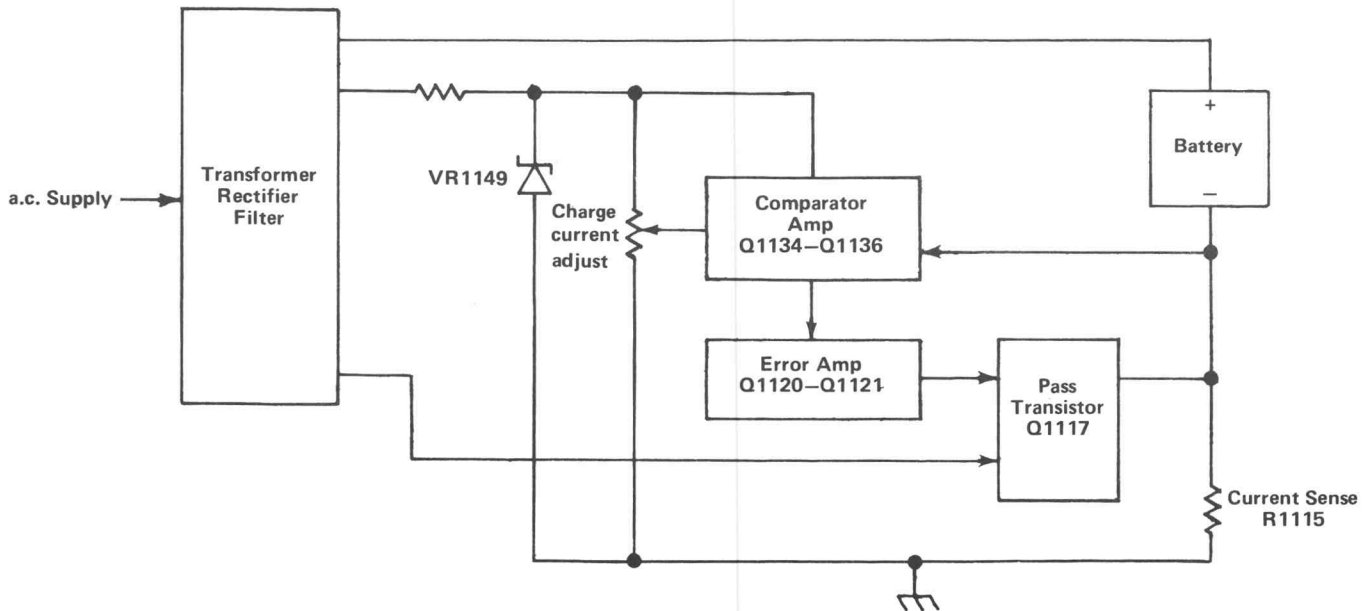

Battery Charger

Charge current is supplied by the 5-6 terminals of T1101 secondary, the diode bridge, D1110, through pass transistor, Q1117, and the sensing resistor, R1115.

The circuit which determines the charging current is a feedback amplifier consisting of a DC comparator (Q1134-Q1136), an error amplifier (Q1121-Q1120), and pass transistor (Q1117).

The base reference voltage of Q1136 is set by VR1149 and the divider, R1143 and variable R1144. Current for VR1149 is supplied by transformer secondary winding (7-8), rectifier CR1105, filter capacitor, C1105, and Zener current-setting resistor, R1105.

During full charge rate the voltage drop across sensing resistor, R1115 plus the drop across R1130 set the voltage level at Q1134. The base potential of Q1134 determines the current through R1139, setting the operating potential for Q1121. The current through the divider R1120-R1123 sets Q1120 base level. Q1120 conduction sets the base level for Q1117, the pass transistor, fixing the current to charge the battery at about 150 mA.

Any line voltage change is seen as a change in potential across the supply (transformer secondary terminals 5 and 6) and results in a change in potential across R1115 and is seen by Q1134 base as error signal.

The error signal is amplified in Q1121 and Q1120, which corrects the base drive to Q1117, bringing the feedback amplifier back to a state of balance.

If the instrument is turned on, the added load momentarily causes less charging current to flow to the battery. The reduced drop across R1115 is seen as error signal to the comparator Q1134-Q1136, causing a change in potential across R1139, which is amplified in Q1121-Q1120, increasing the drive to Q1117. The charge current increases to the point at which the feedback amplifier again reaches a balance (charge current back to 150 mA).

CR1137 and CR1138 prevent Q1134 and Q1136 collectors from rising to the point at which Q1134 and Q1136 would saturate during the periods when D110 (bridge) is not conducting.

The charge rate may be lowered to provide a trickle charge to the battery (to offset internal losses) by switching from FULL CHG to TRICKLE CHG. Switching R1133 into the circuit causes an additional drop across R1130, decreasing the voltage on Q1134 base. The reduced base voltage causes Q1117 drive (through Q1120-Q1121-R1139) to reduce the charge current to the battery.



MAINTENANCE

Introduction

This section of the manual contains maintenance information for use in preventive or corrective maintenance and troubleshooting the 326.

GENERAL

Cleaning

Avoid the use of chemical cleaning agents which might damage the plastics used in this instrument. Avoid chemicals which contain benzene, toluene, xylene, acetone or similar solvents.

Semiconductor Checks

Periodic checks of the semiconductors in the 326 are not recommended. The best check of semiconductor performance is actual operation in the instrument.

Recalibration

A calibration check is recommended after each 1000 hours of operation or every year if used infrequently. Replacement of components may necessitate recalibration of the affected circuits. Complete calibration instructions are given in the Performance Check/Adjust section.

Troubleshooting Aids

Diagrams. Circuit diagrams are given on foldout pages in the Diagrams section. The circuit number and electrical value of each component are given on the diagrams. Important voltages are also shown.

Circuit Boards. A tint band outlines each circuit board on the Schematic Diagrams and a photograph of each board is shown to the left of the diagram. Each board-mounted electrical component is identified in the photograph by its circuit number.

Voltages. Often the defective components can be located by checking for the correct voltage in the circuit. Some typical voltages are given on the Schematic Diagrams. These voltages are not absolute, and may vary slightly from instrument to instrument.

Power Supply Voltage. Table 4-1 lists the voltage tolerances of the power supplies in the 326. If the power

supply voltage is within the listed tolerance, the supply can be assumed to be operating properly. If outside the tolerance, the supply may be misadjusted or operating incorrectly.

TABLE 4-1

| Supply | Voltage | Ripple |
|---------|-----------|--------|
| -5 V | Within 2% | 10 mV |
| +5 V | Within 2% | 10 mV |
| +14 V | -20% | 200 mV |
| +100 V | -5% | 750 mV |
| +165 V | +8%, -6% | 750 mV |
| +1900 V | Within 2% | |

Troubleshooting Equipment

The following equipment is useful for troubleshooting the 326.

1. Semiconductor Tester. While the most convenient check of the semiconductor device is substitution or junction resistance measurement, some means of testing transistors and diodes may be helpful. For complete tests, the TEKTRONIX 576 Semiconductor Curve Tracer is recommended.

2. DC Voltmeter and Ohmmeter. For most applications a 20,000 ohms/volt VOM can be used to check voltages and resistance, if allowance is made for the circuit loading when making voltage measurements at high impedance points.

3. Test Oscilloscope. A test oscilloscope is required to check circuit waveforms. An oscilloscope having a DC to 10 MHz frequency response and 1 mV/Div to 10 V/Div vertical deflection factor is suggested. A 10X probe should be used where circuit loading is critical.

REPLACEMENT PARTS

Standard Parts

NOTE

All replacement parts should be direct replacements unless it is known that a different component will not adversely affect the instrument performance.

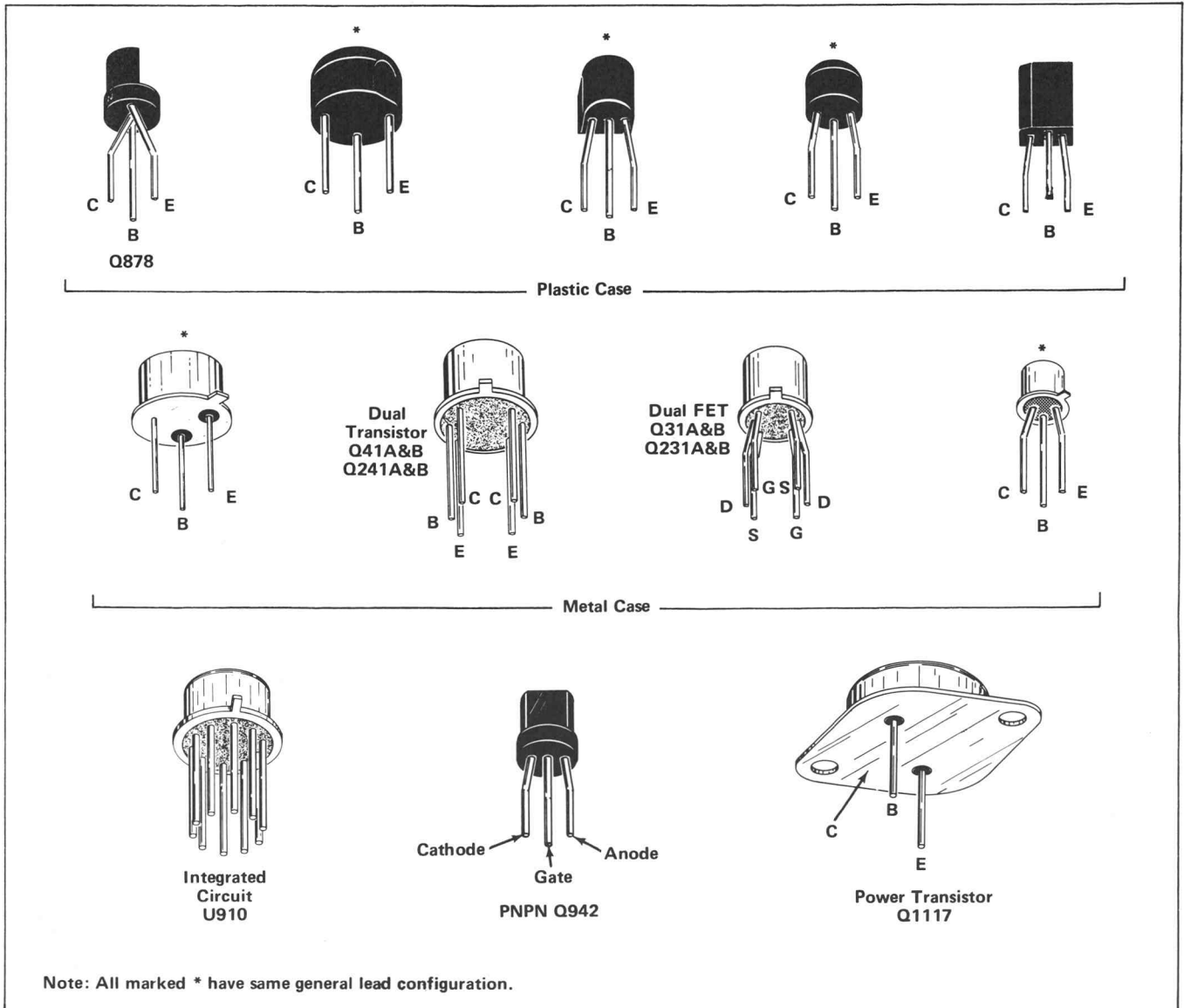

Fig. 4-1. Transistor lead configurations.

Refer to the Parts Ordering Information preceding the Electrical Parts List and Mechanical Parts List sections.

Special Parts

Some parts are manufactured or selected by SONY/TEKTRONIX to satisfy particular requirements, or are manufactured for SONY/TEKTRONIX to our specifications. These special parts are indicated in the parts lists by an asterisk preceding the part number. Most of the mechanical parts used in this instrument have been manufactured by SONY/TEKTRONIX. Order all special parts directly from your local TEKTRONIX Field Office or Representative.

ASSEMBLY AND COMPONENT REPLACEMENT

General

The exploded-view drawings associated with the Mechanical Parts List pullout page (Fig. 1, EXPLODED) may be helpful when disassembling or reassembling individual components or sub-assemblies.

Semiconductor Replacement

Replacement semiconductors should be of the original type or a direct replacement. Fig. 4-1 shows the lead

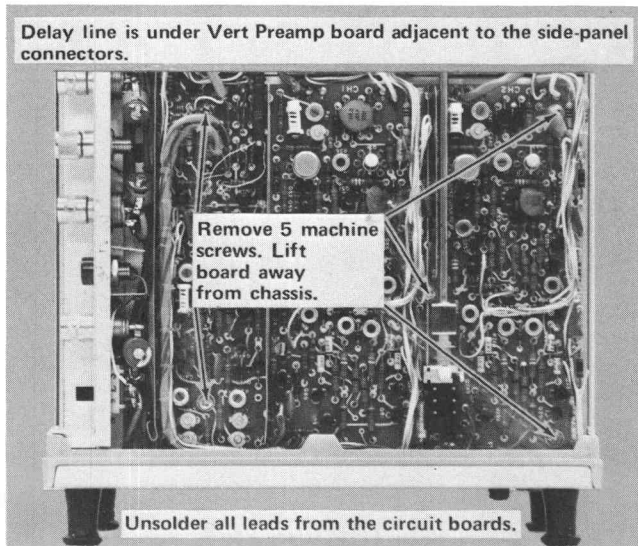

Fig. 4-2. Vertical Preamp circuit board removal.

configuration of the semiconductors used in this instrument. Some plastic cased transistors may have lead configurations which do not agree with those shown here. If a replacement transistor is made by a manufacturer other than the original, check the manufacturer's basing diagram for correct basing. All transistor sockets in this instrument are wired for the standard basing as used for metal-cased transistors.

Circuit Board Removal

Color codes for all wire connections to the boards can be found adjacent to the corresponding schematic (foldout at rear).

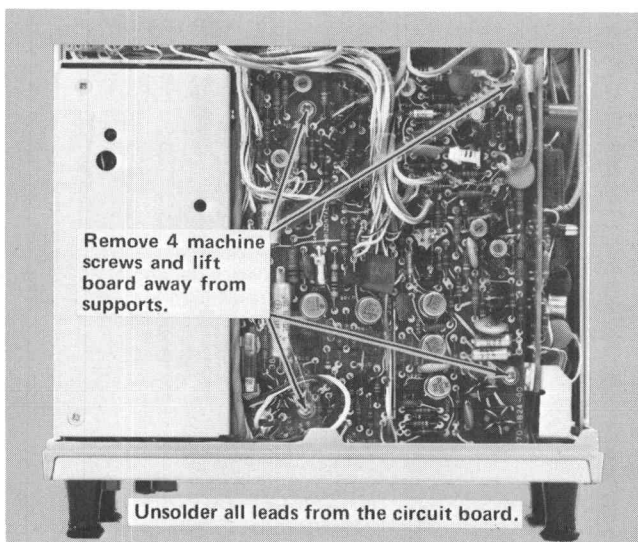

Fig. 4-3. Horizontal circuit board removal.

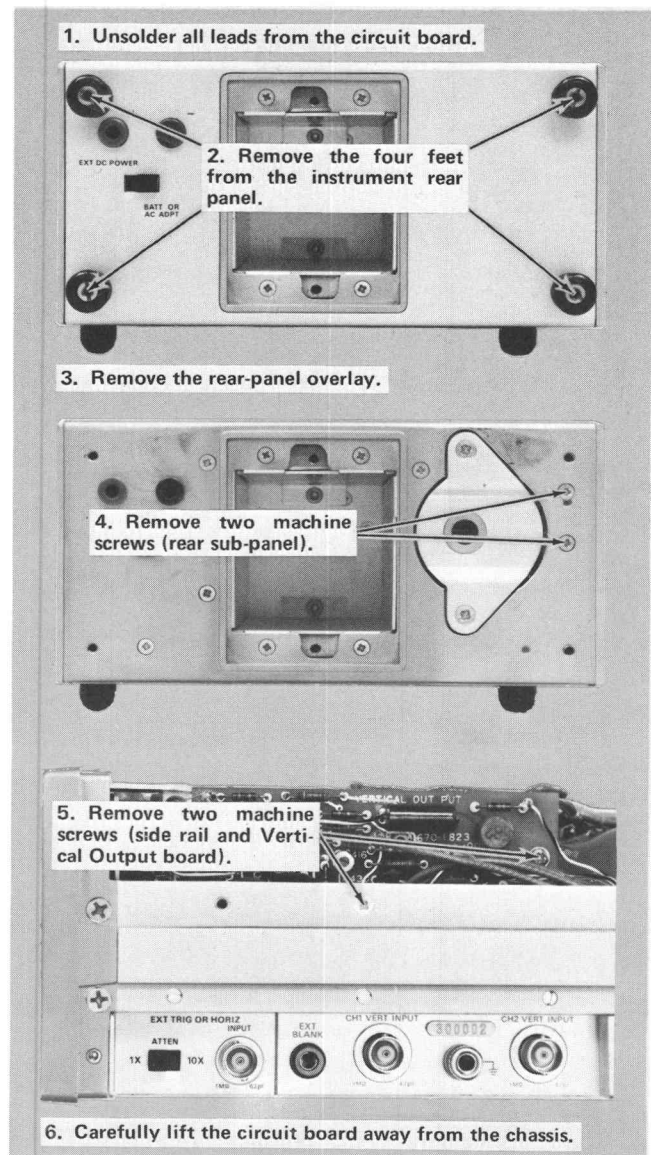

Fig. 4-4. Vertical Output circuit board removal.

Follow the instructions for the given circuit board in the following figures, 4-2 through 4-7.

Power Supply-Regulator Removal

CAUTION

Remove the battery pack before removing the Power Supply-Regulator board.

Remove the machine screws indicated by the arrows in Fig. 4-8A.

Very carefully pull the supply assembly straight up until the assembly is free of the chassis.

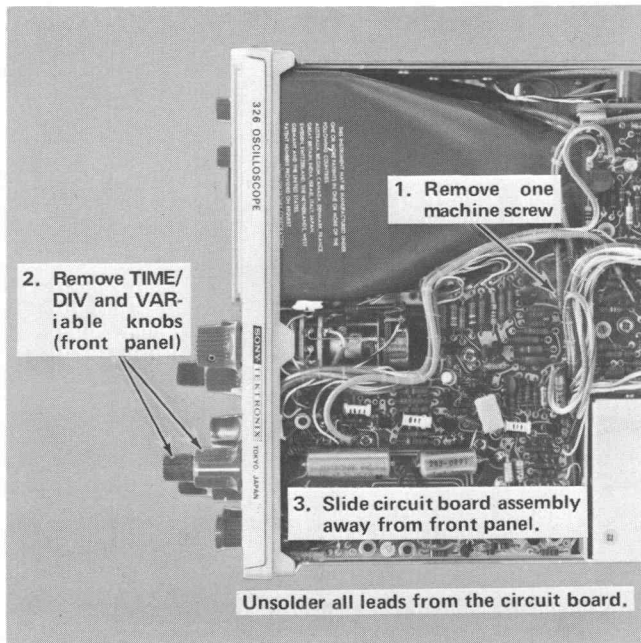

Fig. 4-5. Trigger Sweep circuit board removal.

Power Supply-Regulator Cover Removal

Remove the three machine screws indicated in Fig. 4-8B.

Remove the two machine screws on rear end of cover and remove the cover.

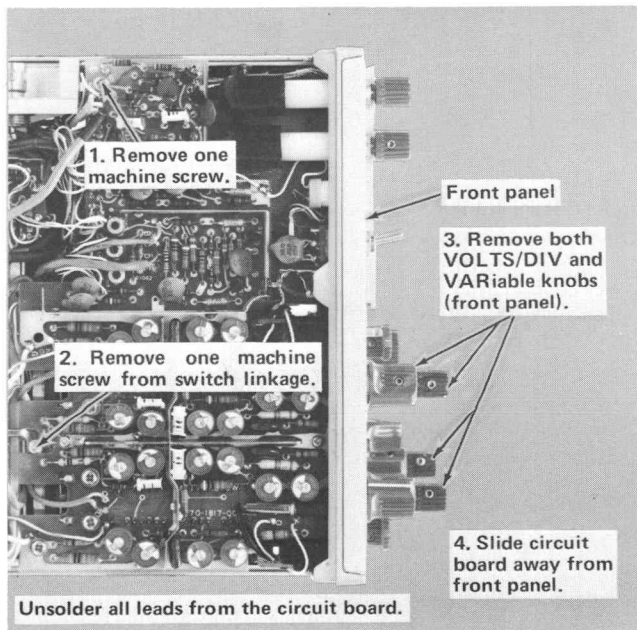

Fig. 4-6. Att/cal/sw circuit board removal.

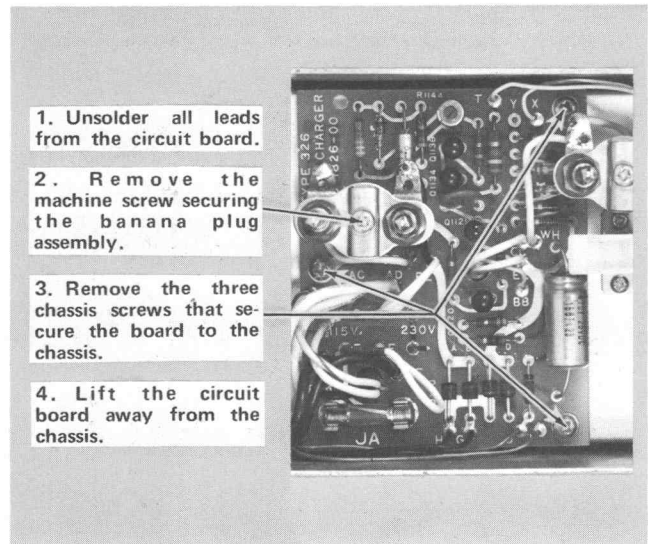

Fig. 4-7. Battery Charger circuit board removal.

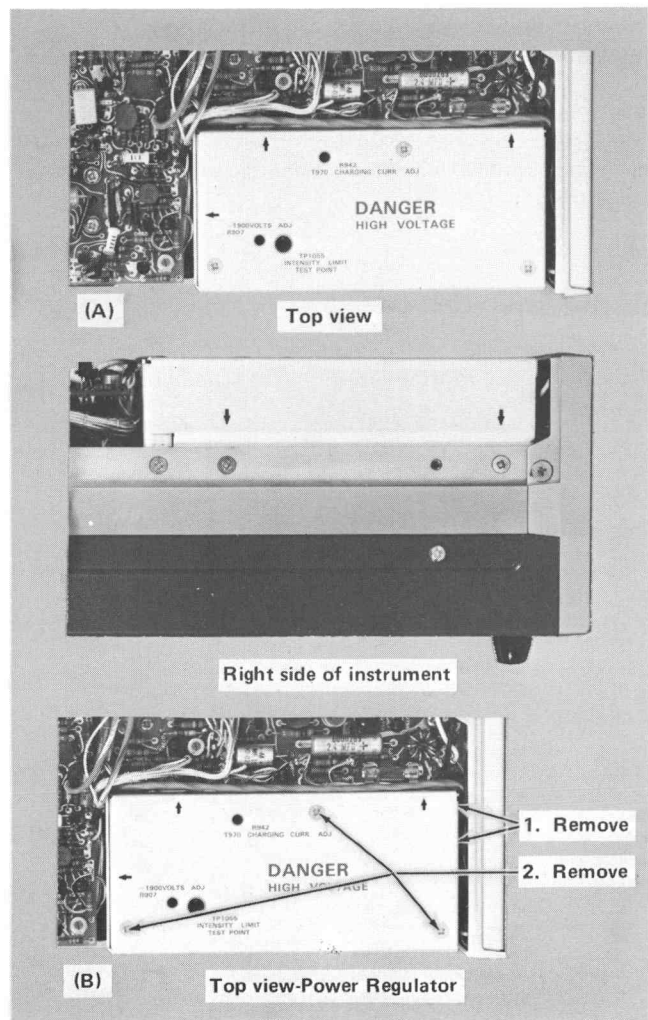

Fig. 4-8. Removing (A) Power Regulator and (B) Regulator cover.

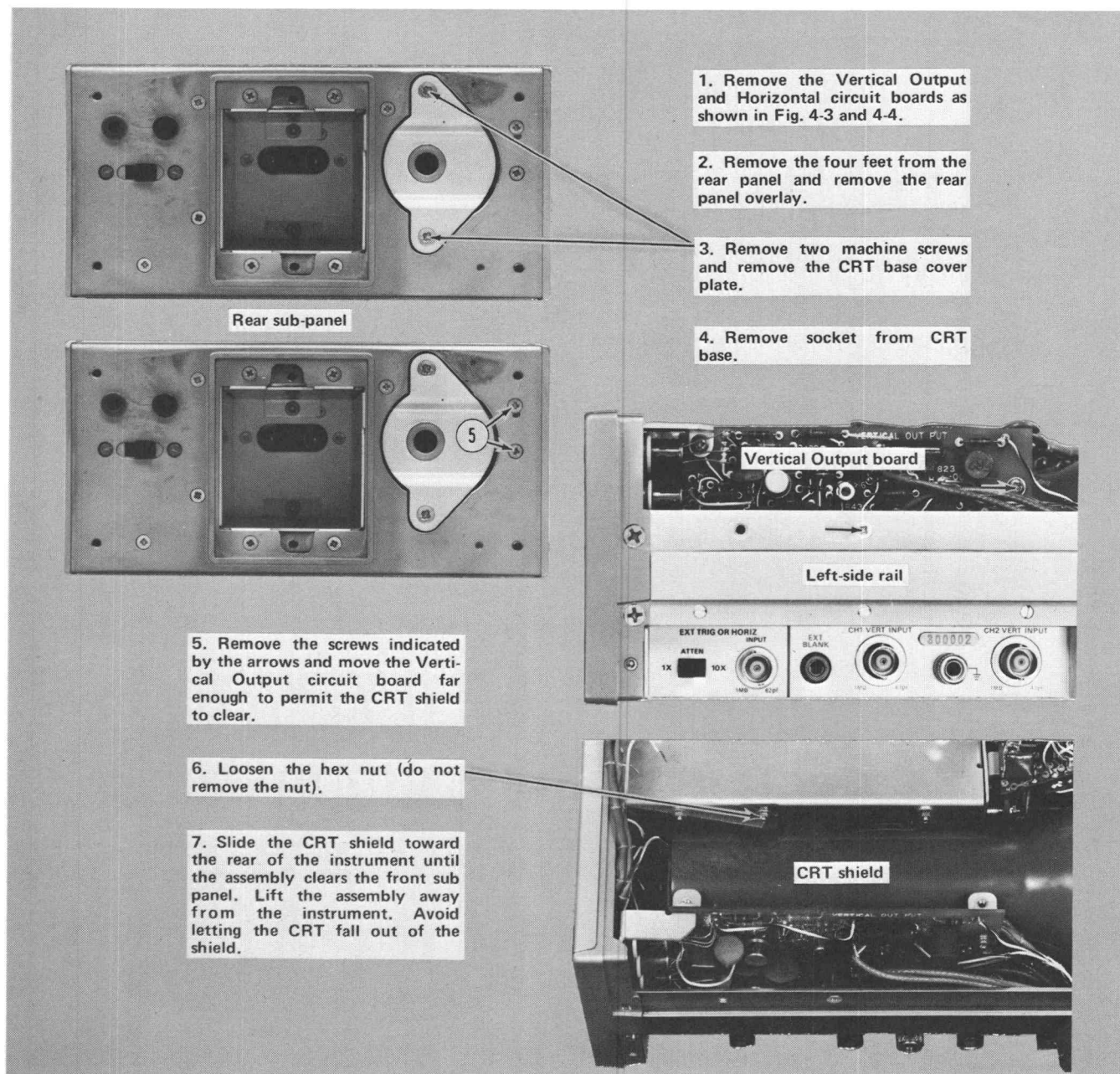

Fig. 4-9. CRT removal.

CRT Removal

Remove the CRT as shown in Fig. 4-9.

Cam Switch Replacement

Each new cam switch is shipped with a metal cover. This cover should be discarded after switch installation. Replace the switch as follows:

1. Remove the double cover from the pair of cam switches.

2. Remove the defective cam switch.

3. Leave the metal cover on the new cam switch and secure the switch to the circuit board in the same position as the switch just removed.

4. Check the new switch for proper mechanical operation (freedom of rotation, etc.).

5. Remove the metal cover from the switch just installed and replace the double cover over both switches.

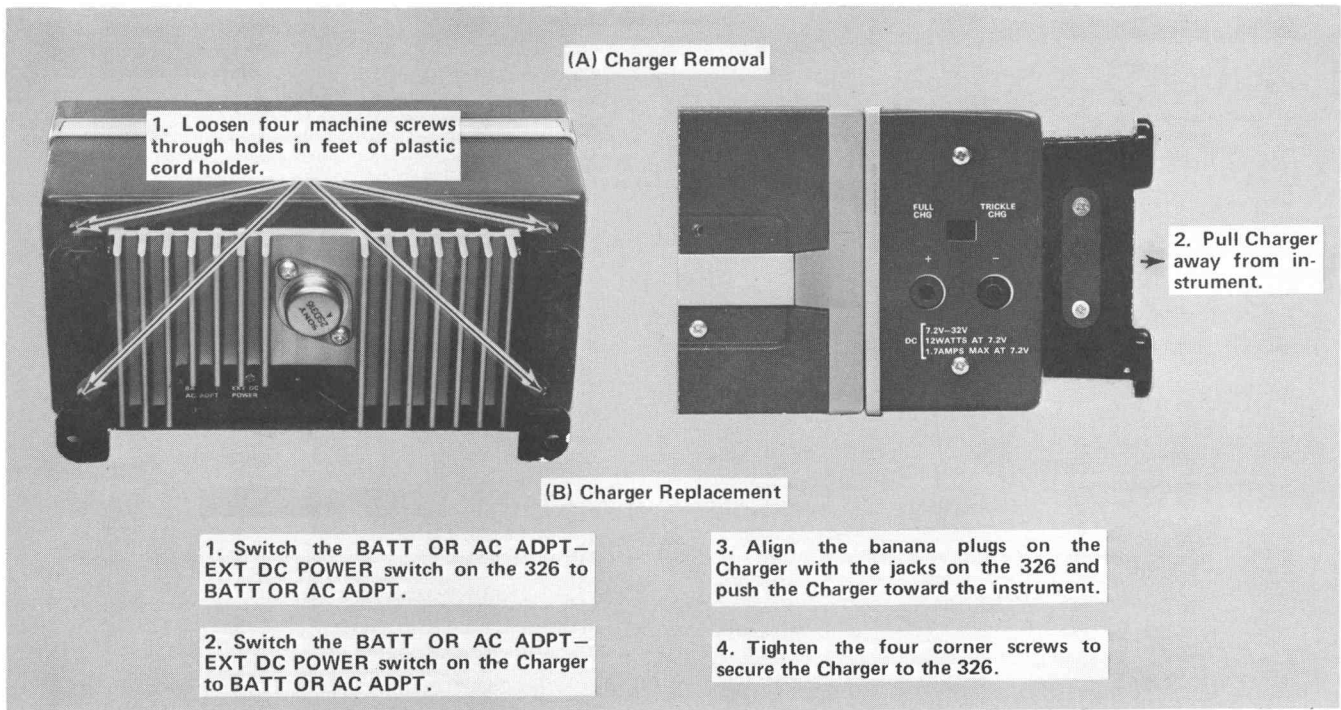

Fig. 4-10. Battery Charger (A) removal and (B) replacement.

Battery Charger Removal and Replacement

See Fig. 4-10 for Battery Charger removal and replacement instructions.

Instrument Repackaging

If the 326 is to be shipped over long distances by commercial transportation, it is recommended that the

instrument be repackaged in the original manner for maximum protection. Repackaging information and/or new shipping carton may be obtained from Tektronix, Inc. Contact the nearest TEKTRONIX Field Office or Representative. See Fig. 2 Repackaging (pullout, Mechanical Parts List, Section 8).

PERFORMANCE CHECK/ADJUSTMENT

Introduction

A performance check is recommended every 1000 hours of operation, or every year if used infrequently. Before complete calibration, the instrument should be cleaned and inspected as outlined in the Maintenance section.

The Performance Check can be used to check instrument performance without making any internal adjustments.

As an aid to checking the performance of the 326, a Short-Form Procedure is given preceding the complete procedure. To facilitate instrument checkout, the Short-Form Procedure lists the check and applicable tolerances. This procedure also includes the step, number, and title as listed in the complete Performance Check, and the page number on which each step begins. The Short-Form Procedure also provides spaces to record performance data or to check off steps as they are completed.

Following the Performance Check is a complete ADJUSTMENT procedure. Completion of the Adjustment Procedure insures that the instrument meets the electrical specifications given in Section 1.

NOTE

Limits, tolerances, and waveforms in the ADJUSTMENT procedure are given as calibration guides and should not be interpreted as instrument specifications except as specified in Section 1.

TEST EQUIPMENT REQUIRED

General

The following test equipment and accessories, or equivalent, are required for complete check or adjustment of the 326. Specifications given are the minimum necessary for accurate check or adjustment. Some of the recommended equipment may have specifications that exceed those given. All test equipment is assumed to be correctly calibrated and operating within the given specifications. If equipment is substituted, it must meet or exceed the specifications of the recommended equipment.

Special TEKTRONIX calibration fixtures are used to facilitate calibration and performance checks. These special fixtures are available from Tektronix, Inc. Order by part number through your local TEKTRONIX Field Office or representative.

Test Equipment

1. Precision DC voltmeter. Accuracy, within $\pm 0.1\%$; range, zero to 200 volts. For example, Fluke Model 825A Differential DC Voltmeter.

2. DC voltmeter (VOM). Minimum sensitivity, 20,000 ohms/volt; accuracy, checked to within 1% at -1900 volts. For example, Triplet Model 630-NA.

3. Variable DC power supply. Voltage range, at least $+7$ to $+32$ volts; current capability, at least 1.0 ampere; output voltage, measured within 3%.

4. Test oscilloscope. Bandwidth, DC to 10 MHz; minimum deflection factor, 2 mV/Div; accuracy, within 3%. SONY/TEKTRONIX Type 324 Oscilloscope is recommended.

5. Time-mark Generator. Marker output, 0.1 μ s to 0.1 s; marker accuracy, within 0.1%. TEKTRONIX 2901 Time-Mark Generator is recommended.

6. Standard Amplitude Calibrator. Amplitude accuracy, within 0.25%; signal amplitude, 5 mV to 100 volts; output signal, square wave. TEKTRONIX Calibration Fixture 067-0502-01 is recommended.

7. Square-Wave Generator. Must have the following output capabilities (may be obtained from separate generators): 120 volts amplitude at 1 kHz repetition rate with a one microsecond risetime; 500 mV into 50 ohms at 1.0 kHz and 1.0 MHz repetition rates with a 50 ns risetime. TEKTRONIX Type 106 Square-Wave Generator is recommended (meets both output requirements).

8. High-Frequency Constant-Amplitude Sine-Wave Generator. Frequency, 350 kHz to above 10 MHz; reference frequency, 50 kHz; output amplitude, variable from 5 mV to 0.5 volt into 50 ohms; amplitude accuracy, constant

Performance Check/Adjustment—326

within 3% at 50 kHz and from 350 kHz to above 10 MHz. TEKTRONIX Type 191 Constant Amplitude Signal Generator is recommended.

9. Low-Frequency Constant-Amplitude Sine-Wave Generator. Frequency, 2 Hz to 100 kHz; output amplitude, variable from 50 mV to 16 volts, peak to peak; amplitude accuracy, constant within 3% from 2.0 Hz to 100 kHz. For example, General Radio 1310-A Oscillator (use a General Radio Type 274QBJ adapter to provide BNC output).

10. Variable Autotransformer¹. Must be capable of supplying a range of 90 to 136 volts (180 to 272 volts for 230-volts nominal line). If autotransformer does not have an AC voltmeter, monitor the output with an AC voltmeter having a range of 136 or 272 volts, RMS. For example, General Radio W10MT3A Metered Variac Autotransformer for 115 volts or General Radio W20MT3A for 230-volt nominal operation.

11. 1X Probe with BNC connector. TEKTRONIX P6011 is recommended.

12. Cable. Impedance, 50 ohms; type, RG-58/U; length, 42 inches; connectors, BNC. TEKTRONIX Part Number 012-0057-01.

13. Calibration Shield. SONY/TEKTRONIX Calibration Fixture. TEKTRONIX Part Number 067-0669-00.

14. Adapter. Adapts GR874 to BNC male connector. TEKTRONIX Part Number 017-0063-00.

15. Termination. Impedance, 50 Ω ; accuracy, $\pm 2\%$; connectors, BNC. TEKTRONIX Part Number 011-0049-01.

16. 10X Attenuator. Impedance, 50 Ω ; accuracy, $\pm 2\%$; connectors, BNC. TEKTRONIX Part Number 011-0059-01.

17. Input RC Normalizer. Time constant, 1 M Ω and 47 pF; attenuation, 2X; connectors, BNC. TEKTRONIX Calibration Fixture 067-0541-00.

18. 10X probe for the 326 and the 324 Test Oscilloscope. TEKTRONIX P6049A Probe is recommended (two supplied as accessories).

19. Current Probe for the 324 Test Oscilloscope. TEKTRONIX P6021 is recommended. TEKTRONIX Part Number is 015-0140-02.

20. Adapter, BNC to Binding Post. TEKTRONIX Part Number 103-0033-00.

21. BNC T Connector. TEKTRONIX Part Number 103-0030-00.

22. Patch Cord. Length, 18 inches; connectors, banana plug-jack and BNC male. TEKTRONIX Part Number 012-0090-00.

23. Patch Cord. Length, 18 inches; connectors, banana plug-jack to banana plug-jack. TEKTRONIX Part Number 012-0039-00.

24. Cable. Impedance, 50 Ω type RG-58/U; length, 18 inches; connectors, BNC. TEKTRONIX Part Number 012-0076-00.

25. Dual Input Coupler. Matched signal transfer to each input. TEKTRONIX Calibration Fixture 067-0525-00.

Adjustment Tool

26. Low-capacitance screwdriver. 1 1/2-inch shaft. TEKTRONIX Part Number 003-0000-00.

SHORT-FORM PERFORMANCE CHECK AND INDEX

326 Serial Number

Date

By

1. Check Astigmatism

Sharp, well-defined trace.

2. Check Trace Alignment

Marker baseline should be parallel to the horizontal graticule lines.

3. Check Geometry

Deviation from a straight line, not more than 0.1 division.

¹ Not required for performance check only.

4. Check Compression
Compression not to exceed 0.15 division.
5. Check CH 1 X1 Vertical Gain
Vertical deflection, 5 divisions, ± 0.15 division.
6. Check CH 1 X10 Vertical Gain
Vertical deflection, 5 divisions, ± 0.15 division.
7. Check CH 1 Vertical Deflection Accuracy
Indicated deflection, $\pm 3\%$.
8. Check CH 1 Variable Volts/Div Range
Range at least 2.5:1.
9. Check High Frequency Compensation
Check for best square corner (leading edge). Aberrations not to exceed +2% or -2% with peak-to-peak not to exceed 3%.
10. Check CH 1 Input Capacitance
0.2 div, or less, overshoot or rounding (47 pF, ± 4 pF).
11. Check CH 1 Volts/Div Switch Compensation
Optimum square corner and flat top at each Volts/Div switch setting.
12. Check CH 1 Vertical Upper -3 dB Point (X1 Gain)
At least 10 MHz.
13. Check CH 1 Vertical Upper -3 dB Point (X10 Gain)
At least 5 MHz.
14. Check CH 1 Vertical AC-Coupled Lower-3 dB Point
10 Hz or less.
Repeat steps 4 through 14 for CH 2.
15. Check Common-Mode Rejection
Rejection Ratio, 20:1.
16. Check Magnified Registration
Middle marker within 1.0 division of the center vertical graticule line.
17. Check Normal Timing
Check Timing as shown in Table 5-2.
18. Check Variable Time/Div Range
Range, at least 2.5:1.
19. Check Magnified Timing
Check timing as shown in Table 5-3.
20. Check External Horizontal
Horizontal deflection, 4 div to 6.7 div.
Variable range, 10:1 or greater.
21. Check External Horizontal Bandwidth (Upper -3 dB Point)
At least 200 kHz.
22. Check External Blanking
Check for blanking of a portion of each cycle.
23. Check High Frequency Triggering
Stable Triggering on:
0.3 div display at 1.0 MHz, INT LF REJ,
1.0 div display at 10.0 MHz, INT LF REJ,
1.5 div display at 1.0 MHz, EXT AC and DC.
24. Check Low-Frequency Triggering
Stable Triggering on:
1.5 div display at 30 Hz in EXT AC and DC,
0.3 div display at 30 Hz in INT AC.

Performance Check/Adjustment—326

25. Check Low-Frequency Reject

Stable display cannot be obtained at 30 Hz.

26. Check Calibrator

Duty Cycle, 40% to 60%.

Output amplitude, 5 divisions.

PERFORMANCE CHECK PROCEDURE

General

The following procedure uses the equipment listed under Test Equipment Required. If other equipment is substituted, control settings or checking setup may need to be altered to meet the requirements of the equipment used. Operating instructions for the test equipment are not given in this procedure. Refer to the test equipment instruction manual if more information is required.

The control settings throughout the procedure continue from the preceding step unless otherwise noted.

NOTE

Control titles that are printed on the front panel of the 326 are capitalized in this procedure (e.g., CH 1 VOLTS/DIV). Associated equipment controls are initial capitalized only (e.g., Output Amplitude).

PERFORMANCE CHECK

Initial Control Settings for Performance Check

| | |
|----------------------|----------|
| CH 1 and CH 2 | |
| VOLTS/DIV | .5 V |
| Input Coupling AC-DC | DC |
| Mode | CH 1 |
| TRIGGERING | |
| CH 1—NORM | CH 1 |
| Coupling | INT AC |
| TIME/DIV | 1 ms |
| Horiz POSITION | Midrange |

1. Check Astigmatism

a. Connect the Time-Mark Generator output to the CH 1 VERT INPUT with a BNC cable. Set the Time-Mark Generator for 1 ms markers.

b. Set the INTENSITY control midway between a barely visible trace and fully clockwise.

c. Set the trigger controls for a stable display.

d. CHECK—Markers should be well defined within the areas indicated in Fig. 5-1 with optimum setting of the FOCUS control.

2. Check Trace Alignment

a. Vertically position the marker baseline to the center horizontal graticule line.

b. CHECK—Marker baseline should be parallel to the center horizontal graticule line.

3. Check Geometry

a. Set VOLTS/DIV switch to .1.

b. Vertically position the marker baseline below the bottom graticule line.

c. CHECK—CRT display for minimum curvature of the vertical markers. Maximum deviation from a straight line, 0.1 division.

d. Disconnect the Time-Mark Generator.

e. Set LEVEL/SLOPE to +AUTO.

f. Vertically position the trace to the top graticule line.

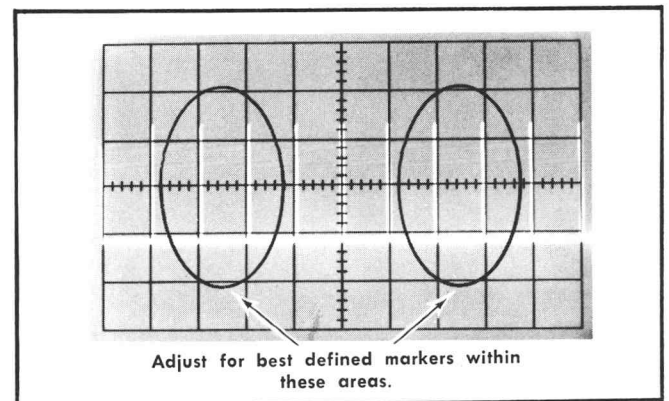

Fig. 5-1. Astigmatism check, typical display.

g. CHECK—Deviation from a straight line should not exceed 0.1 division.

h. Vertically position the trace to the bottom graticule line.

i. CHECK—Deviation from a straight line should not exceed 0.1 division.

4. Check Compression

a. Set CH 1 VOLTS/DIV to 5 DIV CAL.

b. Vertically position the bottom of the display to the first graticule line below the horizontal center line.

c. Reduce the display to exactly two divisions with the Variable VOLTS/DIV control.

d. Vertically position the top of the display to the top graticule line.

e. CHECK—Compression (reduction in amplitude) not to exceed 0.15 division.

f. Vertically position the bottom of the display to the bottom graticule line.

g. CHECK—Compression, not to exceed 0.15 division.

5. Check CH 1 X1 Vertical Gain

Reset the following controls:

VOLTS/DIV 0.1
Variable VOLTS/DIV CAL

a. Connect the Standard Amplitude Calibrator output connector to CH 1 VERT INPUT connector via a 50-ohm BNC cable.

b. Set the Standard Amplitude Calibrator for a 50 mV square-wave output.

c. Vertically center the display.

d. CHECK—Vertical deflection equal to 5 divisions, ±0.15 division.

6. Check CH 1 X10 Vertical Gain

a. Set the Standard Amplitude Calibrator for a 5 mV square-wave output.

b. Pull the POSITION X10 VERT GAIN control.

c. Vertically center the display.

d. CHECK—Vertical deflection equal to 5 divisions, ±0.15 division.

7. Check CH 1 Vertical Deflection Accuracy

a. Push the POSITION X10 VERT GAIN control knob.

b. CHECK—Using the VOLTS/DIV switch and Standard Amplitude Calibrator settings given in Table 5-1, check deflection accuracy at each position of the VOLTS/DIV switch.

TABLE 5-1

| VOLTS/DIV Switch Settings | Calibrator Amplitude | Vertical Deflection in divisions | Max Error in divisions |
|---------------------------|----------------------|----------------------------------|------------------------|
| .01 | 50 mV | 5 | ±0.15 |
| .02 | 0.1 V | 5 | ±0.15 |
| .05 | 0.2 V | 4 | ±0.12 |
| .1 | 0.5 V | 5 | ±0.15 |
| .2 | 1 V | 5 | ±0.15 |
| .5 | 2 V | 4 | ±0.12 |
| 1 | 5 V | 5 | ±0.15 |
| 2 | 10 V | 5 | ±0.15 |
| 5 | 20 V | 4 | ±0.12 |
| 10 | 50 V | 5 | ±0.15 |

8. Check CH 1 Variable Volts/Div Range

a. Set the Standard Amplitude Calibrator for a 50 mV square-wave output.

b. Reset CH 1 VOLTS/DIV to .01.

c. Vertically center the display.

Performance Check/Adjustment—326

d. CHECK—Rotate the CH 1 Variable VOLTS/DIV control fully counterclockwise. Display must reduce to two divisions or less.

e. Return the VOLTS/DIV Variable to the CAL position.

9. Check High Frequency Compensation

Reset the controls as follows:

| | |
|---------------|-----------|
| X10 VERT GAIN | Pulled |
| X10 HORIZ MAG | Pulled |
| TIME/DIV | 1 μ s |

a. Connect the Square-Wave Generator Fast-Rise + Output connector to CH 1 VERT INPUT connector through a GR to BNC adapter, 50-ohm BNC cable, 10X, 50-ohm attenuator, and a 50-ohm BNC termination in the order given.

b. Set the Square-Wave Generator for a four division display at 100 kHz.

c. Horizontally position the leading edge of the square wave into the viewing area. Reset triggering as necessary for correct display. See Fig. 5-2.

d. CHECK—The display for best square corner (aberrations not to exceed +2% or -2% with peak-to-peak aberrations not to exceed 4%.

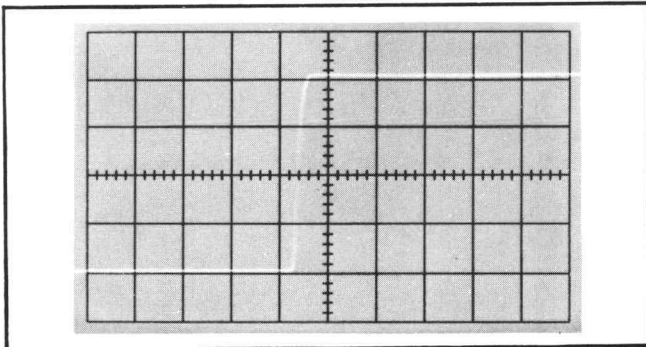

Fig. 5-2. High frequency response check, typical display.

10. Check CH 1 Input Capacitance

Reset the controls as follows:

| | |
|--------------------|--------|
| TIME/DIV | .5 ms |
| CH 1 X10 VERT GAIN | Pushed |

a. Connect the Square-Wave Generator High Amplitude Output connector to the CH 1 VERT INPUT connector through the GR to BNC adapter, 50-ohm BNC cable, 50-ohm termination, and 47 pF RC Normalizer in the order given.

b. Set the Square-Wave Generator for a five-division display at one kHz.

c. CHECK—CRT display for 0.2 division, or less, of overshoot or rounding (47 pF, ± 4 pF; see Fig. 5-3).

11. Check CH 1 Volts/Div Switch Compensation

a. Connect a P6049A Probe to the CH 1 VERT INPUT connector.

b. From the Square-Wave Generator High Amplitude Output connect a GR to BNC adapter, 10X 50-ohm BNC attenuator and BNC binding post adapter.

c. Connect the P6049A Probe tip to the BNC-binding post adapter.

d. Set the Square-Wave Generator for a five-division display at 1 kHz.

e. Compensate the probe as described in the probe manual.

f. CHECK—CRT display for optimum square corner and flat top at each VOLTS/DIV switch setting. Adjust the generator output for each switch position to maintain a five-division display.

12. Check CH 1 Vertical -3 dB Point (X1 Gain)

Reset the controls as follows:

| | |
|----------------|-----------|
| CH 1 VOLTS/DIV | .01 |
| X10 VERT GAIN | Pushed in |
| TIME/DIV | 1 ms |

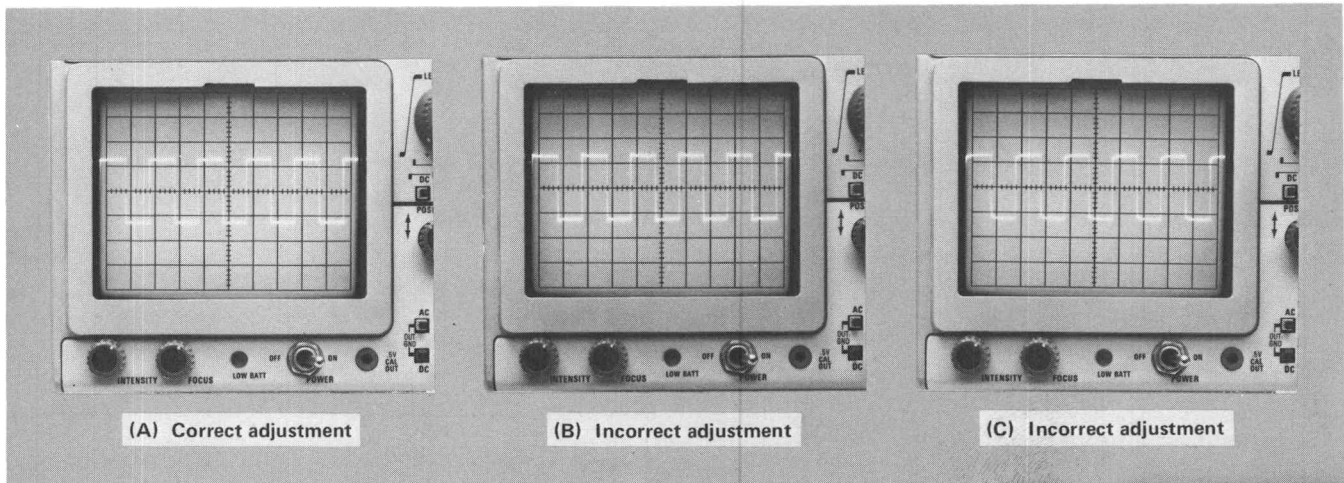

Fig. 5-3. Input capacitance check, typical displays.

a. Connect a High-Frequency Constant-Amplitude Sine-Wave Generator to the CH 1 VERT INPUT connector through the GR to BNC adapter, 50-ohm BNC cable, 10X 50-ohm BNC attenuator and a 50-ohm BNC termination.

b. Set the Constant-Amplitude Sine-Wave Generator for a four-division display, centered on the graticule, at the generator reference frequency (50 kHz).

c. Without changing the generator output amplitude, increase the frequency until the display amplitude is reduced to 2.8 divisions (-3 dB point).

d. CHECK—Generator output frequency must be at least 10 MHz.

13. Check CH 1 X10 Vertical Gain Upper -3 dB Point

a. Pull the X10 VERT GAIN switch.

b. Set the Constant-Amplitude Sine-Wave Generator for a four-division display, centered on the graticule, at the generator reference frequency (50 kHz).

c. Without changing the generator amplitude, increase the frequency until the display amplitude is reduced to 2.8 divisions (-3 dB point).

d. CHECK—Generator output frequency must be 5 MHz or greater.

14. Check CH 1 Vertical AC-Coupled Lower -3 dB Point

Reset the controls as follows:

| | |
|---------------|-----------|
| CH 1 AC-DC | AC |
| X10 VERT GAIN | Pushed in |
| TIME/DIV | 2 ms |

a. Connect the Low-Frequency Constant-Amplitude Sine-Wave Generator to the CH 1 VERT INPUT connector through the 50-ohm BNC cable and a 50-ohm termination.

b. Set the generator for a four-division display, centered on the graticule, at a 1.0 kHz reference frequency.

c. Without changing the generator amplitude, decrease the frequency until the display amplitude decreases to 2.8 divisions.

d. CHECK—Generator frequency must be 10 Hz or less.

e. Remove the low-frequency generator, set the Mode switch to CH 2, and check CH 2, starting with step 4. After completing steps 4 through 14, for CH 2, continue with step 15.

15. Check Common-Mode Rejection

Change the following control settings:

| | |
|-------------|--------|
| TRIGGERING | |
| CH 1—NORM | CH 1 |
| LEVEL/SLOPE | +AUTO |
| Coupling | INT AC |

Performance Check/Adjustment—326

TIME/DIV 1 μ s
 Mode CH 1
 CH 1 VOLTS/DIV 0.01

a. Connect the Low-Frequency Constant-Amplitude Sine-Wave Generator output through a 50-ohm BNC cable, 50-ohm BNC termination, and a 50-ohm dual-input coupler to CH 1 and CH 2 VERT INPUT connectors.

b. Adjust the generator output amplitude for an eight-division display (80 mV) at 2 MHz.

c. Set Mode switch to ADD.

d. Set the CH 2 INVERT button to the OUT position.

e. CHECK—Display for not more than 0.4 division of display (20:1 rejection ratio).

16. Check Magnified Registration

Reset controls as follows:

CH 1 VOLTS/DIV .1
 Input AC-DC DC
 TIME/DIV 1 ms

a. Connect the Time-Mark Generator to the CH 1 VERT INPUT through the 50-ohm BNC cable and 50-ohm termination.

b. Set the Time-Mark Generator for 5 ms markers.

c. Set the trigger controls for a stable display in the variable positive-slope area.

d. Position the middle marker (of the three markers displayed) to the center vertical line.

e. Pull the X10 HORIZ MAG switch. Do not change knob rotational position.

f. CHECK—Middle marker should remain within one division of the center vertical graticule line.

17. Check Normal Timing

a. Push the X10 HORIZ MAG knob.

b. Set the Time-Mark Generator for 1-ms markers and the 326 TIME/DIV to 1 ms.

c. Set the trigger control for a stable display in the variable positive slope area.

d. CHECK—CRT display for one marker per division. With the second marker positioned exactly to the second vertical line, the tenth marker must be within 3% (0.24 div) of the tenth vertical line (see Fig. 5-4).

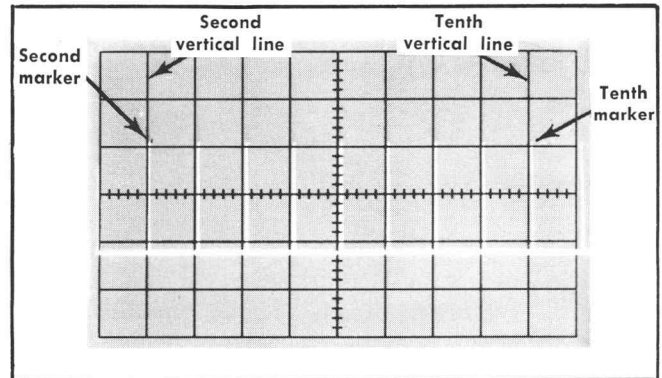

Fig. 5-4. Timing check.

NOTE

Unless otherwise noted, use the middle eight horizontal divisions (between the second and tenth vertical graticule lines) when checking timing.

e. CHECK—Timing through the remaining positions of the TIME/DIV switch as shown in Table 5-2.

TABLE 5-2

| TIME/DIV Setting | Time Marks | Accuracy Center 8 Div | Accuracy Any 2 Div |
|------------------|------------|-----------------------|--------------------|
| 1 s | 1 s | 4% | 5% |
| .5 s | .5 s | | |
| .2 s | .1 s | | |
| .1 s | .1 s | | |
| 50 ms | 50 ms | | |
| 20 ms | 10 ms | | |
| 10 ms | 10 ms | | |

TABLE 5-2 (cont)

| TIME/DIV Setting | Time Marks | Accuracy Center 8 Div | Accuracy Any 2 Div |
|------------------|------------|-----------------------|--------------------|
| 5 ms | 5 ms | 3% | 4% |
| 2 ms | 1 ms | | |
| 1 ms | 1 ms | | |
| .5 ms | .5 ms | | |
| .2 ms | .1 ms | | |
| .1 ms | .1 ms | | |
| 50 μ s | 50 μ s | | |
| 20 μ s | 10 μ s | | |
| 10 μ s | 10 μ s | | |
| 5 μ s | 5 μ s | | |
| 2 μ s | 1 μ s | | |
| 1 μ s | 1 μ s | | |

18. Check Variable Time/Div Range

a. Set Time-Mark Generator to 10 ms marker and the 326 TIME/DIV to 1 ms.

b. Set trigger controls for a stable display in the variable positive-slope area.

c. Align the markers with the first and last graticule lines.

d. Turn the Variable TIME/DIV control fully counter-clockwise.

e. CHECK—Display for four-division maximum spacing between markers.

19. Check Magnified Timing

Reset the controls as follows:

| | |
|---------------------|----------|
| Horizontal POSITION | Midrange |
| X10 HORIZ MAG | Pulled |
| Time-Mark Generator | .1 ms |

a. Set TRIGGERING controls in the variable-slope area for a stable display.

b. CHECK—CRT display for one marker per division between the second and tenth vertical lines. With a marker positioned exactly to the second vertical line, a marker must coincide, within 4%, with the tenth vertical line.

c. CHECK—Each VOLTS/DIV switch position as shown in Table 5-3.

TABLE 5-3

| TIME/DIV Setting | Time-Mark Gen Output | Display Markers/Div | Max Error for Given Accuracy |
|------------------|----------------------|---------------------|------------------------------|
| 1 μ s | .1 μ s | 1 | 5% (0.4 div) |
| 2 μ s | .1 μ s | 2 | |
| 5 μ s | .1 μ s | 5 | 4% (0.32 div) |
| 10 μ s | 1 μ s | 1 | |
| 20 μ s | 1 μ s | 2 | |
| 50 μ s | 1 μ s | 5 | |
| .1 ms | 10 μ s | 1 | |
| .2 ms | 10 μ s | 2 | |
| .5 ms | 10 μ s | 5 | |
| 1 ms | .1 ms | 1 | |
| 2 ms | .1 ms | 2 | |
| 5 ms | .1 ms | 5 | |
| 10 ms | 1 ms | 1 | |
| 20 ms | 1 ms | 2 | |
| 50 ms | 1 ms | 5 | |
| .1 s | 10 ms | 1 | 5% (0.4 div) |
| .2 s | 10 ms | 2 | |
| .5 s | 10 ms | 5 | |
| 1 s | 100 ms | 1 | |

20. Check External Horizontal

a. Set TRIG OR HORIZ ATTEN switch (side panel) to 10X.

b. Set TIME/DIV to EXT HORIZ and TRIGGERING to EXT AC.

c. Connect the Standard-Amplitude Calibrator to the EXT TRIG OR HORIZ INPUT connector with a 50-ohm BNC cable.

Performance Check/Adjustment—326

d. Set the Standard-Amplitude Calibrator for a 10-volt square-wave output.

e. CHECK—CRT display for a horizontal deflection of 4.0 div to 6.7 div between dots (1.5 volts/div to 2.5 volts/div).

f. Set the calibrator to 1 volt and switch the EXT TRIG OR HORIZ ATTEN to X1.

g. CHECK—CRT display for a horizontal deflection of 4 div to 6.7 div between dots (150 mV to 250 mV/div).

h. Rotate the EXT HORIZ VARIABLE control fully counterclockwise.

i. CHECK—CRT display for at least one tenth the deflection measured in the preceding step (indicates 10:1, or greater, range).

21. Check External Horizontal Bandwidth (Upper -3 dB Point)

a. Set the EXT HORIZ Variable control to CAL (clockwise).

b. Connect the low-frequency Constant-Amplitude Sine-Wave Generator to the EXT TRIG OR HORIZ INPUT connector through a 50-ohm BNC cable and a 50-ohm BNC termination.

c. Set the generator output for five divisions of horizontal deflection at 1 kHz.

d. Without changing the output amplitude, increase the output frequency of the generator to 200 kHz.

e. CHECK—CRT display for at least 3.5 divisions of horizontal display.

f. Disconnect all test equipment.

22. Check External Blanking

Set the controls as follows:

| | |
|----------------|-----------|
| CH 1 VOLTS/DIV | .2 |
| TRIGGERING | INT AC |
| TIME/DIV | 5 μ s |

a. Connect the low-frequency Sine-Wave Generator to the CH 1 VERT INPUT connector, through a BNC cable and BNC T connector.

b. Set the generator for a five-division vertical display (5-volt positive peaks) at 100 kHz.

c. Connect the output of the BNC T connector to the EXT BLANK connector with a BNC to banana patch cord.

d. CHECK—CRT display for blanking of a portion of each cycle (see Fig. 5-5). The INTENSITY control may require resetting to show the blanking.

23. Check High Frequency Triggering

Reset the controls as follows:

| | |
|----------------|-------------|
| VOLTS/DIV CH 1 | .1 |
| TRIGGERING | CH 1, +AUTO |
| TIME/DIV | 1 μ s |

a. Connect the high-frequency Constant-Amplitude Sine-Wave Generator to the CH 1 VERT INPUT connector through the GR to BNC adapter, 50-ohm BNC cable, 50-ohm BNC termination, and BNC T connector. Connect the output of the BNC T connector to the EXT TRIG OR HORIZ INPUT connector with a 50-ohm BNC cable.

b. Set the generator for a 0.3 division display at 1.0 MHz.

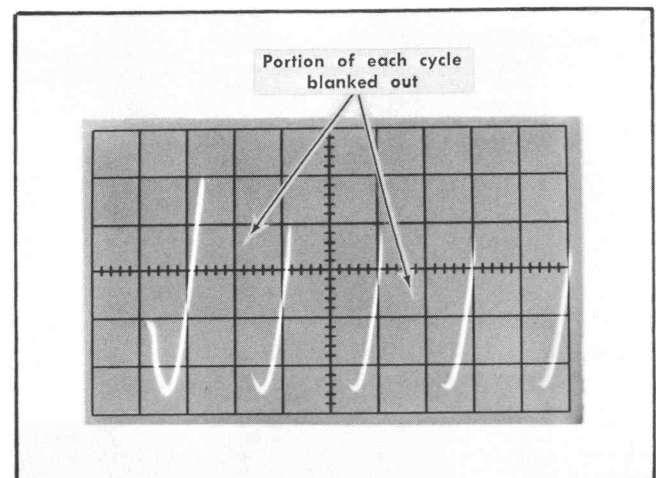

Fig. 5-5. External blanking check, typical display.

c. CHECK—Stable display is presented with the TRIGGERING controls set to INT AC and LF REJ, in the variable positive-slope area, in the variable-slope negative area, and in both +AUTO and –AUTO.

d. Set the generator for a one-division display at 10 MHz.

e. Pull the X10 HORIZ MAG knob.

f. CHECK—Stable display is presented with the TRIGGERING controls set to INT AC and LF REJ in the variable positive-slope area, in the variable negative-slope area, and in both +AUTO and –AUTO.

g. Reset the controls as follows:

| | |
|---------------|-----------|
| TRIGGERING | EXT, AC |
| X10 HORIZ MAG | Pushed in |

h. Set the generator for a 1.5-division display at 1.0 MHz.

i. CHECK—Stable display is presented in AC and DC in variable positive-slope area, variable negative-slope area, and in both +AUTO and –AUTO.

j. Reset the generator for a five-division display at 10 MHz.

k. Pull the X10 HORIZ MAG knob.

l. CHECK—Stable display is presented in AC and DC in the variable positive-slope area, variable negative-slope area, and in both +AUTO and –AUTO.

m. Move the signal to CH 2, switch CH 1–NORM to NORM, Mode to CH 2, and repeat steps a through l.

n. Disconnect the high-frequency generator.

24. Check Low-Frequency Triggering

Set the 326 controls as follows:

| | |
|---------------|-------------|
| TIME/DIV | 20 ms |
| X10 HORIZ MAG | Pushed in |
| TRIGGERING | +AUTO, CH 1 |

a. Connect the low-frequency Constant-Amplitude Sine-Wave Generator to the CH 1 VERT INPUT connector through the 50-ohm BNC cable, 50-ohm termination, and the 50-ohm BNC T connector. Connect the output of the BNC T connector to the EXT TRIG OR HORIZ INPUT connector with a 50-ohm BNC cable.

b. Set the low-frequency generator for a 1.5-division display (150 mV) at 30 Hz.

c. CHECK—Stable display is presented in EXT AC and DC, in the variable positive-slope, variable negative-slope area, and +AUTO and –AUTO.

d. Set the generator for a 0.3 division display at 30 Hz.

e. Set the TRIGGERING to INT AC.

f. CHECK—Stable display is presented in the variable negative-slope area, the variable positive-slope area, the +AUTO, and –AUTO positions.

25. Check Low-Frequency Reject

a. Change the low-frequency Sine-Wave Generator for a 0.3 division display at 15 kHz.

b. CHECK—Stable triggering can be obtained in + and –AUTO, and in variable positive- and negative-slope areas.

c. Without changing the generator output amplitude, set the frequency to 30 Hz.

d. Reset TIME/DIV to 10 ms.

e. CHECK—Stable display cannot be obtained at any setting of the TRIGGERING LEVEL/SLOPE controls.

26. Check Calibrator

Change the following control settings:

| | |
|----------------|------------------------|
| CH 1 VOLTS/DIV | 5 DIV CAL |
| Input AC-DC | GND (both buttons out) |
| TRIGGERING | |
| LEVEL/SLOPE | –AUTO |
| Coupling | INT AC |
| TIME/DIV | .1 ms |

Performance Check/Adjustment—326

a. Set the Variable TIME/DIV control for one complete cycle in ten divisions.

b. CHECK—The display for length of the positive segment of the square wave between four and six divisions (duty cycle 40% to 60%).

c. Change the following control settings:

| | |
|--------------------|-------|
| VOLTS/DIV | .1 |
| Input AC-DC | DC |
| TIME/DIV | .5 ms |
| Variable VOLTS/DIV | CAL |

d. Connect a 1X probe to the CH 1 INPUT connector.

e. Connect the probe tip to the CAL OUT jack.

f. CHECK—Display for five divisions of vertical amplitude.

SHORT-FORM ADJUSTMENT PROCEDURE AND INDEX

326 Serial Number _____

Calibration Date _____

Calibrated By _____

1. Adjust T970 Primary Current

ADJUST R942 for 3.6 A in T970 primary.

2. Adjust High Voltage Supply and Check Regulation

ADJUST R907 for -1900 volts, within 2%.

3. Adjust Intensity Limit

ADJUST R1064 for 315 μ A CRT cathode current.

4. Adjust +5-Volt Power Supply

ADJUST R1004 for 0.500 volt between CAL OUT jack and chassis ground.

5. Adjust -5-Volt Power Supply

ADJUST R1030 for -5.0 volts, \pm 75 mV at -5-volt test point.

6. Check Low-Voltage Power Supply Ripple and Regulation

CHECK the low-voltage supplies while varying the external DC supply voltage between +9.0 and +32 volts.

7. Adjust Variable Volts/Div Balance (each channel)

ADJUST R37 and R237 for no trace shift as Variable VOLTS/DIV is rotated.

8. Adjust CH 1 Vertical X10 Balance

ADJUST R36 for minimum trace shift as the X10 VERT GAIN switch is pulled out and pushed in.

9. Adjust CH 2 Vertical X10 Balance

ADJUST R236 for minimum trace shift as the X10 VERT GAIN switch is pulled out and pushed in.

10. Adjust Deflection Plate DC Level (each channel)

ADJUST R82 to center the measured range at +50 volts.

ADJUST R84 to center the measured range at +50 volts.

ADJUST R69 for a meter reading of +50 volts.

ADJUST R282 to center the measured range at +50 volts.

ADJUST R284 to center the measured range at +50 volts.

ADJUST R269 for a meter reading of +50 volts.

11. Adjust Astigmatism

ADJUST R1068 (with FOCUS) for the best marker definition.

12. Adjust Trace Alignment

ADJUST R1060 to align marker baseline with graticule horizontal centerline.

13. Adjust CRT Geometry
ADJUST R1062 for minimum curvature of markers and baseline.
14. Adjust Limit Centering (each channel)
ADJUST R69 for minimum compression.
ADJUST R269 for minimum compression.
15. Adjust CH 1 X1 Vertical Gain
ADJUST R65 for 5.00 divisions of display.
16. Adjust CH 1 X10 Vertical Gain
ADJUST R41 for 5.00 divisions of display.
17. Adjust CH 2 Vertical X1 Gain
ADJUST R265 for 5.00 divisions of display.
18. Adjust CH 2 Vertical X10 Gain
ADJUST R241 for 5.00 divisions of display.
19. Adjust High Frequency Compensation
ADJUST R411 for the best flat top on the square wave.
ADJUST R421 for the best flat bottom on the square wave.
ADJUST R418, R428, C417, C427, C418, C428, and R430 for best front corner.
20. Adjust Input Capacitance
ADJUST C21 for minimum overshoot or rounding.
ADJUST C221 for minimum overshoot or rounding.
21. Adjust Volts/Div Switch Compensation
ADJUST each attenuator as shown in Table 5-5.
22. Adjust Magnified Registration
ADJUST R713 for position coincidence in X1 and X10.

23. Adjust Normal Timing
ADJUST R611 midway between triggered display and auto sweep.
ADJUST R702 for one marker per division.
24. Adjust Sweep Length and Centering
ADJUST R618 for 10.7 division sweep length.
ADJUST R704 to set trace start.
25. Adjust Magnified Timing
ADJUST R717 for one marker per division.
26. Adjust High Speed Timing
ADJUST C620F for 1 marker per division.
ADJUST C701 for best sweep start linearity.
ADJUST C782 for best sweep and linearity.
27. Adjust External Horizontal 10X Compensation
ADJUST C538 for minimum rounding or overshoot.
28. Adjust Battery Charger Charge Rate
ADJUST R1144 for 45 mV across R1115.

ADJUSTMENT PROCEDURE

Initial Control Settings:

| | |
|----------------------|-----------|
| INTENSITY | midrange |
| FOCUS | midrange |
| POWER | OFF |
| CH 1 and CH 2 | |
| VOLTS/DIV | 5 DIV CAL |
| POSITION | midrange |
| X10 VERT GAIN | pushed in |
| Input Coupling AC-DC | AC |
| Mode | CH 1 |
| CH 2 INVERT | pushed in |
| TIME/DIV | .5 ms |
| TRIGGERING | |
| CH 1—NORM | CH 1 |
| LEV/SLOPE | +AUTO |
| INT—EXT | INT AC |
| Horizontal POSITION | midrange |

Preliminary Procedure for Complete Calibration

1. Remove the Battery Charger from the 326.
2. Remove the cabinet from the 326.
3. Remove the Battery Pack.
4. Remove the Power Regulator following the removal instructions in the Maintenance Section (4).
5. Connect an external DC supply to the 326 EXT DC POWER input jacks (note polarity).
6. Set the external DC supply output to +9 volts.
7. Switch the 326 POWER switch to ON.

1. Adjust T970 Primary Current (R942)

- a. Connect the current probe around the red-on-white lead from terminal 'M' on the Power Regulator Control Board (see Fig. 5-6A for location).
- b. Set the current probe Passive Termination for 2 mA/mV and the Test Oscilloscope vertical deflection to .5 V/Div.
- c. Observe a waveform on the test oscilloscope similar to that shown in Fig. 5-6B.
- d. ADJUST—R942 for 3.6 divisions (3.6 amp) of vertical display.
- e. Remove the current probe.

2. Adjust High Voltage Supply and Check Regulation

- a. Connect a DC voltmeter + lead to terminal 'O' or 'P' (see Fig. 5-7A) on H.V. board and — lead to chassis ground.

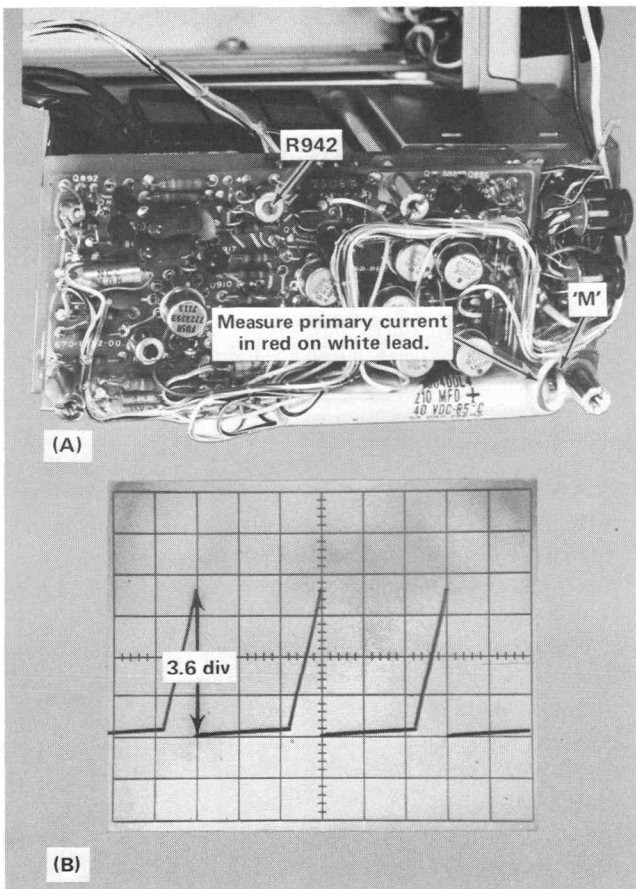

Fig. 5-6. T970 primary current adjust. (A) Location of terminal M. (B) Typical waveform.

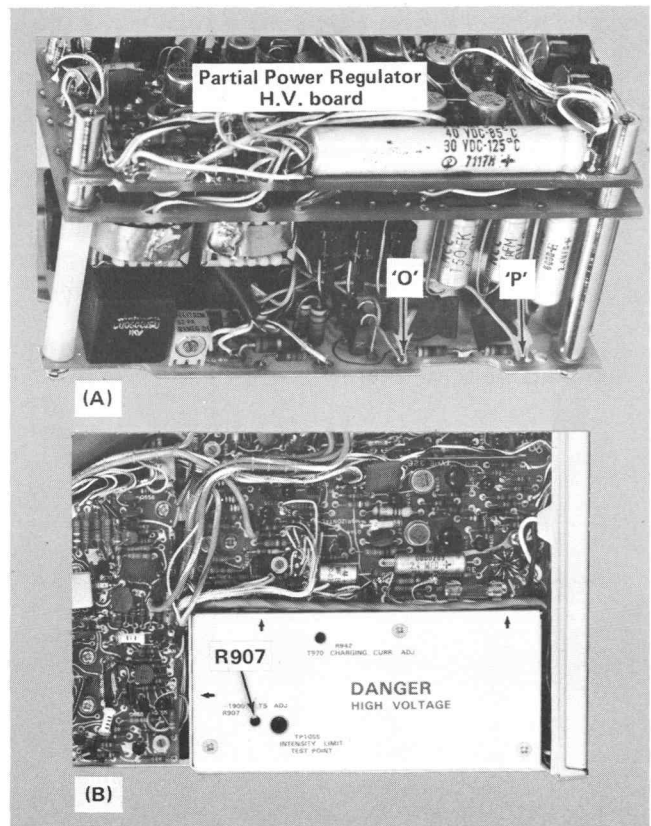

Fig. 5-7. High Voltage adjustment. Location of (A) Terminals O and P, and (B) Location of R907.

b. ADJUST—R907 (see Fig. 5-7B) for a meter reading of -1900 volts.

c. Change the variable DC power source output voltage between $+9$ and $+32$ volts. Set the INTENSITY control fully clockwise at $+9$ volts and fully counterclockwise at $+32$ volts.

d. CHECK—for less than ± 40 volts change in the -1900 -volt level (-1860 volts to -1940 volts).

NOTE

If the high-voltage supply is out of regulation, check the regulation of the low-voltage supplies (steps 4 and 5) before troubleshooting the high-voltage supply.

e. Return the variable DC power source to $+9$ volts.

f. INTERACTION—Adjusting the -1900 -volt supply will affect the display. Therefore, a complete calibration must follow.

3. Adjust Intensity Limit (R1064)

NOTE

This step need not be performed except where display brightness is low or when replacing the CRT.

a. Unsolder the junction of R1056-R1057 (see Fig. 5-8) and lift the ends of the resistors clear of the circuit board. Connect the two resistor leads together and connect to the positive lead of the VOM set to read $600 \mu\text{A}$, full scale. Connect the negative lead to the point on the circuit board to which the resistors were originally connected.

b. Set the 326 INTENSITY control fully clockwise.

c. ADJUST—R1064 (see Fig. 5-8 for location) for a meter reading of $315 \mu\text{A}$.

d. Remove the meter and reconnect the resistors to the circuit board.

4. Adjust +5-Volt Power Supply (R1004)

a. Connect a precision DC voltmeter between the front-panel CAL OUT jack and chassis ground.

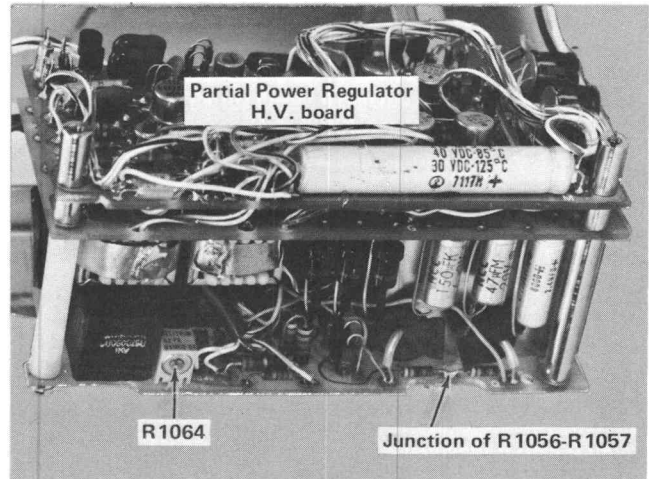

Fig. 5-8. Intensity Limit adjustment. Location of cathode current measurement point and R1064.

b. Remove Q9 from its socket on the ATT/CAL/SW circuit board (see Fig. 5-9A).

c. ADJUST—R1004 (see Fig. 5-9B for location) for a meter reading of 0.500 volt.

d. Disconnect the precision DC voltmeter and replace Q9.

e. Connect the precision DC voltmeter between terminal 'BZ' on the Horizontal board (see Fig. 5-10A for location) and chassis ground.

f. CHECK—for a meter reading of $+5.0$ volts, ± 75 mV.

g. INTERACTION—may affect operation of all circuits within the instrument.

5. Adjust -5 -Volt Power Supply (R1030)

a. Connect the precision DC voltmeter between terminal 'BB' on the Horizontal board (see Fig. 5-10A for location) and chassis ground.

b. ADJUST—R1030 (see Fig. 5-10A for location) for a meter reading of -5 volts, ± 25 mV.

c. INTERACTION—may affect operation of all circuits within the instrument.

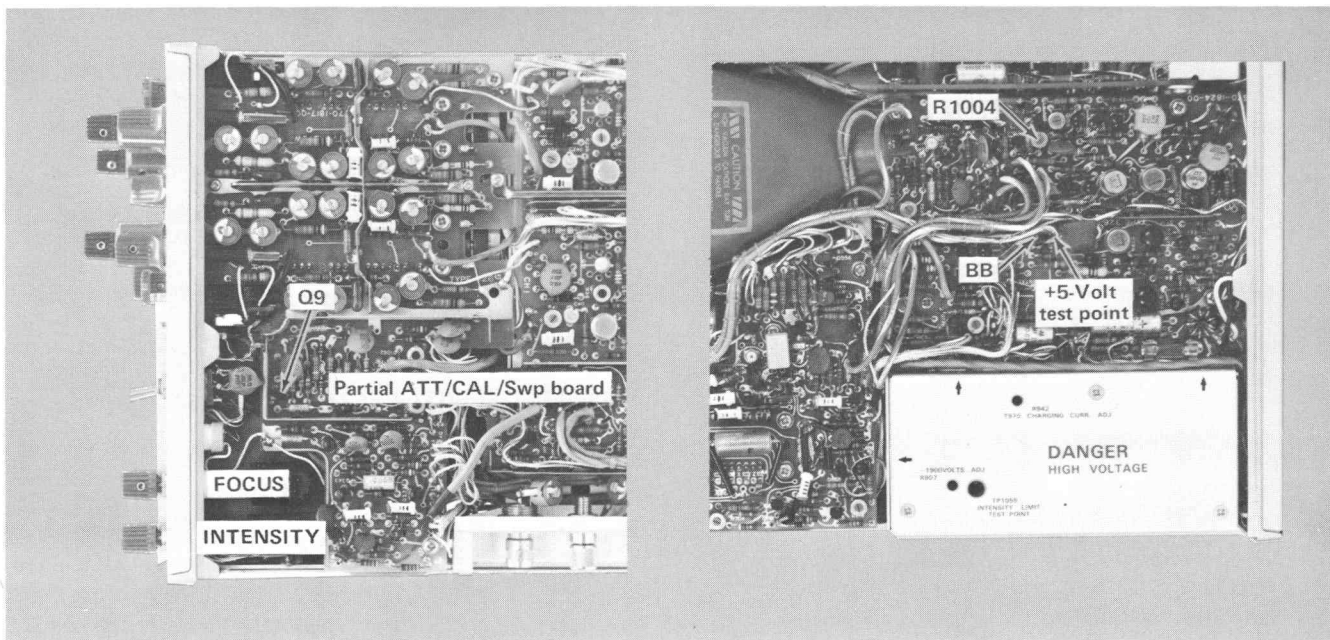

Fig. 5-9. +5-Volt supply adjustment. Location of (A) Q9, and (B) R1004 and +5-Volt test point.

6. Check Low-Voltage Power-Supply Ripple and Regulation

a. Set the following 326 front-panel controls:

TIME/DIV EXT HORIZ
 Vertical POSITION Position spot off screen

b. Connect a 1X probe to the Test Oscilloscope vertical input.

c. Set the Test Oscilloscope vertical deflection factor to 0.01 Volts/Div, AC Coupled, and sweep rate at 20 μ s/Div.

d. CHECK—the Test Oscilloscope display for ripple of each supply while varying the external DC voltage supply between +9 volts and +32 volts. Table 5-4 lists the supply voltage limits, ripple limits, and location of test point for each supply. See Fig. 5-10B.

e. Disconnect the external DC supply and replace the Power Regulator in the 326. Reconnect the external DC supply or replace the internal battery pack.

TABLE 5-4

| Supply | Voltage Limits | Maximum Ripple | Location of Test Point |
|--------|----------------|----------------|------------------------|
| -5 V | Within 2% | 10 mV | 'BB' on Horiz Board |
| +5 V | Within 2% | 10 mV | 'BZ' on Horiz Board |
| +14 V | -20% | 200 mV | 'BD' on Horiz Board |
| +100 V | -5% | 750 mV | 'L' on Rect Board |
| +165 V | +8%, -6% | 750 mV | 'K' on Rect Board |

7. Adjust Variable Volts/Div Balance (R37-R237)

a. Set the 326 Mode switch to CH 1.

b. Vertically position the trace to the center graticule line.

c. Rotate the CH 1 Var VOLTS/DIV control through-out its range noting the vertical trace shift.

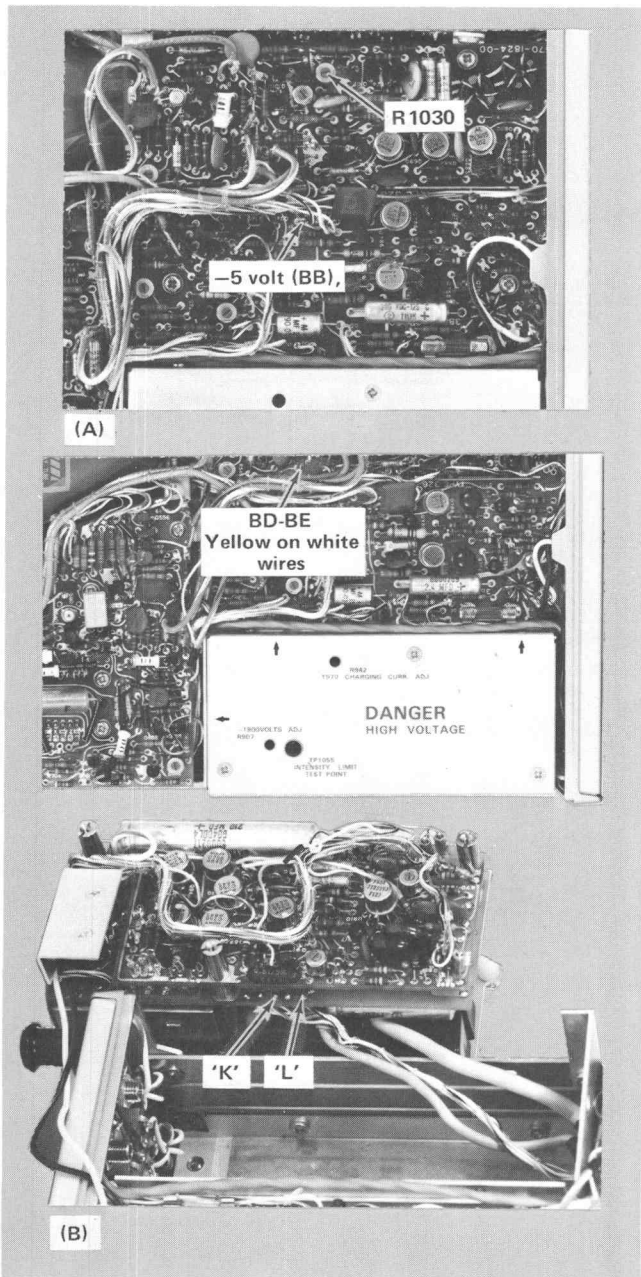

Fig. 5-10. -5-Volt adjustment. Location of (A) -5-Volt Test Point and R1030, and (B) unregulated supply test points.

d. ADJUST-R37 (see Fig. 5-11B) for no trace shift as the Variable VOLTS/DIV control is rotated. If necessary, use the Vertical POSITION control to keep the trace on screen during this adjustment. Set Mode to CH 2.

e. Rotate CH 2 Var VOLTS/DIV throughout its range.

f. ADJUST-R237 (see Fig. 5-11B) for no trace shift as the CH 2 Var VOLTS/DIV control is turned.

g. Return both CH 1 and CH 2 Var VOLTS/DIV controls to the CAL position.

h. Set Mode switch to CH 1.

8. Adjust CH 1 Vertical X10 Balance (R36)

a. Vertically position the CH 1 trace to the center horizontal line.

b. Pull the CH 1 X10 VERT GAIN switch and check trace shift as the knob is pulled.

c. ADJUST-R36 (see Fig. 5-11B) for minimum trace shift as the X10 VERT GAIN switch is pulled out and pushed in. To prevent changing the knob position (rotational) the X10 VERT GAIN switch can be actuated using the control bracket behind the front panel.

d. Push the CH 1 X10 VERT GAIN switch in and switch Mode to CH 2.

9. Adjust CH 2 Vertical X10 Balance (R236)

a. Vertically position the CH 2 trace to the center horizontal graticule line.

b. Pull the CH 2 X10 VERT GAIN switch and check trace shift as the knob is pulled out.

c. ADJUST-R236 (see Fig. 5-11B) for minimum trace shift as the X10 VERT GAIN switch is pulled out and pushed in. To prevent changing the knob position (rotational) the X10 VERT GAIN switch can be actuated using the control bracket behind the front panel.

d. Push the CH 2 X10 VERT GAIN switch in. Switch Mode to CH 1.

10. Adjust Deflection Plate DC Level (R82-R84-R69)

a. Connect a DC voltmeter between Q457 collector (case) on the Vertical Output board (see Fig. 5-11A) and chassis ground.

b. Turn the CH 1 Vertical POSITION control fully clockwise and note the meter reading. Rotate the Vertical POSITION control fully counterclockwise and again note the meter reading.

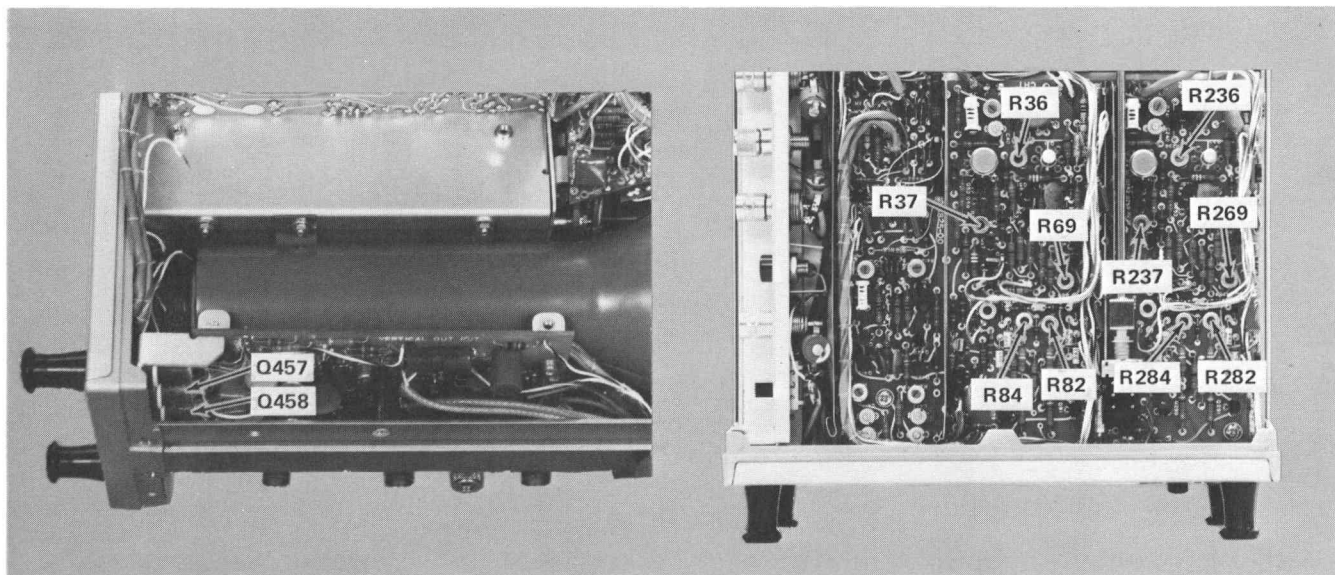

Fig. 5-11. Deflection Plate DC Level adjustment. Location of controls.

c. ADJUST—R82, Upper Defl Plate DC Level control (see Fig. 5-11B) to center the measured range at +50 volts.

d. Connect the DC voltmeter between Q458 collector (case) on the Vertical Output board (see Fig. 5-11A) and chassis ground.

e. Turn the CH 1 Vertical POSITION control fully clockwise and note the meter reading. Rotate the Vertical POSITION control fully counterclockwise and again note the meter reading.

f. ADJUST—R84, Lower Defl Plate DC Level control (see Fig. 5-11B) to center the measured range at +50 volts.

g. Vertically position the CH 1 trace to graticule centerline.

h. Connect the DC voltmeter between Q457 collector and chassis ground.

i. ADJUST—R69 for a meter reading of +50 volts.

j. Perform steps a through i, for CH 2, using controls R282, R284, and R269.

11. Adjust Astigmatism (R1068)

Reset the following 326 controls:

| | |
|----------------|------|
| Mode | CH 1 |
| CH 1 VOLTS/DIV | .5 |
| CH 1 AC-GND-DC | DC |
| TIME/DIV | 1 ms |

a. Set the INTENSITY control midway between a barely visible trace and fully clockwise.

b. Connect a Time-Mark Generator (set to 1 ms markers) to the CH 1 VERT INPUT connector (use BNC cable). Trigger as necessary for stable display.

c. ADJUST—FOCUS (front panel) and Astig (R1068) controls (see Fig. 5-12A) for the best definition of the markers within the areas indicated in Fig. 5-12B.

12. Adjust Trace Alignment (R1060)

a. Vertically position the marker display baseline to the graticule horizontal centerline.

b. ADJUST—R1060, Trace Rotation control (see Fig. 5-12A) to align the marker display baseline parallel to the graticule horizontal centerline.

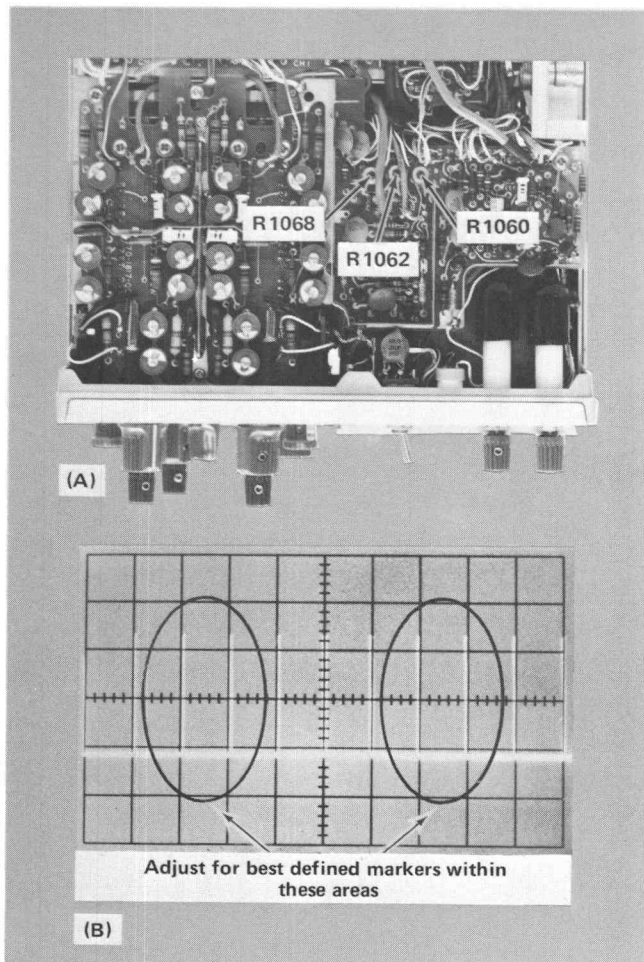

Fig. 5-12. (A) Location of Astigmatism, Trace Alignment, and Geometry controls and (B) Typical display.

13. Adjust CRT Geometry (R1062)

Set CH 1 VOLTS/DIV switch to .1.

- a. Vertically position the marker display baseline below the bottom of the graticule.
- b. Adjust the INTENSITY control as necessary for normal viewing brightness.
- c. ADJUST—R1062, Geometry control (see Fig. 5-12A) for minimum curvature of the vertical markers.
- d. Disconnect the Time-Mark Generator from the instrument.
- e. Set the TRIGGERING LEVEL/SLOPE control to +AUTO.

- f. Vertically position the trace to the top graticule line.
- g. Trace deviation from a straight line should not exceed 1/2 minor division.
- h. Vertically position the trace to the bottom graticule line.
- i. Trace deviation from a straight line should not exceed 1/2 minor division.

NOTE

It may be necessary to compromise the setting of R1062 to provide acceptable displays in steps c, g, and i.

14. Adjust Limit Centering (R69 and R269)

Set CH 1 and CH 2 VOLTS/DIV to 5 DIV CAL.

Set Mode to CH 1.

- a. Vertically position the bottom of the display to the first graticule line below the center line.
- b. Reduce the display amplitude to two divisions, using the Var VOLTS/DIV control.
- c. Vertically position the top of the display to the top graticule line and check for compression (decrease in display amplitude).
- d. Vertically position the bottom of the display to the bottom graticule line and check for compression.
- e. ADJUST—R69, Limit Centering control, for least compression. Compression should not exceed 0.1 division. See Fig. 5-13 for location of R69 and R269.
- f. Set Mode switch to CH 2 and repeat steps a through d.
- g. ADJUST—R269, Limit Centering control, for least compression.

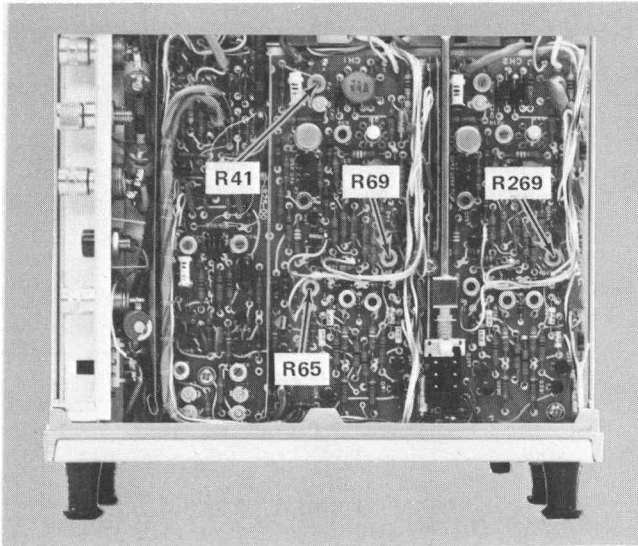

Fig. 5-13. Location of Limit Centering and Vertical Gain controls.

15. Adjust CH 1 Vertical Gain (R65)

Set the 326 controls as follows:

| | |
|----------------|------|
| CH 1 VOLTS/DIV | .01 |
| Var | CAL |
| Mode | CH 1 |
| CH 1—NORM | CH 1 |

- a. Connect the Standard Amplitude Calibrator output to CH 1 VERT INPUT connector via a 50 Ω BNC cable.
- b. Set the Standard Amplitude Calibrator for a 50-mV square-wave output.
- c. Vertically center the display about the center horizontal graticule line.
- d. ADJUST—R65, X1 Vertical Gain adjustment, for 5.00 divisions of display. See Fig. 5-13 for location of Gain controls.

16. Adjust CH 1 X10 Vertical Gain (R41)

- a. Reset the Standard Amplitude Calibrator to 5 mV, and pull the 326 CH 1 X10 VERT GAIN control.
- b. Vertically center the display about the center horizontal graticule line.
- c. ADJUST—R41, Vertical X10 Gain, for 5.00 divisions of display.

17. Adjust CH 2 X1 Vertical Gain (R265)

Reset the following controls:

| | |
|-------------------------------|-------|
| Mode | CH 2 |
| CH 1—NORM | NORM |
| CH 2 VOLTS/DIV | .01 |
| Standard Amplitude Calibrator | 50 mV |

- a. Connect the Standard Amplitude Calibrator output to CH 2 VERT INPUT connector.
- b. Vertically center the display about the center horizontal graticule line.
- c. ADJUST—R265, Vertical X1 Gain, for 5.00 divisions of display.

18. Adjust CH 2 X10 Vertical Gain (R241)

Reset Standard Amplitude Calibrator for 5 mV output and pull CH 2 X10 VERT GAIN control.

- a. Vertically center the display about the center graticule line.
- b. ADJUST—R241, Vert X10 Gain, for exactly 5 divisions of display.

19. Adjust High Frequency Compensation

Reset the following controls:

| | |
|----------------|-----------|
| CH 1 VERT GAIN | pushed in |
| CH 1 VOLTS/DIV | 1 volt |
| Mode | CH 1 |
| CH 1—NORM | CH 1 |
| TIME/DIV | 1 μs |

- a. Connect the Square-Wave Generator Fast-Rise +Output connector to the 326 CH 1 VERT INPUT connector through a GR to BNC adapter; 42-inch, 50 Ω, BNC cable; 50 Ω, 10X, BNC attenuator; and a 50 Ω BNC termination.
- b. Set the Square-Wave Generator for a four-division, 100 kHz display on the 326.
- c. Move the leading edge of the square wave into the viewing area.

d. Set the Test Oscilloscope for 1 Volt/Div and 2 μ s/Div.

e. Connect the Test Oscilloscope 10X probe tip to Q457 collector (case). See Fig. 5-14A for location.

f. ADJUST—R411 for a flat top on the Test Oscilloscope display.

g. Connect the probe tip to Q458 collector.

h. ADJUST—R421 for flat bottom on the Test Oscilloscope display.

i. PULL X10 HORIZ MAG.

j. ADJUST—R418, R428, C417, C427, C418, C428, and R430 for best front corner. See Fig. 5-14B for location of controls.

k. ADJUST—C40, CH 1 Vertical Amp board, for best front corner. See Fig. 5-14B for location of C40 and C240.

l. Move the signal source from CH 1 to CH 2 and switch Mode to CH 2 and TRIGGERING from CH 1 to NORM.

m. ADJUST—C240, CH 2 Vertical Amp board, for best front corner. See Fig. 5-14C for typical waveform indicating correct high frequency adjustment.

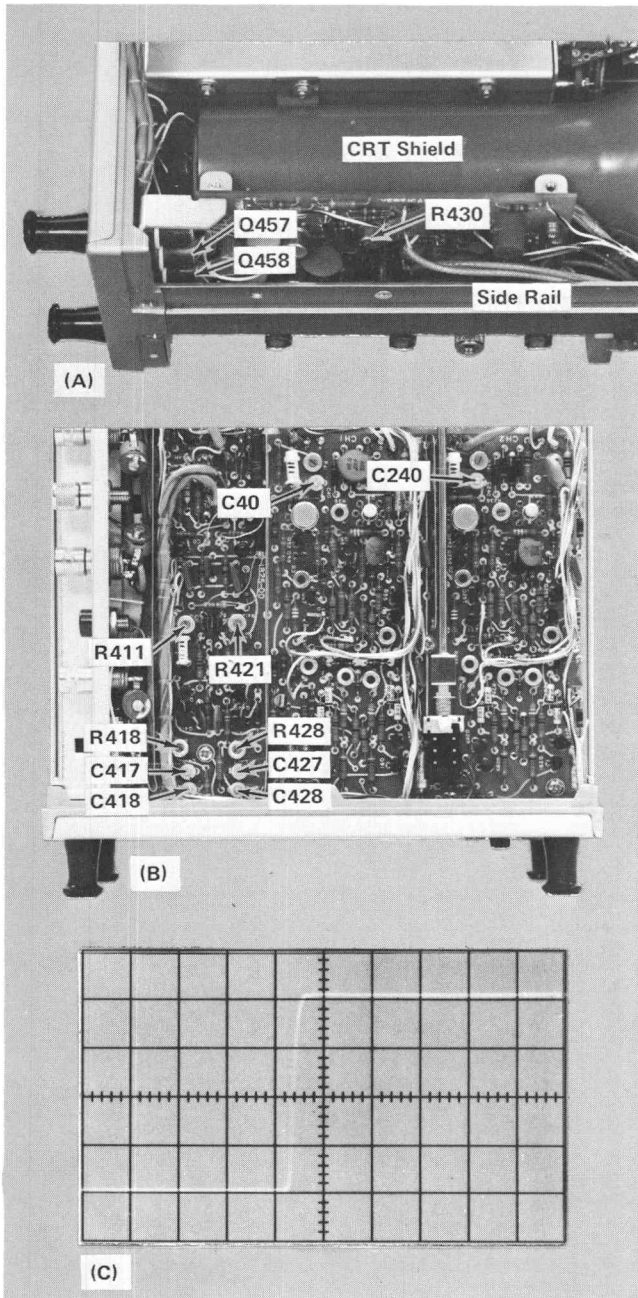

Fig. 5-14. High frequency compensation adjustment. (A) Location of test points, (B) Location of controls, and (C) Typical waveform.

20. Adjust Input Capacitance (C21-C221)

Reset the following 326 controls:

| | |
|---------------------|-------|
| CH 1—CH 2 VOLTS/DIV | .01 |
| Mode | CH 1 |
| TIME/DIV | .5 ms |
| CH 1—NORM | CH 1 |

a. Install the calibration shield on the 326.

b. Connect the Square-Wave Generator High-Amplitude +Output to the CH 1 VERT INPUT connector through a GR to BNC adapter; 42-inch, 50 Ω , BNC cable; 10X, 50 Ω , BNC attenuator; 50 Ω , BNC termination; and 47 pF Input RC Normalizer, in the order given.

c. Set the Square-Wave Generator for a five-division display at 1 kHz.

d. ADJUST—C21 (see Fig. 5-15A for location) for minimum overshoot and rounding of the leading edge of the square wave as shown in Fig. 5-15B.

Reset Mode switch to CH 2. Connect the square-wave signal to CH 2 VERT INPUT. Switch CH 1—NORM to NORM.

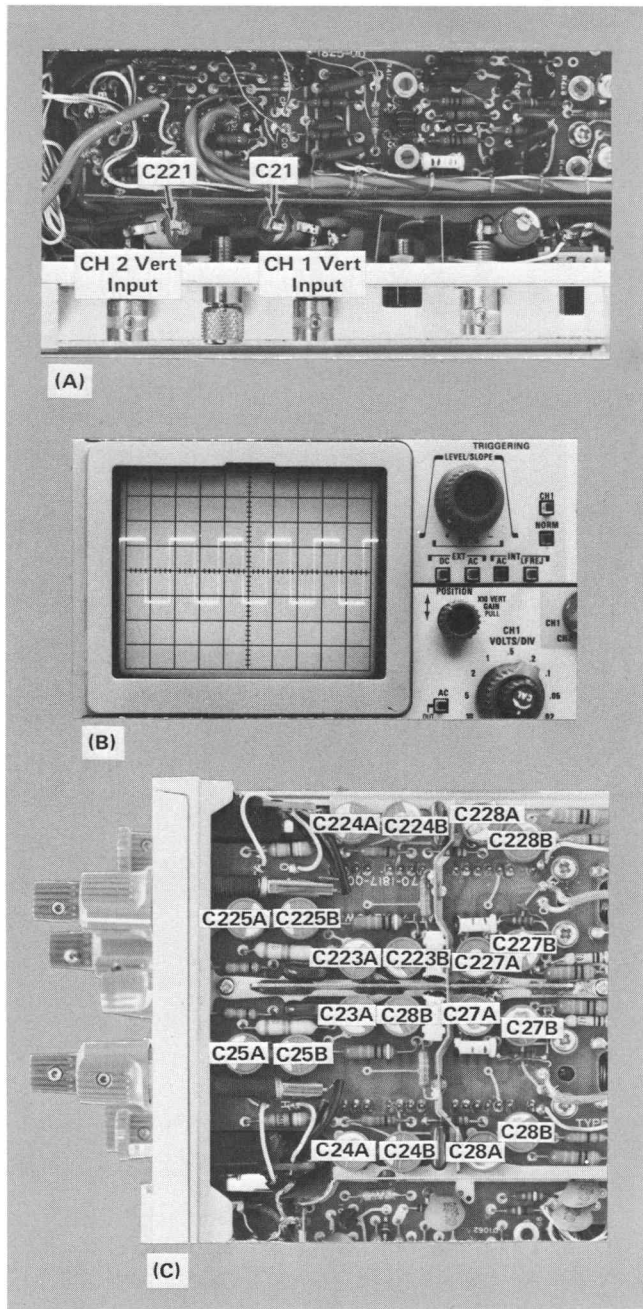

Fig. 5-15. Input capacitance adjustment (A) Location of controls, (B) Typical waveform, and (C) Location of Volts/Div switch compensation.

e. ADJUST—C221 for minimum overshoot and rounding of the leading edge of the square wave as shown in Fig. 5-15B.

f. Remove the signal and the 47 pF Input RC Normalizer.

21. Adjust Volts/Div Switch Compensation

Reset the following 326 controls:

CH 1 VOLTS/DIV 0.1
 CH 1—NORM CH 1

a. Connect the P6049A Probe to the 326 CH 1 VERT INPUT connector.

b. Install a GR to BNC adapter; 10X, 50 Ω, BNC attenuator; and BNC to Binding Post adapter on the Square-Wave Generator High-Amplitude Output connector in the order given.

c. Connect the P6049A Probe tip to the binding post adapter.

d. Set the square wave generator for a five-division display at 1 kHz.

e. Compensate the probe as described in the probe instruction manual.

f. ADJUST and CHECK—VOLTS/DIV switch compensation as detailed in Table 5-5 (use low-capacitance screwdriver). First adjust for best square corner and then for flat top (see Fig. 5-15C for location of controls).

g. Set CH 2 VOLTS/DIV to 0.1 and CH 1—NORM to NORM.

h. Move the probe to CH 2 VERT INPUT and repeat steps d through f for CH 2 (adjust C223 through C228).

TABLE 5-5

VOLTS/DIV Compensation

| VOLTS/DIV Setting | Attenuator Compensated | Adjust for | |
|--------------------------------|------------------------|---|----------|
| | | Square Corner | Flat Top |
| .01 | X1 | Compensate Probe | |
| .02 | X2 | C27B | C27A |
| .05 | X5 | C28B | C28A |
| Remove external 10X attenuator | | | |
| .1 | X10 | C23B | C23A |
| .2 | Check | If out of tolerance, compromise setting at .1 and .2 for best overall response. | |

TABLE 5-5 (cont)

| VOLTS/DIV Setting | Attenuator Compensated | Adjust for | |
|---------------------------|------------------------|--|----------|
| | | Square Corner | Flat Top |
| .5 | Check | If out of tolerance, compromise setting at .1, .2, and .5 for best overall response. | |
| 1 | X100 | C24B | C24A |
| 2 | Check | If out of tolerance, compromise setting at 1 and 2 for best overall response. | |
| Pull 10X VERT GAIN switch | | | |
| 5 | Check | If out of tolerance, compromise setting at 1, 2, and 5 for best overall response. | |
| 10 | X200 | C25B | C25A |

- i. Disconnect all test equipment.
- j. Remove Calibration Shield.

22. Adjust Magnified Registration (R713)

Reset the following controls:

| | |
|------------|------|
| VOLTS/DIV | .5 |
| CH 1 INPUT | DC |
| Mode | CH 1 |
| CH 1—NORM | CH 1 |

a. Connect the Time-Mark Generator to CH 1 VERT INPUT connector through a 42-inch, 50 Ω, BNC cable and a 50 Ω termination.

b. Set the Time-Mark Generator for 5 ms markers and set the 326 TRIGGERING controls for a stable display.

c. Position the middle marker (three markers displayed) to the center vertical graticule line.

d. Pull the X10 HORIZ MAG switch. To prevent changing knob position (rotational) the X10 HORIZ MAG switch can be actuated using the Horizontal Position control bracket behind the front panel.

e. ADJUST—R713 (see Fig. 5-16A for location) to position the middle marker to the center vertical line.

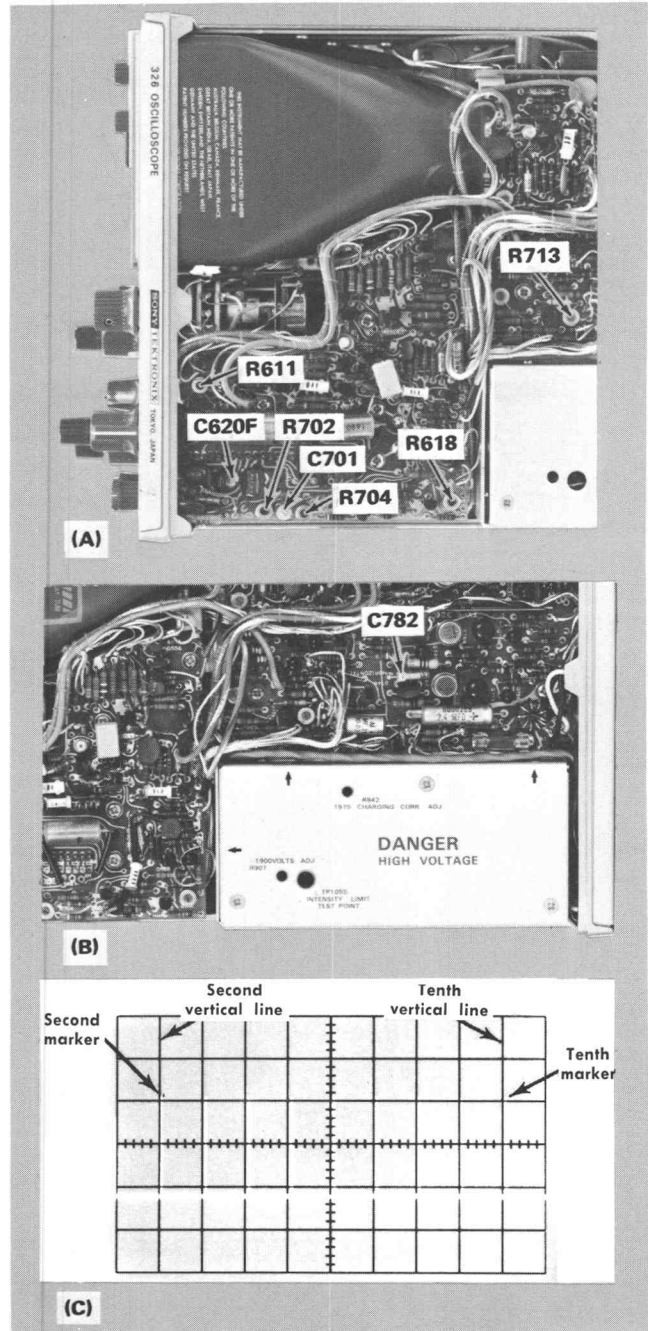

Fig. 5-16. Timing Adjustments (A) (B) Location of controls and (C) Typical waveform.

f. Push the X10 HORIZ MAG switch in.

23. Adjust Normal Timing

a. Set R611 (see Fig. 5-16B) midway between just triggered display and auto sweep (remove signal to determine auto sweep).

Performance Check/Adjustment—326

- b. Set the Time-Mark Generator for 1 ms markers.
- c. Set TRIGGERING controls for stable display.

NOTE

Unless otherwise noted, use the middle eight horizontal divisions (between the second and tenth vertical graticule lines) when checking or adjusting timing.

d. ADJUST—R702, X1 Gain (see Fig. 5-16A for location) for one marker per division over the center eight divisions. The first and ninth markers must coincide exactly with their respective graticule lines (reposition horizontally as needed). See Fig. 5-17.

24. Adjust Sweep Length and Centering (R618-R704)

- a. Adjust the TRIGGERING controls for a stable display.
- b. Set the tenth marker (see Fig. 5-17B) to the tenth vertical graticule line.
- c. ADJUST—R618, Sweep Length adjustment, for a sweep length of 10.7 divisions (0.7 division of display to the right of the tenth marker).
- d. Turn the Horizontal POSITION control fully clockwise.

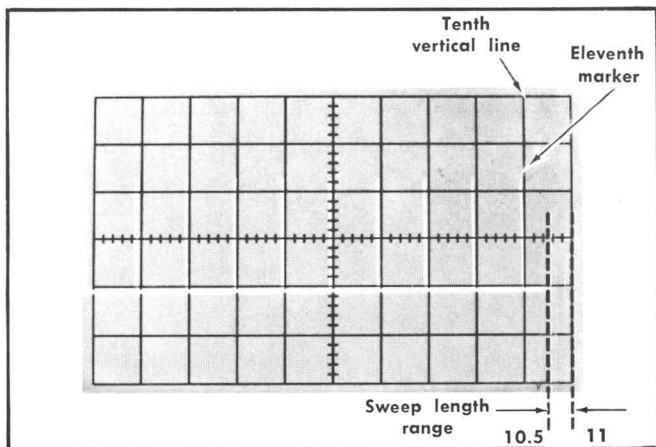

Fig. 5-17. Adjusting sweep length and centering. Typical waveform.

e. ADJUST—R704, Position Centering, to move the first marker two and one-half divisions to the right of graticule center.

f. Turn the Horizontal POSITION control fully counter-clockwise and check for approximately two and one-half divisions from end of trace to graticule center.

g. ADJUST—R704 (if necessary) to set the distance from trace start to the center graticule line equal to the distance from end of trace to graticule center.

h. INTERACTION—R702 may have to be readjusted slightly to correct timing.

25. Adjust Magnified Timing (R717)

- a. Set the Time-Mark Generator for .1 ms markers.
- b. Set the 326 Horizontal POSITION control to mid-range and pull the X10 HORIZ MAG knob.
- c. ADJUST—R717, X10 Gain adjustment, for one marker per division over the center eight divisions. The second and tenth markers must coincide exactly with their respective graticule lines.

26. Adjust High Speed Timing

Reset the following 326 controls:

| | |
|---------------------|-----------|
| TIME/DIV | 1 μ s |
| X10 HORIZ MAG | PULL |
| Horizontal POSITION | midrange |

Set the Time Mark Generator for .1 μ s markers.

- a. Observe approximately 1 marker per division displayed on 326.
- b. ADJUST—C620F for best timing (1 marker per division).
- c. Horizontally position the trace start to the viewing area.
- d. ADJUST—C701 for best sweep start linearity.

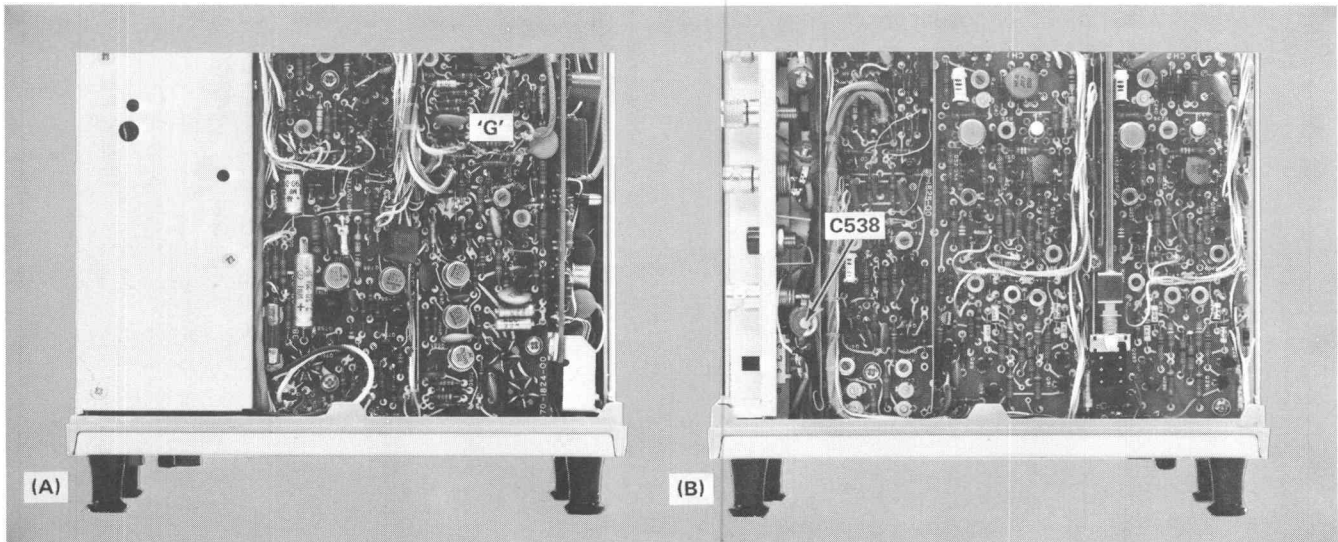

Fig. 5-18. Location of (A) Ext Horiz 10X Compensation test point 'G' and (B) C538.

e. Horizontally position the end of trace to the viewing area.

f. ADJUST—C782 for best sweep end linearity. See Fig. 5-16A and B for location of controls.

27. Adjust External Horizontal 10X Compensation (C538)

Set the 326 controls as follows:

| | |
|---------------------------------|-----------|
| TIME/DIV | EXT HORIZ |
| TRIGGERING | EXT DC |
| HORIZ MAG | Pushed in |
| EXT HORIZ ATTEN (side panel) | X 10 |

a. Connect the Standard Amplitude Calibrator to EXT TRIG OR HORIZ INPUT. Set Standard Amplitude Calibrator for a 5-volt square wave.

b. Connect a properly compensated probe to the Test Oscilloscope Input.

c. Set the Test Oscilloscope for a vertical deflection factor of .02 Volt/Div and a sweep rate of .5 ms/Div.

d. Connect the probe tip to point G on the 326 Horizontal Circuit board (see Fig. 5-18A for location).

e. ADJUST—C538 (see Fig. 5-18B) for the best square wave (minimum rounding or overshoot). Use a low capacitance screwdriver.

28. Adjust Battery Charger Charge Rate

a. Plug the battery charger banana plugs into the battery pack jacks, being sure that polarity is correct (mount the charger in the same position, relative to the battery pack, that it would be in if charging the battery pack in the instrument).

b. Connect a banana-banana patchcord from the negative battery pack output terminal to the negative external DC supply banana plug. See Fig. 5-19.

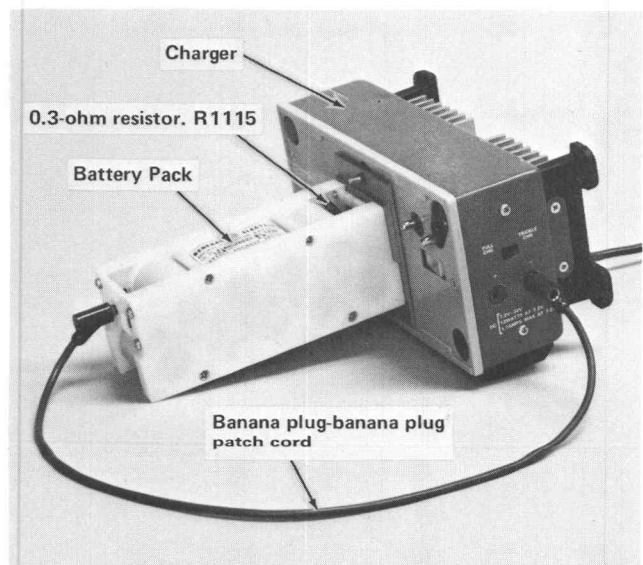

Fig. 5-19. Ground connection required to charge Battery Pack outside of instrument.

Performance Check/Adjustment—326

c. Connect a precision DC voltmeter across the 0.3-ohm resistor (R1115) in the battery pack.

d. Set the FULL CHG—TRICKLE switch to FULL CHG.

e. Plug the AC power cord into the variable line voltage source set to 115 volts.

f. ADJUST—R1144 for 0.45 volt (150 mA charge rate) across R1115 (0.3 ohms).

g. Vary the line voltage between 90 and 136 volts.

h. CHECK—Voltage drop across R1115 should not vary more than ± 5 mV.

i. Switch the FULL CHG—TRICKLE switch to TRICKLE.

j. CHECK—For 16 mV, ± 2 mV, across R1115.

SECTION 6 ELECTRICAL PARTS LIST

Replacement parts should be ordered from the Tektronix Field Office or Representative in your area. Changes to Tektronix products give you the benefit of improved circuits and components. Please include the instrument type number and serial number with each order for parts or service.

ABBREVIATIONS AND REFERENCE DESIGNATORS

| | | | | | |
|--------|-----------------------------------|-----|--|-----|---|
| A | Assembly, separable or repairable | FL | Filter | PTM | paper or plastic, tubular molded |
| AT | Attenuator, fixed or variable | H | Heat dissipating device (heat sink, etc.) | R | Resistor, fixed or variable |
| B | Motor | HR | Heater | RT | Thermistor |
| BT | Battery | J | Connector, stationary portion | S | Switch |
| C | Capacitor, fixed or variable | K | Relay | T | Transformer |
| Cer | Ceramic | L | Inductor, fixed or variable | TP | Test point |
| CR | Diode, signal or rectifier | LR | Inductor/resistor combination | U | Assembly, inseparable or non-repairable |
| CRT | cathode-ray tube | M | Meter | V | Electron tube |
| DL | Delay line | Q | Transistor or silicon-controlled rectifier | Var | Variable |
| DS | Indicating device (lamp) | P | Connector, movable portion | VR | Voltage regulator (zener diode, etc.) |
| Elect. | Electrolytic | PMC | Paper, metal cased | WW | wire-wound |
| EMC | electrolytic, metal cased | PT | paper, tubular | Y | Crystal |
| EMT | electrolytic, metal tubular | | | | |
| F | Fuse | | | | |

| Ckt. No. | Tektronix Part No. | Serial/Model No. Eff | Disc | Description |
|-------------------|--------------------|----------------------|------|--|
| ASSEMBLY | | | | |
| A1 | 670-1829-00 | | | CH 1 AC-DC Circuit Board Assembly |
| A2 | 670-1830-00 | | | CH 2 AC-DC Circuit Board Assembly |
| A3 | 670-1825-00 | | | VERTICAL PREAMP. Circuit Board Assembly |
| A4 | 670-1817-00 | | | ATTEN-CAL-SWITCHING Circuit Board Assembly |
| A5 | 670-1823-00 | | | VERTICAL OUTPUT Circuit Board Assembly |
| A6 | 670-1827-00 | | | TRIGGER SOURCE Circuit Board Assembly |
| A7 | 670-1828-00 | | | TRIGGER SOURCE COUPLING Circuit Board Assembly |
| A8 | 670-1818-00 | | | TRIGGER-SWEEP Circuit Board Assembly |
| A9 | 670-1819-00 | | | TIMING Circuit Board Assembly |
| A10 | 670-1824-00 | | | HORIZONTAL Circuit Board Assembly |
| A11 | 670-1821-00 | | | POWER REGULATOR-RECTIFIER Circuit Board Assembly |
| A12 | 670-1820-00 | | | POWER REGULATOR-H. V. Circuit Board Assembly |
| A13 | 670-1822-00 | | | POWER REGULATOR-CONTROL Circuit Board Assembly |
| A14 | 670-1826-00 | | | BATTERY CHARGER Circuit Board Assembly |
| BATTERY | | | | |
| AT1115 | 146-0018-00 | | | Battery, set of 9 NiCd cells |
| CAPACITORS | | | | |
| C1 | 283-0059-00 | | | 1 μ F, Cer, 25 V, +80%-20% |
| C2 | 283-0059-00 | | | 1 μ F, Cer, 25 V, +80%-20% |
| C3 | 290-0183-01 | | | 1 μ F, Elect., 35 V, 10% |
| C5 | 283-0023-00 | | | 0.1 μ F, Cer, 10 V, +80%-20% |
| C6 | 290-0183-01 | | | 1 μ F, Elect., 35 V, 10% |
| C7 | 290-0114-02 | | | 47 μ F, Elect., 6 V, 10% |
| C8 | 290-0114-02 | | | 47 μ F, Elect., 6 V, 10% |
| C19 | 283-0003-00 | | | 0.01 μ F, Cer, 150 V, +80%-20% |
| C20 | 285-0841-00 | | | 0.0185 μ F, PTM, 500 V, 10% |
| C23A | 281-0093-01 | | | 5.5-18 pF, Var, Cer |

ELECTRICAL PARTS LIST (cont)

| Ckt. No. | Tektronix Part No. | Serial/Model No. Eff | Disc | Description |
|-------------------|--------------------|----------------------|------|------------------------------------|
| CAPACITORS (cont) | | | | |
| C23B | 281-0091-01 | | | 2-8 pF, Var, Cer |
| C23C | 281-0600-00 | | | 35 pF, Cer, 10% |
| C24A | 281-0093-01 | | | 5.5-18 pF, Var, Cer |
| C24B | 281-0091-01 | | | 2-8 pF, Var, Cer |
| C24C | 283-0597-01 | | | 470 pF, Mica, 300 V, 10% |
| C25A | 281-0093-01 | | | 5.5-18 pF, Var, Cer |
| C25B | 281-0091-01 | | | 2-8 pF, Var, Cer |
| C25C | 283-0685-00 | | | 1000 pF, Mica, 300 V, 10% |
| C27A | 281-0091-01 | | | 2-8 pF, Var, Cer |
| C27B | 281-0093-01 | | | 5.5-18 pF, Var, Cer |
| C27C | 281-0592-00 | | | 4.7 pF, Cer, ± 0.5 pF |
| C27D | 283-0201-00 | | | 27 pF, Cer, 200 V, 10% |
| C28A | 281-0093-01 | | | 5.5-18 pF, Var, Cer |
| C28B | 281-0091-01 | | | 2-8 pF, Var, Cer |
| C30 | 283-0068-00 | | | 0.01 μ F, Cer, 500 V, +100%-0% |
| C31 | 290-0183-01 | | | 1 μ F, Elect., 35 V, 10% |
| C40 | 281-0122-00 | | | 2.5-9 pF, Var, Cer, 100 V |
| C41 | 281-0622-00 | | | 47 pF, Cer, 500 V, 1% |
| C48 | 283-0003-00 | | | 0.01 μ F, Cer, 150 V, +80%-20% |
| C95 | 283-0003-00 | | | 0.01 μ F, Cer, 150 V, +80%-20% |
| C201 | 283-0059-00 | | | 1 μ F, Cer, 25 V, +80%-20% |
| C202 | 283-0059-00 | | | 1 μ F, Cer, 25 V, +80%-20% |
| C207 | 290-0114-02 | | | 47 μ F, Elect., 6 V, 10% |
| C208 | 290-0114-02 | | | 47 μ F, Elect., 6 V, 10% |
| C220 | 285-0841-00 | | | 0.0185 μ F, PTM, 500 V, 10% |
| C223A | 281-0093-01 | | | 5.5-18 pF, Var, Cer |
| C223B | 281-0091-01 | | | 2-8 pF, Var, Cer |
| C223C | 281-0600-00 | | | 35 pF, Cer, 10% |
| C224A | 281-0093-01 | | | 5.5-18 pF, Var, Cer |
| C224B | 281-0091-01 | | | 2-8 pF, Var, Cer |
| C224C | 283-0597-01 | | | 470 pF, Mica, 300 V, 10% |
| C225A | 281-0093-01 | | | 5.5-18 pF, Var, Cer |
| C225B | 281-0091-01 | | | 2-8 pF, Var, Cer |
| C225C | 283-0685-00 | | | 1000 pF, Mica, 300 V, 10% |
| C227A | 281-0091-01 | | | 2-8 pF, Var, Cer |
| C227B | 281-0093-01 | | | 5.5-18 pF, Var, Cer |
| C227C | 281-0592-00 | | | 4.7 pF, Cer, ± 0.5 pF |
| C227D | 283-0201-00 | | | 27 pF, Cer, 200 V, 10% |
| C228A | 281-0093-01 | | | 5.5-18 pF, Var, Cer |
| C228B | 281-0091-01 | | | 2-8 pF, Var, Cer |
| C230 | 283-0068-00 | | | 0.01 μ F, Cer, 500 V, +100%-0% |
| C231 | 290-0183-01 | | | 1 μ F, Elect., 35 V, 10% |
| C240 | 281-0122-00 | | | 2.5-9 pF, Var, Cer |
| C241 | 281-0622-00 | | | 47 pF, Cer, 500 V, 1% |
| C248 | 283-0003-00 | | | 0.01 μ F, Cer, 150 V, +80%-20% |
| C332 | 283-0028-00 | | | 0.0022 μ F, Cer, 50 V |
| C334 | 285-0685-00 | | | 0.0068 μ F, PTM, 100 V, 10% |
| C335 | 281-0518-00 | | | 47 pF, Cer, 500 V, 20% |
| C342 | 283-0028-00 | | | 0.0022 μ F, Cer, 50 V |
| C345 | 281-0518-00 | | | 47 pF, Cer, 500 V, 20% |

ELECTRICAL PARTS LIST (cont)

| Ckt. No. | Tektronix Part No. | Serial/Model No. Eff | Disc | Description |
|-------------------|--------------------|----------------------|--------|------------------------------------|
| CAPACITORS (cont) | | | | |
| C350 | 290-0183-01 | | | 1 μ F, Elect., 35 V, 10% |
| C352 | 283-0230-00 | | | 470 pF, Cer, 500 V, 20% |
| C361 | 283-0003-00 | 300000 | 300025 | 0.01 μ F, Cer, 150 V, +80%-20% |
| C361 | 283-0059-00 | 300026 | | 1 μ F, Cer, 25 V, +80%-20% |
| C397 | 283-0111-00 | | | 0.1 μ F, Cer, 50 V |
| C400 | 283-0003-00 | | | 0.01 μ F, Cer, 150 V, +80%-20% |
| C411 | 281-0630-00 | | | 390 pF, Cer, 500 V, 5% |
| C413 | 283-0231-00 | | | 470 pF, Cer, 500 V, 10% |
| C417 | 281-0123-00 | | | 5-25 pF, Var, Cer, 100 V |
| C418 | 281-0122-00 | | | 2.5-9 pF, Var, Cer, 100 V |
| C421 | 281-0630-00 | | | 390 pF, Cer, 500 V, 5% |
| C427 | 281-0123-00 | | | 5-25 pF, Var, Cer, 100 V |
| C428 | 281-0122-00 | | | 2.5-9 pF, Var, Cer, 100 V |
| C444 | 283-0230-00 | | | 470 pF, Cer, 500 V, 20% |
| C446 | 283-0230-00 | | | 470 pF, Cer, 500 V, 20% |
| C449 | 283-0237-00 | | | 0.1 μ F, Cer, 25 V, +80%-20% |
| C452 | 283-0237-00 | | | 0.1 μ F, Cer, 25 V, +80%-20% |
| C454 | 283-0237-00 | | | 0.1 μ F, Cer, 25 V, +80%-20% |
| C457 | 283-0059-00 | | | 1 μ F, Cer, 25 V, +80%-20% |
| C458 | 283-0059-00 | | | 1 μ F, Cer, 25 V, +80%-20% |
| C460 | 281-0724-00 | | | 0.3 pF, Cer, 500 V, 10% |
| C462 | 283-0235-00 | | | 0.05 μ F, Cer, 50 V, +100%-0% |
| C464 | 283-0068-00 | | | 0.01 μ F, Cer, 500 V, +100%-0% |
| C470 | 281-0724-00 | | | 0.3 pF, Cer, 500 V, 10% |
| C472 | 283-0235-00 | | | 0.05 μ F, Cer, 50 V, +100%-0% |
| C474 | 283-0068-00 | | | 0.01 μ F, Cer, 500 V, +100%-0% |
| C476 | 283-0059-00 | | | 1 μ F, Cer, 25 V, +80%-20% |
| C478 | 283-0059-00 | | | 1 μ F, Cer, 25 V, +80%-20% |
| C480 | 290-0271-00 | | | 9 μ F, Elect., 125 V, +20%-15% |
| C508 | 283-0288-00 | | | 35 pF, Cer, 500 V, 10% |
| C510 | 283-0003-00 | | | 0.01 μ F, Cer, 150 V, +80%-20% |
| C540 | 283-0068-00 | | | 0.01 μ F, Cer, 500 V, +100%-0% |
| C542 | 283-0104-01 | | | 0.002 μ F, Cer, 500 V, 5% |
| C549 | 283-0067-00 | | | 0.001 μ F, Cer, 200 V, 10% |
| C555 | 283-0247-00 | | | 680 pF, Cer, 500 V, 10% |
| C558 | 283-0024-00 | | | 0.1 μ F, Cer, 30 V, +80%-20% |
| C565A | 290-0460-00 | | | 10 μ F, Elect., 25 V, 20% |
| C565B | 290-0183-01 | | | 1 μ F, Elect., 35 V, 10% |
| C565C | 290-0450-00 | | | 0.1 μ F, Elect., 35 V, 20% |

ELECTRICAL PARTS LIST (cont)

| Ckt. No. | Tektronix Part No. | Serial/Model No. Eff | Disc | Description |
|-------------------|--------------------|----------------------|------|------------------------------------|
| CAPACITORS (cont) | | | | |
| C566 | 283-0228-00 | | | 51 pF, Cer, 50 V, 10% |
| C572 | 283-0228-00 | | | 51 pF, Cer, 50 V, 10% |
| C590 | 290-0457-00 | | | 4.7 μ F, Elect., 10 V, 20% |
| C595 | 290-0457-00 | | | 4.7 μ F, Elect., 10 V, 20% |
| C611 | 281-0578-00 | | | 18 pF, Cer, 500 V, 5% |
| C615 ¹ | 283-0231-00 | | | 470 pF, Cer, 500 V, 10% |
| C616 ¹ | 283-0236-00 | X300026 | | 0.01 μ F, Cer, 50 V, 20% |
| C620A | 295-0134-00 | | | 1 μ F, |
| C620B | | | | 0.1 μ F, Timing capacitor |
| C620C | | | | 0.01 μ F, |
| C620D | | | | 0.001 μ F, |
| C620E | 283-0720-00 | | | 275 pF, Mica, 500 V, 1% |
| C620F | 281-0123-00 | | | 5-25 pF, Var, Cer, 100 V |
| C626 | 283-0282-00 | | | 100 pF, Cer, 500 V, 20% |
| C628 | 281-0503-00 | | | 8 pF, Cer, 500 V, ± 0.5 pF |
| C630 | 281-0622-00 | | | 47 pF, Cer, 500 V, 1% |
| C635 | 283-0224-00 | | | 5 pF, Cer, 50 V, ± 0.5 pF |
| C636 | 283-0231-00 | | | 470 pF, Cer, 500 V, 10% |
| C642 | 290-0136-01 | | | 2.2 μ F, Elect., 20 V, 20% |
| C644 | 283-0236-00 | | | 0.01 μ F, Cer, 50 V, 20% |
| C648 | 290-0136-01 | | | 2.2 μ F, Elect., 20 V, 20% |
| C650 | 281-0550-00 | | | 120 pF, Cer, 500 V, 10% |
| C655 | 290-0134-02 | | | 22 μ F, Elect., 15 V, +20%-0% |
| C660A | 290-0167-01 | | | 10 μ F, Elect., 15 V |
| C660B | 283-0203-00 | | | 0.47 μ F, Cer, 50 V, 20% |
| C661 | 283-0232-00 | | | 0.001 μ F, Cer, 50 V, 20% |
| C663 | 281-0523-00 | | | 100 pF, Cer, 350 V, 10% |
| C671 | 283-0675-01 | | | 82 pF, Mica, 300 V, 1% |
| C672 | 290-0136-01 | | | 2.2 μ F, Elect., 20 V, 20% |
| C679 | 283-0003-00 | | | 0.01 μ F, Cer, 150 V, +80%-20% |
| C684 | 283-0231-00 | | | 470 pF, Cer, 500 V, 10% |
| C686 | 283-0236-00 | | | 0.01 μ F, Cer, 50 V, 20% |
| C687 | 283-0230-00 | | | 470 pF, Cer, 50 V, 20% |
| C694 | 283-0068-00 | | | 0.01 μ F, Cer, 500 V, +100%-0% |
| C695 | 290-0457-00 | | | 4.7 μ F, Elect., 10 V, 20% |

¹Individual timing capacitors in this assembly must be ordered by the 9 digit part number, letter suffix and tolerance printed on the timing capacitor to be replaced.

Example:

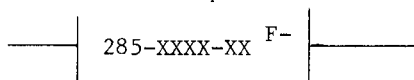

The letter suffix and the tolerance should be the same for all of the timing capacitors in the assembly.

ELECTRICAL PARTS LIST (cont)

| Ckt. No. | Tektronix Part No. | Serial/Model No. Eff | Disc | Description |
|-------------------|--------------------|----------------------|------|-------------------------------------|
| CAPACITORS (cont) | | | | |
| C696 | 290-0457-00 | | | 4.7 μ F, Elect., 10 V, 20% |
| C701 | 281-0123-00 | | | 5-25 pF, Var, Cer, 100 V |
| C702 | 281-0523-00 | | | 100 pF, Cer, 350 V, 10% |
| C705 | 283-0597-01 | | | 470 pF, Mica, 300 V, 10% |
| C722 | 281-0103-00 | | | 180 pF, Cer, 500 V, 5% |
| C736 | 283-0230-00 | | | 470 pF, Cer, 500 V, 20% |
| C750 | 283-0241-00 | | | 0.2 pF, Cer, 500 V, 20% |
| C754 | 283-0233-00 | | | 0.0022 μ F, Cer, 500 V, 20% |
| C760 | 290-0449-00 | | | 3 μ F, Elect., 250 V, +100%-0% |
| C762 | 283-0231-00 | | | 470 pF, Cer, 500 V, 10% |
| C763 | 281-0622-00 | X300026 | | 47 pF, Cer, 500 V, 1% |
| C764 | 283-0079-00 | | | 0.01 μ F, Cer, 250 V, 20% |
| C782 | 281-0095-00 | | | 0.2-1.5 pF, Var, Teflon |
| C784 | 283-0240-00 | | | 1 pF, Cer, 500 V, 20% |
| C791 | 290-0114-01 | | | 47 μ F, Elect., 6 V |
| C792 | 290-0114-01 | | | 47 μ F, Elect., 6 V |
| C870B | 290-0562-00 | | | 210 μ F, Elect., 40 V, +75%-10% |
| C878 | 290-0164-00 | | | 1 μ F, Elect., 150 V |
| C892 | 283-0231-00 | | | 470 pF, Cer, 500 V, 10% |
| C894 | 283-0597-01 | | | 470 pF, Mica, 300 V, 10% |
| C896 | 283-0597-01 | | | 470 pF, Mica, 300 V, 10% |
| C898 | 290-0136-01 | | | 2.2 μ F, Elect., 20 V, 20% |
| C905 | 283-0000-01 | | | 0.001 μ F, Cer, 500 V, +100%-0% |
| C910 | 283-0111-00 | | | 0.1 μ F, Cer, 50 V, |
| C958 | 290-0167-01 | | | 10 μ F, Elect., 15 V |
| C959 | 290-0565-00 | | | 150 μ F, Elect., 6.3 V, 10% |
| C962 | 290-0167-01 | | | 10 μ F, Elect., 15 V |
| C964 | 290-0183-01 | | | 1 μ F, Elect., 35 V, 10% |
| C966 | 290-0183-01 | | | 1 μ F, Elect., 35 V, 10% |
| C990 | 290-0449-00 | | | 3 μ F, Elect., 250 V, +100%-0% |
| C992 | 290-0563-00 | | | 18 μ F, Elect., +50%-10% |
| C994 | 290-0463-00 | | | 47 μ F, Elect., 20 V, 20% |
| C1000 | 290-0564-00 | | | 560 μ F, Elect., 7 V, +75%-10% |
| C1008 | 283-0003-00 | | | 0.01 μ F, Cer, 150 V, +80%-20% |
| C1014 | 290-0134-01 | | | 22 μ F, Elect., 15 V, 20% |
| C1016 | 290-0564-00 | | | 560 μ F, Elect., 7 V, +75%-10% |
| C1022 | 283-0003-00 | | | 0.01 μ F, Cer, 150 V, +80%-20% |
| C1026 | 283-0003-00 | | | 0.01 μ F, Cer, 150 V, +80%-20% |
| C1032 | 290-0134-01 | | | 22 μ F, Elect., 15 V, 20%-0% |
| C1040 | (7) 283-0151-00 | | | 0.01 μ F, Cer, 500 V |
| C1041 | (7) 283-0151-00 | | | 0.01 μ F, Cer, 500 V |
| C1042 | (7) 283-0151-00 | | | 0.01 μ F, Cer, 500 V |

ELECTRICAL PARTS LIST (cont)

| Ckt. No. | Tektronix Part No. | Serial/Model No. Eff | Disc | Description |
|-------------------|--------------------|----------------------|--------|---|
| CAPACITORS (cont) | | | | |
| C1046 | 283-0293-00 | | | 0.05 μ F, Cer, 1000 V, +100%-0% |
| C1048 | 283-0293-00 | | | 0.05 μ F, Cer, 1000 V, +100%-0% |
| C1050 | 283-0068-00 | | | 0.01 μ F, Cer, 500 V, +100%-0% |
| C1052 | 283-0292-00 | | | 0.04 μ F, Cer, 2000 V, +100%-0% |
| C1055 | 283-0177-00 | | | 1 μ F, Cer, 25 V, +80%-20% |
| C1062 | 283-0003-00 | | | 0.01 μ F, Cer, 150 V, +80%-20% |
| C1068 | 283-0003-00 | | | 0.01 μ F, Cer, 150 V, +80%-20% |
| C1105 | 290-0287-00 | | | 47 μ F, Elect., 25 V, 20% |
| C1123 | 283-0003-00 | 300000 | 300065 | 0.01 μ F, Cer, 150 V, +80%-20% |
| C1123 | 283-0110-00 | 300066 | | 0.005 μ F, Cer, 150 V |
| C1136 | 290-0114-01 | | | 47 μ F, Elect., 6 V |
| DIODES | | | | |
| CR11 | 152-0327-00 | | | 50 V, 75 mA, BAX 13 |
| CR12 | 152-0327-00 | | | 50 V, 75 mA, BAX 13 |
| CR13 | 152-0327-00 | | | 50 V, 75 mA, BAX 13 |
| CR30 | 152-0246-00 | | | Silicon, replaceable by CD12676 or FD3375 |
| CR31 | 152-0246-00 | | | Silicon, replaceable by CD12676 or FD3375 |
| CR32 | 152-0246-00 | | | Silicon, replaceable by CD12676 or FD3375 |
| CR33 | 152-0246-00 | | | Silicon, replaceable by CD12676 or FD3375 |
| CR50A | 152-0327-00 | | | 50 V, 75 mA, BAX 13 |
| CR50B | 152-0327-00 | | | 50 V, 75 mA, BAX 13 |
| CR74 | 152-0327-00 | | | 50 V, 75 mA, BAX 13 |
| CR75 | 152-0327-00 | | | 50 V, 75 mA, BAX 13 |
| CR76 | 152-0327-00 | | | 50 V, 75 mA, BAX 13 |
| CR77 | 152-0327-00 | | | 50 V, 75 mA, BAX 13 |
| CR79 | 152-0327-00 | | | 50 V, 75 mA, BAX 13 |
| CR80 | 152-0071-00 | | | Germanium, selected from ED-2007 |
| CR81 | 152-0071-00 | | | Germanium, selected from ED-2007 |
| CR82 | 152-0327-00 | | | 50 V, 75 mA, BAX 13 |
| CR83 | 152-0071-00 | | | Germanium, selected from ED-2007 |
| CR84 | 152-0071-00 | | | Germanium, selected from ED-2007 |
| CR86 | 152-0327-00 | | | 50 V, 75 mA, BAX 13 |
| CR230 | 152-0246-00 | | | Silicon, replaceable by CD12676 or FD3375 |
| CR231 | 152-0246-00 | | | Silicon, replaceable by CD12676 or FD3375 |
| CR232 | 152-0246-00 | | | Silicon, replaceable by CD12676 or FD3375 |
| CR233 | 152-0246-00 | | | Silicon, replaceable by CD12676 or FD3375 |
| CR250A | 152-0327-00 | | | 50 V, 75 mA, BAX 13 |
| CR250B | 152-0327-00 | | | 50 V, 75 mA, BAX 13 |
| CR274 | 152-0327-00 | | | 50 V, 75 mA, BAX 13 |
| CR275 | 152-0327-00 | | | 50 V, 75 mA, BAX 13 |
| CR276 | 152-0327-00 | | | 50 V, 75 mA, BAX 13 |
| CR277 | 152-0327-00 | | | 50 V, 75 mA, BAX 13 |

ELECTRICAL PARTS LIST (cont)

| Ckt. No. | Tektronix Part No. | Serial/Model No. Eff | Disc | Description |
|---------------|--------------------|----------------------|------|---|
| DIODES (cont) | | | | |
| CR279 | 152-0327-00 | | | 50 V, 75 mA, BAX 13 |
| CR280 | 152-0071-00 | | | Germanium, selected from ED-2007 |
| CR281 | 152-0071-00 | | | Germanium, selected from ED-2007 |
| CR282 | 152-0327-00 | | | 50 V, 75 mA, BAX 13 |
| CR283 | 152-0071-00 | | | Germanium, selected from ED-2007 |
| CR284 | 152-0071-00 | | | Germanium, selected from ED-2007 |
| CR286 | 152-0327-00 | | | 50 V, 75 mA, BAX 13 |
| CR310 | 152-0141-02 | | | Silicon, replaceable by 1N4152 |
| CR311 | 152-0141-02 | | | Silicon, replaceable by 1N4152 |
| CR312 | 152-0141-02 | | | Silicon, replaceable by 1N4152 |
| CR313 | 152-0141-02 | | | Silicon, replaceable by 1N4152 |
| CR315 | 152-0141-02 | | | Silicon, replaceable by 1N4152 |
| CR316 | 152-0141-02 | | | Silicon, replaceable by 1N4152 |
| CR317 | 152-0141-02 | | | Silicon, replaceable by 1N4152 |
| CR318 | 152-0141-02 | | | Silicon, replaceable by 1N4152 |
| CR331 | 152-0327-00 | | | 50 V, 75 mA, BAX 13 |
| CR335 | 152-0327-00 | | | 50 V, 75 mA, BAX 13 |
| CR341 | 152-0327-00 | | | 50 V, 75 mA, BAX 13 |
| CR345 | 152-0327-00 | | | 50 V, 75 mA, BAX 13 |
| CR400A | 152-0327-00 | | | 50 V, 75 mA, BAX 13 |
| CR400B | 152-0327-00 | | | 50 V, 75 mA, BAX 13 |
| CR400C | 152-0327-00 | | | 50 V, 75 mA, BAX 13 |
| CR440 | 152-0327-00 | | | 50 V, 75 mA, BAX 13 |
| CR442 | 152-0327-00 | | | 50 V, 75 mA, BAX 13 |
| CR542 | 152-0246-00 | | | Silicon, replaceable by CD12676 or FD3375 |
| CR543 | 152-0246-00 | | | Silicon, replaceable by CD12676 or FD3375 |
| CR611 | 152-0327-00 | | | 50 V, 75 mA, BAX 13 |
| CR612 | 152-0327-00 | | | 50 V, 75 mA, BAX 13 |
| CR613 | 152-0327-00 | | | 50 V, 75 mA, BAX 13 |
| CR614 | 152-0327-00 | | | 50 V, 75 mA, BAX 13 |
| CR616 | 152-0327-00 | | | 50 V, 75 mA, BAX 13 |
| CR620 | 152-0249-00 | | | Silicon, replaceable by CD61165 and CD12676 |
| CR626 | 152-0327-00 | | | 50 V, 75 mA, BAX 13 |
| CR628 | 152-0246-00 | | | Silicon, replaceable by CD12676 or FD3375 |
| CR636A | 152-0327-00 | | | 50 V, 75 mA, BAX 13 |
| CR636B | 152-0327-00 | | | 50 V, 75 mA, BAX 13 |
| CR638 | 152-0327-00 | | | 50 V, 75 mA, BAX 13 |
| CR639 | 152-0516-00 | | | Silicon, replaceable by 1N5297 |
| CR640 | 152-0327-00 | | | 50 V, 75 mA, BAX 13 |
| CR663 | 152-0327-00 | | | 50 V, 75 mA, BAX 13 |
| CR667 | 152-0327-00 | | | 50 V, 75 mA, BAX 13 |
| CR668 | 152-0327-00 | | | 50 V, 75 mA, BAX 13 |
| CR670 | 152-0327-00 | | | 50 V, 75 mA, BAX 13 |
| CR672 | 152-0327-00 | | | 50 V, 75 mA, BAX 13 |
| CR728 | 152-0327-00 | | | 50 V, 75 mA, BAX 13 |
| CR738 | 152-0327-00 | | | 50 V, 75 mA, BAX 13 |
| CR741 | 152-0327-00 | | | 50 V, 75 mA, BAX 13 |
| CR870 | 152-0107-00 | | | Silicon, replaceable by TI60 or 1N647 |
| CR880 | 152-0516-00 | | | Silicon, replaceable by 1N5297 |
| CR881 | 152-0327-00 | | | 50 V, 75 mA, BAX 13 |
| CR886A | 152-0327-00 | | | 50 V, 75 mA, BAX 13 |
| CR886B | 152-0327-00 | | | 50 V, 75 mA, BAX 13 |
| CR886C | 152-0327-00 | | | 50 V, 75 mA, BAX 13 |

ELECTRICAL PARTS LIST (cont)

| Ckt. No. | Tektronix Part No. | Serial/Model No. Eff | Disc | Description |
|---------------|--------------------|----------------------|------|---|
| DIODES (cont) | | | | |
| CR888 | 152-0516-00 | | | Silicon, replaceable by 1N5297 |
| CR890 | 152-0327-00 | | | 50 V, 75 mA, BAX 13 |
| CR892 | 152-0327-00 | | | 50 V, 75 mA, BAX 13 |
| CR894 | 152-0327-00 | | | 50 V, 75 mA, BAX 13 |
| CR896 | 152-0327-00 | | | 50 V, 75 mA, BAX 13 |
| CR922 | 152-0327-00 | | | 50 V, 75 mA, BAX 13 |
| CR929 | 152-0333-00 | | | Silicon, replaceable by FDH6012 |
| CR930 | 152-0327-00 | | | 50 V, 75 mA, BAX 13 |
| CR931 | 152-0333-00 | | | Silicon, replaceable by FDH6012 |
| CR932 | 152-0327-00 | | | 50 V, 75 mA, BAX 13 |
| CR933 | 152-0327-00 | | | 50 V, 75 mA, BAX 13 |
| CR934 | 152-0327-00 | | | 50 V, 75 mA, BAX 13 |
| CR940 | 152-0061-00 | | | Silicon, replaceable by CD8393 or FDH2161 |
| CR948 | 152-0327-00 | | | 50 V, 75 mA, BAX 13 |
| CR958 | 152-0327-00 | | | 50 V, 75 mA, BAX 13 |
| CR959 | 152-0522-00 | | | Silicon, replaceable by 1N1305 |
| CR960 | 152-0522-00 | | | Silicon, replaceable by 1N1305 |
| CR962 | 152-0327-00 | | | 50 V, 75 mA, BAX 13 |
| CR964 | 152-0327-00 | | | 50 V, 75 mA, BAX 13 |
| CR966 | 152-0327-00 | | | 50 V, 75 mA, BAX 13 |
| CR972 | 152-0327-00 | | | 50 V, 75 mA, BAX 13 |
| CR976 | 152-0061-00 | | | Silicon, replaceable by CD8393 or FDH2161 |
| CR990 | 152-0242-00 | | | Silicon, selected from 1N486A or replaceable by CD12691 |
| CR992 | 152-0061-00 | | | Silicon, replaceable by CD8393 or FDH2161 |
| CR994 | 152-0333-00 | | | Silicon, replaceable by FDH6012 |
| CR995 | 152-0516-00 | | | Silicon, replaceable by 1N5297 |
| CR1000 | 152-0522-00 | | | Silicon, replaceable by 1N1305 |
| CR1004 | 152-0327-00 | | | 50 V, 75 mA, BAX 13 |
| CR1015 | 152-0522-00 | | | Silicon, replaceable by 1N1305 |
| CR1026 | 152-0327-00 | | | 50 V, 75 mA, BAX 13 |
| CR1040A-G | 152-0331-00 | | | Rectifier, 1.5 kV, 25 mA, fast recovery |
| CR1105 | 152-0107-00 | | | Silicon, replaceable by TI60 or 1N647 |
| CR1110A,B,C,D | 152-0447-00 | | | Silicon, replaceable by 10D2 |
| CR1137 | 152-0008-00 | | | Germanium, replaceable by T12G |
| CR1138 | 152-0008-00 | | | Germanium, replaceable by T12G |
| VR95 | 152-0280-00 | | | Zener, replaceable by 1N753A 0.4 W, 6.2 V, 5% |
| VR692 | 152-0166-00 | | | Zener, selected from 1N753A, 0.4 W, 6.2 V, 5% |
| VR760 | 152-0127-00 | | | Zener, replaceable by 1N755A, 0.4 W, 7.5 V, 5% |
| VR882 | 152-0195-00 | | | Zener, selected from 1N751A, 0.4 W, 5.1 V, 5% |
| VR887 | 152-0166-00 | | | Zener, selected from 1N753A, 0.4 W, 6.2 V, 5% |
| VR898 | 152-0278-00 | | | Zener, replaceable by 1N4372A, 0.4 W, 3 V, 5% |
| VR941 | 152-0278-00 | | | Zener, replaceable by 1N4372A, 0.4 W, 3 V, 5% |
| VR973 | 152-0195-00 | | | Zener, selected from 1N751A, 0.4 W, 5.1 V, 5% |
| VR996 | 152-0166-00 | | | Zener, selected from 1N753A, 0.4 W, 6.2 V, 5% |
| VR997 | 152-0166-00 | | | Zener, selected from 1N753A, 0.4 W, 6.2 V, 5% |
| VR1051 | 152-0359-00 | | | Zener, 0.25 W, 9 V, 5% |
| VR1062 | 152-0281-00 | | | Zener, replaceable by 1N969B, 0.4 W, 22 V, 5% |
| VR1149 | 152-0166-00 | | | Zener, selected from 1N753A, 0.4 W, 6.2 V, 5% |
| BULB | | | | |
| DS878 | 150-0084-00 | | | Neon, 2 AA |

ELECTRICAL PARTS LIST (cont)

| Ckt. No. | Tektronix Part No. | Serial/Model No. Eff | No. Disc | Description |
|--------------------|--------------------|----------------------|----------|---|
| FUSES | | | | |
| F870 | 159-0098-00 | | | 1.6 A, fast-blo |
| F1101 | 159-0097-00 | | | 0.4 A, fast-blo |
| F1101 | 159-0100-00 | | | 0.2 A, fast-blo |
| INDUCTORS | | | | |
| L416 | 276-0543-00 | X300026 | | Core, ferrite |
| L426 | 276-0543-00 | X300026 | | Core, ferrite |
| L480 | 108-0587-00 | | | 5.6 mH |
| L612 | 108-0692-00 | | | 270 μ H |
| L860A | 108-0488-00 | | | 150 μ H |
| L860B | 108-0488-00 | | | 150 μ H |
| L870 | 108-0464-00 | | | 125 μ H |
| L943 | 108-0694-00 | | | 19 μ H |
| L990 | 108-0692-00 | | | 270 μ H |
| L994 | 108-0692-00 | | | 270 μ H |
| L1014 | 108-0463-00 | | | 35 μ H |
| L1032 | 108-0463-00 | | | 35 μ H |
| L1055A | 276-0638-00 | | | Core, ferrite |
| L1055B | 276-0638-00 | | | Core, ferrite |
| L1060 | 108-0671-00 | | | Trace rotation |
| TRANSISTORS | | | | |
| Q1 | 151-0190-02 | | | Silicon, NPN, replaceable by 2N3904 |
| Q9 | 151-0190-02 | | | Silicon, NPN, replaceable by 2N3904 |
| Q31A,B | 151-1010-00 | | | Silicon, FET, replaceable by SU-2115 or D/2N3822, dual |
| Q41A,B | 151-0232-00 | | | Silicon, NPN, replaceable by NS7348 or selected from 2N2919, dual |
| Q51 | 151-0221-02 | | | Silicon, PNP, replaceable by 2N4258 |
| Q52 | 151-0221-02 | | | Silicon, PNP, replaceable by 2N4258 |
| Q53 | 151-0190-02 | | | Silicon, NPN, replaceable by 2N3904 |
| Q55 | 151-0221-02 | | | Silicon, PNP, replaceable by 2N4258 |
| Q57 | 151-0221-02 | | | Silicon, PNP, replaceable by 2N4258 |
| Q59 | 151-0190-02 | | | Silicon, NPN, replaceable by 2N3904 |
| Q61 | 151-0190-02 | | | Silicon, NPN, replaceable by 2N3904 |
| Q71 | 151-0190-02 | | | Silicon, NPN, replaceable by 2N3904 |
| Q81 | 151-0221-02 | | | Silicon, PNP, replaceable by 2N4258 |
| Q89 | 151-0221-02 | | | Silicon, PNP, replaceable by 2N4258 |
| Q91 | 151-0190-02 | | | Silicon, NPN, replaceable by 2N3904 |
| Q95 | 151-0190-02 | | | Silicon, NPN, replaceable by 2N3904 |
| Q98 | 151-0190-02 | | | Silicon, NPN, replaceable by 2N3904 |
| Q99 | 151-0190-02 | | | Silicon, NPN, replaceable by 2N3904 |
| Q231A,B | 151-1010-00 | | | Silicon, FET, replaceable by SU-2115 or D/2N3822, dual |
| Q241A,B | 151-0232-00 | | | Silicon, NPN, replaceable by NS7348 or selected from 2N2919, dual |
| Q251 | 151-0221-02 | | | Silicon, PNP, replaceable by 2N4258 |
| Q252 | 151-0221-02 | | | Silicon, PNP, replaceable by 2N4258 |
| Q253 | 151-0190-02 | | | Silicon, NPN, replaceable by 2N3904 |
| Q255 | 151-0221-02 | | | Silicon, PNP, replaceable by 2N4258 |
| Q257 | 151-0221-02 | | | Silicon, PNP, replaceable by 2N4258 |
| Q259 | 151-0190-02 | | | Silicon, NPN, replaceable by 2N3904 |
| Q261 | 151-0190-02 | | | Silicon, NPN, replaceable by 2N3904 |
| Q271 | 151-0190-02 | | | Silicon, NPN, replaceable by 2N3904 |
| Q281 | 151-0221-02 | | | Silicon, PNP, replaceable by 2N4258 |
| Q289 | 151-0221-02 | | | Silicon, PNP, replaceable by 2N4258 |

ELECTRICAL PARTS LIST (cont)

| Ckt. No. | Tektronix Part No. | Serial/Model No. Eff | Disc | Description |
|--------------------|--------------------|----------------------|--------|---|
| TRANSISTORS (cont) | | | | |
| Q291 | 151-0190-02 | | | Silicon, NPN, replaceable by 2N3904 |
| Q299 | 151-0190-02 | | | Silicon, NPN, replaceable by 2N3904 |
| Q333 | 151-0220-00 | | | Silicon, PNP, replaceable by 2N4122 |
| Q343 | 151-0220-00 | | | Silicon, PNP, replaceable by 2N4122 |
| Q351 | 151-0190-02 | | | Silicon, NPN, replaceable by 2N3904 |
| Q355 | 151-0220-00 | | | Silicon, PNP, replaceable by 2N4122 |
| Q361 | 151-0190-02 | | | Silicon, NPN, replaceable by 2N3904 |
| Q376 | 151-0220-00 | | | Silicon, PNP, replaceable by 2N4122 |
| Q386 | 151-0220-00 | | | Silicon, PNP, replaceable by 2N4122 |
| Q392 | 151-0190-02 | | | Silicon, NPN, replaceable by 2N3904 |
| Q410 | 151-0190-02 | | | Silicon, NPN, replaceable by 2N3904 |
| Q415 | 151-0369-00 | | | Silicon, PNP, Tek Spec |
| Q416 | 151-0367-00 | | | Silicon, NPN, replaceable by SKA6516 |
| Q420 | 151-0190-02 | | | Silicon, NPN, replaceable by 2N3904 |
| Q425 | 151-0369-00 | | | Silicon, PNP, Tek Spec |
| Q426 | 151-0367-00 | | | Silicon, NPN, replaceable by SKA6516 |
| Q432 | 151-0375-00 | | | Silicon, NPN, replaceable by 2NC-403C |
| Q434 | 151-0375-00 | | | Silicon, NPN, replaceable by 2NC-403C |
| Q448 | 151-0375-00 | | | Silicon, NPN, replaceable by 2NC-403C |
| Q452 | 151-0219-00 | | | Silicon, PNP, replaceable by 2N4250 |
| Q454 | 151-0376-00 | | | Silicon, NPN, replaceable by 2NC-402C |
| Q457 | 151-0234-00 | | | Silicon, NPN, replaceable by 2SC805 |
| Q458 | 151-0234-00 | | | Silicon, NPN, replaceable by 2SC805 |
| Q462 | 151-0234-00 | | | Silicon, NPN, replaceable by 2SC805 |
| Q464 | 151-0214-00 | | | Silicon, PNP, replaceable by 2N3495 |
| Q472 | 151-0234-00 | | | Silicon, PNP, replaceable by 2SC805 |
| Q474 | 151-0214-00 | | | Silicon, PNP, replaceable by 2N3495 |
| Q505 | 151-0220-00 | | | Silicon, PNP, replaceable by 2N4122 |
| Q510 | 151-0190-02 | | | Silicon, NPN, replaceable by 2N3904 |
| Q545 | 151-1038-00 | 300000 | 300120 | Silicon, FET, |
| Q545 | 151-1018-00 | 300121 | | Silicon, FET, N channel, replaceable by 2SK-12R |
| Q552 | 151-0376-00 | | | Silicon, NPN, replaceable by 2SC-402C |
| Q556 | 151-0376-00 | | | Silicon, NPN, replaceable by 2SC-402C |
| Q570 | 151-0367-00 | | | Silicon, NPN, replaceable by SKA6516 |
| Q580 | 151-0367-00 | | | Silicon, NPN, replaceable by SKA6516 |
| Q611 | 151-0190-02 | | | Silicon, NPN, replaceable by 2N3904 |
| Q615 | 151-0190-02 | | | Silicon, NPN, replaceable by 2N3904 |
| Q630 | 151-0367-00 | | | Silicon, NPN, replaceable by SKA6516 |
| Q636 | 151-0367-00 | | | Silicon, NPN, replaceable by SKA6516 |
| Q638 | 151-0367-00 | | | Silicon, NPN, replaceable by SKA6516 |
| Q640 | 151-1018-00 | | | Silicon, FET, N channel, replaceable by 2SK-12R |
| Q652 | 151-0376-00 | | | Silicon, NPN, replaceable by 2SC-402C |
| Q655 | 151-0220-00 | | | Silicon, PNP, replaceable by 2N4122 |
| Q658 | 151-0190-02 | | | Silicon, NPN, replaceable by 2N3904 |
| Q661 | 151-0190-02 | | | Silicon, NPN, replaceable by 2N3904 |
| Q664 | 151-0190-02 | | | Silicon, NPN, replaceable by 2N3904 |
| Q672 | 151-0220-00 | | | Silicon, PNP, replaceable by 2N4122 |
| Q682 | 151-0234-00 | | | Silicon, NPN, replaceable by 2SC805 |
| Q685 | 151-0220-00 | | | Silicon, PNP, replaceable by 2N4122 |
| Q690 | 151-0234-00 | | | Silicon, NPN, replaceable by 2SC805 |
| Q692 | 151-0214-00 | | | Silicon, PNP, replaceable by 2N3495 |

ELECTRICAL PARTS LIST (cont)

| Ckt. No. | Tektronix Part No. | Serial/Model No. Eff | Disc | Description |
|--------------------|--------------------|----------------------|------|---|
| TRANSISTORS (cont) | | | | |
| Q726 | 151-0220-00 | | | Silicon, PNP, replaceable by 2N4122 |
| Q732 | 151-0190-02 | | | Silicon, NPN, replaceable by 2N3904 |
| Q738 | 151-0220-00 | | | Silicon, PNP, replaceable by 2N4122 |
| Q740 | 151-0220-00 | | | Silicon, PNP, replaceable by 2N4122 |
| Q741 | 151-0190-02 | | | Silicon, NPN, replaceable by 2N3904 |
| Q744 | 151-0376-00 | | | Silicon, NPN, replaceable by 2SC-402C |
| Q746 | 151-0376-00 | | | Silicon, NPN, replaceable by 2SC-402C |
| Q748 | 151-0233-00 | | | Silicon, NPN, 2SC805 |
| Q756 | 151-0220-00 | | | Silicon, PNP, replaceable by 2N4122 |
| Q758 | 151-0228-00 | | | Silicon, PNP, selected from 2N4888 |
| Q770 | 151-0220-00 | | | Silicon, PNP, replaceable by 2N4122 |
| Q772 | 151-0228-00 | | | Silicon, PNP, selected from 2N4888 |
| Q786 | 151-0220-00 | | | Silicon, PNP, replaceable by 2N4122 |
| Q788 | 151-0233-00 | | | Silicon, NPN, 2SC805 |
| Q878 | 151-0179-00 | | | Silicon, NPN, replaceable by 2N3877A |
| Q882 | 151-0306-00 | | | Silicon, NPN, selected from 2SC756 |
| Q884 | 151-0306-00 | | | Silicon, NPN, selected from 2SC756 |
| Q887 | 151-0190-02 | | | Silicon, NPN, replaceable by 2N3904 |
| Q888 | 151-0190-02 | | | Silicon, NPN, replaceable by 2N3904 |
| Q890 | 151-0190-02 | | | Silicon, NPN, replaceable by 2N3904 |
| Q892 | 151-0190-02 | | | Silicon, NPN, replaceable by 2N3904 |
| Q917 | 151-0220-00 | | | Silicon, PNP, replaceable by 2N4122 |
| Q918 | 151-0306-00 | | | Silicon, NPN, selected from 2SC756 |
| Q928 | 151-0306-00 | | | Silicon, NPN, selected from 2SC756 |
| Q930 | 151-0306-00 | | | Silicon, NPN, selected from 2SC756 |
| Q942 | 151-0516-00 | | | Silicon, unijunction, replaceable by D13T1 |
| Q948 | 151-0306-00 | | | Silicon, NPN, selected from 2SC756 |
| Q976 | 151-0231-00 | | | Silicon, NPN, replaceable by 2SC756-3 |
| Q978 | 151-0231-00 | | | Silicon, NPN, replaceable by 2SC756-3 |
| Q1008 | 151-0190-02 | | | Silicon, NPN, replaceable by 2N3904 |
| Q1010 | 151-0190-02 | | | Silicon, NPN, replaceable by 2N3904 |
| Q1012 | 151-0164-00 | | | Silicon, PNP, replaceable by 2N5447 or 2N3702 |
| Q1018 | 151-0220-00 | | | Silicon, PNP, replaceable by 2N4122 |
| Q1022 | 151-0190-02 | | | Silicon, NPN, replaceable by 2N3904 |
| Q1024 | 151-0207-00 | | | Silicon, NPN, replaceable by 2N3415 |
| Q1120 | 151-0219-00 | | | Silicon, PNP, replaceable by 2N4250 |
| Q1121 | 151-0224-00 | | | Silicon, NPN, replaceable by 2N3692 |
| Q1134 | 151-0219-00 | | | Silicon, PNP, replaceable by 2N4250 |
| Q1136 | 151-0219-00 | | | Silicon, PNP, replaceable by 2N4250 |
| RESISTORS | | | | |
| R1 | 315-0100-01 | | | 10 Ω , 1/4 W, 5% |
| R2 | 315-0100-01 | | | 10 Ω , 1/4 W, 5% |
| R3 | 315-0102-01 | | | 1 k Ω , 1/4 W, 5% |
| R4 | 315-0752-01 | | | 7.5 k Ω , 1/4 W, 5% |
| R6 | 315-0331-01 | | | 330 Ω , 1/4 W, 5% |
| R8 | 315-0103-02 | | | 10 k Ω , 1/4 W, 5% |
| R9 | 315-0822-01 | | | 8.2 k Ω , 1/4 W, 5% |
| R12 | 321-0316-30 | | | 19.1 k Ω , 1/8 W, 1% |
| R13 | 321-0318-30 | | | 20 k Ω , 1/8 W, 1% |
| R15 | 321-0336-30 | | | 30.9 k Ω , 1/8 W, 1% |
| R17 | 321-0753-31 | | | 9 k Ω , 1/8 W, 1/2% |
| R18 | 321-0754-31 | | | 900 Ω , 1/8 W, 1/2% |

ELECTRICAL PARTS LIST (cont)

| Ckt. No. | Tektronix Part No. | Serial/Model No. Eff | Disc | Description |
|------------------|--------------------|----------------------|------|-------------------------------|
| RESISTORS (cont) | | | | |
| R19 | 321-0636-00 | | | 100 Ω , 1/8 W, 1/2% |
| R20 | 315-0474-01 | | | 470 k Ω , 1/4 W, 5% |
| R21 | 315-0470-02 | | | 47 Ω , 1/4 W, 5% |
| R23B | 322-0621-31 | | | 900 k Ω , 1/4 W, 1/2% |
| R23C | 321-1389-31 | | | 111 k Ω , 1/8 W, 1/2% |
| R24B | 322-0624-01 | | | 990 k Ω , 1/4 W, 1/2% |
| R24C | 321-1289-31 | | | 10.1 k Ω , 1/8 W, 1/2% |
| R25B | 322-0625-01 | | | 995 k Ω , 1/4 W, 1/2% |
| R25C | 321-0613-31 | | | 5.03 k Ω , 1/8 W, 1/2% |
| R27B | 322-0610-31 | | | 500 k Ω , 1/4 W, 1/2% |
| R27C | 323-0481-01 | | | 1 M Ω , 1/4 W, 1/2% |
| R27D | 315-0333-01 | | | 33 k Ω , 1/4 W, 5% |
| R28B | 322-0620-31 | | | 800 k Ω , 1/4 W, 1/2% |
| R28C | 321-0618-31 | | | 250 k Ω , 1/8 W, 1/2% |
| R29 | 322-0481-01 | | | 1 M Ω , 1/4 W, 1/2% |
| R30 | 321-0385-31 | | | 100 k Ω , 1/8 W, 1% |
| R31 | 315-0201-01 | | | 200 Ω , 1/4 W, 5% |
| R32 | 321-0068-30 | | | 49.9 Ω , 1/8 W, 1% |
| R33 | 321-0249-30 | | | 3.83 k Ω , 1/8 W, 1% |
| R35 | 321-0249-30 | | | 3.83 k Ω , 1/8 W, 1% |
| R36 | 311-0622-00 | | | 100 Ω , Var |
| R37 | 311-0634-00 | | | 500 Ω , Var |
| R38 | 321-0213-30 | | | 1.62 k Ω , 1/8 W, 1% |
| R40 | 321-0210-30 | | | 1.5 k Ω , 1/8 W, 1% |
| R41 | 311-0643-00 | | | 50 Ω , Var |
| R42 | 321-0103-30 | | | 115 Ω , 1/8 W, 1% |
| R44 | 321-0213-30 | | | 1.62 k Ω , 1/8 W, 1% |
| R46 | 321-0265-30 | | | 5.62 k Ω , 1/8 W, 1% |
| R47 | 315-0101-01 | | | 100 Ω , 1/4 W, 5% |
| R48 | 321-0223-30 | | | 2.05 k Ω , 1/8 W, 1% |
| R50 | 321-0217-30 | | | 1.78 k Ω , 1/8 W, 1% |
| R51 | 315-0101-01 | | | 100 Ω , 1/4 W, 5% |
| R52 | 321-0265-30 | | | 5.62 k Ω , 1/8 W, 1% |
| R53 | 321-0181-30 | | | 750 Ω , 1/8 W, 1% |
| R54 | 321-0223-30 | | | 2.05 k Ω , 1/8 W, 1% |
| R55 | 315-0101-01 | | | 100 Ω , 1/4 W, 5% |
| R57 | 321-0277-30 | | | 7.5 k Ω , 1/8 W, 1% |
| R59 | 321-0277-30 | | | 7.5 k Ω , 1/8 W, 1% |
| R60 | 315-0101-01 | | | 100 Ω , 1/4 W, 5% |
| R61 | 321-0223-30 | | | 2.05 k Ω , 1/8 W, 1% |
| R63 | 321-0260-30 | | | 4.99 k Ω , 1/8 W, 1% |
| R64 | 321-0157-30 | | | 422 Ω , 1/8 W, 1% |
| R65 | 311-0605-00 | | | 200 Ω , Var |
| R66 | 311-1329-00 | | | 3 k Ω , Var |
| R68 | 321-0231-30 | | | 2.49 k Ω , 1/8 W, 1% |
| R69 | 311-0634-00 | | | 500 Ω , Var |
| R71 | 321-0231-30 | | | 2.49 k Ω , 1/8 W, 1% |
| R72 | 321-0260-30 | | | 4.99 k Ω , 1/8 W, 1% |
| R74 | 315-0243-01 | | | 24 k Ω , 1/4 W, 5% |
| R76 | 315-0243-01 | | | 24 k Ω , 1/4 W, 5% |

ELECTRICAL PARTS LIST (cont)

| Ckt. No. | Tektronix Part No. | Serial/Model No. Eff | Disc | Description |
|------------------|--------------------|----------------------|------|-------------------------------|
| RESISTORS (cont) | | | | |
| R77 | 321-0293-30 | | | 11 k Ω , 1/8 W, 1% |
| R79 | 321-0293-30 | | | 11 k Ω , 1/8 W, 1% |
| R81 | 321-0264-30 | | | 5.49 k Ω , 1/8 W, 1% |
| R82 | 311-0633-00 | | | 5 k Ω , Var |
| R84 | 311-0633-00 | | | 5 k Ω , Var |
| R85 | 321-0264-30 | | | 5.49 k Ω , 1/8 W, 1% |
| R87 | 315-0272-02 | | | 2.7 k Ω , 1/4 W, 5% |
| R88 | 321-0251-30 | | | 4.02 k Ω , 1/8 W, 1% |
| R90 | 321-0251-30 | | | 4.02 k Ω , 1/8 W, 1% |
| R91 | 315-0272-02 | | | 2.7 k Ω , 1/4 W, 5% |
| R93 | 321-0193-30 | | | 1 k Ω , 1/8 W, 1% |
| R94 | 315-0471-02 | | | 470 Ω , 1/4 W, 5% |
| R95 | 315-0272-02 | | | 2.7 k Ω , 1/4 W, 5% |
| R96 | 315-0751-03 | | | 750 Ω , 1/4 W, 5% |
| R97 | 315-0391-02 | | | 390 Ω , 1/4 W, 5% |
| R98 | 315-0203-01 | | | 20 k Ω , 1/4 W, 5% |
| R99 | 315-0471-02 | | | 470 Ω , 1/4 W, 5% |
| R100 | 321-0193-30 | | | 1 k Ω , 1/8 W, 1% |
| R102 | 315-0101-01 | | | 100 Ω , 1/4 W, 5% |
| R104 | 315-0101-01 | | | 100 Ω , 1/4 W, 5% |
| R201 | 315-0100-01 | | | 10 Ω , 1/4 W, 5% |
| R202 | 315-0100-01 | | | 10 Ω , 1/4 W, 5% |
| R220 | 315-0474-01 | | | 470 k Ω , 1/4 W, 5% |
| R221 | 315-0470-02 | | | 47 Ω , 1/4 W, 5% |
| R223B | 322-0621-31 | | | 900 k Ω , 1/4 W, 1/2% |
| R223C | 321-1389-31 | | | 111 k Ω , 1/8 W, 1/2% |
| R224B | 322-0624-01 | | | 990 k Ω , 1/4 W, 1/2% |
| R224C | 321-1289-31 | | | 10.1 k Ω , 1/8 W, 1/2% |
| R225B | 322-0625-01 | | | 995 k Ω , 1/4 W, 1/2% |
| R225C | 321-0613-31 | | | 5.03 k Ω , 1/8 W, 1/2% |
| R227B | 322-0610-31 | | | 500 k Ω , 1/4 W, 1/2% |
| R227C | 322-0481-01 | | | 1 M Ω , 1/4 W, 1/2% |
| R227D | 315-0333-01 | | | 33 k Ω , 1/4 W, 5% |
| R228B | 322-0620-31 | | | 800 k Ω , 1/4 W, 1/2% |
| R228C | 321-0618-31 | | | 250 k Ω , 1/8 W, 1/2% |
| R229 | 322-0481-01 | | | 1 M Ω , 1/4 W, 1/2% |
| R230 | 321-0385-31 | | | 100 k Ω , 1/8 W, 1% |
| R231 | 315-0201-01 | | | 200 Ω , 1/4 W, 5% |
| R232 | 321-0068-30 | | | 49.9 Ω , 1/8 W, 1% |
| R233 | 321-0249-30 | | | 3.83 k Ω , 1/8 W, 1% |
| R235 | 321-0249-30 | | | 3.83 k Ω , 1/8 W, 1% |
| R236 | 311-0622-00 | | | 100 Ω , Var |
| R237 | 311-0634-00 | | | 500 Ω , Var |
| R238 | 321-0213-30 | | | 1.62 k Ω , 1/8 W, 1% |
| R240 | 321-0210-30 | | | 1.5 k Ω , 1/8 W, 1% |
| R241 | 311-0643-00 | | | 50 Ω , Var |
| R242 | 321-0103-30 | | | 115 Ω , 1/8 W, 1% |
| R244 | 321-0213-30 | | | 1.62 k Ω , 1/8 W, 1% |
| R246 | 321-0265-30 | | | 5.62 k Ω , 1/8 W, 1% |
| R247 | 315-0101-01 | | | 100 Ω , 1/4 W, 5% |
| R248 | 321-0223-30 | | | 2.05 k Ω , 1/8 W, 1% |

ELECTRICAL PARTS LIST (cont)

| Ckt. No. | Tektronix Part No. | Serial/Model No. Eff | Disc | Description |
|------------------|--------------------|----------------------|------|-----------------------------|
| RESISTORS (cont) | | | | |
| R250 | 321-0217-30 | | | 1.78 k Ω , 1/8 W, 1% |
| R251 | 315-0101-01 | | | 100 Ω , 1/4 W, 5% |
| R252 | 321-0265-30 | | | 5.62 k Ω , 1/8 W, 1% |
| R253 | 321-0181-30 | | | 750 Ω , 1/8 W, 1% |
| R254 | 321-0223-30 | | | 2.05 k Ω , 1/8 W, 1% |
| R255 | 315-0101-01 | | | 100 Ω , 1/4 W, 5% |
| R257 | 321-0277-30 | | | 7.5 k Ω , 1/8 W, 1% |
| R259 | 321-0277-30 | | | 7.5 k Ω , 1/8 W, 1% |
| R260 | 315-0101-01 | | | 100 Ω , 1/4 W, 5% |
| R261 | 321-0223-30 | | | 2.05 k Ω , 1/8 W, 1% |
| R263 | 321-0260-30 | | | 4.99 k Ω , 1/8 W, 1% |
| R264 | 321-0157-30 | | | 422 Ω , 1/8 W, 1% |
| R265 | 311-0605-00 | | | 200 Ω , Var |
| R266 | 311-1329-00 | | | 3 k Ω , Var |
| R268 | 321-0231-30 | | | 2.49 k Ω , 1/8 W, 1% |
| R269 | 311-0634-00 | | | 500 Ω , Var |
| R271 | 321-0231-30 | | | 2.49 k Ω , 1/8 W, 1% |
| R272 | 321-0260-30 | | | 4.99 k Ω , 1/8 W, 1% |
| R274 | 315-0243-01 | | | 24 k Ω , 1/4 W, 5% |
| R276 | 315-0243-01 | | | 24 k Ω , 1/4 W, 5% |
| R277 | 321-0293-30 | | | 11 k Ω , 1/8 W, 1% |
| R279 | 321-0293-30 | | | 11 k Ω , 1/8 W, 1% |
| R281 | 321-0264-30 | | | 5.49 k Ω , 1/8 W, 1% |
| R282 | 311-0633-00 | | | 5 k Ω , Var |
| R284 | 311-0633-00 | | | 5 k Ω , Var |
| R285 | 321-0264-30 | | | 5.49 k Ω , 1/8 W, 1% |
| R287 | 315-0272-02 | | | 2.7 k Ω , 1/4 W, 5% |
| R288 | 321-0251-30 | | | 4.02 k Ω , 1/8 W, 1% |
| R290 | 321-0251-30 | | | 4.02 k Ω , 1/8 W, 1% |
| R291 | 315-0272-02 | | | 2.7 k Ω , 1/4 W, 5% |
| R293 | 321-0193-30 | | | 1 k Ω , 1/8 W, 1% |
| R300 | 321-0193-30 | | | 1 k Ω , 1/8 W, 1% |
| R302 | 315-0101-01 | | | 100 Ω , 1/4 W, 5% |
| R304 | 315-0101-01 | | | 100 Ω , 1/4 W, 5% |
| R330 | 315-0152-01 | | | 1.5 k Ω , 1/4 W, 5% |
| R331 | 315-0272-02 | | | 2.7 k Ω , 1/4 W, 5% |
| R332 | 315-0222-02 | | | 2.2 k Ω , 1/4 W, 5% |
| R333 | 315-0222-02 | | | 2.2 k Ω , 1/4 W, 5% |
| R334 | 315-0391-02 | | | 390 Ω , 1/4 W, 5% |
| R335 | 315-0511-01 | | | 510 Ω , 1/4 W, 5% |
| R340 | 315-0152-01 | | | 1.5 k Ω , 1/4 W, 5% |
| R341 | 315-0272-02 | | | 2.7 k Ω , 1/4 W, 5% |
| R342 | 315-0222-02 | | | 2.2 k Ω , 1/4 W, 5% |
| R343 | 315-0222-02 | | | 2.2 k Ω , 1/4 W, 5% |
| R344 | 315-0391-02 | | | 390 Ω , 1/4 W, 5% |
| R345 | 315-0511-01 | | | 510 Ω , 1/4 W, 5% |
| R350 | 315-0201-01 | | | 200 Ω , 1/4 W, 5% |
| R351 | 315-0222-02 | | | 2.2 k Ω , 1/4 W, 5% |
| R352 | 315-0102-01 | | | 1 k Ω , 1/4 W, 5% |
| R355 | 315-0101-01 | | | 100 Ω , 1/4 W, 5% |

ELECTRICAL PARTS LIST (cont)

| Ckt. No. | Tektronix Part No. | Serial/Model No. Eff | Disc | Description |
|------------------|--------------------|----------------------|--------|-----------------------------|
| RESISTORS (cont) | | | | |
| R360 | 315-0104-02 | | | 100 k Ω , 1/4 W, 5% |
| R361 | 315-0122-01 | | | 1.2 k Ω , 1/4 W, 5% |
| R362 | 315-0471-02 | | | 470 Ω , 1/4 W, 5% |
| R363 | 315-0473-01 | | | 47 k Ω , 1/4 W, 5% |
| R370 | 321-0230-30 | | | 2.43 k Ω , 1/8 W, 1% |
| R375 | 321-0213-30 | | | 1.62 k Ω , 1/8 W, 1% |
| R376 | 315-0361-02 | | | 360 Ω , 1/4 W, 5% |
| R377 | 321-0099-30 | | | 105 Ω , 1/8 W, 1% |
| R380 | 321-0230-30 | | | 2.43 k Ω , 1/8 W, 1% |
| R385 | 321-0213-30 | | | 1.62 k Ω , 1/8 W, 1% |
| R386 | 315-0361-02 | | | 360 Ω , 1/4 W, 5% |
| R388 | 321-0099-30 | | | 105 Ω , 1/8 W, 1% |
| R390 | 315-0182-02 | | | 1.8 k Ω , 1/4 W, 5% |
| R391 | 315-0621-01 | | | 620 Ω , 1/4 W, 5% |
| R392 | 315-0512-01 | | | 5.1 k Ω , 1/4 W, 5% |
| R395 | 315-0471-02 | | | 470 Ω , 1/4 W, 5% |
| R397 | 321-0167-30 | | | 536 Ω , 1/8 W, 1% |
| R400 | 321-0223-30 | | | 2.05 k Ω , 1/8 W, 1% |
| R402 | 321-0223-30 | | | 2.05 k Ω , 1/8 W, 1% |
| R410 | 321-0097-30 | | | 100 Ω , 1/8 W, 1% |
| R411 | 311-0635-00 | | | 1 k Ω , Var |
| R412 | 321-0233-30 | | | 2.61 k Ω , 1/8 W, 1% |
| R413 | 321-0334-30 | | | 29.4 k Ω , 1/8 W, 1% |
| R414 | 321-0269-30 | | | 6.19 k Ω , 1/8 W, 1% |
| R415 | 315-0102-01 | | | 1 k Ω , 1/4 W, 5% |
| R416A | 321-0261-30 | | | 5.11 k Ω , 1/8 W, 1% |
| R416B | 315-0240-01 | | | 24 Ω , 1/4 W, 5% |
| R417 | 321-0233-30 | | | 2.61 k Ω , 1/8 W, 1% |
| R418 | 311-0609-00 | | | 2 k Ω , Var |
| R419 | 315-0101-01 | 300000 | 300025 | 100 Ω , 1/4 W, 5% |
| R419 | 315-0100-01 | 300026 | | 10 Ω , 1/4 W, 5% |
| R420 | 321-0097-30 | | | 100 Ω , 1/8 W, 1% |
| R421 | 311-0635-00 | | | 1 k Ω , Var |
| R422 | 321-0233-30 | | | 2.61 k Ω , 1/8 W, 1% |
| R424 | 321-0269-30 | | | 6.19 k Ω , 1/8 W, 1% |
| R425 | 315-0102-01 | | | 1 k Ω , 1/4 W, 5% |
| R426A | 321-0261-30 | | | 5.11 k Ω , 1/8 W, 1% |
| R426B | 315-0240-01 | | | 24 Ω , 1/4 W, 5% |
| R427 | 321-0233-30 | | | 2.61 k Ω , 1/8 W, 1% |
| R428 | 311-0609-00 | | | 2 k Ω , Var |
| R429 | 315-0101-01 | 300000 | 300025 | 100 Ω , 1/4 W, 5% |
| R429 | 315-0100-01 | 300026 | | 10 Ω , 1/4 W, 5% |
| R430 | 311-0607-00 | | | 10 k Ω , Var |
| R432 | 315-0561-02 | | | 560 Ω , 1/4 W, 5% |
| R434 | 315-0561-02 | | | 560 Ω , 1/4 W, 5% |
| R436 | 321-0253-30 | | | 4.22 k Ω , 1/8 W, 1% |
| R438 | 321-0253-30 | | | 4.22 k Ω , 1/8 W, 1% |
| R440 | 315-0272-02 | | | 2.7 k Ω , 1/4 W, 5% |
| R442 | 315-0101-01 | | | 100 Ω , 1/4 W, 5% |
| R444 | 315-0113-01 | | | 11 k Ω , 1/4 W, 5% |
| R446 | 315-0202-01 | | | 2 k Ω , 1/4 W, 5% |
| R448 | 315-0390-02 | | | 39 Ω , 1/4 W, 5% |

ELECTRICAL PARTS LIST (cont)

| Ckt. No. | Tektronix Part No. | Serial/Model No. Eff | Disc | Description |
|------------------|--------------------|----------------------|--------|-----------------------------|
| RESISTORS (cont) | | | | |
| R449 | 315-0392-01 | | | 3.9 k Ω , 1/4 W, 5% |
| R450 | 315-0822-01 | | | 8.2 k Ω , 1/4 W, 5% |
| R452 | 315-0302-01 | | | 3 k Ω , 1/4 W, 5% |
| R454 | 321-0113-30 | | | 147 Ω , 1/8 W, 1% |
| R456 | 321-0233-30 | | | 2.61 k Ω , 1/8 W, 1% |
| R457 | 321-0113-30 | | | 147 Ω , 1/8 W, 1% |
| R458 | 321-0113-30 | | | 147 Ω , 1/8 W, 1% |
| R459A | 315-0101-01 | | | 100 Ω , 1/4 W, 5% |
| R459B | 315-0101-01 | | | 100 Ω , 1/4 W, 5% |
| R460 | 321-0401-30 | | | 147 k Ω , 1/8 W, 1% |
| R462 | 315-0621-01 | | | 620 Ω , 1/4 W, 5% |
| R464 | 315-0562-01 | | | 5.6 k Ω , 1/4 W, 5% |
| R470 | 321-0401-30 | | | 147 k Ω , 1/8 W, 1% |
| R472 | 315-0621-01 | | | 620 Ω , 1/4 W, 5% |
| R474 | 315-0562-01 | | | 5.6 k Ω , 1/4 W, 5% |
| R476 | 315-0100-01 | | | 10 Ω , 1/4 W, 5% |
| R478 | 315-0100-01 | | | 10 Ω , 1/4 W, 5% |
| R480 | 315-0101-01 | | | 100 Ω , 1/4 W, 5% |
| R502 | 315-0511-01 | | | 510 Ω , 1/4 W, 5% |
| R503 | 315-0511-01 | | | 510 Ω , 1/4 W, 5% |
| R504A | 315-0511-01 | | | 510 Ω , 1/4 W, 5% |
| R504B | 315-0512-01 | | | 5.1 k Ω , 1/4 W, 5% |
| R505 | 315-0821-02 | | | 820 Ω , 1/4 W, 5% |
| R506 | 315-0202-01 | | | 2 k Ω , 1/4 W, 5% |
| R507 | 315-0202-01 | | | 2 k Ω , 1/4 W, 5% |
| R508 | 315-0751-03 | | | 750 Ω , 1/4 W, 5% |
| R510 | 315-0101-01 | | | 100 Ω , 1/4 W, 5% |
| R511 | 315-0472-01 | | | 4.7 k Ω , 1/4 W, 5% |
| R540 | 322-0481-00 | | | 1 M Ω , 1/4 W, 1% |
| R542 | 315-0104-02 | | | 100 k Ω , 1/4 W, 5% |
| R545 | 315-0332-02 | | | 3.3 k Ω , 1/4 W, 5% |
| R546 | 311-0644-00 | | | 20 k Ω , Var |
| R550 | 315-0472-01 | | | 4.7 k Ω , 1/4 W, 5% |
| R552 | 321-0237-30 | | | 2.87 k Ω , 1/8 W, 1% |
| R553 | 315-0161-01 | | | 160 Ω , 1/4 W, 5% |
| R554 | 321-0229-30 | | | 2.37 k Ω , 1/8 W, 1% |
| R556 | 321-0237-30 | | | 2.87 k Ω , 1/8 W, 1% |
| R557 | 315-0161-01 | | | 160 Ω , 1/4 W, 5% |
| R558 | 315-0472-01 | | | 4.7 k Ω , 1/4 W, 5% |
| R564 | 321-0297-30 | | | 12.1 k Ω , 1/8 W, 1% |
| R566 | 321-0269-30 | | | 6.19 k Ω , 1/8 W, 1% |
| R568 | 321-0333-30 | | | 28.7 k Ω , 1/8 W, 1% |
| R570 | 321-0177-30 | | | 681 Ω , 1/8 W, 1% |
| R572 | 321-0297-30 | | | 12.1 k Ω , 1/8 W, 1% |
| R574 | 321-0257-30 | | | 4.64 k Ω , 1/8 W, 1% |
| R576 | 321-0285-30 | | | 9.09 k Ω , 1/8 W, 1% |
| R578 | 321-0217-30 | | | 1.78 k Ω , 1/8 W, 1% |
| R580 | 321-0193-30 | | | 1 k Ω , 1/8 W, 1% |
| R582 | 321-0297-30 | 300000 | 300120 | 12.1 k Ω , 1/8 W, 1% |
| R582 | 321-0289-30 | 300121 | | 10 k Ω , 1/8 W, 1% |
| R590 | 315-0100-01 | | | 10 Ω , 1/4 W, 5% |
| R595 | 315-0100-01 | | | 10 Ω , 1/4 W, 5% |

ELECTRICAL PARTS LIST (cont)

| Ckt. No. | Tektronix Part No. | Serial/Model No. Eff | Disc | Description |
|------------------|--------------------|----------------------|------|-------------------------------------|
| RESISTORS (cont) | | | | |
| R611 | 311-0609-00 | | | 2 k Ω , Var |
| R611A | 315-0103-02 | | | 10 k Ω , 1/4 W, 5% |
| R611B | 315-0222-02 | | | 2.2 k Ω , 1/4 W, 5% |
| R612 | 315-0332-02 | | | 3.3 k Ω , 1/4 W, 5% |
| R613 | 315-0104-02 | | | 100 k Ω , 1/4 W, 5% |
| R614 | 315-0512-01 | | | 5.1 k Ω , 1/4 W, 5% |
| R615 | 315-0333-01 | | | 33 k Ω , 1/4 W, 5% |
| R616 | 315-0104-02 | | | 100 k Ω , 1/4 W, 5% |
| R617 | 321-0277-30 | | | 7.5 k Ω , 1/8 W, 1% |
| R618 | 311-0633-00 | | | 5 Ω , Var |
| R619 | 321-0255-30 | | | 4.42 k Ω , 1/8 W, 1% |
| R620A | 309-0095-00 | | | 10 M Ω , 1/2 W, 1% |
| R620B | 309-0087-00 | | | 5 M Ω , 1/2 W, 1% |
| R620C | 322-0481-01 | | | 1 M Ω , 1/4 W, 1/2% |
| R620D | 322-0481-01 | | | 1 M Ω , 1/4 W, 1/2% |
| R620E | 322-0610-31 | | | 500 k Ω , 1/4 W, 1/2% |
| R620F | 321-0414-31 | | | 200 k Ω , 1/8 W, 1/2% |
| R620G | 321-0385-31 | | | 100 k Ω , 1/8 W, 1/2% |
| R620H | 321-0756-31 | | | 50 k Ω , 1/8 W, 1/2% |
| R622A,B | 311-1330-00 | | | 50 k Ω x 20 k Ω , Var |
| R624 | 315-0123-01 | | | 12 k Ω , 1/4 W, 5% |
| R626 | 315-0102-01 | | | 1 k Ω , 1/4 W, 5% |
| R628 | 321-0251-30 | | | 4.02 k Ω , 1/8 W, 1% |
| R630 | 321-0235-30 | | | 2.74 k Ω , 1/8 W, 1% |
| R632 | 321-0239-30 | | | 3.01 k Ω , 1/8 W, 1% |
| R634 | 321-0263-30 | | | 5.36 k Ω , 1/8 W, 1% |
| R635 | 315-0752-01 | | | 7.5 k Ω , 1/4 W, 5% |
| R636 | 321-0268-30 | | | 6.04 k Ω , 1/8 W, 1% |
| R637 | 315-0563-02 | | | 56 k Ω , 1/4 W, 5% |
| R638 | 315-0152-01 | | | 1.5 k Ω , 1/4 W, 5% |
| R639A | 315-0682-01 | | | 6.8 k Ω , 1/4 W, 5% |
| R640 | 315-0682-01 | | | 6.8 k Ω , 1/4 W, 5% |
| R642 | 315-0221-01 | | | 220 Ω , 1/4 W, 5% |
| R644 | 315-0153-02 | | | 15 k Ω , 1/4 W, 5% |
| R646 | 315-0563-02 | | | 56 k Ω , 1/4 W, 5% |
| R648 | 315-0511-01 | | | 510 Ω , 1/4 W, 5% |
| R650 | 315-0102-01 | | | 1 k Ω , 1/4 W, 5% |
| R652 | 315-0222-02 | | | 2.2 k Ω , 1/4 W, 5% |
| R653 | 315-0222-02 | | | 2.2 k Ω , 1/4 W, 5% |
| R655 | 315-0102-01 | | | 1 k Ω , 1/4 W, 5% |
| R656 | 315-0103-02 | | | 10 k Ω , 1/4 W, 5% |
| R658 | 315-0332-02 | | | 3.3 k Ω , 1/4 W, 5% |
| R660 | 315-0822-01 | | | 8.2 k Ω , 1/4 W, 5% |
| R661 | 316-0913-01 | | | 91 k Ω , 1/4 W, 5% |
| R663 | 315-0104-02 | | | 100 k Ω , 1/4 W, 5% |
| R664 | 315-0333-01 | | | 33 k Ω , 1/4 W, 5% |
| R665 | 315-0562-01 | | | 5.6 k Ω , 1/4 W, 5% |
| R666 | 315-0203-01 | | | 20 k Ω , 1/4 W, 5% |
| R667 | 315-0112-01 | | | 1.1 k Ω , 1/4 W, 5% |
| R669 | 315-0102-01 | | | 1 k Ω , 1/4 W, 5% |

ELECTRICAL PARTS LIST (cont)

| Ckt. No. | Tektronix Part No. | Serial/Model No. Eff | Disc | Description |
|------------------|--------------------|----------------------|------|--|
| RESISTORS (cont) | | | | |
| R672 | 315-0101-01 | | | 100 Ω , 1/4 W, 5% |
| R674 | 315-0201-01 | | | 200 Ω , 1/4 W, 5% |
| R676 | 315-0272-02 | | | 2.7 k Ω , 1/4 W, 5% |
| R678 | 315-0752-01 | | | 7.5 k Ω , 1/4 W, 5% |
| R680 | 315-0202-01 | | | 2 k Ω , 1/4 W, 5% |
| R682 | 315-0473-01 | | | 47 k Ω , 1/4 W, 5% |
| R684 | 315-0103-02 | | | 10 k Ω , 1/4 W, 5% |
| R685 | 315-0202-01 | | | 2 k Ω , 1/4 W, 5% |
| R686 | 315-0274-01 | | | 270 k Ω , 1/4 W, 5% |
| R687 | 315-0474-01 | | | 470 k Ω , 1/4 W, 5% |
| R690 | 315-0102-01 | | | 1 k Ω , 1/4 W, 5% |
| R692 | 315-0682-01 | | | 6.8 k Ω , 1/4 W, 5% |
| R694 | 315-0101-01 | | | 100 Ω , 1/4 W, 5% |
| R695 | 315-0100-01 | | | 10 Ω , 1/4 W, 5% |
| R696 | 315-0100-01 | | | 10 Ω , 1/4 W, 5% |
| R701 | 321-0270-30 | | | 6.34 k Ω , 1/8 W, 1% |
| R702 | 311-0607-00 | | | 10 k Ω , Var |
| R703 | 321-0306-30 | | | 15 k Ω , 1/8 W, 1% |
| R704 | 311-0644-00 | | | 20 k Ω , Var |
| R705 | 315-0272-02 | | | 2.7 k Ω , 1/4 W, 5% |
| R706 | 315-0681-02 | | | 680 Ω , 1/4 W, 5% |
| R709 | 315-0272-02 | | | 2.7 k Ω , 1/4 W, 5% |
| R710 | 321-0318-30 | | | 20 k Ω , 1/8 W, 1% |
| R711 | 315-0104-02 | | | 100 k Ω , 1/4 W, 5% |
| R712 | 321-0556-30 | | | 49.9 k Ω , (nominal value) selected |
| R713 | 311-0644-00 | | | 2 k Ω , Var |
| R714 | 315-0272-02 | | | 2.7 k Ω , 1/4 W, 5% |
| R715 | 321-0264-30 | | | 5.49 k Ω , 1/8 W, 1% |
| R716 | 321-0309-30 | | | 16.2 k Ω , 1/8 W, 1% |
| R717 | 311-0633-00 | | | 5 k Ω , Var |
| R718 | 321-0223-30 | | | 2.05 k Ω , 1/8 W, 1% |
| R722 | 321-0126-30 | | | 200 Ω , 1/8 W, 1% |
| R724 | 321-0223-30 | | | 2.05 k Ω , 1/8 W, 1% |
| R726 | 321-0268-30 | | | 6.04 k Ω , 1/8 W, 1% |
| R728 | 321-0103-30 | | | 115 Ω , 1/8 W, 1% |
| R730 | 315-0512-01 | | | 5.1 k Ω , 1/4 W, 5% |
| R732 | 321-0239-30 | | | 3.01 k Ω , 1/8 W, 1% |
| R734 | 321-0260-30 | | | 4.99 k Ω , 1/8 W, 1% |
| R736 | 321-0260-30 | | | 4.99 k Ω , 1/8 W, 1% |
| R738 | 321-0356-30 | | | 49.9 k Ω , 1/8 W, 1% |
| R740 | 321-0289-30 | | | 10 k Ω , 1/8 W, 1% |
| R741 | 321-0233-30 | | | 2.61 k Ω , 1/8 W, 1% |
| R742 | 321-0226-30 | | | 2.21 k Ω , 1/8 W, 1% |
| R743 | 321-0231-30 | | | 2.49 k Ω , 1/8 W, 1% |
| R744 | 315-0223-02 | | | 22 k Ω , 1/4 W, 5% |
| R745 | 315-0242-02 | | | 2.4 k Ω , 1/4 W, 5% |
| R746 | 315-0242-02 | | | 2.4 k Ω , 1/4 W, 5% |
| R748 | 315-0332-02 | | | 3.3 k Ω , 1/4 W, 5% |
| R750 | 322-0610-31 | | | 500 k Ω , 1/4 W, 1/2% |
| R752 | 315-0303-02 | | | 30 k Ω , 1/4 W, 5% |

ELECTRICAL PARTS LIST (cont)

| Ckt. No. | Tektronix Part No. | Serial/Model No. Eff | No. Disc | Description |
|------------------|--------------------|----------------------|----------|---|
| RESISTORS (cont) | | | | |
| R754 | 315-0304-01 | | | 300 k Ω , 1/4 W, 5% |
| R756 | 315-0201-01 | | | 200 Ω , 1/4 W, 5% |
| R758 | 315-0103-02 | | | 10 k Ω , 1/4 W, 5% |
| R760 | 315-0105-01 | | | 1 M Ω , 1/4 W, 5% |
| R762 | 315-0102-01 | | | 1 k Ω , 1/4 W, 5% |
| R764 | 315-0203-01 | | | 20 k Ω , 1/4 W, 5% |
| R766 | 315-0303-02 | | | 30 k Ω , 1/4 W, 5% |
| R768 | 315-0244-01 | | | 240 k Ω , 1/4 W, 5% |
| R770 | 315-0201-01 | | | 200 Ω , 1/4 W, 5% |
| R772 | 315-0103-02 | | | 10 k Ω , 1/4 W, 5% |
| R775 | 315-0101-01 | | | 100 Ω , 1/4 W, 5% |
| R780 | 315-0101-01 | | | 100 Ω , 1/4 W, 5% |
| R782 | 322-0481-00 | | | 1 M Ω , 1/4 W, 1% |
| R784 | 322-0481-00 | | | 1 M Ω , 1/4 W, 1% |
| R786 | 321-0333-30 | | | 28.7 k Ω , 1/8 W, 1% |
| R788 | 315-0153-02 | | | 15 k Ω , 1/4 W, 5% |
| R791 | 315-0100-01 | | | 10 Ω , 1/4 W, 5% |
| R792 | 315-0100-01 | | | 10 Ω , 1/4 W, 5% |
| R870 | 321-0300-30 | | | 13 k Ω , 1/8 W, 1% |
| R871 | 321-0280-30 | | | 8.06 k Ω , 1/8 W, 1% |
| R872 | 321-0372-30 | | | 73.2 k Ω , 1/8 W, 1% |
| R873 | 321-0339-30 | | | 33.2 k Ω , 1/8 W, 1% |
| R878 | 315-0105-01 | | | 1 M Ω , 1/4 W, 5% |
| R880 | 315-0470-02 | | | 47 Ω , 1/4 W, 5% |
| R882 | 315-0470-02 | | | 47 Ω , 1/4 W, 5% |
| R884 | 315-0100-01 | | | 10 Ω , 1/4 W, 5% |
| R887 | 315-0243-01 | | | 24 k Ω , 1/4 W, 5% |
| R888 | 315-0562-01 | | | 5.6 k Ω , 1/4 W, 5% |
| R890 | 315-0243-01 | | | 24 k Ω , 1/4 W, 5% |
| R892 | 315-0243-01 | | | 24 k Ω , 1/4 W, 5% |
| R894 | 315-0204-01 | | | 200 k Ω , 1/4 W, 5% |
| R896 | 315-0204-01 | | | 200 k Ω , 1/4 W, 5% |
| R898 | 315-0432-01 | | | 4.3 k Ω , 1/4 W, 5% |
| R905 | 321-0318-30 | | | 20 k Ω , 1/8 W, 1% |
| R906 | 315-0125-02 | | | 1.2 M Ω , 1/4 W, 5% |
| R907 | 311-0609-00 | | | 2 k Ω , Var |
| R909 | 321-0260-30 | | | 4.99 k Ω , 1/8 W, 1% |
| R910 | 315-0103-02 | | | 10 k Ω , 1/4 W, 5% |
| R915 | 315-0102-01 | | | 1 k Ω , 1/4 W, 5% |
| R917 | 315-0101-01 | | | 100 Ω , 1/4 W, 5% |
| R922 | 315-0272-02 | | | 2.7 k Ω , 1/4 W, 5% |
| R924 | 315-0204-01 | | | 200 k Ω , 1/4 W, 5% |
| R926 | 315-0682-01 | | | 6.8 k Ω , 1/4 W, 5% |
| R927 | 315-0302-01 | | | 3 k Ω , 1/4 W, 5% |
| R928 | 315-0103-02 | | | 10 k Ω , 1/4 W, 5% |
| R930 | 315-0562-01 | | | 5.6 k Ω , 1/4 W, 5% |
| R932 | 315-0621-01 | | | 620 Ω , 1/4 W, 5% |
| R940 | 308-0503-00 | | | 6.8 Ω , (nominal value) selected |
| R941 | 315-0393-01 | | | 39 k Ω , 1/4 W, 5% |
| R942 | 311-1294-00 | | | 10 Ω , Var |

ELECTRICAL PARTS LIST (cont)

| Ckt. No. | Tektronix Part No. | Serial/Model No. Eff | Disc | Description |
|------------------|--------------------|----------------------|--------|----------------------------------|
| RESISTORS (cont) | | | | |
| R943 | 315-0100-01 | | | 10 Ω, 1/4 W, 5% |
| R946 | 315-0103-02 | | | 10 kΩ, 1/4 W, 5% |
| R948 | 315-0221-01 | | | 220 Ω, 1/4 W, 5% |
| R962 | 315-0150-01 | | | 15 Ω, 1/4 W, 5% |
| R972 | 315-0103-02 | | | 10 kΩ, 1/4 W, 5% |
| R974 | 315-0102-01 | | | 1 kΩ, 1/4 W, 5% |
| R976 | 315-0100-01 | | | 10 Ω, 1/4 W, 5% |
| R1002 | 321-0378-30 | | | 84.5 kΩ, 1/8 W, 1% |
| R1004 | 311-0644-00 | | | 20 kΩ, Var |
| R1006 | 321-0308-30 | | | 15.8 kΩ, 1/8 W, 1% |
| R1008 | 321-0348-30 | | | 41.2 kΩ, 1/8 W, 1% |
| R1009 | 315-0474-01 | | | 470 kΩ, 1/4 W, 5% |
| R1010 | 315-0333-01 | | | 33 kΩ, 1/4 W, 5% |
| R1012 | 315-0182-02 | | | 1.8 kΩ, 1/4 W, 5% |
| R1018 | 315-0102-01 | | | 1 kΩ, 1/4 W, 5% |
| R1020 | 315-0472-01 | | | 4.7 kΩ, 1/4 W, 5% |
| R1022 | 315-0470-02 | | | 47 Ω, 1/4 W, 5% |
| R1024 | 315-0162-01 | | | 1.6 kΩ, 1/4 W, 5% |
| R1026 | 321-0334-30 | | | 29.4 kΩ, 1/8 W, 1% |
| R1028 | 321-0300-30 | | | 13 kΩ, 1/8 W, 1% |
| R1030 | 311-0633-00 | | | 5 Ω, Var |
| R1032 | 321-0331-30 | | | 27.4 kΩ, 1/8 W, 1% |
| R1040 | 301-0226-01 | | | 22 MΩ, 1/2 W, 5% |
| R1044 | 315-0155-01 | 300000 | 300065 | 1.5 MΩ, (nominal value) selected |
| R1044 | 315-0105-01 | 300066 | | 1 MΩ, (nominal value) selected |
| R1046 | 311-1293-00 | | | 1 MΩ, Var |
| R1048 | 301-0106-01 | | | 10 MΩ, 1/2 W, 5% |
| R1049 | 301-0475-01 | | | 4.7 MΩ, 1/2 W, 5% |
| R1051A | 315-0183-02 | | | 18 kΩ, 1/4 W, 5% |
| R1051B | 315-0392-01 | | | 3.9 kΩ, 1/4 W, 5% |
| R1052 | 301-0685-01 | | | 6.8 MΩ, 1/2 W, 5% |
| R1053 | 301-0475-01 | | | 4.7 MΩ, 1/2 W, 5% |
| R1054 | 301-0475-01 | | | 4.7 MΩ, 1/2 W, 5% |
| R1055 | 301-0475-01 | | | 4.7 MΩ, 1/2 W, 5% |
| R1056 | 315-0470-02 | | | 47 Ω, 1/4 W, 5% |
| R1057 | 315-0470-02 | | | 47 Ω, 1/4 W, 5% |
| R1058 | 315-0754-02 | | | 750 kΩ, 1/4 W, 5% |
| R1059 | 315-0204-01 | | | 200 kΩ, 1/4 W, 5% |
| R1060 | 311-0607-00 | | | 10 kΩ, Var |
| R1062 | 311-0660-00 | | | 200 kΩ, Var |
| R1064 | 315-0204-01 | | | 200 kΩ, 1/4 W, 5% |
| R1066 | 315-0244-01 | | | 240 kΩ, 1/4 W, 5% |
| R1068 | 311-0660-00 | | | 200 kΩ, Var |
| R1070 | 315-0393-01 | | | 39 kΩ, 1/4 W, 5% |
| R1105 | 315-0562-01 | | | 5.6 kΩ, 1/4 W, 5% |
| R1115 | 308-0463-00 | | | 0.3 Ω, 3 W, WW, 1% |
| R1118 | 315-0472-01 | | | 4.7 kΩ, 1/4 W, 5% |
| R1119 | 315-0100-01 | | | 10 Ω, 1/4 W, 5% |
| R1120 | 315-0102-01 | | | 1 kΩ, 1/4 W, 5% |
| R1123 | 315-0471-02 | | | 470 Ω, 1/4 W, 5% |
| R1130 | 315-0272-02 | | | 2.7 kΩ, 1/4 W, 5% |

ELECTRICAL PARTS LIST (cont)

| Ckt. No. | Tektronix Part No. | Serial/Model No. Eff | Disc | Description |
|--------------------|--------------------|----------------------|------|--|
| RESISTORS (cont) | | | | |
| | R1133 | 301-0185-01 | | 1.8 M Ω , 1/2 W, 5% |
| | R1135 | 315-0752-01 | | 7.5 k Ω , 1/4 W, 5% |
| | R1137 | 315-0102-01 | | 1 k Ω , 1/4 W, 5% |
| | R1138 | 315-0102-01 | | 1 k Ω , 1/4 W, 5% |
| | R1139 | 315-0152-01 | | 1.5 k Ω , 1/4 W, 5% |
| | R1141 | 315-0272-02 | | 2.7 k Ω , 1/4 W, 5% |
| | R1143 | 321-0341-30 | | 34.8 k Ω , 1/8 W, 1% |
| | R1144 | 311-0635-00 | | 1 k Ω , Var |
| SWITCHES | | | | |
| | S20 ¹ | 670-1829-00 | | Pushbutton, AC-GND-DC (INPUT COUPLING CH1) |
| | S30 | 105-0302-00 | | Actuator assembly, VOLTS/DIV CH1 |
| | S220 ¹ | 670-1830-00 | | Pushbutton, AC-GND-DC (INPUT COUPLING CH2) |
| | S230 | 105-0302-00 | | Actuator assembly, VOLTS/DIV CH2 |
| | S302 ¹ | 260-1132-00 | | Push, INVERT CH2 |
| | S500 ¹ | 670-1827-00 | | Pushbutton, TRIG SOURCE |
| | S540 ¹ | 670-1828-00 | | Pushbutton, TRIG SOURCE/COUPLING |
| | S620 | 105-0301-00 | | Actuator assembly, TIME/DIV |
| TRANSFORMERS | | | | |
| | T410 | 120-0764-00 | | Toroid |
| | T930 | 120-0760-00 | | Blocking |
| | T970 | 120-0759-00 | | Fly-back |
| | T980 | 120-0758-00 | | Current sensing |
| | T1101 | 120-0757-00 | | Power |
| INTEGRATED CIRCUIT | | | | |
| | U910 | 156-0053-00 | | Voltage regulator, replaceable by UA723C |

¹See Mechanical Parts List for replacement parts.

SECTION 7

DIAGRAMS AND CIRCUIT BOARD ILLUSTRATIONS

Symbols and Reference Designators

Electrical components shown on the diagrams are in the following units unless noted otherwise:

- Capacitors = Values one or greater are in picofarads (pF).
 Values less than one are in microfarads (μ F).
 Resistors = Ohms (Ω)

Symbols used on the diagrams are based on USA Standard Y32.2-1967.

Logic symbology is based on MIL-STD-806B in terms of positive logic. Logic symbols depict the logic function performed and may differ from the manufacturer's data.

The following special symbols are used on the diagrams:

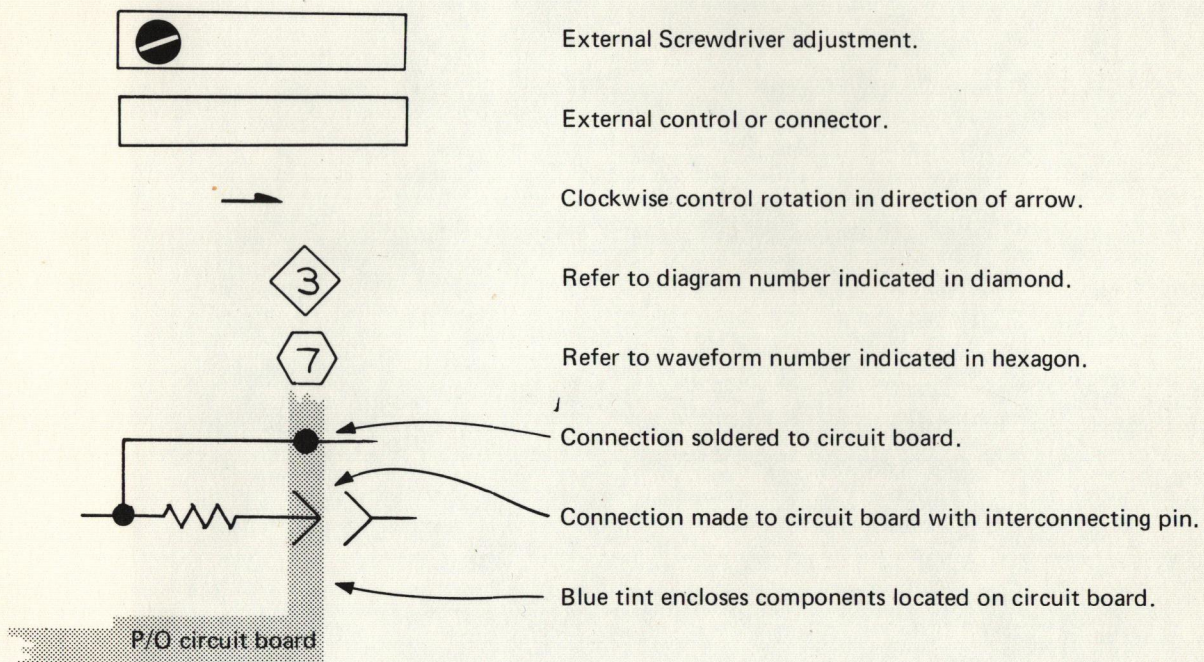

The following prefix letters are used as reference designators to identify components or assemblies on the diagrams.

| | | | |
|----|--|----|--|
| A | Assembly, separable or repairable (circuit board, etc.) | LR | Inductor/resistor combination |
| AT | Attenuator, fixed or variable | M | Meter |
| B | Motor | Q | Transistor or silicon-controlled rectifier |
| BT | Battery | P | Connector, movable portion |
| C | Capacitor, fixed or variable | R | Resistor, fixed or variable |
| CR | Diode, signal or rectifier | RT | Thermistor |
| DL | Delay line | S | Switch |
| DS | Indicating device (lamp) | T | Transformer |
| F | Fuse | TP | Test point |
| FL | Filter | U | Assembly, inseparable or non-repairable (integrated circuit, etc.) |
| H | Heat dissipating device (heat sink, heat radiator, etc.) | V | Electron tube |
| HR | Heater | VR | Voltage regulator (zener diode, etc.) |
| J | Connector, stationary portion | Y | Crystal |
| K | Relay | | |
| L | Inductor, fixed or variable | | |

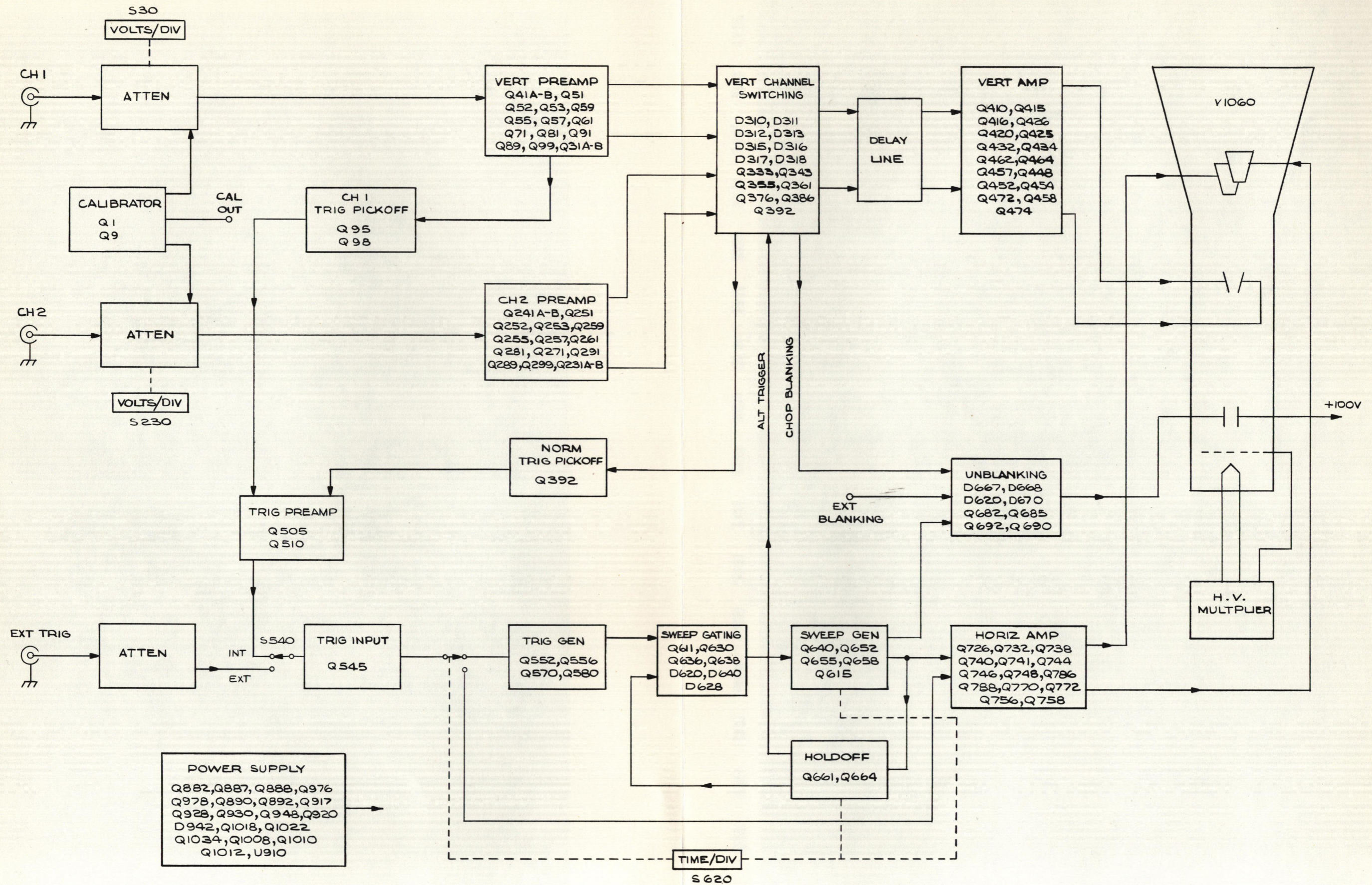

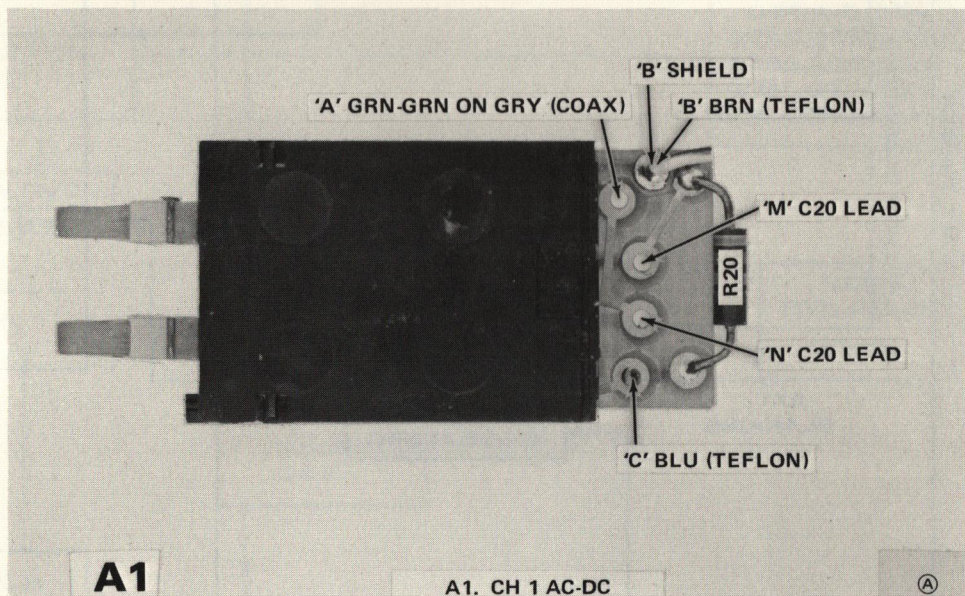

A4

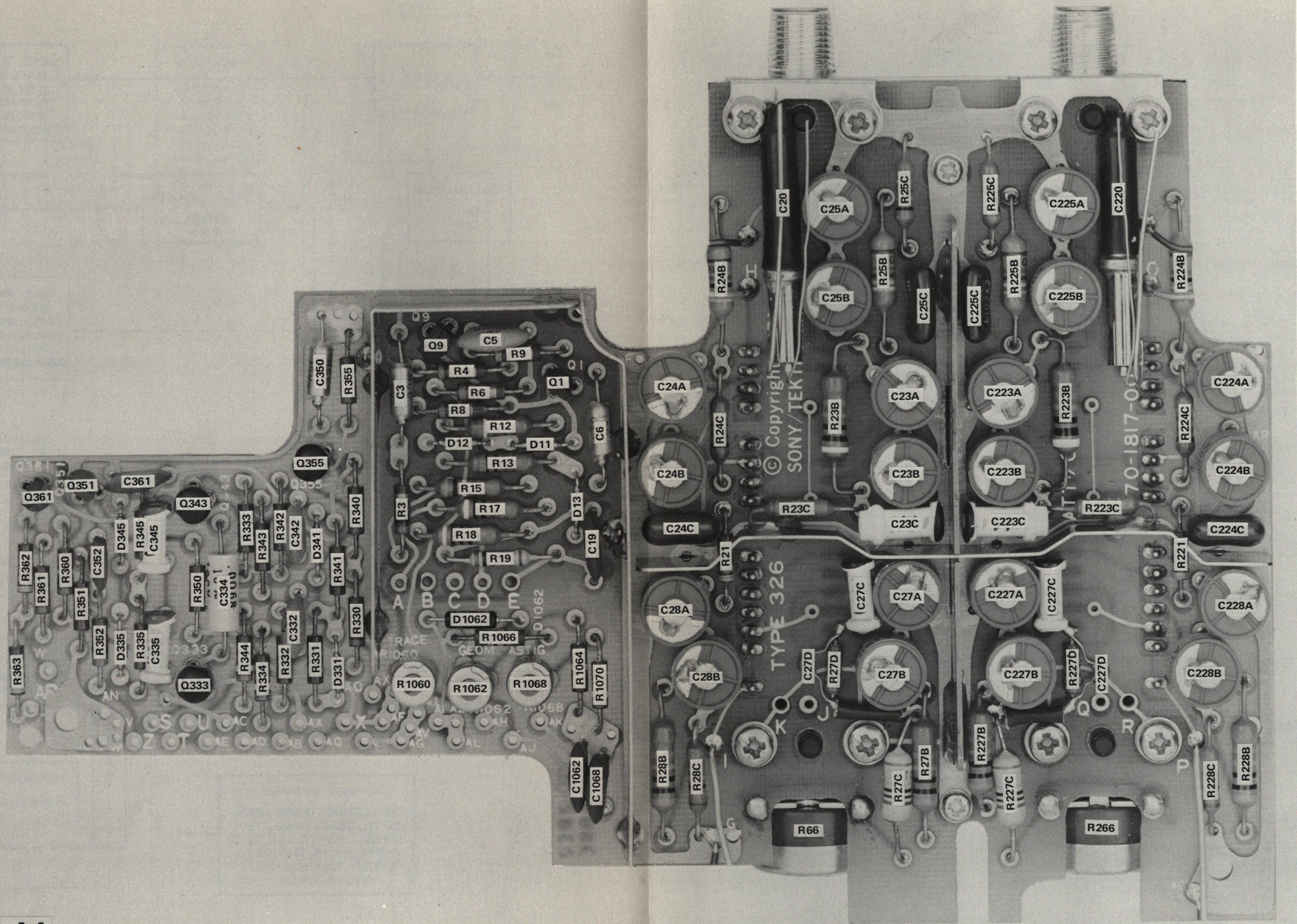

A4. Att-Cal-Switching

A

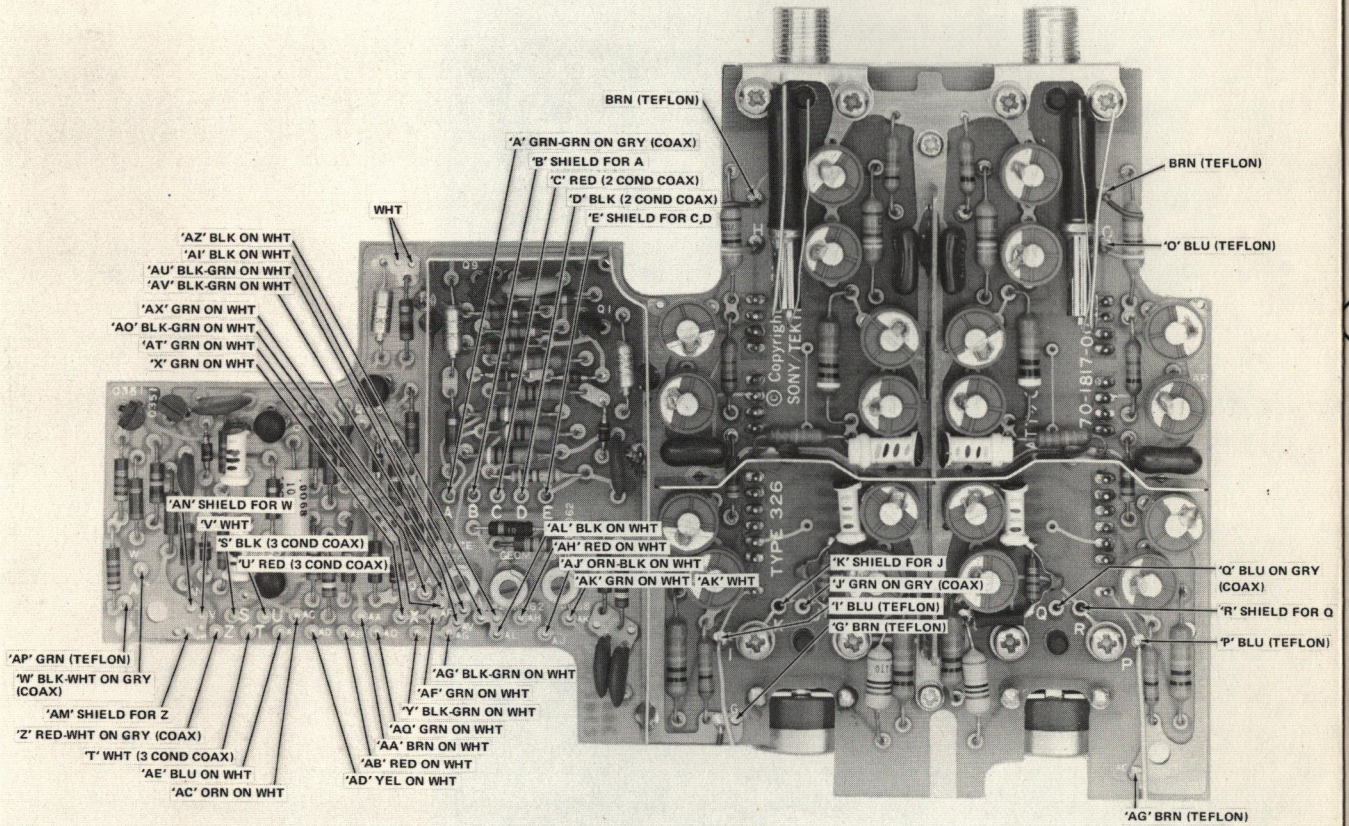

A4

A4. Att-Cal-Switching

ⓐ

S30

CH 1 VOLTS/DIV SWITCH SHOWN IN .01 VOLT/DIV POSITION

+

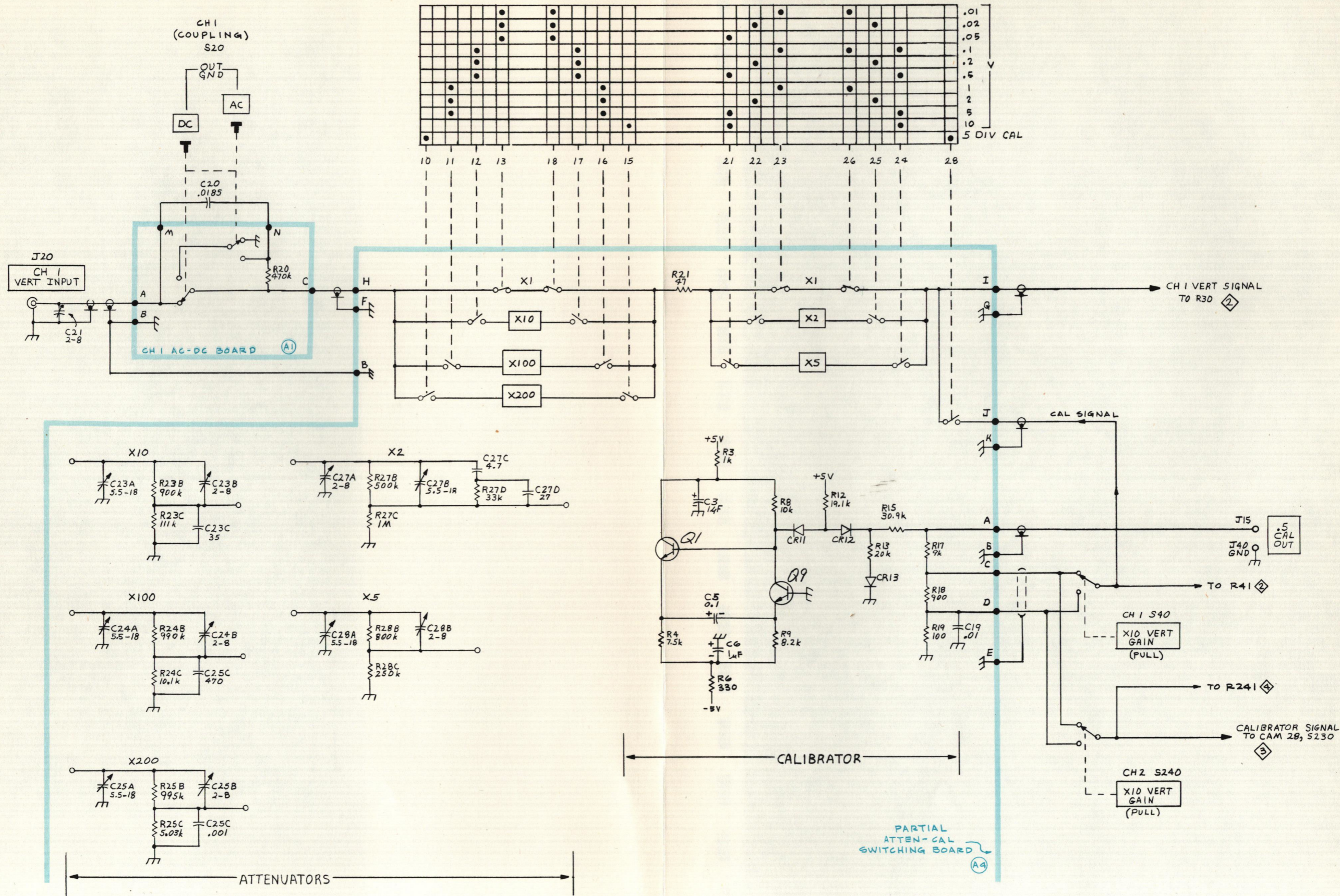

CH 1 ATTEN & CALIB 1

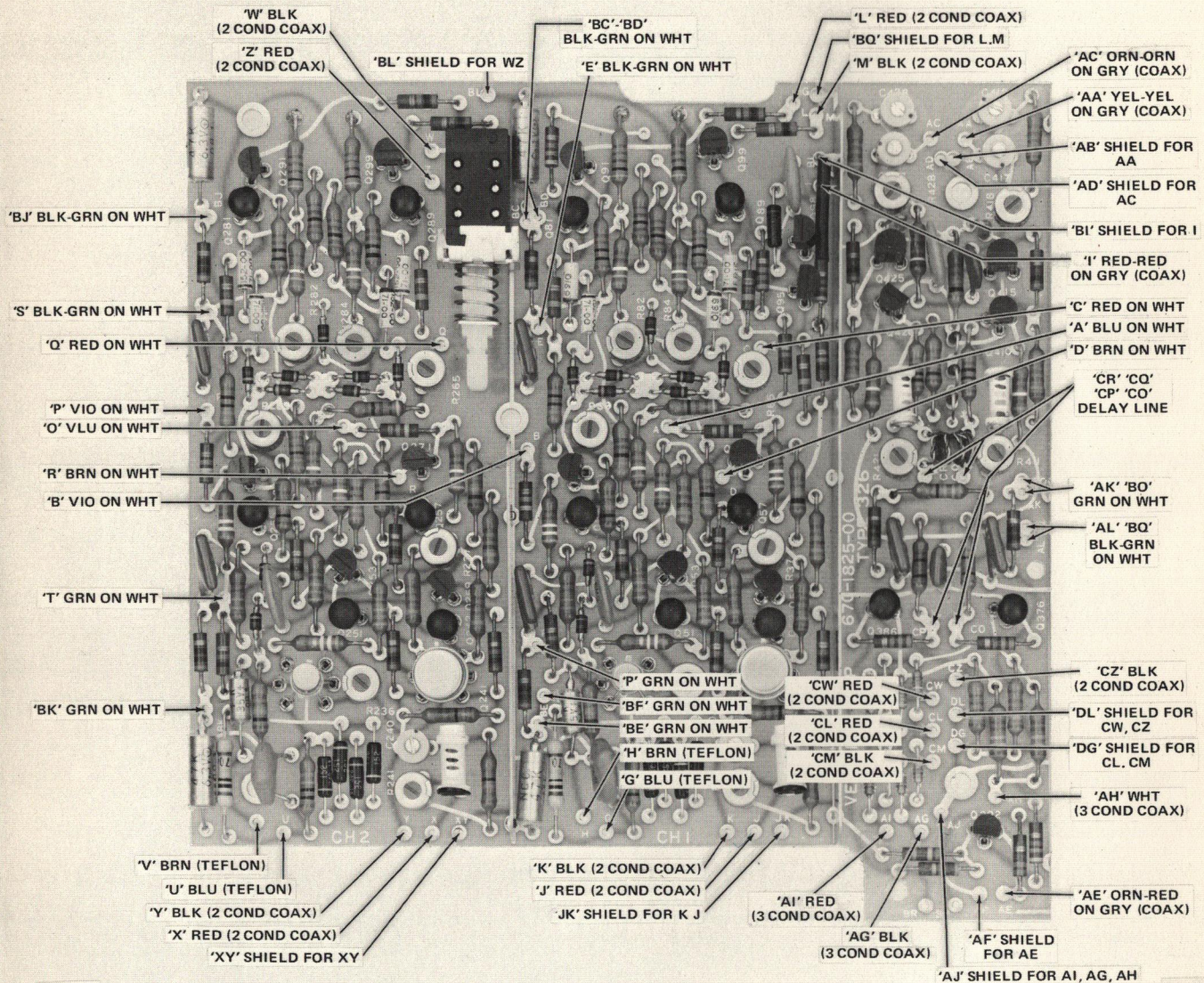

A3

A3. Vertical Preamp

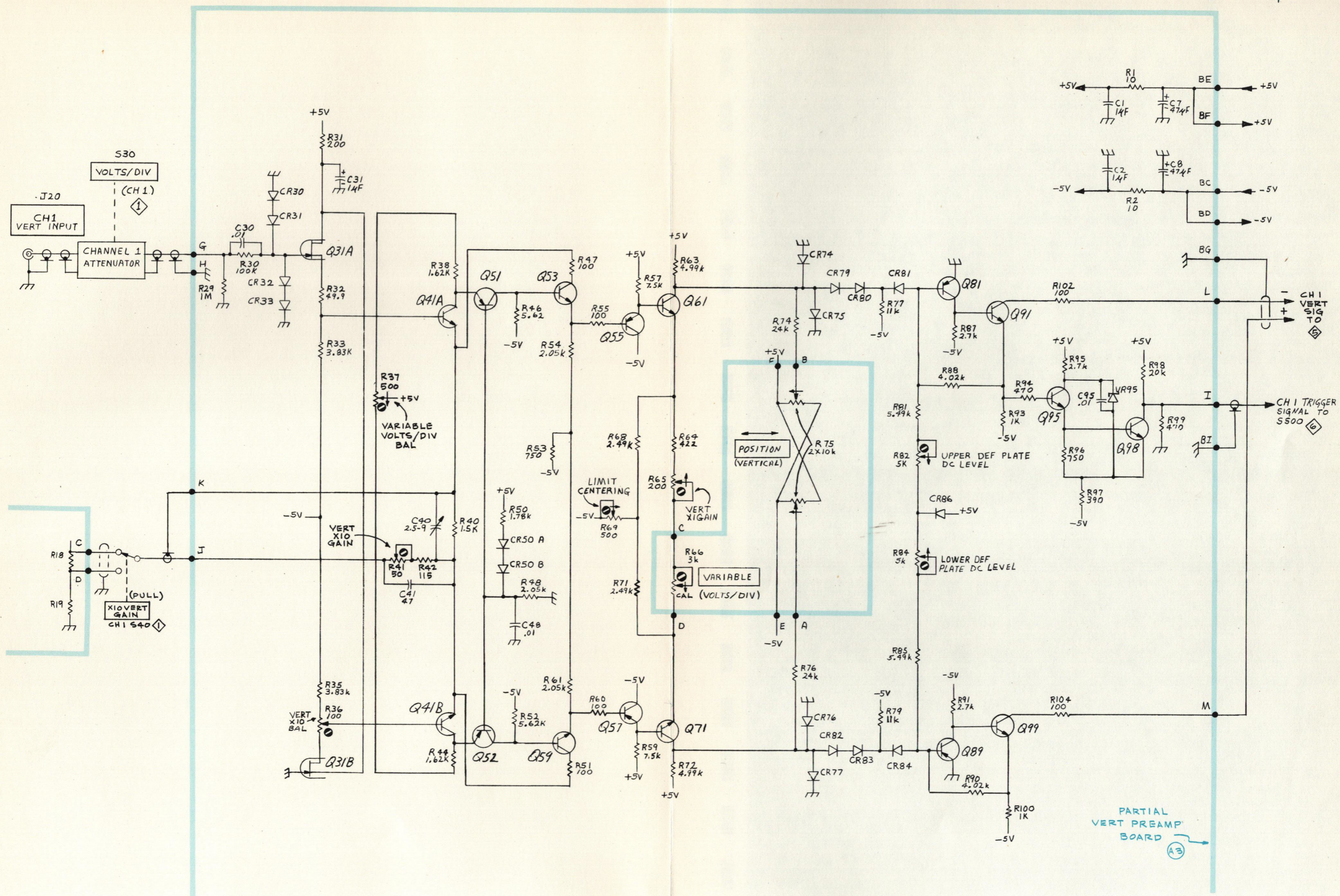

326 OSCILLOSCOPE

A

CHANNEL 1 VERTICAL PRE AMP 2

2/11/72
DAJ

PARTIAL
VERT PREAMP
BOARD 3

CH 1 VERT PREAMP

2

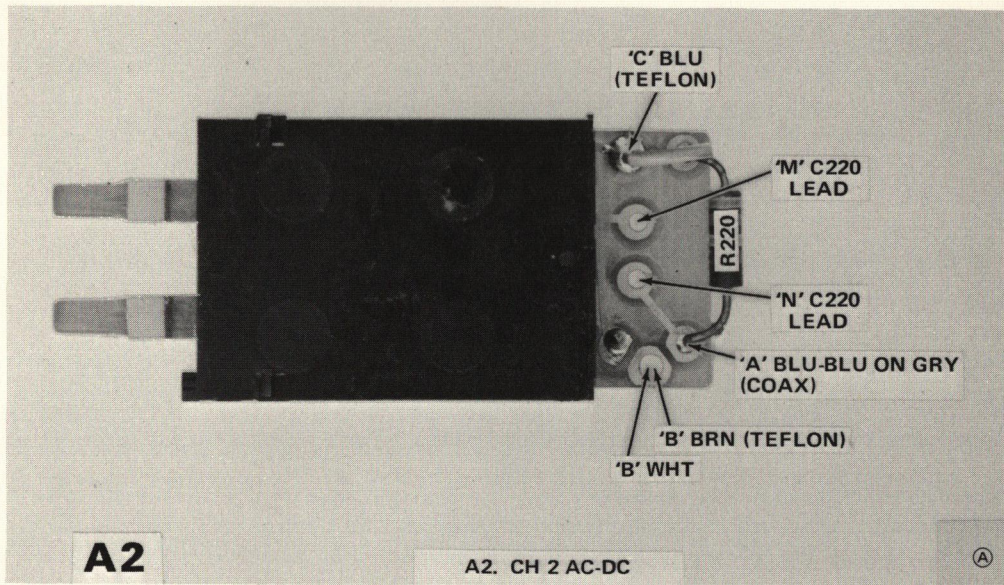

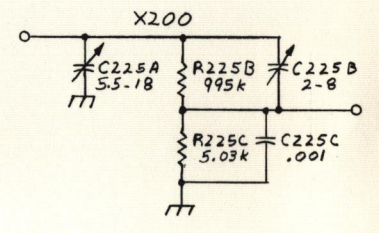
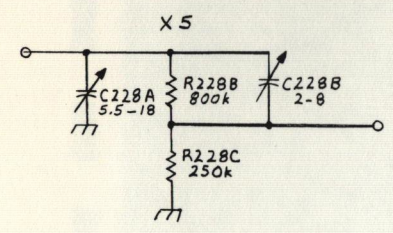
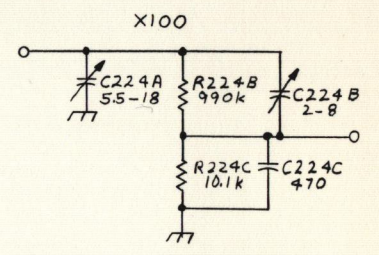
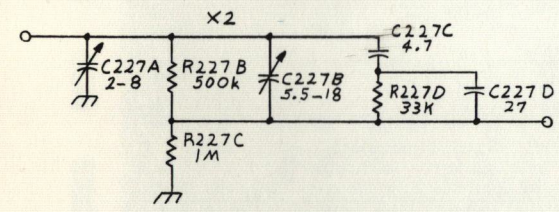
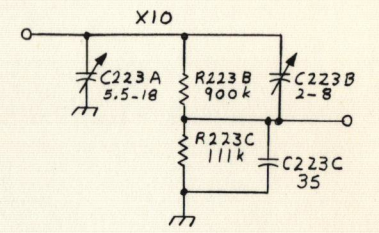
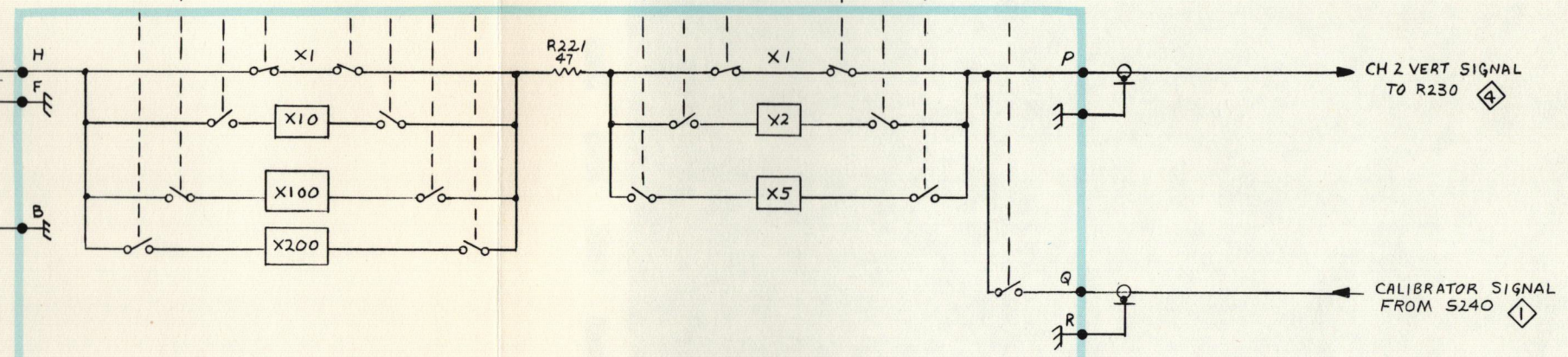
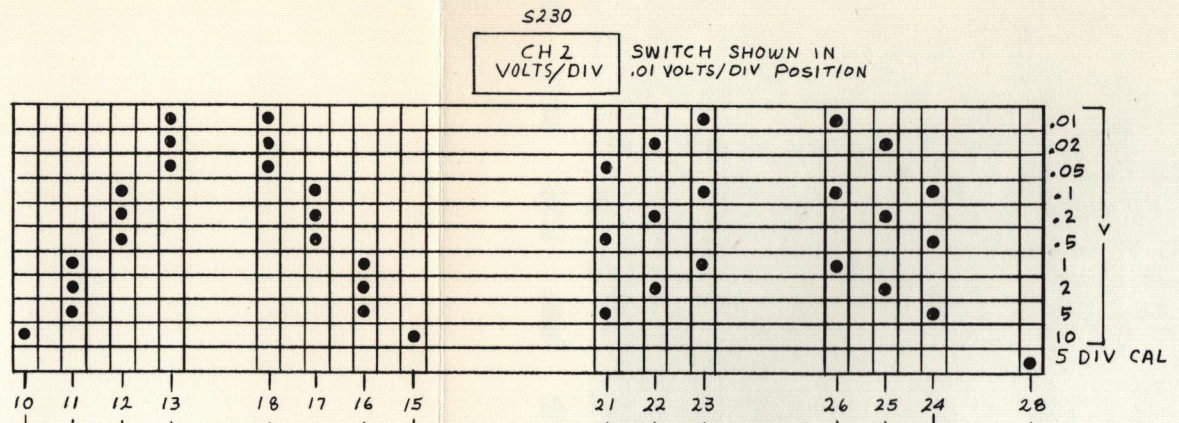
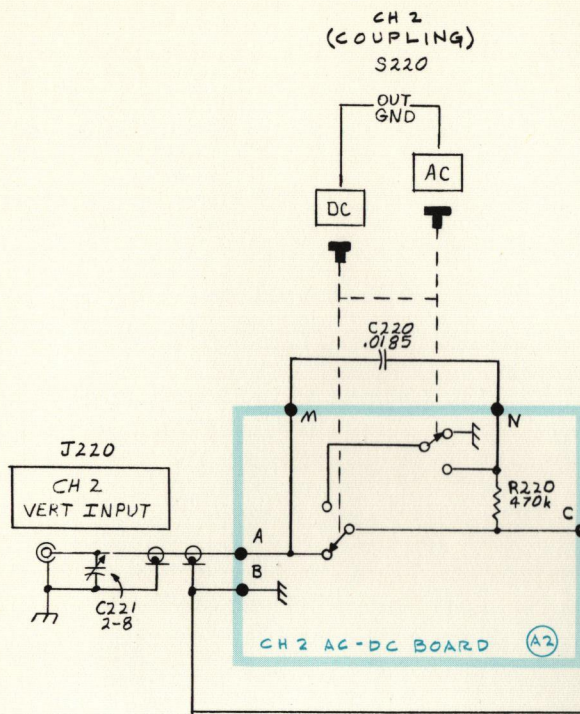

PARTIAL ATTEN-CAL-SWITCHING BOARD (A4)

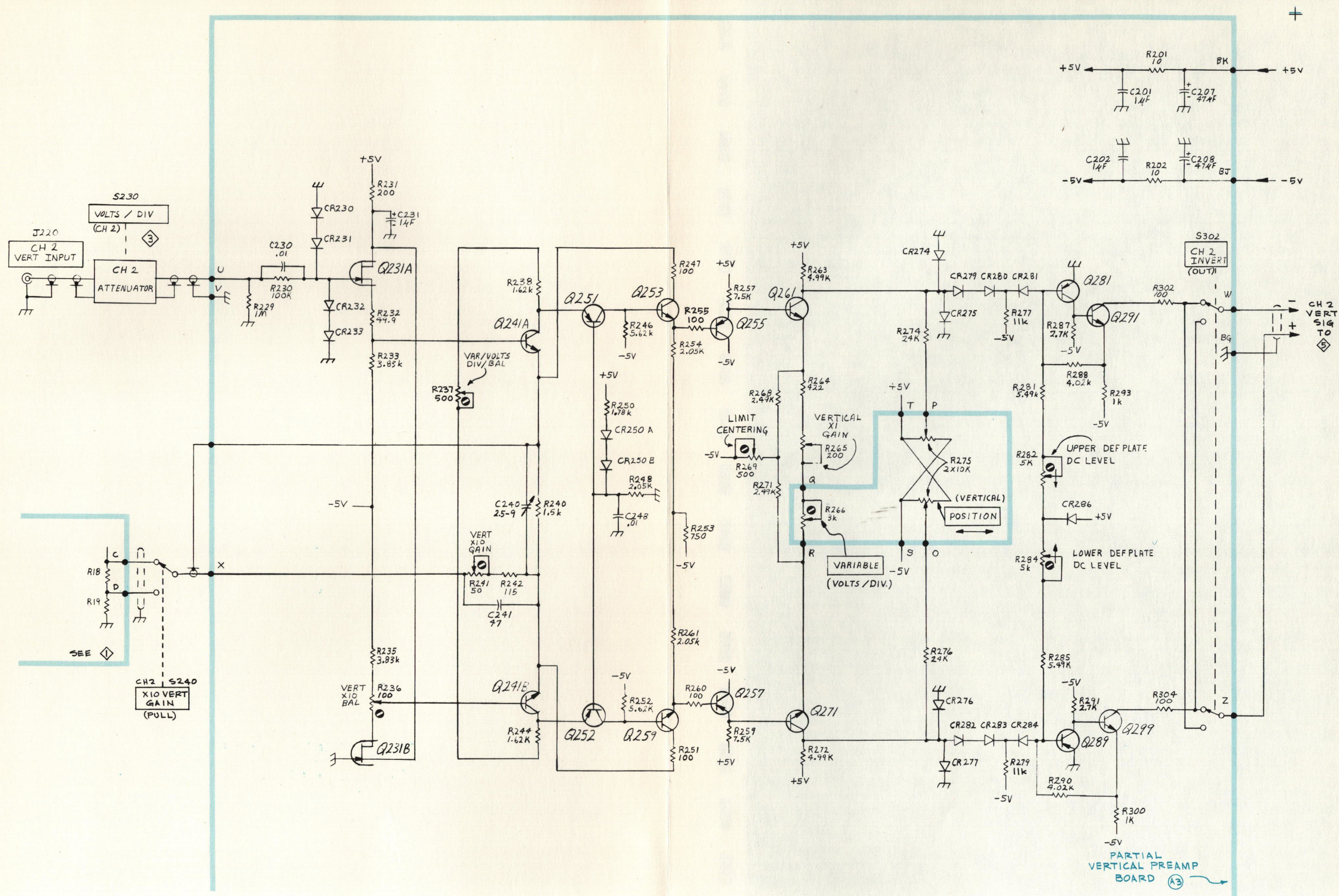

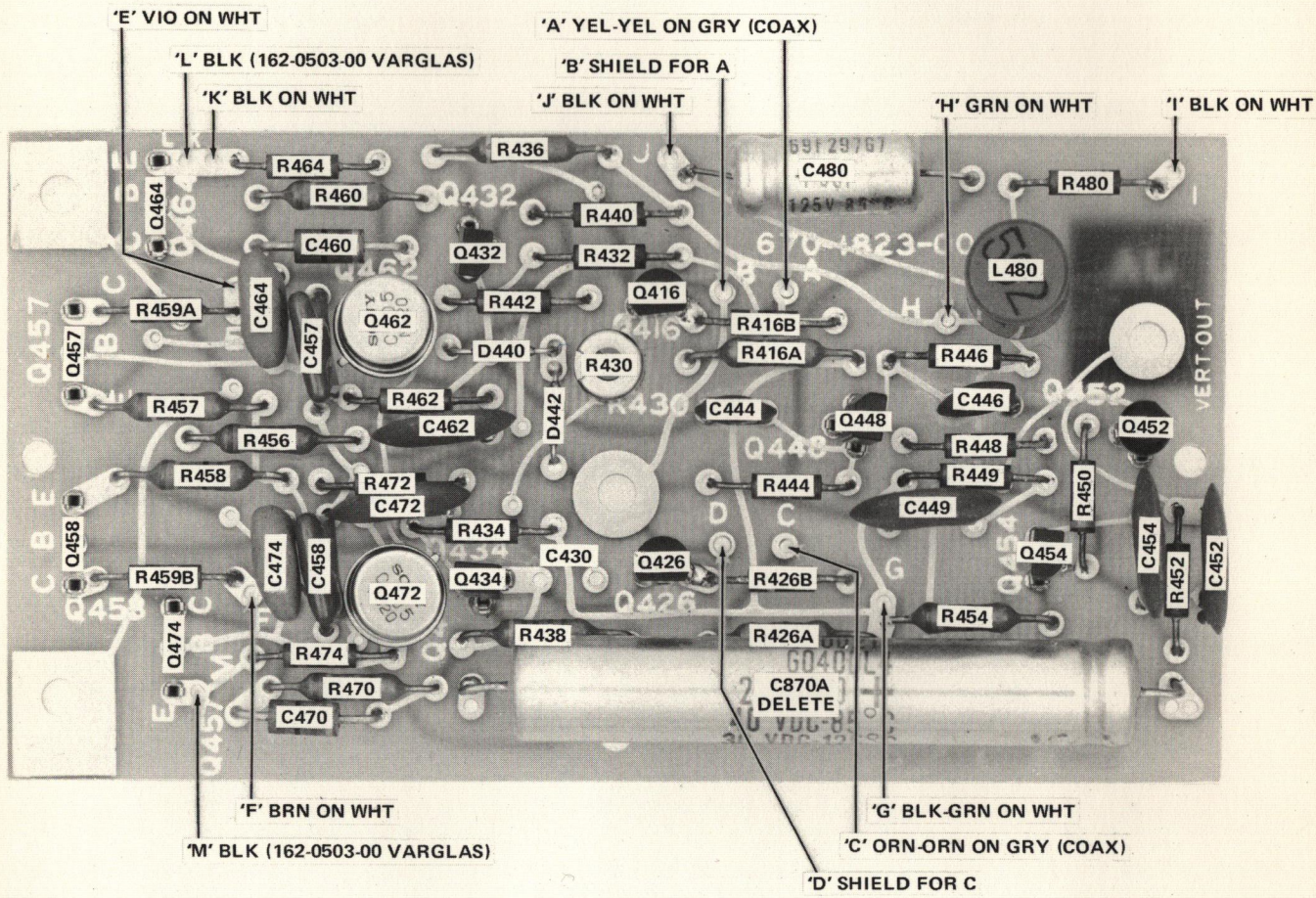

A5

A5. Vertical Output

(A)

VERT SWITCH &

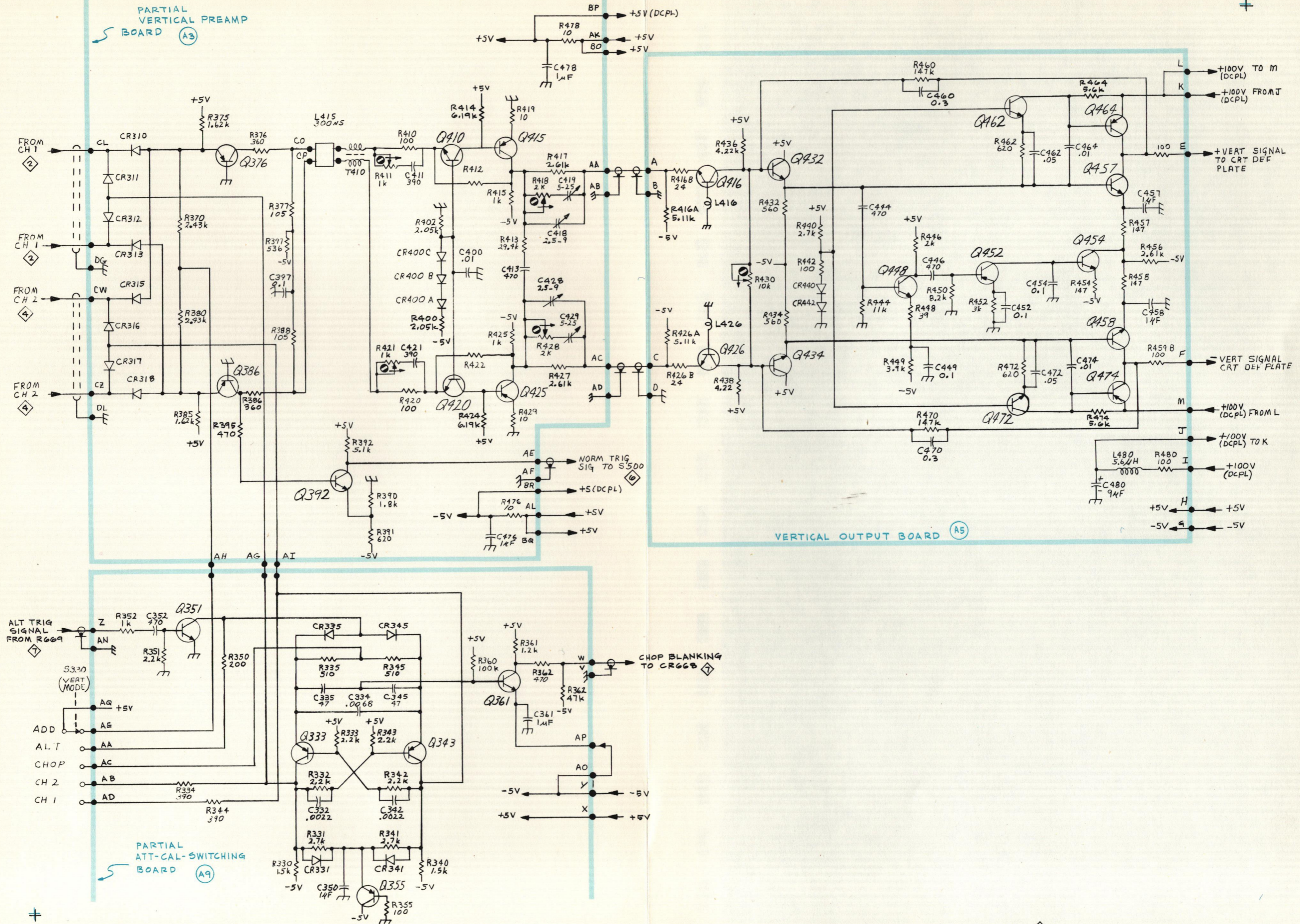

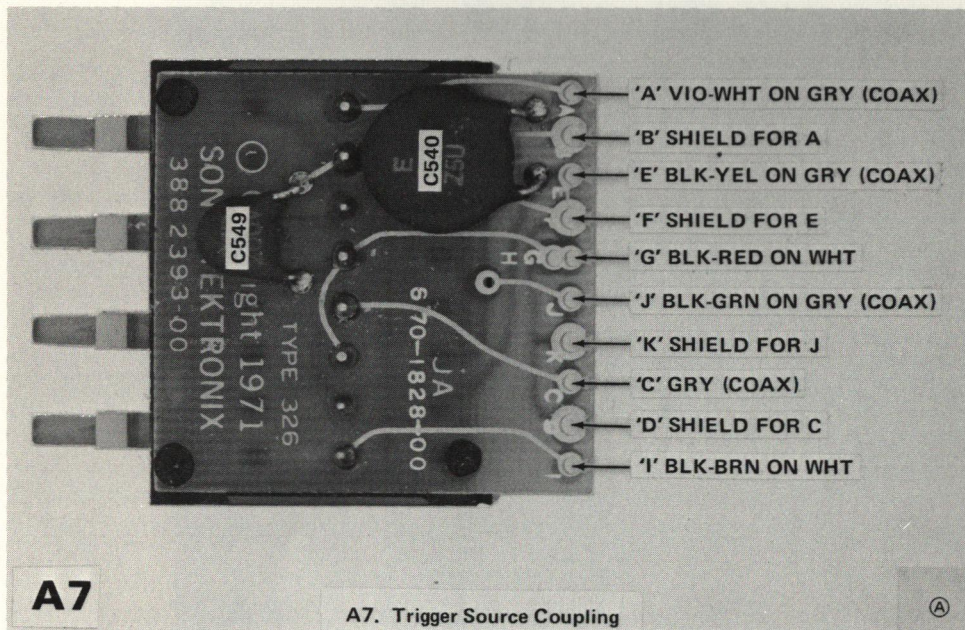
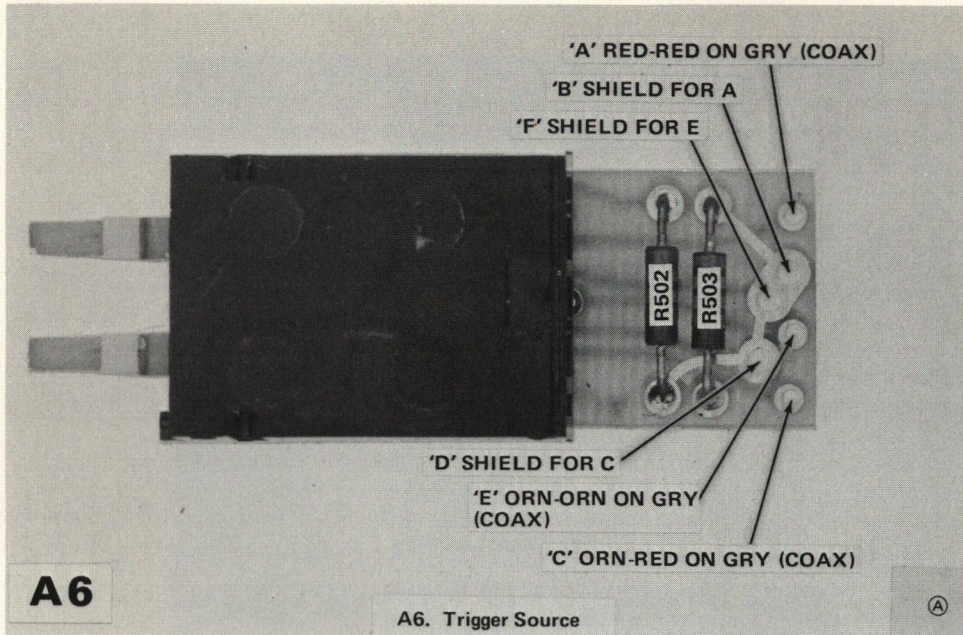

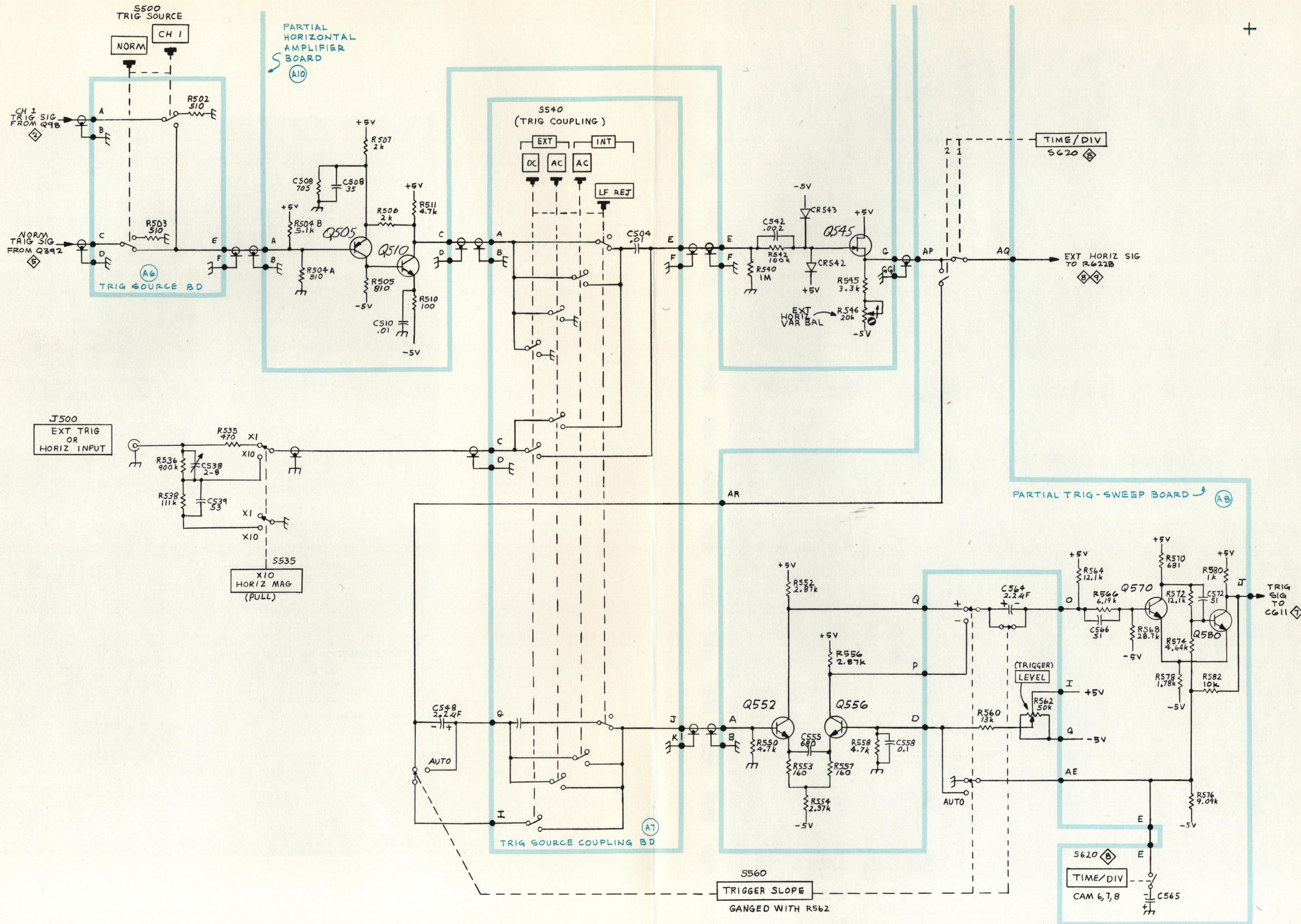

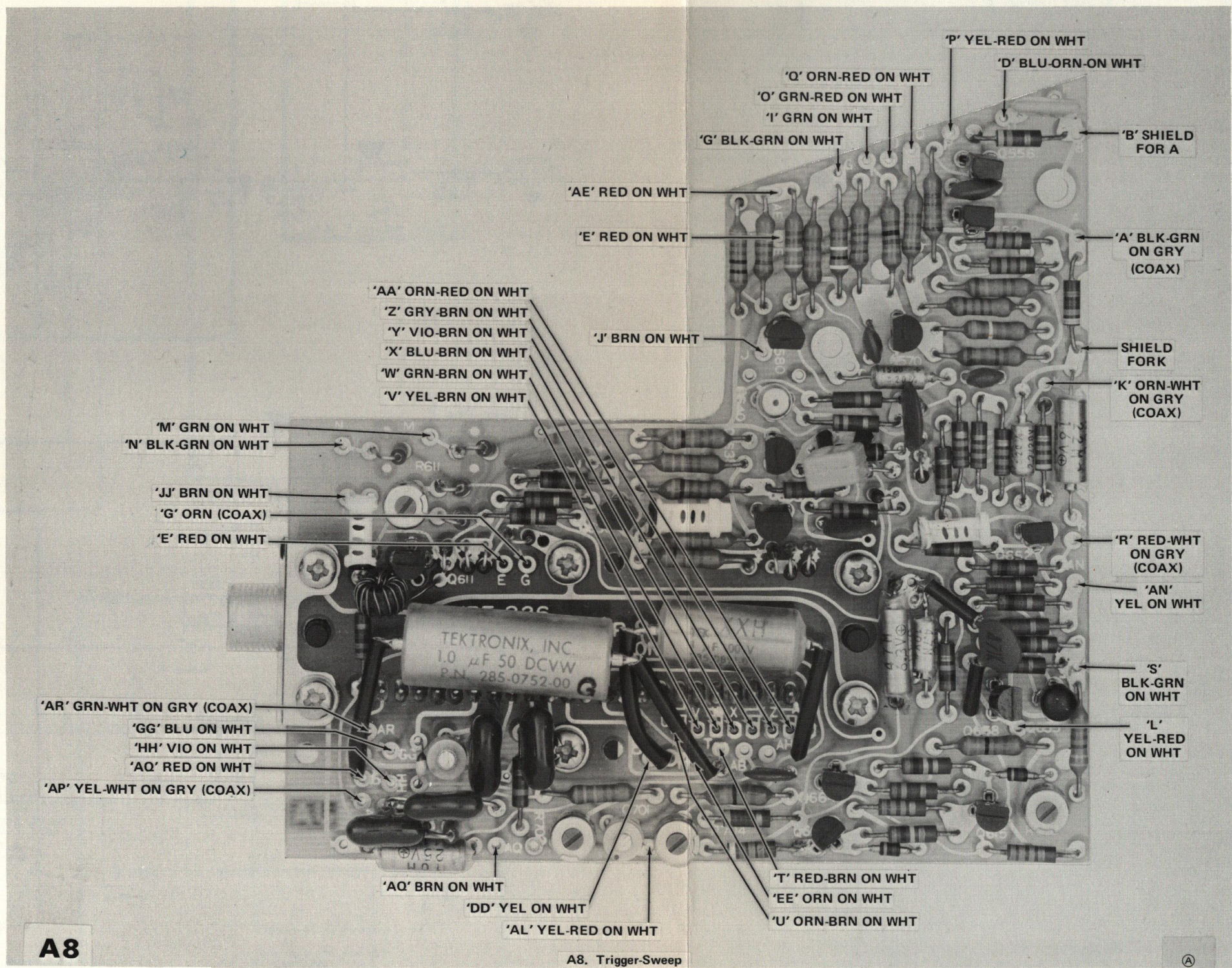

A8

A8. Trigger-Sweep

Ⓐ

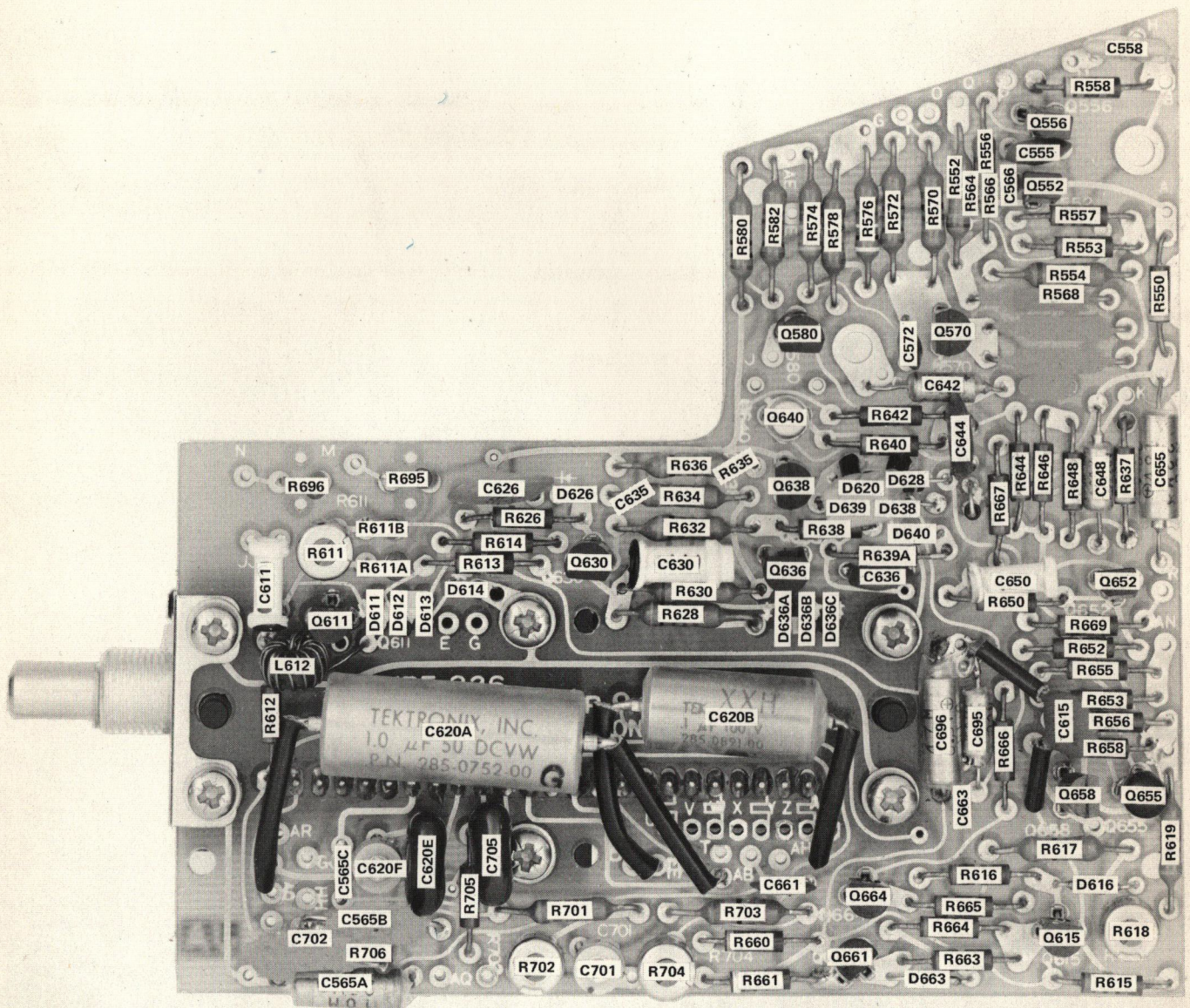

A8

A8. Trigger-Sweep

Ⓐ

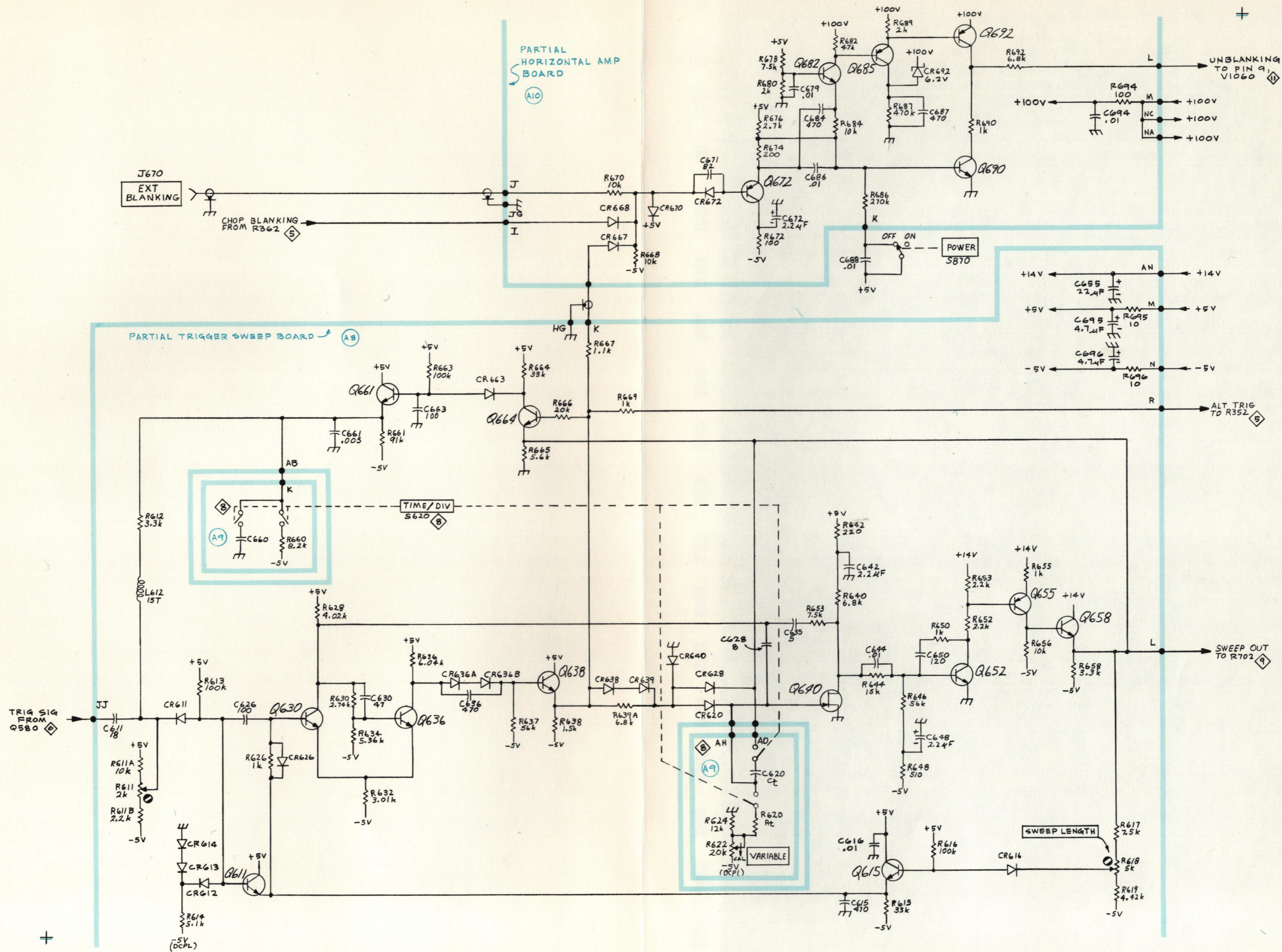

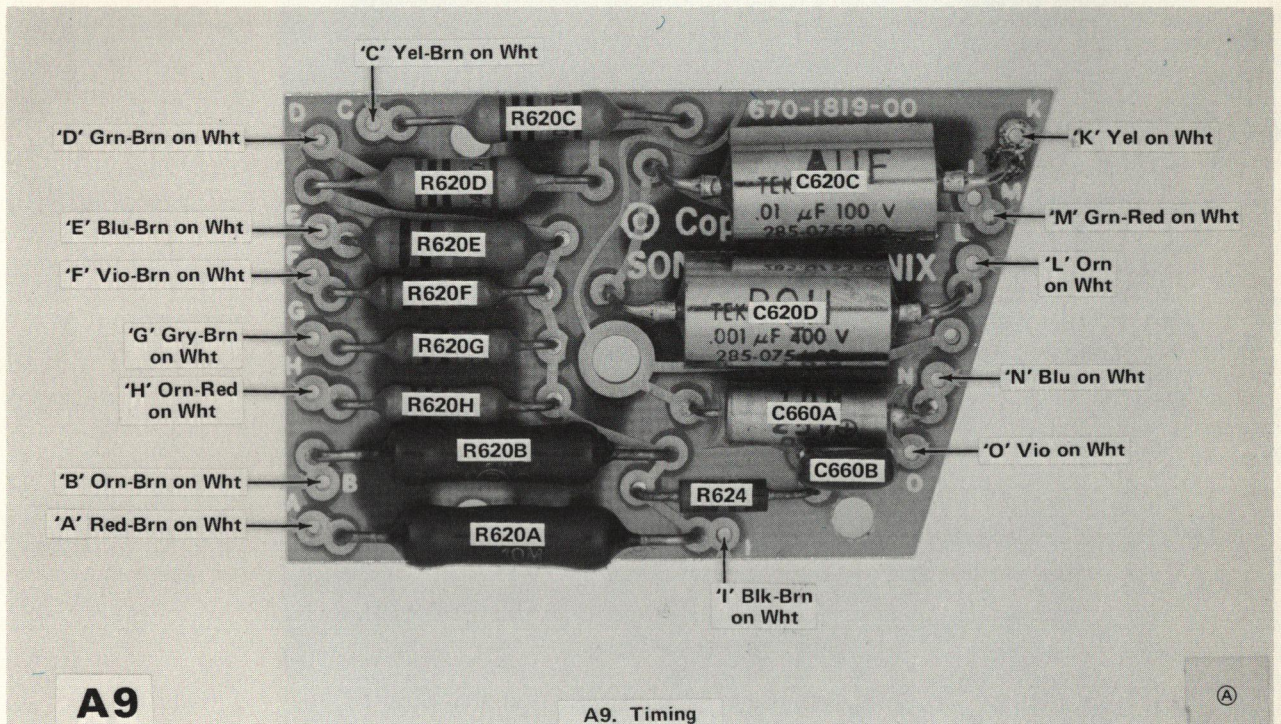

A9

A9. Timing

(A)

S620
TIME / DIV SHOWN IN EXT HORIZ POSITION

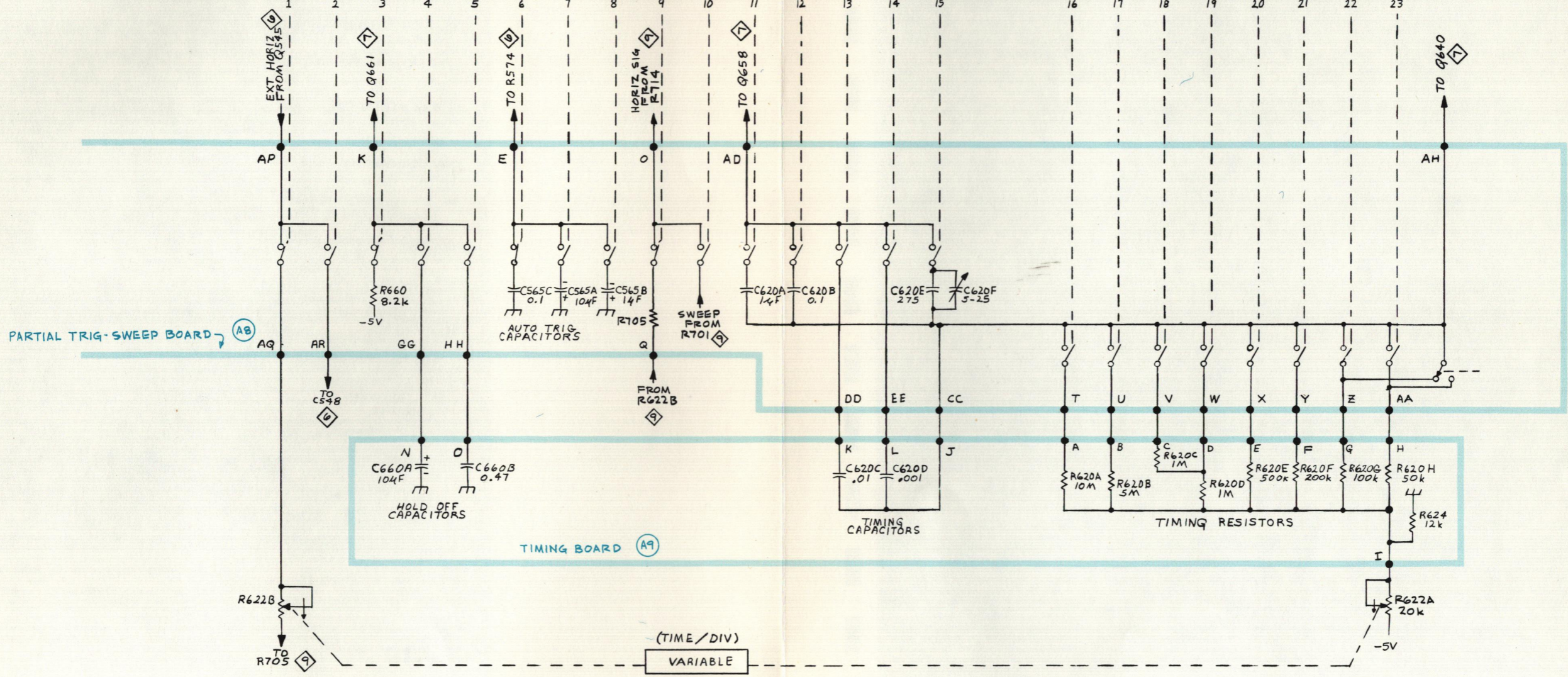
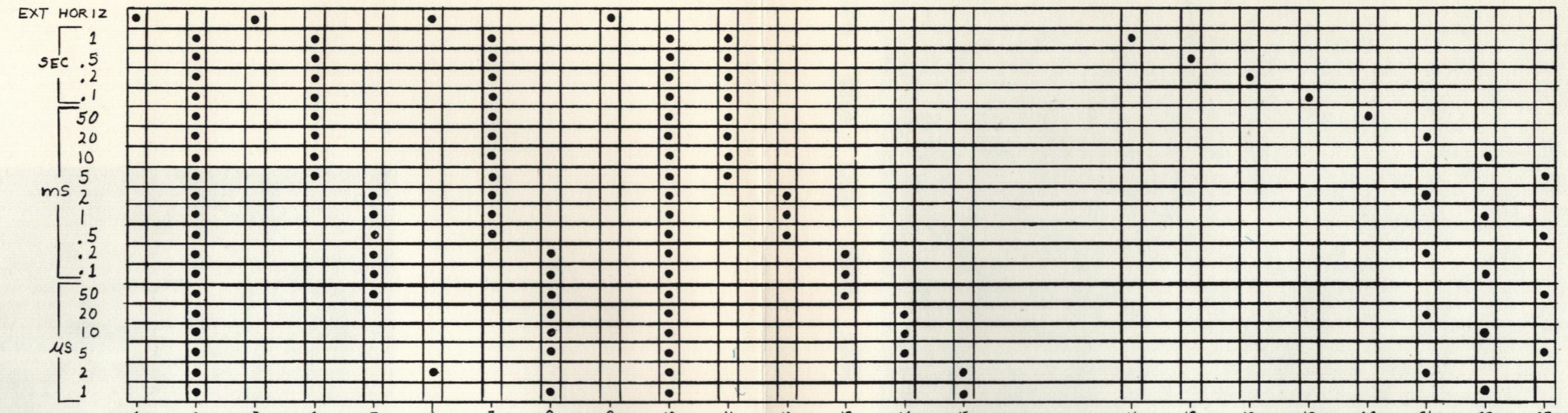

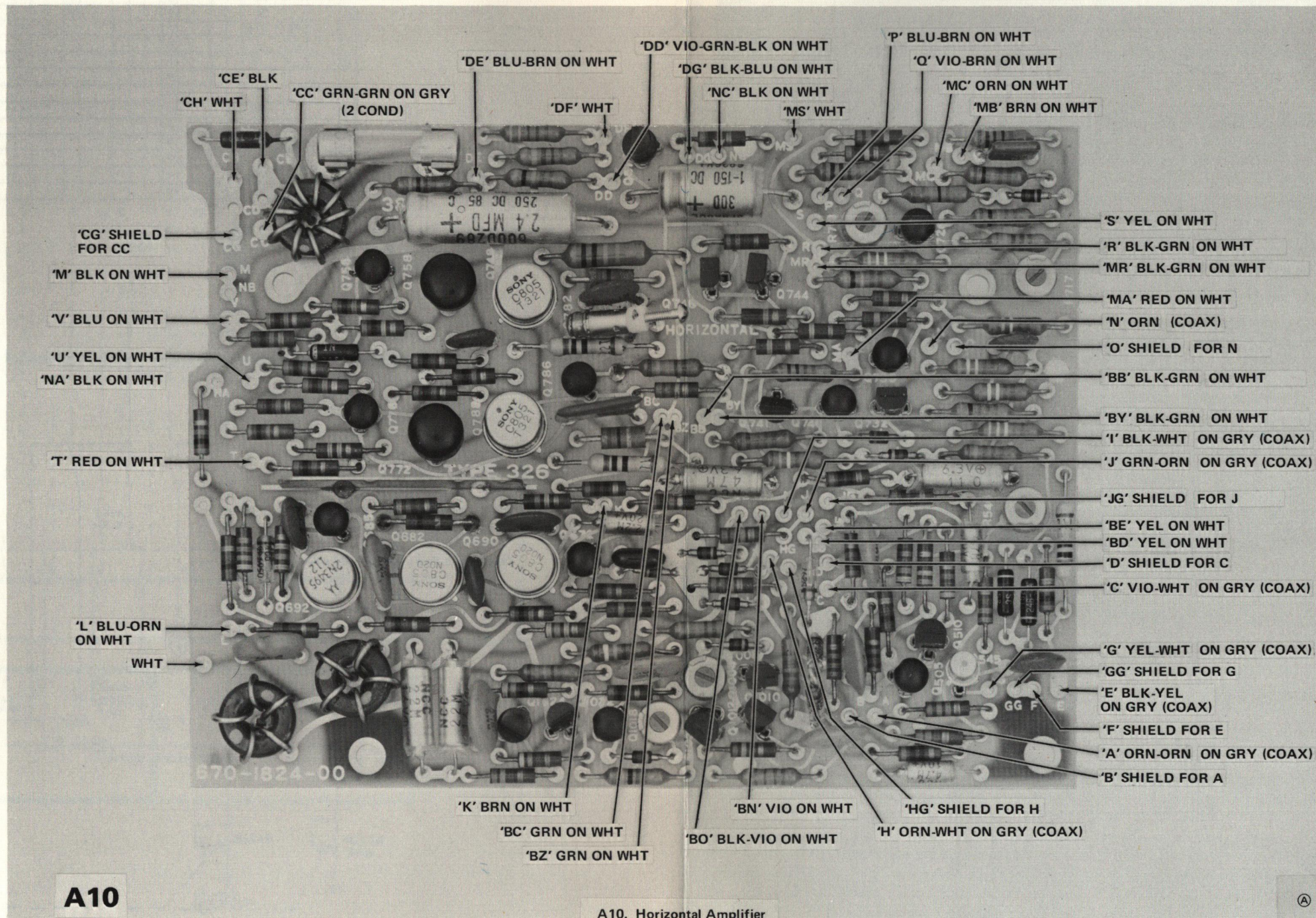

A10

A10. Horizontal Amplifier

Ⓐ

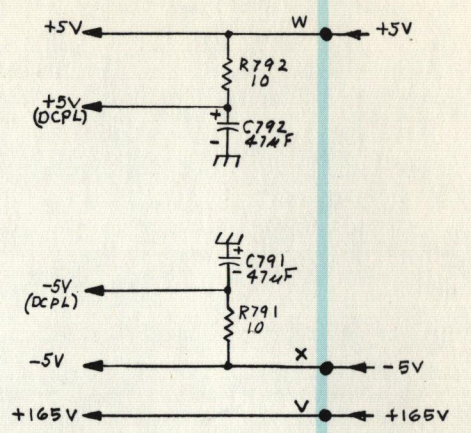
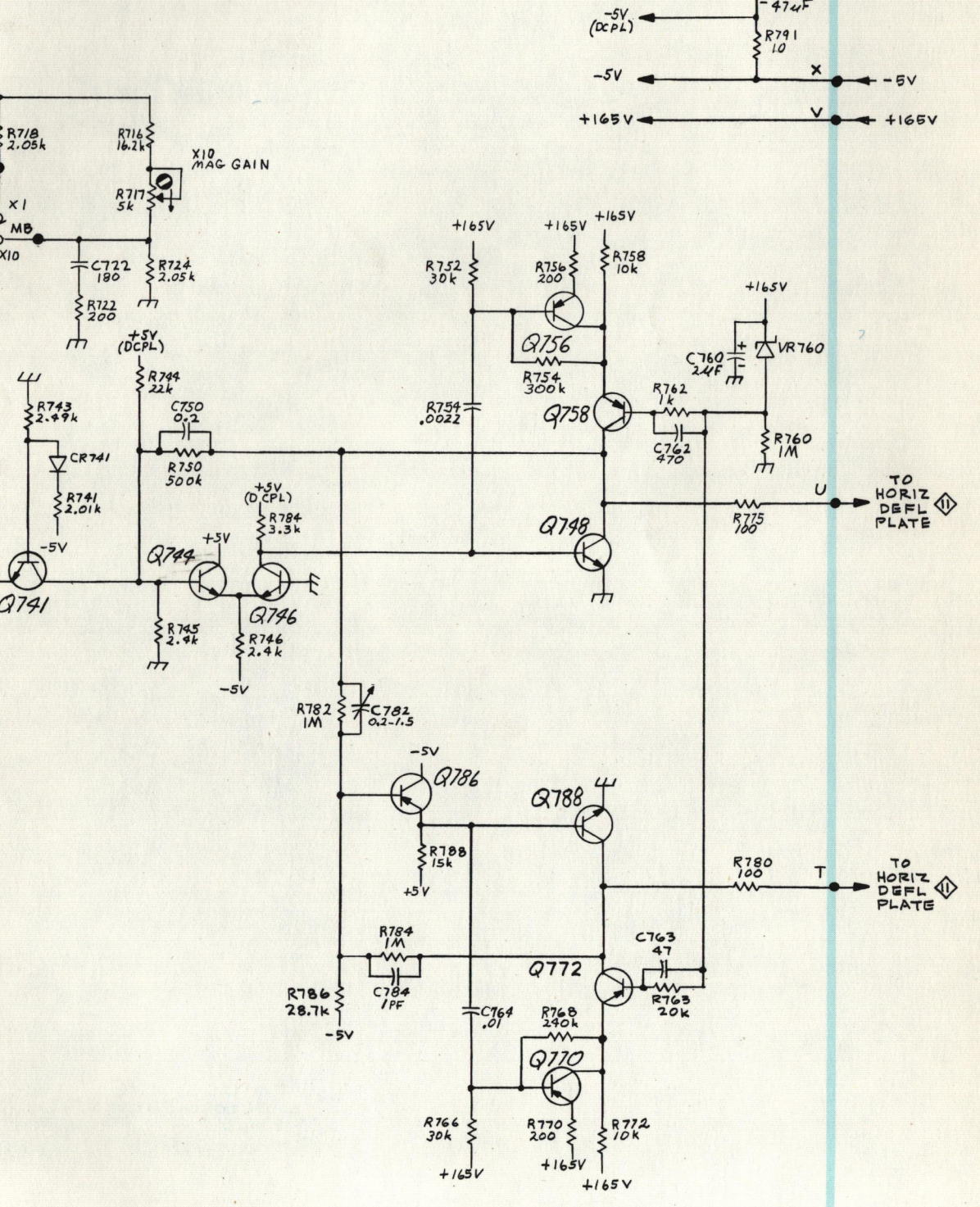
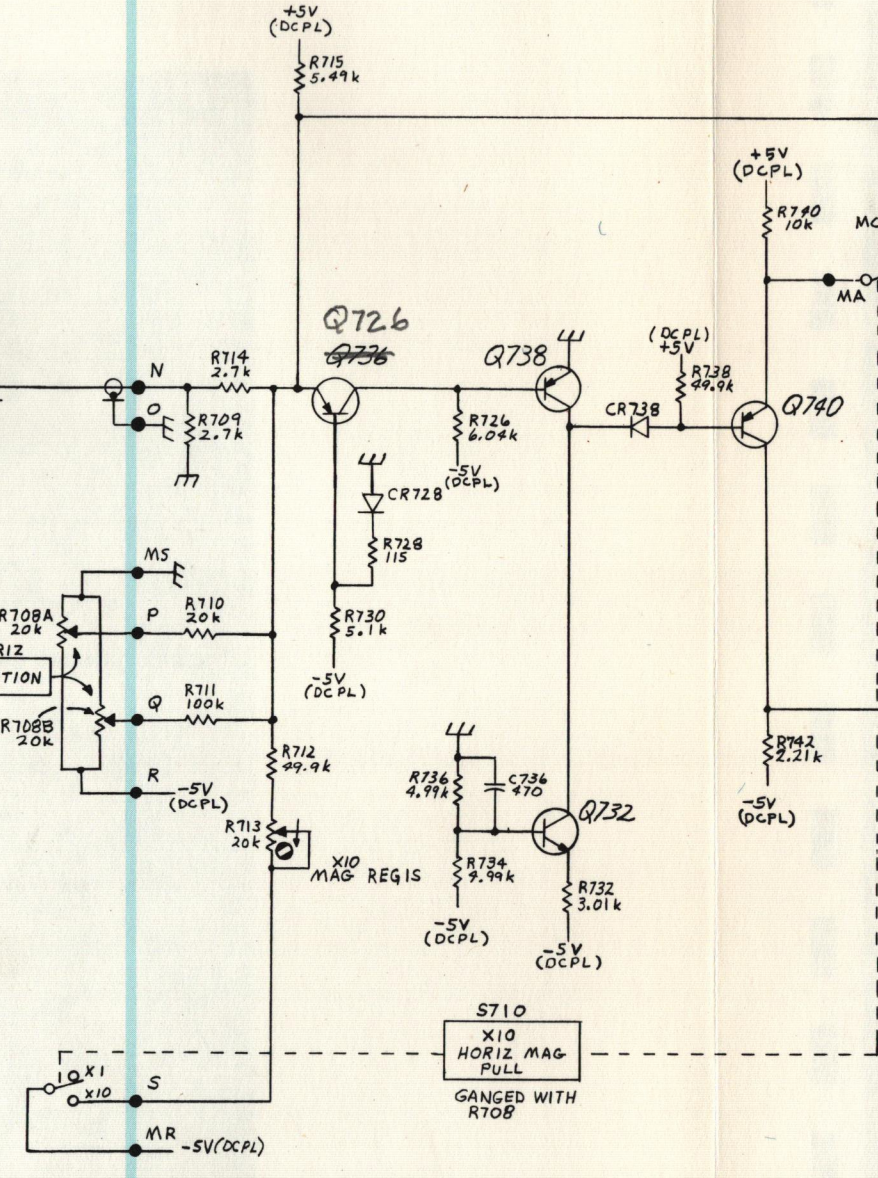
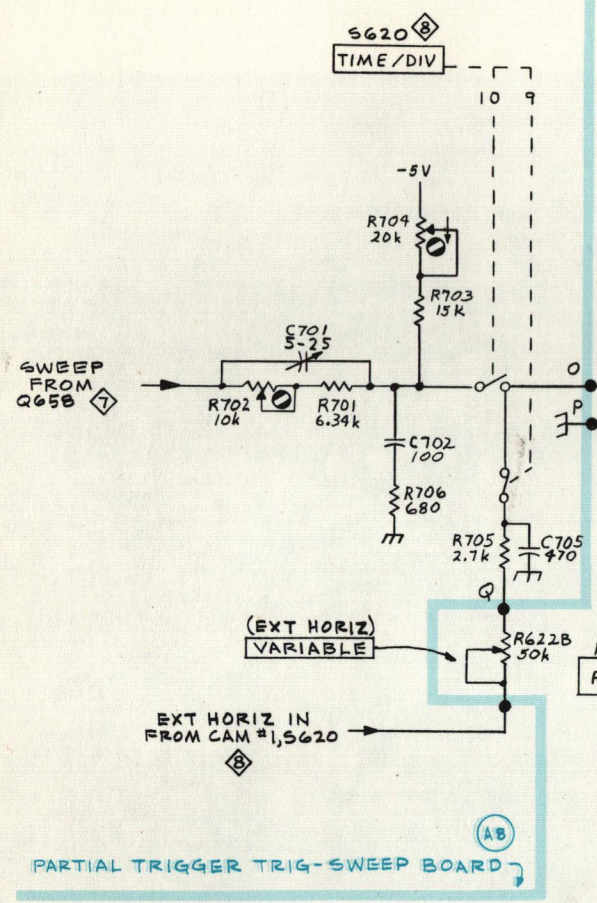

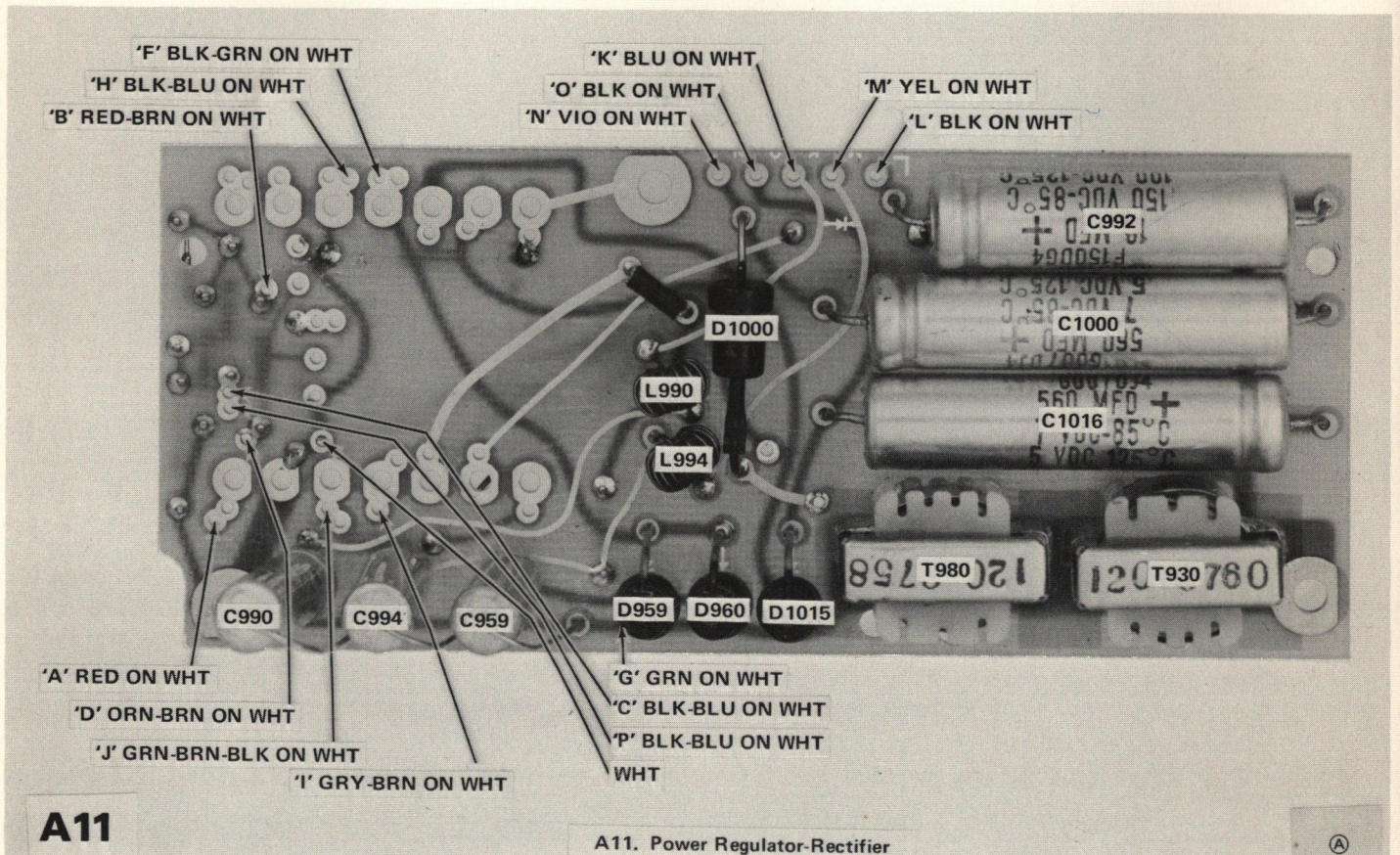

+

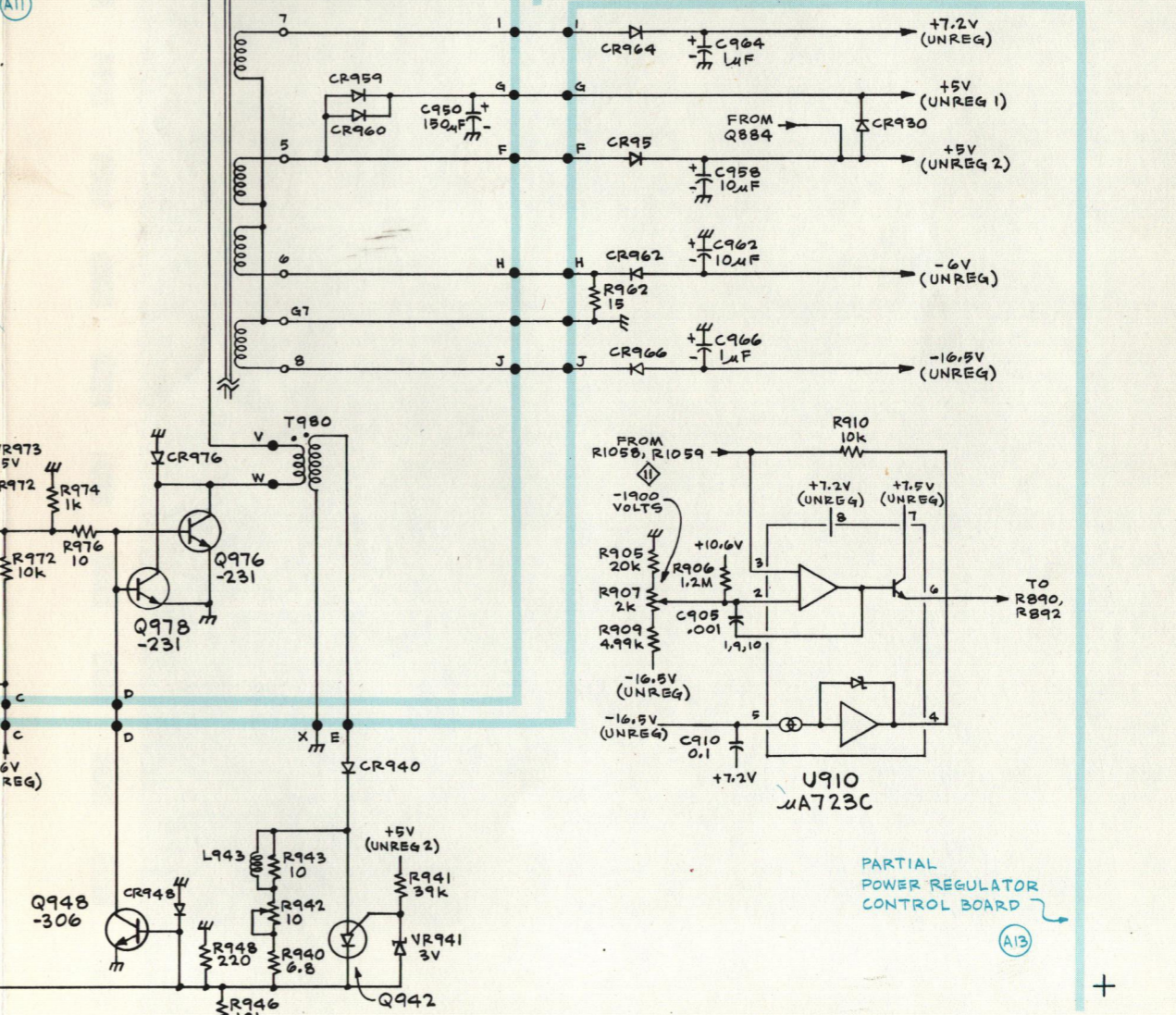
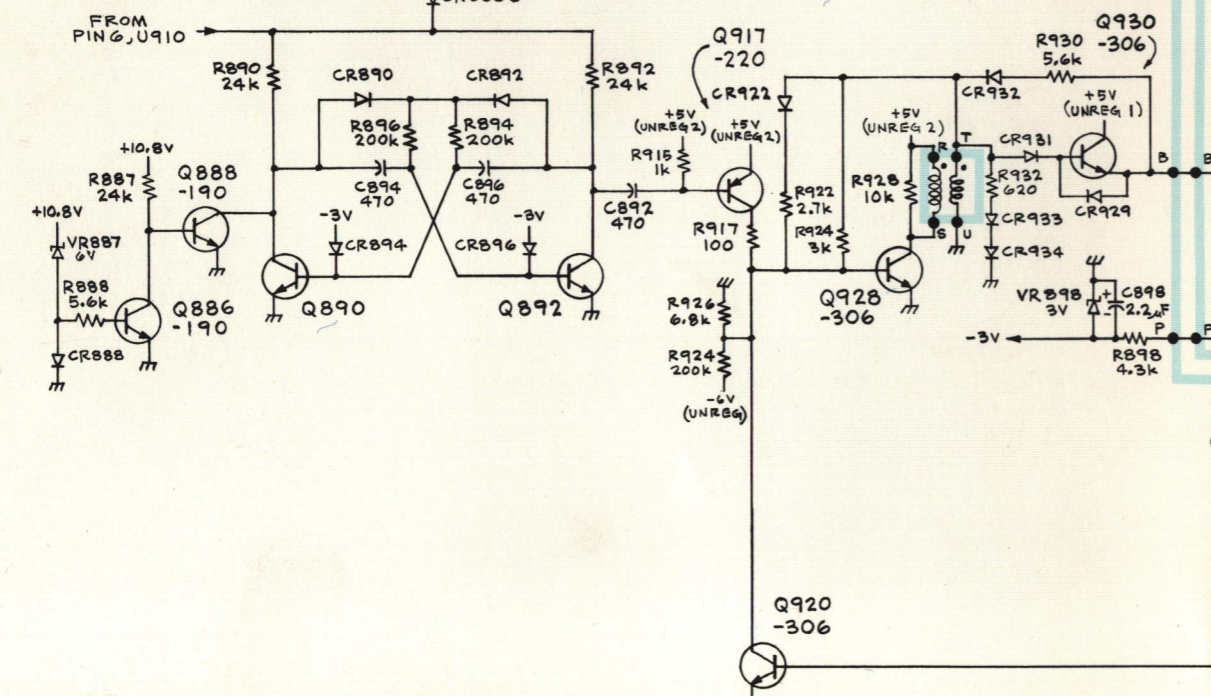
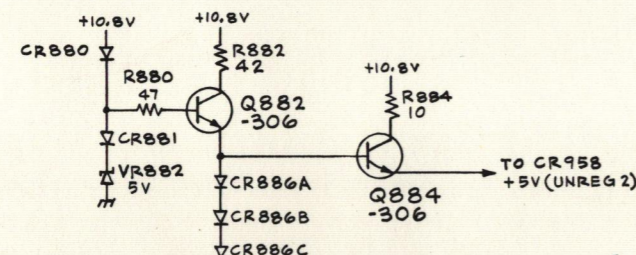
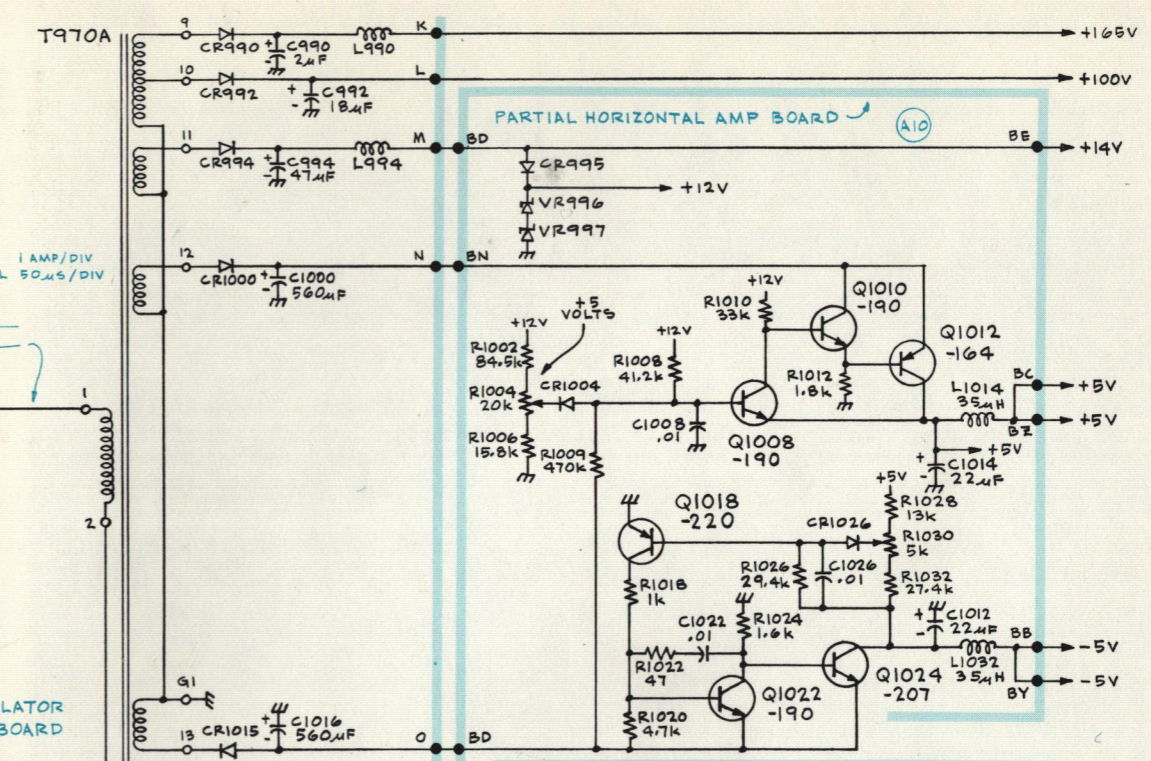
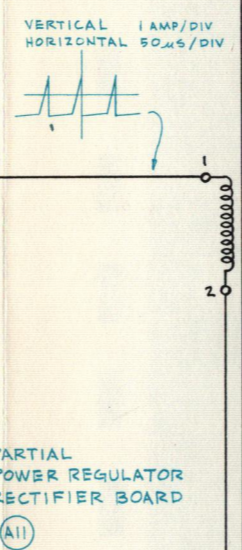
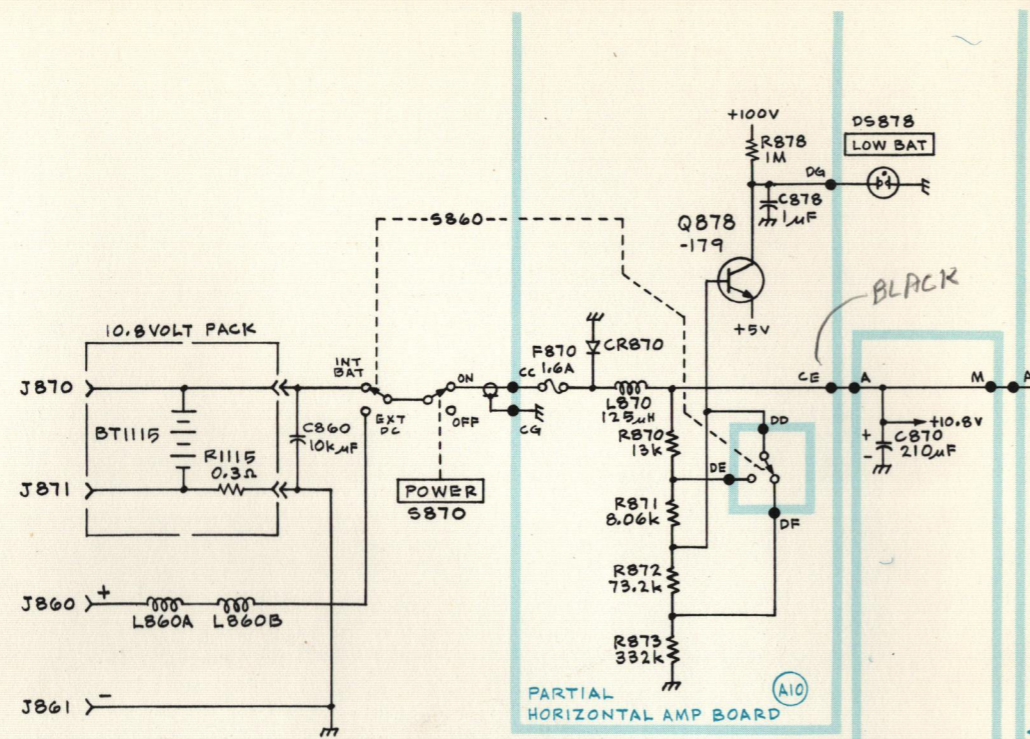

326 OSCILLOSCOPE

POWER SUPPLY

4-6-72

POWER SUPPLY

10

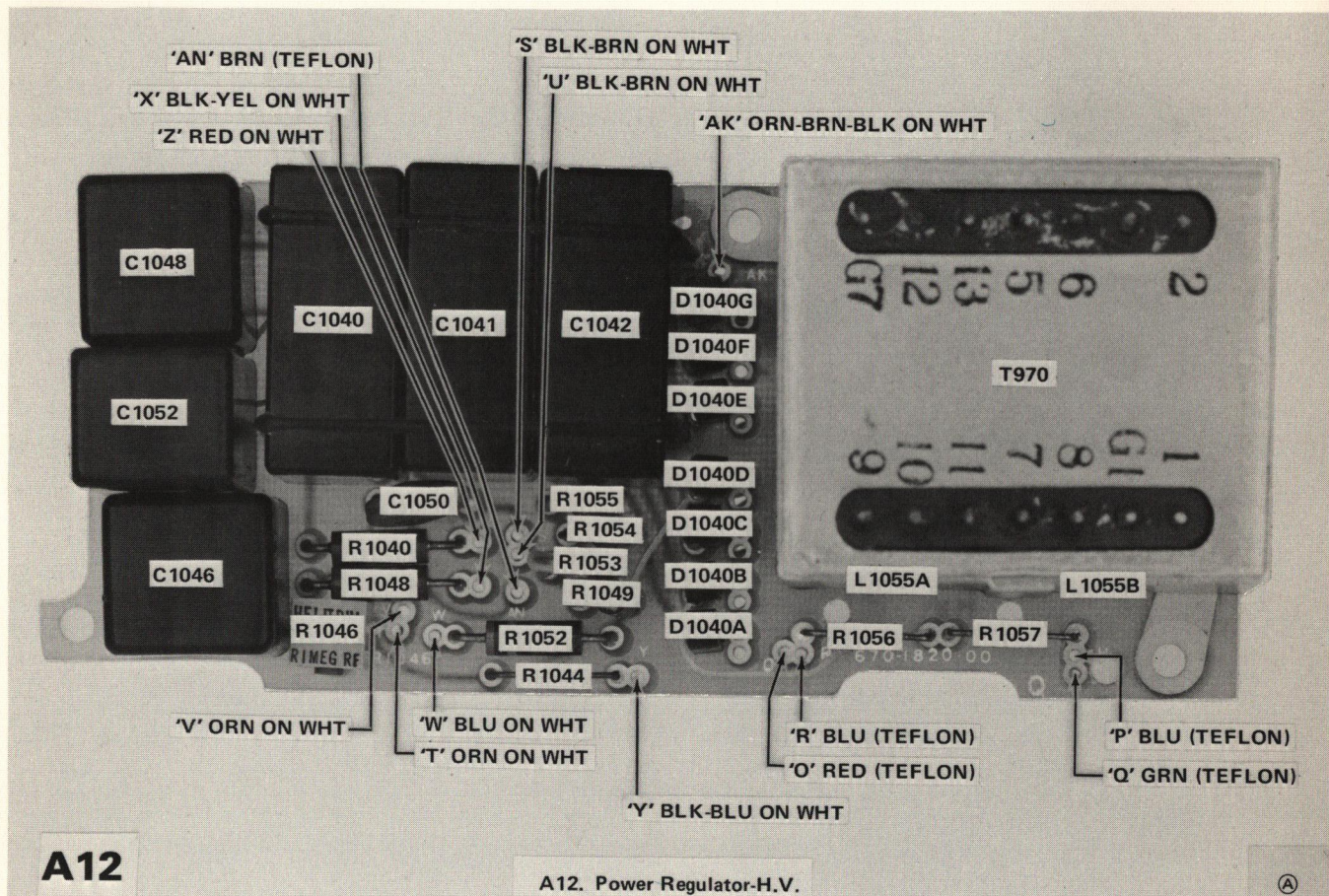

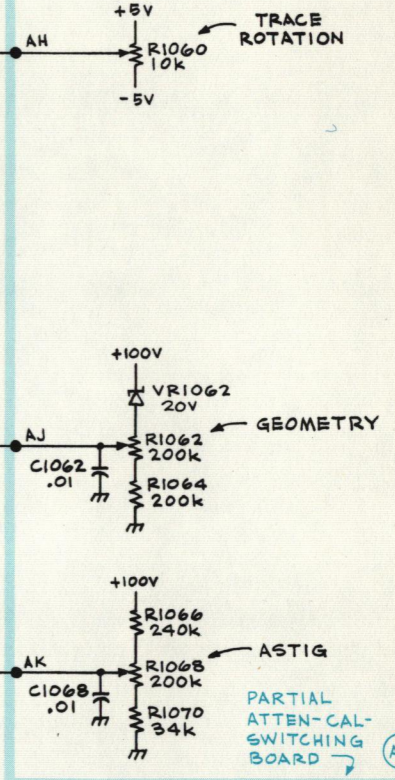
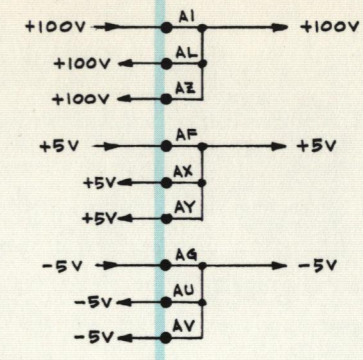
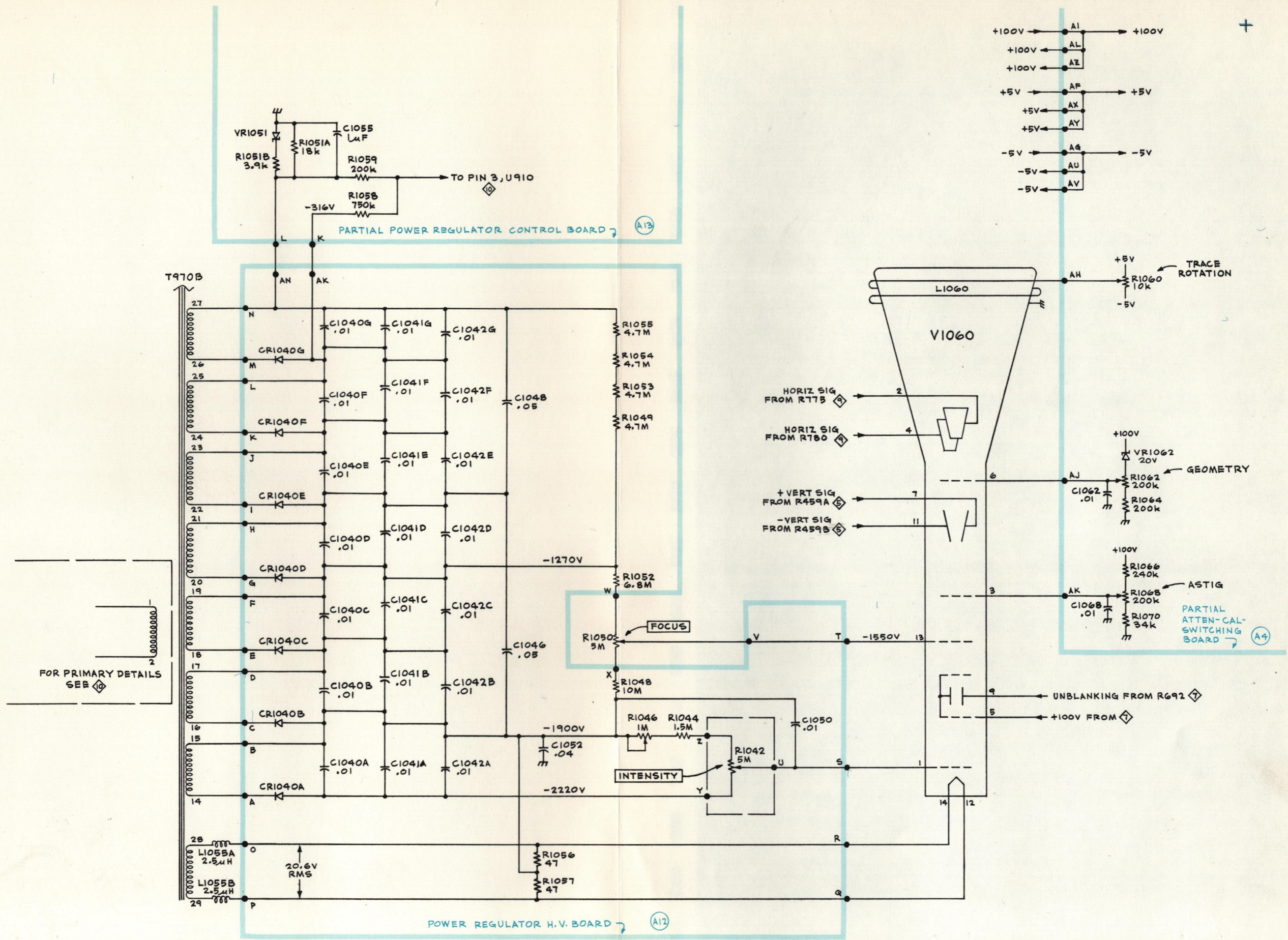

FOR PRIMARY DETAILS SEE [Symbol]

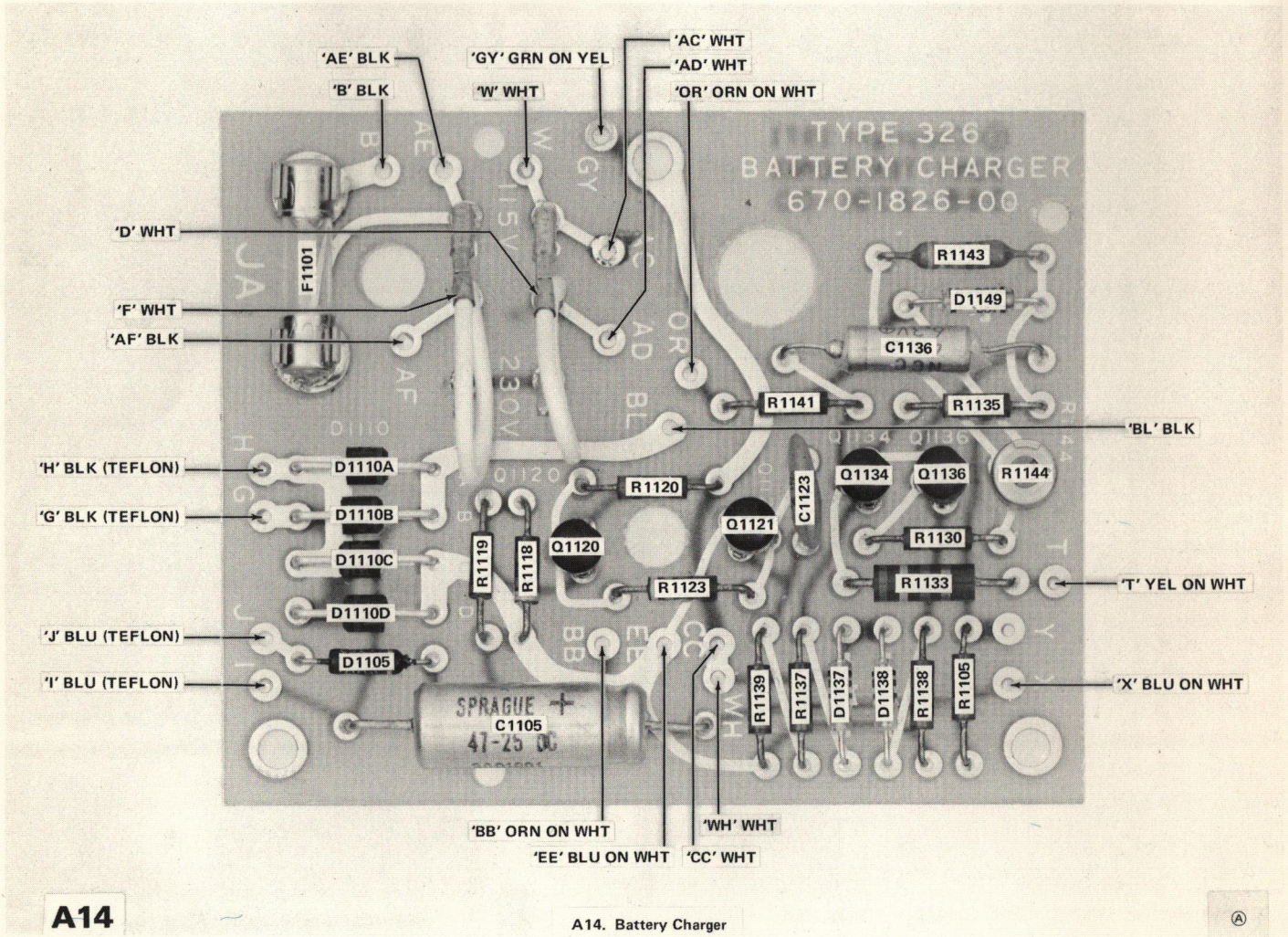

A14

A14. Battery Charger

A

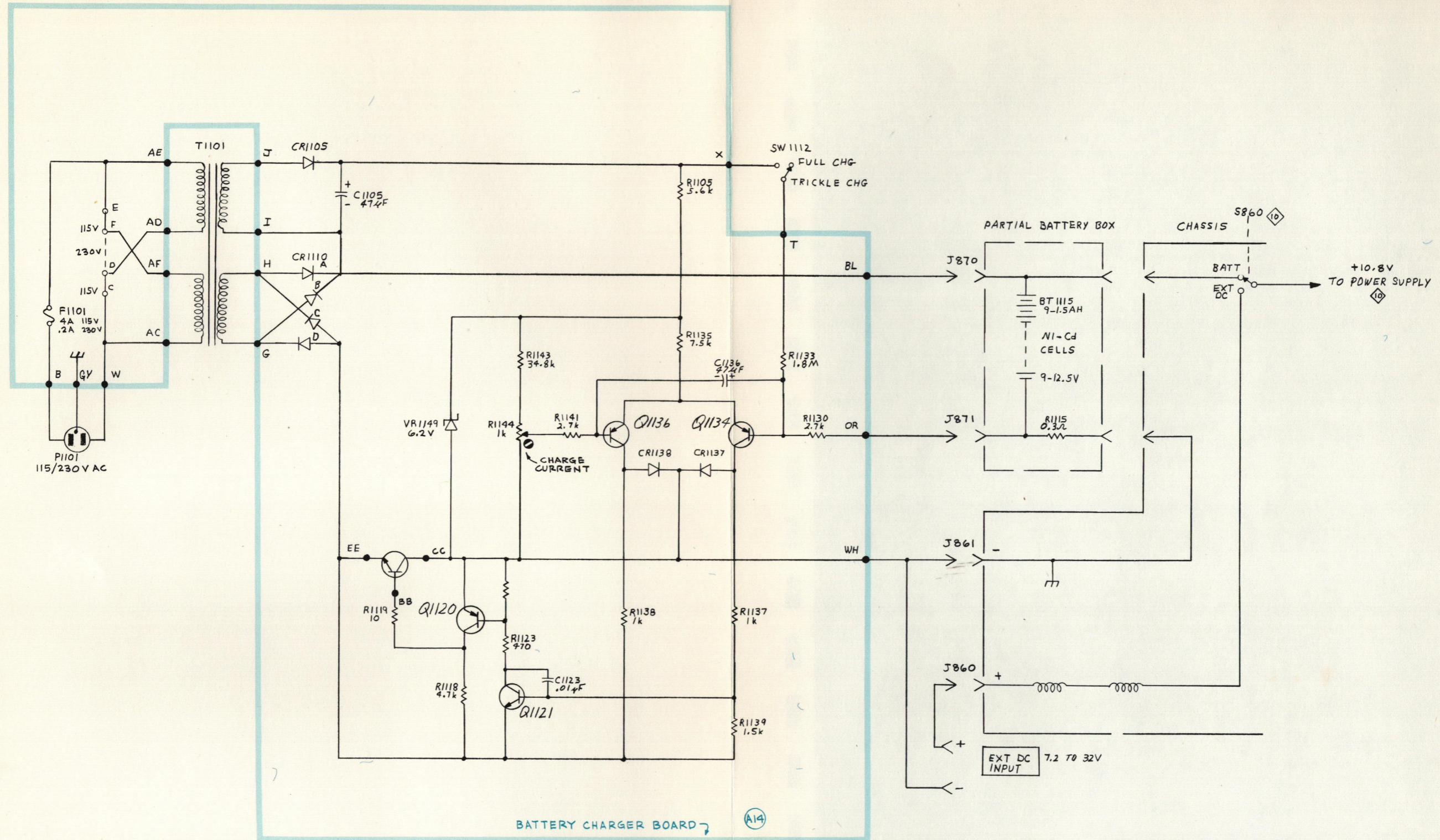

MECHANICAL PARTS LIST

Replacement parts should be ordered from the Tektronix Field Office or Representative in your area. Changes to Tektronix products give you the benefit of improved circuits and components. Please include the instrument type number and serial number with each order for parts or service.

ABBREVIATIONS

| | | | | | |
|--------|----------------------|------|------------------|-----|------------------|
| BHB | binding head brass | h | height or high | OHB | oval head brass |
| BHS | binding head steel | hex. | hexagonal | OHS | oval head steel |
| CRT | cathode-ray tube | HHB | hex head brass | PHB | pan head brass |
| csk | countersunk | HHS | hex head steel | PHS | pan head steel |
| DE | double end | HSB | hex socket brass | RHS | round head steel |
| FHB | flat head brass | HSS | hex socket steel | SE | single end |
| FHS | flat head steel | ID | inside diameter | THB | truss head brass |
| fil HB | fillister head brass | lg | length or long | THS | truss head steel |
| fil HS | fillister head steel | OD | outside diameter | w | wide or width |

FIGURE 1 FRONT & CABINET

| Fig. & Index No. | Tektronix Part No. | Serial/Model No. | | Q t y | Description |
|------------------------|-----------------------|------------------|------|-------------|--|
| | | Eff | Disc | | |
| 1-1 | 390-0253-00 | | | 1 | CABINET TOP |
| | - - - - - | | | - | mounting hardware: (not included w/cabinet top) |
| -2 | 211-0008-00 | | | 4 | SCREW, 4-40 x 0.25 inch, PHS |
| -3 | 342-0142-00 | | | 1 | INSULATION, mylar |
| -4 | 200-1342-00 | | | 2 | COVER, handle |
| -5 | 367-0157-00 | | | 1 | HANDLE, carrying |
| | - - - - - | | | - | mounting hardware: (not included w/handle) |
| -6 | 212-0004-00 | | | 2 | SCREW, 8-32 x 0.312 inch, PHS |
| -7 | 210-0008-00 | | | 2 | WASHER, lock, internal, 0.172 ID x 0.331 inch OD |
| -8 | 210-1144-00 | | | 2 | WASHER, flat, 0.156 ID x 1.125 inches OD |
| -9 | 386-2181-00 | | | 2 | PLATE, ring |
| -10 | 386-2182-00 | | | 4 | PLATE, friction |
| -11 | 211-0559-00 | | | 4 | SCREW, 6-32 x 0.375 inch, 100° csk, FHS |
| -12 | 384-0384-00 | | | 2 | SHAFT, handle friction |
| -13 | 334-1898-00 | | | 1 | PLATE, identification |
| -14 | 390-0254-00 | | | 1 | CABINET BOTTOM |
| | - - - - - | | | - | mounting hardware: (not included w/cabinet bottom) |
| -15 | 211-0008-00 | | | 4 | SCREW, 4-40 x 0.25 inch, PHS |
| -16 | 348-0187-00 | | | 4 | FOOT, cabinet |
| | 426-0871-00 | | | 1 | FRAME-FILTER ASSEMBLY |
| | - - - - - | | | - | frame-filter assembly includes: |
| -17 | 426-0870-00 | | | 1 | FRAME, plastic |
| -18 | 378-0706-00 | | | 1 | FILTER, light |
| -19 | 366-1031-03 | | | 3 | KNOB, red--VARIABLE |
| | - - - - - | | | - | each knob includes: |
| | 213-0153-00 | | | 1 | SETSCREW, 5-40 x 0.125 inch, HSS |
| -20 | 366-1029-00 | | | 3 | KNOB, gray--VOLTS/DIV & TIME/DIV |
| | - - - - - | | | - | each knob includes: |
| | 213-0153-00 | | | 2 | SETSCREW, 5-40 x 0.125 inch, HSS |

FIGURE 1 FRONT & CABINET (cont)

| Fig. & Index No. | Tektronix Part No. | Serial/Model No. | | Q t y | Description |
|------------------------|-----------------------|------------------|------|-------------|---|
| | | Eff | Disc | | |
| 1-21 | 366-1379-00 | | | 3 | KNOB, gray--POSITION |
| | - - - - - | | | - | each knob includes: |
| | 213-0153-00 | | | 1 | SETSCREW, 5-40 x 0.125 inch, HSS |
| -22 | 366-0379-00 | | | 1 | KNOB, gray--MODE |
| | - - - - - | | | - | knob includes: |
| | 213-0153-00 | | | 1 | SETSCREW, 5-40 x 0.125 inch, HSS |
| -23 | 366-1039-00 | | | 1 | KNOB, gray--LEVEL/SLOPE |
| | - - - - - | | | - | knob includes: |
| | 213-0153-00 | | | 1 | SETSCREW, 5-40 x 0.125 inch, HSS |
| -24 | 366-1023-01 | | | 2 | KNOB, gray--INTENSITY & FOCUS |
| | - - - - - | | | - | each knob includes: |
| | 213-0153-00 | | | 1 | SETSCREW, 5-40 x 0.125 inch, HSS |
| -25 | 214-1700-00 | | | 1 | SPRING, flat |
| -26 | 200-1341-00 | | | 2 | COVER, variable resistor |
| -27 | - - - - - | | | 2 | RESISTORS, variable |
| | - - - - - | | | - | mounting hardware for each: (not included w/resistor) |
| -28 | 210-0583-00 | | | 1 | NUT, hex., 0.25-32 x 0.312 inch |
| -29 | 210-0940-00 | | | 1 | WASHER, flat, 0.25 ID x 0.375 inch OD |
| -30 | 210-0046-00 | | | 1 | WASHER, lock, internal, 0.261 ID x 0.40 inch OD |
| -31 | 262-0957-00 | | | 1 | SWITCH, rotary--TRIGGERING, wired |
| | - - - - - | | | - | switch includes: |
| | 260-0886-00 | | | 1 | SWITCH, rotary, unwired |
| -32 | 376-0051-00 | | | 1 | COUPLING, flexible |
| | - - - - - | | | - | coupling includes: |
| | 354-0251-00 | | | 2 | RING, coupling |
| | 376-0049-00 | | | 1 | COUPLING, plastic |
| | 213-0048-00 | | | 4 | SETSCREW, 4-40 x 0.125 inch, HSS |
| -33 | - - - - - | | | 1 | RESISTOR, variable, w/hardware |
| | - - - - - | | | - | mounting hardware: (not included w/resistor) |
| -34 | 210-0046-00 | | | 1 | WASHER, lock, internal, 0.261 ID x 0.40 inch OD |
| | - - - - - | | | - | mounting hardware: (not included w/switch) |
| -35 | 210-0413-00 | | | 1 | NUT, hex., 0.375-32 x 0.50 inch |
| -36 | 210-0978-00 | | | 1 | WASHER, flat, 0.375 ID x 0.50 inch OD |
| -37 | 354-0427-00 | | | 1 | RING, sleeve |
| | 210-0840-00 | | | 1 | WASHER, flat, 0.39 ID x 0.562 inch OD |
| -38 | 210-0012-00 | | | 1 | WASHER, lock, internal, 0.375 ID x 0.50 inch OD |
| -39 | 260-0834-00 | | | 1 | SWITCH, toggle--POWER |
| | - - - - - | | | - | mounting hardware: (not included w/switch) |
| -40 | 210-0562-00 | | | 1 | NUT, hex., 0.25-40 x 0.312 inch |
| | 210-0940-00 | | | 1 | WASHER, flat, 0.25 ID x 0.375 inch OD |
| -41 | 337-1634-00 | | | 1 | SHIELD, electrical, power switch |
| | 210-0046-00 | | | 1 | WASHER, lock, internal, 0.261 ID x 0.40 inch OD |

FIGURE 1 FRONT & CABINET (cont)

| Fig. & Index No. | Tektronix Part No. | Serial/Model No. | | Q | | | | | Description | |
|------------------|--------------------------|------------------|------|----|---|---|---|---|-------------|--|
| | | Eff | Disc | y | 1 | 2 | 3 | 4 | | 5 |
| 1-100 | - - - - - | | | 1 | | | | | | CIRCUIT BOARD ASSEMBLY--ATTENUATOR/CAL |
| | - - - - - | | | - | | | | | | circuit board assembly includes: |
| -101 | 136-0252-04 | | | 21 | | | | | | SOCKET, pin connector |
| -102 | 131-0604-00 | | | 38 | | | | | | CONTACT, electrical |
| -103 | 337-1613-00 | | | 1 | | | | | | SHIELD, electrical |
| | - - - - - | | | - | | | | | | mounting hardware: (not included w/shield) |
| -104 | 211-0079-00 | | | 7 | | | | | | SCREW, 2-56 x 0.188 inch, PHS |
| -105 | 210-0001-00 | | | 7 | | | | | | WASHER, lock, internal, 0.092 ID x 0.18 inch OD |
| -106 | 344-0239-00 | | | 2 | | | | | | CLIP, grounding |
| -107 | - - - - - | | | 2 | | | | | | RESISTOR, variable, w/hardware |
| | - - - - - | | | - | | | | | | mounting hardware for each: (not included w/resistor) |
| -108 | 210-0940-00 | | | 1 | | | | | | WASHER, flat, 0.25 ID x 0.375 inch OD |
| -109 | 386-2183-00 | | | 1 | | | | | | PLATE, mounting |
| -110 | 210-0046-00 | | | 1 | | | | | | WASHER, lock, internal, 0.261 ID x 0.40 inch OD |
| -111 | 337-1618-00 | | | 1 | | | | | | SHIELD, electrical |
| | - - - - - | | | - | | | | | | mounting hardware: (not included w/shield) |
| -112 | 211-0079-00 | | | 2 | | | | | | SCREW, 2-56 x 0.188 inch, PHS |
| -113 | 337-1623-00 | | | 1 | | | | | | SHIELD, electrical, calibrator |
| -114 | 337-1621-00 | | | 1 | | | | | | SHIELD, electrical |
| -115 | 337-1622-00 | | | 1 | | | | | | SHIELD, electrical, attenuator |
| -116 | 337-1619-00 | | | 1 | | | | | | SHIELD, electrical, attenuator |
| | 105-0302-00 | | | 2 | | | | | | ACTUATOR ASSEMBLY--VOLTS/DIV |
| | - - - - - | | | - | | | | | | each actuator assembly includes: |
| | 200-1323-00 | | | 1 | | | | | | COVER |
| | - - - - - | | | - | | | | | | mounting hardware: (not included w/cover) |
| | 211-0022-00 | | | 2 | | | | | | SCREW, 2-56 x 0.188 inch, PHS |
| | 210-0001-00 | | | 2 | | | | | | WASHER, lock, internal, 0.092 ID x 0.18 inch OD |
| -117 | 354-0219-00 ¹ | | | 1 | | | | | | RING, retaining |
| -118 | 214-1126-00 ¹ | | | - | | | | | | SPRING, flat, gold |
| | 214-1126-02 ¹ | | | - | | | | | | SPRING, flat, green |
| | 214-1126-03 ¹ | | | - | | | | | | SPRING, flat, red |
| -119 | 214-1127-00 | | | 1 | | | | | | ROLLER, detent |
| -120 | 401-0053-00 | | | 1 | | | | | | BEARING, front |
| -121 | 210-0405-00 | | | 2 | | | | | | NUT, hex., 2-56 x 0.188 inch |
| -122 | 105-0304-00 | | | 1 | | | | | | DRUM ASSEMBLY |
| -123 | 401-0061-00 | | | 1 | | | | | | BEARING, rear |
| -124 | 407-0714-00 | | | 1 | | | | | | BRACKET, grounding |
| -125 | 211-0116-00 | | | 4 | | | | | | SCREW, sems, 4-40 x 0.312 inch, PHB |
| -126 | 210-0406-00 | | | 4 | | | | | | NUT, hex., 4-40 x 0.188 inch |
| | - - - - - | | | - | | | | | | mounting hardware: (not included w/circuit board assembly) |
| -127 | 211-0116-00 | | | 1 | | | | | | SCREW, sems, 4-40 x 0.312 inch, PHB |
| -128 | 352-0311-00 | | | 1 | | | | | | HOLDER, double angle |
| -129 | 210-0413-00 | | | 2 | | | | | | NUT, hex., 0.375-32 x 0.50 inch |
| -130 | 210-0840-00 | | | 2 | | | | | | WASHER, flat, 0.39 ID x 0.562 inch OD |
| -131 | 354-0427-00 | | | 2 | | | | | | RING, sleeve |

¹Replace only with part bearing the same color code as the original part in your instrument.

FIGURE 1 FRONT & CABINET (cont)

| Fig. & Index No. | Tektronix Part No. | Serial/Model No. | | Q | | | | | Description | | |
|------------------------|-----------------------|------------------|------|---|---|---|---|---|-------------|---|--|
| | | Eff | Disc | t | y | 1 | 2 | 3 | | 4 | 5 |
| 1-132 | 384-1377-00 | | | | | 1 | | | | | 1 KNOB, w/extension--INVERT |
| -133 | 384-1133-00 | | | | | 1 | | | | | 1 SHAFT, extension |
| | - - - - - | | | | | - | | | | | mounting hardware: (not included w/shaft) |
| -134 | 211-0001-00 | | | | | 2 | | | | | 2 SCREW, 2-56 x 0.25 inch, PHS |
| -135 | 210-0001-00 | | | | | 2 | | | | | 2 WASHER, lock, internal, 0.092 ID x 0.18 inch OD |
| -136 | 129-0359-00 | | | | | 1 | | | | | 1 POST, CH 2 invert switch |
| -137 | 376-0135-00 | | | | | 1 | | | | | 1 COUPLER, invert switch |
| -138 | 333-1547-00 | | | | | 1 | | | | | 1 PANEL, front |
| -139 | 131-0251-00 | | | | | 1 | | | | | 1 CONNECTOR, terminal jack |
| -140 | 200-0609-00 | | | | | 1 | | | | | 1 BASE, lampholder |
| -141 | 378-0541-00 | | | | | 1 | | | | | 1 FILTER |
| -142 | 352-0084-01 | | | | | 1 | | | | | 1 HOLDER |
| -143 | - - - - - | | | | | 1 | | | | | 1 CIRCUIT BOARD ASSEMBLY, switch--TRIG. SOURCE (See A6 |
| | - - - - - | | | | | - | | | | | electrical list) |
| | - - - - - | | | | | - | | | | | mounting hardware: (not included w/circuit board assembly) |
| -144 | 211-0156-00 | | | | | 1 | | | | | 1 SCREW, 1-72 x 0.25 inch, 82° csk, FHS |
| -145 | - - - - - | | | | | 1 | | | | | 1 CIRCUIT BOARD ASSEMBLY, switch--TRIG. SOURCE COUPLING (See |
| | - - - - - | | | | | - | | | | | A7 electrical list) |
| | - - - - - | | | | | - | | | | | mounting hardware: (not included w/circuit board assembly) |
| | 211-0156-00 | | | | | 2 | | | | | 2 SCREW, 1-72 x 0.25 inch, 82° csk, FHS |
| -146 | - - - - - | | | | | 1 | | | | | 1 CIRCUIT BOARD ASSEMBLY, switch-- AC DC CH1 (See A1 |
| | - - - - - | | | | | - | | | | | electrical list) |
| | - - - - - | | | | | - | | | | | mounting hardware: (not included w/circuit board assembly) |
| | 211-0156-00 | | | | | 1 | | | | | 1 SCREW, 1-72 x 0.25 inch, 82° csk, FHS |
| -147 | - - - - - | | | | | 1 | | | | | 1 CIRCUIT BOARD ASSEMBLY, switch--AC DC CH2 (See A2 electrical |
| | - - - - - | | | | | - | | | | | list) |
| | - - - - - | | | | | - | | | | | mounting hardware: (not included w/circuit board assembly) |
| -148 | 211-0156-00 | | | | | 1 | | | | | 1 SCREW, 1-72 x 0.25 inch, 82° csk, FHS |
| -149 | 407-1042-00 | | | | | 1 | | | | | 1 BRACKET, slide switch |
| | - - - - - | | | | | - | | | | | mounting hardware: (not included w/bracket) |
| -150 | 211-0101-00 | | | | | 3 | | | | | 3 SCREW, 4-40 x 0.25 inch, 100° csk, FHS |
| -151 | 331-0301-00 | | | | | 1 | | | | | 1 MASK, CRT |
| -152 | 342-0140-00 | | | | | 1 | | | | | 1 INSULATOR, mylar, CRT shield top |
| -153 | 348-0031-00 | | | | | 1 | | | | | 1 GROMMET, plastic |
| -154 | 337-1620-00 | | | | | 1 | | | | | 1 SHIELD, CRT, 0.125 inch ID |
| -155 | 386-2177-01 | | | | | 1 | | | | | 1 SUBPANEL, front |
| -156 | 426-0873-00 | | | | | 1 | | | | | 1 FRAME SECTION, cabinet left |
| | - - - - - | | | | | - | | | | | mounting hardware: (not included w/frame section) |
| | 211-0633-00 | | | | | 4 | | | | | 4 SCREW, 6-32 x 4.50 mm, 100° csk, FHS |

FIGURE 1 FRONT & CABINET (cont)

| Fig. & Index No. | Tektronix Part No. | Serial/Model No. | | Q † y | Description |
|------------------------|-----------------------|------------------|------|-------------|--|
| | | Eff | Disc | | |
| 1-71 | 344-0237-00 | | | 1 | CLIP, grounding |
| -72 | 361-0466-00 | | | 1 | SPACER, plastic |
| -73 | 361-0452-00 | | | 1 | SPACER |
| | - - - - - | | | - | mounting hardware: (not included w/spacer) |
| -74 | 211-0116-00 | | | 1 | SCREW, sems, 4-40 x 0.312 inch, PHB |
| | - - - - - | | | - | mounting hardware: (not included w/circuit board assembly) |
| | 211-0116-00 | | | 1 | SCREW, sems, 4-40 x 0.312 inch, PHB |
| -75 | 210-0413-00 | | | 1 | NUT, hex., 0.375-32 x 0.50 inch |
| -76 | 210-0978-00 | | | 1 | WASHER, flat, 0.375 ID x 0.50 inch OD |
| -77 | 354-0427-00 | | | 1 | RING, sleeve |
| | - - - - - | | | 1 | CIRCUIT BOARD ASSEMBLY--TIMING (see A9 electrical list) |
| | - - - - - | | | - | mounting hardware: (not included w/circuit board assembly) |
| -79 | 210-0406-00 | | | 1 | NUT, hex., 4-40 x 0.188 inch |
| -80 | 210-0054-00 | | | 1 | WASHER, lock, split, 0.118 ID x 0.212 inch OD |
| -81 | 210-0994-00 | | | 1 | WASHER, flat, 0.125 ID x 0.25 inch OD |
| -82 | 348-0055-00 | | | 1 | GROMMET, plastic, 0.25 inch diameter |
| -83 | 354-0428-00 | | | 1 | RING, coupling, mode switch |
| | 213-0075-00 | | | 6 | SETSCREW, 4-40 x 0.094 inch, HSS |
| -84 | 354-0426-00 | | | 2 | RING, coupling, shaft |
| -85 | 384-1132-00 | | | 1 | SHAFT, extension, Vert. mode switch |
| -86 | 384-0833-00 | | | 2 | SHAFT, U position, plastic |
| -87 | 260-1367-00 | | | 1 | SWITCH, rotary--MODE, unwired |
| | - - - - - | | | - | mounting hardware: (not included w/switch) |
| -88 | 210-0583-00 | | | 1 | NUT, hex., 0.25-32 x 0.312 inch |
| -89 | 210-0940-00 | | | 1 | WASHER, flat, 0.25 ID x 0.375 inch OD |
| -90 | 210-0046-00 | | | 1 | WASHER, lock, internal, 0.261 ID x 0.40 inch OD |
| | - - - - - | | | 2 | RESISTOR, variable, w/hardware |
| | - - - - - | | | - | mounting hardware for each: (not included w/resistor) |
| -92 | 210-0940-00 | | | 1 | WASHER, flat, 0.25 ID x 0.375 inch OD |
| -93 | 210-0046-00 | | | 1 | WASHER, lock, internal, 0.261 ID x 0.40 inch OD |
| | - - - - - | | | 1 | BRACKET, variable resistor |
| -94 | 407-1037-00 | | | 1 | BRACKET, variable resistor |
| -95 | 260-0905-02 | | | 2 | SWITCH, slide--X10 VERT GAIN |
| | - - - - - | | | - | mounting hardware for each: (not included w/switch) |
| -96 | 211-0073-00 | | | 2 | SCREW, 2-56 x 0.218 inch, 82° csk, FHS |
| | - - - - - | | | 1 | BRACKET, slide switch |
| -97 | 407-1039-00 | | | 1 | BRACKET, slide switch |
| | - - - - - | | | - | mounting hardware: (not included w/bracket) |
| -98 | 211-0101-00 | | | 5 | SCREW, 4-40 x 0.25 inch, 100° csk, FHS |
| | - - - - - | | | 1 | BRACKET, support, slide switch |
| -99 | 407-1038-00 | | | 1 | BRACKET, support, slide switch |

FIGURE 1 FRONT & CABINET (cont)

| Fig. & Index No. | Tektronix Part No. | Serial/Model No. | | Q | | | | | Description | | |
|------------------|--------------------------|------------------|------|---|---|----|---|---|-------------|---|--|
| | | Eff | Disc | t | y | 1 | 2 | 3 | | 4 | 5 |
| 1-42 | 343-0119-00 | | | | | 1 | | | | | CLAMP, cable, 0.094 inch diameter |
| | - - - - - | | | | | - | | | | | mounting hardware: (not included w/clamp) |
| -43 | 211-0079-00 | | | | | 1 | | | | | SCREW, 2-56 x 0.188 inch, PHS |
| -44 | 210-0994-00 | | | | | 1 | | | | | WASHER, flat, 0.125 ID x 0.25 inch OD |
| -45 | - - - - - | | | | | 1 | | | | | RESISTOR, variable, w/hardware |
| | - - - - - | | | | | - | | | | | mounting hardware: (not included w/resistor) |
| -46 | 210-0940-00 | | | | | 1 | | | | | WASHER, flat, 0.25 ID x 0.375 inch OD |
| | 210-0046-00 | | | | | 1 | | | | | WASHER, lock, internal, 0.261 ID x 0.40 inch OD |
| -47 | 407-1043-00 | | | | | 1 | | | | | BRACKET, variable resistor |
| -48 | 129-0378-00 | | | | | 1 | | | | | POST |
| -49 | 260-0905-03 | | | | | 1 | | | | | SWITCH, slide--X10 HORIZ MAG |
| | - - - - - | | | | | - | | | | | mounting hardware: (not included w/switch) |
| -50 | 211-0079-00 | | | | | 2 | | | | | SCREW, 2-56 x 0.188 inch, PHS |
| -51 | 210-0001-00 | | | | | 2 | | | | | WASHER, lock, internal, 0.092 ID x 0.18 inch OD |
| | 672-0040-00 | | | | | 1 | | | | | CIRCUIT BOARD ASSEMBLY--TRIGGER SWEEP/TIMING |
| | - - - - - | | | | | - | | | | | circuit board assembly includes: |
| -52 | - - - - - | | | | | - | | | | | CIRCUIT BOARD ASSEMBLY--TRIGGER SWEEP (See A8 electrical list) |
| | - - - - - | | | | | - | | | | | circuit board assembly includes: |
| -53 | 136-0252-04 | | | | | 45 | | | | | SOCKET, pin connector |
| -54 | 131-0604-00 | | | | | 23 | | | | | CONTACT, electrical |
| | 105-0301-00 | | | | | 1 | | | | | ACTUATOR ASSEMBLY--TIME/DIV |
| | - - - - - | | | | | - | | | | | actuator assembly includes: |
| -55 | 200-1324-00 | | | | | 1 | | | | | COVER |
| | - - - - - | | | | | - | | | | | mounting hardware: (not included w/cover) |
| -56 | 211-0022-00 | | | | | 4 | | | | | SCREW, 2-56 x 0.188 inch, PHS |
| -57 | 210-0001-00 | | | | | 4 | | | | | WASHER, lock, internal, 0.092 ID x 0.18 inch OD |
| -58 | 210-0405-00 | | | | | 4 | | | | | NUT, hex., 2-56 x 0.188 inch |
| -59 | 354-0219-00 | | | | | 1 | | | | | RING, retaining |
| -60 | 214-1139-00 ¹ | | | | | - | | | | | SPRING, flat, gold |
| | 214-1139-02 ¹ | | | | | - | | | | | SPRING, flat, green |
| | 214-1139-03 ¹ | | | | | - | | | | | SPRING, flat, red |
| -61 | 214-1127-00 | | | | | 1 | | | | | ROLLER, detent |
| -62 | 401-0054-00 | | | | | 1 | | | | | BEARING, front |
| -63 | 407-0653-00 | | | | | 1 | | | | | BRACKET, cam switch |
| -64 | 105-0303-00 | | | | | 1 | | | | | DRUM ASSEMBLY |
| -65 | 401-0056-00 | | | | | 1 | | | | | BEARING, rear |
| -66 | 210-0406-00 | | | | | 6 | | | | | NUT, hex., 4-40 x 0.188 inch |
| | - - - - - | | | | | - | | | | | mounting hardware: (not included w/actuator assembly) |
| -67 | 211-0116-00 | | | | | 6 | | | | | SCREW, sems, 4-40 x 0.312 inch, PHB |
| -68 | - - - - - | | | | | 1 | | | | | RESISTOR, variable, w/hardware |
| | - - - - - | | | | | - | | | | | mounting hardware: (not included w/resistor) |
| -69 | 386-2176-00 | | | | | 1 | | | | | PLATE, mounting |
| -70 | 210-0046-00 | | | | | 1 | | | | | WASHER, lock, internal, 0.261 ID x 0.40 inch OD |

¹Replace only with part bearing the same color code as the original part in your instrument.

FIGURE 1 FRONT & CABINET (cont)

| Fig. & Index No. | Tektronix Part No. | Serial/Model No. Eff Disc | Q † y | | | | | Description |
|------------------------|-----------------------|------------------------------|-------------|---|---|---|---|---|
| | | | 1 | 2 | 3 | 4 | 5 | |
| 1-157 | 426-0869-00 | | 1 | | | | | FRAME SECTION, cabinet right |
| | - - - - - | | - | | | | | mounting hardware: (not included w/frame section) |
| -158 | 211-0633-00 | | 4 | | | | | SCREW, 6-32 x 4.50 mm, 100° csk, FHS |
| -159 | 386-1316-00 | | 1 | | | | | SUPPORT, CRT |
| -160 | 179-1792-00 | | 1 | | | | | WIRING HARNESS, CRT |
| | - - - - - | | - | | | | | wiring harness includes: |
| | 136-0266-01 | | 1 | | | | | SOCKET, CRT |
| -161 | 352-0303-00 | | 1 | | | | | HOLDER, angle, circuit board |
| | - - - - - | | - | | | | | mounting hardware: (not included w/holder) |
| -162 | 211-0101-00 | | 1 | | | | | SCREW, 4-40 x 0.25 inch, 100° csk, FHS |

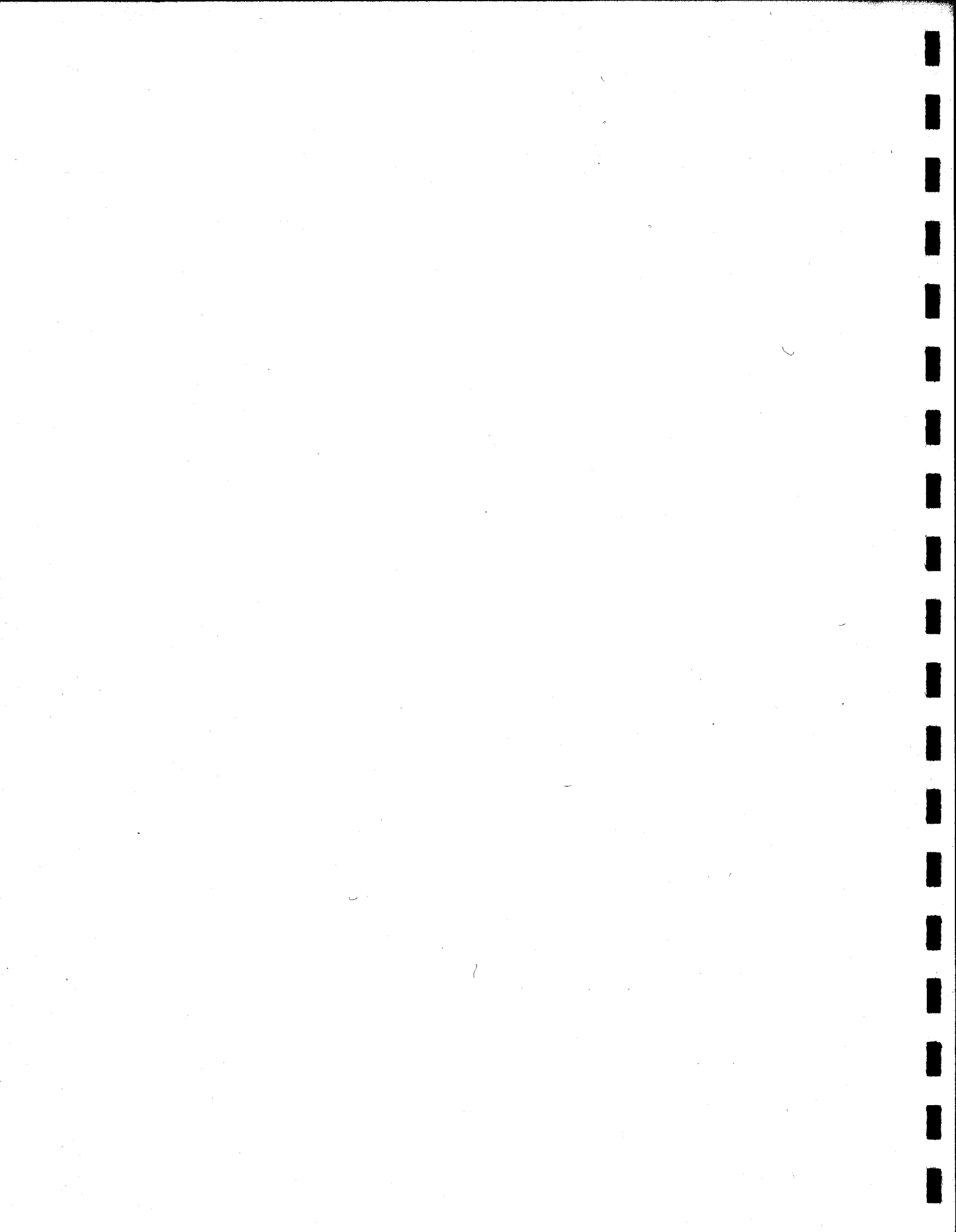

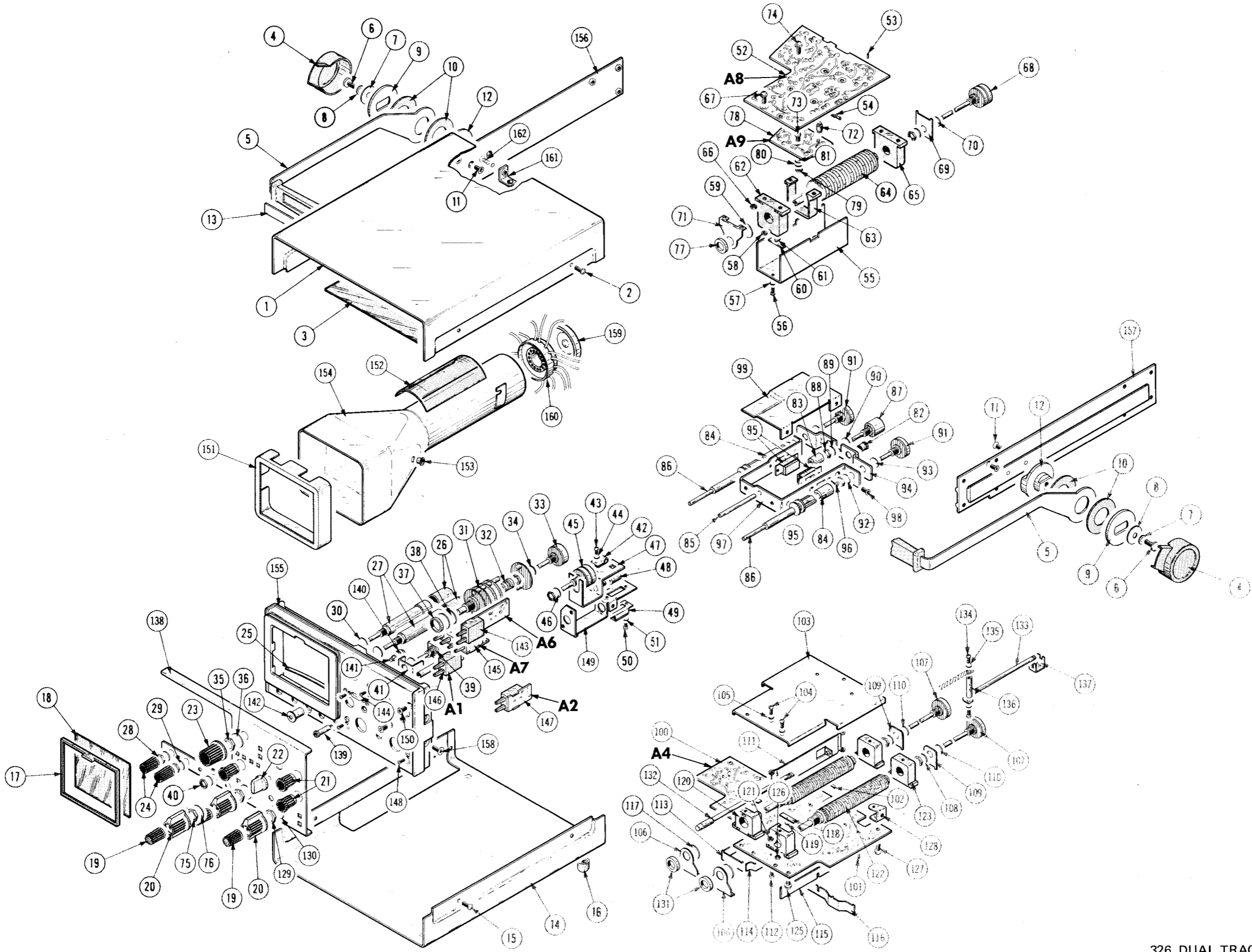

+[ⓐ]

326 DUAL TRACE OSCILLOSCOPE

+

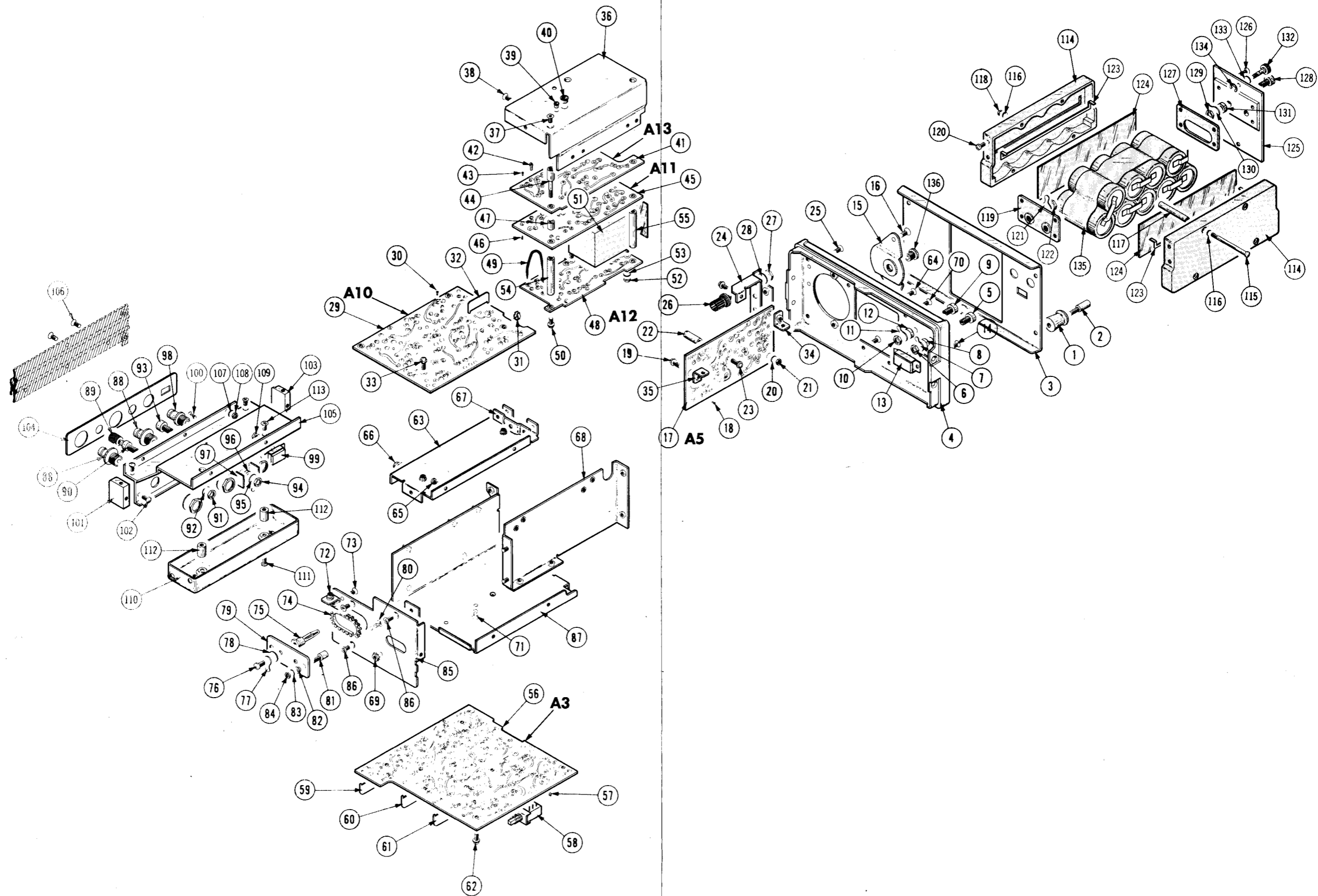

+

FIGURE 2 CHASSIS

| Fig. & Index No. | Tektronix Part No. | Serial/Model No. Eff Disc | Q | | | | | Description |
|------------------------|-----------------------|------------------------------|----|---|---|---|---|--|
| | | | f | y | 1 | 2 | 3 | |
| 2-1 | 348-0296-00 | | 4 | | | | | FOOT, cabinet |
| | - - - - - | | - | | | | | mounting hardware for each: (not included w/foot) |
| -2 | 213-0285-00 | | 1 | | | | | SCREW, foot |
| -3 | 333-1548-00 | | 1 | | | | | PANEL, rear |
| -4 | 386-2178-01 | | 1 | | | | | SUBPANEL, rear |
| -5 | 136-0490-00 | | 1 | | | | | SOCKET, banana jack, red |
| | - - - - - | | - | | | | | mounting hardware: (not included w/socket) |
| -6 | 210-0583-00 | | 1 | | | | | NUT, hex., 0.25-32 x 0.312 inch |
| -7 | 210-0223-00 | | 1 | | | | | TERMINAL, lug, 0.25 inch diameter, SE |
| -8 | 210-0898-00 | | 1 | | | | | WASHER, insulating, red |
| -9 | 136-0491-00 | | 1 | | | | | SOCKET, banana jack, charcoal |
| | - - - - - | | - | | | | | mounting hardware: (not included w/socket) |
| -10 | 210-0583-00 | | 1 | | | | | NUT, hex., 0.25-32 x 0.312 inch |
| -11 | 210-0223-00 | | 1 | | | | | TERMINAL, lug, 0.25 inch diameter, SE |
| -12 | 210-0895-00 | | 1 | | | | | WASHER, insulating, black |
| -13 | 260-1372-00 | | 1 | | | | | SWITCH, slide |
| | - - - - - | | - | | | | | mounting hardware: (not included w/switch) |
| -14 | 211-0101-00 | | 2 | | | | | SCREW, 4-40 x 0.25 inch, 100° csk, FHS |
| -15 | 386-2179-00 | | 1 | | | | | PLATE, subpanel, rear |
| | - - - - - | | - | | | | | mounting hardware: (not included w/plate) |
| -16 | 211-0541-00 | | 2 | | | | | SCREW, 6-32 x 0.25 inch, 100° csk, FHS |
| -17 | - - - - - | | 1 | | | | | CIRCUIT BOARD ASSEMBLY--VERTICAL OUTPUT (See A5 electrical list) |
| | - - - - - | | - | | | | | circuit board assembly includes: |
| -18 | 136-0252-04 | | 39 | | | | | SOCKET, pin connector |
| | - - - - - | | - | | | | | mounting hardware: (not included w/circuit board assembly) |
| -19 | 211-0116-00 | | 3 | | | | | SCREW, sems, 4-40 x 0.312 inch, PHB |
| -20 | 210-0994-00 | | 1 | | | | | WASHER, flat, 0.125 ID x 0.25 inch OD |
| -21 | 210-0406-00 | | 1 | | | | | NUT, hex., 4-40 x 0.188 inch |
| -22 | 129-0357-00 | | 1 | | | | | POST |
| | - - - - - | | - | | | | | mounting hardware: (not included w/post) |
| -23 | 211-0116-00 | | 1 | | | | | SCREW, sems, 4-40 x 0.312 inch, PHB |
| -24 | 407-1040-00 | | 1 | | | | | BRACKET, heatsink |
| | - - - - - | | - | | | | | mounting hardware: (not included w/bracket) |
| -25 | 211-0101-00 | | 2 | | | | | SCREW, 4-40 x 0.25 inch, 100° csk, FHS |

FIGURE 2 CHASSIS (cont)

| Fig. & Index No. | Tektronix Part No. | Serial/Model No. Eff | Disc | Q | | | | | Description | |
|------------------|--------------------|----------------------|------|----|---|---|---|---|-------------|--|
| | | | | t | y | 1 | 2 | 3 | | 4 |
| 2-26 | 214-1354-00 | | | 4 | | | | | | HEATSINK |
| | - - - - - | | | - | | | | | | mounting hardware for each: (not included w/heatsink) |
| -27 | 210-0409-00 | | | 1 | | | | | | NUT, hex., 8-32 x 0.312 inch |
| -28 | 210-0008-00 | | | 1 | | | | | | WASHER, lock, internal, 0.172 ID x 0.331 inch OD |
| -29 | - - - - - | | | 1 | | | | | | CIRCUIT BOARD ASSEMBLY--HORIZONTAL (See A10 electrical list) |
| | - - - - - | | | - | | | | | | circuit board assembly includes: |
| -30 | 136-0252-04 | | | 87 | | | | | | SOCKET, pin connector |
| -31 | 214-0283-00 | | | 2 | | | | | | CONTACT, electrical |
| -32 | 337-1614-00 | | | 1 | | | | | | SHIELD, electrical |
| | - - - - - | | | - | | | | | | mounting hardware: (not included w/circuit board assembly) |
| -33 | 211-0116-00 | | | 3 | | | | | | SCREW, sems, 4-40 x 0.312 inch, PHB |
| -34 | 352-0302-00 | | | 1 | | | | | | HOLDER, angle, circuit board |
| -35 | 352-0301-00 | | | 1 | | | | | | HOLDER, angle, circuit board |
| -36 | 337-1611-00 | | | 1 | | | | | | SHIELD, high voltage |
| | - - - - - | | | - | | | | | | mounting hardware: (not included w/shield) |
| -37 | 211-0105-00 | | | 4 | | | | | | SCREW, 4-40 x 0.188 inch, 100° csk, FHS |
| -38 | 211-0101-00 | | | 4 | | | | | | SCREW, 4-40 x 0.25 inch, 100° csk, FHS |
| -39 | 348-0031-00 | | | 2 | | | | | | GROMMET, plastic, 0.125 inch ID |
| -40 | 348-0055-00 | | | 1 | | | | | | GROMMET, plastic, 0.25 inch diameter |
| | 672-0039-00 | | | 1 | | | | | | CIRCUIT BOARD ASSEMBLY--POWER REGULATOR |
| | - - - - - | | | - | | | | | | circuit board assembly includes: |
| -41 | - - - - - | | | 1 | | | | | | CIRCUIT BOARD ASSEMBLY--CONTROL (See A13 electrical list) |
| | - - - - - | | | - | | | | | | circuit board assembly includes: |
| -42 | 214-0579-00 | | | 1 | | | | | | TERMINAL, test point |
| -43 | 136-0252-04 | | | 46 | | | | | | SOCKET, pin connector |
| | - - - - - | | | - | | | | | | mounting hardware: (not included w/circuit board assembly) |
| -44 | 351-0326-00 | | | 3 | | | | | | GUIDE POST, lock |
| -45 | - - - - - | | | 1 | | | | | | CIRCUIT BOARD ASSEMBLY--RECTIFIER (See A11 electrical list) |
| | - - - - - | | | - | | | | | | circuit board assembly includes: |
| -46 | 136-0252-04 | | | 6 | | | | | | SOCKET, pin connector |
| | 342-0142-00 | | | 1 | | | | | | INSULATOR, mylar |
| -47 | 351-0325-00 | | | 3 | | | | | | GUIDE POST |
| -48 | - - - - - | | | 1 | | | | | | CIRCUIT BOARD ASSEMBLY--REGULATOR (See A12 electrical list) |
| | - - - - - | | | - | | | | | | circuit board assembly includes: |
| -49 | 346-0032-00 | | | 2 | | | | | | STRAP, mouse tail |
| | - - - - - | | | - | | | | | | mounting hardware: (not included w/circuit board assembly) |
| -50 | 211-0116-00 | | | 3 | | | | | | SCREW, sems, 4-40 x 0.312 inch, PHB |

FIGURE 2 CHASSIS (cont)

| Fig. & Index No. | Tektronix Part No. | Serial/Model No. | | Q t y | Description |
|------------------------|-----------------------|------------------|------|-------------|--|
| | | Eff | Disc | | |
| 2-51 | - - - - - | | | 1 | TRANSFORMER |
| | - - - - - | | | - | mounting hardware: (not included w/transformer) |
| -52 | 210-0406-00 | | | 2 | NUT, hex., 4-40 x 0.188 inch |
| -53 | 210-0004-00 | | | 2 | WASHER, lock, internal, 0.12 ID x 0.26 inch OD |
| -54 | 129-0360-00 | | | 1 | POST, plastic |
| -55 | 129-0361-00 | | | 2 | POST |
| -56 | - - - - - | | | - | CIRCUIT BOARD ASSEMBLY--VERTICAL PRE AMP (See A3 electrical list) |
| | - - - - - | | | - | circuit board assembly includes: |
| -57 | 136-0252-04 | | | 111 | SOCKET, pin connector |
| -58 | 260-1132-00 | | | 1 | SWITCH, push-INVERT |
| -59 | 337-1615-00 | | | 1 | SHIELD, electrical |
| -60 | 337-1616-00 | | | 1 | SHIELD, electrical |
| -61 | 337-1617-00 | | | 1 | SHIELD, electrical |
| | - - - - - | | | - | mounting hardware: (not included w/circuit board assembly) |
| -62 | 211-0116-00 | | | 5 | SCREW, sems, 4-40 x 0.312 inch, PHB |
| -63 | 337-1610-00 | | | 1 | SHIELD, battery pack top |
| | - - - - - | | | - | mounting hardware: (not included w/shield) |
| -64 | 211-0101-00 | | | 2 | SCREW, 4-40 x 0.25 inch, 100° csk, FHS |
| -65 | 211-0005-00 | | | 3 | SCREW, 4-40 x 0.125 inch, PHS |
| -66 | 210-0406-00 | | | 3 | NUT, hex., 4-40 x 0.188 inch |
| | 210-0004-00 | | | 3 | WASHER, lock, internal, 0.12 ID x 0.26 inch OD |
| -67 | 407-1053-00 | | | 2 | BRACKET, double angle |
| -68 | 337-1609-00 | | | 1 | SHIELD, electrical |
| | - - - - - | | | - | mounting hardware: (not included w/shield) |
| -69 | 210-0586-00 | | | 2 | NUT, keps, 4-40 x 0.25 inch |
| -70 | 211-0101-00 | | | 2 | SCREW, 4-40 x 0.25 inch, 100° csk, FHS |
| -71 | 211-0105-00 | | | 4 | SCREW, 4-40 x 0.188 inch, 100° csk, FHS |
| -72 | 352-0304-00 | | | 1 | HOLDER, circuit board |
| | - - - - - | | | - | mounting hardware: (not included w/holder) |
| -73 | 211-0105-00 | | | 1 | SCREW, 4-40 x 0.188 inch, 100° csk, FHS |
| -74 | 255-0334-00 | | | in | PLASTIC CHANNEL, 3 inches long |
| -75 | 134-0013-00 | | | 2 | PLUG, tip, banana type |
| | - - - - - | | | - | mounting hardware for each: (not included w/plug) |
| -76 | 211-0510-00 | | | 1 | SCREW, 6-32 x 0.375 inch, PHS |
| -77 | 210-0203-00 | | | 1 | LUG, solder, SE #6 |
| -78 | 210-0811-00 | | | 1 | WASHER, fiber |

FIGURE 2 CHASSIS (cont)

| Fig. & Index No. | Tektronix Part No. | Serial/Model No. | | Q t y | Description |
|------------------------|-----------------------|------------------|------|-------------|---|
| | | Eff | Disc | | |
| 1-79 | 386-2184-00 | | | 1 | PLATE, spacer |
| | - - - - - | | | - | mounting hardware: (not included w/plate) |
| -80 | 211-0105-00 | | | 2 | SCREW, 4-40 x 0.188 inch, 100° csk, FHS |
| -81 | 361-0453-00 | | | 2 | SPACER |
| -82 | 210-0994-00 | | | 2 | WASHER, flat, 0.125 ID x 0.25 inch, OD |
| -83 | 210-0054-00 | | | 2 | WASHER, lock, split, 0.118 ID x 0.212 inch OD |
| -84 | 210-0046-00 | | | 2 | NUT, hex., 4-40 x 0.188 inch |
| -85 | 337-1612-00 | | | 1 | SHIELD, electrical |
| | - - - - - | | | - | mounting hardware: (not included w/shield) |
| -86 | 211-0101-00 | | | 3 | SCREW, 4-40 x 0.25 inch, 100° csk, FHS |
| -87 | 441-1067-00 | | | 1 | CHASSIS, main |
| -88 | 131-0274-00 | | | 2 | CONNECTOR, BNC, insulated, w/hardware |
| | 129-0103-00 | | | 1 | POST, binding |
| | - - - - - | | | - | post includes: |
| -89 | 200-0103-00 | | | 1 | NUT, knurled, 0.25-28 x 0.375 inch OD |
| -90 | 129-0077-00 | | | 1 | POST, binding, 0.25-28 x 0.938 inch long |
| | - - - - - | | | - | mounting hardware: (not included w/post) |
| -91 | 210-0455-00 | | | 1 | NUT, hex., 0.25-28 x 0.375 inch |
| -92 | 210-0223-00 | | | 1 | TERMINAL, lug, 0.25 inch diameter, SE |
| -93 | 136-0491-00 | | | 1 | SOCKET, banana jack, charcoal |
| | - - - - - | | | - | mounting hardware: (not included w/socket) |
| -94 | 210-0465-00 | | | 1 | POST, hex., 0.25-32 x 0.375 inch |
| -95 | 210-0223-00 | | | 1 | TERMINAL, lug, 0.25 inch diameter, SE |
| -96 | 210-0895-00 | | | 1 | WASHER, insulating, black |
| -97 | 337-1635-00 | | | 1 | SHIELD, electrical |
| -98 | 131-0106-00 | | | 1 | CONNECTOR, receptacle, female BNC, w/hardware |
| | - - - - - | | | - | mounting hardware: (not included w/connector) |
| | 210-0255-00 | | | 1 | TERMINAL, lug, 0.391 ID, SE |
| -99 | 260-0905-00 | | | 1 | SWITCH, slide |
| | - - - - - | | | - | mounting hardware: (not included w/switch) |
| -100 | 211-0073-00 | | | 2 | SCREW, 2-56 x 0.218 inch, 82° csk, FHS |
| -101 | 391-0097-00 | | | 1 | BLOCK, input bracket, right |
| | - - - - - | | | - | mounting hardware: (not included w/block) |
| -102 | 211-0079-00 | | | 2 | SCREW, 2-56 x 0.188 inch, PHS |
| -103 | 391-0098-00 | | | 1 | BLOCK, input bracket, left |
| | - - - - - | | | - | mounting hardware: (not included w/block) |
| | 211-0079-00 | | | 2 | SCREW, 2-56 x 0.188 inch, PHS |

FIGURE 2 CHASSIS (cont)

| Fig. & Index No. | Tektronix Part No. | Serial/Model No. | | Q t y | Description |
|------------------------|-----------------------|------------------|------|-------------|--|
| | | Eff | Disc | | |
| 2-104 | 333-1549-00 | | | 1 | PANEL, side |
| -105 | 407-1041-00 | | | 1 | BRACKET, input |
| | - - - - - | | | - | mounting hardware: (not included w/bracket) |
| -106 | 211-0073-00 | | | 3 | SCREW, 2-56 x 0.218 inch, 82° csk, FHS |
| -107 | 210-0001-00 | | | 3 | WASHER, lock, internal, 0.092 ID x 0.18 inch OD |
| -108 | 210-0405-00 | | | 3 | NUT, hex., 4-40 x 0.188 inch |
| -109 | 210-0586-00 | | | 2 | NUT, keps, 4-40 x 0.25 inch |
| -110 | 380-0274-00 | | | 1 | HOUSING, delay line |
| | - - - - - | | | - | mounting hardware: (not included w/housing) |
| -111 | 211-0005-00 | | | 2 | SCREW, 4-40 x 0.125 inch, PHS |
| -112 | 129-0362-00 | | | 2 | POST |
| -113 | 211-0105-00 | | | 2 | SCREW, 4-40 x 0.188 inch, 100° csk, FHS |
| | 016-0296-00 | | | 1 | BATTERY PACK, complete |
| | - - - - - | | | - | battery pack includes: |
| -114 | 343-0349-00 | | | 2 | CLAMP, battery retaining |
| | - - - - - | | | - | mounting hardware: (not included w/clamp) |
| -115 | 211-0194-00 | | | 4 | SCREW, 4-40 x 47.5 mm, PHS |
| -116 | 210-0054-00 | | | 8 | WASHER, lock, split, 0.118 ID x 0.212 inch OD |
| -117 | 129-0358-00 | | | 4 | POST, plastic |
| -118 | 210-0406-00 | | | 4 | NUT, hex., 4-40 x 0.188 inch |
| -119 | 136-0487-00 | | | 1 | SOCKET, banana jack, twin |
| | - - - - - | | | - | mounting hardware: (not included w/socket) |
| -120 | 213-0141-00 | | | 4 | SCREW, thread forming, 4-40 x 0.25 inch, PHS |
| -121 | 210-0223-00 | | | 2 | TERMINAL, lug, 0.25 inch diameter, SE |
| | - - - - - | | | - | mounting hardware for each: (not included w/terminal) |
| -122 | 210-0583-00 | | | 1 | NUT, hex., 0.25-32 x 0.312 inch |
| -123 | 344-0238-00 | | | 2 | CLIP, conductor, battery |
| -124 | 342-0139-00 | | | 2 | INSULATOR, mylar |
| -125 | 333-1550-00 | | | 1 | PANEL, battery pack |
| | - - - - - | | | - | mounting hardware: (not included w/panel) |
| -126 | 211-0025-00 | | | 4 | SCREW, 4-40 x 0.375 inch, 100° csk, FHS |
| | 213-0107-00 | | | 2 | SCREW, thread forming, 4-40 x 0.25 inch, 100° csk, FHS |
| -127 | 386-2180-00 | | | 1 | PLATE, battery pack |
| -128 | 136-0491-00 | | | 1 | SOCKET, banana jack, charcoal |
| | - - - - - | | | - | mounting hardware: (not included w/socket) |
| -129 | 210-0583-00 | | | 1 | NUT, hex., 0.25-32 x 0.312 inch |
| -130 | 210-0223-00 | | | 1 | TERMINAL, lug, 0.25 inch diameter, SE |
| -131 | 210-0895-00 | | | 1 | WASHER, insulating, black |

FIGURE 2 CHASSIS (cont)

| Fig. & Index No. | Tektronix Part No. | Serial/Model No. Eff Disc | Q | | | | | Description | |
|------------------------|-----------------------|------------------------------|---|---|---|---|---|-------------|--|
| | | | t | y | 1 | 2 | 3 | | 4 |
| 2- | 136-0490-00 | | 1 | | | | | | SOCKET, banana jack, red |
| | - - - - - | | - | | | | | | mounting hardware: (not included w/socket) |
| | 210-0583-00 | | 1 | | | | | | NUT, hex., 0.25-32 x 0.312 inch |
| | 210-0223-00 | | 1 | | | | | | TERMINAL, lug, 0.25 inch diameter, SE |
| | 210-0898-00 | | 1 | | | | | | WASHER, insulating, red |
| -132 | 213-0283-00 | | 2 | | | | | | THUMBSCREW |
| | - - - - - | | - | | | | | | mounting hardware for each: (not included w/thumbcrew) |
| -133 | 210-1146-00 | | 1 | | | | | | WASHER, 3.8 mm ID x 7 mm OD |
| -134 | 354-0165-00 | | 1 | | | | | | RING, retaining |
| -135 | 146-0018-00 | | 1 | | | | | | BATTERY SET |
| -136 | 213-0282-00 | | 1 | | | | | | THUMBSCREW |

INCLUDED ACCESSORIES

| | | |
|-------------|---|-------------------------------------|
| 010-6049-01 | 2 | PROBE PACKAGE, P6049A w/accessories |
| 016-0532-00 | 1 | CARRYING CASE |
| 346-0098-00 | 1 | STRAP ASSEMBLY |
| 016-0297-00 | 1 | VIEWING HOOD |
| 426-0871-00 | 1 | FRAME FILTER ASSEMBLY |
| 012-0406-00 | 1 | CABLE ASSEMBLY, external, DC |
| 070-1209-00 | 1 | HANDBOOK, operator's |
| 070-1208-00 | 1 | MANUAL, instruction |

MANUAL CHANGE INFORMATION

At Tektronix, we continually strive to keep up with latest electronic developments by adding circuit and component improvements to our instruments as soon as they are developed and tested.

Sometimes, due to printing and shipping requirements, we can't get these changes immediately into printed manuals. Hence, your manual may contain new change information on following pages.

A single change may affect several sections. Sections of the manual are often printed at different times, so some of the information on the change pages may already be in your manual. Since the change information sheets are carried in the manual until ALL changes are permanently entered, some duplication may occur. If no such change pages appear in this section, your manual is correct as printed.



ELECTRICAL PARTS LIST AND SCHEMATIC CORRECTION

CHANGE TO:

MOD NUMBER

| | | | | | |
|------|-------------|-------------|-------|------|---------|
| C361 | 283-0059-00 | 1 μ F | Cer | 25 V | M14,592 |
| R419 | 315-0100-01 | 10 Ω | 1/4 W | 5% | M14,591 |
| R429 | 315-0100-01 | 10 Ω | 1/4 W | 5% | M14,591 |

ADD:

| | | | | | |
|------|-------------|---------------------|-------|-----|---------|
| C616 | 283-0236-00 | 0.01 μ F | 50 V | 20% | M14,589 |
| C763 | 281-0622-00 | 47 pF | 500 V | 1% | M14,590 |
| L416 | 276-0543-00 | Ferramic Suppressor | | | M14,587 |
| L426 | 276-0543-00 | Ferramic Suppressor | | | M14,587 |

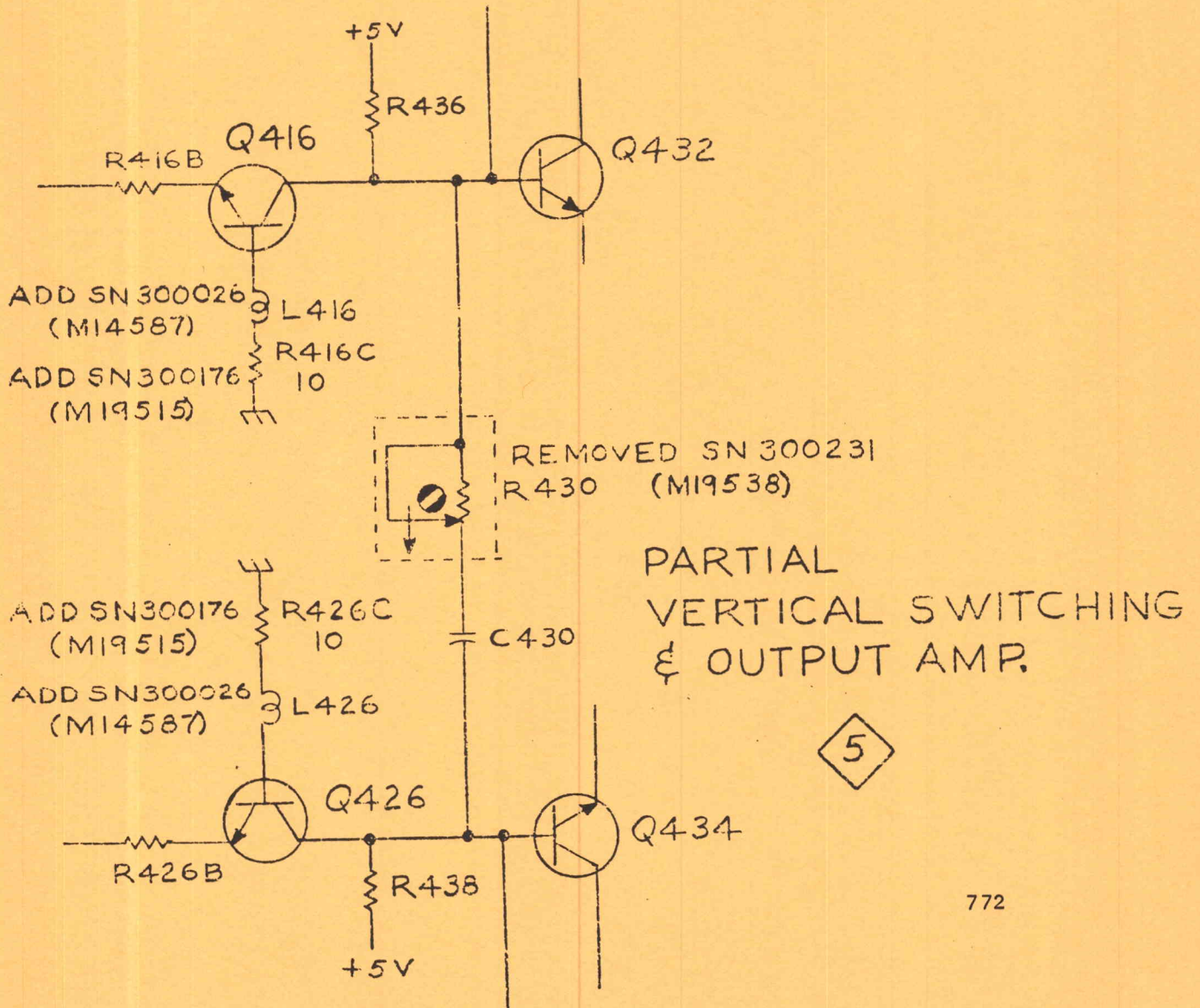

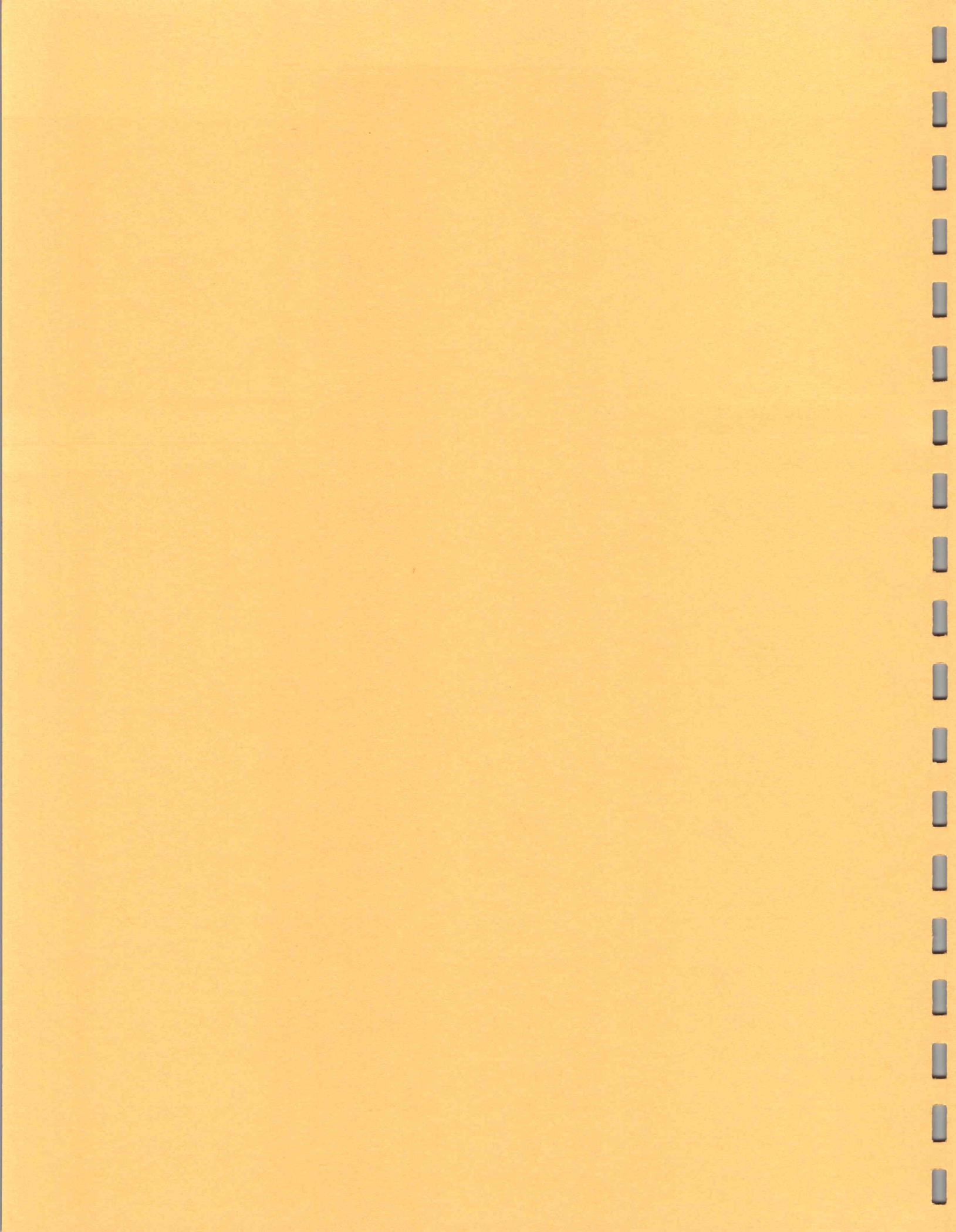

326 EFF SN 300066-up

ELECTRICAL PARTS LIST AND SCHEMATIC CORRECTION

CHANGE TO:

| | | | | |
|-------|-------------|---------------|-------|-------|
| C1123 | 283-0110-00 | 0.005 μ F | Cer | 150 V |
| R1044 | 315-0105-01 | 1 M Ω | 1/4 W | 5% |

M14,588/772
M14,594/772

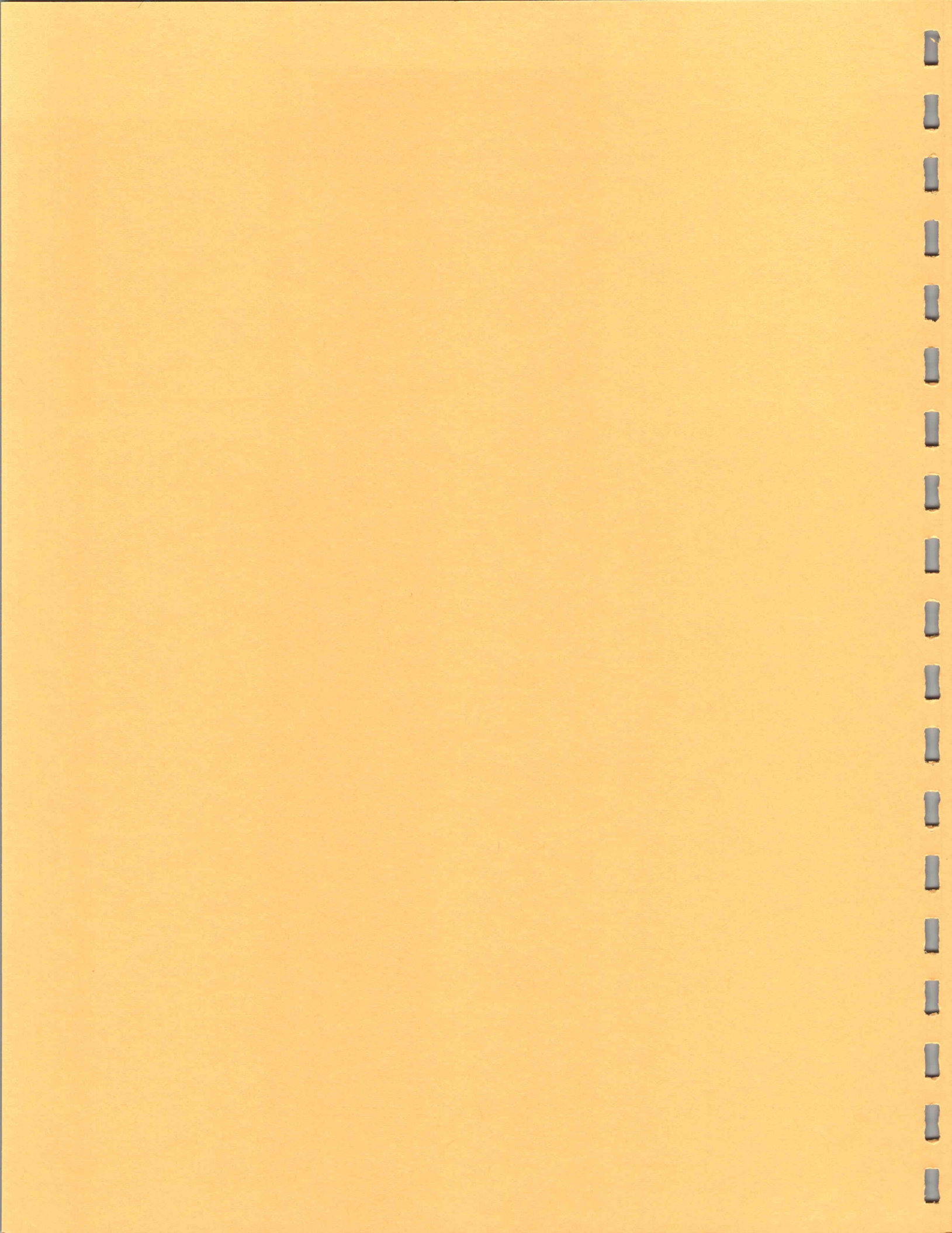

326 EFF SN 300121-up

ELECTRICAL PARTS LIST AND SCHEMATIC CORRECTION

CHANGE TO:

| | | | | | |
|------|-------------|---------------|----------|----|--|
| Q545 | 151-1018-00 | Silicon | 2SK-12-R | | |
| R582 | 321-0289-30 | 10 k Ω | 1/8 W | 1% | |

M14,595/772
M14,596/772

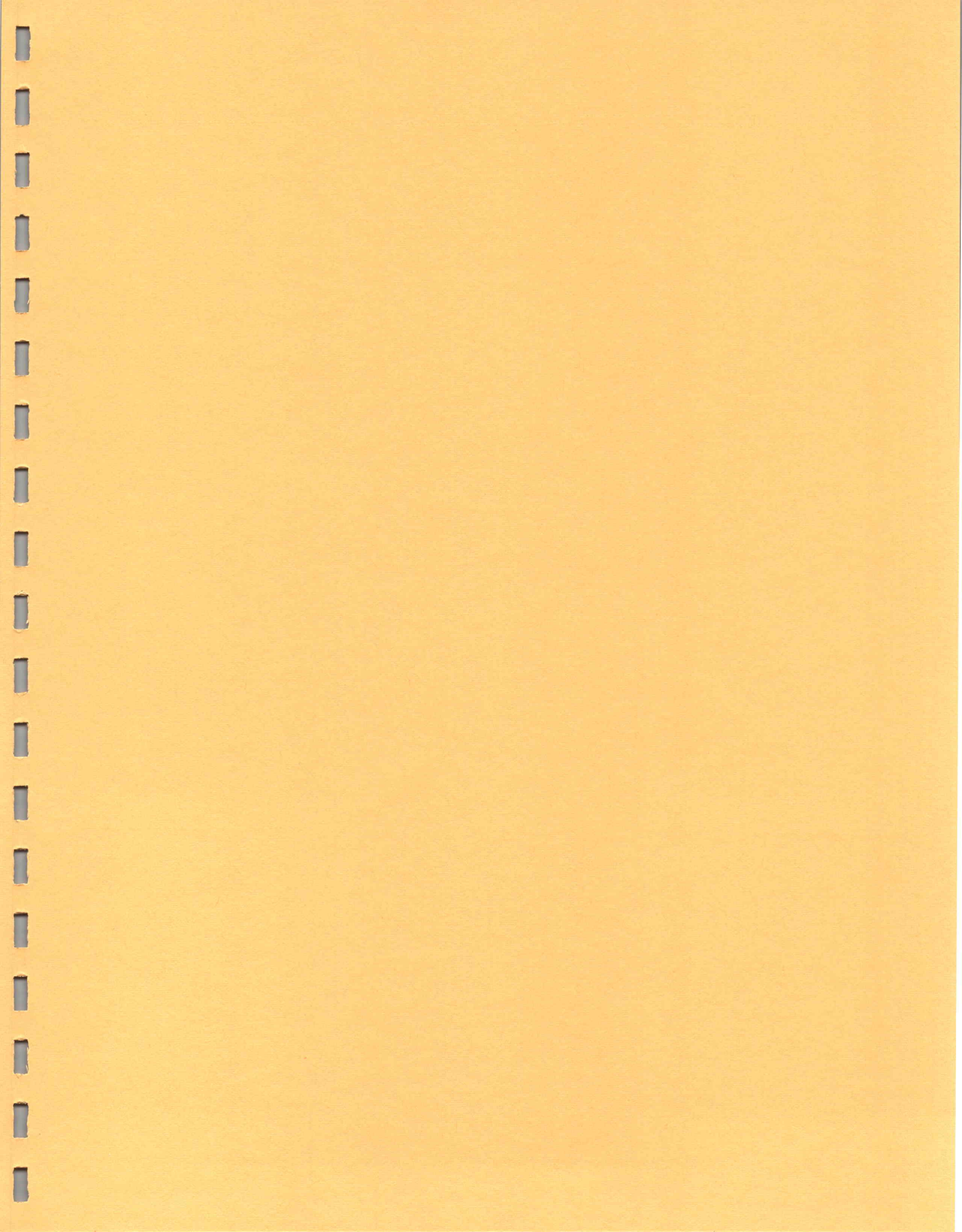

ELECTRICAL PARTS LIST AND SCHEMATIC CORRECTION

CHANGE TO: MOD NUMBER

| | | | |
|------------|-------------|---|---------|
| | 670-1818-01 | Trig/Sweep Board | M19,501 |
| | 670-1819-01 | Timing Board | M19,502 |
| | 670-1820-01 | Power Regulator H.V. Board | M18,503 |
| | 670-1821-01 | Power Regulator Rectifier Board | M18,504 |
| | 670-1822-01 | Power Regulator Control Board | M18,505 |
| | 670-1823-01 | Vert Output Amp Board | M18,506 |
| | 670-1824-01 | Horizontal Board | M18,507 |
| | 670-1825-01 | Vert Preamp Board | M18,508 |
| R706 | 311-0633-00 | 5 k Ω , Var | M19,509 |
| C705 | 283-0231-00 | 470 pF 500 V 10% | M18,510 |
| C611 | 281-0650-00 | 18 pF 200 V 10% | M18,511 |
| ADD: | | | |
| TP1051 | 214-0579-00 | Terminal Test Point | M19,513 |
| R1049 | 321-0193-30 | 1 k Ω 1/8 W 1% | M19,514 |
| R416C | 315-0100-01 | 10 Ω 1/4 W 5% | M19,515 |
| R426C | 315-0100-01 | 10 Ω 1/4 W 5% | M19,515 |
| CHANGE TO: | | | |
| L990 | 108-0587-00 | 5.6 mH | M19,523 |
| R622A (B) | 311-1330-01 | Dual, 20 k Ω x 50 k Ω , Var w/screw & detent | M19,525 |
| D760 | 152-0217-00 | Zener 1N756A 0.4W 8.2 V \pm 4.5% | M19,526 |
| R760 | 315-0474-01 | 470 k Ω 1/4 W 5% | M19,526 |
| D966 | 152-0185-00 | Silicon Replaceable by 1N4152 | M19,527 |
| R650 | 315-0511-01 | 510 Ω 1/4 W 5% | M19,530 |

ELECTRICAL PARTS LIST AND SCHEMATIC CORRECTION

REMOVE:

MOD NUMBER

| | | | | | |
|------|-------------|--------|-------|---------|---------|
| C635 | 283-0224-00 | 5 pF | 50 V | ±0.5 pF | M19,531 |
| R635 | 315-0752-01 | 7.5 kΩ | 1/4 W | 5% | M19,531 |
| D638 | 152-0327-00 | BAX13 | | | M19,532 |
| D639 | 152-0516-00 | 1N5297 | | | M19,532 |

CHANGE TO:

| | | | | | |
|-------|-------------|--------|-------|----|---------|
| R639A | 315-0332-02 | 3.3 kΩ | 1/4 W | 5% | M19,532 |
| D628 | 152-0327-00 | BAX13 | | | M19,540 |

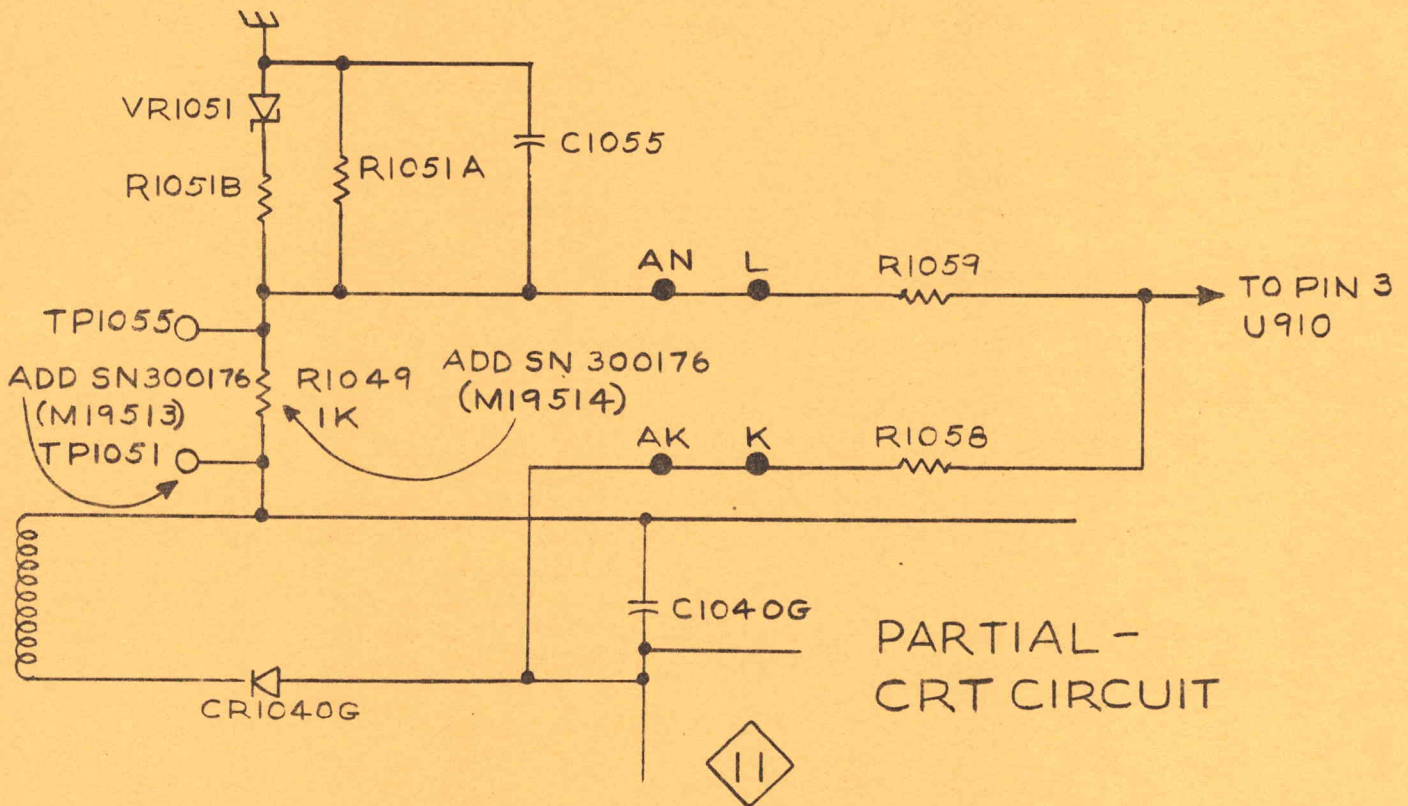

SCHEMATIC CORRECTION

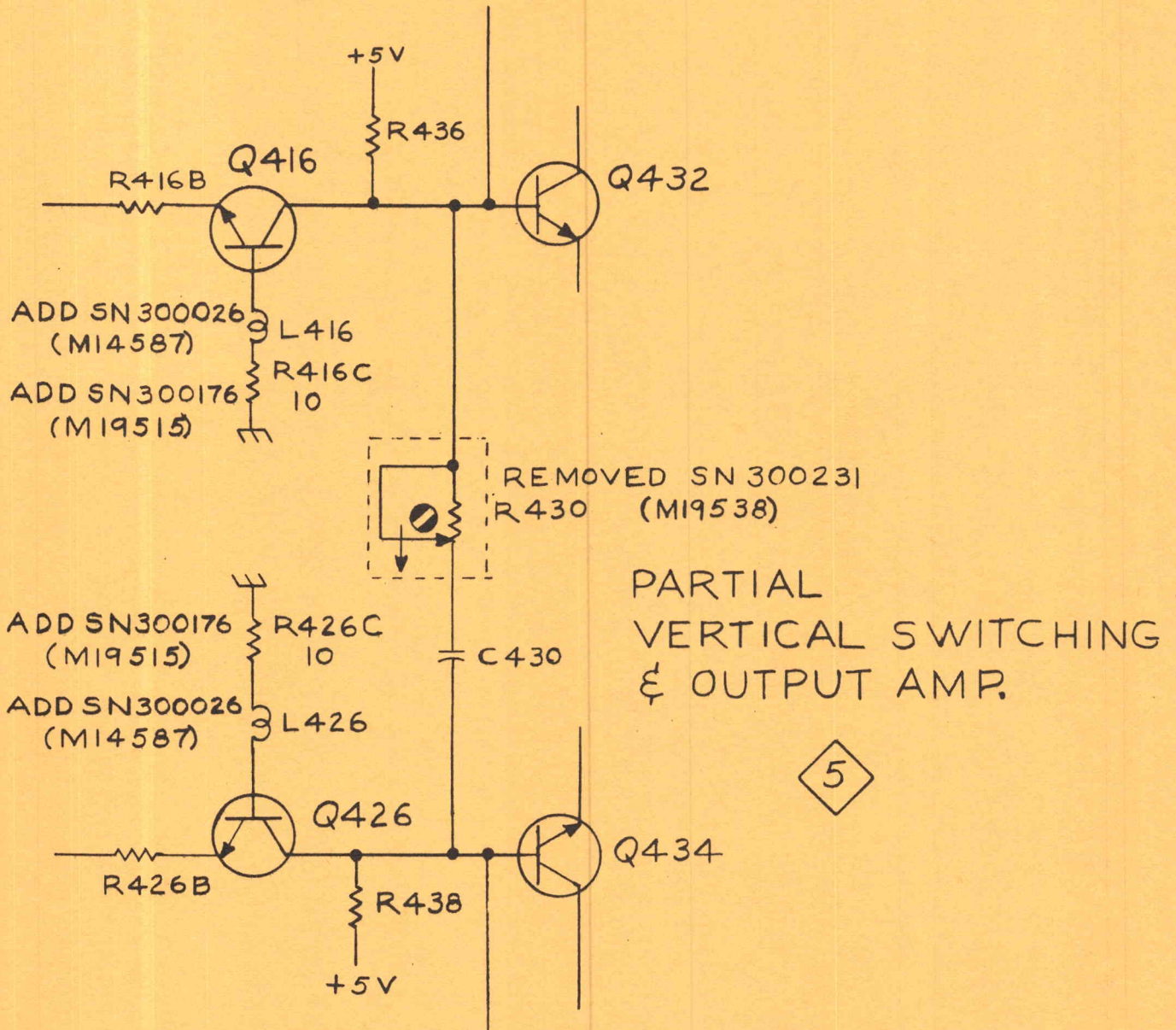

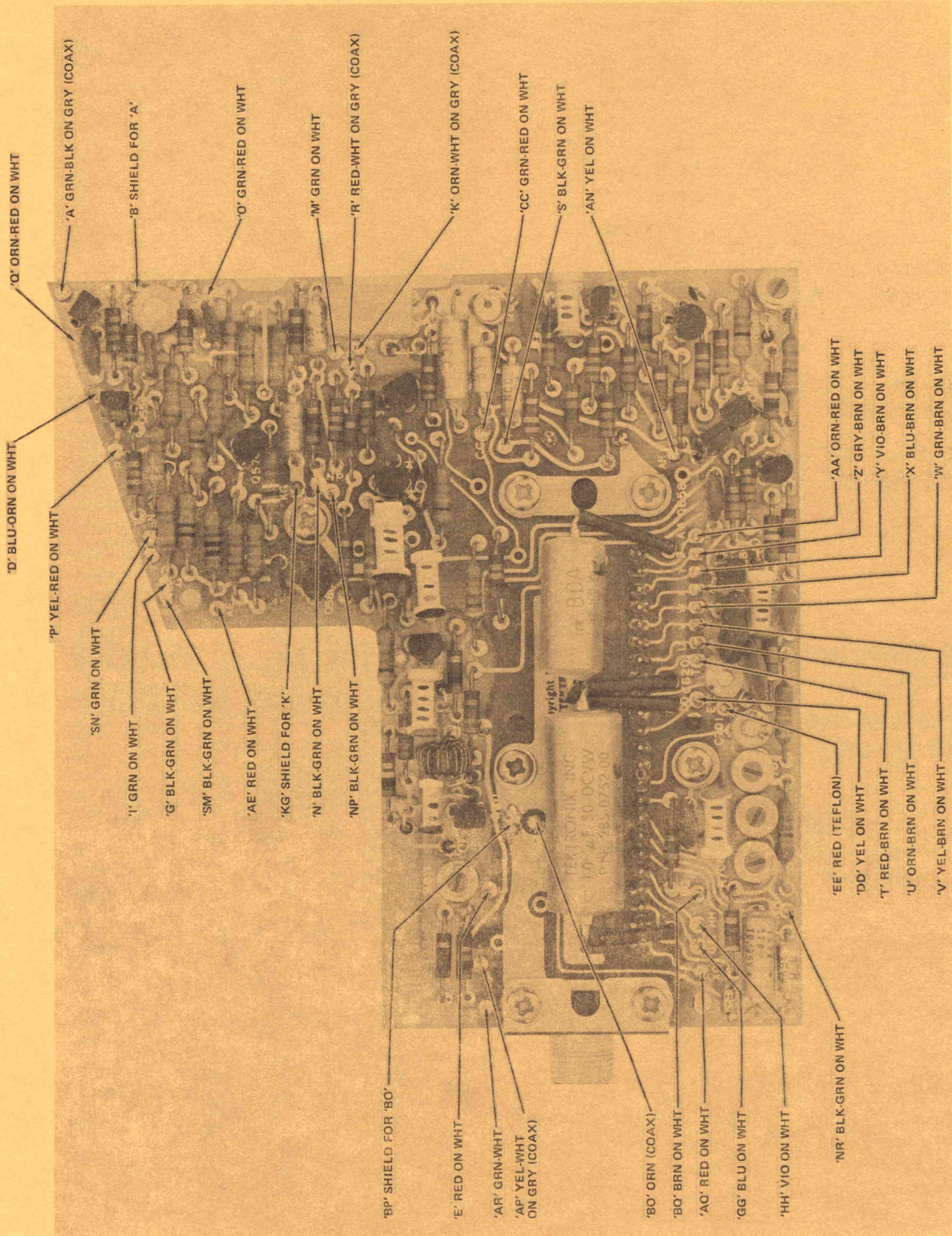

A8. Trigger-Sweep

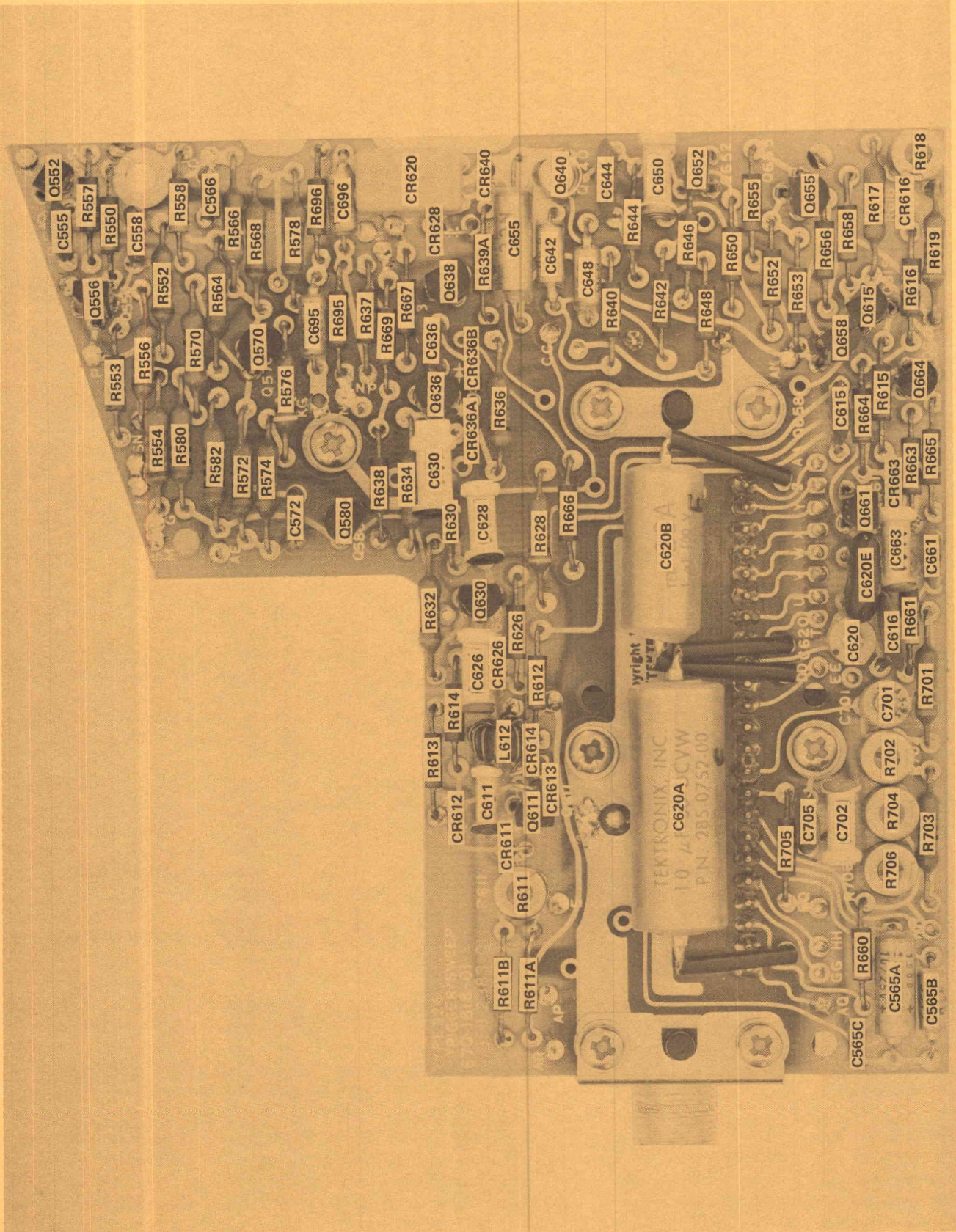

A8. Trigger-Sweep

ELECTRICAL PARTS LIST AND SCHEMATIC CORRECTION

| CHANGE TO: | | | | MOD NUMBER |
|------------|-------------|--|----------|------------|
| R66 | 311-1329-01 | 3 k Ω , Var w/screw & detent | | M19,500 |
| R266 | 311-1329-01 | 3 k Ω , Var w/screw & detent | | M19,500 |
| C1000 | 290-0643-00 | 470 μ F Tantalum | 10V 20% | M19,512 |
| C1016 | 290-0643-00 | 470 μ F Tantalum | 10 V 20% | M19,512 |
| C764 | 283-0079-02 | 0.01 μ F Cer | 250V 20% | M19,516 |
| C679 | 283-0079-02 | 0.01 μ F Cer | 250V 20% | M19,517 |
| ADD: | | | | |
| C887 | 283-0203-00 | 0.47 μ F Cer | 50V 20% | M19,534 |
| CHANGE TO: | | | | |
| C21 | 281-0193-00 | 2-8 pF, Var | | M19,537 |
| C221 | 281-0193-00 | 2-8 pF, Var | | M19,537 |
| C28B | 281-0194-00 | 2-8 pF, Var | | M19,537 |
| C228B | 281-0194-00 | 2-8 pF, Var | | M19,537 |
| C27B | 281-0195-00 | 5.5-18 pF, Var | | M19,537 |
| C227B | 281-0195-00 | 5.5-18 pF, Var | | M19,537 |
| C28A | 281-0195-00 | 5.5-18 pF, Var | | M19,537 |
| C228A | 281-0195-00 | 5.5-18 pF, Var | | M19,537 |
| REMOVE: | | | | |
| R430 | 311-0607-00 | 10 k Ω , Var | | M19,538 |

SCHEMATIC CORRECTION

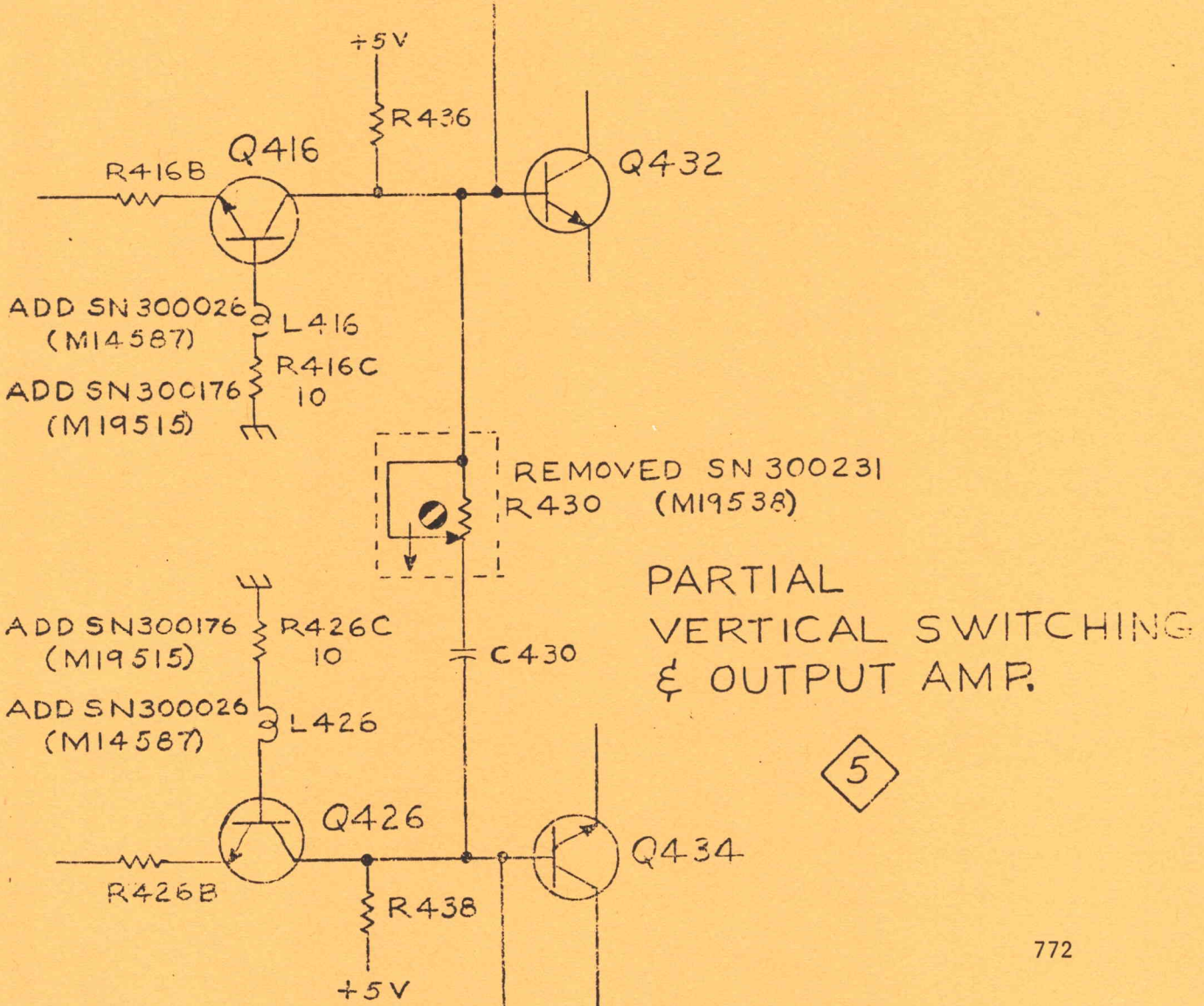
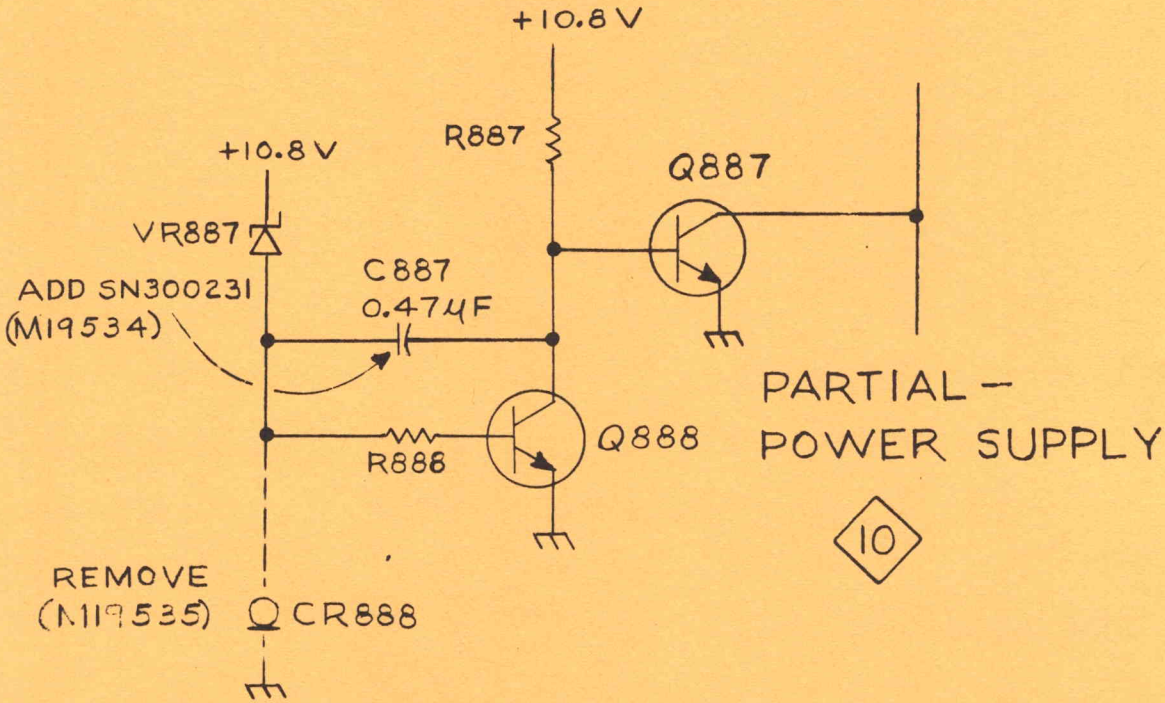

ELECTRICAL PARTS LIST AND SCHEMATIC CORRECTION

CHANGE TO:

| | | | | | |
|------|-------------|-----------------|-------|-------|-----|
| C460 | 283-0329-00 | 0.39 pF | Cer | 500 V | 10% |
| C470 | 283-0329-00 | 0.39 pF | Cer | 500 V | 10% |
| Q415 | 151-0216-00 | | | | |
| Q425 | 151-0216-00 | | | | |
| R77 | 321-0297-30 | 12.1 k Ω | 1/8 W | 1% | |
| R79 | 321-0297-30 | 12.1 k Ω | 1/8 W | 1% | |
| R277 | 321-0297-30 | 12.1 k Ω | 1/8 W | 1% | |
| R279 | 321-0297-30 | 12.1 k Ω | 1/8 W | 1% | |
| R370 | 321-0232-30 | 2.55 k Ω | 1/8 W | 1% | |
| R380 | 321-0232-30 | 2.55 k Ω | 1/8 W | 1% | |
| R412 | 321-0229-30 | 2.37 k Ω | 1/8 W | 1% | |
| R422 | 321-0229-30 | 2.37 k Ω | 1/8 W | 1% | |

