

# INSTRUCTION MANUAL

Serial Number 12340

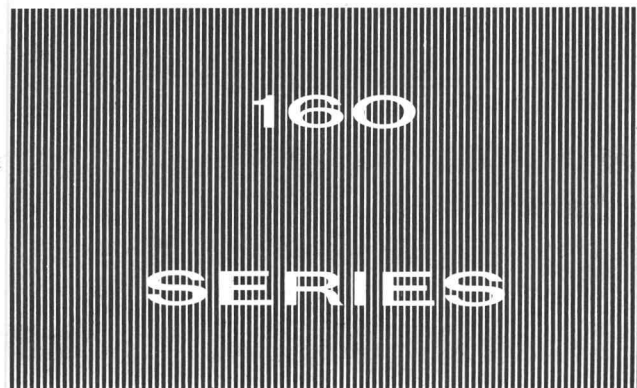

*Tektronix, Inc.*

S.W. Millikan Way ● P. O. Box 500 ● Beaverton, Oregon 97005 ● Phone 644-0161 ● Cables: Tektronix  
070-0220-01



## WARRANTY

All Tektronix instruments are warranted against defective materials and workmanship for one year. Tektronix transformers, manufactured in our own plant, are warranted for the life of the instrument.

Any questions with respect to the warranty mentioned above should be taken up with your Tektronix Field Engineer.

Tektronix repair and replacement-part service is geared directly to the field, therefore all requests for repairs and replacement parts should be directed to the Tektronix Field Office or Representative in your area. This procedure will assure you the fastest possible service. Please include the instrument Type and Serial number with all requests for parts or service.

Specifications and price change privileges reserved.

Copyright © 1960, new material copyright 1968 by Tektronix, Inc., Beaverton, Oregon. Printed in the United States of America. All rights reserved. Contents of this publication may not be reproduced in any form without permission of the copyright owner.



## **CONTENTS**

- Section 1      Specifications
- Section 2      Operating Instructions
- Section 3      Circuit Description
- Section 4      Maintenance
- Abbreviations and Symbols
- Parts Ordering Information
- Section 5      Electrical Parts List
- Section 6      Mechanical Parts List
- Diagrams
- Mechanical Parts List Illustrations

Abbreviations and symbols used in this manual are based on or taken directly from IEEE Standard 260 "Standard Symbols for Units", MIL-STD-12B and other standards of the electronics industry. Change information, if any, is located at the rear of this manual.

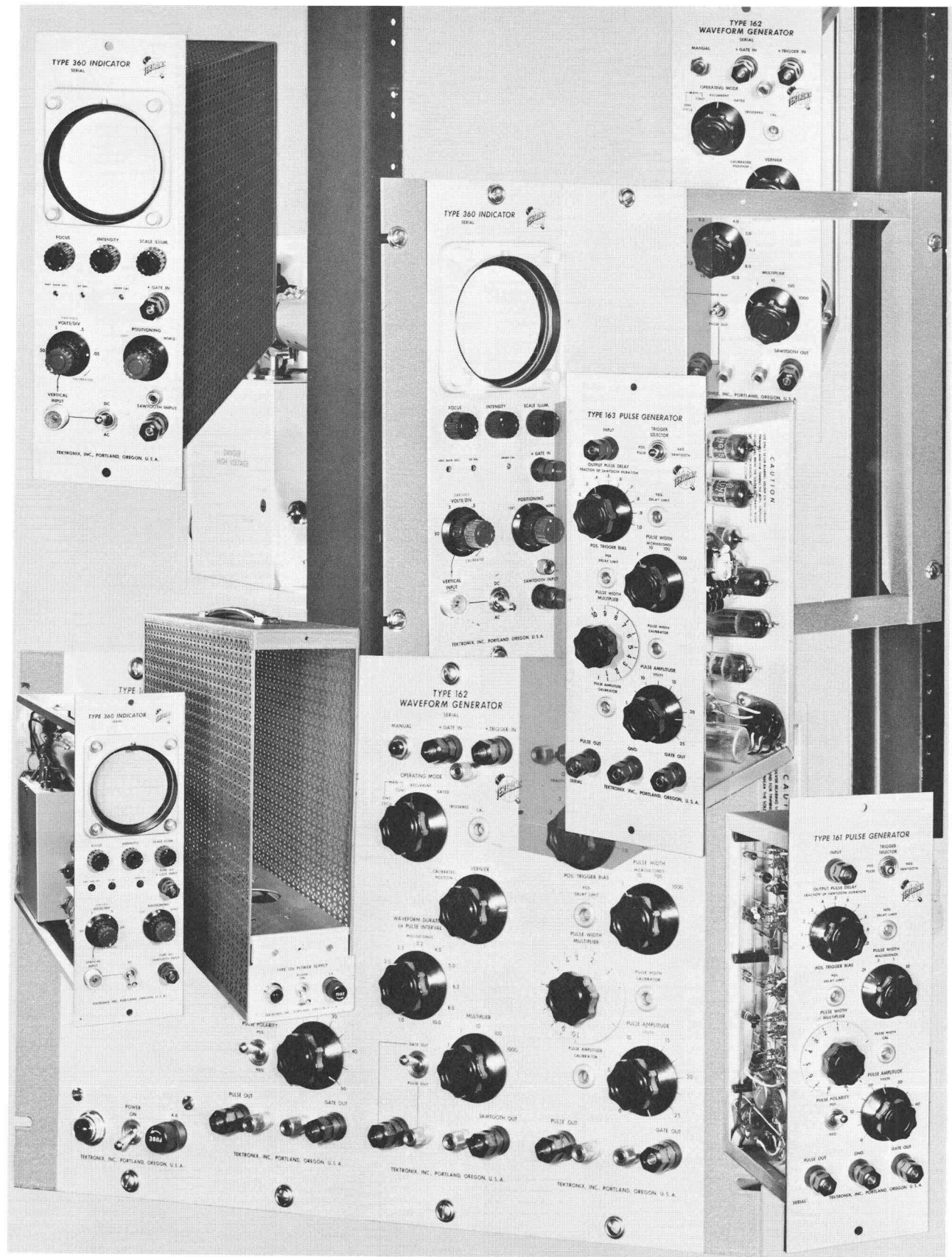

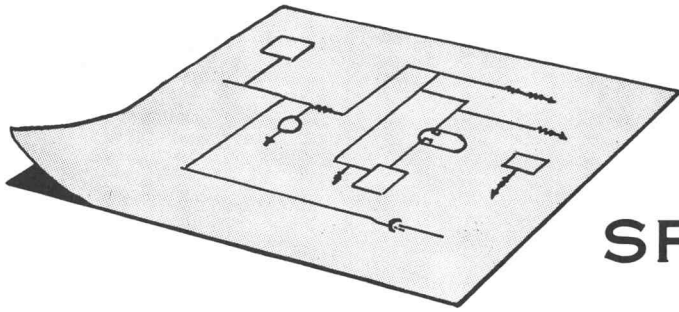

## SECTION 1

# SPECIFICATIONS

### GENERAL DESCRIPTION

The Tektronix 160-Series instruments are designed to supply timed pulses of adjustable amplitude and duration. A choice of power supplies is available as well as an indicator unit. The instruments may be mounted in any combination desired, and an adapter frame, the FA 160 is available for mounting in a standard 19-inch relay-rack.

#### Type 360

The Tektronix Type 360 Indicator contains a 3WP flat-faced crt, high-voltage supply, dc unblanking, vertical amplifier of 0.05 v/div sensitivity, and a horizontal amplifier with a gain of approximately two. It is designed to be powered by a Type 160, Type 160A, or Type 126 Power Supply and to receive its sweep and unblanking voltages from a Type 162 Waveform Generator; it can, however, be operated from any source of the proper voltages and waveforms. Several Type 360 Indicators can be driven by a single Type 162, and a simple Type 161-Type 162 hookup provides calibrated sweep delay. For low-level applications a Tektronix Type 122 Preamplifier provides increased ac sensitivity to 50-microvolts/div. A single Type 160 or Type 160A Power Supply can furnish the power to operate several combinations of the Type 160 Series instruments and Type 360 Indicators.

#### Type 126

The Tektronix Type 126 Power Supply provides the voltages and currents necessary to power one Type 360 Indicator or any one of the 160-Series Waveform Generators. It mounts beneath the unit to be powered, and includes a cabinet

to house both the Type 126 and the unit powered.

#### Type 160 and Type 160A

The Tektronix Type 160 and Type 160A power supplies are designed to furnish current for the instruments composing the 160-Series. Either instrument will mount in the Type FA 160 adapter frame beside a combination of Pulse Generators.

The Type 160A can safely supply six 161's or six 162's. This is due to the internal shunt resistor incorporated in these units which permits 170 ma to be safely drawn from the supply. If you wish to use the Type 160A to supply some other device, however, only 125 ma may safely be drawn from the supply. To exceed this rating you must provide an external shunt resistor for the 225-volt supply.

#### Type 161

The Tektronix Type 161 Pulse Generator is designed to supply calibrated rectangular output pulses of adjustable duration and amplitude and of either polarity when the required trigger voltage is received from an external source. Two types of trigger waveforms can be used to trigger the Type 161, a negative-going sawtooth or a positive pulse. One output pulse is generated for each input pulse or each cycle of the sawtooth.

When a negative sawtooth waveform is used to trigger the generator a rectangular pulse of either polarity and a 50-volt positive gating pulse are generated. The time of occurrence of the pulse and of the gate can be adjusted to any point throughout the duration of the sawtooth. The duration of the generated pulse and the output gate are the same.

When a positive pulse is used to trigger the generator, the same output waveforms are available, but there is no delay available in the generation of the pulse.

### **Type 162**

The Tektronix Type 162 Waveform Generator provides three types of waveforms of adjustable duration and repetition rate: pulse, gate, and sawtooth. Generation of the waveforms can be initiated either by means of an externally derived electrical impulse, or by means of front-panel controls and switches. Pulse and gate waveforms have a minimum risetime of the order of one microsecond and an amplitude of 50 volts. The shortest pulse duration is of the order of 10 microseconds. The sawtooth waveform is a positive voltage decreasing uniformly from positive 150 volts to positive 20 volts.

The device is useful for initiating chains of events electrically, and for controlling the duration of their occurrence and their repetition rate. When generating waveforms recurrently, the instrument provides an unusually stable repetition rate. The Type 162 is specifically designed to operate in conjunction with Tektronix Type 161 Generators.

### **Type 163**

The Tektronix Type 163 Pulse Generator is designed to supply rectangular output pulses of adjustable duration and amplitude when the required trigger voltage is received from an external source.

Two types of triggering waveforms can trigger the Type 163 Pulse Generator, a negative-going sawtooth or a positive pulse. One output pulse is generated for each input pulse or for each cycle of the input sawtooth.

The gate output pulse is taken from the cathode of a cathode follower and the adjustable pulse is taken from a potentiometer comprising the cathode resistor of this cathode follower. The duration of the adjustable pulse and the gate pulse are therefore the same.

The time of occurrence of the output pulse and gate can be adjusted to any point throughout the duration of the triggering sawtooth.

## **PULSE GENERATOR**

### **Output Waveform**

#### Type 161

Positive Gate. Positive Pulse. Negative Pulse.

#### Type 162

Positive Pulse. Positive Gate. Negative-going Sawtooth.

#### Type 163

Positive Gate. Positive Pulse.

### **Positive Pulse Characteristics**

#### Type 161

Amplitude, 0 to 50 volts, continuously variable.

Duration, 10  $\mu$ sec to 0.1 sec continuously variable.

Risetime, .5  $\mu$ sec or better when load capacitance is 10  $\mu$ f or less.

Overshoot, less than 5%.

Delay, 0 to 100% of duration of input sawtooth.

#### Type 162

Amplitude,  $\geq$  50 volts positive from ground.

Duration, 10  $\mu$ sec, to 0.03 sec.

Risetime, 1  $\mu$ sec, approximately, minimum.

Repetition rate,  $\leq$  0.1 cps to  $\geq$  10 kc for recurrent operation.

#### Type 163

Amplitude; continuously adjustable between 0 and 25 volts, peak to peak. Other characteristics, same as gate.

## Negative Pulse Characteristics

Type 161

Similar to positive pulse, except polarity.

## Gate Characteristics

Type 161

Amplitude, 50 volts positive from ground potential, not adjustable.

Type 162

Amplitude,  $\geq 50$  volts positive from ground.

Duration,  $\leq 100 \mu\text{sec}$  to  $\geq 10 \text{ sec}$ .

Repetition rate,  $\leq 0.1 \text{ cps}$  to  $\geq 10 \text{ kc}$  for recurrent operation.

Type 163

Amplitude, fixed, 25 volts, peak to peak.

Duration,  $1 \mu\text{sec}$  to  $10,000 \mu\text{sec}$ , continuously adjustable.

Risetime,  $.2 \mu\text{sec}$  or better when load capacitance is  $10 \mu\mu\text{f}$  or less.

Decay Time,  $0.2$  to  $0.5 \mu\text{sec}$ .

Overshoot can be adjusted to zero.

Delay,  $0$  to  $100$  per cent of sawtooth duration.

## Sawtooth Characteristics

Type 162

Amplitude, Negative going from  $\geq +148$  volts to  $\leq +22$  volts.

Duration,  $\leq 100 \mu\text{sec}$  to  $\geq 10 \text{ sec}$ .

Repetition rate,  $\leq 0.1 \text{ cps}$  to  $\geq 10 \text{ kc}$  for recurrent operation.

## Output Impedance

Type 161

Positive pulse, 1800 ohms maximum.  
Negative pulse, 5000 ohms maximum.  
Positive gate, 1000 ohms maximum.

Type 162

Approximately 1000 ohms for all outputs.

Type 163

Gate, 100 ohms.

Pulse, 500 ohms (varies with pulse-amplitude control setting).

Minimum load resistance 3.5 k.

## Method of Triggering

Type 161

Positive pulse, or negative-going positive sawtooth.

Type 162

Externally derived electrical pulse or gate.  
Front-panel pushbutton or switch.

## Triggering Input Impedance

Type 162

High impedance, consisting of control grid with 1-megohm grid return resistor.

## Trigger Sensitivity

Type 161

Positive pulse, 3-volts peak-to-peak, minimum.

Maximum repetition rate 50 kc.

Type 162

Positive pulse, 15 volts peak or greater with rise time 5 milliseconds or less.

Sine wave, 6 volts rms, frequency between 5 cps and 50 kc. At frequencies below 5 cps, the product of rms voltage times frequency must exceed 10.

### Type 163

Positive pulse, 2 volts peak-to-peak, minimum.

Negative-going sawtooth. Must include dc bias sufficient to keep voltage positive.

## Gate Sensitivity

### Type 162

Eight volts, minimum

## Power Requirements

### Type 161

225 volts dc positive at 22 ma.  
170 volts dc negative at 17 ma.  
6.3 volts ac or dc at 1.65 amps.  
1.1 amp to S/N 135.

### Type 162

225 volts dc positive at 28 ma.  
150 volts dc positive at 1 ma.  
170 volts dc negative at 7 ma.  
6.3 volts ac at 1.7 amps, through male octal socket at rear of instrument.

(TEKTRONIX Type 160A Power Supply is specially designed to furnish the required power for as many as seven of these units.)

### Type 163

-170 volts at 26 ma.

+225 volts at 35 to 45 ma (minimum to maximum pulse duty cycle).

Five Type 163 units can be operated at once from a Type 160A Power Supply.

## POWER SUPPLY

### Voltage and Current Outputs

#### Type 160

+300 volts dc, unregulated, at 170 milliamps\*.

+225 volts, dc, regulated, at 125 milliamps.  
+150 volts dc, regulated, at 5 milliamps.  
-170 volts dc, regulated at 125 milliamps.  
6.3 volts ac, unregulated, at 10 amps.

\*current limitation of the winding in absence of any current through +225-volt regulated circuit.

#### Type 160A

+300 volts dc, unregulated, at 250 milliamps.\*

+225 volts dc, regulated, at 175 milliamps.\*\*

+150 volts dc, regulated at 15 milliamps.  
+70 volts dc, unregulated. \*  
-170 volts dc, regulated, at 125 milliamps.  
6.3 volts ac, unregulated, at 20 amps.

\* Voltage varies with load.

\*\* Will regulate at 225 ma with a 1500-ohm shunt across the 225-volt series tube.

#### Type 126

+300 volts dc, unregulated at 65 milliamps.\*  
+225 volts, dc, regulated at 45 milliamps.  
+150 volts, dc regulated at 5 milliamps.  
-170 volts dc, regulated at 30 milliamps.  
6.3 volts ac, unregulated at 4 amps.

\* In the absence of any current drawn from the 225-volt supply.

## Regulation

### Type 160

Electronic, with Type 5651 gas diode reference element.

### Type 160A

Electronic regulation compensates for line-voltage variations between 105 and 125 volts, and for current-demand differences of the units connected to the power supply.

### Type 126

Electronic regulation compensates for line-voltage variations between 105 and 125



volts, and for current differences of the units connected to the power supply.

Vertical

DC to 500 KC.

Horizontal

DC to 100 kc.

## Ripple

Type 160A

At rated load the ripple is about 40 millivolts at the +225-volt supply, 25 millivolts at the -170-volt supply and 8 millivolts in the +150-volt supply.

Type 126

At rated load the ripple is about 40 millivolts on the +225-volt supply, 30 millivolts on the +150-volt supply, and 10 millivolts on the -170-volt supply.

## Calibrated Sensitivities

Vertical

0.05, 0.5, 5, and 50 volts/division (Continuously variable sensitivity between calibrated steps.)

## Maximum Input Voltage

Vertical

600 v (dc plus peak ac).

## INDICATOR

### Input Impedance

Vertical

Direct, 1 megohm shunted by 40  $\mu\mu\text{f}$ .  
Probe, 10 megohm shunted by 14  $\mu\mu\text{f}$ .

### Waveforms Required

Horizontal

Positive- or negative-going sawtooth, 110 to 150 volts excursion within the limits of -95 volts to +170 volts.

### Frequency Response

Gate, 45 to 75 volts positive same duration as the sawtooth.

## Type 360

### Functions of Controls and Connectors

FOCUS	Adjustable voltage for the crt focusing grid.
INTENSITY	Bias adjustment for crt control grid.
SCALE ILLUM	Adjustable resistor to control the voltage across the graticule lights.
VERT GAIN ADJ.	Screwdriver front-panel control to calibrate the VOLTS/DIV control.
DC BAL	Screwdriver front-panel control to adjust the dc levels so the trace does not shift position vertically when the VARIABLE control is rotated.
SWEEP CAL	Screwdriver front-panel control to adjust the sweep to match the ruled graticule.
+GATE INPUT	Binding post input to crt unblanking circuit.

VOLTS/DIV	Switch to select fixed frequency-compensated attenuators which produce the sensitivity indicated when the VARIABLE control is in the CALIBRATED position.
VARIABLE	Variable gain control with about a 10 to 1 range.
POSITIONING VERT (red)	Control to position the trace vertically.
HORIZ (black)	Control to position the trace horizontally.
VERTICAL INPUT	UHF coax connector to vertical amplifier.
AC-DC	Switch to insert or remove coupling capacitor for ac- or dc-coupled operation.
SAWTOOTH INPUT	Binding post input to horizontal amplifier.

**Type 161**  
**Functions of Controls and Connectors**

INPUT	Connector to TRIGGER SELECTOR switch for connecting external trigger source. (For example, TEKTRONIX Type 162 Waveform Generator.)
TRIGGER SELECTOR	Two-position toggle switch to accommodate input circuit to POS. PULSE input or NEG. SAWTOOTH input.
OUTPUT PULSE DELAY	Variable potentiometer to adjust comparison voltage in sawtooth comparator circuit. Triggers when the two are equal.
POS. TRIGGER BIAS	Same variable potentiometer as above, adjusts operating bias of pulse amplifier for most satisfactory triggering.
NEG. DELAY LIMIT	Screwdriver-adjustable resistor in series with negative end of OUTPUT PULSE DELAY potentiometer, for adjusting low voltage triggering level of voltage comparator circuit to accommodate scale calibrations to various sawtooth amplitudes.
POS. DELAY LIMIT	Screwdriver-adjustable resistor in series with positive end of OUTPUT PULSE DELAY potentiometer, for adjusting high voltage triggering level of voltage comparator circuit to accommodate scale calibration to various sawtooth amplitudes.
PULSE WIDTH	Four-position switch selects value of coupling capacitor in pulse-generating multivibrator, determines discharge time in conjunction with PULSE WIDTH MULTIPLIER variable resistor, and thereby determines pulse width.
PULSE WIDTH MULTIPLIER	Continuously-variable resistor in coupling circuit of pulse-generating multivibrator, determines discharge time in conjunction with PULSE WIDTH adjustable capacitor, and thereby determines pulse width.

PULSE WIDTH CALIBRATOR	Screwdriver adjustable voltage-pickoff potentiometer, adjusts positive bias on pulse-generator multivibrator to accommodate PULSE WIDTH calibrations to characteristics of multivibrator tube. May require readjustment when multivibrator tube is replaced.
PULSE AMPLITUDE	Voltage-pickoff variable potentiometer with contact arm connected to PULSE OUT terminal, determines percentage of developed pulse that is made available to output terminal. Calibrated in volts.
PULSE POLARITY	Two-position toggle switch, applies output of either positive or negative pulse amplifier across PULSE AMPLITUDE potentiometer.
PULSE OUT	Binding post connected to arm of PULSE AMPLITUDE potentiometer.
GND	Binding post connected to metal chassis of instrument.
GATE OUT	Binding post to cathode-follower positive gate amplifier.

### **Type 162**

#### **Functions of Controls and Connectors**

MANUAL	Pushbutton (SW2) for initiating a pulse or chain of pulses manually.
+GATE IN	Panel connector for connecting an external source of positive gate voltage to the instrument.
+TRIGGER IN	Panel connector for connecting an external source of triggering voltage to the instrument.
OPERATING MODE	Five-Position, three-section rotary switch (SW1A,B,C) for selecting the source and mode of triggering action.
MAN., ONE CYCLE	One phantastron run-down occurs each time MANUAL pushbutton is depressed.
MAN., CONTINUOUS	Phantastron runs recurrently during period MANUAL pushbutton is depressed, and completes a rundown if pushbutton is released before a rundown is completed.
RECURRENT	Phantastron runs recurrently as long as OPERATING MODE switch remains in this position.
GATED	Connects +GATE terminal to triggering circuits. Phantastron operates recurrently during period of gate. Completes run-down if gate terminates during a run-down.
TRIGGERED	Connects +TRIGGER terminal to triggering circuits. Phantastron executes one run-down for each positive pulse received.
CAL	Screwdriver adjustable 50-k resistor in voltage divider of phantastron discharge circuit. Correct setting of this control makes WAVEFORM DURATION dial direct reading.
VERNIER	Potentiometer in phantastron discharge circuit for vernier control of wave-

form duration or repetition rate. Must be set on the CALIBRATED POSITION index for WAVEFORM DURATION dial to read correctly.

WAVEFORM DURATION or PULSE INTERVAL	Eleven-position switch varies phantastron discharge resistance to give a time variation of ten-to-one.
MULTIPLIER	Five-position switch selects phantastron timing capacitors to give decade series of time multipliers between 0.1 and 1000 times the reading of the WAVEFORM, INTERVAL dial.
GATE OUT, PULSE OUT	Two-position toggle switch selecting dc or ac coupling to shaping amplifier, thereby determining type of output at panel connector located immediately below the switch.
SAWTOOTH OUT	Panel connector from cathode of phantastron plate to grid coupling cathode-follower.

### **Type 163 Functions of Controls and Connectors**

INPUT	Connector to TRIGGER SELECTOR switch for connecting external trigger source.
TRIGGER SELECTOR	Two-position toggle switch to accommodate input circuit to POS. PULSE input or NEG. SAWTOOTH input.
OUTPUT PULSE DELAY	Variable potentiometer to adjust comparison voltage in voltage-comparator circuit to compare with sawtooth triggering waveform.
POS. TRIGGER BIAS	Same variable potentiometer as above, adjusts operating bias of pulse amplifier for most satisfactory triggering.
NEG. DELAY LIMIT	Screwdriver-adjustable resistor in series with negative end of OUTPUT PULSE DELAY potentiometer, for adjusting low-voltage triggering level of voltage-comparator circuit to accommodate scale calibrations to various sawtooth amplitudes.
POS. DELAY LIMIT	Screwdriver-adjustable resistor in series with positive end of OUTPUT PULSE DELAY potentiometer, for adjusting low-voltage triggering level of voltage-comparator circuit to accommodate scale calibrations to various sawtooth amplitudes.
PULSE WIDTH	Four-position switch selects value of coupling capacitor in pulse-generating multivibrator, determines discharge time in conjunction with PULSE WIDTH MULTIPLIER variable resistor, and thereby determines pulse width.
PULSE WIDTH MULTIPLIER	Continuously-variable resistor in coupling circuit of pulse-forming multivibrator, determines discharge time in conjunction with PULSE WIDTH selected capacitor, thereby determines pulse width.

PULSE WIDTH CALIBRATOR	Screwdriver adjustable voltage-pickoff potentiometer, adjusts negative bias on pulse-generator multivibrator to accommodate PULSE WIDTH calibrations to characteristics of multivibrator tube. May require readjustment when multivibrator tube is replaced.
PULSE AMPLITUDE CALIBRATOR	Screwdriver-adjustable potentiometer which adjusts the bias on the output cathode follower to accommodate PULSE AMPLITUDE calibrations to characteristics of cathode-follower tube.
PULSE AMPLITUDE	Voltage-pickoff variable potentiometer with contact arm connected to PULSE OUT terminal, determines percentage of developed pulse that is made available to output terminal. Calibrated in volts.
PULSE OUT	Binding post connected to arm of PULSE AMPLITUDE potentiometer.
GATE OUT	Binding post to cathode-follower gate amplifier.

#### Standard Accessories

See standard accessory lists in this manual for accessories supplied with each instrument. For optional accessories, see the current Tektronix, Inc. catalog.



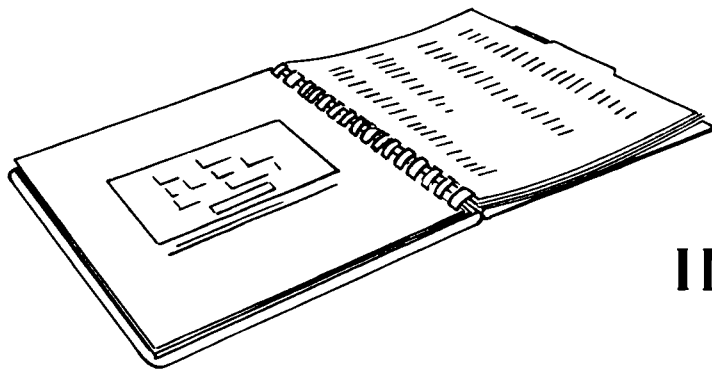

## SECTION 2

# OPERATING INSTRUCTIONS

### **Type 162**

#### **General**

The Tektronix 160-Series instruments, including the Type 360 Indicator and the Type 126 Power Supply, may be operated in any normal indoor location, or in the open if protected from moisture. If an instrument has been exposed to moisture, it should be left in a warm room until it has become thoroughly dry before placing it in operation.

#### **Power Supply Requirements**

Power for the 160-Series instruments can be furnished by the Type 160A Power Supply or any well regulated power supply capable of furnishing the required voltages and current. Specifications and requirements for the instruments are given in the Specifications section of this manual. If a Tektronix Type 160 or Type 160A Power Supply is used, install the interunit octal-plug power cable.

When connecting a Type 360 to a 160A, be sure to use a separate power cable for each 360 as the filament current would be too high for more than one unit. Several of each of the other 160 series units can be operated from one power cable.

#### **Multiple Connection of Type 160-Series Instruments**

The 160-Series Pulse Generators and the Type 360 Indicator are equipped with one male octal input power receptacle and one female output socket connected in parallel. Additional units may be connected by means of additional interunit power cables.

The SAWTOOTH OUT waveform of the Type 162 is specially designed to provide the required NEG. SAWTOOTH input waveform for the TEKTRONIX Type 161 Pulse Generator so as to obtain pulse sequences with precise and adjustable delay between the initiating pulse and the

output pulse, and to provide a stable source of repetition rate for the Type 161.

### **Type 360**

#### **Preliminary Instructions**

#### **Mounting**

If the Type 360 is to be rack mounted in the FA 160 Mounting Frame or in a mounting of your own construction do not place the instrument immediately adjacent to the 160 Power Supply as the external magnetic field of the fan motor may affect the crt display. One of the other 160 Series instruments placed between the power supply and the indicator will provide sufficient isolation. Or you can safely place the 360 above or below the 160A.

#### **Illuminated Graticule**

The brightness of the illuminated graticule can be adjusted to suit ambient light conditions by means of the SCALE ILLUM control. The filter supplied is colored to provide the maximum trace contrast for the P2 phosphor in the presence of room light. Place the filter next to the crt face so it does not block the light from the graticule lines. The scribed face of the graticule should be toward the crt face to reduce parallax.

The graticule is accurately scribed in quarter-inch divisions. These scale markings and the calibrated vertical-deflection sensitivities can be used to convert deflection in centimeters into volts of signal amplitude. If a 162 is used to provide the sweep sawtooth for the 360 Indicator a similar conversion can be made to yield time in seconds so the amplitude and duration of the displayed waveform can be read directly from the scribed graticule.

As a general rule, white graticule lines are superior to red for photographic purposes.

Where the volume of photographic work warrants it, you may want to obtain a clear graticule from your Tektronix Field Engineer.

### **Cathode-Ray Tube Controls**

At normal INTENSITY settings the crt beam is biased off and a positive 50-volt unblanking gate is required to turn the beam on and produce a visible trace. You can, however, increase the INTENSITY enough to produce a visible trace without the unblanking gate but the retrace will be visible at the faster sweep speeds.

The ASTIGMATISM control is preset for the particular crt and accelerating voltage and normally will not need to be readjusted. The FOCUS and INTENSITY adjustments interact slightly so that the FOCUS may need to be touched up slightly for different INTENSITY settings.

### **FIRST-TIME OPERATION**

The following material will assume the Type 360 Indicator will be used with the Tektronix 160 Series. If you are going to use the indicator with other equipment check further in this section of the manual for the required operating conditions.

Plug the power cable into the male plug of the Indicator unit and connect the other end to the power supply.

Connect a lead between the +GATE INPUT binding post on the 360 and the GATE OUT, PULSE OUT binding post on the 162. Connect another lead between the SAWTOOTH INPUT binding post on the 360 and the SAWTOOTH OUT binding post on the 162.

Set the front-panel control on the 360 and the 162 as follows:

#### **360 CONTROLS**

FOCUS	center
INTENSITY	full left
VOLTS/DIV	50
VARIABLE	full right
POSITIONING	
VERT	center
HORIZ	center
AC, DC	AC

#### **162 CONTROLS**

OPERATING MODE	RECURRENT
VERNIER	CALIBRATED
	POSITION
WAVEFORM DURATION	1.0
MULTIPLIER	1.0
GATE OUT, PULSE OUT	GATE OUT

Switch the power supply on and wait about 30 seconds for the tube heaters to reach operating temperature. Advance the indicator INTENSITY control until the trace is visible and adjust the FOCUS control if necessary to make the trace as fine as possible.

### **Sweep Timing**

The accuracy with which you can read time directly from the ruled graticule will depend on the calibration of both instruments. The Type 162 generates a sawtooth of known duration. With the controls set as suggested for "First-Time Operation" the sawtooth duration is 10 milliseconds. If the indicator's horizontal amplifier is adjusted so this 10-millisecond sawtooth will produce a trace that is exactly 10 divisions long then time can be read directly from the graticule lines. In this case the sweep speed is 1 millisecond per division. Always make sure the duration of the sawtooth as indicated by the 162 WAVEFORM DURATION control is correct and then adjust the 360 SWEEP CAL control so the displayed sweep is 10 divisions long. For a more accurate method of timing the sweep see the MAINTENANCE section.



## Vertical Amplifier

Input to the vertical amplifier is made via the UHF connector labeled VERTICAL INPUT. The VOLTS/DIV control establishes the sensitivity of the vertical amplifier. There are four fixed calibrated sensitivities of 0.05, 0.5, 5 and 50 volts/div and the VARIABLE control has a range of a little over 10 to 1 so the sensitivity is continuously variable between calibrated steps.

## Operation With Other Equipment

There are several requirements for operation of the 360 that are taken care of automatically when the Indicator is used with the 160 Series Power Supply and Waveform Generator. The first requirement is power to operate the indicator. The +225-volt and the -170-volt supplies should be within about 5% of these values and should be well regulated as they determine the operating potentials of the amplifiers and serve as reference potentials for the regulated high-voltage supply. The unregulated 300-volt supply which furnishes power to the high-voltage oscillator can be as low as 250 volts or as high as 350 volts or you can use a regulated supply for this but there is very little to be gained as the high-voltage supply has its own regulation. The heater supply should be within +or- 10% of 6.3 volts at full load as recommended by tube manufacturers.

The horizontal amplifier will accommodate either a positive-going or negative-going sawtooth and the total sawtooth excursion and dc level can vary within limits. The minimum practical sawtooth excursion is about 110 volts and the excursion must be within the limits of about -95 volts to +170 volts. The maximum practical excursion is about 150 volts and should be within the limits of -90 volts to +160 volts as the horizontal positioning range is less at this operating condition.

The general procedure for adapting the 360 for a sawtooth that falls within the above specifications is as follows:

1. Remove the cabinet so the internal controls are accessible and switch the SAWTOOTH

POLARITY switch to either POSITIVE SAWTOOTH or 162SAWTOOTH depending on whether you will use a positive or negative-going sawtooth. Make all power and front-panel connections to the 360 and turn the equipment on. Center the SWEEP CAL control (screwdriver slot straight up and down) so you will have a fine adjustment in both directions after you make the coarse adjustment.

2. Change the crt accelerating voltage by means of the H. V. ADJ control so the displayed trace is about 10 divisions long. The H. V. ADJ control can be reached with a screwdriver through a slot in the shield at the lower right rear of the instrument. Make any final adjustment with the SWEEP CAL control.

### NOTE

When you change the crt accelerating voltage you change the vertical sensitivity as well as the horizontal sensitivity so it will be necessary to recalibrate the VOLTS/DIV switch.

The unblanking signal should be a flat-topped positive square wave of about 45 to 75 volts amplitude. If the rise time of the unblanking waveform is too long the first part of the trace will not be visible and as the unblanking waveform is dc coupled to the crt grid any tilt to the top of the square wave will cause a variation of trace intensity.

## Type 161

### General

The TEKTRONIX Type 161 Pulse Generator will operate in any normal indoor location, or in the open if it is protected from moisture. If the instrument has been exposed to moisture, leave it in a warm dry room until it is thoroughly dry before placing it in operation.

Operate the instrument in such a way that good ventilation can take place, so that high internal temperatures will not occur. All components are well supported and the instrument is quite rugged, but it should not be roughly handled.

## FIRST-TIME OPERATION

Power for the Type 161 Pulse Generator can be furnished by the TEKTRONIX Type 160, Type 160A Power Supply, or by any well-regulated supply capable of furnishing the required voltages and currents.

If the TEKTRONIX Type 160 or 160A Power Supply is used, install the interunit octal-plug power cable. No particular precautions are required before power is applied to the unit.

The Type 161 must be triggered from an external source with a trigger waveform of the proper characteristics. The TEKTRONIX Type 162 Waveform Generator will furnish both the required pulse and sawtooth waveforms. The following is a list of convenient settings of controls for observing the operation:

TRIGGER SELECTOR	POS. PULSE
POS. TRIGGER BIAS	.3
PULSE WIDTH	1
PULSE WIDTH	1
MULTIPLIER	1
PULSE AMPLITUDE	20
PULSE POLARITY	POS.

Connect a step voltage to the INPUT terminal which has a peak of at least six volts, and observe the output of the PULSE OUT terminal on an oscilloscope, such as TEKTRONIX Type 540 series. Set the sweep time of the oscilloscope at approximately 1 millisecond per centimeter, and a pulse will appear approximately 1 centimeter long.

### Method of Triggering the Type 161 Pulse Generator

Two triggering waveforms may be used: a positive pulse or a negative-going positive sawtooth. The positive pulse requirements are not strict. Any positive peak value above 2 volts will consistently trigger a pulse. The maximum peak voltage should not exceed about 250 volts. Fig. 2-1 shows a simple battery connection for triggering the Type 161.

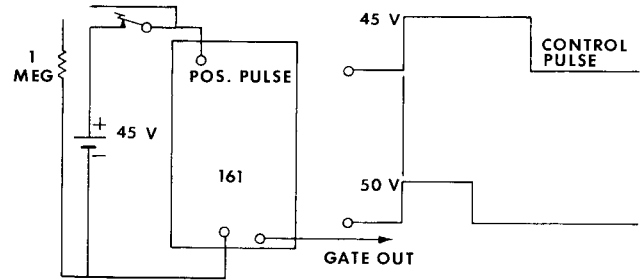

Fig. 2-1. An external battery connected to trigger the Type 161.

The negative-going sawtooth must have a dc component such that it does not go below about 20 volts positive at any part of the cycle. The maximum positive excursion of the sawtooth should not exceed about 200 volts. The Type 162 Waveform Generator will furnish a suitable sawtooth triggering waveform.

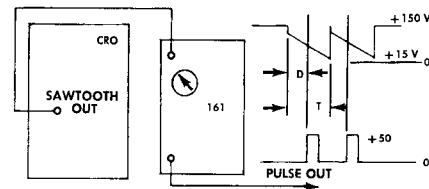

Fig. 2-2. The Sawtooth Out waveform from the Type 162 Waveform Generator is used to trigger the Type 161. Note that the output pulse from the Type 161 may be delayed with respect to the triggering waveform.

## Type 162

### First Time Operation

No particular precautions are required before power is applied to the unit. The following is a convenient setting of controls for observing the operation: Set the OPERATING MODE switch to RECURRENT, the VERNIER control to CALIBRATED POSITION, the WAVEFORM DURATION switch to 1.6, and the MULTIPLIER switch to 10. With these settings, a sawtooth wave of about 60-cycle frequency should be observable at the SAWTOOTH OUT terminal using an oscilloscope such as the TEKTRONIX Type 540 series. Similarly, a pulse or gate should be observable at the PULSE OUT, GATE OUT terminal, depending upon the position of the toggle switch, located immediately above the terminal, which determines whether gate or pulse output is produced.

### Method of Triggering and Gating the Type 162

A basic method of triggering the Type 162 is the use of a radio B battery connected

between one of the two input terminals and the ground terminal of the instrument, through a pushbutton or momentary switch. Although the instrument will trigger on eight or ten volts, a 22 1/2 -volt or 45-volt B battery provides a very dependable trigger source.

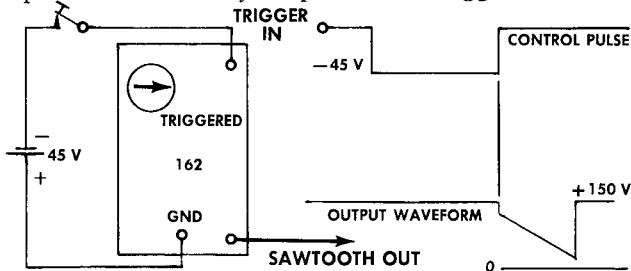

Fig. 2-3. An external battery used as the negative trigger source for a Type 162. Note that the output sawtooth starts as the triggering waveform becomes positive-going.

If the battery is connected as shown in Fig. 2-3, with the negative terminal of the battery connected to the +TRIGGER IN, triggering will not take place when the switch is depressed, but when it is released, as shown in Fig. 2-3. The instrument will not be operated at all if the battery is connected in this manner to the +GATE IN.

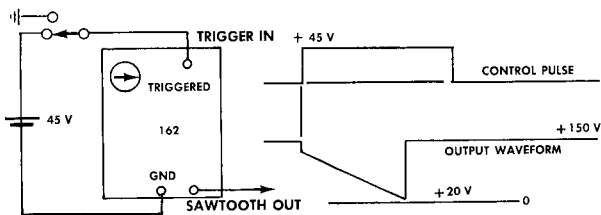

Fig. 2-4. An external battery used as the positive trigger source for a Type 162. Note that the output sawtooth starts as the triggering waveform becomes positive-going. Note also that the switch in its normally open position connects to ground.

A more usual method of connecting a battery triggering source is shown in Fig. 2-4, where the positive terminal of the battery is connected to the instrument input terminal, in this case to the +TRIGGER IN terminal, and the OPERATING MODE switch is turned to the extreme right to the TRIGGERED position. As shown in Fig. 2-4 the output wave commences at the same time as the input pulse.

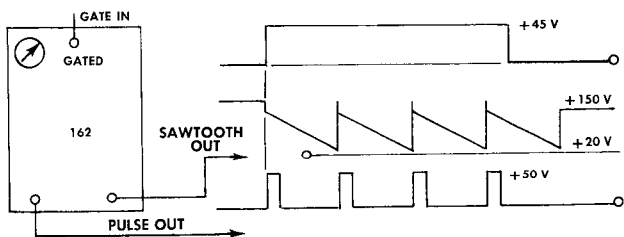

Fig. 2-5. The Type 162 connected for gated operation. Note the relationship between the waveforms.

Fig. 2-5 shows input and output waveforms when the input signal is connected to the +GATE IN terminal, and the OPERATING MODE switch is turned to the GATED position. Output commences when the input gating signal begins, and continues until the input signal returns to zero. If a sawtooth has begun before the termination of the gating signal, it will be completed even though the gating signal has already returned to zero. At the PULSE OUT terminal, a series of pulses will be available, the first pulse occurring simultaneously with the start of the gating signal, and subsequent pulses occurring at the start of subsequent sawtooth waves.

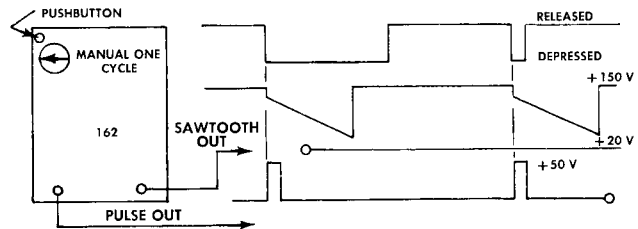

Fig. 2-6. The Type 162 operated in the Manual, One-Cycle, Operating Mode.

Fig. 2-6 shows the output waveform with relation to the position of the MANUAL push-button control when the OPERATING MODE switch is in the MANUAL, ONE CYCLE position. A single sawtooth and a single pulse are produced regardless of the length of time the pushbutton remains depressed.

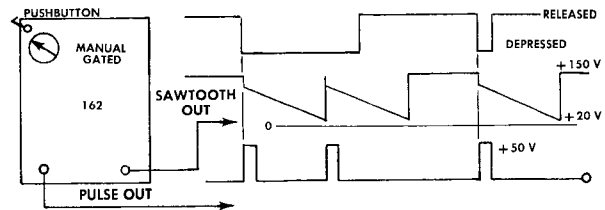

Fig. 2-7. The Type 162 operated in the Manual, Recurrent, Operating Mode.

Figure 2-7 shows the output waveform with relation to the position of the MANUAL push-button control when the OPERATING MODE switch is in the MANUAL, CONT. position. A recurrent sawtooth and a series of pulses are produced as long as the button remains depressed. A sawtooth which is started just before the release of the pushbutton will continue until an entire sawtooth waveform is completed.

## **Type 163**

### **Methods of Triggering the Type 163 Pulse Generator**

The Type 163 must be triggered from an external source with a trigger waveform of the proper characteristics. The TEKTRONIX Type 162 Waveform Generator will furnish both the required pulse and sawtooth waveforms. The following is a list of convenient settings of controls for observing the operation. Set TRIGGER SELECTOR switch to POS. PULSE position, POS. TRIGGER BIAS to 0.6, PULSE WIDTH to 1000 microseconds, PULSE WIDTH MULTIPLIER to 1, PULSE AMPLITUDE to 20. Connect a step voltage which has a peak of at least six volts to the INPUT terminal and observe the output at the PULSE OUT terminal using an oscilloscope such as TEKTRONIX Type 540 series. Set the sweep time of the oscilloscope at approximately 1 millisecond per centimeter, and a pulse will appear approximately 1 centimeter long with the foregoing settings.

Two triggering waveforms may be used: a positive pulse or a negative-going positive sawtooth. The positive pulse requirements are not strict. Any positive peak value above 2 volts will consistently trigger a pulse. The maximum peak voltage should not exceed about 250 volts.

Triggering is similiar to that used with the Type 161. Refer to Figures 2-1 and 2-2 for suitable hookups.

The negative-going sawtooth must have a dc component such that it does not go below about 20 volts positive at any part of the cycle. The maximum positive excursion of the sawtooth should not exceed about 200 volts. The Type 162 Waveform Generator will furnish a suitable sawtooth triggering waveform. See "Maintenance" for instructions for calibrating the OUTPUT PULSE DELAY dial.

### **Applications**

Many combinations of Tektronix 160-Series instruments are possible. The following material illustrates a few of these combinations. While these applications have been prepared with a slant toward biological research fields,

they are intended to acquaint you with some of the possible uses of the Type 160-Series Units.

### **Explanatory Note**

In examining these waveforms on an oscilloscope the waveform to be examined may be used as an initiating pulse to trigger the oscilloscope sweep, due attention being paid to the polarity of the waveform. This is accomplished by connecting the output to be examined with the External Trigger binding post on the oscilloscope, and making the proper adjustments of TRIGGER MODE, STABILITY and TRIGGERING LEVEL. It should be borne in mind that the sweep transit time must be equal to or longer than the duration of the waveform to be examined if the entire waveform is to be seen on the sweep. If the sweep transit time is less than the waveform duration, only a portion of the waveform will be seen. The waveform to be examined is impressed on the vertical deflection plates by connecting the vertical amplifier probe with the output terminal under examination.

### **Initiating Pulses**

#### **A. For 161**

1. Negative-going sawtooth from Tektronix scope.
2. Negative-going sawtooth from 162.
3. Positive-going pulse from delayed trigger output of scope.
4. Positive-going pulse from 162.
5. Positive-going pulse from external source.
6. Negative-going pulse derived from flyback of conventional oscilloscope sweep generator.

#### **B. For 162**

1. Any positive-going pulse may be used for triggered operation.
2. Any positive-going waveform may be used for gated operation, the 162 recycling for the duration of the waveform.

### 1a. Initiating pulse derived from Tektronix Type 162

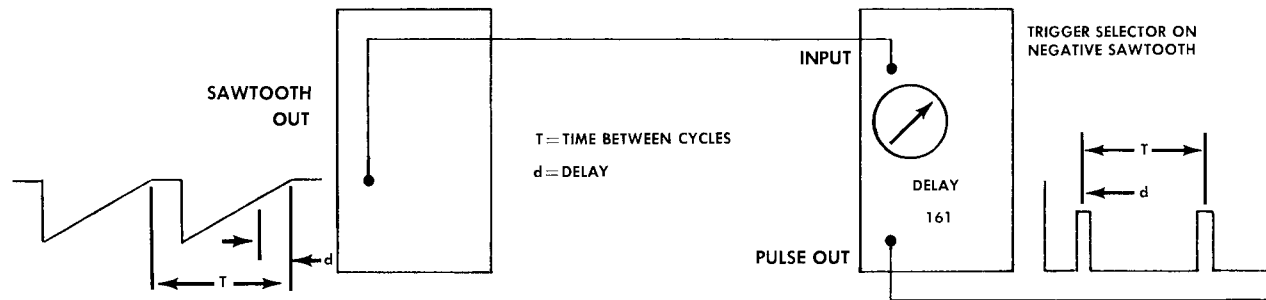

Fig. 2-8. Free running Type 162 determines rate of 161 pulse formation. Position of pulse on sweep determined by delay setting of 161. Parameters of pulse determined by amplitude and duration controls on 161.

### 1b. Initiating pulse derived from Tektronix 540 Series Oscilloscope

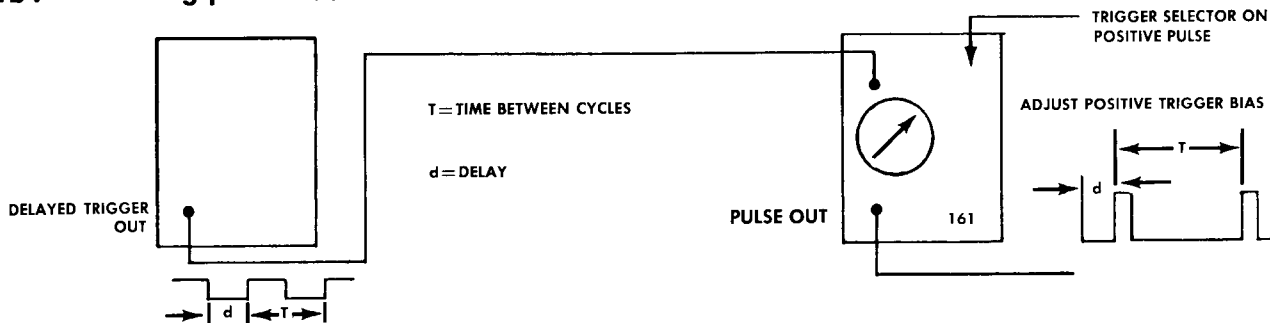

Fig. 2-9. Free running oscilloscope sweep determines rate of 161 pulse formation. Position of pulse on sweep determined by delayed trigger control on panel of oscilloscope. Parameters of pulse determined by amplitude and duration controls on 161.

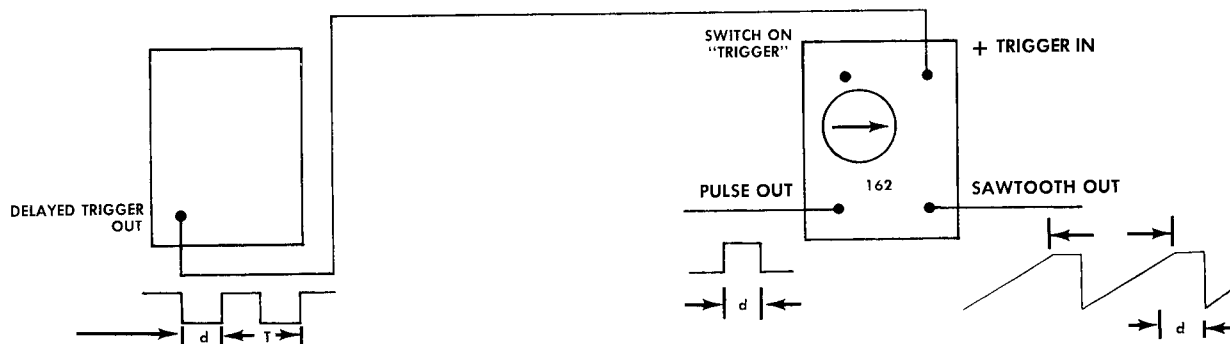

Fig. 2-10. Free running oscilloscope sweep determines rate of 162 sawtooth formation. Position of beginning of sawtooth pulse determined by setting of delayed trigger control on panel of oscilloscope. Duration of sawtooth determined by setting of waveform duration controls on panel of 162. A positive-going gate of the same duration as the sawtooth may be obtained simultaneously from the other output connection.

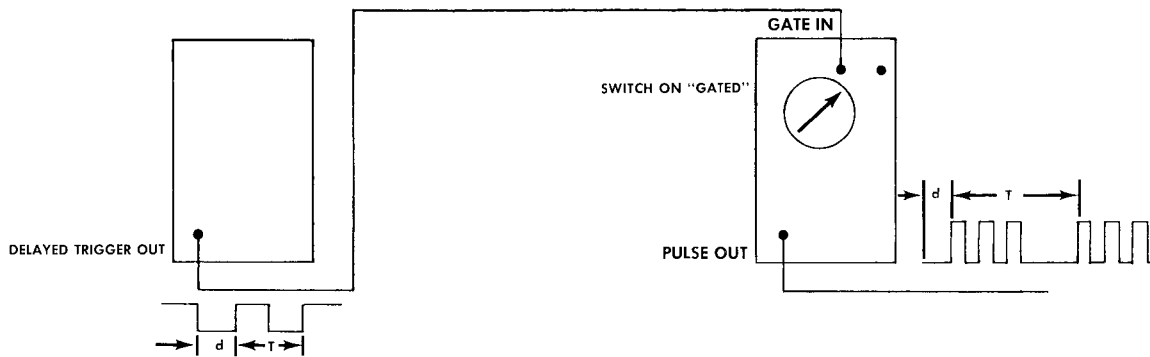

Fig. 2-11. Free running oscilloscope sweep determines rate of 162 pulse formation. Position of pulse with relation to sweep determined by delayed trigger control on panel of oscilloscope. Interval between pulses out of 162 determined by pulse interval controls on panel of 162. If this interval is longer than the oscilloscope sweep interval, the 162 will not pulse with each sweep. If this interval is equal to the oscilloscope sweep interval, the 162 will pulse once with each sweep. If this interval is shorter than the oscilloscope sweep interval, the 162 will pulse as many times as it can during the period of positivity of the delayed trigger output. A negative-going sawtooth is available at the other output terminal starting simultaneously with each pulse.

## II. Initiating pulse derived from external source other than oscilloscope

This requires only some means of controlling a source of voltage in excess of 8-10 volts. A manually operated switch or a mechanically operated switch in a circuit containing the required source of voltage will supply the

necessary pulse each time the switch contacts close or open. Since both the 161 and 162 respond to positive-going pulses, the following conditions establish the characteristics of operation:

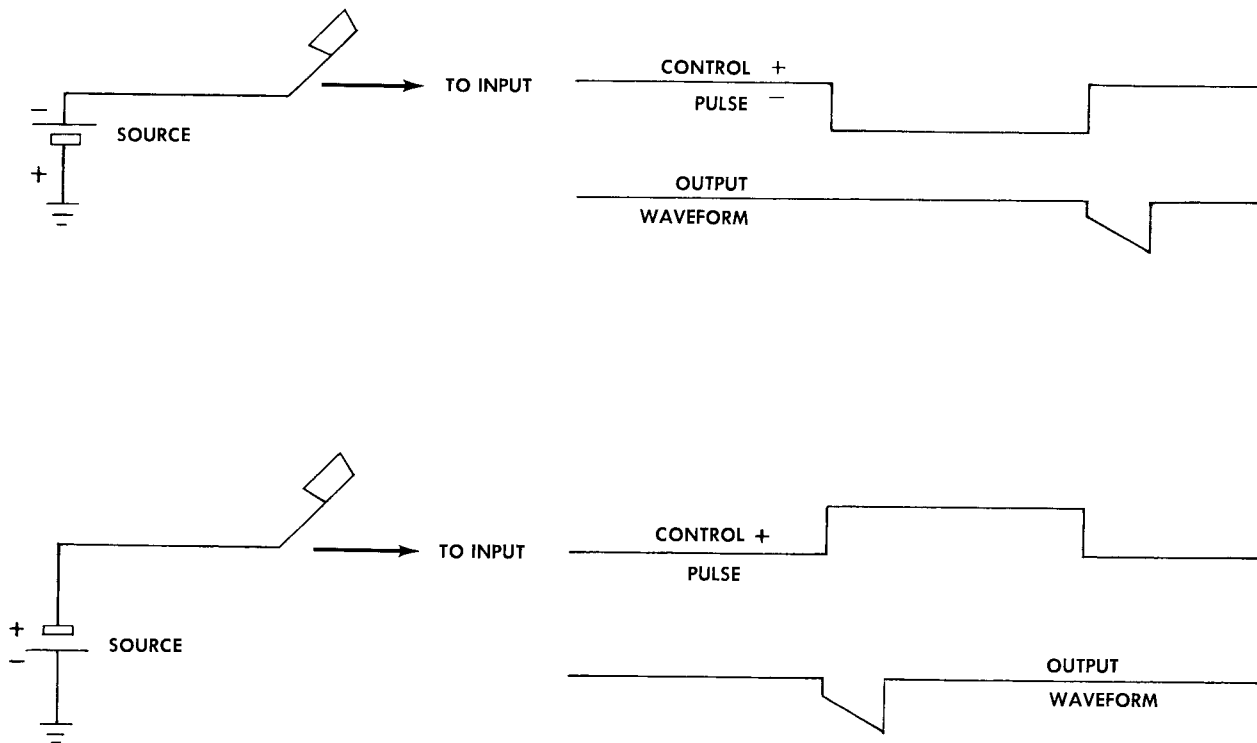

Fig. 2-12. Since the initiating pulses are positive-going waveforms, more predictable and less confusing operation will probably be obtained if the control pulse is habitually obtained from the positive terminal of the source.

A. 162 Triggered.

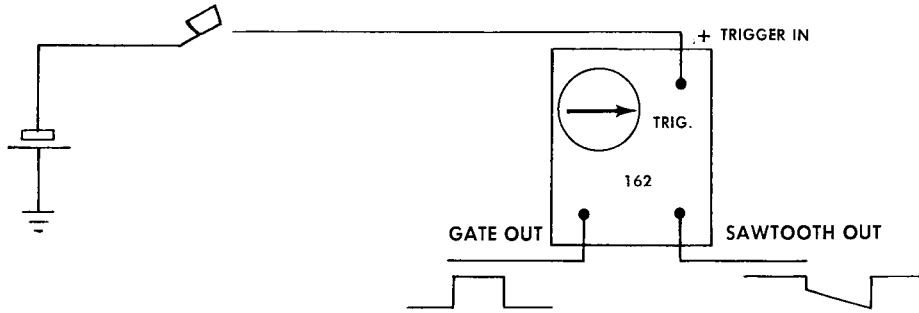

Fig. 2-13. The output gate and sawtooth durations are identical and are determined by panel control settings. The operation occurs once only, at the time of switch closure, and will not recur until the output cycle is complete, the switch opened and then closed again.

B. 162 Gated. Duration of switch closure 1 sec.

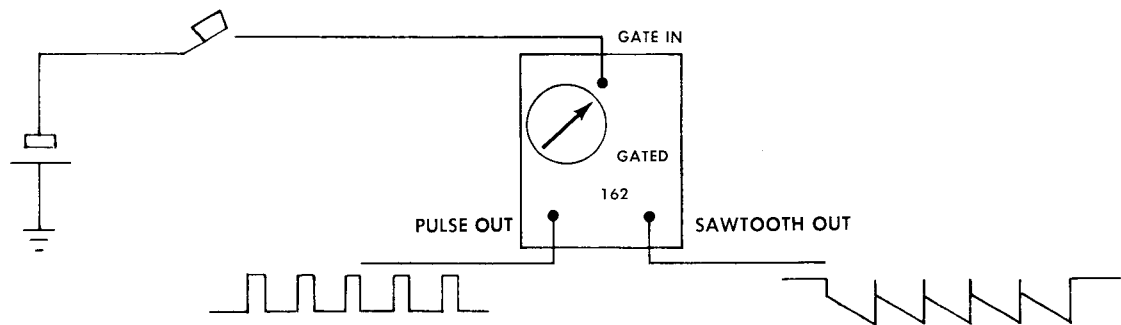

Fig. 2-14. The output gate and sawtooth durations are identical and are determined by the panel control settings. If these durations are set at 1 sec. or more, the operation will occur once each time the switch is closed. If these durations are less than 1 second, the operation will recycle for the entire 1 second of switch closure. The number of cycles will be given by the quotient of duration of switch closure divided by the waveform duration.

C. 161 Triggered.

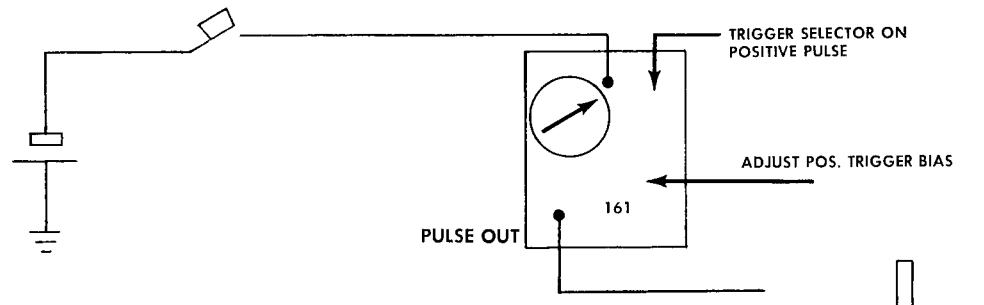

Fig. 2-15. The pulse formation starts at the instant of switch closure. The dimensions of the pulse are determined by the panel control settings.

**III. Operation independent of external initiating pulse**

A. The 161 pulse generator will not operate in this way. It requires an initiating pulse.

B. 162 on Recurrent operation.

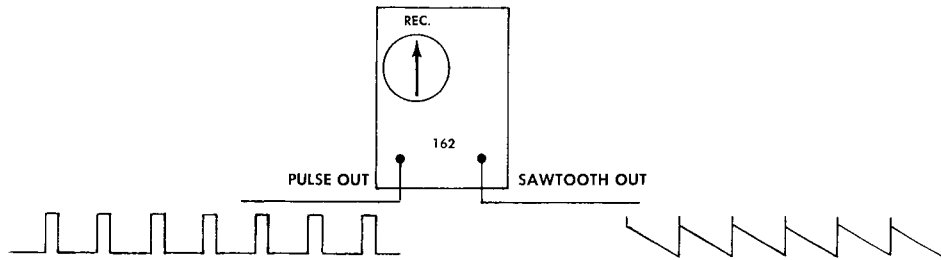

Fig. 2-16. Two outputs are available. Positive-going pulses occur at intervals determined by the controls on the panel. Negative-going sawtooths occur at the same intervals. The rundown of the sawtooth starts at the time of each pulse and continues throughout the interval between pulses. This operation continues as long as the selector is on Recurrent and the proper voltages are supplied.

C. 162 on Manual-Recurrent.

Operation similar to Recurrent (IIIB) occurs whenever the pushbutton switch is depressed and continues as long as the switch is held down.

D. 162 on Manual-One Cycle.

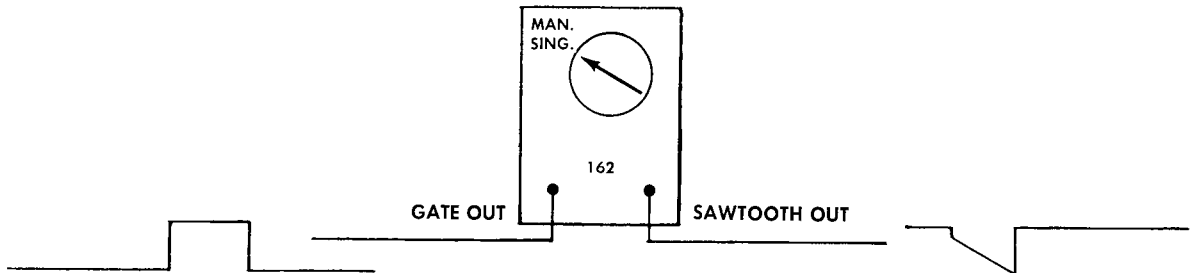

Fig. 2-17. Two outputs are available. A positive-going gate occurs once each time the switch is depressed. It starts at the time the contacts close and endures for an interval which is determined by the settings on the panel controls. A negative-going sawtooth occurs once each time the switch is depressed. It starts at the time the contacts close and endures for an interval determined by the settings on the panel controls. The operation will not recur until the push-button switch is released and depressed once again.

**IV. Combined unit operations**

A. 1) Double pulse formation. Basic interval supplied by oscilloscope sweep.

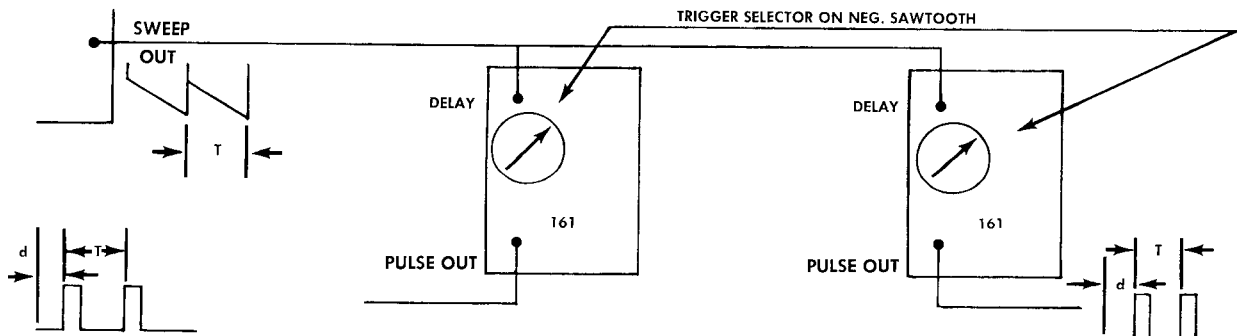

Fig. 2-18. The timing of each pulse with reference to the sweep is controlled by the delay setting on the 161 panel. The dimensions of each pulse are determined by the pulse duration and amplitude controls.



A. 2) Double pulse formation. Basic interval supplied by 162.

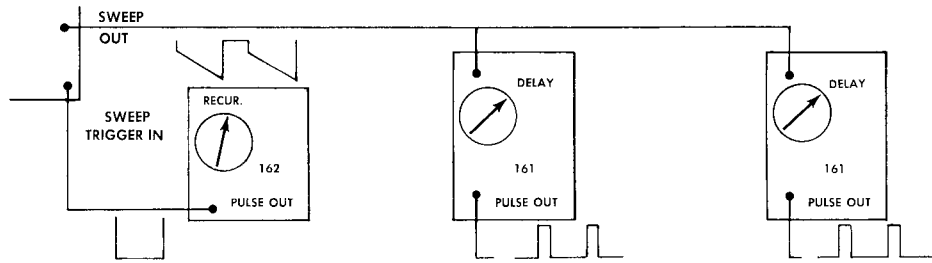

Fig. 2-19. The interval at which all operations recycle is determined by the interval settings on the controls of the 162 operating recurrently. The timing of each pulse with reference to the sweep is determined by the delay settings on the dials of the 161's. The dimensions of each pulse are determined by the pulse duration and amplitude controls on the 161's.

A. 3) Double pulse formation. Basic interval supplied from external source.

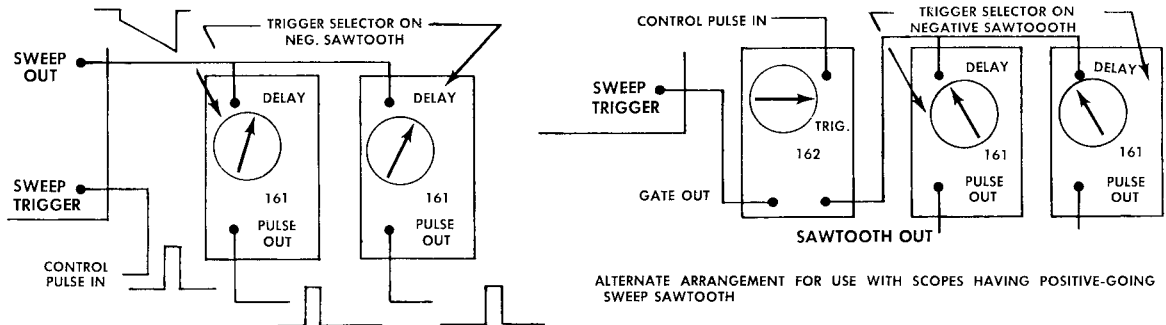

Fig. 2-20. All operations recycle at interval determined by control pulse. Delays and dimensions of output pulses determined by control settings of 161's.

B.1) Multiple pulse formation. Basic interval supplied by external pulse. Repetitive pulse formation required during a fraction of sweep transit time.

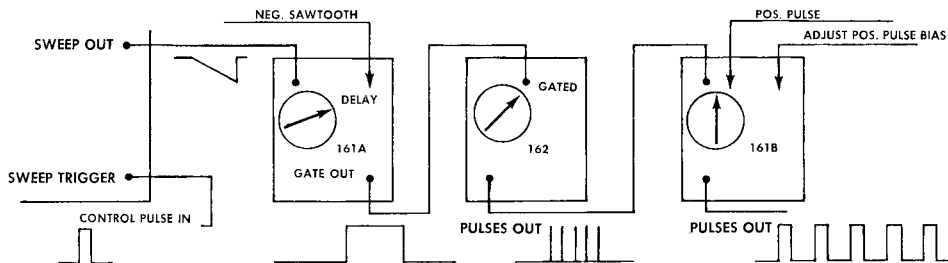

Fig. 2-21. All operations recycle at interval determined by control pulse. This initiates sweep of oscilloscope and sawtooth input to 161A. At a given time, determined by the delay setting of 161A, a positive-going gating pulse is initiated. The duration of the gate is determined by the duration settings of 161A. The 162 operates recurrently during a period determined by the gate from 161A. The frequency of operation of 162 is determined by the interval setting on the control panel of 162. The recurrent pulse output from 162 thus consists of a train of pulses of controlled time of initiation, controlled train duration and controlled repetition rate. The 161B produces a pulse out for each individual pulse in from the 162. The duration and amplitude controls the 161B permit control of the individual pulse dimensions in the train.

B.2) Multiple pulse formation. Basic interval supplied by external pulse. Repetitive pulse formation required during a fraction of sweep transit time. Single pulse required at variable position with reference to sweep.

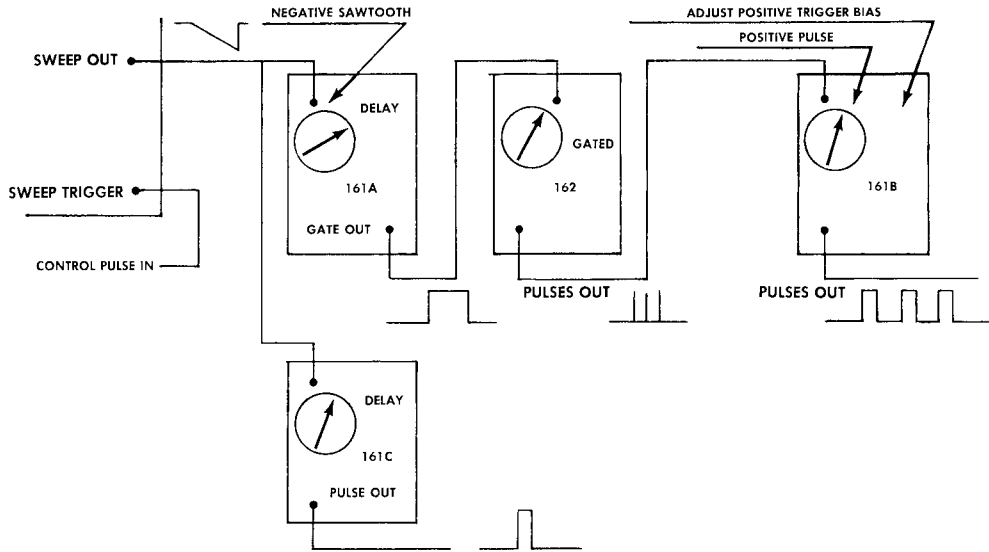
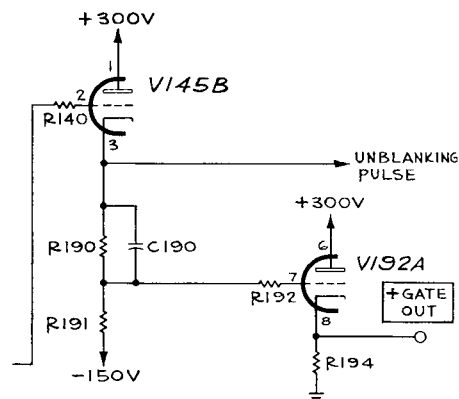

Fig. 2-22. 161A, 162 and 161B operate as described in Paragraph B2. 161 forms a single pulse at a time determined by its delay control setting having dimensions determined by its duration and intensity controls.

## SECTION 3

# CIRCUIT DESCRIPTION



### Type 126

#### General

Rectifiers V118 and V120 are conventional full-wave rectifiers. Electrolytic capacitors C118 and C120 are used as filters.

#### -170-Volt Regulated Supply

The negative 170-volt supply is regulated by comparing the voltage of the reference tube, V105, with the voltage from a voltage divider connected between ground and the -170-volt bus. The error signal is amplified in V110 and applied to the grid of V115. This amplified error signal changes the series resistance of V115 in the proper direction to correct the output voltage. A screwdriver adjustment, labeled -170 ADJUST, permits the voltage to be set correctly. The remaining two regulated supplies are referenced to the -170-volt bus.

#### +225-Volt Regulated Supply

The positive 225-volt supply is regulated by comparing with ground potential the voltage from a voltage divider connected between the +225-volt bus and the -170-volt bus. The error signal is amplified in V130B and applied to the grid of V125, the series regulator tube.

#### +150-Volt Regulated Supply

A divider from the +225-volt supply to ground applies the proper voltage to the grid of V130A to obtain +150 volts at the cathode. Since very little current is required from this supply, no further regulation is used.

#### 300-Volt Unregulated Supply

The 300-volt output is obtained from the unregulated side of the 225-volt supply. This supply is used to supplement the 225-volt supply to provide the required current for the 160-Series instruments.

#### 6.3-Volt AC Unregulated Supply

This voltage is supplied from a 6.3-volt winding on the power transformer. Current from this winding should not exceed 4 amps.

#### Type 160

The Type 160 Power Supply has been replaced by the Type 160A, an improved design. Circuit information on the Type 160 is included here, however, for the benefit of customers having these instruments.

Rectifier tubes V1 and V2 are conventional 5V4 full wave rectifiers. Electrolytic capacitor filters are used, consisting of C1, C2, C5 and C6.

#### -170-Volt Regulated Supply

The basic reference element is V5, a gas diode. The negative 170-volt supply is regulated by comparing the voltage of the reference tube, V5, with the voltage of a voltage divider connected between ground and the -170-volt bus. The error signal is amplified in V4, and applied to the grid of V3B, a series regulator triode. Current available is limited to 125 ma. A screwdriver adjustment R15A, labeled SET TO -170 V, in the voltage divider element, R15, A, B, and C, permits the voltage to be set accurately. The remaining two regulated supplies are referred to the -170-volt bus.

### **+225-Volt Regulated Supply**

The reference element is the -170-volt bus. The positive 225-volt supply is regulated by comparing to ground potential the voltage of a voltage divider connected between the +225-volt bus and the -170-volt bus. The error signal is amplified in V6, and applied to the grid of V3A, a series regulator triode. Current available is limited to 125 ma. A screwdriver adjustment, R5A, labeled SET TO +225V, in the voltage divider network, R5A, B, and C, permits the voltage to be set correctly.

### **150-Volt Regulated Supply**

The reference element is the -170-volt bus. The positive 150-volt supply is regulated by comparing to ground potential the voltage of a voltage divider connected between the -170-volt bus and the +150-volt bus. The error signal is amplified in V7A, and applied to the grid of V7B, the other half of the same dual triode, which acts as a series regulator tube. Output from this bus is limited by the current limitation of V7B, and the existing load on the +225-volt supply, because this current is supplied from the +225-volt regulator.

### **300-Volt Unregulated Supply**

This output comes from the unregulated side of the series-regulator tube, V3A, and is used to supplement the 225-volt supply to provide the required current for six Type 161 or Type 162 generators. The use of the +300-volt source is not recommended for other purposes because of ac ripple. Current limitation is determined by the transformer secondary winding and the existing current through the +225-volt supply. The total current in the plate lead of V3A should not exceed 175 ma.

### **6.3-Volt AC Unregulated Supply**

This voltage is supplied from a 6.3-volt ungrounded winding on the power transformer. Filaments of all tubes in the three regulators are also supplied by this winding. Current available external to the supply is limited to 10 amps.

## **Type 160A**

### **General**

Rectifier tubes, V1, V30 and V31, are conventional fullwave rectifiers. Electrolytic capacitors, C1 and C30, are used as filters.

### **-170-Volt Regulated Supply**

The negative 170-volt supply is regulated by comparing the voltage of the reference tube, V6, with the voltage from a voltage divider connected between ground and the -170-volt bus. The error signal is amplified in V7A, and is applied to the grids of V16 and V17 via the cathode follower, V7B. A screwdriver adjustment, R10, labeled ADJ. -170 v, permits the voltage to be set correctly. The remaining two regulated supplies are referred to the -170-volt bus.

### **+225-Volt Regulated Supply**

The positive 225-volt supply is regulated by comparing with ground potential the voltage from a voltage divider connected between the +225-volt bus and the -170-volt bus. The error signal is amplified in V33 and applied to the grids of V35, the series-regulator tube. Current available is limited to about 175 ma by the limitation of the series tube, but this tube can be shunted with a 1500-ohm resistor to increase the current capability to 225 ma. A screwdriver adjustment labeled ADJ. +225 v permits the voltage to be set correctly.

### **+150-Volt Regulated Supply**

The reference element is the -170-volt bus. The positive 150-volt supply is regulated by comparing to ground potential the voltage of a voltage divider connected between the -170-volt bus and the +150-volt bus. The error signal is amplified in V47A, and applied to the grid of V47B, the series-regulator tube. Output from this bus is limited by the current limitation of the series tube and the existing load on the +225-volt supply, because this current is supplied from the +225-volt regulator.

## **+300 Volt Unregulated Supply**

This output comes from the unregulated side of the series-regulator tube, V35 and is used to supplement the 225-volt supply to provide the required current for the 160-Series instruments. The use of the +300-volt source is not recommended for other purposes because of ac ripple. Current limitation is determined by the transformer secondary winding and the existing current through the +225-volt supply. The total current from the plus-supply rectifiers should not exceed 250 ma.

## **6.3 Volt AC Unregulated Supply**

This voltage is supplied from a 6.3-volt winding on the power transformer. Filaments of all tubes in the three regulators are also supplied by this winding. Current available external to the supply is limited to 20 amps.

## **Type 360**

### **VERTICAL AMPLIFIER**

#### **Input Connection**

Input is made to the vertical amplifier by way of the UHF connector labeled VERTICAL INPUT. Blocking capacitor C10 is shorted out in the DC position of SW9 and labeled AC-DC.

#### **Input Attenuators**

Frequency-compensated rc attenuators are switched into the amplifier input circuit by the VOLTS/DIV switch. Two attenuators are used singly or cascaded to produce four calibrated sensitivities.

#### **Phase Inversion Stage**

V30 and V32 comprise a cathode-coupled phase-inverter amplifier. Gain of the amplifier is adjustable by means of R34 which determines the amount of coupling between the cathodes. The front-panel screwdriver control labeled DC BAL adjusts the dc grid voltage of V32 so its cathode is at the same dc potential as the cathode of V30. When this control

is properly set no change in vertical positioning will occur when the VARIABLE control is varied.

### **Vertical Positioning**

Vertical positioning is produced by a dual potentiometer connected to the plates of the phase-inverting amplifier so the current through one plate load is increased when the potentiometer is adjusted to reduce the current through the other plate load.

### **Output Stage**

V50 and V52 provide the additional gain required to bring the signal to the proper level for application to the crt vertical-deflection plates. The front-panel screwdriver adjust, R56, introduces variable degeneration between the cathodes permitting the gain to be set so the VOLTS/DIV setting will agree with the trace deflection when the VARIABLE gain control, R34, is turned full right to the CALIBRATED position.

### **Voltage-Setting CF**

V72A provides a low-impedance source for the reduced plate and screen voltage required for the phase-inversion stage tubes, V30 and V32.

### **HORIZONTAL AMPLIFIER**

#### **Gain Set Stage**

The sawtooth waveform is applied to the grid of V72B and taken from the plate for application to the horizontal-deflection plate. DC coupled inverse feedback from plate to grid reduces the gain of this stage to approximately unity. R77, the SWEEP CAL control, permits the feedback to be varied over a small range so the overall gain of the horizontal amplifier can be set so the sawtooth waveform will sweep the crt spot the proper distance.

#### **Horizontal Positioning**

The HORIZ. POSITIONING control, R71, allows the dc level of the input grid of V72B to be varied thus changing the average dc

level of the plates of V72B and V80 which positions the trace to the left or right.

### **Phase-Inversion Stage**

V80 is a pentode amplifier with sufficient degenerative feedback from plate to grid to make the gain about equal to the gain of the first stage. The signal at the plate of V80 is out of phase with the signal at the grid and consequently out of phase with the signal applied to the crt pin-6 deflection plate so the single-ended input sawtooth is converted to a push-pull signal at the crt deflection plates.

### **HIGH-VOLTAGE SUPPLY**

Accelerating voltages for the crt are obtained by rectifying a 60-kc high ac voltage produced by a vacuum-tube oscillator. V104 is the oscillator tube connected as a Hartley oscillator with the primary of transformer T100 as the tapped inductor, and C107 as the capacitor.

A half-wave rectifier, V116, supplies about 1500 volts negative to provide the focus and accelerating voltages to operate the crt.

### **High-Voltage Regulator**

A portion of the rectified high voltage is tapped off at adjustable R132 and compared with the regulated -170 volt supply at V100A. Any error signal will be amplified and applied to the grid of V100B. The plate voltage of V100B determines the screen voltage of V104 and consequently the oscillator output. The feedback loop phasing is such that any change in the rectified high voltage will cause the oscillator output to change in the opposite direction thus cancelling variations in the high-voltage supply.

### **Unblanking**

The crt control-grid voltage is supplied by a separate secondary winding and rectifier. The positive end of this supply is connected to the +GATE INPUT binding post and a signal at this binding post will drive the whole grid-voltage supply with it so the same signal appears at the crt control grid about 1600 volts below. Since this is a dc connection,

the unblanking pulse can have any duration with no change in grid voltage. C116 transmits the leading edge of the unblanking pulse to reduce the unblanking time for fast sweeps.

### **Type 161**

The basic waveform generator of the TEKTRONIX Type 161 Pulse Generator is a plate-to-grid coupled monostable multivibrator, or "one-kick" multivibrator, coupled to the output terminals through suitable amplifiers, and triggered by means of a sharp negative pulse from a bistable multivibrator, or regenerative trigger amplifier.

### **Block Diagram Description**

In the Block diagram, V1 is a double triode whose two sections operate as a pulse amplifier when the instrument is being triggered by pulses, and as a voltage comparator when the instrument is being triggered by a sawtooth voltage. The voltage comparator circuit compares the amplified sawtooth with an adjustable comparison voltage and initiates a pulse when the two are equal. This arrangement provides an adjustable delay between the start of the sawtooth and the start of the pulse. The input switch, SW1, labeled POS. PULSE, NEG. SAWTOOTH, connects the input connector to the pulse amplifier in the POS. PULSE positions and rearranges the circuit into a voltage comparator in the NEG. SAWTOOTH positions.

The regenerative trigger amplifier, V2, produces a step of the same magnitude regardless of the size of the triggering pulse. The output step voltage of the trigger amplifier operates the monostable multivibrator consisting of V3B and V4A. The disconnect diode, V3A, couples the multivibrator to the trigger amplifier in the forward direction but prevents reaction of the multivibrator from affecting the trigger circuit.

Switch SW2, labeled PULSE WIDTH, selects any of four capacitors to vary pulse width.

The positive pulse amplifier, V4B, a cathode follower, provides positive output at the GATE OUT terminal and to the PULSE POLARITY switch SW3.

The negative pulse amplifier, V5 supplies negative output to the PULSE POLARITY switch SW3.

The PULSE AMPLITUDE potentiometer provides a continuous adjustment of the output pulse amplitude between 50 volts and zero.

### **Pulse Amplifier**

When the TRIGGER SELECTOR switch, SW1, is in the POS. PULSE position, the INPUT terminal is connected to the grid of V1B. Assuming that R9A, labeled POS TRIGGER BIAS, is set near 0.3 to give a bias voltage on V1B of about 80 volts, V1B will act as an amplifier to a positive pulse applied at the INPUT terminal, and a negative pulse will appear at its plate which is coupled to the grid of trigger amplifier, V2A. A 20-volt positive pulse into the INPUT terminals will produce a negative plate pulse of about 60 volts, which is transmitted through frequency-compensated divider, R10, R11, to the input grid of B section of V2.

### **Regenerative Trigger Amplifier**

The trigger amplifier is a bistable multivibrator which can be changed from complete cutoff of section A and full conduction of section B to the opposite condition of cutoff of section B and conduction of section A by a small input voltage variation of the order of 5 volts or less. The transition between one state and the other occurs very rapidly.

The circuit operation of the trigger circuit is briefly as follows: In the quiescent state, bias voltage at the grid of V2B is about 25 volts, slightly below cathode, so that some grid current flows and about 7 milliamperes of plate current flows. Bias voltage at the grid of A section of V2 is set well below cutoff by the voltage divider, R15, R16 connected between -170 volts and the plate of B section, which rests at about 75 volts because of plate current through R12.

When the B- section grid receives the negative spike of voltage from V1, its voltage begins to drop, and the plate voltage rises toward 225 volts. The plate of B section is connected

to the grid of A section through a frequency-compensated voltage divider, R15, R16, so that the A-section grid has a corresponding rise. Simultaneously, the common cathode voltage drops, and the grid and cathode of A section approach each other, so that plate current begins to flow in A section.

The grid of section A continues rapidly in the positive direction until sufficient cathode current flows through R13 to cause the cathode to rise above the grid of section B, and plate current from section B is then cut off, but section A conducts. The corresponding drop in plate voltage of section A causes a negative pulse of voltage to appear, which is differentiated through C5 and R17 to form a suitable negative spike to trigger the one-kick multivibrator.

After the input pulse into V1 has terminated and the grid voltage of this tube has dropped below about 75 volts, the plate of V1 then rises toward +225 volts carrying the grid of V2B with it, and the trigger circuit then returns to its quiescent state with the B section of V2 conducting while the grid of A section is biased well below cutoff. A positive pulse is generated at the plate of V2A at the instant of the transfer.

The negative spike out of the trigger tube, V2, is applied to the cathode of diode-connected V3A. In the quiescent state, V3B is cut off and the cathode and plate of V3A are therefore at the same voltage. A negative pulse at the cathode will thus be passed while a positive pulse will not. The unwanted positive pulse generated when the circuit returns to its quiescent state is therefore not applied to the one-kick multivibrator.

When the TRIGGER SELECTOR switch, SW1, is set to the NEG. SAWTOOTH position, the Type 161 will respond to a negative sawtooth waveform of sufficient amplitude. For this type of operation, V1 operates in a voltage-comparator circuit with the two cathodes connected to a common resistor. The cathode voltage required for conduction of section B is determined by a voltage-divider potentiometer, R9A, labeled OUTPUT PULSE DELAY, connected between ground and positive 225 volts, which sets the grid bias of V1B. The sawtooth signal input into section A of this tube must be dc connected to permit the instrument to operate at the low-frequency limit given in

the specifications, and must include an average dc component of about 80 volts.

At the start of the sawtooth input, V1A is conducting, and the cathode voltage follows within a few volts of the grid of V1A. When the cathode drops to a point within a few volts of the grid of section B, conduction begins in section B, causing a sudden drop in voltage at its plate and the resulting negative step triggers V2.

The calibration of potentiometer R9A is in terms of the fraction of the sawtooth waveform time duration at which triggering will result. The calibration is correctly set at the factory only for a negative-going sawtooth waveform, 130 volts peak to peak, between the limits of positive 150 volts and 20 volts. For waveforms not conforming to the foregoing, screwdriver adjustments R9B and R9C, labeled POS. DELAY LIMIT and NEG. DELAY LIMIT, must be readjusted to make the calibrations read correctly.

### **Monostable Multivibrator**

The one-kick multivibrator consists of section B of V3 and section A of V4. A one-kick multivibrator can be changed from conduction in one tube and cutoff at the other tube to the opposite condition upon application of a triggering pulse. Thereafter it returns to the original state by itself after a period of time determined by the sizes of circuit parameters.

In the quiescent state before receipt of the triggering pulse from the previously-described trigger circuit, plate current flows in V4A, and V3B is cut off. The grid of V4A is connected to a positive voltage near 150 volts through R24 which is of the order of 1 megohm. Grid current flowing through this resistor prevents the grid from going far positive. Grid current of the order of magnitude of 0.1 milliamp holds the grid voltage about half a volt positive, with a resulting plate current of about 8 milliamps, and the plate voltage rests at about 50 volts.

The grid voltage of V3B is determined at about -60 volts by the voltage divider R19, R22, connected between -170 volts and the plate voltage of V4A, about 50 volts, so that plate current of V3B is cut off.

A negative spike from the trigger circuit, coupled via one of the four timing capacitors, C6 to C9, depresses the grid of V4A to cutoff, resulting in a positive pulse of about 175 volts at the plate of V4A. The positive pulse is impressed on the grid of V3B through voltage-divider network R19, R22, causing plate current to flow momentarily until the timing capacitor charge is discharged through R24 and R25, and the grid of V4A rises sufficiently high to permit plate current to flow in V4A.

At the moment that plate current begins to flow in V4A, a negative step is generated at its plate which depresses the grid of V3B below cutoff and the multivibrator returns to its quiescent state. The length of the positive pulse out of V4B is determined by the size of the timing capacitor, the value of R24 plus R25, and the voltage into which the timing capacitor discharges, as determined by the setting of R26. The four timing capacitor values, C6 to C9, are in decade ratio to provide decade ratios of pulse widths, selectable by means of switch SW2, labeled PULSE WIDTH. R24, labeled PULSE WIDTH MULT., is variable and is fitted with an indicator dial calibrated from one to ten.

The resulting positive pulse from the plate of V4A is applied to the grid of output cathode-follower amplifier V4B by means of a frequency-compensated voltage divider, R30, R32, connected between the plate of V4A and minus 170 volts. During the quiescent state, V4B is biased well below cutoff at about 50 or 60 volts negative. The positive amplitude of the pulse applied to the grid of V4B is determined by the setting of R30, a screwdriver-adjustable potentiometer in the voltage-divider circuit, R30, R32. This level is adjusted at the factory so that the peak voltage at the GATE OUT terminal is 50 volts.

### **Negative Pulse Amplifier**

The positive pulse out of V4A is also applied to the grid of V5B through a frequency-compensated voltage divider consisting of R28 and R34. V5 is a dual triode with a common cathode resistor, R29, for both triode sections. In addition to receiving a positive signal on the grid of section B, V5 also receives a negative signal on the grid of section A, from the plate of V3B of the one-kick multivibrator.



In the quiescent state, the grid of V5B is about 18 volts below the grid of V5A, and V5B therefore has no plate current flowing. The common cathode potential is therefore determined by the current flowing through section A at a level a fraction of a volt below the grid of section A. When a negative pulse is impressed on the grid of section A, plate current in section A drops, thereby dropping the cathode potential.

When a positive pulse simultaneously impressed on the grid of section B raises its voltage within about nine volts of the cathode potential, plate current flows in section B. Because of the plate current flowing in section B, the cathode potential fails to fall as fast as the grid potential of section A and soon section A ceases to conduct while section B conducts heavily. A negative pulse is therefore developed at the plate of section B. The amplitude of the negative pulse into the output of the potentiometer is determined by the setting of R29, the variable cathode resistor. The PULSE POLARITY switch, SW3, inserts R31, a potentiometer, as the cathode-load resistor of V4B for positive-pulse output, or inserts it as the plate-load resistor for V5B for negative-pulse output. In the negative-pulse output position, a second section of SW3 inserts R33, as a cathode-load resistor in V4B to retain the positive gate output when SW3 is in the negative-pulse position.

### **Type 162**

The TEKTRONIX Type 162 Waveform Generator was designed primarily as an interval timer and repetition rate generator. The basic circuit element is a phantastron run-down circuit with timing capacitance and resistance values variable by means of front-panel selector switches, and provided with associated triggering circuits and wave shaping and output amplifiers.

### **Block Diagram Description**

The OPERATING MODE switch shown at the left of the diagram is in three sections. The section shown is the input section SW1C which, in the two top positions, completes the circuit from either the +GATE IN or the +TRIGGER IN panel connectors to the regenerative trigger tube, V1. In the remaining three positions,

SW1C grounds the grid of V1B, the input section of the regenerative trigger, so that its trigger action is not involved except in the top two positions of SW1C, labeled +GATE IN and +TRIGGER IN.

The regenerative trigger circuit, consisting of the two halves of V1, is a circuit which produces a large (80 volt) positive square-top voltage wave output for a small (8 volt) voltage change at its input. Upon receipt of a short voltage pulse, the trigger circuit produces a short output pulse. Upon receipt of a gating voltage, the output waveform remains positive until the input wave is removed.

The trigger amplifier, V2A, controls the operation of a multivibrator, V2B and V3A. Its grid and cathode circuits are switched by SW1A and SW1B switch sections in such a way as to cause it to produce either a short output pulse upon receipt of a grid signal, or to produce a gating signal for the duration of a signal input, depending upon the switch setting.

The multivibrator section, V2B and V3A, is triggered by a positive triggering voltage at the grid of V2A. The positive triggering voltage arises either by operation of the regenerative trigger, or by the grounding of the negative grid-bias source of V2A, depending upon the setting of the OPERATING MODE switch, SW1. The V3A half of the multivibrator gates the phantastron and permits it to run during the period of a positive pulse at V3A plate.

The phantastron section consists of V4, the pentode portion, V5B, a cathode-follower timing-capacitor recharged, and V6B, a diode-connected plate catcher, or plate-voltage limiter. The gating section of the multivibrator, V3A, during its period of plate-current conduction, holds the phantastron suppressor below the level that permits plate current conduction in the phantastron. During the period of the multivibrator cycle when V3A is not conducting, its plate voltage rises and carries the phantastron screen positive and the suppressor up to ground potential so as to initiate a phantastron rundown, and permit the phantastron to recycle continuously as long as this condition persists.

The length of time required for the phantastron to execute one rundown is determined by the discharging time of a timing capacitor and timing resistor. Switches SW3, labeled MULTIPLIER, and SW5, labeled WAVEFORM DURATION, select various values of timing capacitors and resistors to permit selection of the rundown time.

The panel connection labeled SAWTOOTH OUT, connects directly to cathode-follower V5B cathode to provide approximately a 1000-ohm output impedance. V5B thus serves the dual purpose of output tube and timing capacitor recharger.

Pulse and gate shaper, V3B, receives its input signal from the gating section of the multivibrator, V3A, which remains positive during the phantastron rundown. Toggle switch SW4, labeled PULSE OUT, GATE OUT, inserts either frequency-compensated dc coupling or differentiated ac coupling between the shaping amplifier and the output amplifier. In the GATE OUT position of SW4, dc coupling results.

In the output amplifier and cathode follower section, consisting of V5A, and V6A, the gate or pulse signal is amplified and limited, and the signal is produced across the cathode resistor of V6A at an impedance of about 1000 ohms. Cathode follower V6A is biased below cutoff before receiving a signal so that the output signal begins at ground potential and increases in the positive direction.

### Phantastron

In the quiescent state, the suppressor of V4 is held below plate-current cutoff at -40 volts by voltage divider R14, R15, connected between +40 volts at the plate of V3A and -170 volts, and V4 plate rests at +150 volts. The grid of V4 is connected to a positive voltage source through the variable timing resistance, R20, a high resistance of several megohms, so that grid current flowing in this resistor prevents the grid voltage from going more than a fraction of a volt positive. One end of timing capacitor C3 is connected to the grid of V4 and the potential of this end is therefore held at approximately ground voltage. The other end of timing capacitor C3 is connected to the cathode of cathode follower V5B whose grid is connected to the plate of V4, at +150 volts. The cathode

of a cathode follower adjusts its voltage by means of cathode resistor current to follow very close to the grid voltage. The cathode is therefore at positive 150 volts, and timing capacitor C3 is thus charged to 150 volts.

When a positive gating pulse is applied to the screen of V4, the suppressor rises to ground potential from -40 volts, plate current begins to flow in V4, and its plate voltage drops, carrying with it the grid and cathode of V5B. The grid voltage of V4 therefore drops momentarily because the low potential end of C3 is 150 volts below the cathode of V5B at the first instant, and C3 begins to discharge through R20. The rate of the discharge through R20 determines the voltage of the grid of V4, which in turn determines the plate voltage of V4. The sum of the cathode voltage of V5B and the voltage of the charge remaining on C3 must always be near but slightly lower than ground potential because the grid of V4 must be above plate current cutoff but below grid-current conduction. If, for example, the voltage at the cathode of V5B were momentarily to become too high with respect to charge voltage remaining on C3, the grid voltage of V4 would also rise, thus lowering V4 plate voltage and thereby the cathode voltage of V5B.

The discharge current from C3, flowing through R20, determines the grid voltage of V4. A change in voltage drop through R20, resulting from a change in discharge current from C3, will therefore be followed by a change in voltage at the cathode of V5B in the correct direction to oppose such a change in grid voltage of V4. For example, if C3 were simply to discharge through a resistor, the discharge current would fall off exponentially. However, the falling off of discharge current results in a decreasing drop in R20 and causes the grid of V4 to rise. Its plate then falls, dropping the voltage of the right end of C3 the required amount to increase the discharge current, and thus tends to maintain it at a constant value. With a constant discharge current flowing from timing capacitor C3, the voltage across C3 falls off linearly. Since the sum of the cathode voltage plus the voltage across C3 must remain near zero, it follows that the cathode voltage must also fall linearly.

When C3 is nearly discharged and the plate of V4 nears cathode potential, the cathode

current, which has been flowing largely through the plate, suddenly transfers to the screen, the screen voltage drops, carrying the suppressor with it, and thereby completely cuts off plate current from V4.

When plate current of V4 is cut off, the plate voltage of V4 rises immediately to plus 150 volts, carrying the grid, and eventually the cathode, of V5B with it. The grid of V4 is again held near ground potential by grid current and C3 charges rapidly to 150 volts through the low plate-to-cathode impedance of V5B. During the recharge period, the screen voltage drops as the result of screen current, carrying the suppressor with it by means of R14, so that plate current is further held off.

As the timing capacitor charges, the plate voltage of V4 increases until eventually it reaches a value such that the reduced suppressor voltage no longer prevents plate current from flowing. At this instant, cathode current begins to transfer from the screen to the plate, and the screen voltage rises, carrying the suppressor with it, which further increases the plate current. The plate voltage then drops, C3 begins to discharge, and the rundown action starts again. However, if V3A is conducting, the suppressor of V4 is held below cutoff when the plate of V4 reaches full 150-volt plate voltage and the phantastron therefore returns to its quiescent state at the finish of one rundown.

### Gating Multivibrator

The gating function is performed by V3A, which, with V2B, forms an Eccles-Jordan multivibrator connected so that in the quiescent state V3A is conducting and the screen and suppressor voltages of the phantastron tube V4 are reduced below the point of plate current cutoff. To permit V4 to start its rundown action, the multivibrator must be in the opposite state with V3A not conducting and V2B conducting. In the quiescent state, voltage at the grid of V3A is limited to a fraction of a volt positive and V3A conducts. A negative pulse at the plate of V2B will momentarily drive the grid of V3A negative below cutoff through R17 and the plate of V3A will rise rapidly, carrying the screen and suppressor of phantastron V4 with it, thereby initiating the phantastron rundown action.

At the termination of the rundown period, a sudden drop in screen voltage of phantastron, V4, drives the grid of V2B down, a positive step results at the plate of V2B which raises the grid of V3A into the conducting region again, and the screen and suppressor voltages of V4 are lowered below the point of plate current conduction so that the quiescent state is resumed.

### Trigger Amplifier

The grid of trigger amplifier V2A is connected to the arm of OPERATING MODE switch section SW1A. In the GATED or TRIGGERED positions of this switch, the instrument is prepared to receive external trigger pulses. In the quiescent state before receipt of a pulse, the grid of V2A is held below plate current cutoff at -20 volts, by low plate voltage of V1A, and V2B grid is held below cutoff by low plate voltage at V3A.

Upon receipt of a large positive step of voltage at its grid, V2A begins to conduct and a negative step appears at its plate.

In the GATED position, the cathode of V2A is grounded, its grid is limited to a fraction of a volt positive by grid current through R10, and the plate of V2A drops about 200 volts because of plate current of about 4 milliamperes, and carries the grid of V3A well below plate current cutoff. The plate of V3A therefore rises and permits the phantastron action to commence.

When the OPERATING MODE switch, SW1, is in the TRIGGERED position, the cathode of V2A is returned to ground through R30 and C6, a parallel differentiating network with a time constant sufficiently short that V3A is held off from conduction only long enough to start one phantastron rundown for each positive impulse received.

When the OPERATING MODE switch, SW1, is in the RECURRENT position, the grid of V1B is grounded and the grid and cathode of V2A are grounded so that V3A is held off from conduction as long as the switch remains in this position. The phantastron will operate recurrently, therefore.

When the OPERATING MODE switch, SW1, is in the MAN CONT position, the grid of V1B and cathode of V2A are grounded. The grid of V2A is held below plate current cutoff by voltage divider R9, R10, and R11. Pushbutton SW2, labeled MANUAL, when depressed, raises the grid-to-ground potential and causes plate current to flow, thereby raising the plate of V3A. The phantastron therefore runs recurrently as long as the pushbutton remains depressed.

When the OPERATING MODE switch, SW1, is in the MAN, ONE CYCLE position, V1B grid is grounded and the cathode of V2A is returned to ground through parallel differentiating network, R32, C6, whose time constant is shorter than the rundown time of the phantastron. The phantastron therefore executes only a single rundown each time the pushbutton is depressed.

### **Regenerative Trigger**

When the OPERATING MODE switch, SW1, is in either the GATED or TRIGGERED positions, the grid of V1B is connected to receive external voltage pulses through the appropriate panel connectors, labeled +GATE IN and +TRIGGER IN.

In the quiescent state the grid of V1A rests at about 17 volts. Under these conditions about 6 milliamperes of plate current flows in V1A, resulting in a cathode voltage of about 20.5 volts, and a plate voltage of about 135 volts. The center point of voltage divider R10, R11 connected between V1A plate and -170 volts is therefore about -20 volts in the quiescent state.

The cathode of V1A and V1B are tied together so that V1B also has a cathode bias of +20.5 volts. The grid of V1B is returned to ground through R4 and plate current flowing in V1B is about one-tenth milliamperere.

A positive step of voltage arriving at the grid of V1B causes V1B plate to drop, carrying the grid of V1A with it through network, C10, R6, thereby reducing the cathode current of V1A. This causes the common cathode voltage of V1A and V1B to drop, further increasing the grid-to-cathode voltage of V1B so that the action is regenerative. The plate of V1A rises rapidly toward +225 volts with a positive

step at this point of 80 volts or so, as the plate current in this section reduces almost to zero.

The center point of voltage divider R10, R11, which has been about 20 volts negative, is therefore driven positive about 40 volts to +20 volts, carrying with it the grid of V2A, the trigger amplifier tube.

When the OPERATING MODE switch is in the GATED position, the +GATE input terminal is directly connected to the grid of V1B so that a positive gate signal applied to the terminal raises the grid voltage and holds it during the time the gate signal persists. When the OPERATING MODE switch is in the TRIGGERED position, however, a step voltage applied to the +TRIGGER terminal is ac coupled through C2 and R4, so that V1B grid will return to ground potential after C2 is charged, and the regenerative trigger circuit will return to its quiescent state.

### **Pulse and Gate Shaper and Output Amplifier**

The gate and pulse waveform shaper, V3B, is followed by a two-stage amplifier and cathode-follower combination, consisting of V3B, V5A, and V6A. The grid of V3B is connected via R14, R15, to the plate of V3A, the gating section of the multivibrator, and hence is driven from -40 volts to zero bias each time rundown occurs. This results in a negative squarewave of output from the plate of V3B. When the toggle switch, SW4, is in the GATE OUT position, an over-compensated negative pulse appears at the grid of V5A. This results in cut off of V5A during the phantastron rundown, and a positive squarewave is therefore produced at its plate. The plate of V5A is directly coupled to the grid of cathode follower, V6A, which, in its quiescent state, is cut off, so that a positive gate results, starting at ground potential and going positive approximately 50 or 60 volts. When the toggle switch, SW4, is in the PULSE OUT position, the coupling capacitor, C3A-F, acts as a differentiating capacitor. This produces a negative spike on the grid of V5A and results in a rather narrow positive pulse at the plate of V5A. The amplitude of the pulse is the same as that of the gate but the pulse is considerably narrower. The differentiating capacitor, C3A-F, is switched with the sweep-timing capacitor,

C3B-G, so that the pulse width is a function of the pulse interval. This provision helps to keep the pulses more readily visible at the lower repetition rates when they are displayed on an oscilloscope.

### **Type 163**

The basic waveform generator of the TEKTRONIX Type 163 Pulse Generator is a monostable, or "one kick" multivibrator, triggered by sharp pulses from a regenerative trigger amplifier. A voltage-comparator circuit permits triggers to be generated at any point on an input sawtooth voltage to provide adjustable delay. An output cathode follower provides low output impedance.

### **Block Diagram**

The Block Diagram shows the INPUT switch in the position to accept sawtooth triggering pulses.

The sawtooth-comparator circuit compares the input sawtooth with an adjustable comparison voltage, and initiates a voltage step when the two are equal.

The output step voltage from the comparator is formed into a sharp trigger of the desired amplitude regardless of the size or slope of the triggering pulse by means of the regenerative trigger amplifier. The regenerated negative pulse is coupled through the disconnect diode to the plate of the multivibrator.

The negative pulse into the multivibrator causes it to flop from its stable state to its unstable state. The period of time the multivibrator remains in its unstable state determines the width of the output pulse. This period depends on the size of the switched capacitor and the size of variable resistors through which the capacitor discharges.

The charging diode speeds the transition period of the multivibrator back to the stable state at the conclusion of the unstable period.

The cathode follower reduces the output impedance to reduce effects of the external load characteristics on the pulse shape.

When the INPUT selector switch is in the POSITIVE PULSE position, the operation is the same in all circuits except the input tube, which in this switch position becomes a simple amplifier.

### **Input Selector Switch**

The input selector switch, SW10, connects the grid of V10B to the INPUT terminal in NEG. SAWTOOTH position, and in the POS. PULSE position connects the grid of V10A to the INPUT terminal through a capacitor, while connecting the unused grid of V10B to a positive voltage on voltage divider R10, R11, connected between +225 volts and -170 volts.

### **Sawtooth Comparator**

The grid voltage of V10A is determined by the setting of R21, which is part of a voltage divider consisting of R20, R21, and R22. When the required sawtooth voltage at the grid of V10B is above this voltage, the common cathode voltage closely follows V10B grid as it drops and is more positive than V10A grid, so that V10A is cut off. When the common cathode voltage approaches V10A grid, current suddenly begins to flow in V10A and a negative voltage step appears at V10A plate. Between its two voltage limits, potentiometer R21 can change the bias by more than 100 volts, and can therefore cause the voltage step to occur at any point of the sawtooth within this range.

### **Regenerative Trigger Amplifier**

The negative step is transmitted to the grid of V11B through frequency-compensated voltage divider C23, R23, to the grid of V11B. C23 is the compensating capacitor which transmits the higher frequency components of the negative step voltage.

V11 is a bistable regenerative trigger amplifier. In the quiescent state before receipt of the negative step voltage V11B is conducting and V11A is cut off because the common cathode connection is at a higher voltage than the grid of V11A. When the negative step arrives at the grid of V11B the common cathode voltage drops while V11B plate rises, and

the grid of V11A, which rises with the plate of V11B, approaches the falling cathode until conduction occurs in V11A. As soon as conduction does occur in V11A a rapid transition takes place, with the current transferring from the B section to the A section, and the attendant rise of B-section plate drives the A-section grid farther positive.

A second stable state is reached when V11B no longer conducts at all and the A-section plate remains down. This new stable state continues as long as the plate of V10A is down low enough to hold off plate current from V11B, regardless of how much farther it falls below this point. The change in plate voltage of V11A is thus determined only by the circuit constants of V11A, and a uniform negative step voltage is obtained regardless of the size or speed of the triggering voltage.

### Multivibrator

V13 and V14 comprise a monostable multivibrator. In the stable state V14 is conducting with its grid at ground voltage and its cathode slightly above ground. The grid of V13 is held somewhat negative by the setting of potentiometer R42.

The negative pulse from regenerative pulse amplifier V11 coupled through disconnect diode V12A to the plate of the multivibrator forces the plate of V13 and grid of V14 in the negative directions. As the grid of V14 drops, the common-cathode voltage drops below the grid voltage of V13, thereby causing plate current to flow and further reducing V13 plate. Since the reduction of current in V14 and increase in current in V13 is regenerative, the transition takes place very rapidly.

In the quiescent state, one end of C54 is at ground potential since there is no current flowing through R50 and R51. The other end of C54 is at +225 volts since there is no current flowing in R40, and there is thus a 225-volt charge on C54.

When the multivibrator is triggered, the plate of V13 drops so that the end of C54 formerly grounded is driven negative. This carries the grid of V14 with it past cutoff to well below ground, and C54 begins to discharge through R50 and R51. The length of time required

for this end of C54 to rise to ground potential depends on the size of R50 and R51, through which the discharge current flows, and on the size of C54. R51 is adjustable by means of a front-panel control labeled PULSE WIDTH MULTIPLIER, and C54 is one of four switched capacitors, C50-C51, C52, C53 and C54, so that the discharge time can be adjusted over a 10,000-to-1 range by selecting capacitors and adjusting the resistor.

As soon as the selected capacitor has discharged until the grid of V14 is again near its cathode, current again flows in V14, the cathode rises because of increased cathode current, the plate of V13 rises carrying V14 grid with it and further increasing current through V14 until the original stable state is resumed with V13 cut off.

In the stable state while V14 is conducting its plate rests in the vicinity of +140 volts because of plate current flowing through R48. During the period while V14 is cut off its plate rises to +225 volts and therefore a square-topped positive pulse of about 85 volts peak-to-peak amplitude is produced.

### Output Cathode Follower

The positive pulse is dc coupled to the grid of output cathode-follower V15 through compensated voltage-divider R62, R63 which is returned to an adjustable negative voltage. This divider places the grid of V15 below cutoff during the stable period of multivibrator V14, and raises it into conduction when V14 plate rises during cutoff to +225 volts. The amount of voltage division is designed by selection of R62 and R63 to place the grid of V15 near 25 volts positive when V14 plate is cut off. The voltage to which the negative end of the voltage divider is returned can be adjusted by means of R61, labeled PULSE AMP CAL so that the peak of the output pulse at the cathode of V15 is 25 volts positive. The output impedance at the gate terminal is approximately 100 ohms and the output impedance at the pulse terminal varies between about 500 ohms and zero, depending on the PULSE AMPLITUDE potentiometer setting. The maximum impedance occurs at about the 13-volt setting.

### **Disconnect Diode**

V12A, the disconnect diode between the regenerative trigger amplifier and the multivibrator is provided to disconnect the multivibrator from the trigger amplifier after the multivibrator has been triggered to its unstable state, so that subsequent trigger signals will not affect the multivibrator until it has again reverted to its stable state. In the stable state when the plate of both V11A and V13 are cut off and rest at +225 volts, a negative pulse at the cathode of the disconnect diode will tend to pull the plate down with it, and thus transmit the pulse to the multivibrator. After the multivibrator is triggered the plate of V13 drops well below the plate of V11A and trigger-size variations of V12A cathode have no effect on V12A plate.

### **Charging Diode**

Charging diode V12B from the grid of multi-

vibrator V14 to ground provides a low-resistance charging path to ground for C53, so that V13 plate can rise more rapidly when the multivibrator returns to its stable state.

### **Power Connector**

The octal plug and socket shown on the upper left of the circuit diagram consist of male and female chassis-mounted connectors to fit the interunit cables supplied with the instrument to connect the Type 163 to a Type 160A Power Supply. The female connector permits additional Type 161, Type 162 or Type 163 units to be operated from the same Type 160 Power Supply. R6 in the wiring between power connectors connects the unregulated 300 volts to the regulated 225-volt bus to increase the available current for the Type 163.





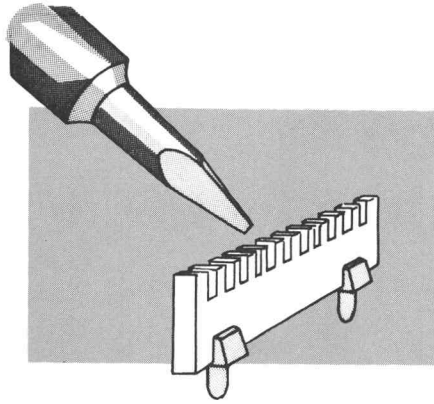

## SECTION 4

# MAINTENANCE

### Standard Components

Tektronix will supply replacement components at current net prices. However, since most of the components are standard electronic and radio parts you can probably obtain them locally faster than they can be shipped from the Tektronix factory at Beaverton, Oregon. Before ordering replacement parts be sure to consult the instruction manual to see what tolerances are required.

### Selected Components

We specially select some of the components whose values must fall within prescribed limits, by sorting through our regular stocks. The components so selected will have standard RETMA color coding showing the value and tolerance of the stock they were selected from, but they will not in general be replaceable from dealer's stocks.

### Checked Tubes

To obtain maximum reliability and performance we check some of the vacuum tubes in our instruments for such characteristics as microphonics, balance, transconductance, etc. We age other tubes to stabilize their characteristics. Since there are no well defined standards of tube performance we have established our own arbitrary standards and have developed equipment to do this checking. These checked tubes can be purchased through our local Field Engineering Offices or directly from the factory in Beaverton, Oregon.

### HOW TO ORDER PARTS

Replacement parts may be purchased at current net prices from your local Tektronix Field Office or from the factory. Most of the parts can be obtained locally. All of the structural parts, and those parts noted in the parts list "Manufactured by Tektronix", should be ordered from Tektronix.

When ordering from Tektronix include a complete description of the part, and its 6-digit part number. Give the type, serial number, and modification number (if any) of the instrument for which it is ordered.

Structural parts are not listed in the parts list. Their part numbers are usually stamped directly on the metal. If not, a complete physical description of the part will suffice.

If the part which you have ordered has been replaced by a new or improved part, the new part will be shipped instead. Tektronix Field Engineers are informed of such changes. Where necessary replacement information comes with new parts.

### NOTE

Always include the instrument TYPE and SERIAL NUMBER in any correspondence concerning this instrument.

### GENERAL INFORMATION

#### Color Coding

We use color-coded wires in the instruments to help identify the various circuits. These wires will be either a solid color or will be

a solid color (including black and white) with one or more colored stripes. The colored stripes are "read" in the same manner as the RETMA resistor color code. In the case of multiple stripes the wide stripe is read first.

Wires carrying positive regulated-power-supply voltages are white and the stripes indicate the supply voltage. For example, the +225-volt supply bus will be coded red-red-brown (2-2-1) giving two significant figures and the decimal multiplier.

The negative-supply bus wires are black and the stripes indicate the supply voltage. For example, the negative-supply voltage is -170-volt and is carried by a black wire coded brown-violet-brown (1-7-1).

The main-voltage leads to the power transformer are yellow and coded brown-brown-brown (1-1-1).

The tube heater leads are white and coded 6-1, 6-2, 6-3, etc., not to indicate that the voltages are different but to differentiate between circuits.

In other respects the color coding will vary from instrument to instrument. In general all signal-carrying leads are white and coded with a single colored stripe. In a few places where the number of leads exceeded the capabilities of single-stripe coding we have used solid-color leads.

## SOLDERING AND CERAMIC STRIPS

Many of the components in your Tektronix instrument are mounted on ceramic terminal strips. The notches in these strips are lined with a silver alloy. Repeated use of excessive heat, or use of ordinary tin-lead solder will break down the silver-to-ceramic bond. Occasional use of tin-lead solder will not break the bond if excessive heat is not applied.

If you are responsible for the maintenance of a large number of Tektronix instruments, or if you contemplate frequent parts changes, we recommend that you keep on hand a stock of solder containing about 3% silver. This type of solder is used frequently in printed circuitry and should be readily available from

radio-supply houses. If you prefer, you can order the solder directly from Tektronix in one-pound rolls. Order by Tektronix part number 251-514.

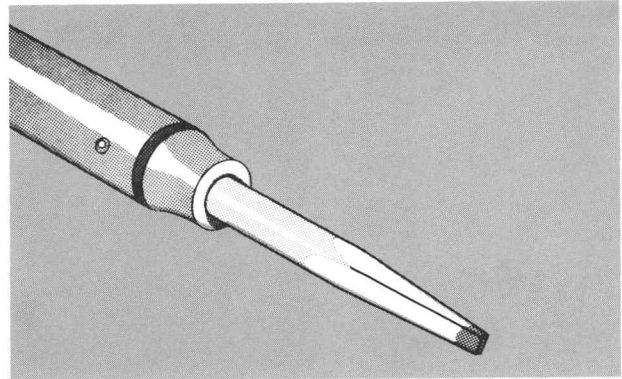

Fig. 4-1. Soldering iron tip correctly shaped and tinned.

Because of the shape of the terminals on the ceramic strips it is advisable to use a wedge-shaped tip on your soldering iron when you are installing or removing parts from the strips. Fig. 4-1 will show you the correct shape for the tip of the soldering iron. Be sure and file smooth all surfaces of the iron which will be tinned. This prevents solder from building up on rough spots where it will quickly oxidize.

When removing or replacing components mounted on the ceramic strips you will find that satisfactory results are obtained if you proceed in the manner outlined below.

1. Use a soldering iron of about 75-watt rating.
2. Prepare the tip of the iron as shown in Fig. 4-1.
3. Tin only the first 1/16 to 1/8 inch of the tip. For soldering to ceramic terminal strips, tin the iron with solder containing about 3% silver.

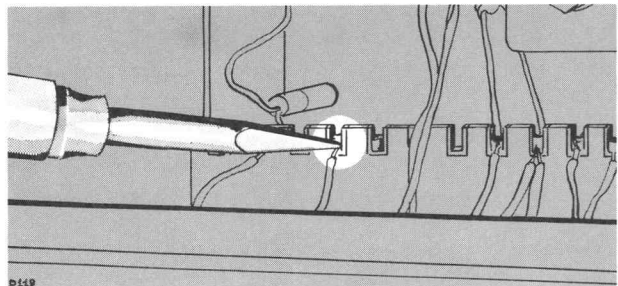

Fig. 4-2. Method of applying heat to ceramic strip.

4. Apply one corner of the tip to the notch where you wish to solder (see Fig. 4-2).

5. Apply only enough heat to make the solder flow freely.

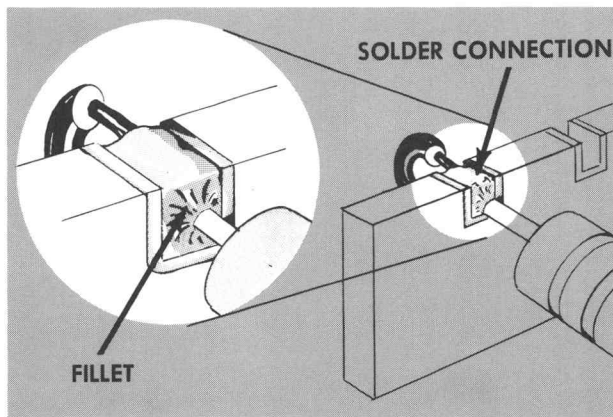

Fig. 4-3. Note the slight fillet formed on a correctly soldered joint.

6. Do not attempt to fill the notch on the strip with solder; instead, apply only enough solder to cover the wires adequately, and to form a slight fillet on the wire as shown in Fig. 4-3.

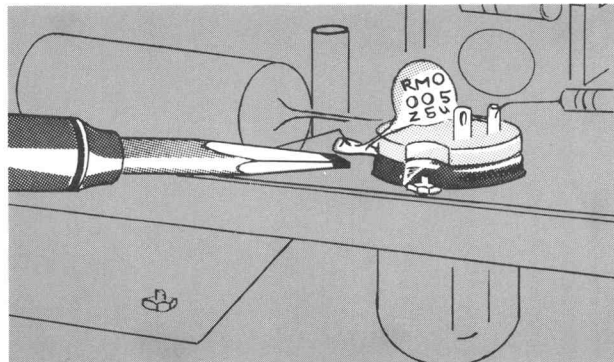

Fig. 4-4. Soldering to a metal pin.

In soldering to metal terminals (for example, pins on a tube socket) a slightly different technique should be employed. Prepare the iron as outlined above, but tin with ordinary tin-lead solder. Apply the iron to the part to be soldered as shown in Fig. 4-4. Use only enough heat to allow the solder to flow freely along the wire so that a slight fillet will be formed as shown in Fig. 4-3.

### General Soldering Considerations

When replacing wires in terminal slots clip the ends neatly as close to the solder joint

as possible. In clipping the ends of wires take care the end removed does not fly across the room as it is clipped.

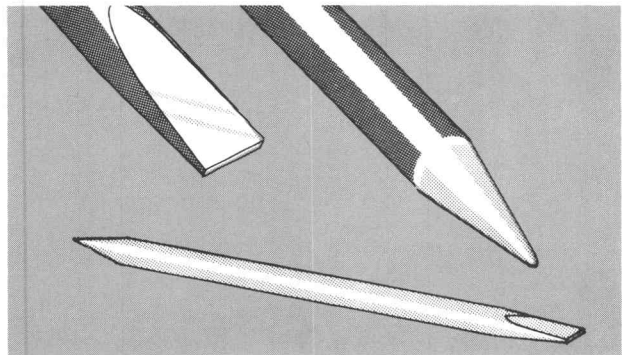

Fig. 4-5. A wooden dowel shaped for use as a soldering aid.

Occasionally you will wish to hold a bare wire in place as it is being soldered. A handy device for this purpose is a short length of wooden dowel, with one end shaped as shown in Fig. 4-5. In soldering to terminal pins mounted in plastic rods it is necessary to use some form of "heat sink" to avoid melting the plastic. A pair of long-nosed pliers (see Fig. 4-6) makes a convenient tool for this purpose.

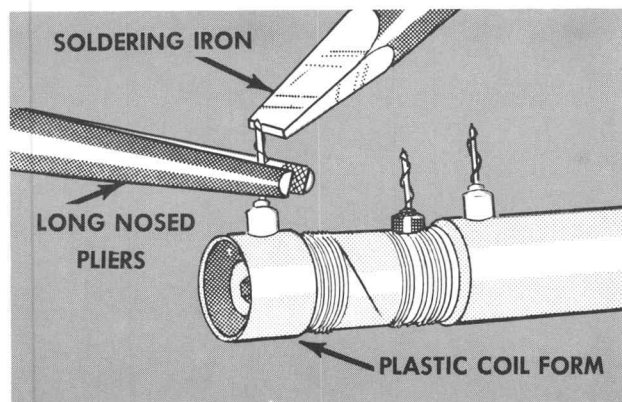

Fig. 4-6. Long-nosed pliers used as a heat sink.

### Ceramic Strips

Two distinct types of ceramic strips have been used in Tektronix instruments. The earlier type mounted on the chassis by means of #4-40 bolts and nuts. The later type is mounted with snap-in, plastic fittings. Both styles are shown in Fig. 4-7.

To replace ceramic strips which bolt to the chassis, screw a 2-56 nut onto each mounting bolt, positioning the nut so that the distance between the bottom of the nut and the bottom

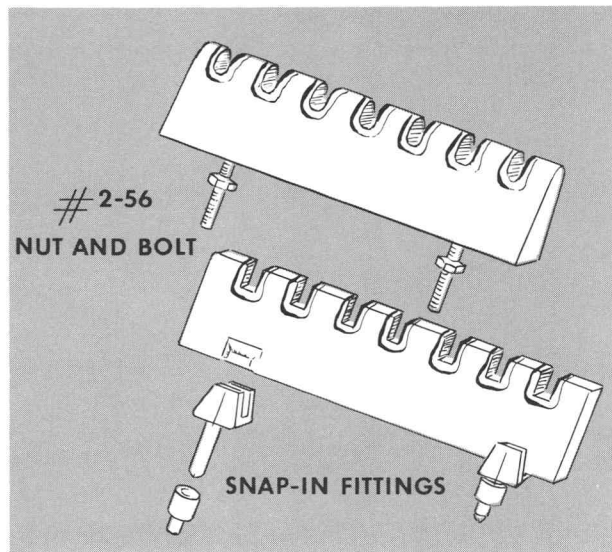

Fig. 4-7. Old and new styles of ceramic strips. The newer ceramic strips mount in nylon collars.

of the ceramic strip equals the height at which you wish to mount the strip above the chassis. Secure the nuts to the bolts with a drop of red glyptal. Insert the bolts through the holes in the chassis where the original strip was mounted, placing a 2 star lockwasher between each nut and the chassis. Place a second set of 2 flat washers on the protruding ends of the bolts, and fasten them firmly with another set of 2-56 nuts. Place a drop of red glyptal over each of the second set of nuts after fastening.

### Mounting Later Ceramic Strips

To replace ceramic strips which mount with snap-in plastic fittings, first remove the original fittings from the chassis. Assemble the mounting post on the ceramic strip. Insert the nylon collar into the mounting holes in the chassis. Carefully force the mounting posts into the nylon collars. Snip off the portion of the mounting post which protrudes below the nylon collar on the reverse side of the chassis.

#### NOTE

Considerable force may be necessary to push the mounting rods into the nylon collars. Be sure that you apply this force to that area of the ceramic strip directly above the mounting rods.

## TROUBLESHOOTING

The 160-Series instruments are relatively troublefree. You should not experience much need for extensive troubleshooting. In troubleshooting, however, you should remember that these are complex electronic instruments, and there is no easy way to locate trouble. A thorough understanding of circuit operation is the best aid in troubleshooting.

The first step in troubleshooting the 160-Series instruments should be to determine whether the input voltages at the octal power socket are correct. Refer to the schematic diagram for the instrument to determine the connections. If the voltages are incorrect remove the plug from the power socket to determine whether the trouble is in the power supply or in the Pulse Generator unit. If the trouble appears to be in the Pulse Generator look for evidence of overheated components. If no burned or blackened parts are in evidence try replacing all the tubes at once with new tubes. If replacement of all the tubes cures the trouble, you can then return the original tubes to their sockets one at a time until the defective tube is located.

Failure of the instrument to operate correctly will probably be due to tube deterioration than from component failure. The pulse generator circuits are relatively insensitive to minor tube variations, but relatively more sensitive to power-supply voltages.

## CALIBRATION EQUIPMENT

In calibrating the 160-Series instruments two auxiliary generators are required: a Type 105 Square-Wave Generator and a Type 180A or Type 181 Time-Mark Generator. The pertinent specifications for these two instruments are listed below.

Type 105:

Risetime: Less than  $0.02 \mu\text{sec}$  into a terminated 93-ohm cable.

Frequency Range: 25 cycles to 1 mc, continuously variable.

Maximum Output: 15 v, approximately into a terminated 93-ohm cable.

Type 180A: or Type 181:

Time-Marks: 1, 10, 100, 1000, and 10,000 microseconds.

Marker Amplitude: minimum 2 volts.

## Trouble Shooting

### Type 126

Tube failure will be the principal cause of trouble involving high or low voltage, lack of regulation or absence of any voltage. Low emission in the rectifiers or series tubes

may cause the supplies to drop out of regulation. Since the other supplies are referenced to the -170-volt bus, check this supply first. Remove or measure all external loads to determine whether the trouble lies elsewhere.

If there is no voltage at any terminal, check the source of power and check the fuse. If a replacement fuse should blow look for shorted tubes. Try replacing the rectifiers and the series regulators. If this clears the trouble, the offending tube can be found by replacing the old tubes one at a time. If tube replacement does not clear the trouble, lift the leads of the electrolytics, C118 and C120. If this clears the trouble, the shorted capacitor can be found by replacing the leads one at a time.

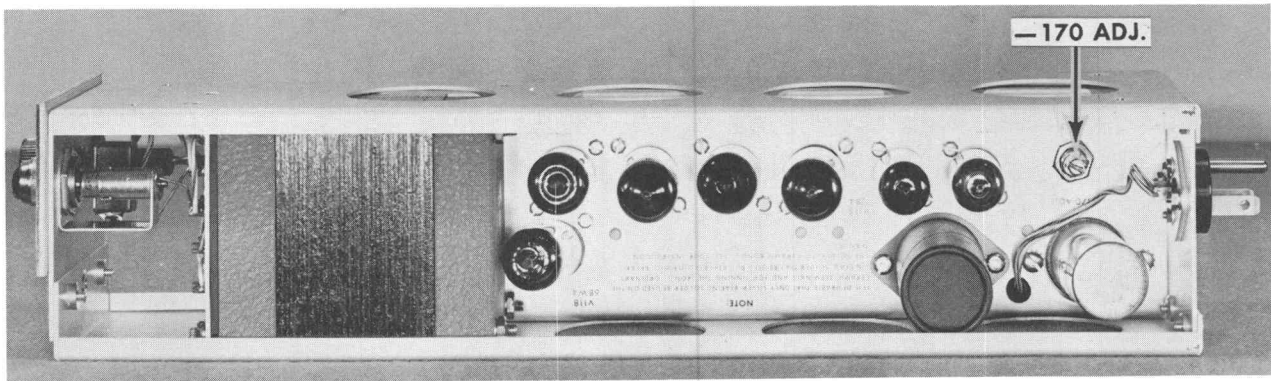

Fig. 4-8. Bottom view of the Type 126 power supply.

## Adjustment

The only adjustment necessary in the power supply is the adjustment of the -170-volt supply. R117, labeled -170 ADJ, accessible from the

left side of the instrument near the back adjusts this supply. No other adjustments are provided. If the other regulated voltages are incorrect after the negative supply is set, check for weak tubes or defective resistors in the voltage dividers.

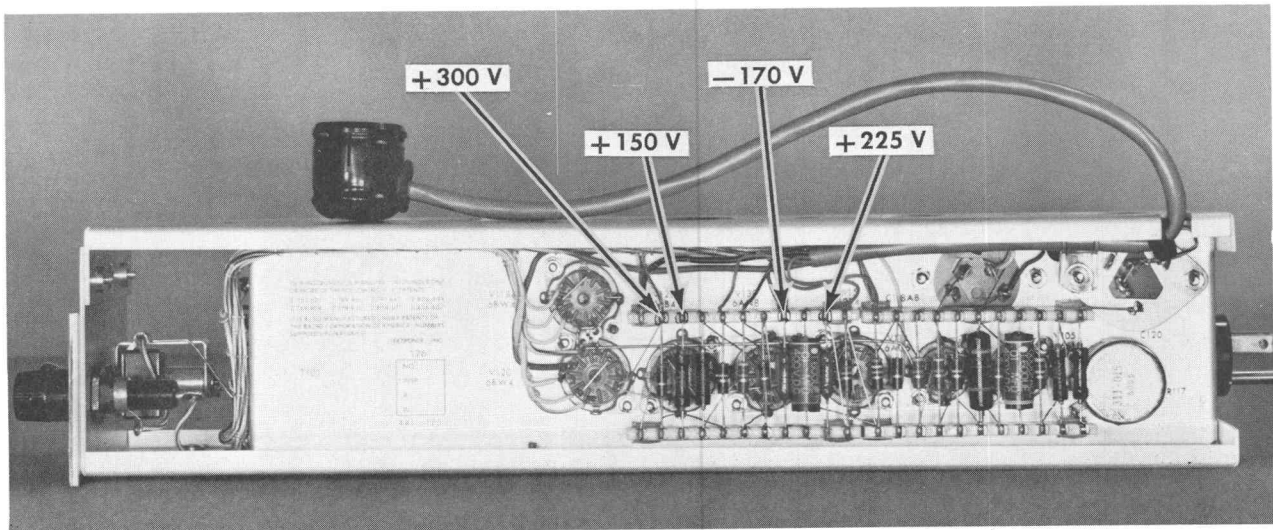

Fig. 4-9. Type 126, Top view.

## Type 160

### Maintenance

The following may help in determining the cause of equipment trouble. All components are conservatively loaded and the minimum of trouble should be expected. Tube failure will be the principal cause of trouble involving high or low voltage, or absence of any voltage. Low emission in either V2 or V3B may reduce the voltage below ground at the -170-volt bus. This will increase the voltage of both the +225-volt and +150-volt supplies. Low emission of V1 or V3A may lower both these voltages. Remove all external loads from the power supply to determine whether the trouble lies elsewhere.

In case of absence of voltage at all terminals, check whether the power cord is firmly seated and check the 3-amp fuse mounted on the lower part of the front panel. A simple method of checking the fuse is to replace it with a good one. If a replacement fuse should blow look for shorted tubes by replacing them all. If this procedure clears the trouble, the offending tube can be found by replacing the old tubes one

at a time. If tube replacement does not clear the trouble, lift the ungrounded lead of each of the four capacitors, C1, C2, C5 and C6. If this clears the trouble, the offending capacitor can be determined by replacing the leads one at a time.

### Adjustment

If readjustment of the regulated voltages is required, the negative 170-volt supply should be checked and adjusted first because this bus is used as the reference for both the +225- and +150-volt supplies. R15A, labeled ADJ TO -170V, located on the top of the chassis to the rear, a screwdriver adjustment, controls the -170-volt bus. R5A, labeled ADJ. TO +225V, also located on the top of the chassis to the rear, controls the +225-volt bus. No adjustment for the 150-volt bus is provided. If this voltage departs far from 150 volts because of deterioration of circuit elements and other voltages are normal, it may be necessary to replace the resistors in the voltage-determining network to return the voltage to normal. Voltage divider R9, R10 which determines the bias voltage of V7A is the voltage-determining network.

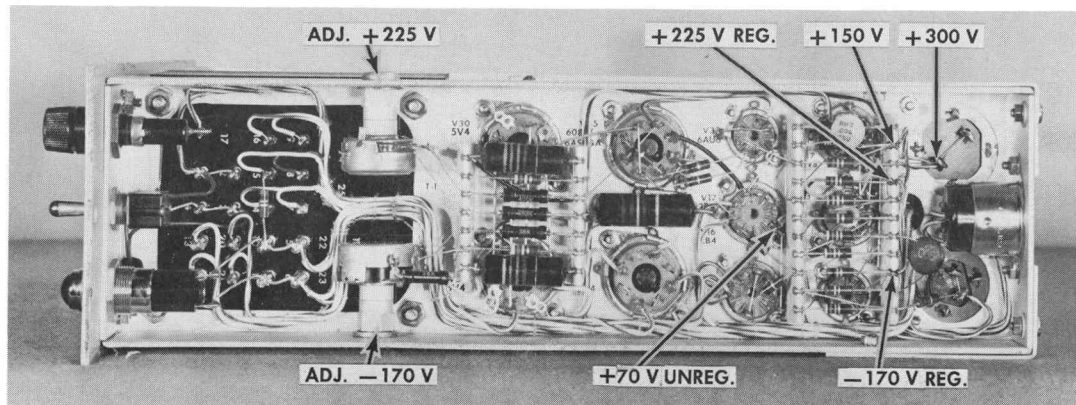

Fig. 4-10. Bottom view of the Type 160 showing the location of the adjustment points.

## Type 360

Before going thru the calibration procedure be sure the other instruments used with the indicator are operating normally--especially the power supply. A quick check of the power-supply voltages to see that they are within specifications might save much time as these voltages affect the calibration of the entire instrument.

Remove the case from the instrument and plug it and the Type 162 into the power supply. Turn the instruments on and allow them to operate for about five minutes until the initial warm-up drift has ceased.

### General

The following outline is based on the procedure used in our test department here at the factory.

Some of the adjustments require the use of a square-wave generator and a time-mark generator. Almost any accurate frequency generator can be used in place of a time-mark generator, however, the use of the square-wave generator is almost mandatory. If you do not have a square-wave or pulse generator with a rise-time of 1 microsecond or less do not attempt to adjust the vertical attenuators. This adjustment is quite stable and should not vary appreciably from its original adjustment.

### Sweep Timing

There are two adjustments that will affect the sweep timing. Varying the crt accelerating voltage will change the deflection plate sensitivities and have a large effect on the length of the horizontal display. The SWEEP CAL. control on the front panel changes the gain

of the horizontal amplifier and has a lesser effect on the horizontal display. Change the crt high voltage to make a coarse adjustment and use the SWEEP CAL. control for a final fine adjustment.

1. Set the 162 for a 1-msec sawtooth which is 100  $\mu$ sec per division on the 360 graticule. Connect the 100- $\mu$ sec output of a Type 180A or 181 Time-Mark Generator to the 360 VERTICAL INPUT and trigger the 162 from the 180A trigger output or the 181 1000- $\mu$ sec output.

2. Center the 360 SWEEP CAL control and adjust the high voltage so the timing marks very nearly coincide with the graticule lines over the center 8 divisions of the graticule. The HV ADJ control can be reached with a screwdriver through a cutout in the shield at the lower left side and to the rear of the instrument.

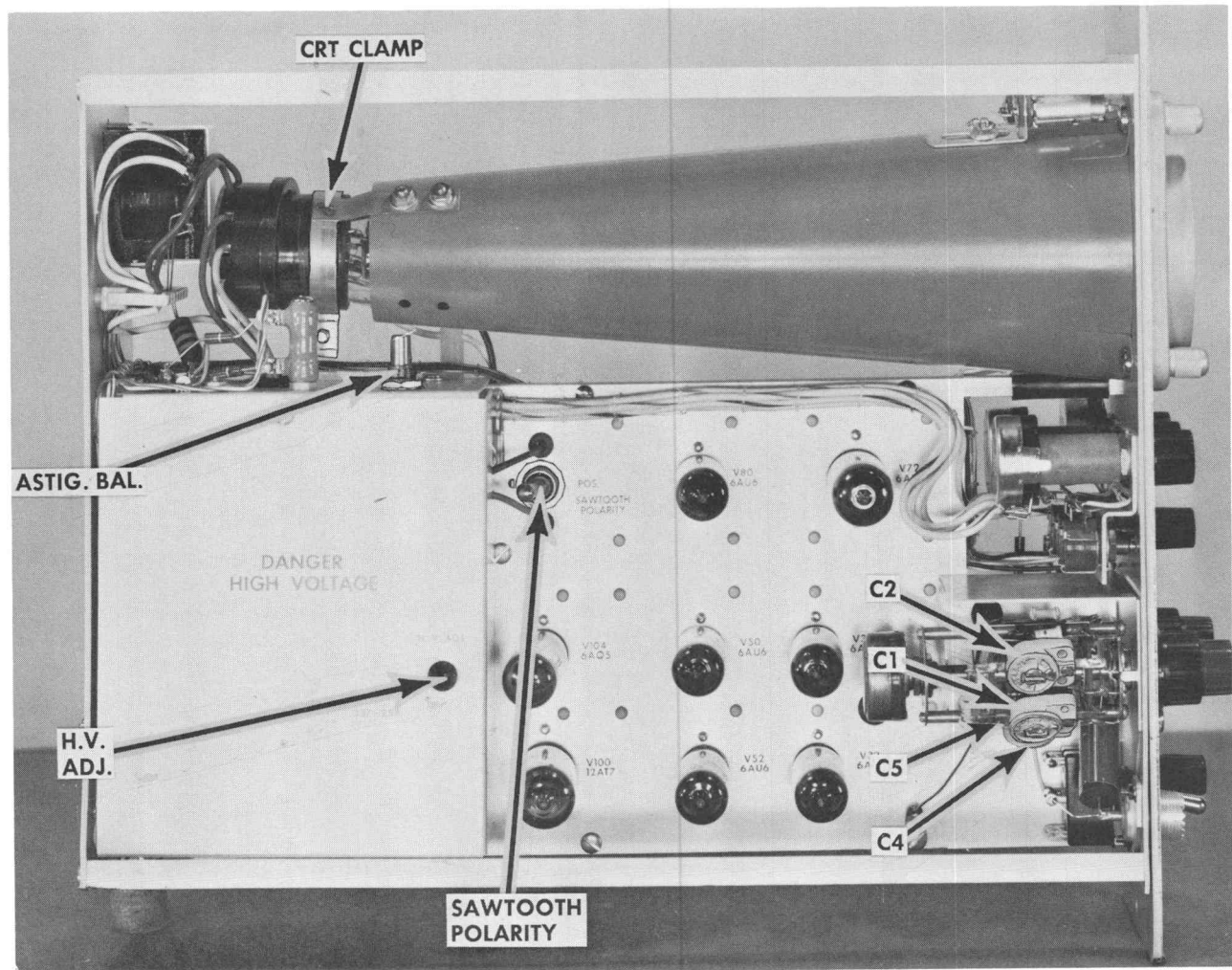

Fig. 4-11. Side view of the Type 360 Indicator Unit.

3. Use the SWEEP CAL control to make any final fine adjustment to achieve the best coincidence between the graticule lines and the timing marks.

## VERTICAL AMPLIFIER

There are three adjustments to be made to the vertical amplifier. First, to standardize the gain so that volts of vertical deflection can be read directly from the ruled graticule. Second, the input stage variable attenuator should be balanced for dc so the trace does not shift position vertically as attenuation is increased or decreased. And, third, the step attenuators should be compensated so that the attenuation is constant for any frequency within the passband of the instrument.

### Vertical Gain Adjust

You will need a signal of known amplitude to calibrate the gain of the vertical amplifier. The calibrator signal from any Tektronix oscilloscope or from other voltage calibrators is a possible source of such a signal. Or, since the amplifier is dc coupled, you can use an accurately known dc voltage or a dc voltage and an accurate voltmeter.

1. Depending on the method used set the VOLTS/DIV switch to the position that will result in a close-to-full-scale deflection when the calibrating signal is applied. Check to see that the VARIABLE control is turned full right to the CALIBRATED position and if a dc voltage will be used for calibration the AC-DC switch must be in the DC position.

2. Apply the calibrating signal and adjust the VERT GAIN ADJ control so the deflection read from the ruled graticule agrees with the known amplitude of the calibrating signal.

### DC Balance

The vertical amplifier VARIABLE gain control is located between the cathodes of the first stage and any difference in dc level between these two cathodes will cause the trace to shift vertically as the VARIABLE control is rotated. The DC BAL control permits the dc level of one of the cathodes to be adjusted to match the other.

1. Center the trace horizontally on the screen and rotate the VARIABLE control. Adjust the DC BAL control until the trace does not move as the VARIABLE control is rotated.



Fig. 4-12. Type 360, Front view.

## Vertical Attenuators

There are two types of adjustment to be made. One is to compensate the various attenuators so the ac attenuation is equal to the dc attenuation. This involves a moderately short time constant and can be recognized by a slight rounding or overshoot at the leading corner of a 1-kc square wave. The other type of adjustment is to set the input capacitance equal in all positions of the attenuator so the 10 to 1 probe can be compensated for the instrument. This latter adjustment can be recognized by a downward or upward slope of about the first half of the top or bottom of a 1-kc square wave.

1. Attach the probe to the 360 VERTICAL INPUT and set the VOLTS/DIV switch to .05.



Connect the probe to a source of square waves such as the calibrator signal from a Tektronix oscilloscope or a Tektronix Type 105 Square-Wave Generator. Display about four or five cycles of a 1-kc square wave and adjust the probe trimmer to make the top of the square wave as flat as possible.

2. Turn the VOLTS/DIV switch to .5 and adjust C1 for a flat top and C2 for a square corner on the square wave.

3. Turn the VOLTS/DIV switch to 5 and adjust C4 for a flat top and C5 for a square corner on the square wave.

4. As a check, switch to 50 VOLTS/DIV and examine the square wave. In this position the two attenuators are cascaded and any slight misadjustment may add and become more noticeable. If there is any evidence of misadjustment repeat steps 2 and 3 until the shape of the square wave is acceptable in all three positions of the attenuator switch (50, 5, and .5).

### Type 161

At the factory, a pulse width series of three capacitors is chosen arbitrarily from the six possible series shown on Fig. 4-19, page 4-13.

### Adjustment

#### Pos. Pulse Delay

The Type 161 Pulse Generator is adjusted at the factory so that the OUTPUT PULSE DELAY dial will read correctly with an input sawtooth wave beginning at +150 volts and decreasing to +20 volts. If a negative going sawtooth with other dimensions is used the dial calibrations can be accommodated to the new dimensions by means of screwdriver limit controls accessible from the front panel. Turn the OUTPUT PULSE DELAY control full counterclockwise to zero. Trigger both an oscilloscope sweep and the Type 161 with the sawtooth and display one sawtooth on the oscilloscope. The TEKTRONIX Type 532 oscilloscope can be used for this purpose. Turn the OUTPUT PULSE DELAY CCW to .1. Adjust the POS. DELAY limit pot so the leading (left) edge of the pulse is at the 1 CM graticule division on the test scope. Set the OUTPUT PULSE dial to 1.0 and adjust NEG. DELAY so the pulse just drops off the right end of the sawtooth on the test scope. It may be necessary to go over these adjustments again to get proper

calibration as there is some interaction between them.

To check linearity, set OUTPUT PULSE DELAY to .5. The leading edge of the pulse should appear between the 4 and 6 CM mark on the test scope graticule.

### Pulse Width Cal.

Observe the output pulse on an oscilloscope with a calibrated time base. Set the PULSE WIDTH switch to 0.1 MILLISECONDS and the PULSE WIDTH MULTIPLIER dial full clockwise to 1.0. Adjust PULSE WIDTH CAL. screwdriver adjustment, if necessary, until pulse width measures 0.1 millisecond on the calibrated oscilloscope.

### 0.01 Millisecond Pulse Width

Turn PULSE WIDTH switch full counterclockwise to 0.01 MILLISECONDS, and if necessary, adjust C6, a variable ceramic capacitor

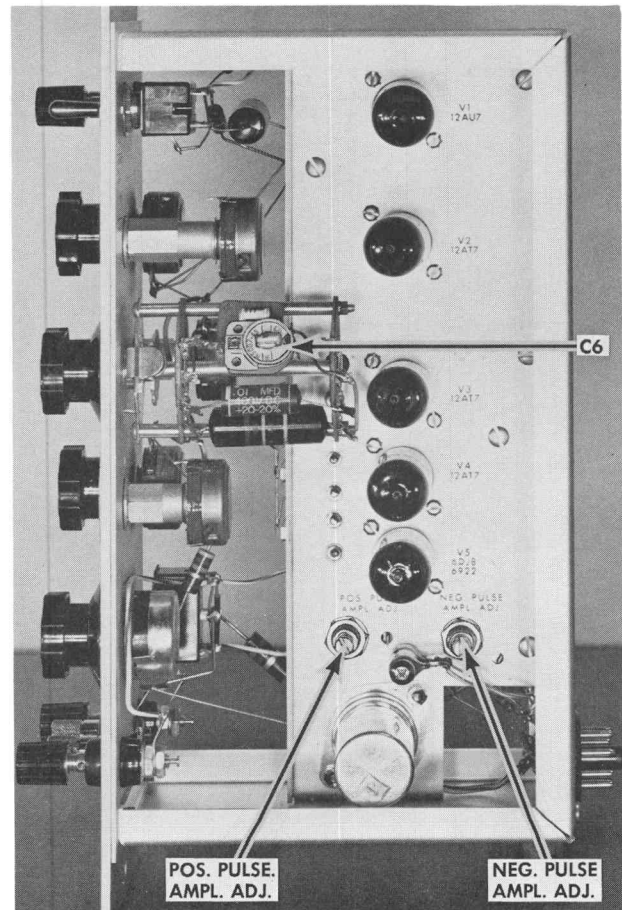

Fig. 4-13. Right side view of the Type 161 showing location of the adjustment points.

mounted on the PULSE WIDTH switch, SW2, until the pulse width measures 0.01 milliseconds on the calibrated oscilloscope.

### Pos. Pulse Ampl. Adj.

Observe the pulse output on a voltage-calibrated oscilloscope. Set the PULSE POLARITY switch to POS. and the PULSE AMPLITUDE dial full clockwise to 50. If necessary adjust the POS. PULSE AMPL. ADJ. screwdriver adjustable 2-megohm variable resistor, R30, until the pulse amplitude measures 50 volts on the calibrated oscilloscope.

### Neg. Pulse Ampl. Adj.

Observe the pulse output on a voltage-calibrated oscilloscope. Set the PULSE POLARITY switch to NEG. and the PULSE AMPLITUDE switch full clockwise to 50. If necessary adjust R29, labeled NEG. PULSE AMPL. ADJ., a

5-k screwdriver-adjustable variable resistor until the pulse amplitude measures 50 volts on the calibrated oscilloscope.

### Pulse Compensation Capacitors

Three screwdriver adjustable ceramic capacitors, C10, C11 and C12, are located inside the case on the left side of the subchassis. These capacitors compensate the voltage divider networks from grid-to-ground capacitance and should not need readjustment. Readjustment might occasionally be necessary after tube replacement, however. The uppermost of the three capacitors, C10, 3-12  $\mu\mu\text{f}$ , compensates the trailing edge of the pulse. The bottom capacitor, C11, 1.5-7  $\mu\mu\text{f}$ , compensates the leading edge of the negative pulse, which is observable with the PULSE POLARITY switch set to the NEG. position. The center capacitor, C12, 1.5-7  $\mu\mu\text{f}$ , compensates the leading edge of the positive pulse, observable with the PULSE POLARITY switch set to the POS. position. Observe the pulses on a wide-band oscilloscope capable of presenting the pulses accurately and adjust the compensating capacitors until the pulses are most nearly square.

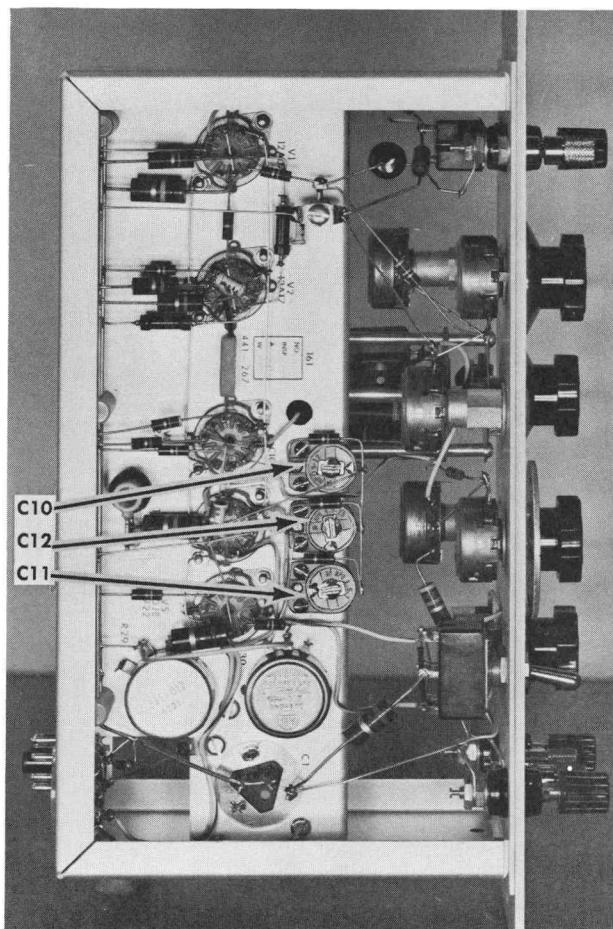

Fig. 4-14. Left side view, Type 161.

### Type 162

#### Adjustment

The Type 162 Waveform Generator has three screwdriver adjustments. One adjustment, R21B, is on the upper right of the front panel, marked CAL. This adjustment permits the pulse interval to be accommodated to the calibrations of the PULSE INTERVAL dial when the VERNIER dial is turned counterclockwise to the CALIBRATED POSITION index mark. Observe the interval between pulses, with the MULTIPLIER switch set to 1 times or 10 times, using an oscilloscope with a calibrated time base, such as the TEKTRONIX Type 532, and if necessary adjust the CAL control until the dial calibrations correspond to the pulse interval.

The second adjustment is C3B, the variable ceramic capacitor mounted on the MULTIPLIER switch in the 0.1-times position. Do not change this adjustment until you have determined that the CAL screwdriver adjustment is correct for the 1-times and 10-times positions of the MULTIPLIER switch. Be sure the VERNIER

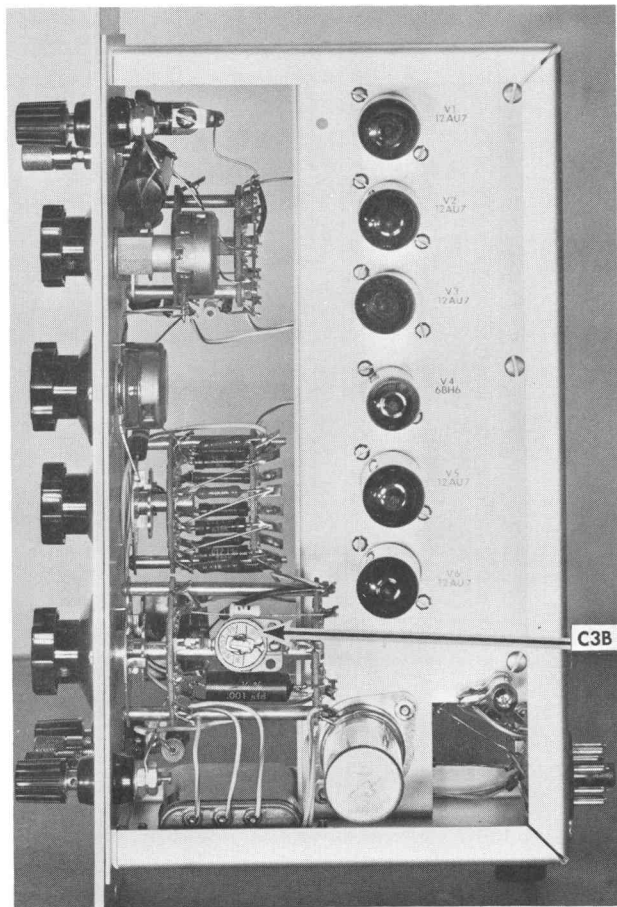

Fig. 4-15. Right side view of the Type 162 showing location of the adjustment points.

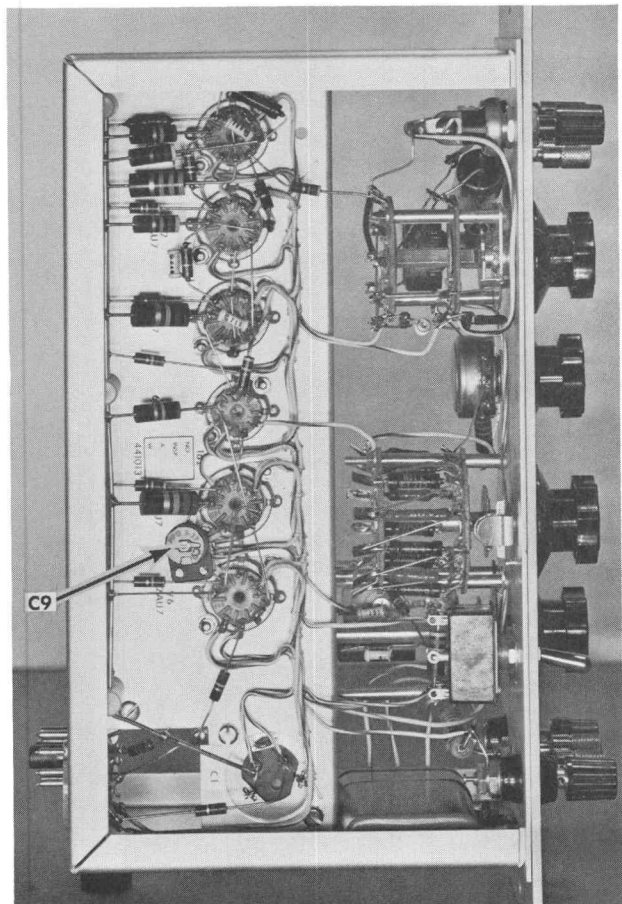

Fig. 4-16. Left side view, Type 162.

control is set to the CALIBRATED POSITION index mark. Then turn the MULTIPLIER switch to the 0.1-times position and if necessary adjust C3B until the pulse interval is 0.1 milliseconds as measured on the calibrated oscilloscope.

The third adjustment is C9, located on the left side of the chassis between the tube sockets of V5 and V6. Adjust C9 for optimum flat top on the pulse waveform by observation of the oscilloscope display.

### Pulse Width Capacitors

#### Type 163

If it should become necessary to replace one of the pulse-width determining capacitors C52, C53, or C54, we recommend that you order a complete set of three from the factory and replace the whole group. Be sure to state that the replacements are to be used in a Type

163 Pulse Generator and include the instrument serial number.

At the factory, a pulse-width series of three capacitors is chosen arbitrarily from the six possible series shown on Fig. 4-20, page 4-13.

### Pos. Pulse Delay

The Type 163 Pulse Generator is adjusted at the factory so that the OUTPUT PULSE DELAY dial will read correctly with an input sawtooth wave beginning at +150 volts and decreasing to +20 volts. If a negative going sawtooth with other dimensions is used the dial calibrations can be accommodated to the new dimensions by means of screwdriver limit controls accessible from the front panel. Turn the OUTPUT PULSE DELAY control full counterclockwise to zero. Trigger both an oscilloscope sweep and the Type 163 with the sawtooth and display at least two pulses on the oscilloscope. The TEKTRONIX Type 532 oscilloscope

can be used for this purpose. Adjust the POS. DELAY LIMIT screwdriver adjustment until the pulse is generated at the start of the sweep. Then turn the OUTPUT PULSE DELAY control full clockwise to 1.0 and adjust the NEG. DELAY LIMIT screwdriver adjustment until the pulse is generated at the completion of the sawtooth. Then repeat the adjustment procedure because the two controls are slightly interacting.

### Pulse Width Calibrator

Observe the output pulse on an oscilloscope with a calibrated time base. Set the PULSE WIDTH switch to 100 microseconds and the PULSE WIDTH MULTIPLIER dial clockwise to 1.0. Adjust R42, labeled, PULSE WIDTH CAL., a front-panel screwdriver adjustment, if necessary, until the pulse width measures 100  $\mu$ seconds on the calibrated oscilloscope.

### 1 Microsecond Pulse Width

Turn PULSE WIDTH switch full counter-

clockwise to 1 microsecond, and if necessary, adjust C50, a variable ceramic capacitor mounted on the PULSE WIDTH switch, SW20, until the pulse width measures 1 microsecond on the calibrated oscilloscope.

### Pulse Amplitude Calibrator

Observe the pulse output on a voltage-calibrated oscilloscope. Set the PULSE AMPLITUDE dial full clockwise to 25. If necessary adjust the PULSE AMPLITUDE CALIBRATOR screwdriver adjustable variable resistor until the pulse amplitude measures 25 volts on the calibrated oscilloscope.

### Pulse Compensation Capacitors

A screwdriver adjustable ceramic capacitor, C63, is located inside the case on the left side of the subchassis. This capacitor compensates the voltage divider network for grid-

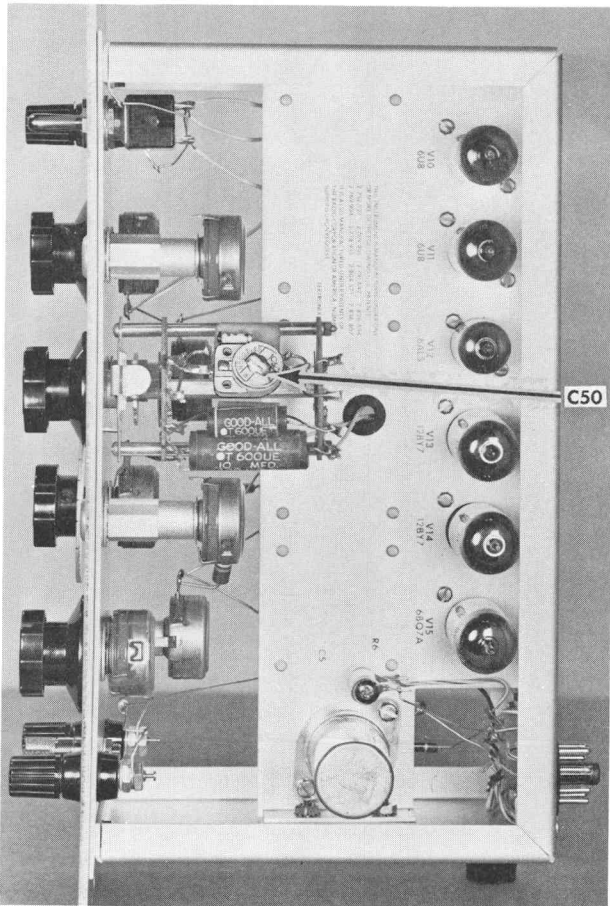

Fig. 4-17. Right side view of the Type 163 showing location of the adjustment points.

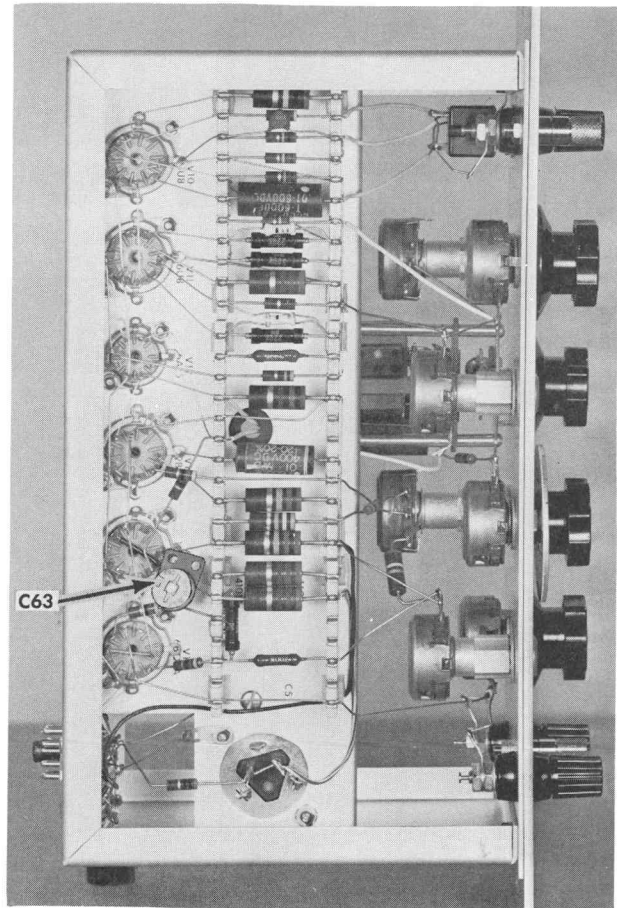

Fig. 4-18. Left side view, Type 163.

to-ground capacitance and should not need readjustment. Readjustment might occasionally be necessary after tube replacement, however. C63 compensates the leading edge of the pulse. Observe the pulses on an oscilloscope capable

of presenting the pulses accurately, such as TEKTRONIX Type 532, and adjust the compensating capacitor until the pulses are most nearly square.

	Series 4-L	Series 4-M	Series 4-N	Series 4-P	Series 4-Q	Series 4-R
C7, $\mu\mu f$	970	980	990	1000	1010	1020
C8, $\mu f$	.0097	.0098	.0099	.01	.0101	.0102
C9, $\mu f$	.097	.098	.099	.1	.101	.102

Fig. 4-19. Type 161 Pulse Width Capacitor Selections.

The values shown are minimum with tolerances -0% to +1%.

	Series 4-L	Series 4-M	Series 4-N	Series 4-P	Series 4-Q	Series 4-R
C52, $\mu\mu f$	950	960	970	980	990	1000
C53, $\mu f$	.0097	.0098	.0099	.01	.0101	.0102
C54, $\mu f$	.097	.098	.099	.1	.101	.102

Fig. 4-20. Type 163 Pulse Width Capacitor Selections.

The values shown are minimum with tolerances -0% to +1%.



U U





## PARTS LIST ABBREVIATIONS

BHB	binding head brass	int	internal
BHS	binding head steel	lg	length or long
cap.	capacitor	met.	metal
cer	ceramic	mtg hdw	mounting hardware
comp	composition	OD	outside diameter
conn	connector	OHB	oval head brass
CRT	cathode-ray tube	OHS	oval head steel
csk	countersunk	PHB	pan head brass
DE	double end	PHS	pan head steel
dia	diameter	plstc	plastic
div	division	PMC	paper, metal cased
elect.	electrolytic	poly	polystyrene
EMC	electrolytic, metal cased	prec	precision
EMT	electrolytic, metal tubular	PT	paper, tubular
ext	external	PTM	paper or plastic, tubular, molded
F & I	focus and intensity	RHB	round head brass
FHB	flat head brass	RHS	round head steel
FHS	flat head steel	SE	single end
Fil HB	fillister head brass	SN or S/N	serial number
Fil HS	fillister head steel	SW	switch
h	height or high	TC	temperature compensated
hex.	hexagonal	THB	truss head brass
HHB	hex head brass	thk	thick
HHS	hex head steel	THS	truss head steel
HSB	hex socket brass	tub.	tubular
HSS	hex socket steel	var	variable
ID	inside diameter	w	wide or width
incd	incandescent	WW	wire-wound



## PARTS ORDERING INFORMATION

Replacement parts are available from or through your local Tektronix, Inc. Field Office or representative.

Changes to Tektronix instruments are sometimes made to accommodate improved components as they become available, and to give you the benefit of the latest circuit improvements developed in our engineering department. It is therefore important, when ordering parts, to include the following information in your order: Part number, instrument type or number, serial or model number, and modification number if applicable.

If a part you have ordered has been replaced with a new or improved part, your local Tektronix, Inc. Field Office or representative will contact you concerning any change in part number.

## SPECIAL NOTES AND SYMBOLS

- ×000 Part first added at this serial number
- 00× Part removed after this serial number
- \*000-0000-00 Asterisk preceding Tektronix Part Number indicates manufactured by or for Tektronix, Inc., or reworked or checked components.
- Use 000-0000-00 Part number indicated is direct replacement.
-  Screwdriver adjustment.
-  Control, adjustment or connector.

# SECTION 5

## ELECTRICAL PARTS LIST

### Type 126

#### Bulbs

					Tektronix Part Number
B101	#47				150-001

#### Capacitors

Values fixed unless marked Variable.  
Tolerances  $\pm 20\%$  unless otherwise indicated.

C105	.0047 $\mu\text{f}$	PT	400 v		285-506
C114	.01 $\mu\text{f}$	PT	400 v		285-510
C118A,B	2 x 15 $\mu\text{f}$	EMC	350 v	-10% +100%	290-056
C120	2 x 20 $\mu\text{f}$	EMC	450 v	-10% +50%	290-037
C132	.01 $\mu\text{f}$	PT	400 v		285-510

#### Fuses

Fuse	1 amp	3 AG	Fast-Blo for 117 v, 60 cycle operation		159-022
Fuse	0.5 amp	3 AG	Fast-Blo for 234 v, 60 cycle operation		159-025
Fuse	1 amp	3 AG	Slo-Blo for 117 v, 50 cycle operation		159-019
Fuse	0.5 amp	3 AG	Slo-Blo for 234 v, 50 cycle operation		159-032

#### Resistors

Resistors are fixed, composition,  $\pm 10\%$  unless otherwise indicated.

R105	47 k	$\frac{1}{2}$ w			302-473
R107	47 k	$\frac{1}{2}$ w			302-473
R108	150 k	$\frac{1}{2}$ w			302-154
R110	2.2 meg	$\frac{1}{2}$ w			302-225
R112	1 k	$\frac{1}{2}$ w			302-102
R114	470 k	$\frac{1}{2}$ w			302-474
R116	38 k	$\frac{1}{2}$ w		Prec. 1%	309-124
R117	10 k	2 w	Var.	WW -170 Adjust	311-015
R118	38 k	$\frac{1}{2}$ w		Prec. 1%	309-124
R122	560 k	$\frac{1}{2}$ w			302-564
R123	47 k	$\frac{1}{2}$ w			302-473
R124	390 k	$\frac{1}{2}$ w			302-394
R130	1 meg	$\frac{1}{2}$ w			302-105
R132	1 k	$\frac{1}{2}$ w			302-102
R133	500 k	$\frac{1}{2}$ w		Prec. 1%	309-003
R134	370 k	$\frac{1}{2}$ w		Prec. 1%	309-055
R140	111 k	$\frac{1}{2}$ w		Prec. 1%	309-046
R141	220 k	$\frac{1}{2}$ w		Prec. 1%	309-052
R143	150 k	$\frac{1}{2}$ w			302-154

**Electrical Parts List—Type 160 Series**

**Switches**

			Tektronix Part Number
SW101	Toggle	POWER ON	260-134

**Transformers**

T101	Power Transformer		*120-076
------	-------------------	--	----------

**Electron Tubes**

V105	5651		154-052
V110	6AU6		154-022
V115	12B4		154-044
V118	6BW4		154-119
V120	6BW4		154-119
V125	12B4		154-044
V130	6AN6		154-078

**Type 160 & 160A**

**Bulbs**

B1	X620-up	#47	150-001
----	---------	-----	---------

**Capacitors**

Values fixed unless marked variable  
Tolerance  $\pm 20\%$  unless otherwise indicated.

C1 & 2	101-323	2 x 20 $\mu f$	EMC	450 v	-10+50%	290-037
	324-619	2 x 40 $\mu f$	EMC	450 v	-10+50%	290-043
	620-up	2 x 20 $\mu f$	EMC	450 v	-10+100%	Use 290-010
C3	101-619X	.005 $\mu f$	Discap	500 v	GMV	283-001
C4	101-619X	.005 $\mu f$	Discap	500 v	GMV	283-001
C5 & 6	101-619X	2 x 20 $\mu f$	EMC	450 v	-10+50%	290-036
C7		.005 $\mu f$	Discap	500 v	GMV	283-001
C8	101-619X	.005 $\mu f$	Discap	500 v	GMV	283-001
C9	X620-up	.047 $\mu f$	PT	400 v		285-519
C11	X620-11429	.1 $\mu f$	PT	400 v		285-526
C11	11430-up	.5 $\mu f$	MPT	400 v		285-0537-00
C30	X620-up	125 $\mu f$	EMC	450 v	-10+50%	Use 290-0017-00
C41	X620-up	.047 $\mu f$	PT	400 v		285-519
C47	X620-up	.005 $\mu f$	Discap	500 v	GMV	283-001

**Fuses**

101-619	3 amp	3 AG	Slo-Blo for 117 V, 60 cycle operation	159-005
620-up	4 amp	3 AG	Slo-Blo for 117 V, 50-60 operation	Use 159-027
101-619	1.6 amp	3 AG	Slo-Blo for 234 V, 50 cycle operation	159-003
620-up	2 amp	3 AG	Slo-Blo for 234 V, 50-60 operation	Use 159-023

Resistors

Tektronix  
Part Number

Resistors are fixed, composition,  $\pm 10\%$  unless otherwise indicated.

R1	101-619	220 k	1 w					304-224
	620-up	47 k	1/2 w					302-473
R2	101-619	1 meg	1/2 w					302-105
	620-up	150 k	1/2 w					302-154
R3	101-619	47 k	1 w					304-473
	620-up	2.2 meg	1/2 w					302-225
R4	101-619X	10 k	1/2 w					302-103
R5	101-619X	470 k	1/2 w					302-474
R5A	101-619X	50 k	2 w	Var.		ADJ TO +225 V		311-023
R5B	101-619X	433 k	1/2 w		Prec.	1%		309-001
R5C	101-619X	333 k	1/2 w		Prec.	1%		309-053
R7	X620-up	47 k	1/2 w					302-473
R8	101-619	270 k	1/2 w					302-274
	620-up	470 k	1/2 w					302-474
R9	101-619	500 k	1/2 w		Prec.	1%		309-003
	620-up	38 k	1/2 w		Prec.	1%		309-124
R10	101-619	500 k	1/2 w		Prec.	1%		309-003
	620-up	10 k	2 w	Var.	WW	ADJ TO -170V		311-015
R11	101-619	220 k	1 w					304-224
	620-up	38 k	1/2 w		Prec.	1%		309-124
R12	101-619X	1 meg	1/2 w					302-105
R13	101-619	1 k	1/2 w					302-102
	620-6819X	10 k	1/2 w					302-103
R14	101-619	33 k	1/2 w					302-333
	620-up	100 k	1/2 w					302-104
R15	101-6819	470 k	1/2 w					302-474
	6820-up	1.5 meg	1/2 w					302-155
R15A	101-619X	10 k	2 w	Var.	WW	ADJ TO -170V		311-015
R15B	101-323	82 k	1/2 w				Use	309-043
	324-619X	82 k	1/2 w		Prec.	1%		309-043
R15C	101-323	82 k	1/2 w				Use	309-043
	324-619X	82 k	1/2 w		Prec.	1%		309-043
R16	X324-619	100 k	1/2 w					302-104
	620-up	1 k	1/2 w					302-102
R17	X620-up	1 k	1/2 w					302-102
R20	X620-up	100 k	1/2 w					302-104
R30	X620-up	330 k	1/2 w					302-334
R31	X620-up	220 k	1/2 w					302-224
R32	X620-739	390 k	1/2 w				Use	302-564
	740-up	560 k	1/2 w					302-564
R33	X620-up	1.5 meg	1/2 w				Use	302-155
R34	X620-up	1 k	1/2 w					302-102
R35	X620-up	1 k	1/2 w					302-102
R40	X620-up	470 k	1/2 w					302-474
R41	X620-up	490 k	1/2 w		Prec.	1%		309-002
R42	X620-up	50 k	2 w	Var.		ADJ TO +225V		311-023
R43	X620-up	333 k	1/2 w		Prec.	1%		309-053
R46	X620-up	270 k	1/2 w					302-274
R47	X620-up	390 k	1/2 w		Prec.	1%		309-056
R48	X620-2277	433 k	1/2 w		Prec.	1%	Use	309-170
	2278-up	429 k	1/2 w			1%		309-170

# Electrical Parts List—Type 160 Series

## Switches

		Tektronix Part Number
SW1	Toggle	260-134

## Transformers

T1	101-619	Power Transformer T160PA Primary: 117-234 volts 60 cycle Secondary: Term. 5, 6, 7, 210-0-210 v at 175 ma Term. 8, 9, 10, 260-0-260 v at 175 ma Term. 11, 12, 5.2 v at 2A Term. 13, 14, 5.2 v at 2A Term. 15, 16, 6.5 v at 15A	*120-009
	620-up	Power Transformer T160PB1 Primary: 117/234 volts 50-60 cycle Secondary: Term. 7, 8, 9, 260-0-260 at 250 ma Term. 14, 15, 16,, 227-0-227 at 150 ma Term. 5, 6, 6.3 vac at 12.5A Term. 10, 11, 6.3 vac at 12.5A Term. 12, 13, 5 vac at 4A Term. 20, 21, 5 vac at 2A	*120-054

## Electron Tubes

V1		GZ34/5AR4	Use 154-0168-00
V2	101-619X	5V4G	154-008
V3	101-619X	6AS7G	154-020
V4	101-619X	6AU6	154-022
V5	101-619X	5651	154-052
V6	101-619	6AU6	154-022
	620-up	5651	154-052
V7	101-619	12AU7	154-041
	620-up	6U8	154-033
V8	X324-619X	5V4G	154-008
V16	X620-up	12B4	154-044
V17	X620-up	12B4	154-044
V30	X620-up	GZ34/5AR4	Use 154-0168-00
V31	X620-up	GZ34/5AR4	Use 154-0168-00
V33	X620-up	6AU6	154-022
V35	X620-up	6080 (Alternate-6AS7G)	154-056
V47	X620-up	6AW8	154-095

## Type 161

### Capacitors

Tolerance  $\pm 20\%$  unless otherwise indicated.  
Values fixed unless marked Variable.

C1A,B	2 x 15 $\mu$ f	EMC	350 v	-10+50%	Use 290-006
C2	.1 $\mu$ f	PTM	400 v		285-526
C3	12 $\mu$ $\mu$ f	Cer.	500 v	10%	281-506
C4	22 $\mu$ $\mu$ f	Cer.	500 v		281-510
C5	10 <sup>0</sup> $\mu$ $\mu$ f	Mica	500 v	10%	283-505

Capacitors (continued)

							Tektronix Part Number
C6A		82 $\mu\mu\text{f}$	Cer.		500 v	10%	281-528
C6B		7-45 $\mu\mu\text{f}$	Cer.	Var.	500 v		281-012
C7		900 pf			}	Timing Series	Use *295-074
C8		.01 $\mu\text{f}$					
C9		.1 $\mu\text{f}$					
C10		3-12 $\mu\mu\text{f}$	Cer.	Var.			
C11		1.5-7 $\mu\mu\text{f}$	Cer.	Var.	500 v	281-005	
C12	101-135	1.5-7 $\mu\mu\text{f}$	Cer.	Var.	500 v	Use 281-010	
	136-up	4.5-25 $\mu\mu\text{f}$	Cer.	Var.	500 v	281-010	
C21	X1396-up	2.2 $\mu\mu\text{f}$	Cer.		500 v	$\pm 0.5 \mu\mu\text{f}$	281-500

Inductors

L36	X1396-up	1.2 mh					*108-122
-----	----------	--------	--	--	--	--	----------

Resistors

Resistors are fixed, composition,  $\pm 10\%$  unless otherwise indicated.

R1		180 k	1 w				304-184
R2		100 k	$\frac{1}{2}$ w				302-104
R3		100 k	2 w				306-104
R4		100 $\Omega$	$\frac{1}{2}$ w				302-101
R5		10 k	5 w		WW	5%	308-008
R6		27 k	1 w				304-273
R7		100 k	$\frac{1}{2}$ w				302-104
R8		470 k	$\frac{1}{2}$ w				302-474
R9A		100 k	2 w	Var.	output pulse delay	(Pos. Trigger Bias)	311-026
R9B		100 k	2 w	Var.		Pos. Delay Limit	311-026
R9C		50 k	2 w	Var.		Neg. Delay Limit	311-023
R10	101-135	1 meg	$\frac{1}{2}$ w				Mod w/R11
	136-2044	1.1 meg	$\frac{1}{2}$ w			5%	Mod w/R11
	2045-up	1 meg	$\frac{1}{2}$ w			1%	309-014
R11	101-2044	1 meg	$\frac{1}{2}$ w			2%	Mod w/R10
	2045-up	1 meg	$\frac{1}{2}$ w			1%	309-014
R12		22 k	1 w				304-223
R13		2.7 k	$\frac{1}{2}$ w				302-272
R14		22 k	1 w				304-223
R15		470 k	$\frac{1}{2}$ w				302-474
R16		470 k	$\frac{1}{2}$ w				Use 302-474
R17		47 k	$\frac{1}{2}$ w				302-473
R18		22 k	$\frac{1}{2}$ w				302-223
R19		820 k	$\frac{1}{2}$ w				302-824
R20	101-2167	120 k	$\frac{1}{2}$ w				Mod w/R34
	2168-3819	150 k	$\frac{1}{2}$ w				Mod w/R34
	3820-up	150 k	$\frac{1}{2}$ w			5%	301-154
R21		1.0 meg	$\frac{1}{2}$ w				302-105
R22		820 k	$\frac{1}{2}$ w				302-824
R23	101-1395	22 k	2 w				306-223
	1396-7929	12 k	2 w				306-123
	7930-9198	27 k	1 w			5%	303-273
	9199-up	15 k	2 w				306-153
R24		2 meg	Selected for linearity				Pulse Width Multiplier Use *312-104

# Electrical Parts List—Type 160 Series

## Resistors (continued)

						Tektronix Part Number
R25		Selected to match R24. (See Text)				
R26		50 k	2 w	Var.		Pulse Width Cal. 311-023
R27		47 k	1 w			304-473
R28		1 meg	1/2 w			302-105
R29		5 k	2 w	Var.	WW	Neg. Pulse Ampl. Adj. 311-012
R30		2 meg	2 w	Var.		Pos. Pulse Ampl. Adj. 311-042B
R31	101-2542	5 k	2 w	Var.	WW	Use 311-128
	2543-2712	10 k	2 w		WW	Use 311-128
	2713-up	15 k	1/2 w		WW	Pulse Amplitude 311-128
		6 k	2 w	Var.	WW	
R32	101-1395	1.2 meg	1/2 w			302-125
	1396-up	1 meg	1/2 w			302-105
R33		5.6 k	2 w			306-562
R34	101-3819	120 k	1/2 w			Mod w/R20
	3820-up	120 k	1/2 w			5% 301-124
R35		2.7 k	2 w			306-272
R36	X1396-up	10 k	1/2 w			302-103
R37	X7930-9198	30 k	1 w			5% 303-303
R37	9199-up	150 k	1/2 w	(Selected)		302-154

## Switches

		Wired	Unwired
SW1	toggle		260-014
SW2	rotary	Use *262-620	*260-030
SW3	toggle		260-014
			TRIGGER SELECTOR
			PULSE WIDTH
			PULSE POLARITY

## Electron Tubes

V1		12AU7	154-041
V2		12AT7	154-039
V3		12AT7	154-039
V4		12AT7	154-039
V5	101-3193	6J6	154-032
	3194-up	6DJ8	154-187

## Type 162

### Capacitors

Values fixed unless marked Variable.  
Tolerance  $\pm 20\%$  unless otherwise indicated.

C1A,B	2 x 15 $\mu f$	EMC	350 v	10+100%	Use 290-006
C2	.1 $\mu f$	PT	600 v		285-528
C3A	12 $\mu \mu f$	Cer.	500 v	10%	281-506
C3B	82 $\mu \mu f$	Cer.	500 v	10%	281-528
C3C	7-45 $\mu \mu f$	Cer.	500 v		281-012



Capacitors (continued)

						Tektronix Part Number	
C3D	101-562	.001 $\mu$ f	} Selected Timing Series			Use *050-059	
C3E	101-562	.01 $\mu$ f					
C3F	101-562	.1 $\mu$ f					
C3G	101-562	1 $\mu$ f					
C3D	563-up	.001 $\mu$ f	} Mylar Timing Series	Mylar			*291-008
C3E	563-up	.01 $\mu$ f					
C3F	563-up	.1 $\mu$ f					
C3G	563-up	1.0 $\mu$ f					
C4		22 $\mu$ f			500 v		281-510
C5		.005 $\mu$ f	Discap		500 v	GMV	283-001
C6		470 $\mu$ f	Cer.		500 v		281-525
C7		25 $\mu$ f	Cer.		500 v	5%	281-552
C8		22 $\mu$ f	Cer.		500 v		281-510
C9	101-1506	4.7 $\mu$ f	Cer.		500 v	Selected	*295-001
	1507-up	3-12 $\mu$ f	Cer.	Var.	500 v		281-009
C10	101-119	12 $\mu$ f	Cer.		500 v	10%	281-506
	120-up	22 $\mu$ f	Cer.		500 v		281-510
C12	X7015-up	.005 $\mu$ f	Discap		500 v		283-001

Resistors

Resistors are fixed, composition,  $\pm 10\%$  unless otherwise indicated.

R1		220 $\Omega$	$\frac{1}{2}$ w				302-221
R2		8 k	5 w		WW	5%	308-007
R3		47 k	$\frac{1}{2}$ w				302-473
R4		1 meg	$\frac{1}{2}$ w				302-105
R5	101-119	22 k	1 w				Mod w/R16
	120-159	10 k	1 w				Mod w/R16
	160-up	8.2 k	1 w			5%	Use 303-822
R6	101-119	680 k	$\frac{1}{2}$ w				302-684
	120-up	750 k	$\frac{1}{2}$ w		Prec.	1%	309-010
R7	101-119	1.2 k	1 w				304-122
	120-up	33 k	2 w				306-333
R8	101-119	1 meg	$\frac{1}{2}$ w				302-105
	120-up	700 k	$\frac{1}{2}$ w		Prec.	1%	309-008
R9	101-119	22 k	1 w				304-223
	120-up	15 k	1 w				304-153
R10		470 k	$\frac{1}{2}$ w				302-474
R11	101-159	560 k	$\frac{1}{2}$ w				Use 302-474
	160-up	470 k	$\frac{1}{2}$ w				302-474
R12		2.2 meg	$\frac{1}{2}$ w				302-225
R13		47 k	1 w				304-473
R14	101-3294	470 k	$\frac{1}{2}$ w				Use 301-474
	3295-up	470 k	$\frac{1}{2}$ w			5%	301-474
R15	101-3294	680 k	$\frac{1}{2}$ w				Use 301-684
	3295-up	680 k	$\frac{1}{2}$ w			5%	301-684
R16	101-159	18 k	2 w				Mod w/R5
	160-13269	22 k	2 w				306-223
R16	13270-up	20 k	2 w			5%	305-0203-00
R17		1 meg	$\frac{1}{2}$ w				302-105
R18		1.5 meg	$\frac{1}{2}$ w				302-155
R19		100 k	1 w				304-104
R20A		1.5 meg	$\frac{1}{2}$ w		Prec.	1%	309-017
R20B		.39 meg	$\frac{1}{2}$ w		Prec.	1%	309-056
R20C		.49 meg	$\frac{1}{2}$ w		Prec.	1%	309-002

Electrical Parts List—Type 160 Series

Resistors (continued)

						Tektronix Part Number	
R20D		.61 meg	1/2 w		Prec.	1%	309-006
R20E		.78 meg	1/2 w		Prec.	1%	309-011
R20F		.97 meg	1/2 w		Prec.	1%	309-012
R20G		1.23 meg	1/2 w		Prec.	1%	309-016
R20H		1.55 meg	1/2 w		Prec.	1%	309-018
R20I		1.94 meg	1/2 w		Prec.	1%	309-022
R20J		2.44 meg	1/2 w		Prec.	1%	309-024
R20K		3.10 meg	1/2 w		Prec.	1%	309-027
R21A	101-212	50 k	2 w	Var.		Vernier	311-023
	213-up	20 k	2 w	Var.		Vernier	311-018
R21B	101-212	50 k	2 w	Var.		Cal.	311-023
	213-up	20 k	2 w	Var.		Cal.	311-018
R21C	101-212	150 k	1 w				304-154
	213-up	56 k	1 w				304-563
R22		27 k	2 w				306-273
R23		150 k	1/2 w				302-154
R24		220 Ω	1/2 w				302-221
R25		47 k	1 w				304-473
R26		470 k	1/2 w				302-474
R27		470 k	1/2 w				302-474
R28	101-159	27 k	1 w			Use	306-273
	160-up	27 k	2 w				306-273
R29		470 k	1/2 w				302-474
R30		27 k	2 w				306-273
R31		680 k	1/2 w				302-684
R32		220 k	1/2 w				302-224

Switches

			Wired	Unwired
SW1	Rotary	OPERATING MODE	*262-013	*260-044
SW2	Pushbutton	MANUAL		*260-017
SW3	Rotary	MULTIPLIER	*262-012	*260-038
SW4	Toggle	GATE OUT, PULSE OUT		260-014
SW5	Rotary	WAVEFORM DURATION	*262-014	*260-024

Electron Tubes

V1	12AU7	154-041
V2	12AU7	154-041
V3	12AU7	154-041
V4	6BH6	154-026
V5	12AU7	154-041
V6	12AU7	154-041

**Type 163**

**Capacitors**

Values fixed unless marked Variable.  
Tolerance  $\pm 20\%$  unless otherwise indicated.

Tektronix  
Part Number

C5		2 x 15 $\mu f$	EMC	350 v	-10+100% GMV	Use 290-0006-00
C11		.001 $\mu f$	Cer.	500 v		
C15		.01 $\mu f$	PT	600 v		285-511
C23	101-182	22 $\mu\mu f$	Cer.	500 v		281-510
	183-up	12 $\mu\mu f$	Cer.	500 v	10%	281-506
C33	101-182	22 $\mu\mu f$	Cer.	500 v		281-510
	183-up	39 $\mu\mu f$	Cer.	500 v	10%	281-516
C42		.01 $\mu f$	PT	400 v		285-510
C50		7-45 $\mu\mu f$	Cer.	500 v		281-012
C51		56 $\mu\mu f$	Cer.	500 v	10%	281-521
C52		900 pf		}	Timing Series	Use *295-075
C53		.01 $\mu f$				
C54		.1 $\mu f$				
C63	101-1372	1.5-7 $\mu\mu f$	Cer.			
	1373-up	3-12 $\mu\mu f$	Cer.	500 v		281-009

**Resistors**

Resistors are fixed, composition,  $\pm 10\%$  unless otherwise indicated.

R5		10 $\Omega$	$\frac{1}{2}$ w			302-100
R6		8 k	5 w		WW	308-007
R10		180 k	$\frac{1}{2}$ w		5%	302-184
R11		100 k	$\frac{1}{2}$ w			302-104
R13		47 $\Omega$	$\frac{1}{2}$ w			302-470
R14		22 k	$\frac{1}{2}$ w			302-223
R15		470 k	$\frac{1}{2}$ w			302-474
R16		100 k	2 w			306-104
R20		100 k	2 w		Pos. Delay Limit	311-026
R21		100 k	2 w		Output Pulse Delay, Pos. Trigger Bias	311-026
R22		50 k	2 w	Var.	Neg. Delay Limit	311-023
R23	101-182	220 k	$\frac{1}{2}$ w			302-224
	183-up	220 k	$\frac{1}{2}$ w		Prec.	309-052
R24	101-182	470 k	$\frac{1}{2}$ w			302-474
	183-up	500 k	$\frac{1}{2}$ w		Prec.	309-003
R30		2.2 k	$\frac{1}{2}$ w		1%	302-222
R31	101-182	10 k	2 w			306-103
	183-up	8.2 k	2 w			306-822
R32		3.3 k	$\frac{1}{2}$ w			302-332
R33	101-182	220 k	$\frac{1}{2}$ w			302-224
	183-up	220 k	$\frac{1}{2}$ w		Prec.	309-052
R34	101-182	390 k	$\frac{1}{2}$ w			302-394
	183-up	433 k	$\frac{1}{2}$ w		Prec.	309-001
R40		2.5 k	5 w		WW	Use 308-127
R41		47 $\Omega$	$\frac{1}{2}$ w		5%	302-470

Electrical Parts List—Type 160 Series

Resistors (Cont'd)

					Tektronix Part Number	
R42		100 k	2 w	Var.	Pulse Width Calibrator	311-026
R43		470 k	1/2 w			302-474
R45		18 k	2 w			306-183
R46		39 k	1 w			304-393
R47		18 k	2 w			306-183
R48	101-182	4.7 k	2 w			306-472
	183-up	8.2 k	2 w		(2)	306-822
R49		47 Ω	1/2 w			302-470
R50	101-3289	Selected (nominal value 2.7 k)			10%	302-272
R50	3290-up	Selected (nominal value 4.7 k)			10%	302-472
R51		100 k	Selected for linearity		Var.	Pulse Width Mult. use *312-105
R52	X3290-up	1 m	1/2 w		10%	302-105
R60		150 k	1 w			304-154
R61	101-182	10 k	2 w	Var.	Pulse Amplitude Calibrator	311-016
	183-up	20 k	2 w	Var.	Pulse Amplitude Calibrator	311-018
R62		700 k	1/2 w		Prec.	1% 309-008
R63	101-182	750 k	1/2 w		Prec.	1% 309-010
	183-up	780 k	1/2 w		Prec.	1% 309-011
R64		47 Ω	1/2 w			302-470
R65		47 Ω	1/2 w			302-470
R66		2 k	2 w	Var.	Pulse Amplitude	311-008

Switches

				Wired	Unwired
SW10	Toggle	TRIGGER SELECTOR			260-014
SW20	Rotary	PULSE WIDTH		Use *262-621	*260-030

Electron Tubes

V10	6U8				154-033
V11	6U8				154-033
V12	6AL5				154-016
V13	12BY7				154-047
V14	12BY7				154-047
V15	6DJ8			Use	154-187

Type 360

Bulbs

B145	#47	Graticule Light			150-001
B146	#47	Graticule Light			150-001

Capacitors

Values fixed unless marked Variable.  
Tolerance ±20% unless otherwise indicated.

C1	4.5-25 μμf	Cer.	Var.	500 v	281-010
C2	4.5-25 μμf	Cer.	Var.	500 v	281-010
C3	100 μμf	Cer.		350 v	281-523
C4	4.5-25 μμf	Cer.	Var.	500 v	281-010
C5	4.5-25 μμf	Cer.	Var.	500 v	281-010

Capacitors (continued)

							Tektronix Part Number
C6		.001 $\mu$ f	Mica	500 v	5%		283-527
C7		47 $\mu$ $\mu$ f	Cer.	500 v			281-518
C10		.1 $\mu$ f	PTM	400 v			285-526
C30		4.7 $\mu$ $\mu$ f	Cer.	500 v	$\pm 1 \mu$ $\mu$ f		281-501
C31		.001 $\mu$ f	Cer.	500 v	GMV		283-000
C39		.01 $\mu$ f	Discap	500 v			283-002
C40		.005 $\mu$ f	Discap	500 v			283-001
C73	X132-up	2.2 $\mu$ $\mu$ f	Cer.	500 v	$\pm 3 \mu$ $\mu$ f		281-500
C76	101-131X	82 $\mu$ $\mu$ f	Cer.	500 v	10%		281-528
C90		.047 $\mu$ f	PTM	400 v			285-519
C92		.01 $\mu$ f	Cer.	500 v	GMV		283-002
C104		.001 $\mu$ f	Discap	500 v	GMV		283-000
C106		.001 $\mu$ f	Discap	500 v	GMV		283-000
C107		.001 $\mu$ f	PTM	1000 v			285-502
C114	X132-up	.02 $\mu$ f	Discap	150 v	GMV		283-004
C116	101-1929	.0068 $\mu$ f	PTM	3000 v			285-508
C116	1930-up	.01 $\mu$ f	Discap	2000 v			283-011
C117	101-1929	.0068 $\mu$ f	PTM	3000 v			285-508
C117	1930-up	.01 $\mu$ f	Discap	2000 v			283-011
C120	X1930-up	.001 $\mu$ f	Discap	500 v	GMV		283-000
C131		.047 $\mu$ f	PTM	400 v			285-519
C132		.022 $\mu$ f	PTM	400 v			285-515
C133	101-1929	.0068 $\mu$ f	PTM	3000 v			285-508
C133	1930-up	.01 $\mu$ f	Discap	2000 v			283-011
C134	101-1929	.0068 $\mu$ f	PTM	3000 v			285-508
C134	1930-up	.01 $\mu$ f	Discap	2000 v			283-011
C136	101-1929	.0068 $\mu$ f	PTM	3000 v			285-508
C136	1930-up	.01 $\mu$ f	Discap	2000 v			283-011
C140A,B		2 x 20 $\mu$ f	EMC	450 v	-10+50%	Use 290-0010-00	

Resistors

Resistors are fixed, composition,  $\pm 10\%$  unless otherwise indicated.

R2		900 k	$\frac{1}{2}$ w		Prec.	1%		309-111
R3		111 k	$\frac{1}{2}$ w		Prec.	1%		309-046
R5		990 k	$\frac{1}{2}$ w		Prec.	1%		309-013
R6		10.1 k	$\frac{1}{2}$ w		Prec.	1%		309-034
R30		1 meg	$\frac{1}{2}$ w		Prec.	1%		309-014
R31		100 k	$\frac{1}{2}$ w					302-104
R32		5.6 k	1 w			5%		303-562
R33		82 k	1 w			5%	Use	303-823
R34		7 k	2 w	Var.	10%	Volts/Div Variable	Use	311-223
R35		82 k	1 w			5%	Use	303-823
R37	X1690-up	150 k	$\frac{1}{2}$ w					302-154
R38		500 k	.2 w	Var.		DC Bal		311-068
R39		220 k	$\frac{1}{2}$ w					302-224
R40		2.2 k	$\frac{1}{2}$ w					302-222
R41		5.6 k	1 w			5%		303-562
R45		270 k	$\frac{1}{2}$ w					302-274
R46		2 x 100 k	(Concentric w/R71)			Horiz. Pos.		311-064
R47		270 k	$\frac{1}{2}$ w					302-274
R50		10 k	5 w		WW	5%		308-008
R51		1 k	$\frac{1}{2}$ w					302-102
R54		12 k	2 w					306-123
R55		12 k	2 w					306-123

Electrical Parts List—Type 160 Series

Resistors (Cont'd)

							Tektronix Part Number
R56		500 k	.2 w	Var.		Vert Gain Adj.	311-066
R57		12 k	2 w				306-123
R58		12 k	2 w				306-123
R60		1 k	1/2 w				302-102
R61		10 k	5 w		WW	5%	308-008
R62		1 k	1 w				304-102
R63		1.5 k	2 w				306-152
R70	101-131	47 Ω	1/2 w				302-470
R70	132-up	180 k	1/2 w				302-184
R71	101-131	47 Ω	1/2 w				302-470
R71	132-up	100 k	(Concentric with R46)			Vert. Pos.	311-064
R72A,B	101-131	150 k	2 w				306-154
R72	132-up	490 k	1/2 w		Prec.	1%	309-002
R73	101-131	5 k	.2 w	Var.			311-067
R73	132-up	750 k	1/2 w		Prec.	1%	309-010
R74	101-131X	82 k	1/2 w				302-823
R75	101-131	150 k	1/2 w				302-154
R75	132-up	666.6 k	1/2 w		Prec.	1%	309-007
R76	101-131	56 k	1/2 w				302-563
R76	132-up	39 k	1/2 w				302-393
R77	101-131	270 k	1/2 w				302-274
R77	132-up	5 k	.2 w	Var.		Sweep Cal.	311-067
R78	X132-up	47 Ω	1/2 w				302-470
R80	101-131X	470 k	1/2 w				302-474
R83	101-131	666.6 k	1/2 w		Prec.	1%	309-007
R83	132-up	1.2 meg	1/2 w		Prec.	1%	309-149
R84	101-131	608 k	1/2 w		Prec.	1%	309-005
R84	132-up	800 k	1/2 w		Prec.	1%	309-110
R85	101-131	970 k	1/2 w		Prec.	1%	309-012
R85	132-up	1.2 meg	1/2 w		Prec.	1%	309-149
R86	101-131	100 k	1/2 w				302-104
R86	132-up	47 k	1/2 w				302-473
R90		10 k	1/2 w				302-103
R91		270 k	1/2 w				302-274
R92		120 k	1/2 w				302-124
R100		1 meg	1/2 w				302-105
R103	X3370-up	56 k	2 w				306-563
R104	101-3369	47 k	2 w				306-473
R104	3370-up	68 k	2 w				306-683
R105		47 k	1/2 w				302-473
R106		1.5 k	1/2 w				302-152
R113	X132-up	180 k	1/2 w				302-184
R114	X132-up	56 k	1/2 w				302-563
R115		1 meg	1/2 w				302-105
R116	101-1929	100 k	1/2 w				302-104
R116	1930-up	56 k	1/2 w				302-563
R117		6.8 meg	2 w				306-685
R118		6.8 meg	2 w				306-685
R119	101-4459	1 meg	1/2 w	Var.		Intensity	311-041
R119	4460-up	1 meg	1/2 w	Var.		Intensity	311-0041-02
R120	101-131X	1.5 meg	1/2 w				302-155
R120	X317-up	3.9 meg	1/2 w			Use	302-395
R121		1.5 meg	1/2 w				302-155
R122	X1930-up	33 k	1/2 w				302-333

Resistors (continued)

							Tektronix Part Number
R130		1 k	1/2 w				302-102
R131		1 meg	1/2 w				302-105
R132		2 meg	2 w	Var.	H.V. Adj.		311-042
R133		3.9 meg	2 w				306-395
R134	101-4459	2 meg	2 w	Var.	Focus		311-043
R134	4460-up	2 meg	2 w	Var.	Focus		311-0043-02
R135		1.5 meg	1/2 w				302-155
R136		27 k	1/2 w				302-273
R138		50 k	2 w	Var.	Astigmatism		311-023
R140		270 Ω	1/2 w				302-271
R141		10 k	5 w		5%		308-008
R142		270 Ω	1/2 w				302-271
R145		27 k	2 w				306-273
R146		50 Ω	2 w	Var.	Scale Illum.		311-055

Switches

				Wired	Unwired
SW9	101-378	Toggle	AC-DC		260-134
	379-up	Toggle	AC-DC		260-014
SW10		Rotary	VOLTS/DIV	*262-098	*260-119
SW80	X132-up	Toggle	SAWTOOTH POLARITY		260-014

Transformers

T100		CRT Supply	T3150A2		*120-011
		Primary:	68-0-136 vac		
		Secondary:	1240 vac		
			1310 vac		
			2 heater windings		
T140		CRT Heater Isolating Transformer	T360FA1		*120-065
		Primary:	6.3 vac		
		Secondary:	6.3 vac, .6 amp		

Electron Tubes

V30	101-4009	6AU6			154-022
V30	4010-up	8425			154-0022-07
V32	101-4009	6AU6			154-022
V32	4010-up	8425			154-0022-07
V50		6EW6/6AU6			Use 154-212
V52		6EW6/6AU6			Use 154-212
V70	101-131X	6BQ7A			154-028
V72	X132-up	6AN8			154-078
V80	101-4009	6AU6			154-022
V80	4010-up	8425			154-0022-07
V100		12AT7			154-039
V104		6AQ5			154-017
V115		5642			154-051
V116		5642			154-051
	†101-2576	CRT T3100-2 Standard Phosphor			Use *154-363
	2577-up	CRT T3100-2 Standard Phosphor			*154-0363-00

†S/N 101-2576 add \*050-0141-00.





## FIGURE AND INDEX NUMBERS

Items in this section are referenced by figure and index numbers to the illustrations which appear on the pullout pages immediately following the Diagrams section of this instruction manual.

## INDENTATION SYSTEM

This mechanical parts list is indented to indicate item relationships. Following is an example of the indentation system used in the Description column.

*Assembly and/or Component*  
*Detail Part of Assembly and/or Component*  
*mounting hardware for Detail Part*  
*Parts of Detail Part*  
*mounting hardware for Parts of Detail Part*  
*mounting hardware for Assembly and/or Component*

Mounting hardware always appears in the same indentation as the item it mounts, while the detail parts are indented to the right. Indented items are part of, and included with, the next higher indentation.

**Mounting hardware must be purchased separately, unless otherwise specified.**

## PARTS ORDERING INFORMATION

Replacement parts are available from or through your local Tektronix, Inc. Field Office or representative.

Changes to Tektronix instruments are sometimes made to accommodate improved components as they become available, and to give you the benefit of the latest circuit improvements developed in our engineering department. It is therefore important, when ordering parts, to include the following information in your order: Part number, instrument type or number, serial or model number, and modification number if applicable.

If a part you have ordered has been replaced with a new or improved part, your local Tektronix, Inc. Field Office or representative will contact you concerning any change in part number.

Change information, if any, is located at the rear of this manual.

## ABBREVIATIONS AND SYMBOLS

For an explanation of the abbreviations and symbols used in this section, please refer to the page immediately preceding the Electrical Parts List in this instruction manual.

**INDEX OF MECHANICAL PARTS LIST ILLUSTRATIONS**  
**(Located behind diagrams)**

- FIG. 1 TYPE 160 MECHANICAL PARTS
- FIG. 2 TYPE 160A MECHANICAL PARTS
- FIG. 3 TYPE 161 MECHANICAL PARTS
- FIG. 4 TYPE 162 MECHANICAL PARTS
- FIG. 5 TYPE 163 MECHANICAL PARTS
- FIG. 6 TYPE 360 FRONT
- FIG. 7 TYPE 360 CHASSIS & REAR
- FIG. 8 TYPE 126 MECHANICAL PARTS & CABINET
- FIG. 9 STANDARD ACCESSORIES
- FIG. 10 STANDARD ACCESSORIES
- FIG. 11 STANDARD ACCESSORIES
- FIG. 12 STANDARD ACCESSORIES
- FIG. 13 STANDARD ACCESSORIES
- FIG. 14 STANDARD ACCESSORIES
- FIG. 15 STANDARD ACCESSORIES

# SECTION 6

## MECHANICAL PARTS LIST

FIG. 1 TYPE 160 MECHANICAL PARTS

Fig. & Index No.	Tektronix Part No.	Serial/Model Eff	No. Disc	Q					Description	
				t	y	1	2	3		4
1-1	333-0025-00			1						PANEL, front
	- - - - -			-						mounting hardware: (not included w/panel)
-2	211-0510-00			8						SCREW, 6-32 x $\frac{3}{8}$ inch, PHS
-3	210-0006-00			8						LOCKWASHER, internal, #6
-4	210-0407-00			8						NUT, hex., 6-32 x $\frac{1}{4}$ inch
	352-0002-00			1						ASSEMBLY, fuse holder
	- - - - -			-						assembly includes:
-5	352-0010-00			1						HOLDER, fuse, 3AG
-6	210-0873-00			1						WASHER, rubber, $\frac{1}{2}$ x $1\frac{1}{16}$ inch
-7	- - - - -			1						NUT, fuse holder
-8	200-0015-00			1						CAP, fuse
-9	136-0025-00			1						SOCKET, light, w/hardware
-10	378-0518-00			1						JEWEL, light, pilot
-11	260-0134-00			1						SWITCH, toggle—POWER ON
	- - - - -			-						switch includes:
	210-0414-00			1						NUT, hex., 15-32 x $\frac{9}{16}$ inch
	- - - - -			-						mounting hardware: (not included w/switch)
-12	210-0902-00			1						WASHER, flat, 0.470 ID x $2\frac{1}{32}$ inch OD
-13	210-0473-00			1						NUT, 12-sided, $1\frac{5}{32}$ -32 x $\frac{5}{64}$ inch
-14	441-0011-00			1						CHASSIS
	- - - - -			-						mounting hardware: (not included w/chassis)
-15	211-0538-00			6						SCREW, 6-32 x $\frac{5}{16}$ inch, 100° csk, FHS
-16	210-0006-00			6						LOCKWASHER, internal, #6
-17	210-0407-00			6						NUT, hex., 6-32 x $\frac{1}{4}$ inch
-18	- - - - -			1						TRANSFORMER
	- - - - -			-						transformer includes:
-19	212-0017-00			4						SCREW, 8-32 x 5 inch, HHS
	210-0008-00			4						LOCKWASHER, internal, #8
	- - - - -			-						mounting hardware: (not included w/transformer)
-20	210-0008-00			4						LOCKWASHER, internal, #8
-21	210-0409-00			4						NUT, hex., 8-32 x $\frac{5}{16}$ inch
-22	210-0205-00			2						LUG, solder, SE #8
	- - - - -			-						mounting hardware for each: (not included w/lug)
-23	210-0409-00			1						NUT, hex., 8-32 x $\frac{5}{16}$ inch
-25	136-0011-00	101	323	3						SOCKET, tube, 8 pin, w/ground lugs
	136-0011-00	324		4						SOCKET, tube, 8 pin, w/ground lugs
	- - - - -			-						mounting hardware for each: (not included w/socket)
-25	211-0507-00			2						SCREW, 6-32 x $\frac{5}{16}$ inch, PHS
-26	210-0006-00			2						LOCKWASHER, internal, #6
-27	210-0407-00			2						NUT, hex., 6-32 x $\frac{1}{4}$ inch

Mechanical Parts List—Type 160 Series

FIG. 1 TYPE 160 MECHANICAL PARTS (cont)

Fig. & Index No.	Tektronix Part No.	Serial/Model Eff	No. Disc	Q					Description	
				t	Y	1	2	3		4
1-28	136-0008-00			3						SOCKET, tube, 7 pin, w/ground lugs - mounting hardware for each: (not included w/socket)
-29	211-0008-00			2						SCREW, 4-40 x 1/4 inch, PHS
-30	210-0004-00			2						LOCKWASHER, internal, #4
-31	210-0406-00			2						NUT, hex., 4-40 x 3/16 inch
-32	136-0015-00			1						SOCKET, tube, 9 pin, w/ground lugs - mounting hardware: (not included w/socket)
-33	211-0008-00			2						SCREW, 4-40 x 1/4 inch, PHS
	210-0004-00			2						LOCKWASHER, internal, #4
-34	210-0406-00			2						NUT, hex., 4-40 x 3/16 inch
-35	- - - - -			2						RESISTOR, variable - mounting hardware for each: (not included w/resistor)
-36	210-0840-00			1						WASHER, flat, 0.390 ID x 9/16 inch OD
-37	210-0413-00			1						NUT, hex., 3/8-32 x 1/2 inch
-38	385-0016-00			1						ROD, plastic, 5/16 x 1 inch, tapped 6-32 thru - mounting hardware: (not included w/rod)
-39	211-0507-00			1						SCREW, 6-32 x 5/16 inch, PHS
-40	210-0005-00			1						LOCKWASHER, external, #6
-41	210-0204-00			1						LUG, solder, DE #6 - mounting hardware: (not included w/lug)
-42	211-0507-00			1						SCREW, 6-32 x 5/16 inch, PHS
-43	136-0013-00			4						SOCKET, tube, 8 pin - mounting hardware for each: (not included w/socket)
-44	211-0538-00			2						SCREW, 6-32 x 5/16 inch, 100° csk, FHS
-45	210-0006-00			2						LOCKWASHER, internal, #6
-46	210-0407-00			2						NUT, hex., 6-32 x 1/4 inch
-47	210-0202-00			2						LUG, solder, SE #6
-48	131-0010-00			1						CONNECTOR, motor base, 2-contact - mounting hardware: (not included w/connector)
-49	211-0538-00			2						SCREW, 6-32 x 5/16 inch, 100° csk, FHS
	210-0006-00			2						LOCKWASHER, internal, #6
-50	210-0407-00			2						NUT, hex., 6-32 x 1/4 inch

FIG. 1 TYPE 160 MECHANICAL PARTS (cont)

Fig. & Index No.	Tektronix Part No.	Serial/Model Eff	No. Disc	Q t y	Description				
					1	2	3	4	5
1-51	- - - - -			1	CAPACITOR				
				-	mounting hardware: (not included w/capacitor)				
-52	386-0255-00			1	PLATE, metal, large				
-53	211-0507-00			2	SCREW, 6-32 x $\frac{5}{16}$ inch, PHS				
	210-0006-00			2	LOCKWASHER, internal, #6				
-54	210-0407-00			2	NUT, hex., 6-32 x $\frac{1}{4}$ inch				
-55	- - - - -			1	CAPACITOR				
				-	mounting hardware: (not included w/capacitor)				
-56	386-0252-00			1	PLATE, fiber, small				
-57	211-0507-00			2	SCREW, 6-32 x $\frac{5}{16}$ inch, PHS				
-58	210-0006-00			2	LOCKWASHER, internal, #6				
-59	210-0407-00			2	NUT, hex., 6-32 x $\frac{1}{4}$ inch				
-60	200-0057-00			1	COVER, capacitor, $1\frac{1}{8}$ x $3\frac{1}{8}$ inches				
-61	387-0520-00			1	PLATE, left side				
-62	387-0521-00			1	PLATE, right side				
-63	387-0522-00			1	PLATE, rear				
				-	plate includes:				
-64	214-0024-00			1	FASTENER, spring cowl, #5				
				-	mounting hardware: (not included w/plate)				
-65	211-0538-00			4	SCREW, 6-32 x $\frac{5}{16}$ inch, 100° csk, FHS				
-66	210-0006-00			4	LOCKWASHER, internal, #6				
-67	210-0407-00			4	NUT, hex., 6-32 x $\frac{1}{4}$ inch				
-68	179-0037-00			1	CABLE HARNESS				

FIG. 2 TYPE 160A MECHANICAL PARTS

Fig. & Index No.	Tektronix Part No.	Serial/Model Eff	No. Disc	Q					Description	
				†	y	1	2	3		4
2-1	333-0134-00			1						PANEL, front
-2	136-0027-00			1						SOCKET, light, w/green jewel & hardware
-3	260-0134-00			1						SWITCH, toggle—POWER ON
-4	210-0414-00			1						NUT, hex., $1\frac{5}{32}$ -32 x $\frac{9}{16}$ inch
-5	210-0902-00			1						WASHER, flat, 0.470 ID x $2\frac{1}{32}$ inch OD
-6	210-0473-00			1						NUT, $1\frac{5}{32}$ -32 x $\frac{5}{64}$ inch, 12 sided
	352-0002-00			1						ASSEMBLY, fuse holder
-7	352-0010-00			1						HOLDER, fuse
-8	200-0582-00			1						CAP, fuse holder
-9	210-0873-00			1						WASHER, rubber, $\frac{1}{2}$ ID x $1\frac{1}{16}$ inch OD
-10				1						NUT, fuse holder
-11				2						RESISTOR, variable
-12	210-0494-00			1						NUT, hex., $\frac{3}{8}$ -32 x $\frac{1}{2}$ x $1\frac{1}{16}$ inch
-13	210-0013-00			1						LOCKWASHER, internal, $\frac{3}{8}$ x $1\frac{1}{16}$ inch
-14	358-0010-00			1						BUSHING
-15	136-0008-00			2						SOCKET, tube, 7 pin, w/ground lugs
-16	211-0033-00			2						SCREW, sems, 4-40 x $\frac{5}{16}$ inch, PHS
-17	210-0004-00			2						LOCKWASHER, internal, #4
-18	210-0406-00			2						NUT, hex., 4-40 x $\frac{3}{16}$ inch
-19	136-0015-00			4						SOCKET, tube, 9 pin, w/ground lugs
-20	211-0033-00			2						SCREW, sems, 4-40 x $\frac{5}{16}$ inch, PHS
-21	210-0004-00			2						LOCKWASHER, internal, #4
-22	210-0406-00			2						NUT, hex., 4-40 x $\frac{3}{16}$ inch
-23	136-0011-00			4						SOCKET, tube, 8 pin, w/ground lugs
-24	211-0538-00			2						SCREW, 6-32 x $\frac{5}{16}$ inch, 100° csk, FHS
-25	210-0006-00			2						LOCKWASHER, internal, #6
-26	210-0407-00			2						NUT, hex., 6-32 x $\frac{1}{4}$ inch
-27	381-0044-00			1						BAR, frame
-28	212-0045-00			2						SCREW, 8-32 x $\frac{1}{2}$ inch, THS

FIG. 2 TYPE 160A MECHANICAL PARTS (cont)

Fig. & Index No.	Tektronix Part No.	Serial/Model Eff	No. Disc	Q † y	Description				
					1	2	3	4	5
2-29	381-0043-00	620	7139	1	BAR, right frame				
	381-0044-00	7140		1	BAR, frame				
	- - - - -			-	mounting hardware: (not included w/bar)				
-30	212-0045-00			2	SCREW, 8-32 x 1/2 inch, THS				
-31	- - - - -			1	CAPACITOR				
	- - - - -			-	mounting hardware: (not included w/capacitor)				
-32	211-0534-00			2	SCREW, sems, 6-32 x 5/16 inch, PHS				
-33	386-0255-00			1	PLATE, fiber, small				
-34	210-0006-00			2	LOCKWASHER, internal, #6				
-35	210-0407-00			2	NUT, hex., 6-32 x 1/4 inch				
-36	- - - - -			1	CAPACITOR				
	- - - - -			-	mounting hardware: (not included w/capacitor)				
-37	211-0534-00			2	SCREW, sems, 6-32 x 5/16 inch, PHS				
-38	386-0252-00			1	PLATE, metal, large				
-39	210-0006-00			2	LOCKWASHER, internal, #6				
-40	210-0407-00			2	NUT, hex., 6-32 x 1/4 inch				
-41	343-0002-00			1	CLAMP, cable, plastic, 3/16 inch				
	- - - - -			-	mounting hardware: (not included w/clamp)				
-42	211-0510-00			1	SCREW, 6-32 x 3/8 inch, PHS				
-43	210-0803-00			1	WASHER, flat, 0.150 ID x 3/8 inch OD				
-44	- - - - -			1	TRANSFORMER				
	- - - - -			-	transformer includes:				
-45	212-0540-00			4	SCREW, 10-32 x 5 1/2 inches, HHS				
-46	210-0812-00			4	WASHER, fiber, #10				
	- - - - -			-	mounting hardware: (not included w/transformer)				
-47	210-0564-00			4	NUT, hex., 10-32 x 3/8 inch				
-48	147-0008-00			1	MOTOR, fan				
	- - - - -			-	mounting hardware: (not included w/motor)				
-49	212-0507-00			2	SCREW, 10-32 x 3/8 inch, PHS				
-50	381-0045-00			1	BAR, motor				
	- - - - -			-	mounting hardware: (not included w/bar)				
-51	212-0008-00			2	SCREW, 8-32 x 1/2 inch, PHS				
-52	136-0013-00			2	SOCKET, tube, 8 pin				
	- - - - -			-	mounting hardware for each: (not included w/socket)				
-53	211-0534-00			2	SCREW, sems, 6-32 x 5/16 inch, PHS				
-54	210-0006-00			2	LOCKWASHER, internal, #6				
-55	210-0407-00			2	NUT, hex., 6-32 x 1/4 inch				

FIG. 2 TYPE 160A MECHANICAL PARTS (cont)

Fig. & Index No.	Tektronix Part No.	Serial/Model Eff	No. Disc	Q † y	1 2 3 4 5					Description
					1	2	3	4	5	
2-56	136-0013-00			2						SOCKET, tube, 8 pin
	- - - - -			-						mounting hardware for each: (not included w/socket)
-57	211-0534-00			2						SCREW, sems, 6-32 x 5/16 inch, PHS
-58	210-0006-00			1						LOCKWASHER, internal, #6
-59	210-0202-00			1						LUG, solder, SE #6
-60	210-0407-00			1						NUT, hex., 6-32 x 1/4 inch
	131-0010-00	101	3056	1						CONNECTOR, motor base, 2 conductor
	131-0102-00	3057		1						ASSEMBLY, motor base, 3 conductor
	- - - - -			-						assembly includes:
-61	129-0041-00			1						POST, ground
-62	211-0015-00			1						SCREW, 4-40 x 1/2 inch, RHS
-63	200-0185-00			1						COVER, plastic
-64	214-0078-00			2						PIN, connecting
-65	377-0041-00			1						INSERT, plastic
-66	386-0933-00			1						PLATE
	210-0003-00			2						LOCKWASHER, external, #4
-67	210-0551-00			2						NUT, hex., 4-40 x 1/4 inch
	- - - - -			-						mounting hardware: (not included w/assembly)
-68	211-0538-00			2						SCREW, 6-32 x 5/16 inch, 100° csk, FHS
-69	210-0006-00			2						LOCKWASHER, internal, #6
-70	210-0407-00			2						NUT, hex., 6-32 x 1/4 inch, THS
-71	441-0097-00			1						CHASSIS
	- - - - -			-						mounting hardware: (not included w/chassis)
-72	212-0045-00			2						SCREW, 8-32 x 1/2 inch, THS
-73	210-0804-00			2						WASHER, flat, 0.170 ID x 3/8 inch OD
-74	210-0458-00			2						NUT, keps, 8-32 x 1 1/32 inch
-75	211-0510-00			2						SCREW, 6-32 x 3/8 inch, PHS
-76	210-0803-00			2						WASHER, flat, 0.150 ID x 3/8 inch OD
-77	210-0006-00			2						LOCKWASHER, internal, #6
-78	210-0407-00			2						NUT, hex., 6-32 x 1/4 inch
-79	200-0257-00			1						COVER, capacitor, 1 inch diameter x 2 17/32 inches
-80	387-0542-00			1						PLATE, frame, back
	- - - - -			-						plate includes:
-81	214-0024-00			1						FASTENER
	- - - - -			-						mounting hardware: (not included w/plate)
-82	211-0538-00			4						SCREW, 6-32 x 5/16 inch, 100° csk, FHS
-83	210-0457-00			2						NUT, keps, 6-32 x 5/16 inch
-84	179-0083-00			1						CABLE HARNESS, #1
-85	179-0084-00			1						CABLE HARNESS, #2



FIG. 2 TYPE 160A MECHANICAL PARTS (cont)

Fig. & Index No.	Tektronix Part No.	Serial/Model Eff	No. Disc	Q † y	Description					
					1	2	3	4	5	
2-86	124-0014-00	620	3289	2	STRIP, ceramic, 3/4 inch h, w/7 notches					
	124-0089-00	3290		2	STRIP, ceramic, 3/4 inch h, w/7 notches					
	- - - - -	-		-	each strip includes:					
	355-0046-00	X3290		2	STUD, plastic					
	- - - - -	-		-	mounting hardware for each: (not included w/strip)					
	210-0850-00	620		3289	2	WASHER, flat 0.093 ID x 9/32 inch OD				
	210-0002-00	620		3289	2	LOCKWASHER, external, #2				
	210-0405-00	620		3289	2	NUT, hex., 2-56 x 3/16 inch				
361-0009-00	3290		2	SPACER, plastic, 0.406 inch long						
-87	124-0016-00	620	3289	2	STRIP, ceramic, 3/4 inch h, w/11 notches					
	124-0091-00	3290		2	STRIP, ceramic, 3/4 inch h, w/11 notches					
	- - - - -	-		-	each strip includes:					
	355-0046-00	X3290		2	STUD, plastic					
	- - - - -	-		-	mounting hardware for each: (not included w/strip)					
	210-0850-00	620		3289	2	WASHER, flat, 0.093 ID x 9/32 inch OD				
	210-0002-00	620		3289	2	LOCKWASHER, external, #2				
	210-0405-00	620		3289	2	NUT, hex., 2-56 x 3/16 inch				
361-0009-00	3290		2	SPACER, plastic, 0.406 inch long						
-88	437-0029-00	620	4399	1	CABINET, blue wrinkle					
	437-0052-00	4400		1	CABINET, blue vinyl					
- - - - -	-	-	-	cabinet includes:						
-89	355-0028-00			1	STUD					
	384-0517-00			1	ROD, pin					
-90	334-0649-00			1	TAG, voltage					
- - - - -	-	-	-	mounting hardware: (not included w/tag)						
-91	213-0088-00			2	SCREW, thread forming, #4 x 1/4 inch, PHS					
-92	369-0008-00			1	FAN					

FIG. 3 TYPE 161 MECHANICAL PARTS

Fig. & Index No.	Tektronix Part No.	Serial/Model No. Eff Disc	Q † Y	Description					
				1	2	3	4	5	
3-1	333-0027-00 333-0294-00	101 1376	1375	1	PANEL, front				
				1	PANEL, front				
-2	366-0506-00 366-0522-00 366-0525-00 366-0525-01 - - - - - 213-0006-00 213-0004-00	101 1807 4055 11590 - - - - - 101 11590	1806 4054 11589	1 1 1 1 - 1 2	KNOB, dial assembly—PULSE WIDTH MULTIPLIER KNOB, dial assembly—PULSE WIDTH MULTIPLIER KNOB, dial assembly—PULSE WIDTH MULTIPLIER KNOB, dial assembly—PULSE WIDTH MULTIPLIER knob includes: SCREW, set, 8-32 x 3/16 inch, HSS SCREW, set, 6-32 x 3/16 inch, HSS				
-3	- - - - -	- - - - -	- - - - -	2	RESISTOR, variable mounting hardware for each: (not included w/resistor)				
-4	210-0012-00			1	LOCKWASHER, internal, 3/8 ID x 1/2 inch OD				
-5	210-0840-00			1	WASHER, flat, 0.390 ID x 9/16 inch OD				
-6	210-0590-00			1	NUT, hex., 3/8-32 x 7/16 inch				
-7	366-0007-00 366-0117-00 - - - - - 213-0006-00 213-0004-00	101 11590 - - - - - 101 11590	11589	1 1 - 1 1	KNOB, black—OUTPUT PULSE DELAY KNOB, charcoal—OUTPUT PULSE DELAY knob includes: SCREW, set, 8-32 x 3/16 inch, HSS SCREW, set, 6-32 x 3/16 inch, HSS				
-8	366-0007-00 366-0117-00 - - - - - 213-0006-00 213-0004-00	101 11590 - - - - - 101 11590	11589	1 1 - 1 1	KNOB, black—PULSE WIDTH KNOB, charcoal—PULSE WIDTH knob includes: SCREW, set, 8-32 x 3/16 inch, HSS SCREW, set, 6-32 x 3/16 inch, HSS				
-9	262-0011-00 262-0620-00 - - - - - 260-0030-00 - - - - -	101 7740 - - - - - - - - - -	7739	1 1 - 1 -	SWITCH, wired—PULSE WIDTH SWITCH, wired—PULSE WIDTH switch includes: SWITCH, unwired mounting hardware: (not included w/switch)				
-10	210-0012-00			1	LOCKWASHER, internal, 3/8-32 x 7/16 inch				
-11	210-0840-00			1	WASHER, flat, 0.390 ID x 9/16 inch OD				
-12	210-0413-00			1	NUT, hex., 3/8-32 x 1/2 inch				
-13	366-0007-00 366-0117-00 - - - - - 213-0006-00 213-0004-00	101 11590 - - - - - 101 11590	11589	1 1 - 1 1	KNOB, black—PULSE AMPLITUDE KNOB, charcoal—PULSE AMPLITUDE knob includes: SCREW, set, 8-32 x 3/16 inch, HSS SCREW, set, 6-32 x 3/16 inch, HSS				
-14	- - - - -	- - - - -	- - - - -	1	RESISTOR, variable mounting hardware: (not included w/resistor)				
-15	210-0013-00			1	LOCKWASHER, internal, 3/8 ID x 1 1/16 inch OD				
-16	210-0840-00			1	WASHER, flat, 0.390 ID x 9/16 inch OD				
-17	210-0590-00			1	NUT, hex., 3/8-32 x 7/16 inch				
-18	260-0014-00 - - - - -			1 -	SWITCH, toggle—TRIGGER SELECTOR mounting hardware: (not included w/switch)				
-19	210-0414-00			1	NUT, hex., 15/32-32 x 9/16 inch				
-20	354-0055-00			1	RING, locking				
-21	210-0902-00			1	WASHER, flat, 0.470 ID x 2 1/32 inch OD				
-22	210-0473-00			1	NUT, 12 sided, 15/32-32 x 0.634 inch				

FIG. 3 TYPE 161 MECHANICAL PARTS (cont)

Fig. & Index No.	Tektronix Part No.	Serial/Model Eff	No. Disc	Q					Description
				t	1	2	3	4	
3-23	260-0014-00			1					SWITCH, toggle—PULSE POLARITY
	- - - - -			-					mounting hardware: (not included w/switch)
-24	210-0414-00			1					NUT, hex., $1\frac{5}{32}$ -32 x $\frac{9}{16}$ inch
-25	210-0902-00			1					WASHER, flat, 0.470 ID x $2\frac{1}{32}$ inch OD
-26	210-0473-00			1					NUT, 12 sided, $1\frac{5}{32}$ -32 x 0.634 inch
-27	- - - - -			2					RESISTOR, variable
	- - - - -			-					mounting hardware for each: (not included w/resistor)
-28	210-0494-00			1					NUT, hex., $\frac{3}{8}$ -32 x $\frac{1}{2}$ x $1\frac{1}{16}$ inch
-29	210-0013-00			1					LOCKWASHER, internal, $\frac{3}{8}$ ID x $1\frac{1}{16}$ inch OD
-30	358-0010-00			1					BUSHING
-31	- - - - -			1					RESISTOR, variable
	- - - - -			-					mounting hardware: (not included w/resistor)
-32	210-0207-00			1					LUG, solder, $\frac{3}{8}$ ID x $\frac{5}{8}$ inch OD, SE
-33	210-0012-00			1					LOCKWASHER, internal, $\frac{3}{8}$ ID x $\frac{1}{2}$ inch OD
-34	210-0429-00			1					NUT, hex., $\frac{3}{8}$ -32 x $\frac{1}{2}$ x $1\frac{1}{16}$ inches
-35	210-0013-00			1					LOCKWASHER, internal, $\frac{3}{8}$ ID x $\frac{1}{2}$ inch OD
-36	358-0010-00			1					BUSHING
-37	386-0294-00	101	1375	1					PLATE, sub-panel, front
	386-0581-00	1376		1					PLATE, sub-panel, front
-38	129-0020-00	X1376		2					ASSEMBLY, binding post
	- - - - -			-					assembly includes:
	355-0503-00			1					STEM
	200-0072-00			1					CAP
	- - - - -			-					mounting hardware for each: (not included w/assembly)
-39	220-0410-00			1					NUT, keps, 10-32 x $\frac{3}{8}$ inch
-40	129-0030-00	101	1375	4					POST, binding
	129-0030-00	1376	2912	3					POST, binding
	129-0036-00	2913	11589	3					POST, binding
	129-0063-00	11590		3					POST, binding
	- - - - -			-					mounting hardware for each: (not included w/post)
-41	358-0036-00	101	11589	1					BUSHING, plastic
	358-0169-00	11590		1					BUSHING, plastic
	210-0445-00	101	7869	2					NUT, hex., 10-32 x $\frac{3}{8}$ inch
	210-0206-00	101	7869	1					LUG, solder, SE #10 long
-42	220-0410-00	7870		1					NUT, keps, 10-32 x $\frac{3}{8}$ inch
-43	129-0020-00	X1376		1					ASSEMBLY, binding post
	- - - - -			-					assembly includes:
	355-0503-00			1					STEM
	200-0072-00			1					CAP
	- - - - -			-					mounting hardware: (not included w/assembly)
-44	210-0206-00			1					LUG, solder, SE #10
-45	220-0410-00			1					NUT, keps, 10-32 x $\frac{3}{8}$ inch

FIG. 3 TYPE 161 MECHANICAL PARTS (cont)

Fig. & Index No.	Tektronix Part No.	Serial/Model No.		Q † Y	Description
		Eff	Disc		
3-46	136-0015-00			4	SOCKET, tube, 9 pin, w/ground lugs
	- - - - -			-	mounting hardware for each: (not included w/socket)
	211-0033-00	101	5369	2	SCREW, sems, 4-40 x 5/16 inch, PHS
	210-0004-00	101	5369	2	LOCKWASHER, internal, #4
	210-0406-00	101	5369	2	NUT, hex., 4-40 x 3/16 inch
-47	213-0044-00	5370		2	SCREW, thread forming, 5-32 x 3/16 inch, PHS
-48	385-0135-00			3	ROD, plastic, 5/16 inch x 15/16 inch
	- - - - -			-	mounting hardware for each: (not included w/rod)
-49	213-0041-00			1	SCREW, thread cutting, 6-32 x 3/8 inch, THS
-50	- - - - -			1	CAPACITOR
	- - - - -			-	mounting hardware: (not included w/capacitor)
-51	211-0534-00			2	SCREW, sems, 6-32 x 5/16 inch, PHS
-52	210-0202-00			1	LUG, solder, SE #6
-53	386-0253-00			1	PLATE, metal, small
-54	210-0006-00			1	LOCKWASHER, internal, #6
-55	210-0407-00			2	NUT, hex., 6-32 x 1/4 inch
-56	- - - - -			1	RESISTOR
	- - - - -			-	mounting hardware: (not included w/resistor)
-57	211-0507-00			1	SCREW, 6-32 x 5/16 inch, PHS
-58	210-0478-00			1	NUT, hex., 5/16 x 2 1/32 inch long
-59	211-0544-00			1	SCREW, 6-32 x 3/4 inch, THS
-60	- - - - -			3	CAPACITOR
	- - - - -			-	mounting hardware for each: (not included w/capacitor)
-61	211-0013-00			2	SCREW, 4-40 x 3/8 inch, RHS
	210-0004-00			2	LOCKWASHER, internal, #4
-62	210-0406-00			2	NUT, hex., 4-40 x 3/16 inch
-63	385-0071-00			1	ROD, plastic, 5/16 x 15/16 inch, w/pin
	- - - - -			-	mounting hardware: (not included w/rod)
-64	211-0507-00			1	SCREW, 6-32 x 5/16 inch, PHS
-65	- - - - -			1	COIL
	- - - - -			-	mounting hardware: (not included w/coil)
-66	211-0507-00			1	SCREW, 6-32 x 5/16 inch, PHS
-67	210-0204-00			1	LUG, solder, DE #6
	- - - - -			-	mounting hardware: (not included w/lug)
-68	210-0504-00			1	SCREW, 6-32 x 1/4 inch, PHS
-69	348-0002-00			1	GROMMET, rubber, 1/4 inch diameter
-70	- - - - -			2	RESISTOR, variable
	- - - - -			-	mounting hardware for each: (not included w/resistor)
	210-0840-00			1	WASHER, flat, 0.390 ID x 7/16 inch OD
-71	210-0590-00			1	NUT, hex., 3/8-32 x 7/16 inch

FIG. 3 TYPE 161 MECHANICAL PARTS (cont)

Fig. & Index No.	Tektronix Part No.	Serial/Model Eff	No. Disc	Q † y	Description				
					1	2	3	4	5
3-72	441-0012-00	101	3193	1	CHASSIS				
	441-0267-00	3194		1	CHASSIS				
	- - - - -			-	mounting hardware: (not included w/chassis)				
-73	211-0538-00			4	SCREW, 6-32 x 5/16 inch, 100° csk, FHS				
-74	210-0202-00			1	LUG, solder, SE #6				
-75	210-0457-00			4	NUT, keps, 6-32 x 5/16 inch				
-76	134-0006-00			1	PLUG, 8 pin				
	- - - - -			-	mounting hardware: (not included w/plug)				
-77	211-0507-00			2	SCREW, 6-32 x 5/16 inch, PHS				
-78	386-0251-00			1	PLATE				
-79	354-0002-00			1	RING, retaining				
-80	210-0803-00			2	WASHER, flat, 0.150 ID x 3/8 inch OD				
-81	210-0457-00			2	NUT, keps, 6-32 x 5/16 inch				
-82	426-0019-00			1	FRAME				
	- - - - -			-	frame includes:				
-83	214-0024-00			1	FASTENER, spring				
	- - - - -			-	mounting hardware: (not included w/frame)				
-84	211-0538-00			4	SCREW, 6-32 x 5/16 inch, 100° csk, FHS				
-85	210-0457-00			4	NUT, keps, 6-32 x 5/16 inch				
-86	136-0013-00			1	SOCKET, tube, 8 pin				
	- - - - -			-	mounting hardware: (not included w/socket)				
-87	211-0507-00			2	SCREW, 6-32 x 5/16 inch, PHS				
-88	210-0457-00			2	NUT, keps, 6-32 x 5/16 inch				
-89	136-0008-00	101	3193	1	SOCKET, tube, 7 pin, w/ground lugs				
	136-0015-00	3194		1	SOCKET, tube, 9 pin, w/ground lugs				
	- - - - -			-	mounting hardware: (not included w/socket)				
	211-0033-00	101	5369	2	SCREW, sems, 4-40 x 5/16 inch, PHS				
	210-0004-00	101	5369	2	LOCKWASHER, internal, #4				
	210-0406-00	101	5369	2	NUT, hex., 4-40 x 3/16 inch				
-90	213-0044-00	5370		2	SCREW, thread forming, 5-32 x 3/16 inch, PHS				

FIG. 4 TYPE 162 MECHANICAL PARTS

Fig. & Index No.	Tektronix Part No.	Serial/Model No.		Q t y	Description
		Eff	Disc		
1 2 3 4 5					
4-1	333-0029-00	101	1610	1	PANEL, front
	333-0295-00	1611		1	PANEL, front
-2	366-0007-00	101	12939	1	KNOB, black—OPERATING MODE
	366-0117-00	12940		1	KNOB, charcoal—OPERATING MODE
	- - - - -			-	knob includes:
	213-0006-00	101	12939	1	SCREW, set, 8-32 x 3/16 inch, HSS
	213-0004-00	12940		1	SCREW, set, 6-32 x 3/16 inch, HSS
-3	262-0013-00			1	SWITCH, wired—OPERATING MODE
	- - - - -			-	switch includes:
	260-0044-00			1	SWITCH, unwired
	- - - - -			-	mounting hardware: (not included w/switch)
-4	210-0012-00			1	LOCKWASHER, internal, 3/8 ID x 1/2 inch OD
	210-0840-00			1	WASHER, flat, 0.390 ID x 7/16 inch OD
	210-0590-00			1	NUT, hex., 3/8-32 x 7/16 inch
-5	366-0007-00	101	12939	1	KNOB, black—VERNIER
	366-0117-00	12940		1	KNOB, charcoal—VERNIER
	- - - - -			-	knob includes:
	213-0006-00	101	12939	1	SCREW, set, 8-32 x 3/16 inch, HSS
	213-0004-00	12940		1	SCREW, set, 6-32 x 3/16 inch, HSS
-6	- - - - -			1	RESISTOR, variable
	- - - - -			-	mounting hardware: (not included w/resistor)
-7	210-0207-00			1	LUG, solder, SE #6
-8	210-0012-00			1	LOCKWASHER, internal, 3/8 ID x 1/2 inch OD
-9	210-0840-00			1	WASHER, flat, 0.390 ID x 7/16 inch OD
-10	210-0590-00			1	NUT, hex., 3/8-32 x 7/16 inch
-11	366-0007-00	101	12939	1	KNOB, black—WAVEFORM DURATION OR PULSE INTERVAL
	366-0117-00	12940		1	KNOB, charcoal—WAVEFORM DURATION OR PULSE INTERVAL
	- - - - -			-	knob includes:
	213-0006-00	101	12939	1	SCREW, set, 8-32 x 3/16 inch, HSS
	213-0004-00	12940		1	SCREW, set, 6-32 x 3/16 inch, HSS
-12	262-0014-00			1	SWITCH, wired—WAVEFORM DURATION OR PULSE INTERVAL
	- - - - -			-	switch includes:
	260-0024-00			1	SWITCH, unwired
	- - - - -			-	mounting hardware: (not included w/switch)
-13	210-0012-00			1	LOCKWASHER, internal, 3/8 ID x 1/2 inch OD
-14	210-0840-00			1	WASHER, flat, 0.390 ID x 7/16 inch OD
-15	210-0590-00			1	NUT, hex., 3/8-32 x 7/16 inch
-16	366-0007-00	101	12939	1	KNOB, black—MULTIPLIER
	366-0117-00	12940		1	KNOB, charcoal—MULTIPLIER
	- - - - -			-	knob includes:
	213-0006-00	101	12939	1	SCREW, set, 8-32 x 3/16 inch, HSS
	213-0004-00	12940		1	SCREW, set, 6-32 x 3/16 inch, HSS

FIG. 4 TYPE 162 MECHANICAL PARTS (cont)

Fig. & Index No.	Tektronix Part No.	Serial/Model Eff	No. Disc	Q † y	Description				
					1	2	3	4	5
4-17	262-0012-00			1	SWITCH, wired—MULTIPLIER				
	- - - - -			-	switch includes:				
	260-0038-00			1	SWITCH, unwired				
	- - - - -			-	mounting hardware: (not included w/switch)				
-18	210-0012-00			1	LOCKWASHER, internal, 3/8 ID x 1/2 inch OD				
-19	210-0840-00			1	WASHER, flat, 0.390 ID x 7/16 inch OD				
-20	210-0590-00			1	NUT, hex., 3/8-32 x 7/16 inch				
-21	386-0295-00	101	1610	1	PLATE, sub-panel, front				
	386-0582-00	1611		1	PLATE, sub-panel, front				
-22	- - - - -			1	RESISTOR, variable				
	- - - - -			-	mounting hardware: (not included w/resistor)				
-23	210-0494-00			1	NUT, hex., 3/8-32 x 1 1/16 inch long				
-24	210-0013-00			1	LOCKWASHER, internal, 3/8 ID x 1 1/16 inch OD				
-25	358-0010-00			1	BUSHING				
-26	260-0017-00			1	SWITCH, pushbutton—MANUAL				
	- - - - -			-	mounting hardware: (not included w/switch)				
-27	210-0840-00			1	WASHER, flat, 0.390 ID x 7/16 inch OD				
-28	210-0590-00			1	NUT, hex., 3/8-32 x 7/16 inch				
-29	210-0202-00			2	LUG, solder, SE #6				
	- - - - -			-	mounting hardware for each: (not included w/lug)				
-30	211-0503-00			1	SCREW, 6-32 x 3/16 inch, PHS				
-31	260-0014-00			1	SWITCH, toggle—GATE OUT—PULSE OUT				
	- - - - -			-	mounting hardware: (not included w/switch)				
-32	210-0414-00			1	NUT, hex., 1 5/32-32 x 7/16 inch				
-33	354-0055-00			1	RING, locking				
-34	210-0902-00			1	WASHER, flat, 0.470 ID x 2 1/32 inch OD				
-35	210-0473-00			1	NUT, 12 sided, 1 5/32-32 x 0.634 inch				
-36	129-0020-00	X1611		1	ASSEMBLY, binding post				
	- - - - -			-	assembly includes:				
	355-0503-00			1	STEM				
	200-0072-00			1	CAP				
	- - - - -			-	mounting hardware: (not included w/assembly)				
-37	210-0206-00			1	LUG, solder, SE #10 long				
-38	220-0410-00			1	NUT, keps, 10-32 x 3/8 inch				
-39	129-0030-00	101	1610	5	POST, binding				
	129-0030-00	1611	3524	4	POST, binding				
	129-0036-00	3525	12939	4	POST, binding				
	129-0063-00	12940		4	POST, binding				
	- - - - -			-	mounting hardware for each: (not included w/post)				
-40	358-0036-00	101	12939	1	BUSHING				
	358-0169-00	12940		1	BUSHING				
	210-0445-00	101	9239	2	NUT, hex., 10-32 x 3/8 inch				
	210-0010-00	101	9239	1	LOCKWASHER, internal, #10				
	210-0206-00	101	9239	1	LUG, solder, SE #10 long				
-41	220-0410-00	9240		1	NUT, keps, 10-32 x 3/8 inch				

Mechanical Parts List—Type 160 Series

FIG. 4 TYPE 162 MECHANICAL PARTS (cont)

Fig. & Index No.	Tektronix Part No.	Serial/Model No. Eff	No. Disc	Q					Description	
				t	Y	1	2	3		4
4-42	129-0020-00	X1611		2						ASSEMBLY, binding post - assembly includes:
	355-0503-00			1						STEM
	200-0072-00			1						CAP
				-						mounting hardware for each: (not included w/assembly)
-43	220-0410-00			1						NUT, keps, 10-32 x 3/8
-44	136-0008-00			1						SOCKET, tube, 7 pin, w/ground lugs - mounting hardware: (not included w/socket)
	211-0033-00	101	6370	2						SCREW, sems, 4-40 x 5/16 inch, PHS
	210-0004-00	101	6370	2						LOCKWASHER, internal, #4
	210-0406-00	101	6370	2						NUT, hex., 6-32 x 1/4 inch
-45	213-0044-00	6371		2						SCREW, thread forming, 5-32 x 3/16 inch, PHS
-46	136-0015-00			5						SOCKET, tube, 9 pin, w/ground lugs - mounting hardware for each: (not included w/socket)
	211-0033-00	101	6370	2						SCREW, sems, 4-40 x 5/16 inch, PHS
	210-0004-00	101	6370	2						LOCKWASHER, internal, #4
	210-0406-00	101	6370	2						NUT, hex., 4-40 x 3/16 inch
-47	213-0044-00	6371		2						SCREW, thread forming, 5-32 x 3/16 inch, PHS
-48				1						CAPACITOR - mounting hardware: (not included w/capacitor)
-49	211-0534-00			2						SCREW, sems, 6-32 x 5/16 inch, PHS
-50	210-0202-00			1						LUG, solder, SE #6
-51	386-0253-00			1						PLATE, metal, small
-52	210-0006-00			2						LOCKWASHER, internal, #6
-53	210-0407-00			2						NUT, hex., 6-32 x 1/4 inch
-54	384-0135-00			3						ROD, plastic, 5/16 x 15/16 inch - mounting hardware for each: (not included w/rod)
-55	213-0041-00			1						SCREW, thread cutting, 6-32 x 3/8 inch, THS
-56				1						RESISTOR - mounting hardware: (not included w/resistor)
-57	211-0507-00			1						SCREW, 6-32 x 5/16 inch, PHS
-58	210-0478-00			1						NUT, hex., 5/16 x 2 1/32 inch long
-59	211-0544-00			1						SCREW, 6-32 x 3/4 inch, THS
-60	441-0013-00			1						CHASSIS - mounting hardware: (not included w/chassis)
-61	211-0538-00			4						SCREW, 6-32 x 5/16 inch, 100° csk, FHS
-62	210-0457-00			4						NUT, keps, 6-32 x 5/16 inch



FIG. 4 TYPE 162 MECHANICAL PARTS (cont)

Fig. & Index No.	Tektronix Part No.	Serial/Model Eff	No. Disc	Q					Description	
				t	y	1	2	3		4
4-63	- - - - -			1						CAPACITOR
	- - - - -			-						mounting hardware: (not included w/capacitor)
-64	211-0538-00			2						SCREW, 6-32 x 5/16 inch, 100° csk, FHS
-65	210-0457-00			2						NUT, keps, 6-32 x 5/16 inch
-66	426-0019-00			1						FRAME
	- - - - -			-						frame includes:
-67	214-0024-00			1						FASTENER, spring
	- - - - -			-						mounting hardware: (not included w/frame)
-68	211-0538-00			2						SCREW, 6-32 x 5/16 inch, 100° csk, FHS
-69	210-0457-00			2						NUT, keps, 6-32 x 5/16 inch
-70	134-0006-00			1						PLUG, 8 pin
	- - - - -			-						mounting hardware: (not included w/plug)
-71	211-0507-00			2						SCREW, 6-32 x 5/16 inch, PHS
-72	386-0251-00			1						PLATE
-73	354-0002-00			1						RING, retaining
-74	210-0803-00			2						WASHER, flat, 0.150 ID x 3/8 inch OD
-75	210-0457-00			2						NUT, keps, 6-32 x 5/16 inch
-76	136-0013-00			1						SOCKET, tube, 8 pin
	- - - - -			-						mounting hardware: (not included w/socket)
-77	211-0507-00			2						SCREW, 6-32 x 5/16 inch, PHS
-78	210-0457-00			1						NUT, keps, 6-32 x 5/16 inch
-79	179-0085-00			1						CABLE HARNESS

FIG. 5 TYPE 163 MECHANICAL PARTS

Fig. & Index No.	Tektronix Part No.	Serial/Model Eff	No. Disc	Q † y	Description				
					1	2	3	4	5
5-1	333-0030-00	101	866	1	PANEL, front				
	333-0296-00	867		1	PANEL, front				
-2	366-0506-00	101	1123	1	KNOB, dial assembly—PULSE WIDTH MULTIPLIER				
	366-0524-00	1124	2889	1	KNOB, dial assembly—PULSE WIDTH MULTIPLIER				
	366-0525-00	2890	5549	1	KNOB, dial assembly—PULSE WIDTH MULTIPLIER				
	366-0525-01	5550		1	KNOB, dial assembly—PULSE WIDTH MULTIPLIER				
	- - - - -			-	knob includes:				
	213-0006-00	101	5549	1	SCREW, set, 8-32 x 3/16 inch, HSS				
	213-0004-00	5550		2	SCREW, set, 6-32 x 3/16 inch, HSS				
-3	- - - - -			2	RESISTOR, variable				
	- - - - -			-	mounting hardware for each: (not included w/resistor)				
-4	210-0207-00			1	LUG, solder, 3/8 ID x 5/8 inch OD, SE				
-5	210-0012-00			1	LOCKWASHER, internal, 3/8 ID x 1/2 inch OD				
-6	210-0840-00			1	WASHER, flat, 0.390 ID x 7/16 inch OD				
-7	210-0590-00			1	NUT, hex., 3/8-32 x 7/16 inch				
-8	366-0007-00	101	5549	1	KNOB, black—OUTPUT PULSE DELAY				
	366-0117-00	5550		1	KNOB, charcoal—OUTPUT PULSE DELAY				
	- - - - -			-	knob includes:				
	213-0006-00	101	5549	1	SCREW, set, 8-32 x 3/16 inch, HSS				
	213-0004-00	5550		1	SCREW, set, 6-32 x 3/16 inch, HSS				
-9	- - - - -			1	RESISTOR, variable				
	- - - - -			-	mounting hardware: (not included w/resistor)				
-10	210-0012-00			1	LOCKWASHER, internal, 3/8 ID x 1/2 inch OD				
-11	210-0840-00			1	WASHER, flat, 0.390 ID x 7/16 inch OD				
-12	210-0590-00			1	NUT, hex., 3/8-32 x 7/16 inch				
-13	366-0007-00	101	5549	1	KNOB, black—PULSE AMPLITUDE				
	366-0117-00	5550		1	KNOB, charcoal—PULSE AMPLITUDE				
	- - - - -			-	knob includes:				
	213-0006-00	101	5549	1	SCREW, set, 8-32 x 3/16 inch, HSS				
	213-0004-00	5550		1	SCREW, set, 6-32 x 3/16 inch, HSS				
-14	366-0007-00	101	5549	1	KNOB, black—PULSE WIDTH				
	366-0117-00	5550		1	KNOB, charcoal—PULSE WIDTH				
	- - - - -			-	knob includes:				
	213-0006-00	101	5549	1	SCREW, set, 8-32 x 3/16 inch, HSS				
	213-0004-00	5550		1	SCREW, set, 6-32 x 3/16 inch, HSS				
-15	262-0015-00	101	4379	1	SWITCH, wired—PULSE WIDTH				
	262-0621-00	4380		1	SWITCH, wired—PULSE WIDTH				
	- - - - -			-	switch includes:				
	260-0030-00			1	SWITCH, unwired				
	- - - - -			-	mounting hardware: (not included w/switch)				
-16	210-0012-00			1	LOCKWASHER, internal, 3/8 ID x 1/2 inch OD				
-17	210-0840-00			1	WASHER, flat, 0.390 ID x 7/16 inch OD				
-18	210-0590-00			1	NUT, hex., 3/8-32 x 7/16 inch				
-19	260-0014-00			1	SWITCH, toggle—TRIGGER SELECTOR				
	- - - - -			-	mounting hardware: (not included w/switch)				
-20	210-0414-00			1	NUT, hex., 15/32-32 x 7/16 inch				
-21	354-0055-00			1	RING, locking				
-22	210-0902-00			1	WASHER, flat, 0.370 ID x 21/32 inch OD				
-23	210-0473-00			1	NUT, 12 sided, 15/32-32 x 0.634 inch				

FIG. 5 TYPE 163 MECHANICAL PARTS (cont)

Fig. & Index No.	Tektronix Part No.	Serial/Model Eff	No. Disc	Q † y	1 2 3 4 5					Description
5-24	- - - - -			2						RESISTOR, variable
	- - - - -			-						mounting hardware for each: (not included w/resistor)
-25	210-0207-00			1						LUG, solder, 3/8 ID x 5/8 inch OD, SE
-26	210-0012-00			1						LOCKWASHER, internal, 3/8 ID x 1/2 inch OD
-27	210-0429-00			1						NUT, hex., 3/8-32 x 1/2 x 1 1/16 inches
-28	210-0013-00			1						LOCKWASHER, internal, 3/8 ID x 1 1/16 inch OD
-29	358-0010-00			1						BUSHING
-30	386-0296-00	101	866	1						PLATE, sub-panel, front
	386-0583-00	867		1						PLATE, sub-panel, front
-31	- - - - -			2						RESISTOR, variable
	- - - - -			-						mounting hardware for each: (not included w/resistor)
-32	210-0494-00			1						NUT, hex., 3/8-32 x 1 1/16 inch
-33	210-0013-00			1						LOCKWASHER, internal, 3/8 ID x 1/2 inch OD
-34	358-0010-00			1						BUSHING
-35	129-0020-00	X867		3						ASSEMBLY, binding post
	- - - - -			-						assembly includes:
	355-0503-00			1						STEM
	200-0072-00			1						CAP
	- - - - -			-						mounting hardware for each: (not included w/assembly)
-36	220-0410-00			1						NUT, keps, 10-32 x 3/8 inch
-37	129-0030-00	101	866	4						POST, binding
	129-0030-00	867	2078	3						POST, binding
	129-0036-00	2079	5549	3						POST, binding
	129-0063-00	5550		3						POST, binding
	- - - - -			-						mounting hardware for each: (not included w/post)
-38	358-0036-00	101	5549	1						BUSHING, plastic
	358-0169-00	5550		1						BUSHING, plastic
	210-0445-00	101	4419	2						NUT, hex., 10-32 x 3/8 inch
	210-0010-00	101	4419	1						LOCKWASHER, internal, #10
	210-0206-00	101	4419	1						LUG, solder, SE #10, long
-39	220-0410-00	4420		1						NUT, keps, 10-32 x 3/8 inch
-40	136-0008-00			1						SOCKET, tube, 7 pin, w/ground lugs
	- - - - -			-						mounting hardware: (not included w/socket)
	211-0033-00	101	2788	2						SCREW, sems, 4-40 x 5/16 inch, PHS
	210-0004-00	101	2788	2						LOCKWASHER, internal, #4
	210-0406-00	101	2788	2						NUT, hex., 4-40 x 3/16 inch
-41	213-0044-00	2789		2						SCREW, thread forming, 5-32 x 3/16 inch, PHS
-42	136-0015-00			5						SOCKET, tube, 9 pin, w/ground lugs
	- - - - -			-						mounting hardware for each: (not included w/socket)
	211-0033-00	101	2788	2						SCREW, sems, 4-40 x 5/16 inch, PHS
	210-0004-00	101	2788	2						LOCKWASHER, internal, #4
	210-0406-00	101	2788	2						NUT, hex., 4-40 x 3/16 inch
-43	213-0044-00	2789		2						SCREW, thread forming, 5-32 x 3/16 inch, PHS

FIG. 5 TYPE 163 MECHANICAL PARTS (cont)

Fig. & Index No.	Tektronix Part No.	Serial/Model Eff	No. Disc	Q					Description	
				†	y	1	2	3		4
5-44	348-0004-00			1						GROMMET, rubber, 3/8 inch diameter
-45	- - - - -			1						CAPACITOR
	- - - - -			-						mounting hardware: (not included w/capacitor)
-46	211-0534-00			2						SCREW, sems, 6-32 x 5/16 inch, PHS
-47	386-0253-00			1						PLATE, metal, small
-48	210-0202-00			1						LUG, solder, SE #6
-49	210-0006-00			1						LOCKWASHER, internal #6
-50	210-0407-00			2						NUT, hex., 6-32 x 1/4 inch
-51	- - - - -			1						RESISTOR
	- - - - -			-						mounting hardware: (not included w/resistor)
-52	211-0507-00			1						SCREW, 6-32 x 5/16 inch, PHS
-53	210-0478-00			1						NUT, hex., 5/16 x 2 1/32 inch long
-54	211-0544-00			1						SCREW, 6-32 x 3/4 inch, THS
-55	441-0014-00			1						CHASSIS
	- - - - -			-						mounting hardware: (not included w/chassis)
-56	211-0538-00			4						SCREW, 6-32 x 5/16 inch, 100° csk, FHS
-57	210-0437-00			4						NUT, keps, 6-32 x 5/16 inch
-58	426-0020-00			1						FRAME
	- - - - -			-						frame includes
-59	210-0024-00			1						FASTENER, spring
	- - - - -			-						mounting hardware: (not included w/frame)
-60	211-0538-00			4						SCREW, 6-32 x 5/16 inch, 100° csk, FHS
-61	210-0202-00			1						LUG, solder, SE #6
-62	210-0457-00			4						NUT, keps, 6-32 x 5/16 inch
-63	136-0013-00			1						SOCKET, tube, 8 pin
	- - - - -			-						mounting hardware: (not included w/socket)
-64	211-0507-00			2						SCREW, 6-32 x 5/16 inch, PHS
-65	210-0457-00			2						NUT, keps, 6-32 x 5/16 inch
-66	136-0006-00			1						PLUG, 8 pin
	- - - - -			-						mounting hardware: (not included w/plug)
-67	211-0507-00			2						SCREW, 6-32 x 3/8 inch, PHS
-68	386-0251-00			1						PLATE
-69	354-0002-00			1						RING, retaining
-70	210-0803-00			2						WASHER, flat, 0.150 ID x 3/8 inch OD
-71	210-0457-00			2						NUT, keps, 6-32 x 5/16 inch
-72	179-0128-00	101	909X	1						CABLE HARNESS

FIG. 5 TYPE 163 MECHANICAL PARTS (cont)

Fig. & Index No.	Tektronix Part No.	Serial/Model Eff	No. Disc	Q					Description	
				t	1	2	3	4		5
5-73	124-0015-00	101	2129	4						STRIP, ceramic, 3/4 inch h, w/11 notches
	124-0091-00	2130		4						STRIP, ceramic, 3/4 inch h, w/11 notches
	- - - - -			-						each strip includes:
	355-0046-00	X2130		2						STUD, plastic
	- - - - -			-						mounting hardware for each: (not included w/strip)
	210-0850-00	101	2129	2						WASHER, flat, 0.093 ID x 9/32 inch OD
	210-0002-00	101	2129	2						LOCKWASHER, external, #2
	210-0405-00	101	2129	2						NUT, hex., 2-56 x 3/16 inch
361-0007-00	2130		2						SPACER, plastic, 0.199 inch long	
-74	124-0013-00	101	2129	2						STRIP, ceramic, 3/4 inch h, w/7notches
	124-0089-00	2130		2						STRIP, ceramic, 3/4 inch h, w/7notches
	- - - - -			-						each strip includes:
	355-0046-00			2						STUD, plastic
	- - - - -			-						mounting hardware for each: (not included w/strip)
	210-0850-00	101	2129	2						WASHER, flat, 0.093 ID x 9/32 inch OD
	210-0002-00	101	2129	2						LOCKWASHER, external, #2
	210-0405-00	101	2129	2						NUT, hex., 2-56 x 3/16 inch
361-0007-00	2130		2						SPACER, plastic, 0.188 inch long	

FIG. 6 TYPE 360 FRONT

Fig. & Index No.	Tektronix Part No.	Serial/Model No. Eff	No. Disc	Q					Description	
				t	y	1	2	3		4
6-1	333-0133-00	101	514	1						PANEL, front
	333-0422-00	515		1						PANEL, front
-2	366-0033-00	101	4219	1						KNOB, black—FOCUS
	366-0148-00	4220		1						KNOB, charcoal—FOCUS
	- - - - -			-						knob includes:
	213-0004-00			1						SCREW, set, 6-32 x 3/16 inch, HSS
-3	- - - - -			2						RESISTOR, variable
	- - - - -			-						mounting hardware for each: (not included w/resistor)
-4	210-0012-00			1						LOCKWASHER, internal, 3/8 ID x 1/2 inch OD
-5	210-0840-00			1						WASHER, flat, 0.390 ID x 3/16 inch OD
-6	210-0413-00			1						NUT, hex., 3/8-32 x 1/2 inch
-7	366-0033-00	101	4219	1						KNOB, black—INTENSITY
	366-0148-00	4220		1						KNOB, charcoal—INTENSITY
	- - - - -			-						knob includes:
	213-0004-00			1						SCREW, set, 6-32 x 3/16 inch, HSS
-8	366-0033-00	101	4219	1						KNOB, black—SCALE ILLUM
	366-0148-00	4220		1						KNOB, charcoal—SCALE ILLUM
	- - - - -			-						knob includes:
	213-0004-00			1						SCREW, set, 6-32 x 3/16 inch, HSS
-9	- - - - -			1						RESISTOR, variable
	- - - - -			-						mounting hardware: (not included w/resistor)
-10	210-0207-00	101	477X	1						LUG, solder, 3/8 ID x 5/8 inch OD, SE
-11	210-0013-00			1						LOCKWASHER, internal, 3/8 ID x 1 1/16 inch OD
-12	210-0840-00			1						WASHER, flat, 0.390 ID x 3/16 inch OD
-13	210-0413-00			1						NUT, hex., 3/8-32 x 1/2 inch
-14	366-0031-00			1						KNOB, red—VARIABLE
	- - - - -			-						knob includes:
	213-0004-00			1						SCREW, set, 6-32 x 3/16 inch, HSS
-15	366-0029-00	101	4219	1						KNOB, black—VOLTS/DIV
	366-0142-00	4220		1						KNOB, charcoal—VOLTS/DIV
	- - - - -			-						knob includes:
	213-0004-00			1						SCREW, set, 6-32 x 3/16 inch, HSS
-16	262-0098-00			1						SWITCH, wired—VOLTS/DIV
	- - - - -			-						switch includes:
	260-0019-00			1						SWITCH, unwired
-17	- - - - -			1						RESISTOR, variable
	- - - - -			-						mounting hardware: (not included w/resistor)
-18	210-0413-00			2						NUT, hex., 3/8-32 x 1/2 inch
-19	210-0012-00			1						LOCKWASHER, internal, 3/8 ID x 1/2 inch OD
-20	376-0014-00			1						COUPLING, wire
-21	384-0077-00			1						ROD, extension shaft
	- - - - -			-						mounting hardware: (not included w/switch)
-22	210-0012-00			1						LOCKWASHER, internal, 3/8 ID x 1/2 inch OD
-23	210-0840-00			1						WASHER, flat, 0.390 ID x 3/16 inch OD
-24	210-0413-00			1						NUT, hex., 3/8-32 x 1/2 inch

FIG. 6 TYPE 360 FRONT (cont)

Fig. & Index No.	Tektronix Part No.	Serial/Model Eff	No. Disc	Q					Description	
				t y	1	2	3	4		5
6-25	366-0032-00			1						KNOB, red—POSITIONING (VERTICAL)
	213-0004-00			-						knob includes:
	213-0004-00			1						SCREW, set, 6-32 x 3/16 inch, HSS
-26	366-0030-00	101	4219	1						KNOB, black—POSITIONING (HORIZONTAL)
	366-0146-00	4220		1						KNOB, charcoal—POSITIONING (HORIZONTAL)
	213-0004-00			-						knob includes:
	213-0004-00			1						SCREW, set, 6-32 x 3/16 inch, HSS
-27				1						RESISTOR, variable
				-						mounting hardware: (not included w/resistor)
-28	210-0207-00			1						LUG, solder, 3/8 ID x 5/8 inch OD, SE
-29	210-0012-00			1						LOCKWASHER, internal, 3/8 ID x 1/2 inch OD
-30	210-0840-00			1						WASHER, flat, 0.390 ID x 7/16 inch OD
-31	210-0413-00			1						NUT, hex., 3/8-32 x 1/2 inch
-32	331-0027-00			1						GRATICULE, 8 cm vert x 10 cm horiz
-33	200-0073-00			1						COVER, graticule
				-						mounting hardware: (not included w/cover)
-34	210-0434-00			4						NUT, knurled, 10-32 x 0.515 x 3/8 inch
-35	210-0844-00			4						WASHER, rubber, 7/32 ID x 3/8 inch OD
-36	131-0038-00			1						CONNECTOR, coaxial, 1 contact, UHF
				-						mounting hardware: (not included w/connector)
-37	211-0038-00			2						SCREW, 4-40 x 5/16 inch, 100° csk, FHS
-38	210-0004-00			2						LOCKWASHER, internal, #4
-39	210-0406-00			2						NUT, hex., 4-40 x 3/16 inch
-40				3						RESISTOR, variable
				-						mounting hardware for each: (not included w/resistor)
-41	210-0046-00			1						LOCKWASHER, internal, 1/4 ID x 0.400 inch OD
-42	210-0583-00			1						NUT, hex., 1/4-32 x 5/16 inch
-43	406-0162-00			1						BRACKET, resistor mounting
-44	129-0030-00	101	1409	2						POST, binding, hex., cap
	129-0036-00	1410	4219	2						POST, binding, fluted cap
	129-0063-00	4220		1						POST, binding, fluted cap
				-						mounting hardware for each: (not included w/post)
-45	358-0036-00	101	4219	1						BUSHING, plastic
	358-0169-00	4220		1						BUSHING, plastic
	210-0445-00	101	3339	2						NUT, hex., 10-32 x 3/8 inch
-46	220-0410-00	3340		1						NUT, keps, 10-32 x 3/8 inch
	210-0010-00	101	3339X	1						LOCKWASHER, internal, #10
	210-0206-00	101	3339X	1						LUG, solder, SE #10 long

FIG. 6 TYPE 360 FRONT (cont)

Fig. & Index No.	Tektronix Part No.	Serial/Model Eff	No. Disc	Q					Description	
				t	y	1	2	3		4
6-47	260-0134-00			1						SWITCH, toggle—AC-DC
	260-0014-00			1						SWITCH, toggle—AC-DC
	- - - - -			-						mounting hardware: (not included w/switch)
-48	354-0055-00			1						RING, locking
-49	210-0902-00			2						WASHER, flat, 0.470 ID x 2 <sup>1</sup> / <sub>32</sub> inch OD
-50	210-0473-00			1						NUT, 12 sided, 1 <sup>5</sup> / <sub>32</sub> -32 x 0.634 inch
	129-0051-00	X515		1						ASSEMBLY, binding post
	- - - - -			-						assembly includes:
-51	200-0182-00			1						CAP
-52	355-0507-00			1						STEM
	- - - - -			-						mounting hardware: (not included w/assembly)
-53	210-0046-00			1						LOCKWASHER, internal, 1/4 ID x 0.400 inch OD
-54	210-0455-00			1						NUT, hex., 1/4-28 x 3/8 x 3/32 inch
-55	124-0050-00	101	3579	1						STRIP, plastic
	124-0172-00	3580		1						STRIP, rubber
-56	337-0101-00			1						SHIELD, CRT
	- - - - -			-						mounting hardware: (not included w/shield)
-57	212-0509-00			4						SCREW, 10-32 x 5/8 inch, PHS
-58	343-0029-00			1						CLAMP, CRT
	- - - - -			-						mounting hardware: (not included w/clamp)
-59	211-0507-00			4						SCREW, 6-32 x 1/4 inch, PHS
-60	210-0803-00			4						WASHER, flat, 0.150 ID x 3/8 inch OD
-61	210-0457-00			4						NUT, keps, 6-32 x 5/16 inch
-62	212-0557-00			1						SCREW, 10-32 x 5/8 inch, 100° csk, FHS
-63	210-0501-00			1						NUT, square, 6-32 x 1/4 inch
-64	136-0023-00	101	2576	1						SOCKET, STM12
	136-0081-00	2577		1						SOCKET, CRT, 12 pin
-65	136-0035-00			1						SOCKET, graticule light, w/ground lugs
	- - - - -			-						mounting hardware for each: (not included w/socket)
-66	211-0534-00			2						SCREW, sems, 6-32 x 5/16 inch, PHS
-67	210-0803-00			2						WASHER, flat, 0.150 ID x 3/8 inch OD
-68	210-0457-00			2						NUT, keps, 6-32 x 5/16 inch
-69	337-0115-00	101	1000	1						SHIELD, 2 <sup>3</sup> / <sub>8</sub> x 2 <sup>3</sup> / <sub>8</sub> x 2 <sup>9</sup> / <sub>16</sub> inches
	337-0252-00	1001		1						SHIELD, 2 <sup>3</sup> / <sub>8</sub> x 2 <sup>3</sup> / <sub>4</sub> x 2 <sup>1</sup> / <sub>8</sub> inches
-70	348-0003-00			1						GROMMET, rubber, 5/16 inch
-71	386-0397-00			1						PLATE, front sub-panel



FIG. 7 TYPE 360 CHASSIS & REAR

Fig. & Index No.	Tektronix Part No.	Serial/Model Eff	No. Disc	Q t y	Description					
					1	2	3	4	5	
7-1	260-0014-00	X132		1						SWITCH, toggle—(SAWTOOTH POLARITY)
	- - - - -			-						mounting hardware: (not included w/switch)
-2	210-0414-00			1						NUT, hex., $1\frac{5}{32}$ -32 x $\frac{9}{16}$ inch
-3	354-0055-00			1						RING, locking
-4	210-0473-00			1						NUT, 12 sided, $1\frac{5}{32}$ -32 x 0.634 inch
-5	136-0032-00	101	1000	6						SOCKET, tube, 7 pin
	136-0008-00	1001		6						SOCKET, tube, 7 pin, w/ground lugs
	- - - - -			-						mounting hardware for each: (not included w/socket)
-6	213-0044-00			2						SCREW, thread forming, 5-32 x $\frac{3}{16}$ inch, PHS
-7	136-0013-00			1						SOCKET, tube, 8 pin
	- - - - -			-						mounting hardware: (not included w/socket)
-8	211-0534-00			2						SCREW, sems, 6-32 x $\frac{5}{16}$ inch, PHS
-9	210-0006-00			2						LOCKWASHER, internal, #6
-10	210-0202-00			1						LUG, solder, SE #6
-11	210-0407-00			2						NUT, hex., 6-32 x $\frac{1}{4}$ inch
-12	343-0006-00			1						CLAMP, cable, plastic, $\frac{1}{2}$ inch
	- - - - -			-						mounting hardware: (not included w/clamp)
-13	211-0510-00			1						SCREW, 6-32 x $\frac{3}{8}$ inch, PHS
-14	210-0803-00			1						WASHER, flat, 0.150 ID x $\frac{3}{8}$ inch OD
-15	- - - - -			1						TRANSFORMER
	- - - - -			-						mounting hardware: (not included w/transformer)
-16	346-0001-00			1						STRAP, mounting
-17	210-0004-00			2						LOCKWASHER, internal, #4
-18	210-0406-00			2						NUT, hex., 4-40 x $\frac{3}{16}$ inch
-19	348-0002-00			2						GROMMET, rubber, $\frac{1}{4}$ inch
-20	348-0012-00			1						GROMMET, rubber, $\frac{5}{8}$ inch
-21	348-0005-00			2						GROMMET, rubber, $\frac{1}{2}$ inch
-22	348-0004-00			3						GROMMET, rubber, $\frac{3}{8}$ inch
-23	348-0003-00			1						GROMMET, rubber, $\frac{5}{16}$ inch
-24	- - - - -			1						TRANSFORMER
	- - - - -			-						mounting hardware: (not included w/transformer)
-25	346-0006-00			1						STRAP, mounting
-26	210-0004-00			2						LOCKWASHER, internal, #4
-27	210-0406-00			2						NUT, hex., 4-40 x $\frac{3}{16}$ inch
-28	381-0050-00			1						BAR, frame
	- - - - -			-						mounting hardware: (not included w/bar)
	211-0538-00			1						SCREW, 6-32 x $\frac{5}{16}$ inch, 100° csk, FHS (not shown)
-29	211-0507-00			1						SCREW, 6-32 x $\frac{5}{16}$ inch, PHS

FIG. 7 TYPE 360 CHASSIS & REAR (cont)

Fig. & Index No.	Tektronix Part No.	Serial/Model No. Eff	No. Disc	Q † y	Description				
					1	2	3	4	5
7-30	381-0051-00			1	BAR, frame				
	- - - - -			-	mounting hardware: (not included w/bar)				
	211-0538-00			1	SCREW, 6-32 x 5/16 inch, 100° csk, FHS (not shown)				
	211-0507-00			1	SCREW, 6-32 x 5/16 inch, PHS (not shown)				
-31	381-0049-00			2	BAR, frame				
	- - - - -			-	mounting hardware: (not included w/bar)				
	211-0538-00			1	SCREW, 6-32 x 5/16 inch, 100° csk, FHS (not shown)				
-32	211-0507-00			1	SCREW, 6-32 x 5/16 inch, PHS				
-33	381-0048-00			1	BAR, support				
	- - - - -			-	mounting hardware: (not included w/bar)				
	211-0538-00			1	SCREW, 6-32 x 5/16 inch, 100° csk, FHS (not shown)				
-34	211-0507-00			3	SCREW, 6-32 x 5/16 inch, PHS				
-35	385-0113-00	X1001		3	ROD, plastic, 5/16 x 1 1/8 inches				
	- - - - -			-	mounting hardware for each: (not included w/rod)				
-36	211-0507-00			1	SCREW, 6-32 x 5/16 inch, PHS				
-37	- - - - -			1	CAPACITOR				
	- - - - -			-	mounting hardware: (not included w/capacitor)				
-38	211-0534-00			2	SCREW, sems, 6-32 x 5/16 inch, PHS				
-39	386-0253-00			1	PLATE, metal, small				
-40	210-0006-00			2	LOCKWASHER, internal, #6				
-41	210-0407-00			2	NUT, hex., 6-32 x 1/4 inch				
-42	136-0034-00	101	1000	2	SOCKET, tube, 9 pin				
	136-0015-00	1001		2	SOCKET, tube, 9 pin, w/ground lugs				
	- - - - -			-	mounting hardware for each: (not included w/socket)				
-43	213-0044-00			1	SCREW, thread forming, 5-32 x 3/16 inch, PHS				
-44	134-0006-00			1	PLUG, 8 pin				
	- - - - -			-	mounting hardware: (not included w/plug)				
-45	354-0002-00			1	RING, socket, retaining				
-46	386-0251-00			1	PLATE				
-47	211-0507-00			2	SCREW, 6-32 x 5/16 inch, PHS				
-48	210-0803-00			2	WASHER, flat, 0.150 ID x 3/8 inch OD				
-49	210-0006-00			2	LOCKWASHER, internal, #6				
-50	210-0407-00			2	NUT, hex., 6-32 x 1/4 inch				

FIG. 7 TYPE 360 CHASSIS & REAR (cont)

Fig. & Index No.	Tektronix Part No.	Serial/Model Eff	No. Disc	Q † y	Description				
					1	2	3	4	5
7-51	406-0163-00	101	1000	1	BRACKET, capacitor mounting				
	406-0385-00	1001		1	BRACKET, capacitor mounting				
	- - - - -			-	mounting hardware (not included w/bracket)				
-52	211-0507-00			4	SCREW, 6-32 x 5/16 inch, PHS				
-53	210-0803-00			2	WASHER, flat, 0.150 ID x 3/8 inch OD				
-54	- - - - -			1	RESISTOR, variable				
	- - - - -			-	mounting hardware: (not included w/resistor)				
-55	210-0840-00			1	WASHER, flat, 0.390 ID x 9/16 inch OD				
-56	210-0413-00			1	NUT, hex., 3/8-32 x 1/2 inch				
-57	210-0201-00			1	LUG, solder, SE #4				
	- - - - -			-	mounting hardware: (not included w/lug)				
-58	213-0044-00			1	SCREW, thread forming, 5-32 x 3/16 inch, PHS				
-59	- - - - -			1	RESISTOR, variable				
	- - - - -			-	mounting hardware: (not included w/resistor)				
-60	210-0207-00			1	LUG, solder, 3/8 ID x 5/8 inch OD, SE				
-61	210-0012-00			1	LOCKWASHER, internal, 3/8 ID x 1/2 inch OD				
-62	210-0840-00			1	WASHER, flat, 0.390 ID x 9/16 inch OD				
-63	210-0413-00			1	NUT, hex., 3/8-32 x 1/2 inch				
-64	- - - - -			1	RESISTOR				
	- - - - -			-	mounting hardware: (not included w/resistor)				
-65	211-0544-00			1	SCREW, 6-32 x 3/4 inch, THS				
-66	210-0478-00			1	NUT, hex., 6-32 x 5/16 x 2 1/32 inch h				
-67	211-0507-00			1	SCREW, 6-32 x 5/16 inch, PHS				
-68	387-0546-00			1	PLATE, frame				
	- - - - -			-	plate includes:				
-69	214-0029-00			1	FASTENER, spring				
-70	337-0112-00	101	1000	1	SHIELD, high voltage				
	337-0253-00	1001		1	SHIELD, high voltage				
	- - - - -			-	mounting hardware: (not included w/shield)				
-71	211-0507-00			1	SCREW, 6-32 x 5/16 inch, PHS				
-72	210-0803-00			1	WASHER, flat, 0.150 ID x 3/8 inch OD				
-73	337-0113-00	101	1000	1	SHIELD, high voltage				
	337-0254-00	1001		1	SHIELD, high voltage				
	- - - - -			-	mounting hardware: (not included w/shield)				
-74	211-0507-00			1	SCREW, 6-32 x 5/16 inch, PHS				
-75	210-0803-00			1	WASHER, flat, 0.150 ID x 3/8 inch OD				

FIG. 7 TYPE 360 CHASSIS & REAR (cont)

Fig. & Index No.	Tektronix Part No.	Serial/Model No. Eff	No. Disc	Q † y	Description				
					1	2	3	4	5
7-76	386-0441-00	101	1000	1	PLATE, circuit board				
	441-0207-00	1001		1	CHASSIS				
	- - - - -			-	mounting hardware: (not included w/chassis)				
	166-0035-00	101	1000	1	TUBE, spacer, 0.180 ID x 1/4 OD x 1/2 inch long				
	166-0030-00	101	1000	1	TUBE, spacer, 0.180 ID x 1/4 OD x 3/16 inch long				
	211-0514-00	101	1000	1	SCREW, 6-32 x 3/4 inch, PHS				
	211-0510-00	101	1000	1	SCREW, 6-32 x 3/8 inch, PHS				
-77	166-0039-00	1001		1	TUBE, spacer, 0.180 ID x 1/4 OD x 1 inch long				
-78	210-0202-00	1001		3	LUG, solder, SE #6				
-79	211-0529-00	1001		3	SCREW, 6-32 x 1 1/4 inches, PHS				
-80	179-0095-00	101	1000	1	CABLE HARNESS, main				
	179-0244-00	1001		1	CABLE HARNESS, main				
	179-0096-00	101	1000X	1	CABLE HARNESS, sub-panel				
-81	179-0097-00	101	1000	1	CABLE HARNESS, focus & intensity				
	179-0247-00	1001		1	CABLE HARNESS, focus & intensity				
-82	124-0013-00	101	1405	1	STRIP, ceramic, 3/4 inch h, w/7 notches				
	124-0089-00	1406		1	STRIP, ceramic, 3/4 inch h, w/7 notches				
	- - - - -			-	strip includes:				
	355-0046-00	X1406		2	STUD, plastic				
	- - - - -			-	mounting hardware: (not included w/strip)				
	210-0850-00	101	1405	2	WASHER, flat, 0.093 ID x 9/32 inch OD				
	210-0002-00	101	1405	2	LOCKWASHER, external, #2				
	210-0405-00	101	1405	2	NUT, hex., 2-56 x 3/16 inch				
	361-0007-00	1406		2	SPACER, plastic, 0.188 inch long				
-83	124-0014-00	101	1405	2	STRIP, ceramic, 3/4 inch h, w/7 notches				
	124-0089-00	1406		2	STRIP, ceramic, 3/4 inch h, w/7 notches				
	- - - - -			-	each strip includes:				
	355-0046-00	X1406		2	STUD, plastic				
	- - - - -			-	mounting hardware for each: (not included w/strip)				
	210-0850-00	101	1405	2	WASHER, flat, 0.093 ID x 9/32 inch OD				
	210-0002-00	101	1405	2	LOCKWASHER, external, #2				
	210-0405-00	101	1405	2	NUT, hex., 2-56 x 3/16 inch				
	361-0009-00	1406		2	SPACER, plastic, 0.406 inch long				
-84	124-0066-00	101	1405	8	STRIP, ceramic, 3/4 inch h, w/9 notches				
	124-0090-00	1406		8	STRIP, ceramic, 3/4 inch h, w/9 notches				
	- - - - -			-	each strip includes:				
	355-0046-00	X1406		2	STUD, plastic				
	- - - - -			-	mounting hardware for each: (not included w/strip)				
	210-0850-00	101	1405	2	WASHER, flat, 0.093 ID x 9/32 inch OD				
	210-0002-00	101	1405	2	LOCKWASHER, external, #2				
	210-0405-00	101	1405	2	NUT, hex., 2-56 x 3/16 inch				
	361-0009-00	1406		2	SPACER, plastic, 0.406 inch long				

FIG. 7 TYPE 360 CHASSIS & REAR (cont)

Fig. & Index No.	Tektronix Part No.	Serial/Model Eff	No. Disc	Q † y	1 2 3 4 5					Description	
					1	2	3	4	5		
7-85	124-0016-00	101	1405	3						STRIP, ceramic, 3/4 inch h, w/11 notches	
	124-0091-00	1406		3						STRIP, ceramic, 3/4 inch h, w/11 notches	
	- - - - -				-						each strip includes:
	355-0046-00	X1406			2						STUD, plastic
	- - - - -				-						mounting hardware for each: (not included w/strip)
	210-0850-00	101		1405	2						WASHER, flat, 0.093 ID x 9/32 inch OD
	210-0002-00	101		1405	2						LOCKWASHER, external, #2
	210-0405-00	101		1405	2						NUT, hex., 2-56 x 3/16 inch
	361-0009-00	1406		2						SPACER, plastic, 0.406 inch long	
-86	437-0032-00	101	1949	1						CABINET, blue wrinkle	
	437-0054-00	1950		1							CABINET, blue vinyl
	- - - - -			-						cabinet includes:	
-87	355-0028-00			1						STUD	
-88	384-0517-00			1						ROD, pin	
	214-0118-00			2						CLIP, spring (not shown)	

FIG. 8 TYPE 126 MECHANICAL PARTS & CABINET

Fig. & Index No.	Tektronix Part No.	Serial/Model Eff	No. Disc	Q					Description
				†	1	2	3	4	
8-1	387-0560-00			1					PLATE, top
	- - - - -			-					mounting hardware (not included w/plate)
-2	211-0541-00			3					SCREW, 6-32 x 1/4 inch, 100° csk, FHS
-3	211-0507-00			2					SCREW, 6-32 x 5/16 inch, PHS
-4	210-0903-00			2					WASHER, flat, 0.150 ID x 3/8 inch OD
-5	348-0004-00			1					GROMMET, rubber, 3/8 inch
-6	175-0020-00			FT					CABLE, 8 conductor (1.958 inches)
-7	348-0012-00			1					GROMMET, rubber, 5/8 inch
-8	200-0098-00			1					CAP, cable
-9	136-0012-00			1					SOCKET, 8 pin
-10	131-0010-00	101	240	1					CONNECTOR, motor base, 2 contact
	131-0102-00	241		1					CONNECTOR, motor base, 3 contact
	- - - - -			-					connector includes:
-11	129-0041-00	X241		1					POST, ground
-12	200-0185-00	X241		1					COVER
	210-0003-00	X241		2					LOCKWASHER, external, #4 (not shown)
	210-0551-00	X241		2					NUT, hex., 4-40 x 1/4 inch (not shown)
-13	211-0015-00	X241		1					SCREW, 4-40 x 1/2 inch, RHS
-14	214-0078-00	X241		2					PIN, connecting
-15	377-0041-00	X241		1					INSERT, black plastic
-16	386-0933-00	X241		1					PLATE
	- - - - -			-					mounting hardware: (not included w/connector)
-17	211-0507-00			2					SCREW, 6-32 x 5/16 inch, PHS
-18	210-0006-00			2					LOCKWASHER, internal, #6
-19	210-0407-00			2					NUT, hex., 6-32 x 1/4 inch
-20	- - - - -			1					CAPACITOR
	- - - - -			-					mounting hardware: (not included w/capacitor)
-21	211-0514-00			1					SCREW, 6-32 x 3/4 inch, PHS
	211-0516-00			1					SCREW, 6-32 x 7/8 inch (not shown)
-22	210-0005-00			2					LOCKWASHER, external, #6
-23	166-0035-00			2					TUBE, spacer
-24	386-0253-00			1					PLATE, metal, small
-25	210-0803-00			1					WASHER, flat, 0.150 ID x 3/8 inch OD
-26	210-0006-00			1					LOCKWASHER, internal, #6
-27	210-0407-00			2					NUT, hex., 6-32 x 1/4 inch
-28	343-0003-00			1					CLAMP, cable, plastic, 1/4 inch
-29	- - - - -			1					RESISTOR, variable
	- - - - -			-					mounting hardware: (not included w/resistor)
	210-0840-00			1					WASHER, flat, 0.390 ID x 3/16 inch OD
	210-0413-00			1					NUT, hex., 3/8-32 x 1/2 inch

FIG. 8 TYPE 126 MECHANICAL PARTS & CABINET (cont)

Fig. & Index No.	Tektronix Part No.	Serial/Model Eff	No. Disc	Q					Description
				t y	1	2	3	4	
8-30	136-0008-00			2					SOCKET, tube, 7 pin, w/ground lugs
	- - - - -			-					mounting hardware for each: (not included w/socket)
-31	211-0033-00			2					SCREW, sems, 4-40 x 5/16 inch, PHS
-32	210-0004-00			2					LOCKWASHER, internal, #4
-33	210-0406-00			2					NUT, hex., 4-40 x 3/16 inch
-34	348-0002-00			1					GROMMET, rubber, 1/4 inch
-35	- - - - -			1					CAPACITOR
	- - - - -			-					mounting hardware: (not included w/capacitor)
-36	211-0534-00			2					SCREW, sems, 6-32 x 5/16 inch, PHS
-37	386-0252-00			1					PLATE, fiber, small
-38	210-0006-00			2					LOCKWASHER, internal, #6
-39	210-0407-00			2					NUT, hex., 6-32 x 1/4 inch
-40	200-0256-00			1					COVER, capacitor, plastic, 1 diameter x 2 1/32 inches
-41	- - - - -			1					TRANSFORMER
	- - - - -			-					transformer includes:
-42	212-0030-00			4					SCREW, 8-32 x 4 inches, HHS
-43	210-0008-00			4					LOCKWASHER, internal, #8
-44	210-0409-00			4					NUT, hex., 8-32 x 5/16 inch
-45	136-0015-00			5					SOCKET, tube, 9 pin, w/ground lugs
	- - - - -			-					mounting hardware for each: (not included w/socket)
-46	211-0033-00			2					SCREW, sems, 4-40 x 5/16 inch, PHS
-47	210-0004-00			2					LOCKWASHER, internal, #4
-48	210-0406-00			2					NUT, hex., 4-40 x 3/16 inch
-49	441-0125-00			1					CHASSIS, power
-50	260-0134-00			1					SWITCH, toggle—POWER ON
	- - - - -			-					switch includes:
	210-0414-00			1					NUT, hex., 15/32-32 x 9/16 inch (not shown)
	- - - - -			-					mounting hardware: (not included w/switch)
-51	210-0902-00			1					WASHER, flat, 0.470 ID x 2 1/32 inch OD
-52	210-0473-00			1					NUT, 15/32-32 x 5/64 inch, 12 sided
-53	136-0025-00			1					SOCKET, light, w/hardware
-54	378-0518-00			1					JEWEL, light, pilot
-55	333-0224-00			1					PANEL, front
	352-0002-00			1					ASSEMBLY, fuse holder
	- - - - -			-					assembly includes:
-56	352-0010-00			1					HOLDER, fuse
-57	200-0015-00			1					CAP
-58	210-0873-00			1					WASHER, rubber, 1/2 ID x 1 1/16 inch OD
-59	- - - - -			1					NUT
-60	387-0559-00			1					PLATE, bottom
	- - - - -			-					mounting hardware: (not included w/plate)
-61	211-0541-00			5					SCREW, 6-32 x 1/4 inch, 100° csk, FHS
-62	211-0507-00			5					SCREW, 6-32 x 5/16 inch, PHS
-63	210-0803-00			2					WASHER, flat, 0.150 ID x 3/8 inch OD

FIG. 8 TYPE 126 MECHANICAL PARTS & CABINET (cont)

Fig. & Index No.	Tektronix Part No.	Serial/Model Eff	No. Disc	Q					Description		
				†	Y	1	2	3		4	5
8-64	179-0111-00									1	CABLE HARNESS
-65	124-0015-00	101	220							4	STRIP, ceramic, 3/4 inch h, w/11 notches
	124-0091-00	221								4	STRIP, ceramic, 3/4 inch h, w/11 notches
	- - - - -									-	each strip includes:
	355-0046-00	X221								2	STUD, plastic
	- - - - -									-	mounting hardware for each: (not included w/strip)
	210-0405-00	101	220							4	NUT, hex., 2-56 x 3/16 inch
	210-0850-00	101	220							2	WASHER, flat, 0.093 ID x 9/32 inch OD
	210-0002-00	101	220							2	LOCKWASHER, external, #2
	361-0007-00	221								2	SPACER, plastic, 0.188 inch long
-66	437-0037-00	101	279							1	CABINET
	437-0051-00	280								1	CABINET
	- - - - -									-	cabinet includes:
-67	367-0005-00									1	HANDLE, leather, w/hardware
-68	348-0001-00									4	FOOT, rubber
	- - - - -									-	mounting hardware for each: (not included w/foot)
-69	211-0507-00									1	SCREW, 6-32 x 5/16 inch, PHS
	210-0407-00									1	NUT, hex., 6-32 x 1/4 inch (not shown)
-70	334-0649-00									1	TAG, voltage rating
	- - - - -									-	mounting hardware: (not included w/tag)
-71	213-0088-00									2	SCREW, thread forming, 4-40 x 1/4 inch, PHS



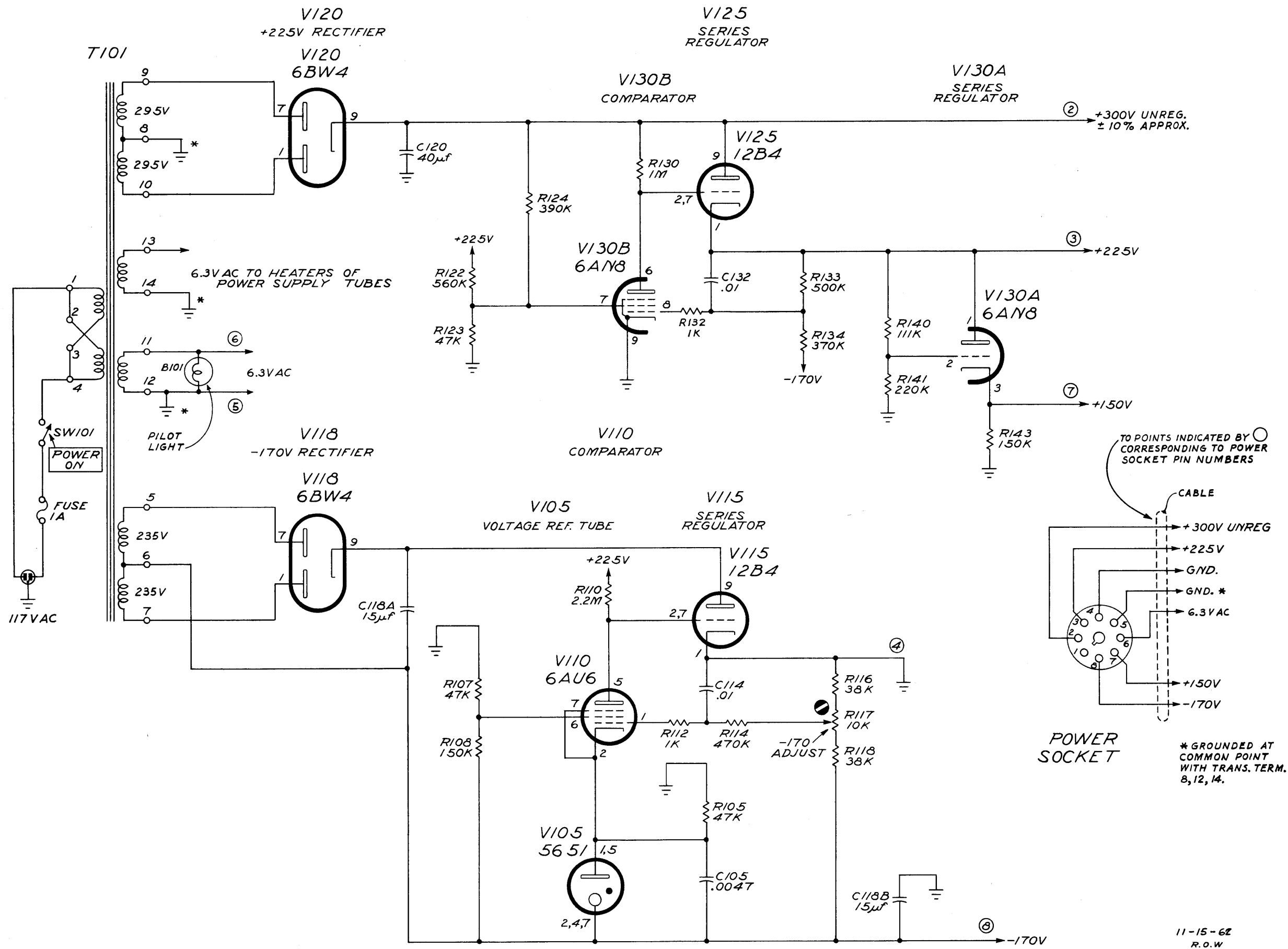

TYPE 126

AA<sub>1</sub>

POWER SUPPLY

11-15-62  
R.O.W.

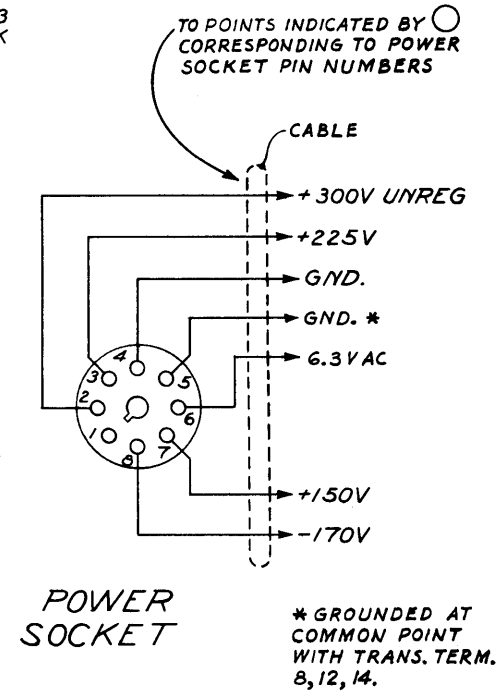

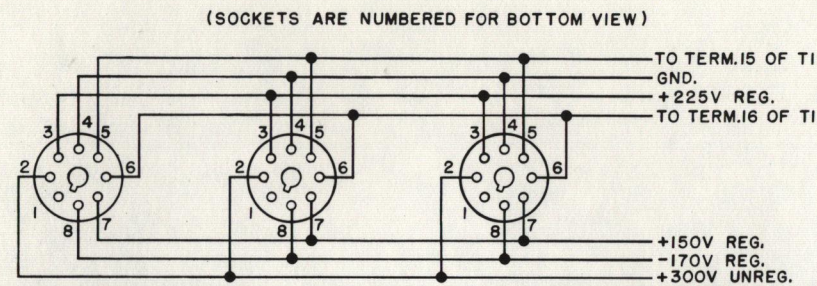
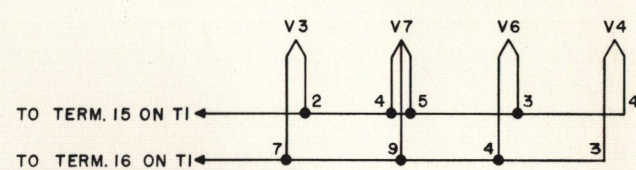
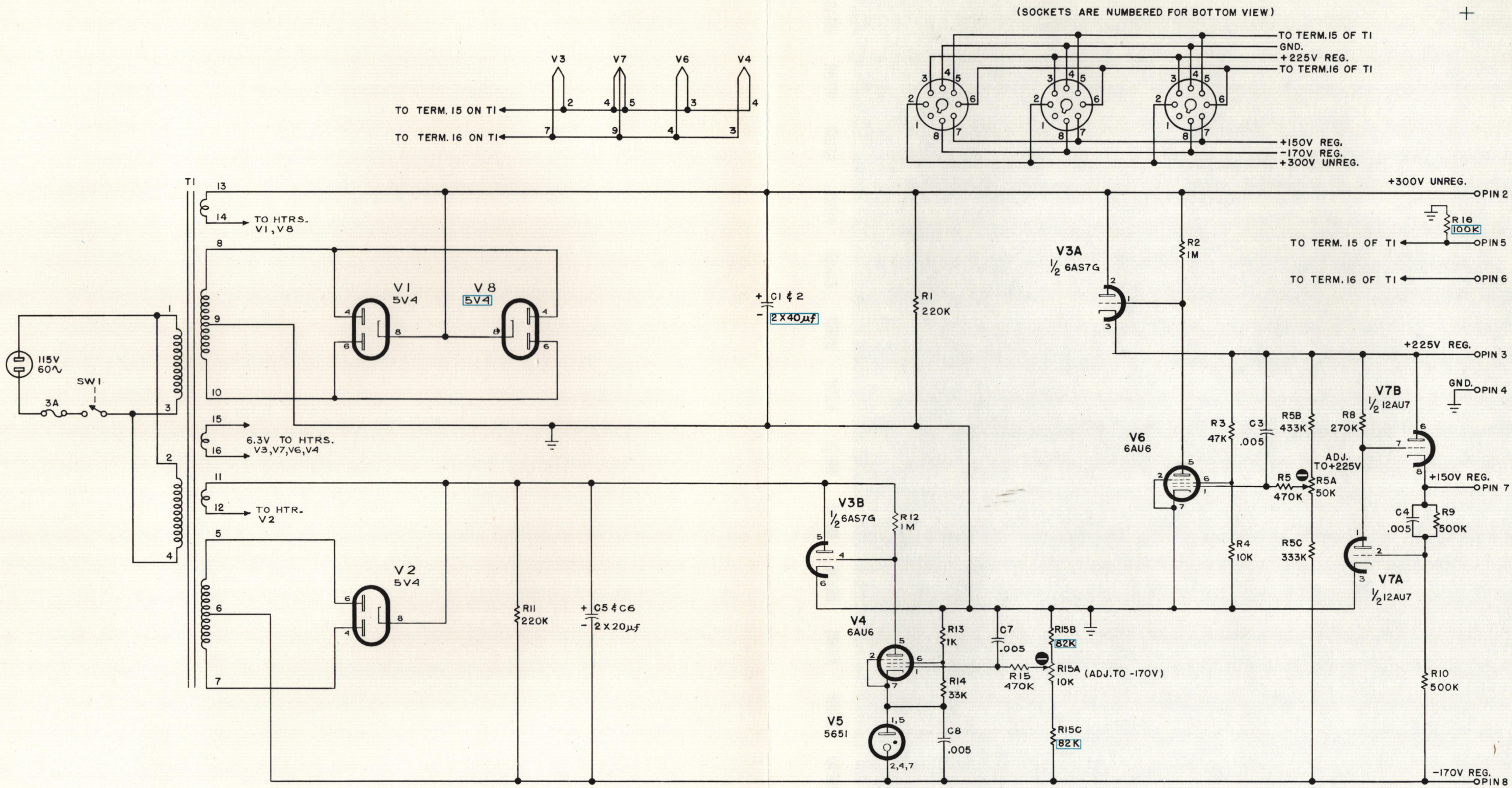

SEE PARTS LIST FOR EARLIER VALUES AND SERIAL NUMBER RANGES OF PARTS MARKED WITH BLUE OUTLINE.

AA<sub>2</sub>

TYPE 160 POWER SUPPLY  
S/N 101-619

L.A.P.  
664

POWER SUPPLY

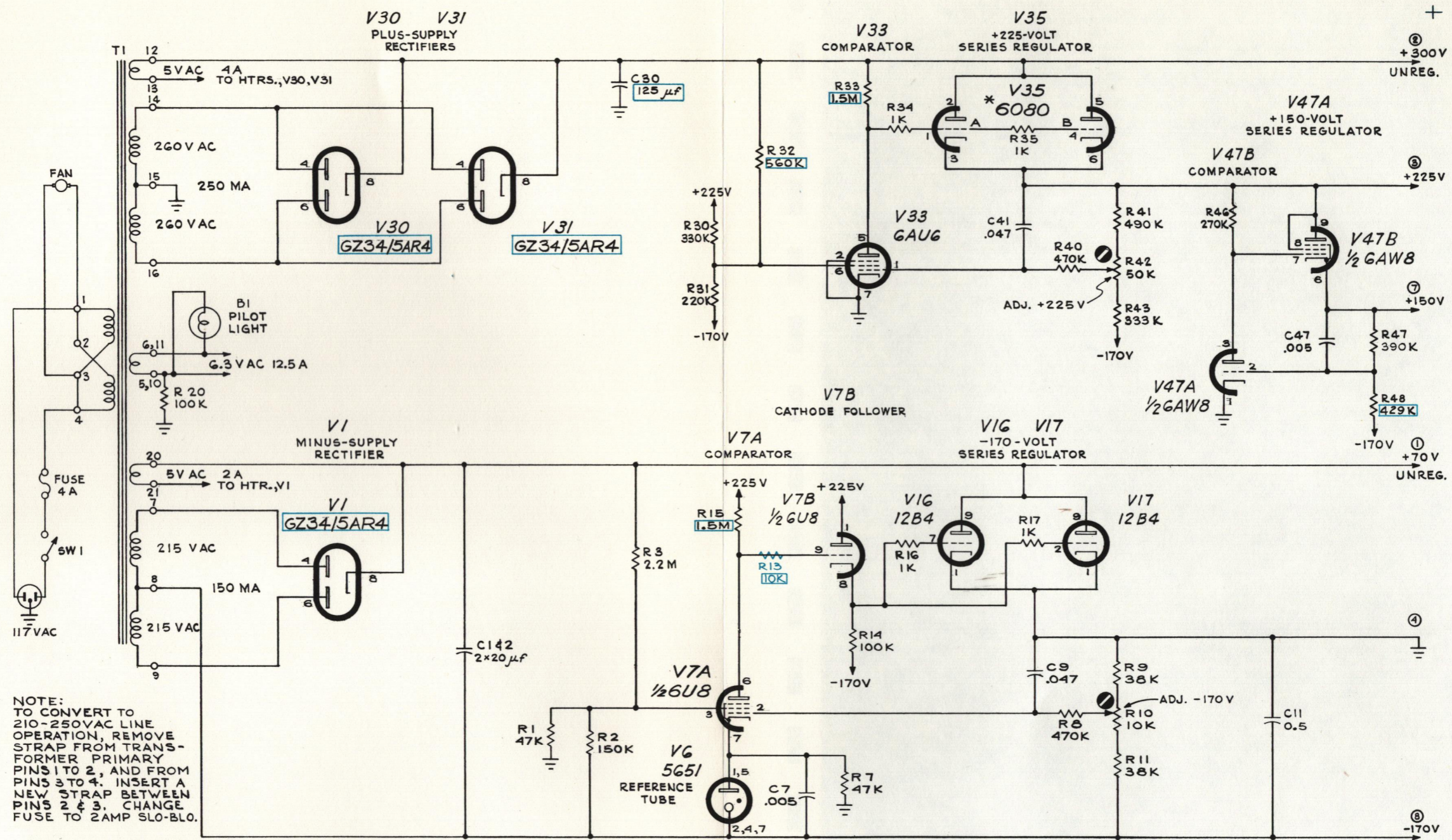

NOTE:  
 TO CONVERT TO  
 210-250VAC LINE  
 OPERATION, REMOVE  
 STRAP FROM TRANS-  
 FORMER PRIMARY  
 PINS 1 TO 2, AND FROM  
 PINS 3 TO 4. INSERT A  
 NEW STRAP BETWEEN  
 PINS 2 & 3. CHANGE  
 FUSE TO 2AMP SLO-BLO.

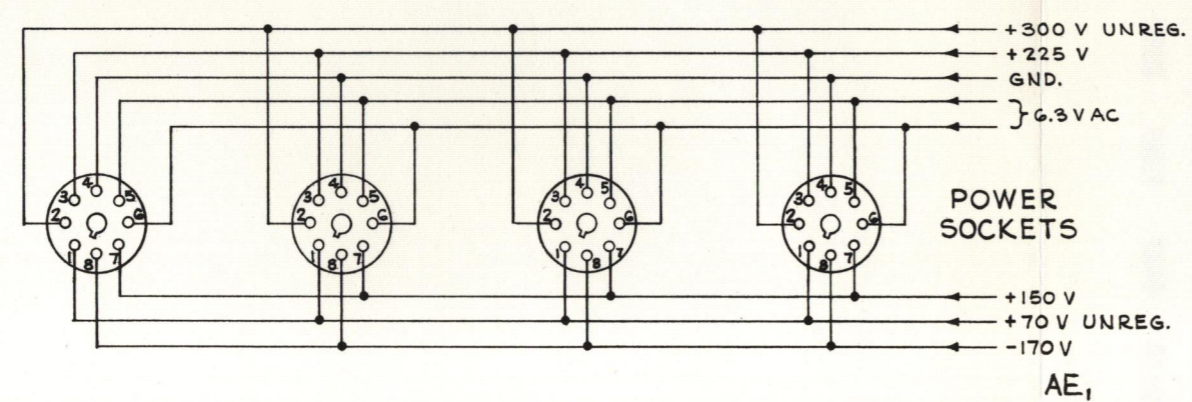

SEE PARTS LIST FOR EARLIER  
 VALUES AND SERIAL NUMBER  
 RANGES OF PARTS MARKED  
 WITH BLUE OUTLINE.

\* 6AS7 MAY  
 BE USED

566  
 RBH

TYPE 160A POWER SUPPLY  
 S/N 620 UP

POWER SUPPLY

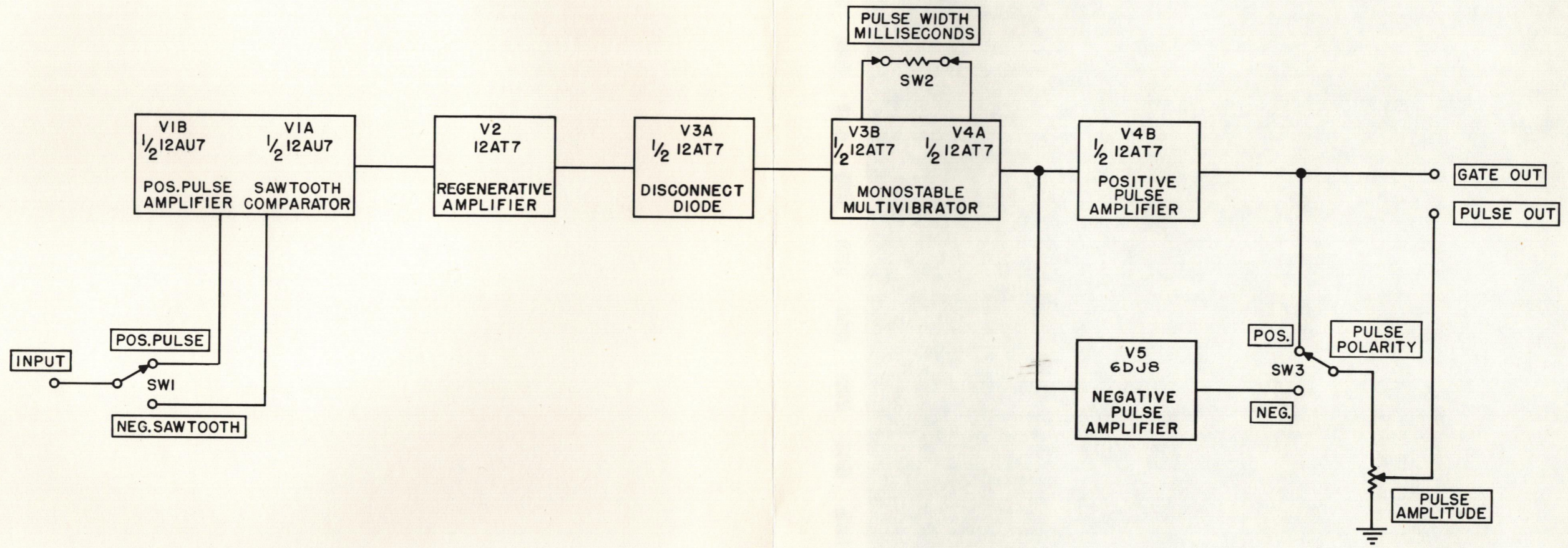

TYPE 161 PULSE GENERATOR

AA,

L.A.P.  
11-11-62

BLOCK DIAGRAM

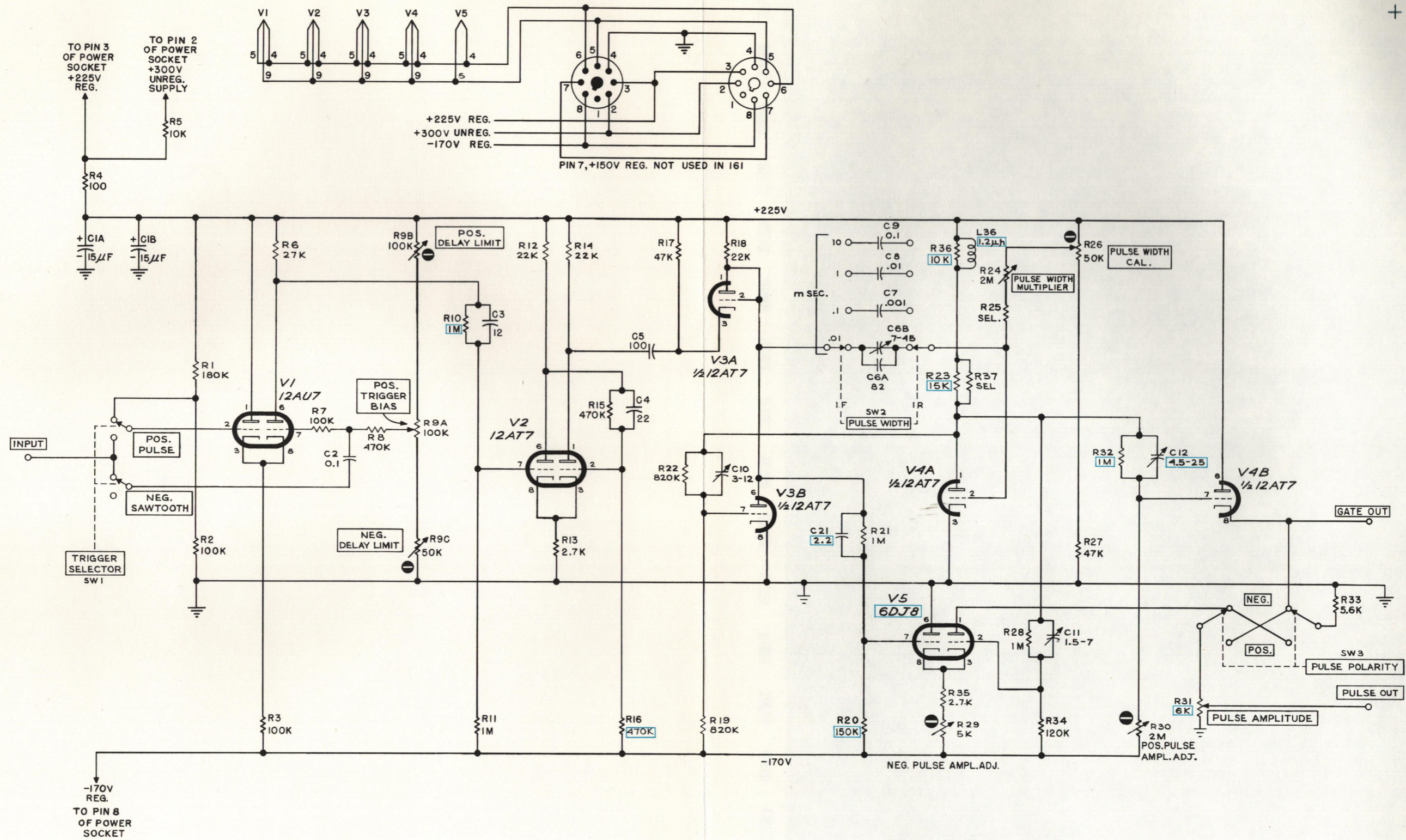

SEE PARTS LIST FOR EARLIER VALUES AND S/N CHANGES OF PARTS MARKED WITH BLUE OUTLINE

TYPE 161 PULSE GENERATOR

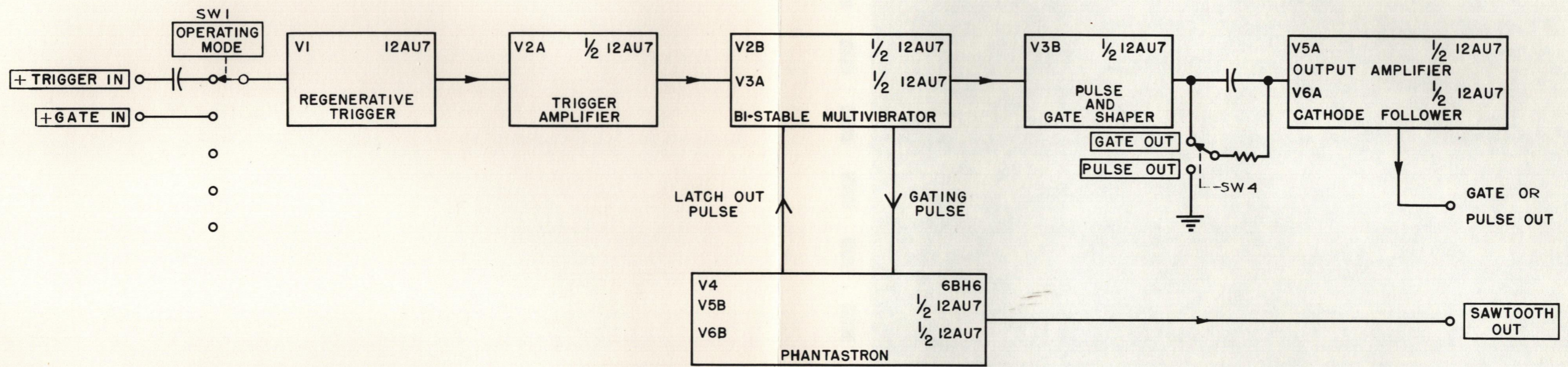

TYPE 162 WAVEFORM GENERATOR

AA<sub>1</sub>

L.A.P.  
11-5-62  
BLOCK DIAGRAM

BLOCK DIAGRAM

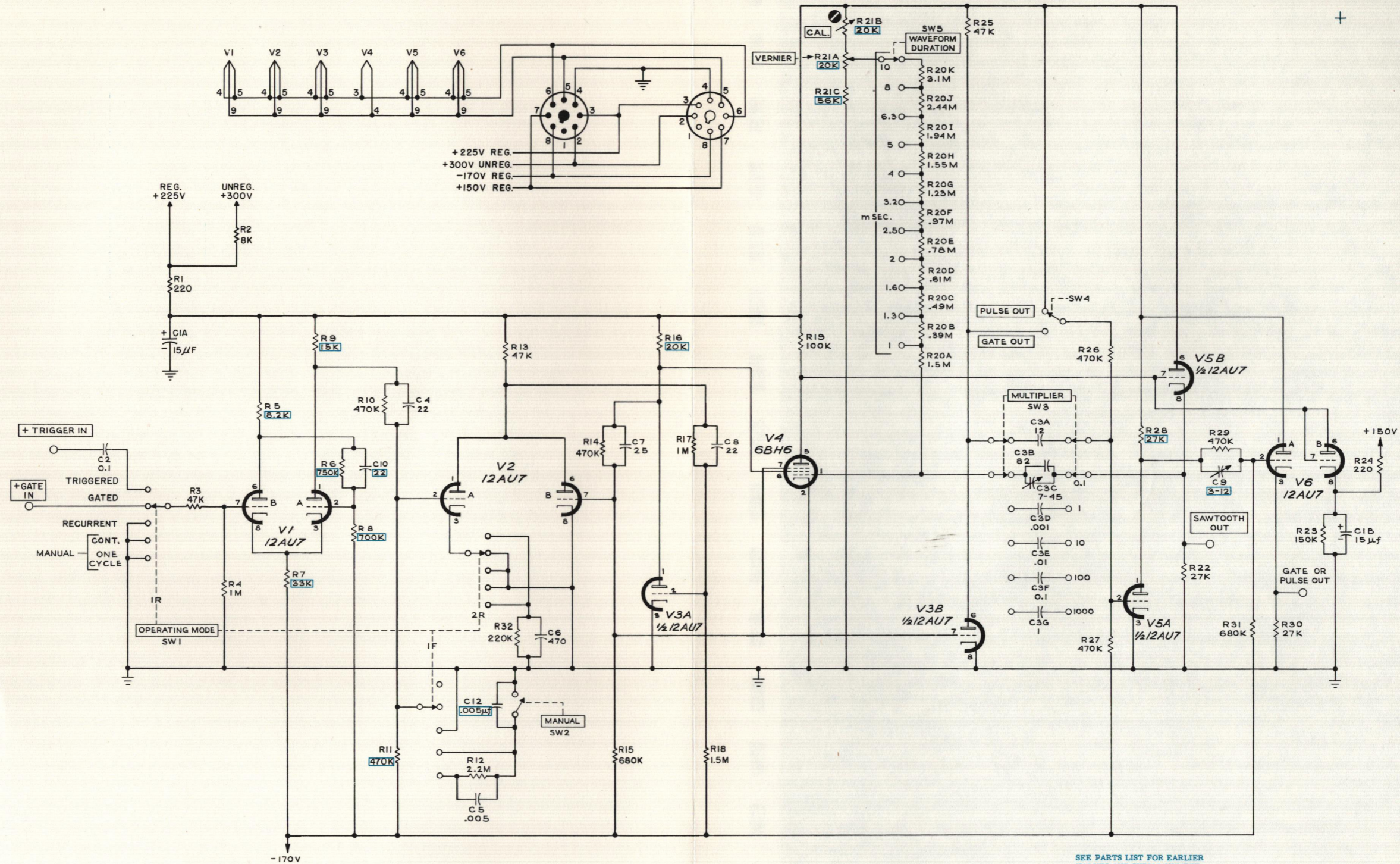

SEE PARTS LIST FOR EARLIER VALUES AND SERIAL NUMBER RANGES OF PARTS MARKED WITH BLUE OUTLINE.

+

AD

TYPE 162 WAVEFORM GENERATOR

CMD 667

162 WAVEFORM GENERATOR

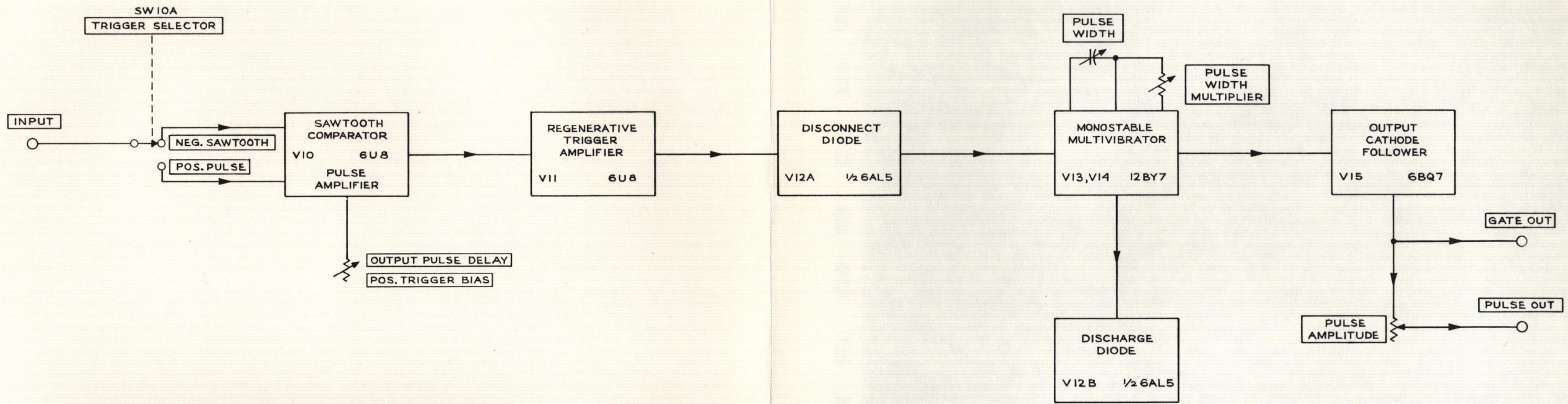

TYPE 163 PULSE GENERATOR

AA,

CMD  
10-31-62

BLOCK DIAGRAM



COMPARATOR

REGENERATIVE TRIGGER AMPLIFIER

DISCONNECT DIODE

MULTIVIBRATOR

DISCHARGE DIODE

CATHODE FOLLOWER

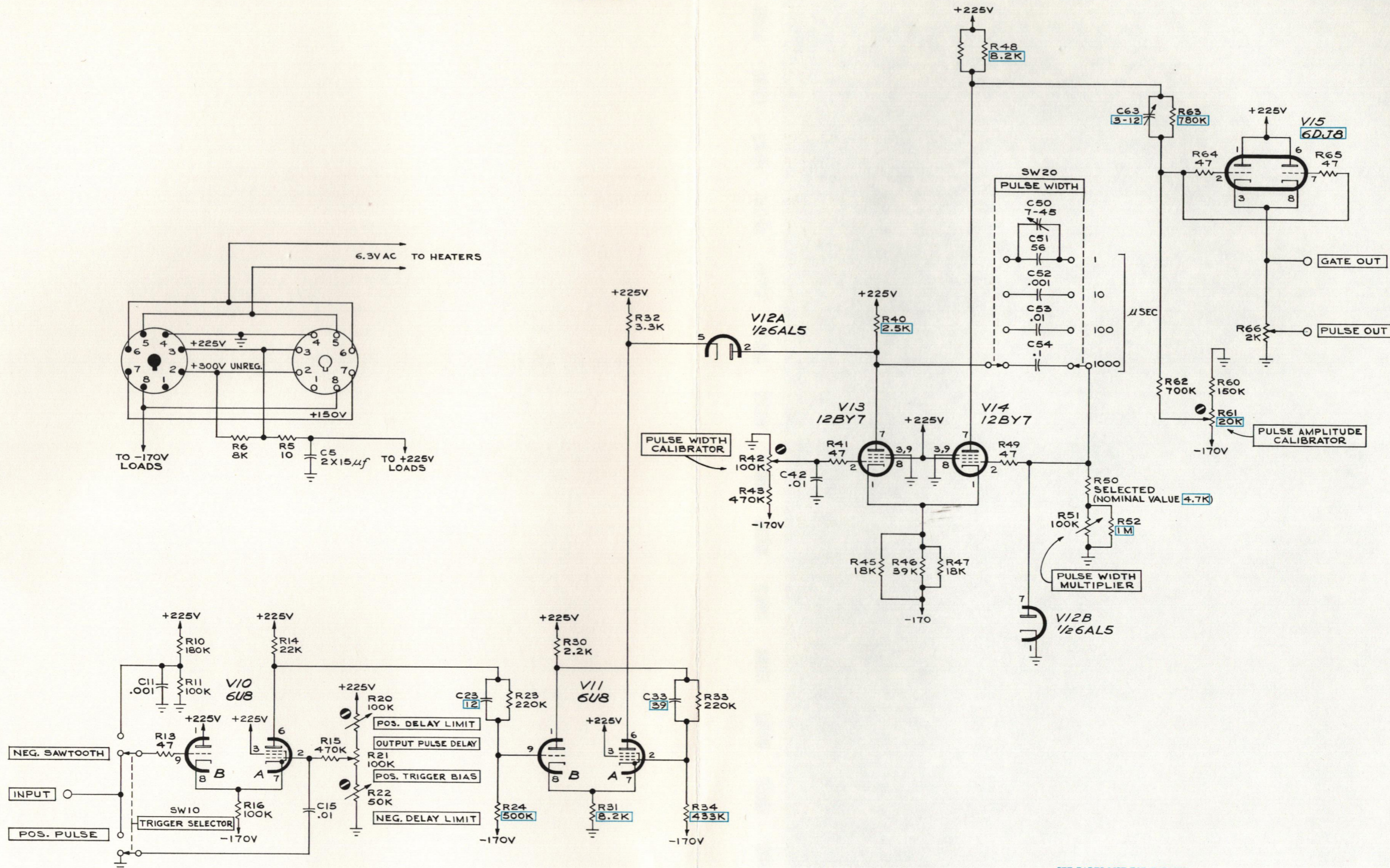

SEE PARTS LIST FOR EARLIER VALUES AND SERIAL NUMBER RANGES OF PARTS MARKED WITH BLUE OUTLINE.

AD

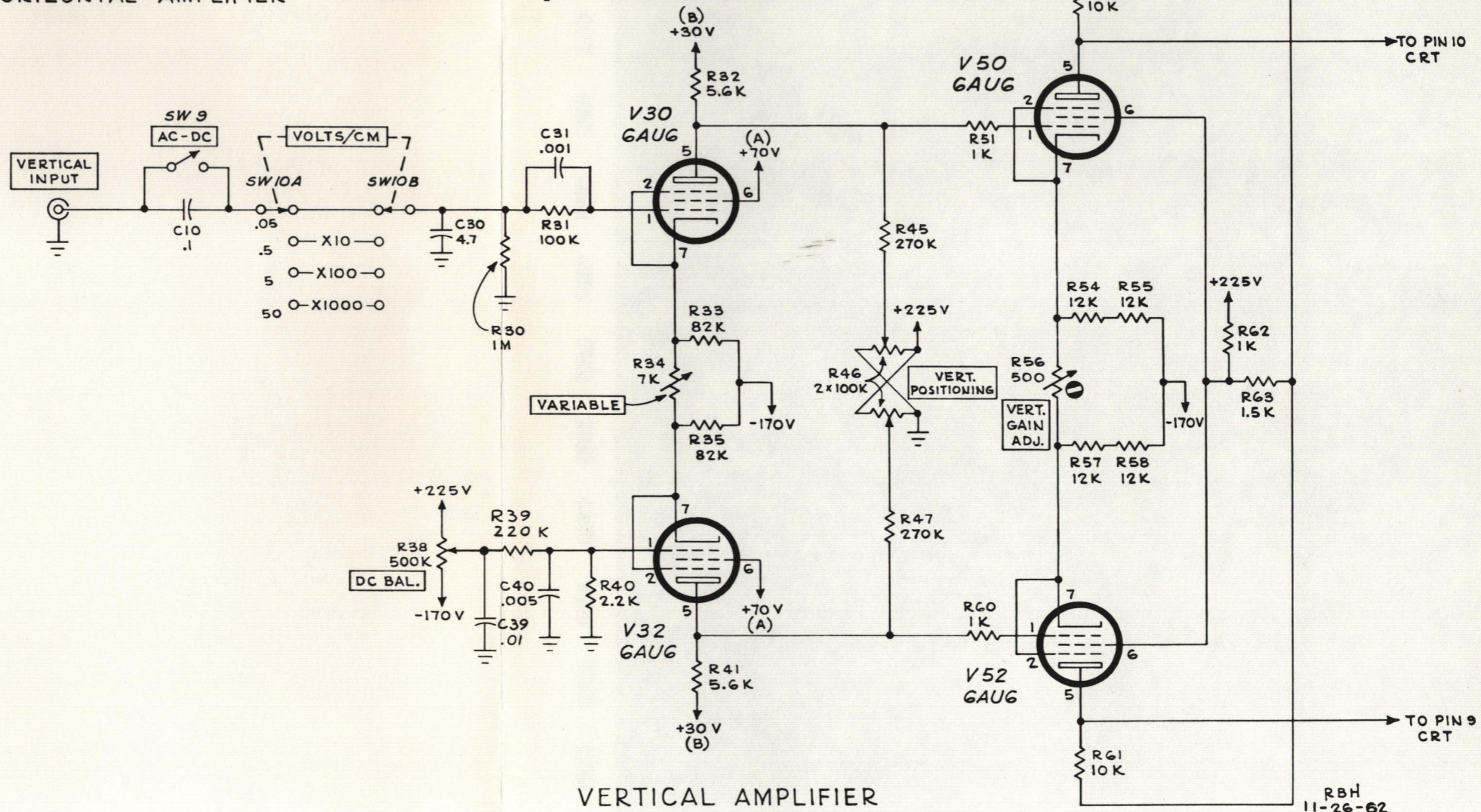
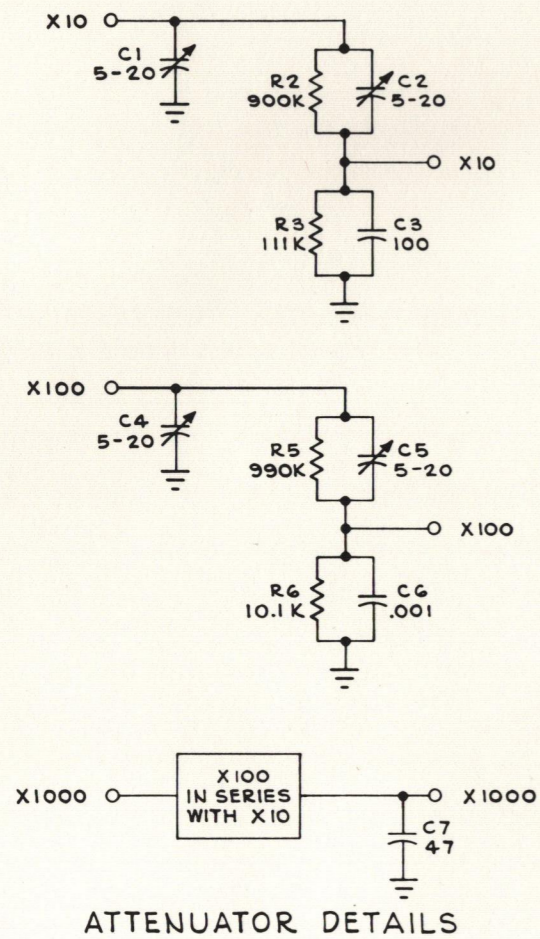
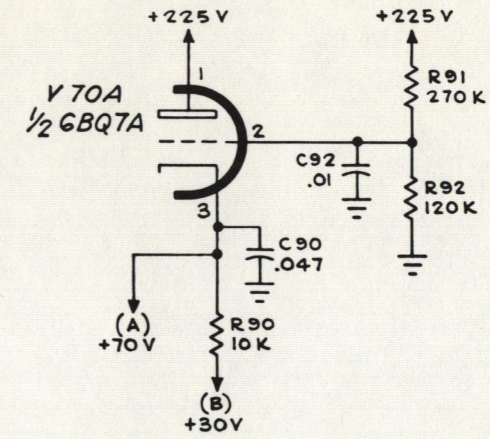
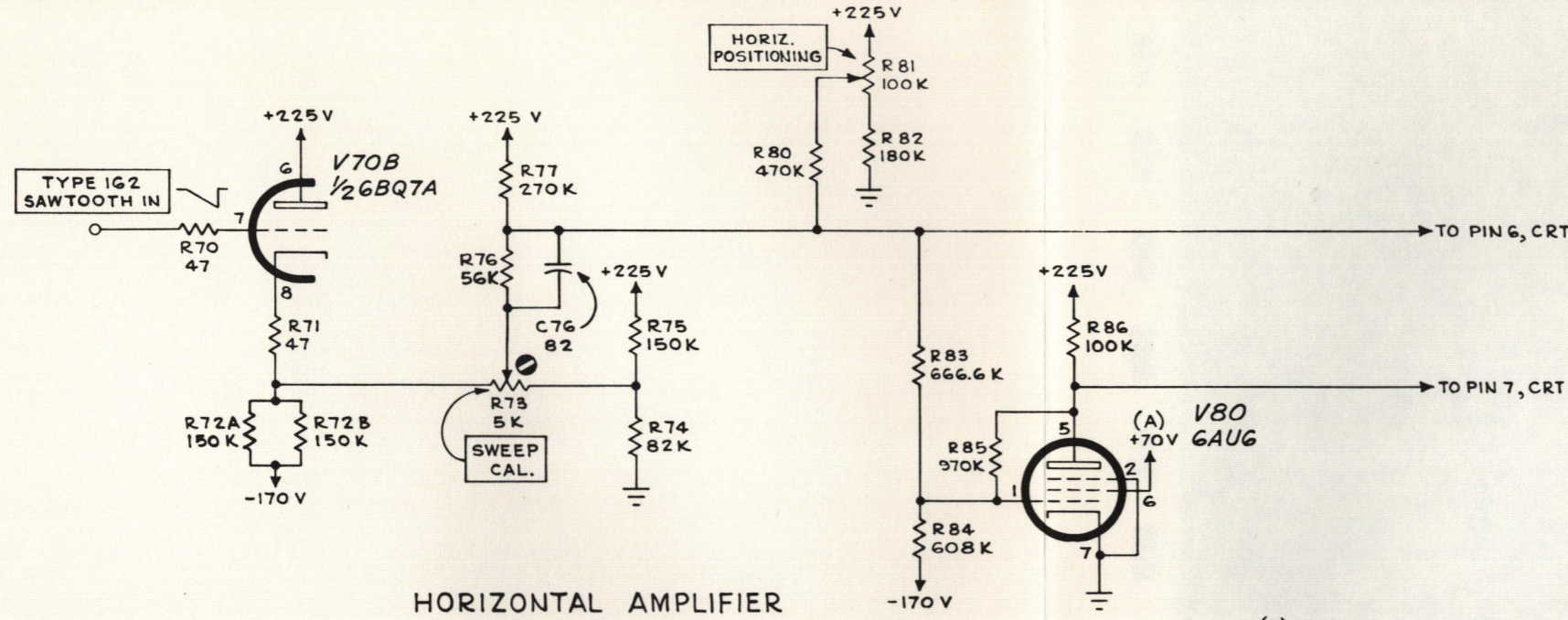

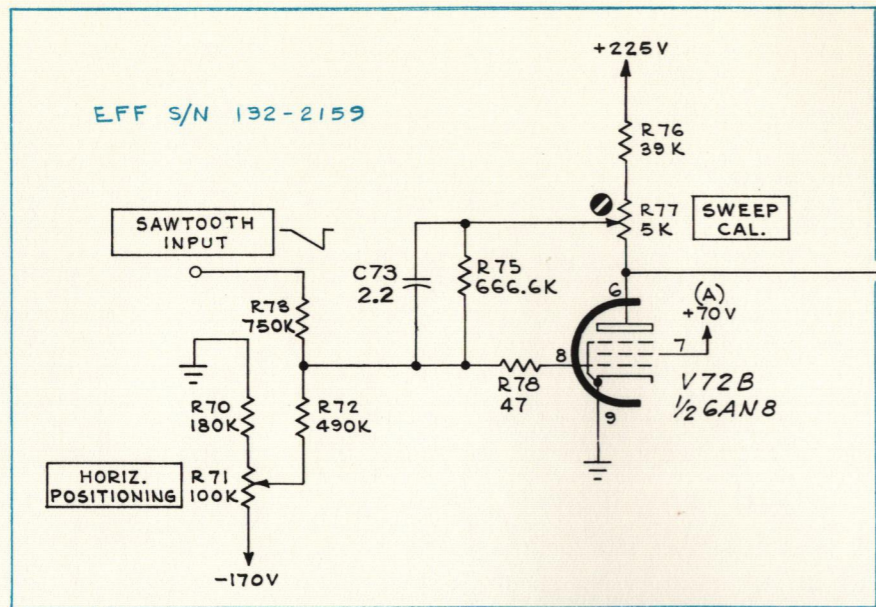

HORIZONTAL AMPLIFIER

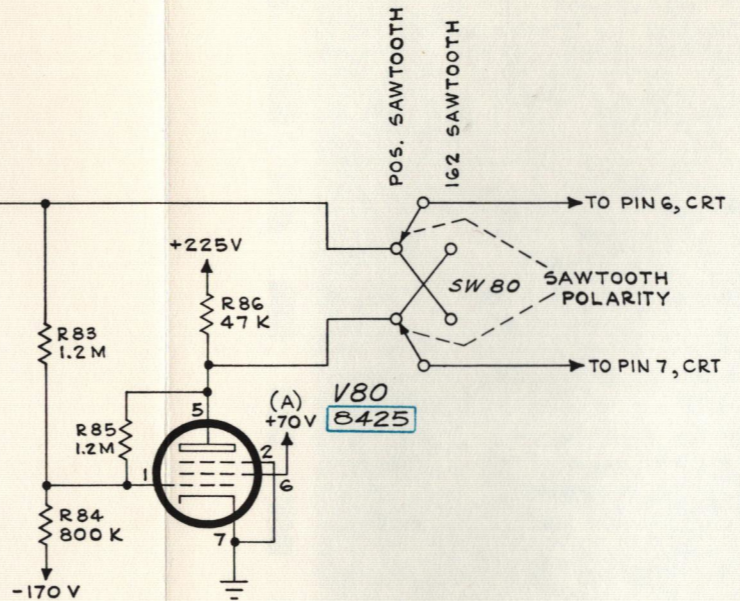

VERTICAL AMPLIFIER

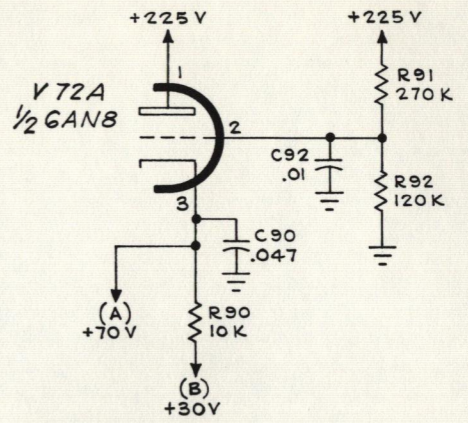

AMPLIFIERS  
S/N 132-UP

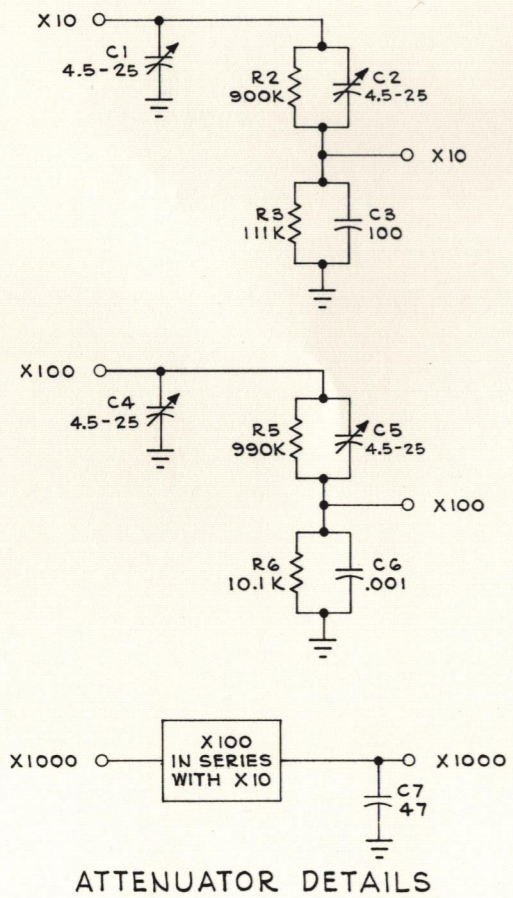

ATTENUATOR DETAILS

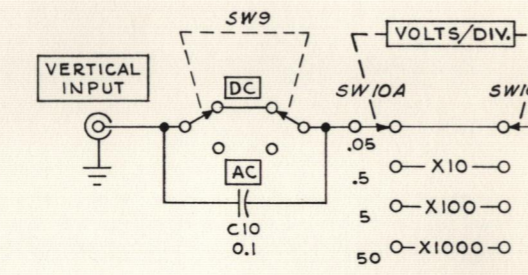

SEE PARTS LIST FOR EARLIER VALUES AND S/N CHANGES OF PARTS MARKED WITH BLUE OUTLINE

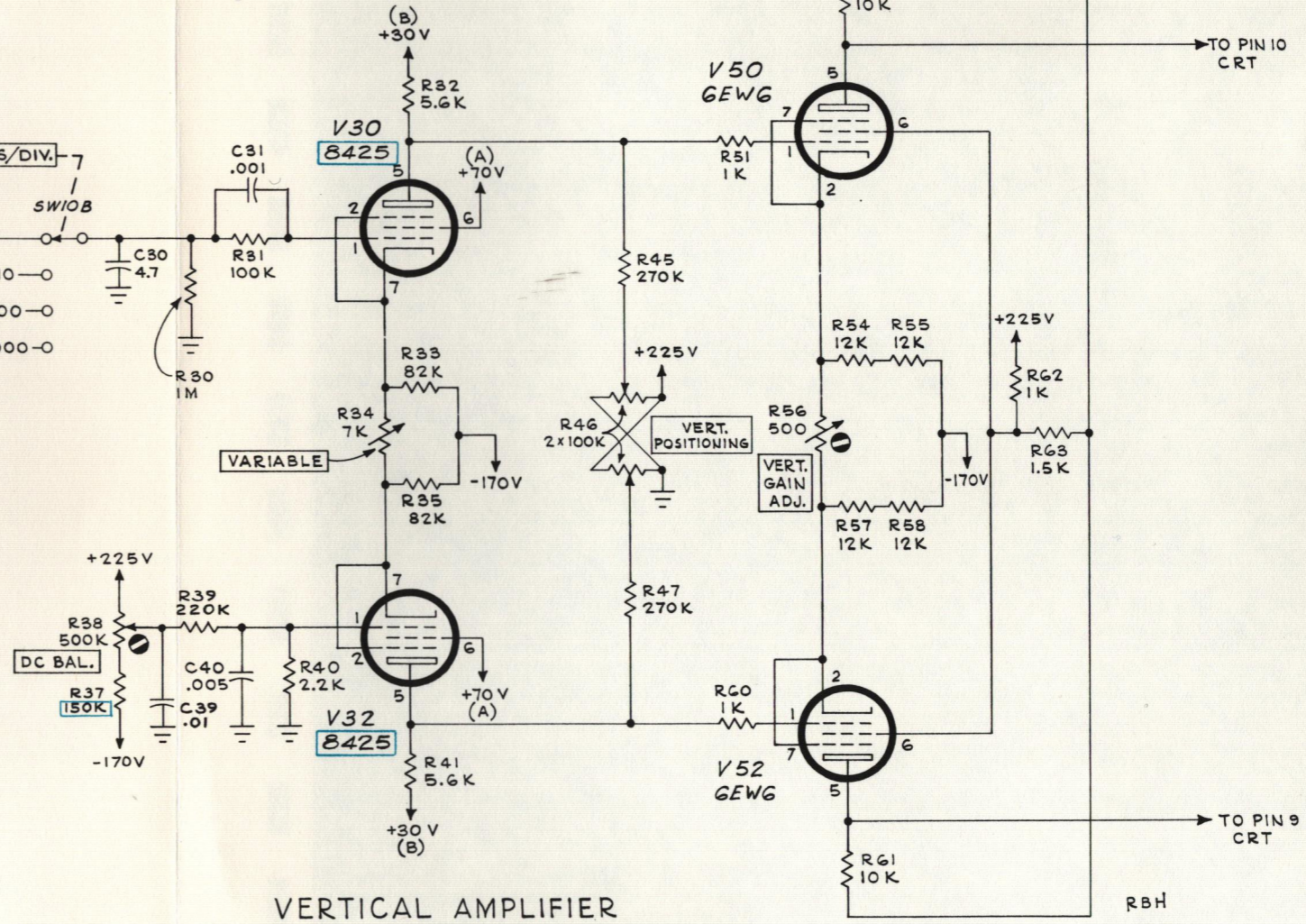

TYPE 360 INDICATOR

AD1

AMPLIFIERS

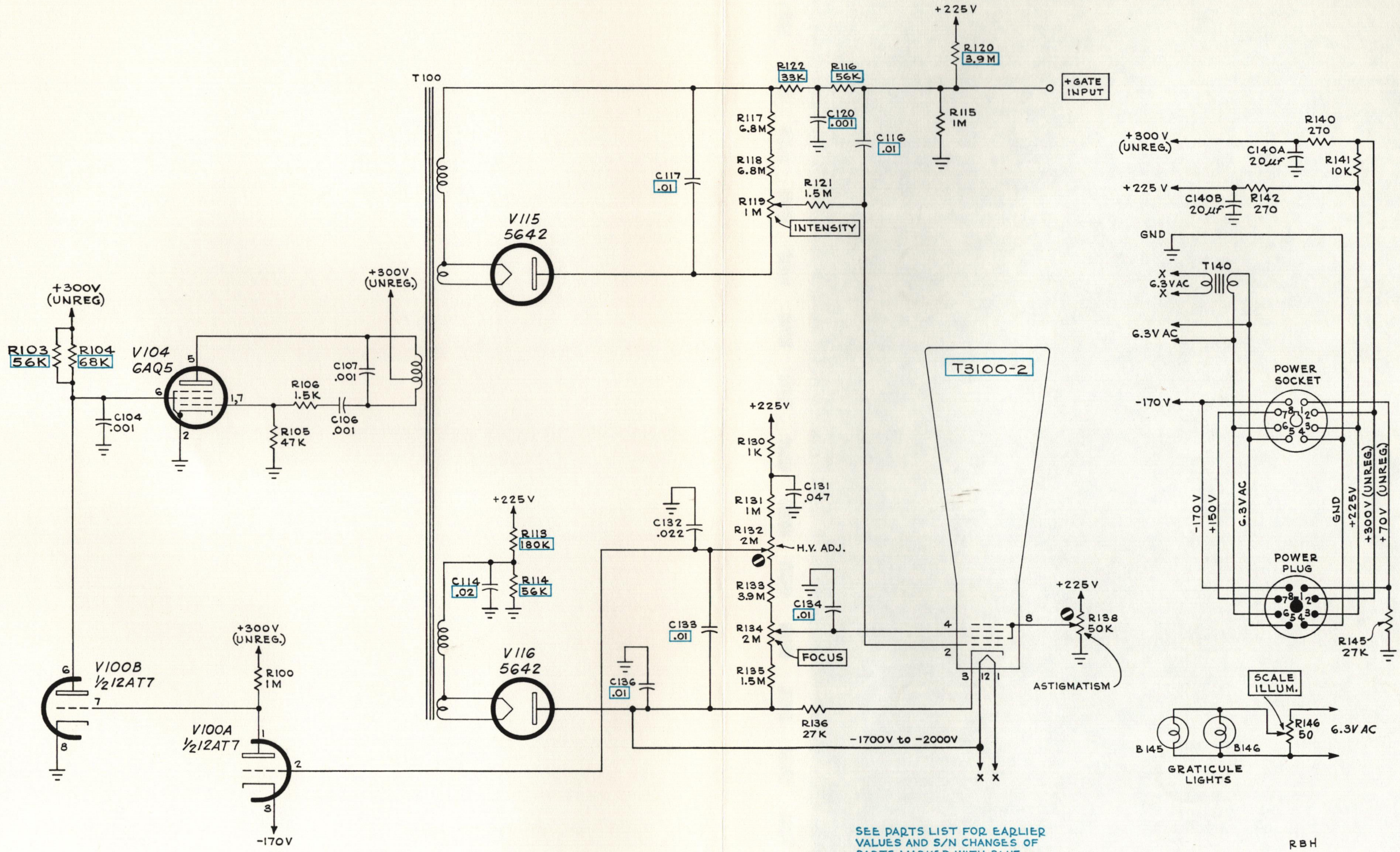

TYPE 360 INDICATOR

AC

CRT CIRCUIT

SEE PARTS LIST FOR EARLIER  
VALUES AND S/N CHANGES OF  
PARTS MARKED WITH BLUE  
OUTLINE

RBH  
1264

FIG. 1 TYPE 160 MECHANICAL PARTS

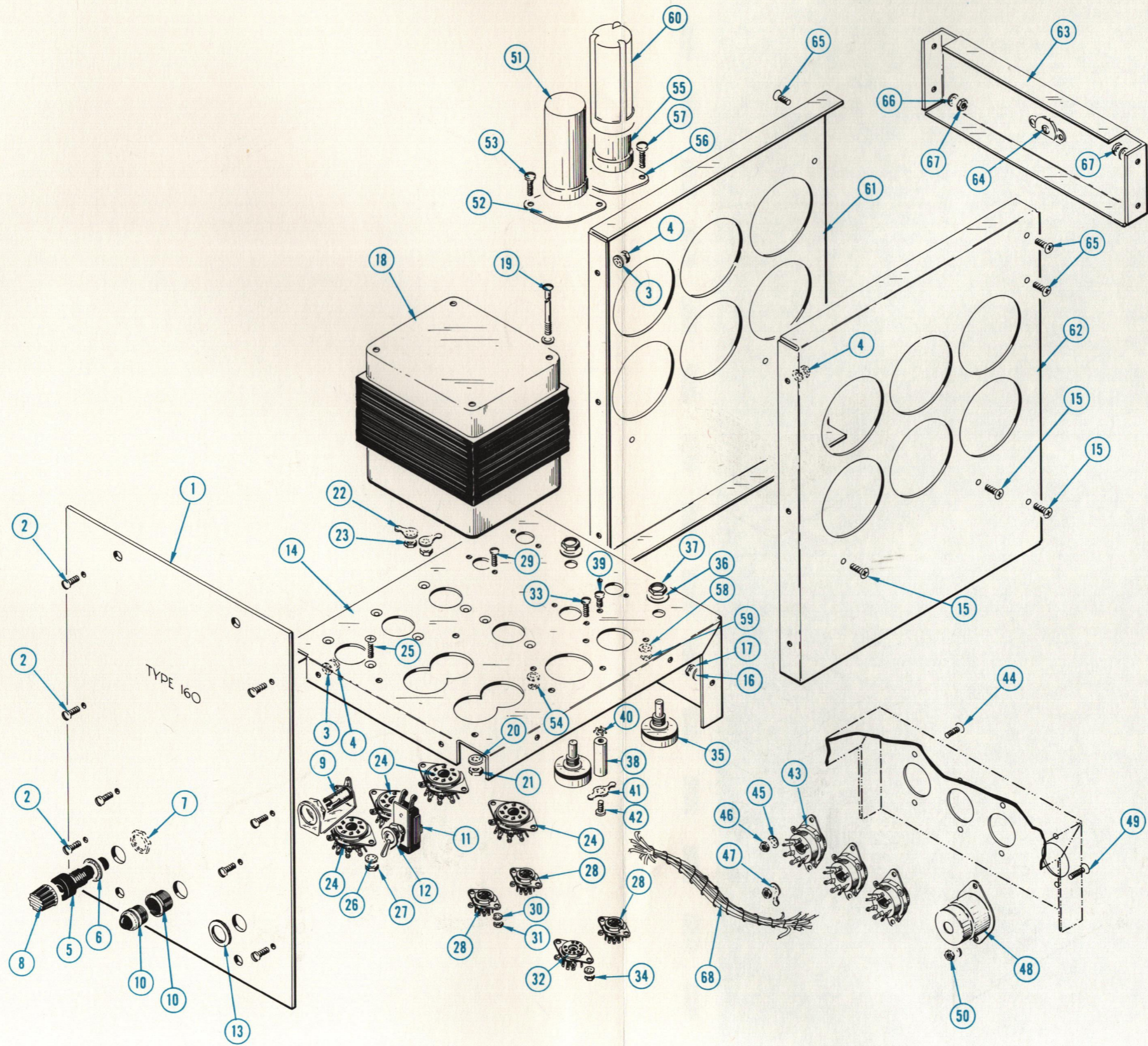

+

FIG. 2 TYPE 160A MECHANICAL PARTS

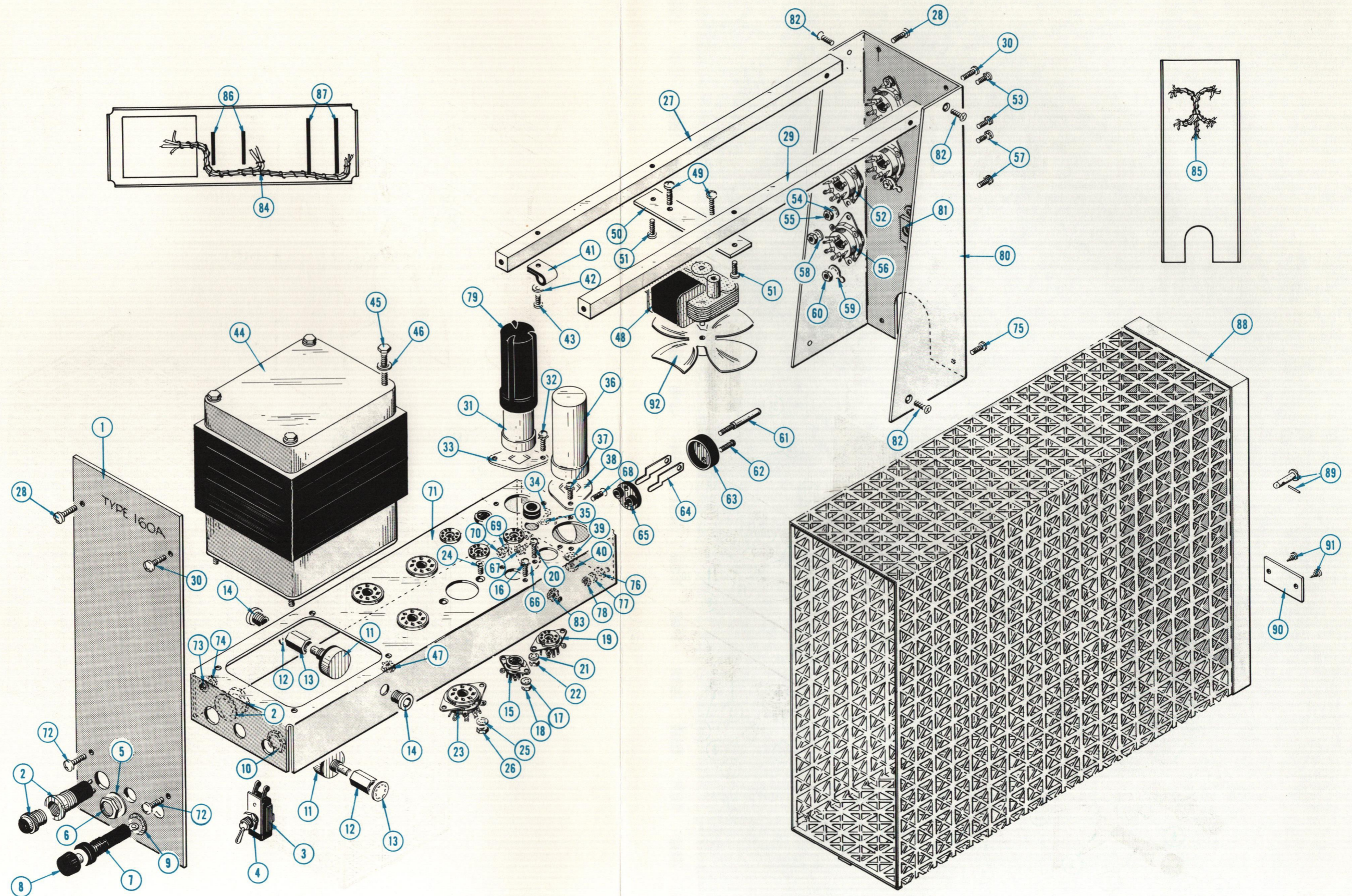

FIG. 3 TYPE 161 MECHANICAL PARTS

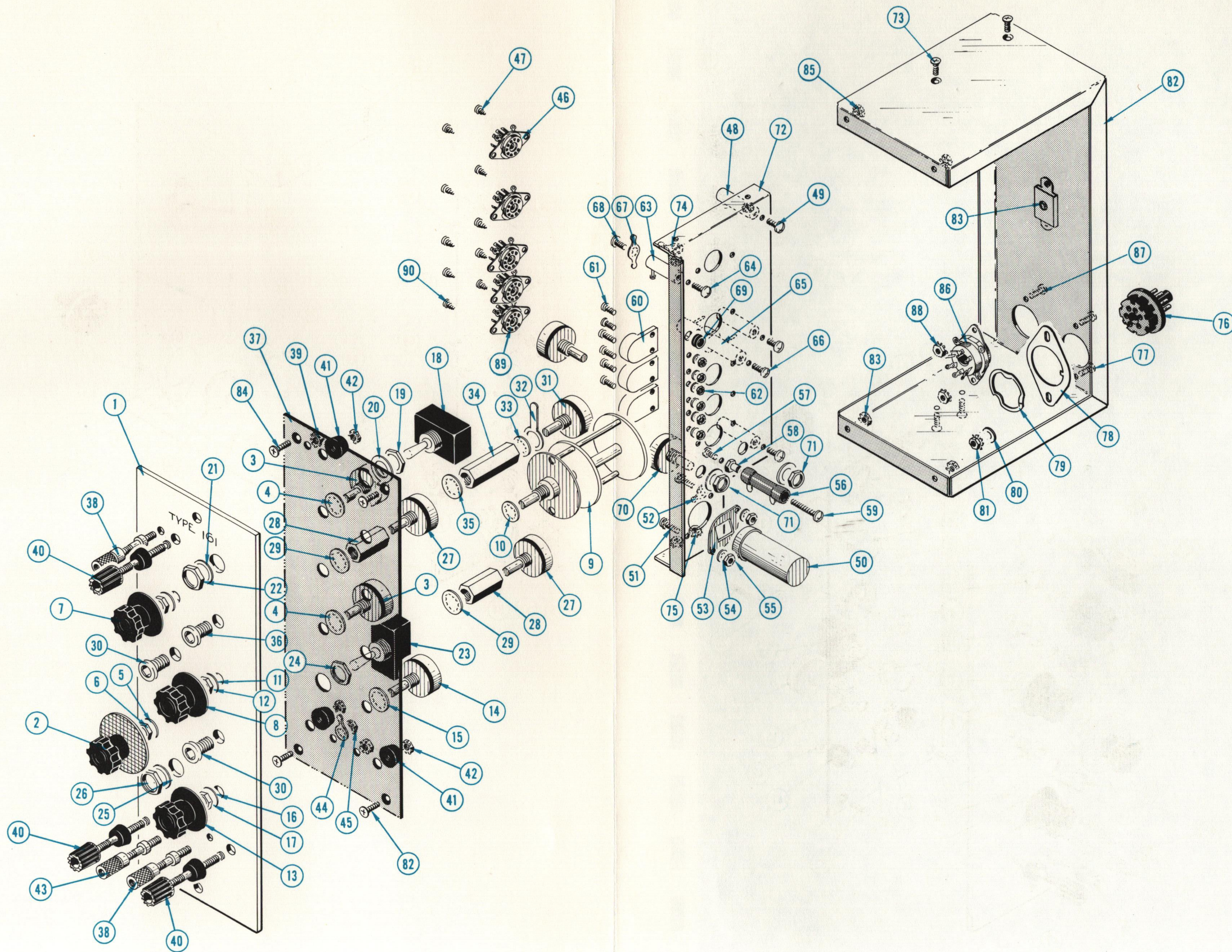

FIG. 4 TYPE 162 MECHANICAL PARTS

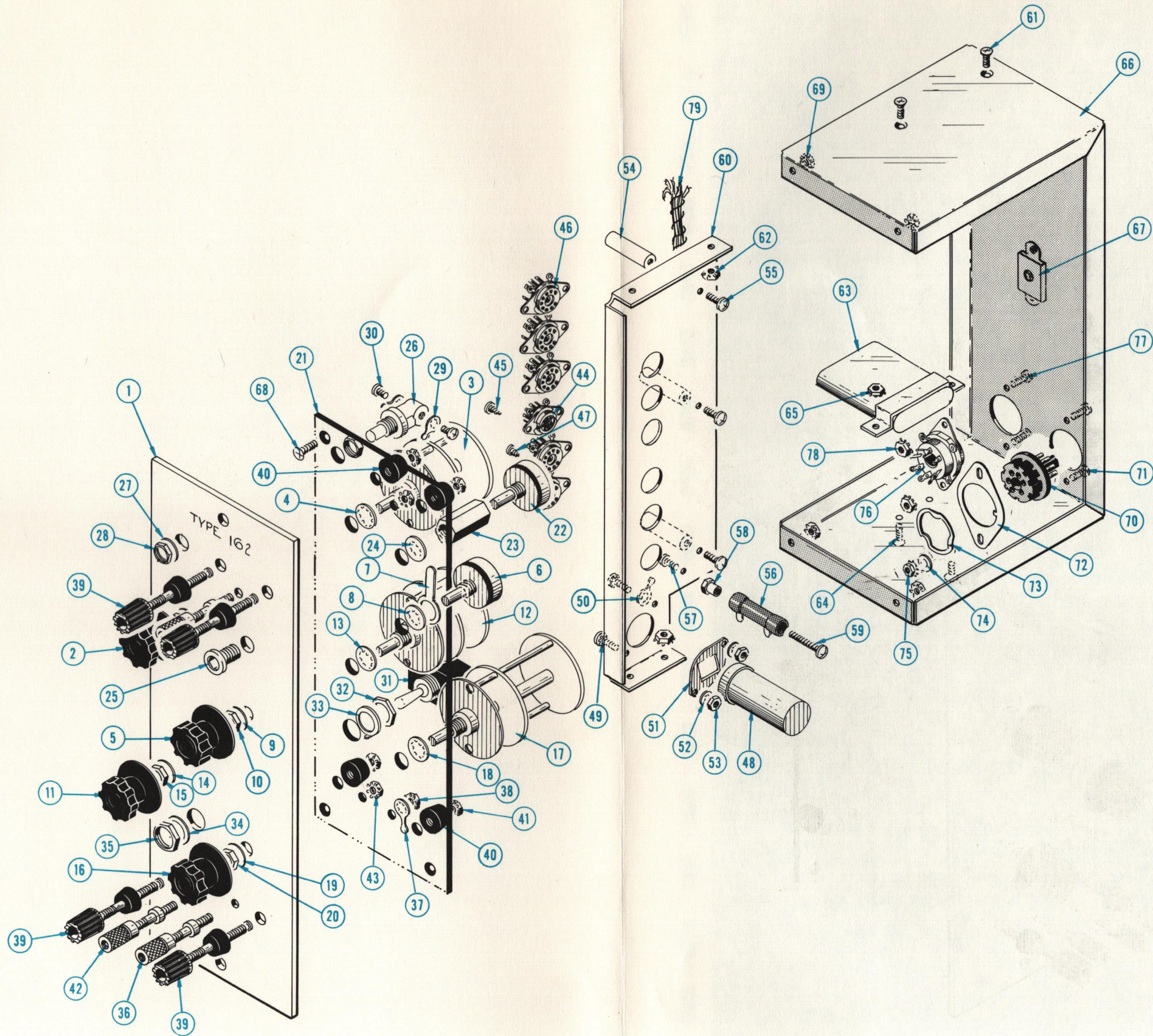



FIG. 5 TYPE 163 MECHANICAL PARTS

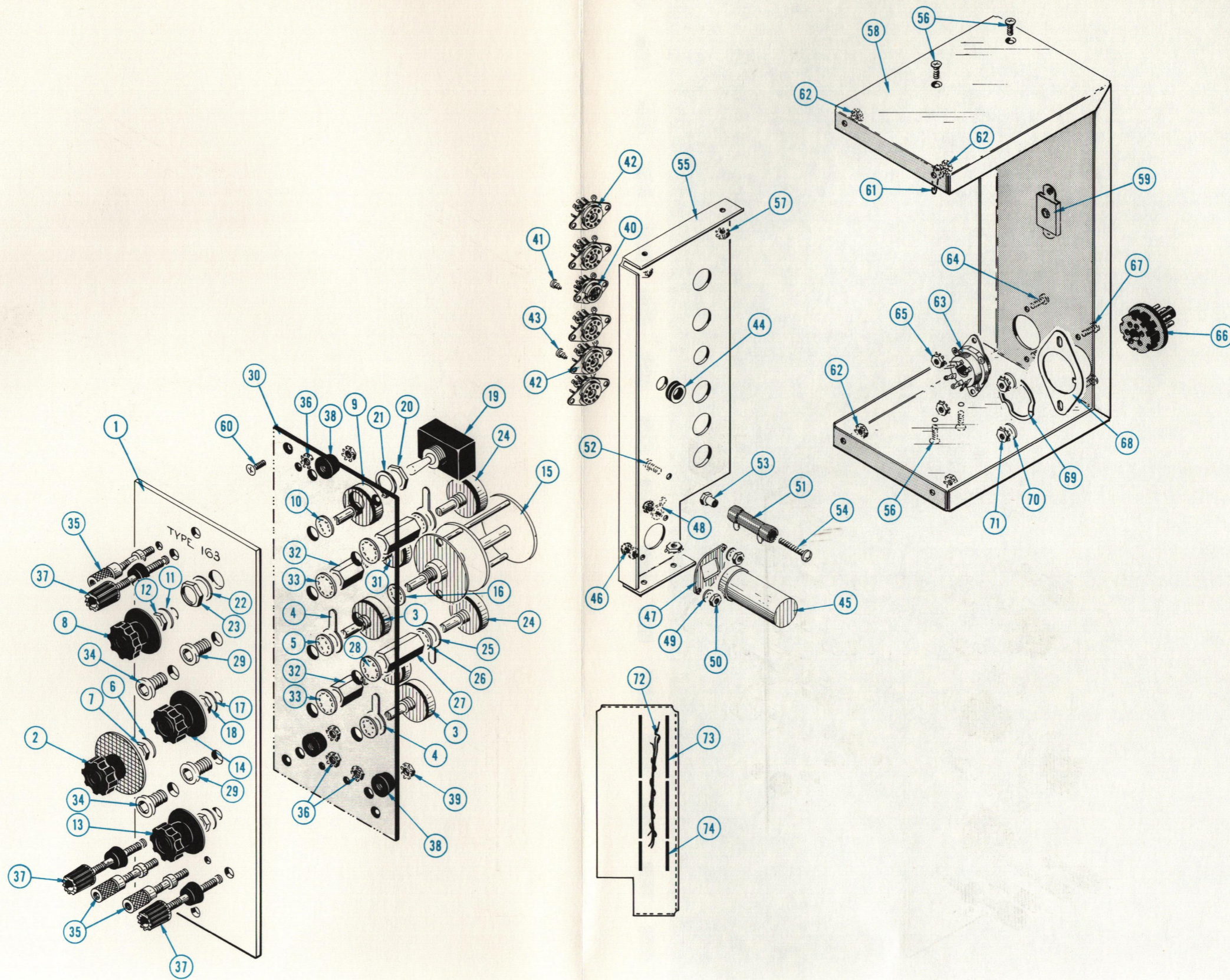

FIG. 6 TYPE 360 FRONT

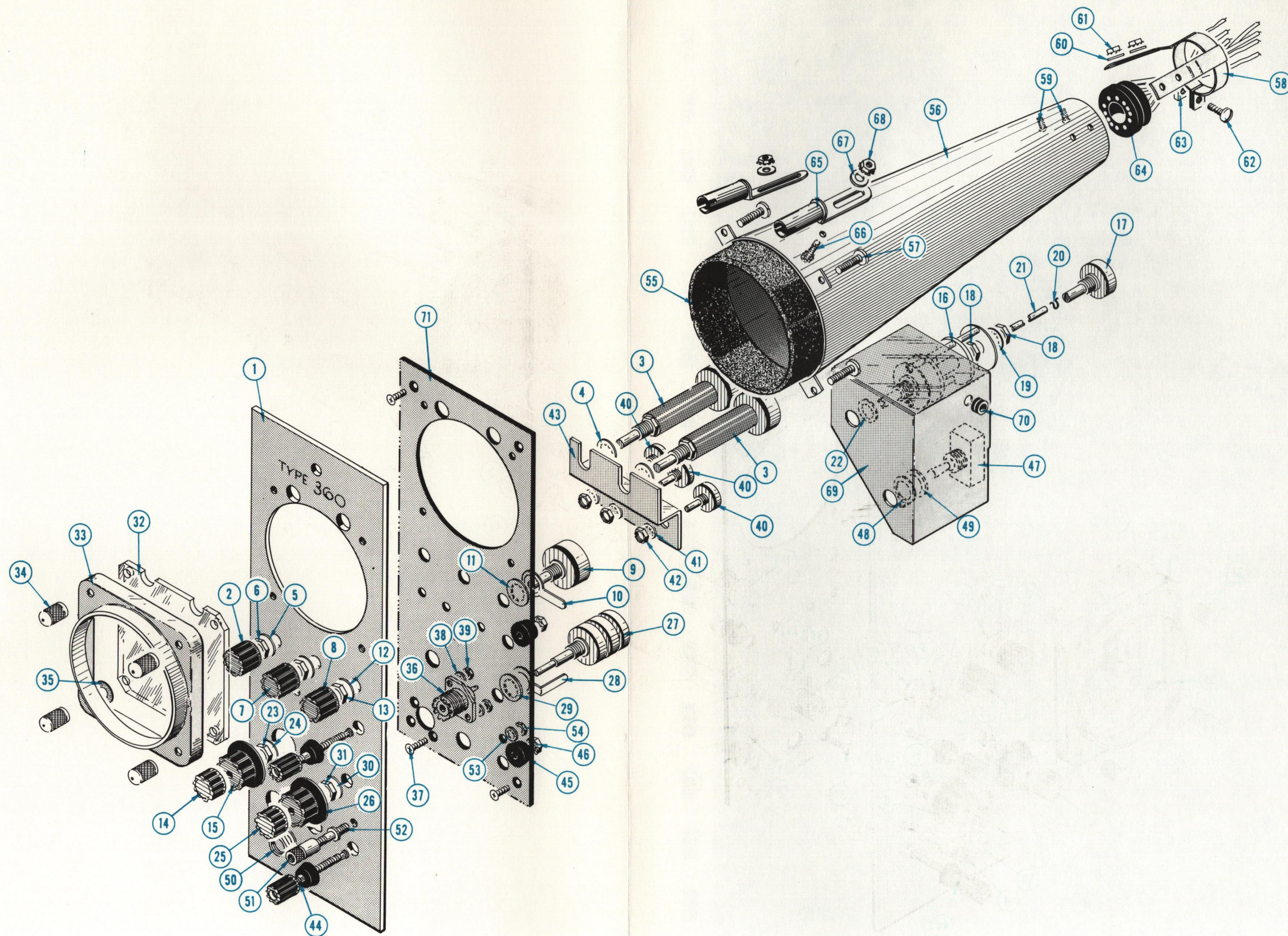

FIG. 7 TYPE 360 CHASSIS & REAR

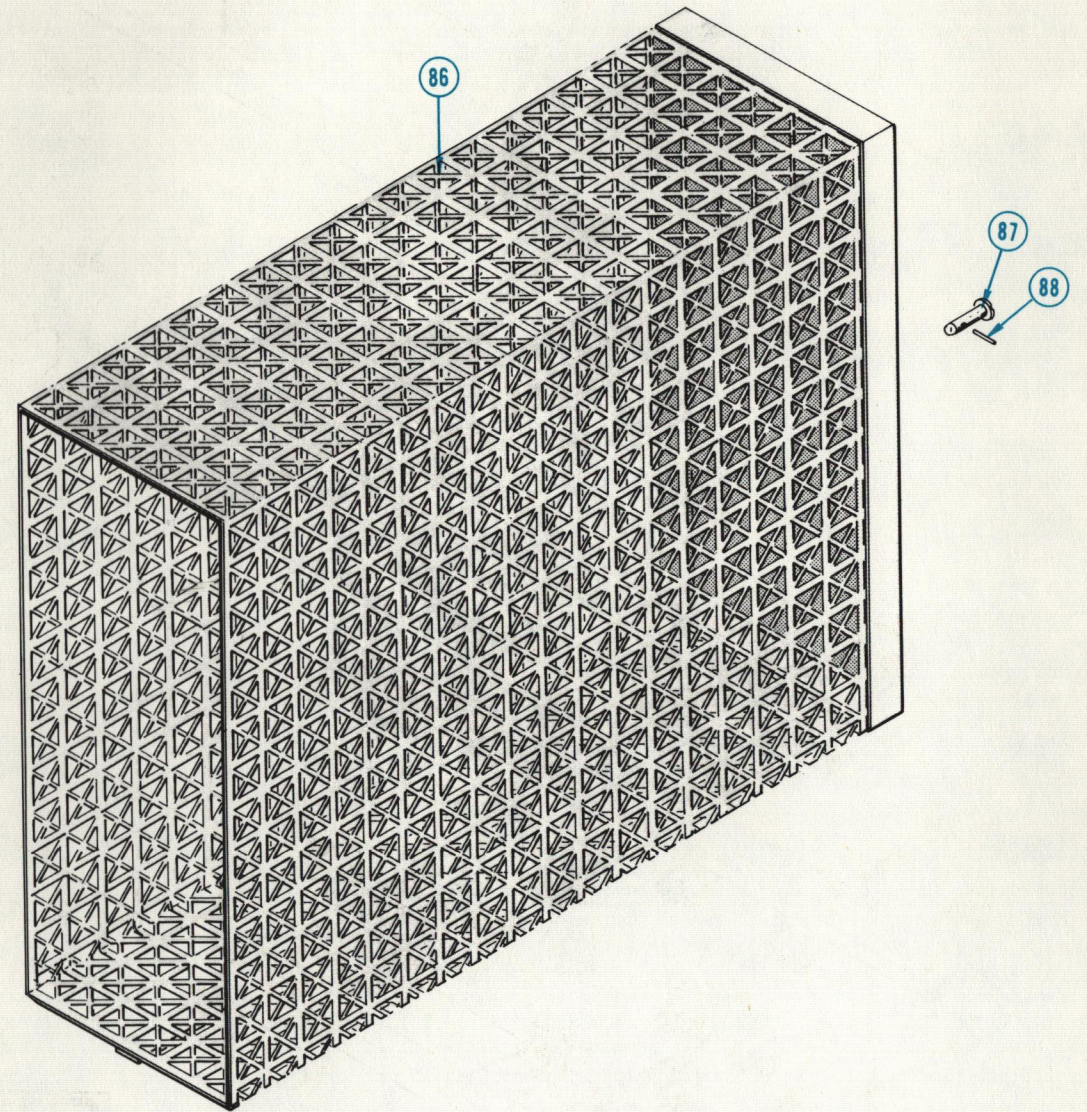
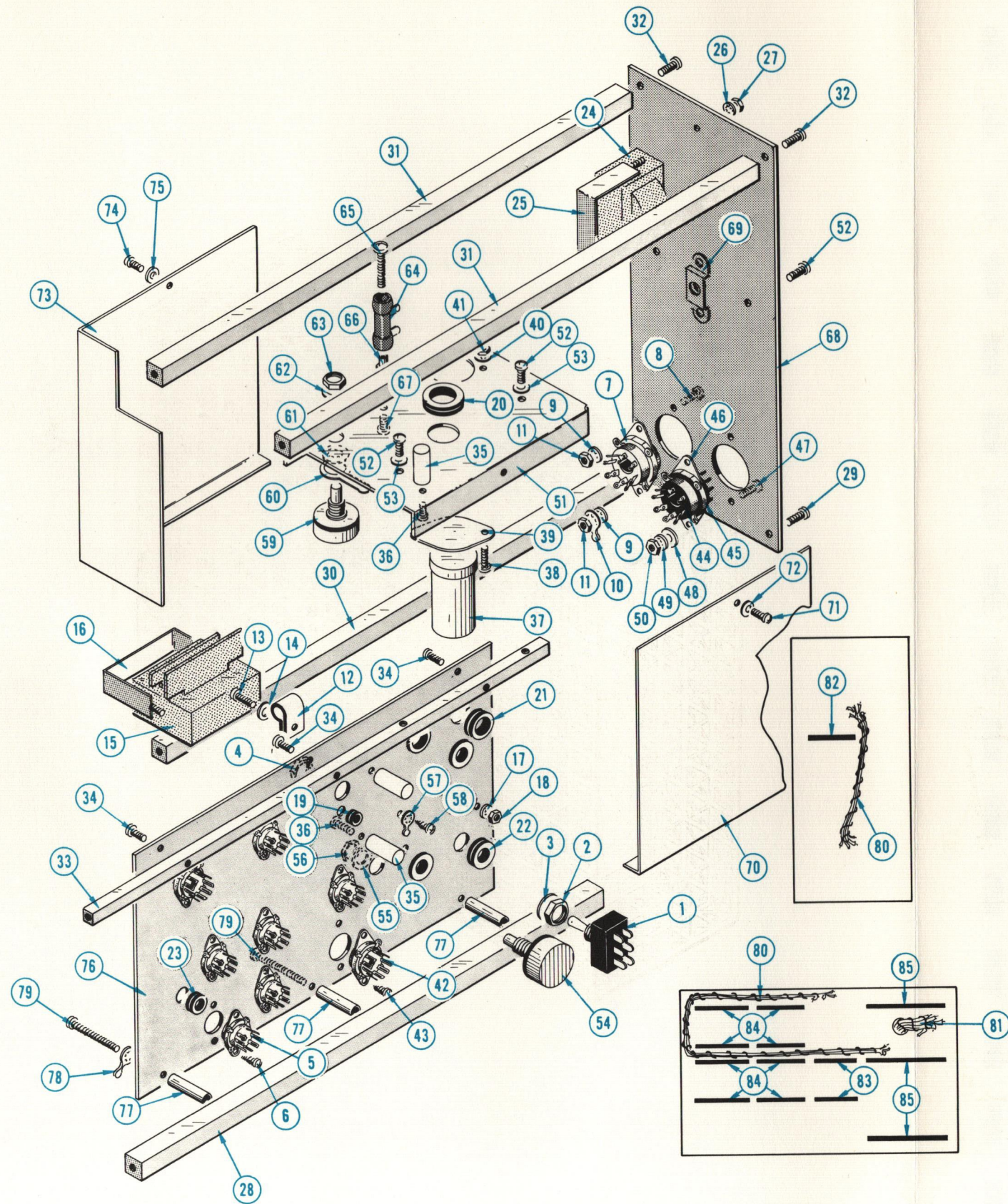
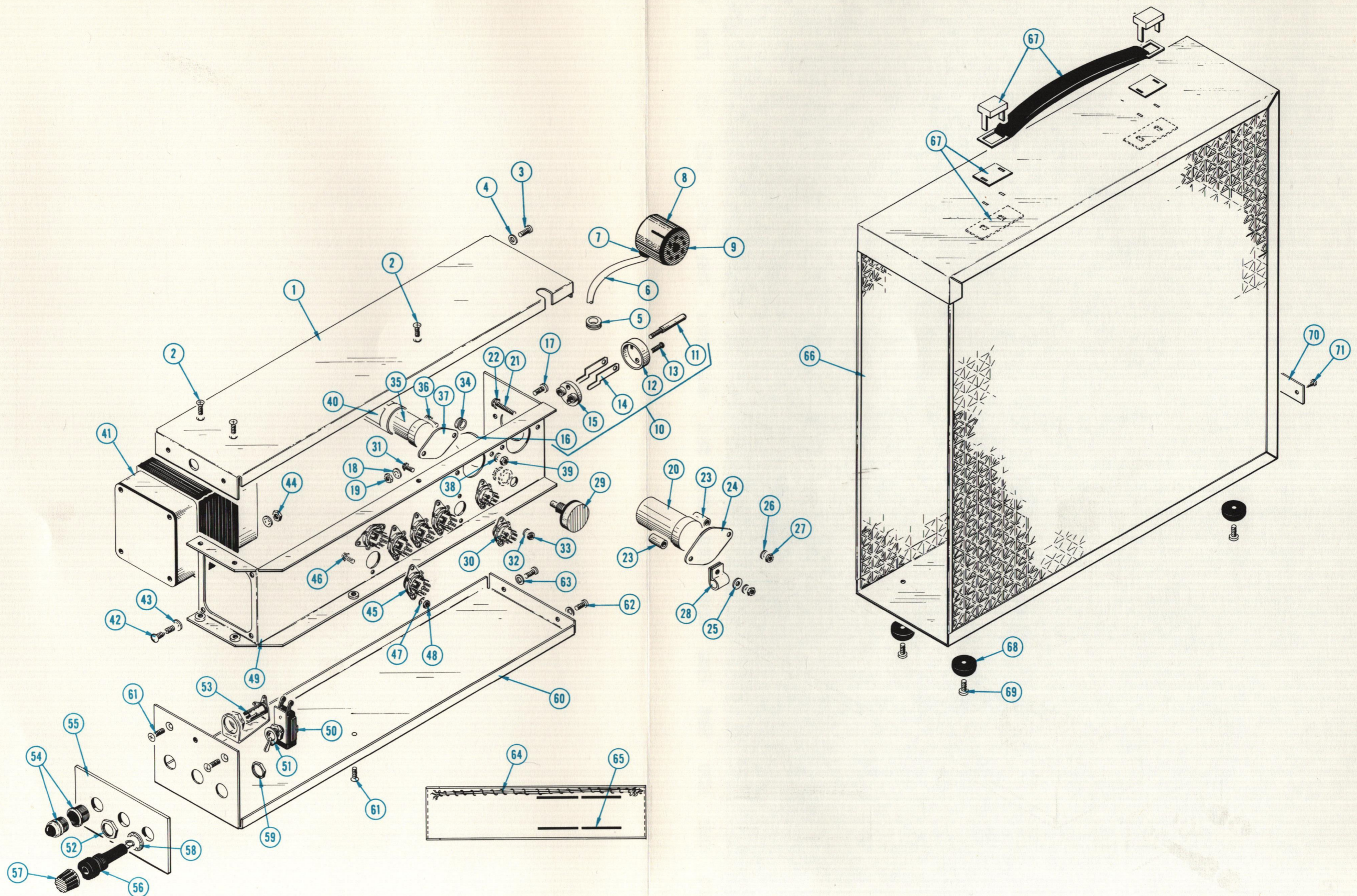
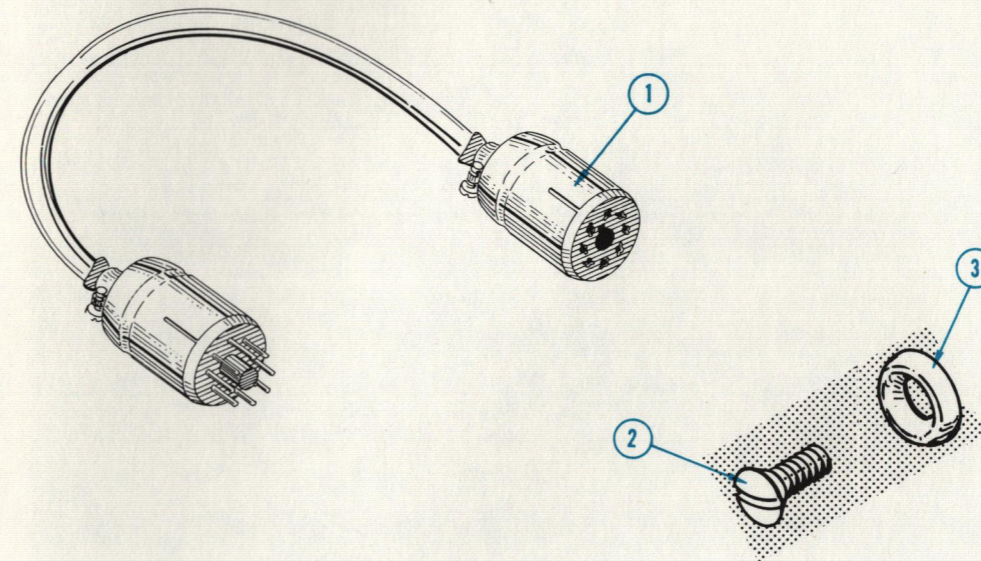

FIG. 8 TYPE 126 MECHANICAL PARTS & CABINET



TYPE 160 SERIES

FIG. 9 TYPE 160 STANDARD ACCESSORIES



A

Fig. & Index No.	Tektronix Part No.	Serial/Model No. Eff	No. Disc	Q					Description	
				t	y	1	2	3		4
9-1	012-0017-00			2						CABLE, interconnecting
-2	212-0019-00			2						SCREW, 8-32 x 3/8 inch, OHS
-3	210-0832-00			2						WASHER, finishing, #8
	070-0220-01			1						MANUAL, instruction (not shown)

B/A

FIG. 10 TYPE 160A STANDARD ACCESSORIES

+

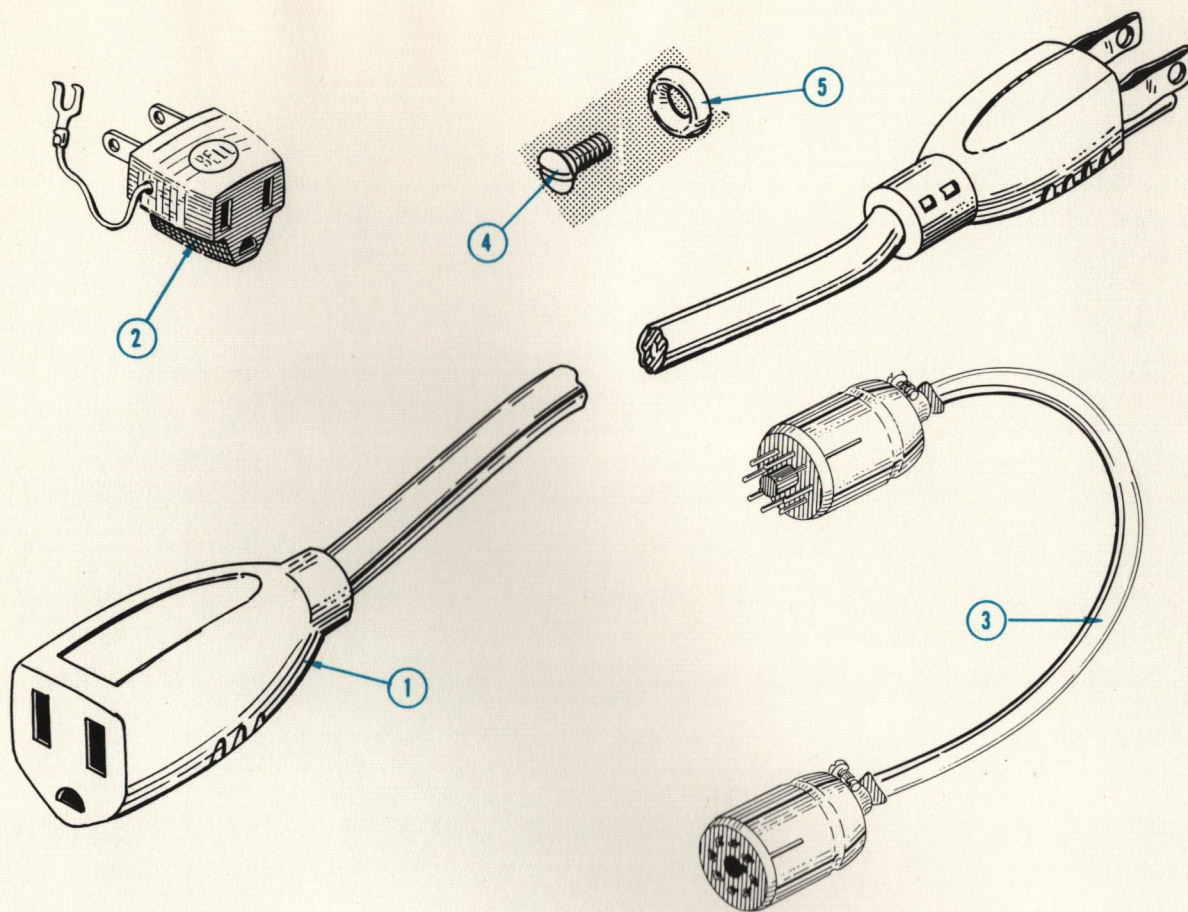

+ A

Fig. & Index No.	Tektronix Part No.	Serial/Model No.		Qty	Description
		Eff	Disc		
10-1	161-0001-00	620	3056	1	CORD, power, 16 ga., 8 foot, 2 wire
	161-0010-00	3057	11089	1	CORD, power, 16 ga., 8 foot, 3 wire
	161-0010-03	11090		1	CORD, power, 16 ga., 8 foot, 3 wire
-2	103-0013-00	X3057		1	ADAPTER, 3 to 2 wire
-3	012-0016-00			2	CABLE, interconnecting
-4	212-0019-00			2	SCREW, 8-32 x 3/8 inch, OHS
-5	210-0832-00			2	WASHER, finishing, #8
	070-0220-01			1	MANUAL, instruction (not shown)

B A

FIG. 10 160A ACCESSORIES

FIG. 11 TYPE 161 STANDARD ACCESSORIES

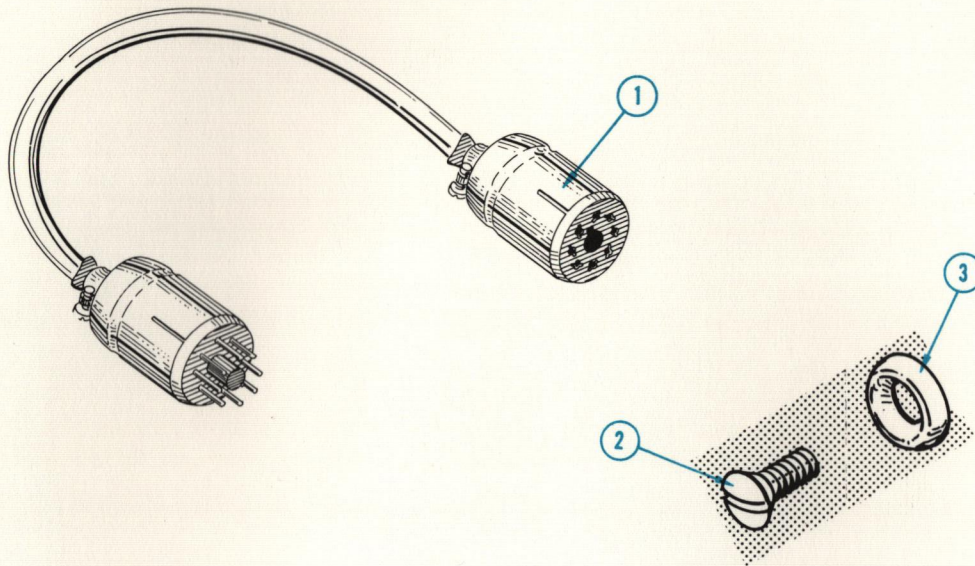

A

Fig. & Index No.	Tektronix Part No.	Serial/Model No. Eff	No. Disc	Q					Description	
				f	y	1	2	3		4
11-1	012-0017-00			1						CABLE, interconnecting
-2	212-0019-00			2						SCREW, 8-32 x 3/8 inch, OHS
-3	210-0832-00			2						WASHER, finishing, #8
	070-0220-01			1						MANUAL, instruction (not shown)

B(A)

FIG. 12 TYPE 162 STANDARD ACCESSORIES

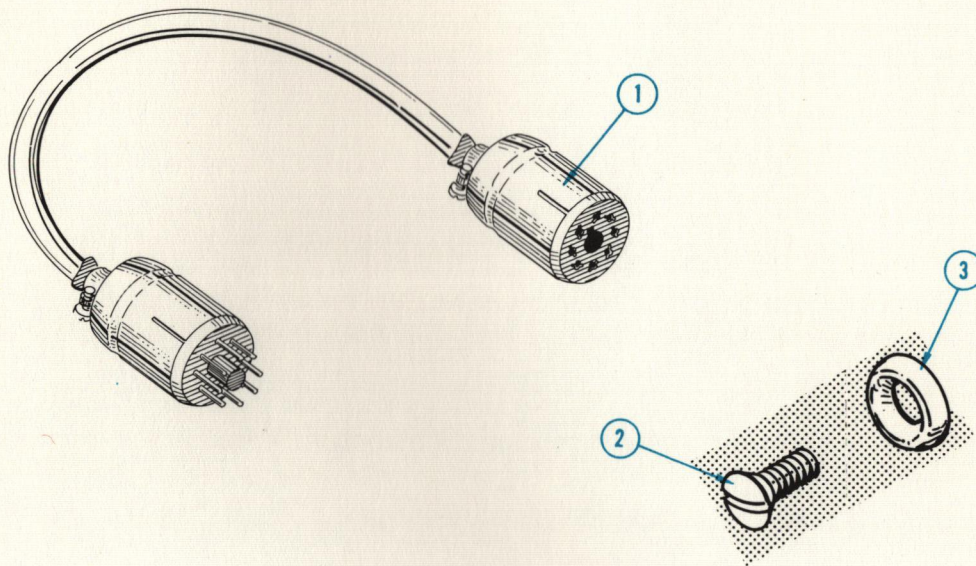

A

Fig. & Index No.	Tektronix Part No.	Serial/Model Eff	No. Disc	Q					Description	
				t	y	1	2	3		4
12-1	012-0017-00			1						CABLE, interconnecting
-2	212-0019-00			2						SCREW, 8-32 x 3/8 inch, OHS
-3	210-0832-00			2						WASHER, finishing, #8
	070-0220-01			1						MANUAL, instruction (not shown)

B/A



FIG. 13 TYPE 163 STANDARD ACCESSORIES

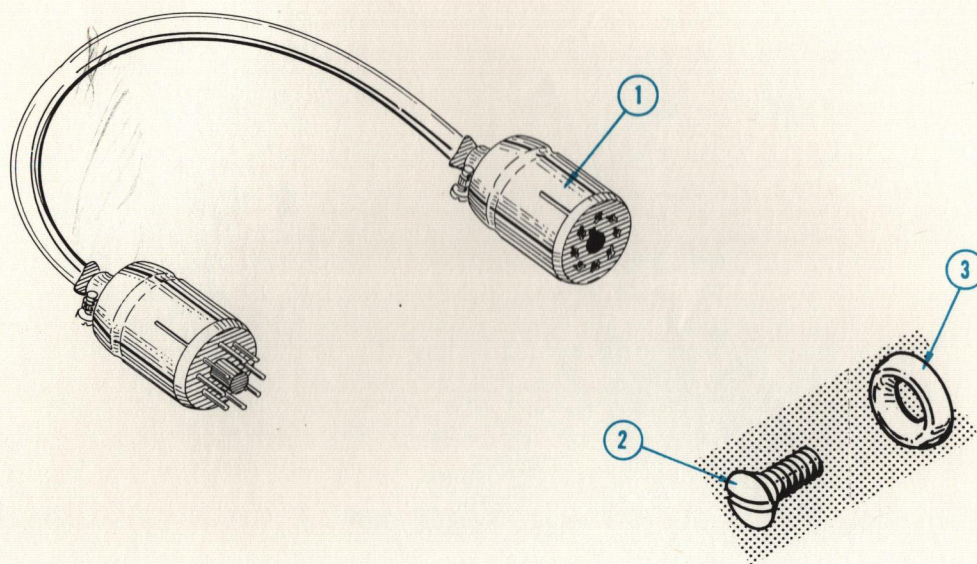

A

Fig. & Index No.	Tektronix Part No.	Serial/Model No.		Q						Description			
		Eff	Disc		t	y	1	2	3		4	5	
13-1	012-0017-00					1						1	CABLE, interconnecting
-2	212-0019-00											2	SCREW, 8-32 x 3/8 inch, OHS
-3	210-0832-00											2	WASHER, finishing, #8
	070-0220-01											1	MANUAL, instruction

B/A

FIG. 14 TYPE 360 STANDARD ACCESSORIES

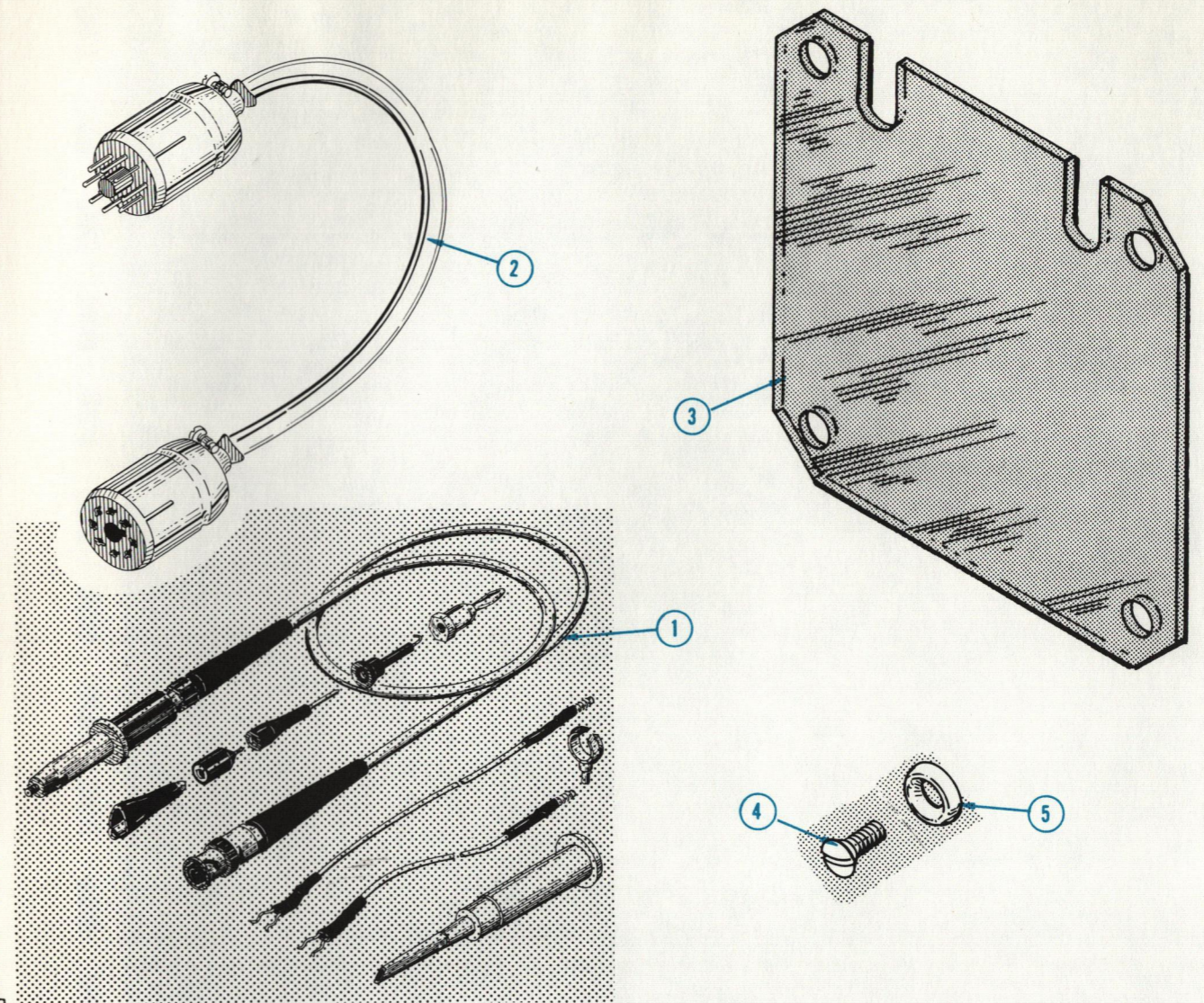
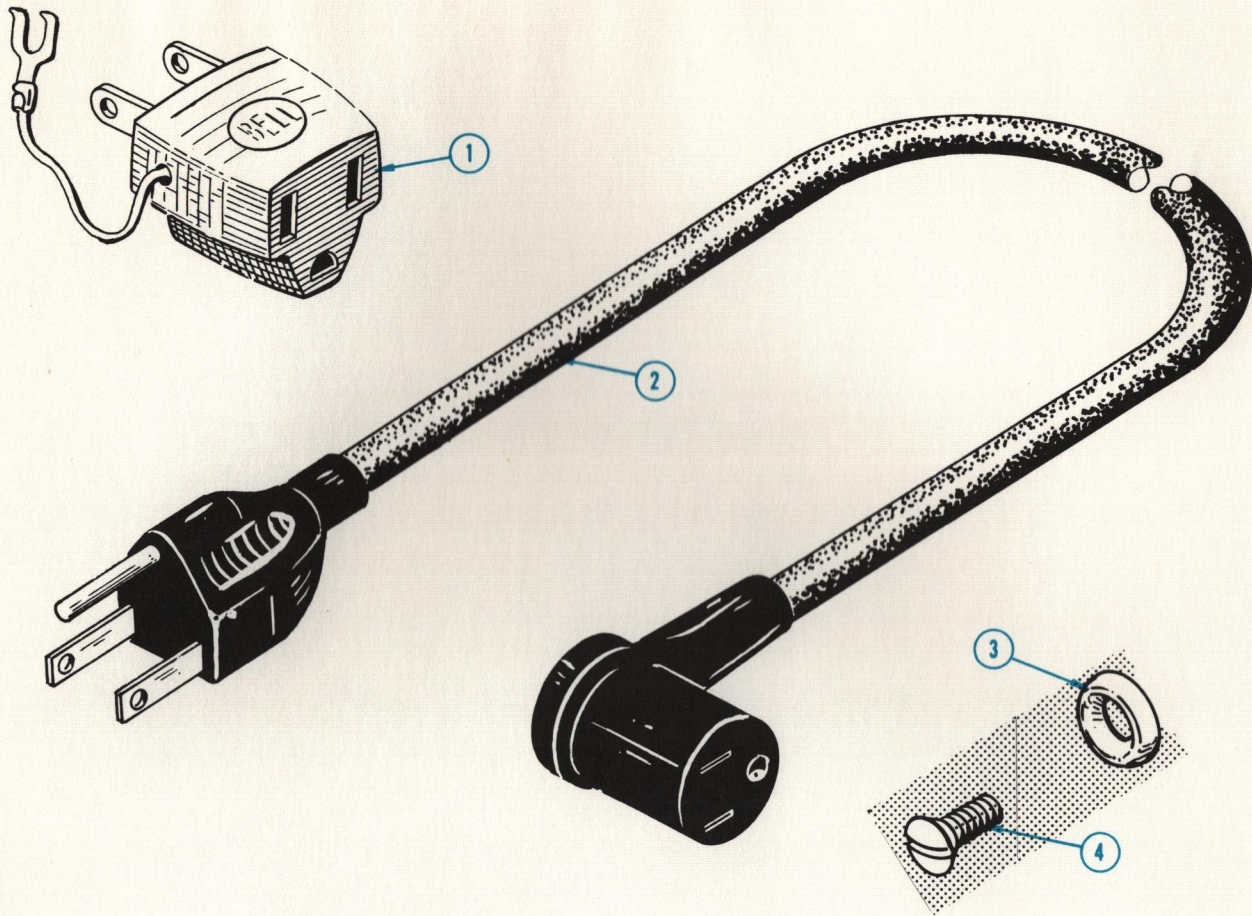

Fig. & Index No.	Tektronix Part No.	Serial/Model Eff	No. Disc	Qty	Q					Description
					1	2	3	4	5	
14-1	010-0125-00	101	4530X	1						PROBE PACKAGE, P6006
-2	012-0016-00			1						CABLE, interconnecting
-3	378-0509-00	101	3919	1						FILTER, light, green
	378-0550-00	3920		1						FILTER, light, smoke gray
-4	212-0019-00			2						SCREW, 8-32 x 3/8 inch, OHS
-5	210-0832-00			2						WASHER, finishing, #8
	070-0220-01			1						MANUAL, instruction (not shown)

(B/A)

FIG. 15 TYPE 126 STANDARD ACCESSORIES



A

+

Fig. & Index No.	Tektronix Part No.	Serial/Model No. Eff	No. Disc	Q † y						Description
					1	2	3	4	5	
15-1	103-0013-00	X241		1						ADAPTER, power cord, 3 to 2 wire
-2	161-0001-00	101	240	1						CORD, power, 2 conductor, 8 feet
	161-0010-00	241		1						CORD, power, 3 conductor, 8 feet
-3	210-0832-00			2						WASHER, finishing, #8
-4	212-0019-00			2						SCREW, 8-32 x 3/8 inch, OHS
	070-0220-01			1						MANUAL, instruction (not shown)

B(A)

## MANUAL CHANGE INFORMATION

At Tektronix, we continually strive to keep up with latest electronic developments by adding circuit and component improvements to our instruments as soon as they are developed and tested.

Sometimes, due to printing and shipping requirements, we can't get these changes immediately into printed manuals. Hence, your manual may contain new change information on following pages. If it does not, your manual is correct as printed.

TYPE 360

TEXT CORRECTION

Section 1

Specifications

Page 1-5

Frequency Response

right column, 4<sup>th</sup> line

CHANGE TO:

DC to 75 KC

TYPE 162

TEXT CORRECTION

Section 1 Specifications

Page 1-2 Paragraph 1, last line

CHANGE: to read:

from  $\geq +145$  volts to  $\leq +25$  volts

Page 1-3 Sawtooth Characteristics

CHANGE: to read:

AMPLITUDE, decreases linearly with time from  $\geq +145$  V to  $\leq +25$  V.

03/568