

TEKTRONIX®

7704A
OSCILLOSCOPE
SYSTEM
SERVICE

INSTRUCTION MANUAL

Tektronix, Inc.
P.O. Box 500
Beaverton, Oregon 97005

Serial Number

100685

070-1260-00

373



WARRANTY

All TEKTRONIX instruments are warranted against defective materials and workmanship for one year. Any questions with respect to the warranty should be taken up with your TEKTRONIX Field Engineer or representative.

All requests for repair and replacement parts should be directed to the TEKTRONIX Field Office or representative in your area. This will assure you the fastest possible service. Please include the instrument Type Number or Part Number and Serial Number with all requests for parts or service.

Specifications and price change privileges reserved.

Copyright © 1973 by Tektronix, Inc., Beaverton, Oregon.
Printed in the United States of America. All rights reserved.
Contents of this publication may not be reproduced in any form without permission of Tektronix, Inc.

U.S.A. and Foreign TEKTRONIX products covered by U.S. and foreign patents and/or patents pending.

TEKTRONIX is a registered trademark of Tektronix, Inc.

TABLE OF CONTENTS















	Page
TABLE OF CONTENTS	i
LIST OF ILLUSTRATIONS	iii
LIST OF TABLES	v
SECTION 1	
OPERATING INFORMATION	
PRELIMINARY INFORMATION	
Operating Voltage	1-1
CONTROLS AND CONNECTORS	1-1
SECTION 2	
CIRCUIT DESCRIPTION	
BLOCK DIAGRAM	
Block Diagram Description	2-1
CIRCUIT OPERATION	2-1
LOGIC FUNDAMENTALS	
Symbols	2-3
Logic Polarity	2-3
Input/Output Tables	2-3
Non-Digital Devices	2-3
CALIBRATOR AND FRONT PANEL 	2-6
MAIN INTERFACE 	2-7
LOGIC CIRCUIT 	2-9
TRIGGER SELECTOR 	2-25
VERTICAL INTERFACE 	2-28
HORIZONTAL INTERFACE 	2-30
OUTPUT SIGNALS 	2-31
INVERTER/RECTIFIERS 	2-33
LOW-VOLTAGE REGULATORS 	2-37
READOUT SYSTEM 	2-39
MAIN INTERCONNECT 	2-55
VERTICAL AMPLIFIER 	2-57
HORIZONTAL AMPLIFIER 	2-58
CRT CIRCUIT 	2-59
SECTION 3	
MAINTENANCE	
Panel Removal	3-1
Power-Unit Removal	3-1
PREVENTIVE MAINTENANCE	
Cleaning	3-2
Lubrication	3-2
Visual Inspection	3-2
Semiconductor Checks	3-2
Recalibration	3-2
TROUBLESHOOTING	
Troubleshooting Equipment	3-3
Troubleshooting Techniques	3-3

TABLE OF CONTENTS (cont)

	Page
Special Adjustment Procedures	3-5
CORRECTIVE MAINTENANCE	
Soldering Techniques	3-10
Component Replacement	3-10
Recalibration After Repair	3-19
Instrument Repackaging	3-19
SECTION 4	
CALIBRATION	
Calibration Interval	4-1
Tektronix Field Services	4-1
Using This Procedure	4-1
TEST EQUIPMENT REQUIRED	4-1
Special Calibration Fixtures	4-1
Calibration Equipment Alternatives	4-1
Signal Connections	4-2
CALIBRATION PROCEDURE	
Index to Calibration Procedure	4-3
Preliminary Procedure for Calibration	4-4
POWER SUPPLY	4-5
Z-AXIS AND DISPLAY	4-7
VERTICAL SYSTEM	4-10
TRIGGERING	4-14
HORIZONTAL SYSTEM	4-16
CALIBRATOR	4-19
OUTPUT SIGNALS	4-21
READOUT SYSTEM	4-23
SECTION 5	
ELECTRICAL PARTS LIST	
SECTION 6	
DIAGRAMS AND CIRCUIT BOARD ILLUSTRATIONS	
Symbols and Reference Designators	
SECTION 7	
MECHANICAL PARTS LIST	
CHANGE INFORMATION	

LIST OF ILLUSTRATIONS (cont)

Number		Page	Number		Page
2-44	Readout word relating 10 possible character locations to the decimal point instructions that can be encoded, and the resultant CRT display.	2-55	6-7	Electrode configuration for semiconductors shown on diagram 3.	6-7
2-45	Flow chart for character generation by the Readout System.	2-56	◇ 3	Logic Circuit	6-7
2-46	Vertical Amplifier circuit detailed block diagram.	2-57	6-8	A24—Trigger Selector circuit board.	6-8
2-47	Horizontal Amplifier circuit detailed block diagram.	2-58	◇ 4	Trigger Selector	6-9
2-48	Detailed block diagram of CRT Circuit.	2-60	6-9	A22—Vertical Interface circuit board (front view).	6-10
3-1	Power-unit securing screws.	3-1	6-10	A22—Vertical Interface circuit board (rear view).	6-10
3-2	Troubleshooting chart for 7704A.	3-6	◇ 5	Vertical Interface	6-11
3-3	Location of P4417 and P4418 on A44, Vertical Amplifier board.	3-8	6-11	A23—Horizontal Interface circuit board.	6-12
3-4	Location of adjustments on A22, Vertical Interface board.	3-9	◇ 6	Horizontal Interface	6-13
3-5	Location of P4315 and P4316 on A43, Horizontal Output board.	3-10	6-12	A33—Signal Out circuit board.	6-14
3-6	Location of adjustments on A23, Horizontal Interface board.	3-11	◇ 7	Output Signals	6-15
3-7	Disassembly and assembly of Display and Acquisition units.	3-12	6-13	A30—Power Supply Inverter circuit board.	6-16
3-8	Exploded-view drawing of a portion of the power unit identifying several critical parts.	3-15	6-14	A31—Rectifier and Filter circuit board.	6-16
4-1	Waveform showing correct high-frequency compensation of horizontal amplifier. Circle surrounds compensated portion of waveform.	4-18	6-15	Electrode configuration for semiconductors shown on diagram 8.	6-17
4-2	Typical display when checking X-Y phase shift.	4-18	◇ 8	Inverter/Rectifiers	6-17
4-3	Readout display with Q3416 removed.	4-23	6-16	A32—Regulator circuit board.	6-18
6-1	Electrode configuration for semiconductors used in the 7704A.	6-1	6-17	Electrode configuration for semiconductors shown on diagram 9.	6-19
6-2	Location of circuit boards in the 7704A.	6-1	◇ 9	Low-Voltage Regulators.	6-19
6-3	A10—Calibrator circuit board.	6-2	6-18	A34—Readout circuit board.	6-20
6-4	Electrode configuration for semiconductors shown on diagram 1.	6-3	6-19	Electrode configuration for semiconductors shown on diagram 10.	6-21
◇ 1	Calibrator and Front Panel	6-3	◇ 10	Readout System	6-21
6-5	A20—Main Interface circuit board.	6-4	◇ 11	Main Interconnect	6-23
◇ 2	Main Interface	6-5	6-20	A44—Vertical Amplifier circuit board.	6-24
6-6	A25—Logic circuit board.	6-6	◇ 12	Vertical Amplifier	6-25
			6-21	A43—Horizontal Output circuit board.	6-26
			6-22	Electrode configuration for semiconductors shown on diagram 13.	6-27
			◇ 13	Horizontal Amplifier	6-27
			6-23	A41—Z-Axis circuit board.	6-28
			6-24	A42—HV circuit board.	6-28

LIST OF ILLUSTRATIONS (cont)

Number	Page	Number	Page
6-25	Electrode configuration for semiconductors shown on diagram 14.	6-29	6-35
	CRT Circuit.	6-29	6-35
6-26	+54-Volt test point location on A32—Regulator board (top of power unit).	6-31	6-35
6-27	+54-Volt adjustment, R3143, location in power unit.	6-31	6-35
6-28	Power-supply test points and —50-Volt adjustment locations on A32—Regulator board.	6-31	
6-29	+150-Volt test point location on A43—Horizontal Output board.	6-31	
6-30	TP 4222, high-voltage test point location.	6-33	
6-31	Location of Z-Axis and Display calibration adjustments and test points on A41—Z-Axis board.	6-33	
6-32	Location of Vertical System calibration adjustments on A44—Vertical Amplifier board.	6-33	
6-33	Location of high-frequency compensation adjustments on A22—Vertical Interface board.	6-33	
6-34	Location of Horizontal System calibration adjustments on A43—Horizontal Output board.	6-35	
6-35	Location of Calibrator adjustments on A10—Calibrator board.	6-35	
6-36	Location of signal selector switches on A33—Output Signals board.	6-35	
6-37	Location of Readout System calibration adjustments on A34—Readout board.	6-35	

MECHANICAL PARTS LIST ILLUSTRATIONS

Number	
1	D7704
2	A7704 Front
3	A7704 Rear
4	Cabinet
5	Accessories
6	Instrument Options
7	Repackaging

LIST OF TABLES

Number	Page
2-1	Basic Logic Reference
2-2	Standard Readout Format
2-3	Channel Address Code
3-1	Power Supply Tolerance and Ripple
3-2	Fuse Ratings
4-1	Test Equipment
4-2	Power Supply Tolerance
4-3	High-Frequency Compensation

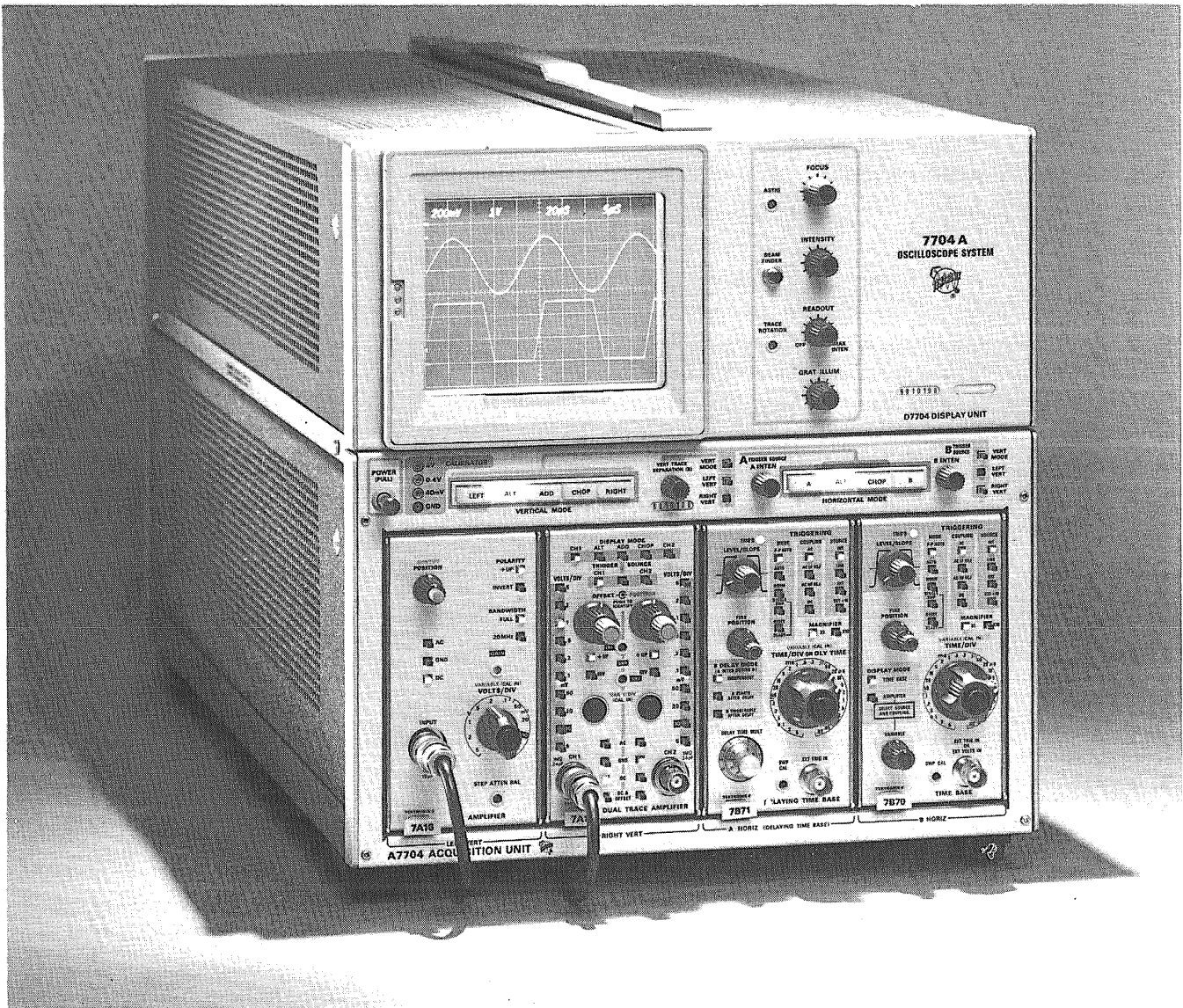

7704A Oscilloscope System.

INTRODUCTION

The TEKTRONIX 7704A Oscilloscope System is a solid-state, high performance instrument designed for general applications. (For rise time and bandwidth specifications of oscilloscope systems using the 7704A, see the Operators manual). The system is composed of two individual units, the A7704 Acquisition Unit and the D7704 Display Unit.

The A7704 Acquisition Unit has four plug-in compartments. The left pair of plug-in units is connected to the vertical system; the right pair is connected to the horizontal system. Electronic switching between the plug-ins connected to each system allows a dual-trace vertical display or a dual-sweep horizontal display.

The D7704 Display Unit features a CRT with small spot size and high writing rate. In addition to the waveform, the CRT can also display alpha-numeric information from the plug-in units, such as deflection factor, sweep rate and other encoded parameters. Standard graticule size is 8 X 10 centimeters.

DC supplies in the Acquisition Unit supply power for the entire instrument. These supplies are regulated to assure that performance is not affected by variations in line voltage and frequency, or by changes in load due to the varying power requirements of the plug-in units.

OPERATING INFORMATION

PRELIMINARY INFORMATION

Operating Voltage

The 7704A can be operated from either a 115-volt or a 230-volt nominal line voltage source. The Line Selector assembly on the rear panel converts this instrument from one operating voltage to the other. This assembly also includes line fuses. Use the following procedure to obtain correct instrument operation from the line voltage available.

CAUTION

This instrument is designed for operation from a power source with its neutral at or near earth (ground) potential with a separate safety-earth conductor. It is not intended for operation from two phases of a multi-phase system, or across the legs of a single-phase, three-wire system.

1. Disconnect the instrument from the power source.
2. Loosen the two captive screws which hold the cover onto the selector assembly; then pull to remove the cover.
3. To convert from 115-volt to 230-volt nominal line voltage, or vice versa, pull out the Selector switch bar (see Fig. 1-1) and plug it back into the remaining hole. Change the line-cord power plug to match the power-source receptacle, or use a 115- to 230-volt adapter.

Power Cord Conductor Identification

Conductor	Color	Alternate Color
Ungrounded (Line)	Brown	Black
Grounded (Neutral)	Blue	White
Grounding (Earthing)	Green-Yellow	Green-Yellow

4. Install the cover and tighten the captive screws.

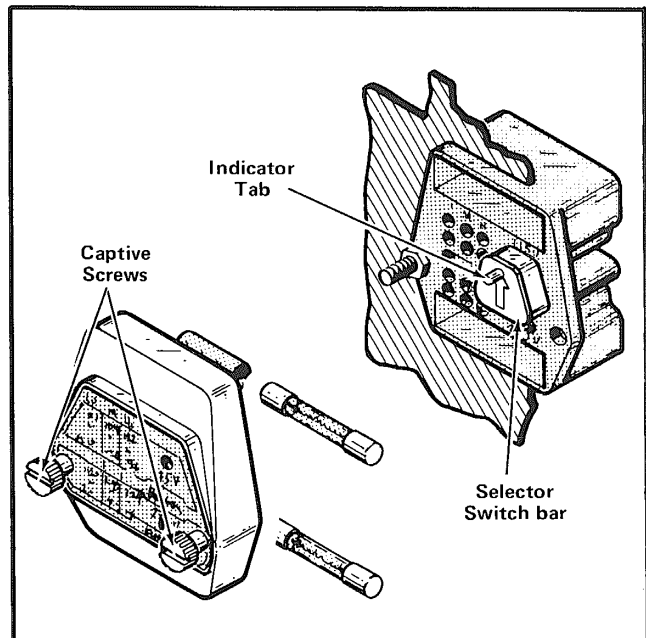

Fig. 1-1. Line Selector assembly on rear panel (shown with cover and fuses removed).

5. Before applying power to the instrument, check that the indicator tab on the switch bar is protruding through the correct hole for the desired line voltage range.

The 7704A is designed to be used with a three-wire AC power system. If the three- to two-wire adapter is used to connect this instrument to a two-wire AC power system, be sure to connect the ground lead of the adapter to earth (ground). Failure to complete the ground system may allow the chassis of this instrument to be elevated above ground potential and pose a shock hazard.

CONTROLS AND CONNECTORS

The major controls and connectors are located on the front panel of the instrument. Several auxiliary functions are provided on the rear panel. Figure 1-2 shows the front and rear panels and provides brief descriptions of each control and connector. For more detailed operating information, refer to the 7704A Operators Manual.

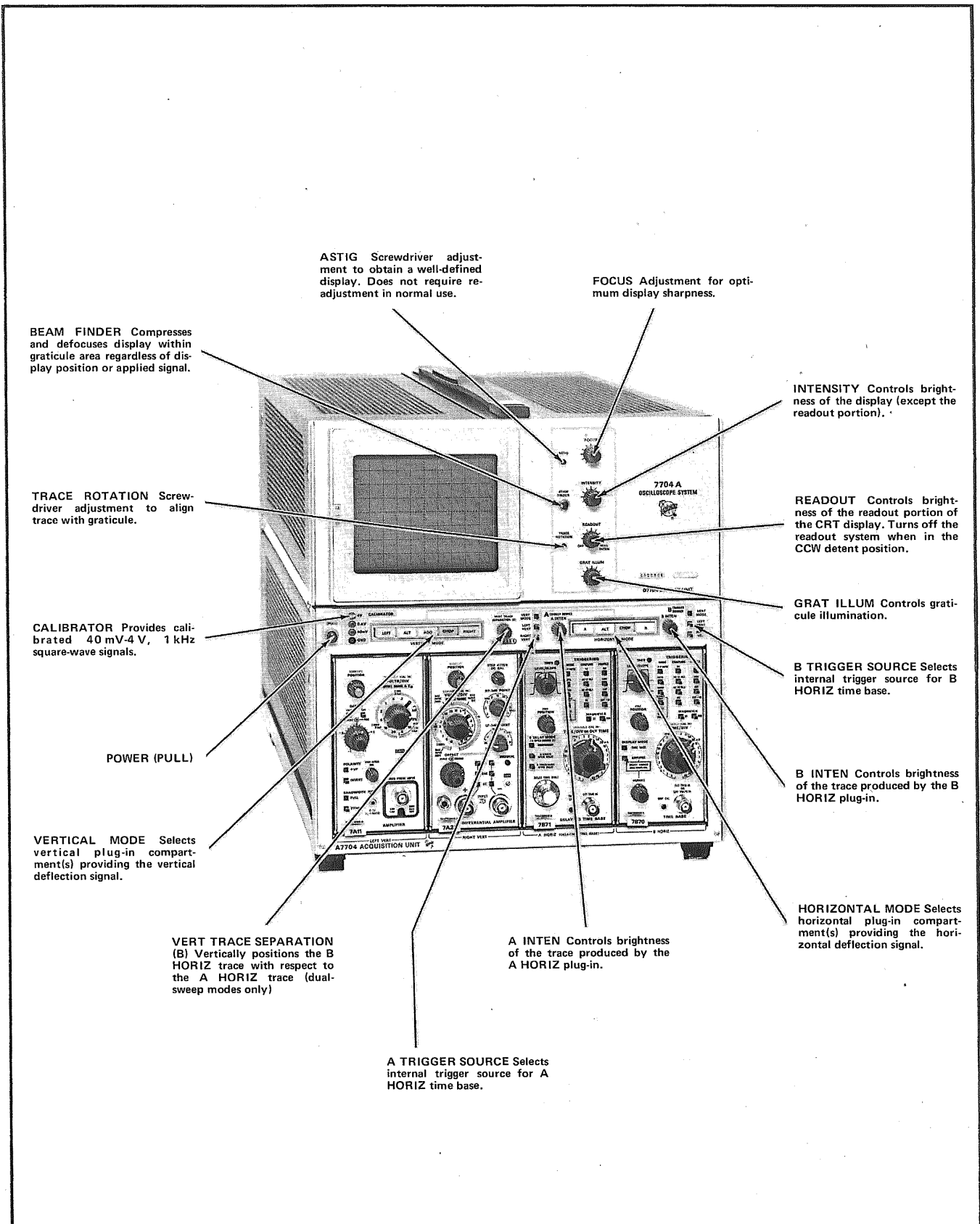

Fig. 1-2A. 7704A front-panel controls and connectors.

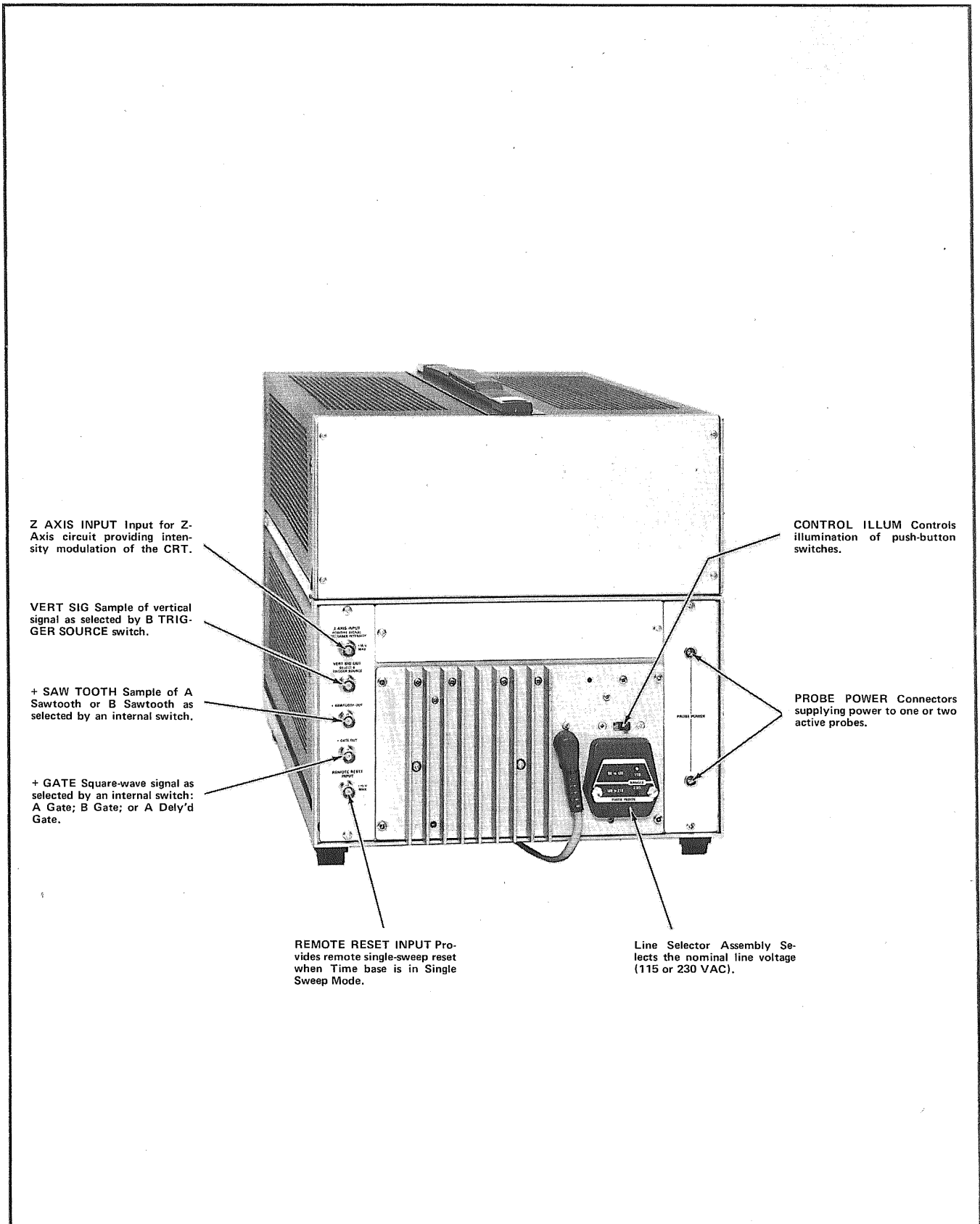

Fig. 1-2B. 7704A rear-panel controls and connectors.

CIRCUIT DESCRIPTION

This section of the manual describes the circuitry used in the 7704A Oscilloscope System. The description begins with a discussion of the instrument, using the basic block diagram shown on Fig. 2-1. Next, each circuit is described in detail, using detailed block diagrams when appropriate, to show the relationship between the stages in each major circuit. Detailed schematics of each circuit are located in the Diagrams section at the back of this manual; refer to these schematics throughout the following circuit description for specific electrical values and relationships.

BLOCK DIAGRAM

The basic block diagram in Fig. 2-1 shows the basic interconnections between the individual blocks; each block representing a major circuit within the instrument. The numbered diamond in each block refers to the circuit diagram (located at the rear of the manual) which covers that specific part of the instrument.

Block Diagram Description

Vertical signals from both vertical plug-in compartments are applied to the Vertical Interface circuit. This circuit determines whether the signal from the left or right vertical plug-in unit is displayed. The selected vertical signal is then amplified by the Vertical Amplifier circuit to drive the vertical deflection plates of the CRT. The Vertical Amplifier circuit also accepts the Y-Readout signal from the Readout System to produce the vertical portion of the alpha-numeric readout display.

The Readout System provides an alpha-numeric display for information encoded by the plug-in units. This display is presented on the CRT on a time-shared basis with the analog waveform display.

Horizontal signals from both horizontal plug-in compartments are connected to the Horizontal Interface circuit. This circuit determines whether the signal from the A or B horizontal unit is displayed. The selected signal is connected to the Horizontal Amplifier circuit, where it is amplified to provide the horizontal deflection for the CRT beam. The Horizontal Amplifier circuit also accepts the X-Readout signal from the Readout System to produce the horizontal portion of the readout display.

The Logic Circuit develops control signals for use in other circuits within the instrument and plug-in units. These control signals automatically determine the correct operation of the instrument in relation to the plug-in installed or selected, the plug-in control settings, and the 7704A control settings.

The internal trigger signals from the vertical plug-in are connected to the Trigger Selector circuits. These circuits select the trigger signals to be applied to the sweep circuits in the horizontal plug-in units. The B Trigger Selector also supplies the drive signal for the Vertical Signal Output.

In addition to the Vertical Signal Output mentioned above, the Output Signals circuit also provides a +Sawtooth Out signal derived from the A or B horizontal sweep signals, and +Gate Out and readout triggering signals derived from the A or B horizontal gate signals.

The Calibrator circuit produces a one-kilohertz square-wave output. This signal is available as a voltage at the front-panel CALIBRATOR connectors or as a current through the 40 milliampere current-loop adapter available as an optional accessory.

The Inverter/Rectifiers circuit provides the low-voltage power necessary for operation of the entire instrument. The high voltages needed for the CRT are supplied by the CRT Circuit. The CRT Circuit also contains the Z-Axis Amplifier which provides the drive signal to control the intensity level of the display.

CIRCUIT OPERATION

This section provides a detailed description of the electrical operation and relationship of the circuits in the 7704A. The theory of operation for circuits unique to this instrument is described in detail in this discussion. Circuits commonly used in the electronics industry are not described in detail. If more information is desired on these commonly used circuits, refer to the following textbooks (also see books under Logic Fundamentals):

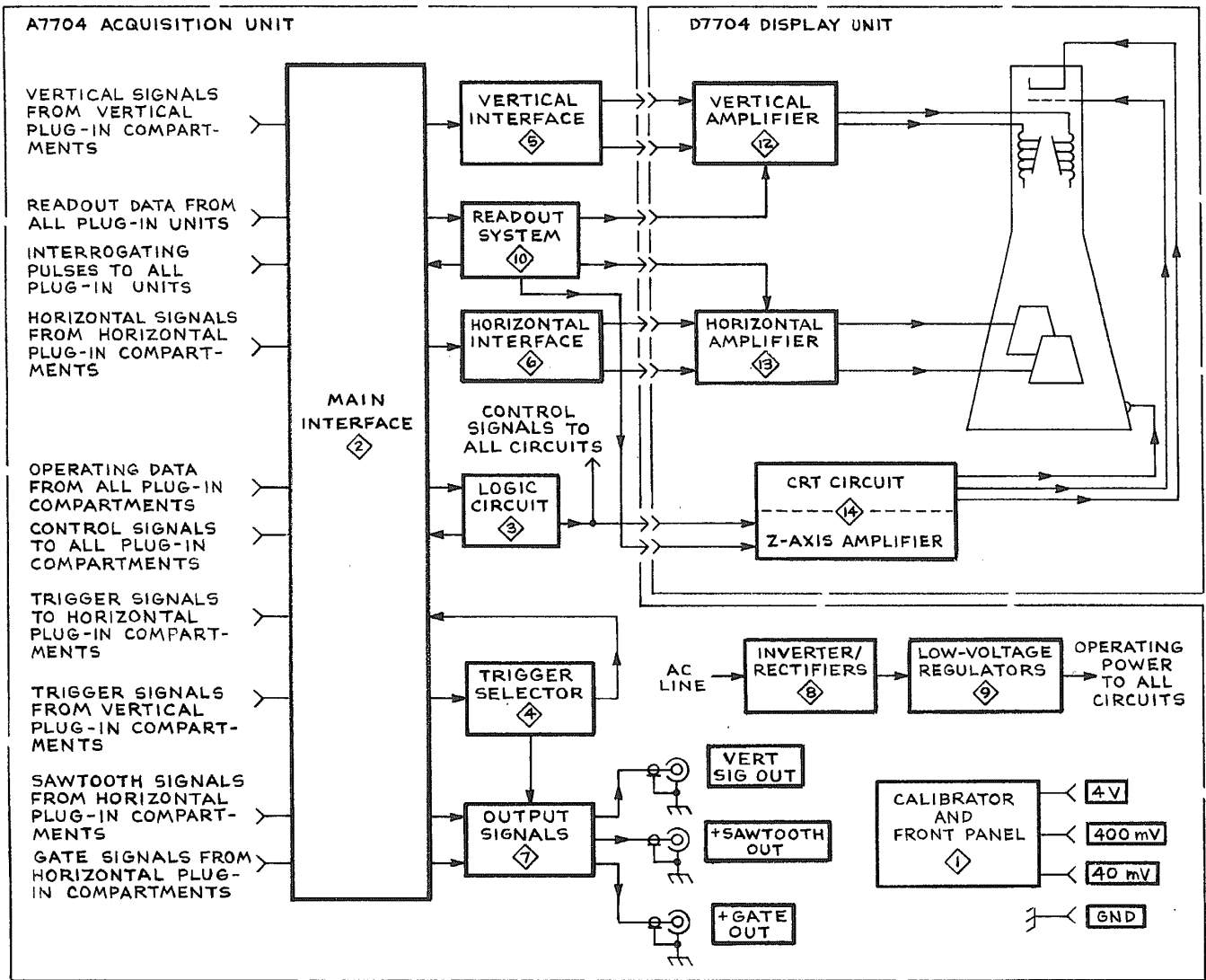

Fig. 2-1. 7704A block diagram.

Phillip Cutler, "Semiconductor Circuit Analysis", McGraw-Hill, New York, 1964.

Lloyd P. Hunter (Ed.), "Handbook of Semiconductor Electronics", second edition, McGraw-Hill, New York, 1962.

Jacob Millman and Herbert Taub, "Pulse, Digital, and Switching Waveforms", McGraw-Hill, New York, 1965.

The following circuit analysis is written around the detailed block diagrams which are given for each major circuit. These detailed block diagrams give the names of the individual stages within the major circuits and show how they are connected together to form the major circuit. The block diagrams also show the inputs and outputs for each circuit and the relationship of the front-panel controls to the individual stages. The circuit diagrams from which the detailed block diagrams are derived are shown in the Diagrams section.

NOTE

All references to direction of current in this manual are in terms of conventional current; i.e., from plus to minus.

LOGIC FUNDAMENTALS

Digital logic techniques are used to perform many functions within this instrument. The function and operation of the logic circuits are described using logic symbology and terminology. This portion of the manual is provided to aid in the understanding of these symbols and terms. The following information is a basic introduction to logic concepts, not a comprehensive discussion of the subject. For further information on binary number systems and the associated Boolean Algebra concepts, the derivation of logic functions, a more detailed analysis of digital logic, etc., refer to the following textbooks:

Robert C. Baron and Albert T. Piccirilli, "Digital Logic and Computer Operation", McGraw-Hill, New York, 1967.

Thomas C. Bartee, "Digital Computer Fundamentals", McGraw-Hill, New York, 1966.

Yaohan Chu, "Digital Computer Design Fundamentals", McGraw-Hill, New York, 1962.

Joseph Millman and Herbert Taub, "Pulse, Digital, and Switching Waveforms", McGraw-Hill, New York, Chapters 9-11, 1965.

Symbols

The operation of circuits in this instrument which use digital techniques is described using the graphic symbols set forth in military standard MIL-STD-806B. Table 2-1 provides a basic logic reference for the logic devices used within this instrument. Any deviations from the standard symbology, or devices not defined by the standard are described in the circuit description for the applicable device.

NOTE

Logic symbols used on the diagrams depict the logic function as used in this instrument and may differ from the manufacturer's data.

Logic Polarity

All logic functions are described using the positive logic convention. Positive logic is a system of notation where the more positive of two levels (HI) is called the true or 1-state; the more negative level (LO) is called the false or 0-state. The HI-LO method of notation is used in this logic description. The specific voltages which constitute a HI or LO state vary between individual devices.

NOTE

The HI-LO logic notation can be conveniently converted to 1-0 notation by disregarding the first letter of each step. Thus:

$$\begin{aligned} HI &= 1 \\ LO &= 0 \end{aligned}$$

Wherever possible, the input and output lines are named to indicate the function that they perform when at the HI (true) state. For example, the line labeled "V-H Inhibit" means that the vertical and horizontal deflection function is inhibited or disabled when this line is HI.

Input/Output Tables

Input/output (truth) tables are used in conjunction with the logic diagrams to show the input combinations important to a particular function, along with the resultant output conditions. This table may be given either for an individual device or for a complete logic stage. For examples of input/output tables for individual devices, see Table 2-1.

Non-Digital Devices

Not all of the integrated circuit devices in this instrument are digital logic devices. The function of non-digital devices is described individually, using operating waveforms or other techniques to illustrate their function.

TABLE 2-1

Basic Logic Reference

Device	Symbol	Description	Input/Output Table		
			Input		Output
			A	B	X
AND gate		A device with two or more inputs and one output. The output of the AND gate is HI if and only if all of the inputs are at the HI state.	LO	LO	LO
			LO	HI	LO
			HI	LO	LO
			HI	HI	HI

TABLE 2-1 (cont.)



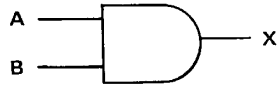

Device	Symbol	Description	Input/Output Table																																				
NAND gate		A device with two or more inputs and one output. The output of the NAND gate is LO if and only if all of the inputs are at the HI state.	<table border="1"> <thead> <tr> <th colspan="2">Input</th> <th>Output</th> </tr> <tr> <th>A</th> <th>B</th> <th>X</th> </tr> </thead> <tbody> <tr> <td>LO</td> <td>LO</td> <td>HI</td> </tr> <tr> <td>LO</td> <td>HI</td> <td>HI</td> </tr> <tr> <td>HI</td> <td>LO</td> <td>HI</td> </tr> <tr> <td>HI</td> <td>HI</td> <td>LO</td> </tr> </tbody> </table>	Input		Output	A	B	X	LO	LO	HI	LO	HI	HI	HI	LO	HI	HI	HI	LO																		
Input		Output																																					
A	B	X																																					
LO	LO	HI																																					
LO	HI	HI																																					
HI	LO	HI																																					
HI	HI	LO																																					
OR gate		A device with two or more inputs and one output. The output of the OR gate is HI if one or more of the inputs are at the HI state.	<table border="1"> <thead> <tr> <th colspan="2">Input</th> <th>Output</th> </tr> <tr> <th>A</th> <th>B</th> <th>X</th> </tr> </thead> <tbody> <tr> <td>LO</td> <td>LO</td> <td>LO</td> </tr> <tr> <td>LO</td> <td>HI</td> <td>HI</td> </tr> <tr> <td>HI</td> <td>LO</td> <td>HI</td> </tr> <tr> <td>HI</td> <td>HI</td> <td>HI</td> </tr> </tbody> </table>	Input		Output	A	B	X	LO	LO	LO	LO	HI	HI	HI	LO	HI	HI	HI	HI																		
Input		Output																																					
A	B	X																																					
LO	LO	LO																																					
LO	HI	HI																																					
HI	LO	HI																																					
HI	HI	HI																																					
NOR gate		A device with two or more inputs and one output. The output of the NOR gate is LO if one or more of the inputs are at the HI state.	<table border="1"> <thead> <tr> <th colspan="2">Input</th> <th>Output</th> </tr> <tr> <th>A</th> <th>B</th> <th>X</th> </tr> </thead> <tbody> <tr> <td>LO</td> <td>LO</td> <td>HI</td> </tr> <tr> <td>LO</td> <td>HI</td> <td>LO</td> </tr> <tr> <td>HI</td> <td>LO</td> <td>LO</td> </tr> <tr> <td>HI</td> <td>HI</td> <td>LO</td> </tr> </tbody> </table>	Input		Output	A	B	X	LO	LO	HI	LO	HI	LO	HI	LO	LO	HI	HI	LO																		
Input		Output																																					
A	B	X																																					
LO	LO	HI																																					
LO	HI	LO																																					
HI	LO	LO																																					
HI	HI	LO																																					
Inverter		A device with one input and one output. The output state is always opposite to the input state.	<table border="1"> <thead> <tr> <th>Input</th> <th>Output</th> </tr> <tr> <th>A</th> <th>X</th> </tr> </thead> <tbody> <tr> <td>LO</td> <td>HI</td> </tr> <tr> <td>HI</td> <td>LO</td> </tr> </tbody> </table>	Input	Output	A	X	LO	HI	HI	LO																												
Input	Output																																						
A	X																																						
LO	HI																																						
HI	LO																																						
LO-state indicator	  	<p>A small circle at the input or output of a symbol indicates that the LO state is the significant state. Absence of the circle indicates that the HI state is the significant state. Two examples follow:</p> <p>AND gate with LO-state indicator at the A input.</p> <p>The output of this gate is HI if and only if the A input is LO and the B input is HI.</p> <p>OR gate with LO-state indicator at the A input:</p> <p>The output of this gate is HI if either the A input is LO or the B input is HI.</p>	<table border="1"> <thead> <tr> <th colspan="2">Input</th> <th>Output</th> </tr> <tr> <th>A</th> <th>B</th> <th>X</th> </tr> </thead> <tbody> <tr> <td>LO</td> <td>LO</td> <td>LO</td> </tr> <tr> <td>LO</td> <td>HI</td> <td>HI</td> </tr> <tr> <td>HI</td> <td>LO</td> <td>LO</td> </tr> <tr> <td>HI</td> <td>HI</td> <td>LO</td> </tr> </tbody> </table> <table border="1"> <thead> <tr> <th colspan="2">Input</th> <th>Output</th> </tr> <tr> <th>A</th> <th>B</th> <th>X</th> </tr> </thead> <tbody> <tr> <td>LO</td> <td>LO</td> <td>HI</td> </tr> <tr> <td>LO</td> <td>HI</td> <td>HI</td> </tr> <tr> <td>HI</td> <td>LO</td> <td>LO</td> </tr> <tr> <td>HI</td> <td>HI</td> <td>HI</td> </tr> </tbody> </table>	Input		Output	A	B	X	LO	LO	LO	LO	HI	HI	HI	LO	LO	HI	HI	LO	Input		Output	A	B	X	LO	LO	HI	LO	HI	HI	HI	LO	LO	HI	HI	HI
Input		Output																																					
A	B	X																																					
LO	LO	LO																																					
LO	HI	HI																																					
HI	LO	LO																																					
HI	HI	LO																																					
Input		Output																																					
A	B	X																																					
LO	LO	HI																																					
LO	HI	HI																																					
HI	LO	LO																																					
HI	HI	HI																																					

TABLE 2-1 (cont.)

Device	Symbol	Description	Input/Output Table																								
Edge symbol		<p>Normally superimposed on an input line to a logic symbol. Indicates that this input (usually the trigger input of a flip-flop) responds to the indicated transition of the applied signal.</p>																									
Triggered (toggle) Flip-Flop		<p>A bistable device with one input and two outputs (either or both outputs may be used). When triggered, the outputs change from one stable state to the other stable state with each trigger. The outputs are complementary (i.e., when one output is HI the other is LO). The edge symbol on the trigger (T) input may be of either polarity depending on the device.</p>	<table border="1"> <thead> <tr> <th colspan="2">Input</th> <th colspan="2">Output</th> </tr> <tr> <th colspan="2">Condition before trigger pulse</th> <th colspan="2">Condition after trigger pulse</th> </tr> </thead> <tbody> <tr> <td>X</td> <td>X</td> <td>X</td> <td>X</td> </tr> <tr> <td>LO</td> <td>HI</td> <td>HI</td> <td>LO</td> </tr> <tr> <td>HI</td> <td>LO</td> <td>LO</td> <td>HI</td> </tr> </tbody> </table>	Input		Output		Condition before trigger pulse		Condition after trigger pulse		X	X	X	X	LO	HI	HI	LO	HI	LO	LO	HI				
Input		Output																									
Condition before trigger pulse		Condition after trigger pulse																									
X	X	X	X																								
LO	HI	HI	LO																								
HI	LO	LO	HI																								
Set-Clear (J-K) Flip-Flop		<p>A bistable device with two inputs and two outputs (either or both outputs may be used). The outputs change state in response to the states at the inputs. The outputs are complementary (i.e., when one output is HI the other is LO).</p>	<table border="1"> <thead> <tr> <th colspan="2">Input</th> <th colspan="2">Output</th> </tr> <tr> <th>A</th> <th>B</th> <th>X</th> <th>X</th> </tr> </thead> <tbody> <tr> <td>LO</td> <td>LO</td> <td colspan="2">No change</td> </tr> <tr> <td>LO</td> <td>HI</td> <td>LO</td> <td>HI</td> </tr> <tr> <td>HI</td> <td>LO</td> <td>HI</td> <td>LO</td> </tr> <tr> <td>HI</td> <td>HI</td> <td colspan="2">Changes state</td> </tr> </tbody> </table>	Input		Output		A	B	X	X	LO	LO	No change		LO	HI	LO	HI	HI	LO	HI	LO	HI	HI	Changes state	
Input		Output																									
A	B	X	X																								
LO	LO	No change																									
LO	HI	LO	HI																								
HI	LO	HI	LO																								
HI	HI	Changes state																									
D (data) Type Flip-Flop		<p>A bistable device with two inputs and two outputs (either or both outputs may be used). When triggered the state of the "1" output changes to the state at the data (D) input prior to the trigger. The outputs are complementary (i.e., when one output is HI the other is LO). The edge symbol on the trigger (T) input may be of either polarity, depending on the device.</p>	<table border="1"> <thead> <tr> <th>Input</th> <th colspan="2">Output</th> </tr> <tr> <th>A</th> <th>X</th> <th>X</th> </tr> </thead> <tbody> <tr> <td>LO</td> <td>LO</td> <td>HI</td> </tr> <tr> <td>HI</td> <td>HI</td> <td>LO</td> </tr> </tbody> </table> <p>Output conditions shown after trigger pulse</p>	Input	Output		A	X	X	LO	LO	HI	HI	HI	LO												
Input	Output																										
A	X	X																									
LO	LO	HI																									
HI	HI	LO																									

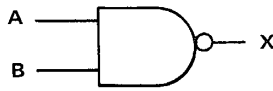
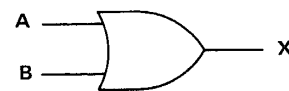
TABLE 2-1 (cont.)

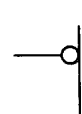
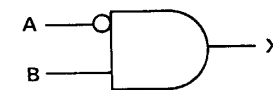
Device	Symbol	Description	Input/Output Table																												
Triggered Set-Clear (J-K) Flip-Flop		<p>A bistable device with three or more inputs and two outputs (either or both outputs may be used). When triggered, the outputs change state in response to the states at the inputs prior to the trigger. The outputs are complementary (i.e., when one output is HI the other is LO). The edge symbol on the trigger (T) input may be of either polarity depending on the device.</p>	<table border="1"> <thead> <tr> <th colspan="2">Input</th> <th colspan="2">Output</th> </tr> <tr> <th>A</th> <th>B</th> <th>X</th> <th>X</th> </tr> </thead> <tbody> <tr> <td>LO</td> <td>LO</td> <td colspan="2">No change</td> </tr> <tr> <td>LO</td> <td>HI</td> <td>LO</td> <td>HI</td> </tr> <tr> <td>HI</td> <td>LO</td> <td>HI</td> <td>LO</td> </tr> <tr> <td>HI</td> <td>HI</td> <td colspan="2">Changes state</td> </tr> </tbody> </table> <p>Output conditions shown after trigger pulse</p>	Input		Output		A	B	X	X	LO	LO	No change		LO	HI	LO	HI	HI	LO	HI	LO	HI	HI	Changes state					
Input		Output																													
A	B	X	X																												
LO	LO	No change																													
LO	HI	LO	HI																												
HI	LO	HI	LO																												
HI	HI	Changes state																													
Flip-Flop with Direct Inputs (may be applied to all triggered flip-flops)		<p>For devices with direct-set (S_D) or direct-clear (C_D) inputs, the indicated state at either of these inputs over-rides all other inputs (including trigger) to set the outputs to the states shown in the input/output table.</p>	<table border="1"> <thead> <tr> <th colspan="2">Input</th> <th colspan="2">Output</th> </tr> <tr> <th>A</th> <th>B</th> <th>X</th> <th>X</th> </tr> </thead> <tbody> <tr> <td>1</td> <td>1</td> <td colspan="2">No change¹</td> </tr> <tr> <td>Φ</td> <td>Φ</td> <td>LO</td> <td>HI</td> </tr> <tr> <td>Φ</td> <td>Φ</td> <td>HI</td> <td>LO</td> </tr> <tr> <td>Φ</td> <td>Φ</td> <td>HI</td> <td>HI</td> </tr> <tr> <td colspan="4">Undefined</td> </tr> </tbody> </table> <p>Φ = Has no effect in this case ¹Output state determined by conditions at triggered inputs</p>	Input		Output		A	B	X	X	1	1	No change ¹		Φ	Φ	LO	HI	Φ	Φ	HI	LO	Φ	Φ	HI	HI	Undefined			
Input		Output																													
A	B	X	X																												
1	1	No change ¹																													
Φ	Φ	LO	HI																												
Φ	Φ	HI	LO																												
Φ	Φ	HI	HI																												
Undefined																															

CALIBRATOR AND FRONT PANEL 1

Introduction

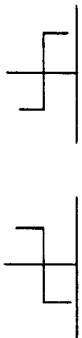
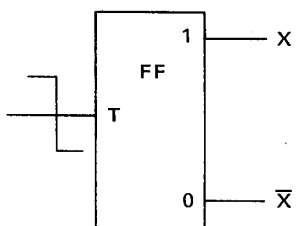
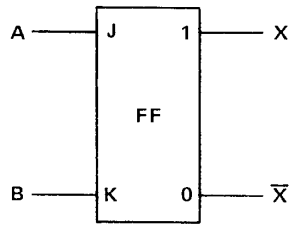
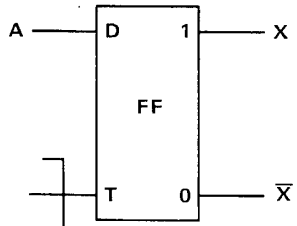
Diagram 1 shows the front-panel controls, the interconnections between these controls and the controlled circuits, and the Calibrator circuit. The circuitry associated with Q2080 and Q2090 is described in connection with the Trigger Selector circuit (diagram 4).

The Calibrator circuit provides a one-kilohertz square-wave signal at the front-panel CALIBRATOR pin-jacks. A block diagram of the Calibrator circuit is shown on Fig. 2-2.

2-kHz Oscillator

Q1001 and Q1003 are connected as a two-kilohertz, astable emitter-coupled multivibrator to provide the drive signal for the Calibrator Countdown stage. The repetition rate is determined by R1004, R1007, C1001, and the collector supply voltage for Q1001. The 1 kHz adjustment, R1001, sets the collector voltage of Q1001 so an accurate two-kilohertz square wave is produced at the collector of Q1003.

Calibrator Countdown

C1004 and R1009 differentiate the two-kilohertz signal from the collector of Q1003 to produce positive- and negative-going pulses coincident with the rise and fall of the

square wave. The negative-going pulses have no effect on Q1011. The positive-going pulses turn on Q1011 to produce negative-going pulses at its collector, which are of sufficient level and amplitude to drive the Clock input of U1010.

U1010 is a triggered set-clear (J-K) flip-flop connected as a triggered (toggle) flip-flop. The negative-going pulses from Q1011 trigger U1010 so that the outputs change state with each negative input pulse to provide a one-kilohertz output.

Output Amplifier

The one-kilohertz output of the Calibrator Countdown stage is connected through Q1021 and Q1023 to control the conduction of Q1025 and Q1027. Transistors Q1025 and Q1027 are connected as a comparator. The reference level at the base of Q1027 is determined by the network R1037-R1039-R1038-R1034-R1035-Q1031. The 0.4 Volts adjustment, R1037, is set to provide accurate output voltage at the 0.4 V Calibrator pin-jack. The voltage at the collector of Q1027 changes at a one-kilohertz repetition rate between zero volt and a level established by the reference level at its base.

Output Voltage Divider

The output voltage divider, made up of resistors R1043 through R1058, is designed to provide a low-impedance output for all ranges except 40 V, while providing accurate output voltages between four millivolts and 40 volts. (Four-millivolt and 40-volt outputs are available on internal circuit-board pins.)

The output resistance at the 40 V pin is about 15 kilohms, as determined by R1041 and the equivalent resistance of the divider network. The remaining output voltages are accurate with a one-megohm load or, at reduced output, a 50-ohm load.

Switch Logic

The VERTICAL MODE and HORIZONTAL MODE switches determine the operating mode of the Vertical Interface and Horizontal Interface circuits respectively. Each of these switches is self-canceling; i.e., only one button can be pressed at a time. Specific operation of these switches is described in connection with the circuits they control.

The A and B TRIGGER SOURCE switches control the operation of the Trigger Selector circuit. These switches are also self-canceling, so only one of the buttons can be pressed at a time. Operation of these switches is discussed in connection with the Trigger Selector circuit.

Indicator Lights

The indicator lights shown in connection with the mode switches indicate which mode has been selected. When one of the pushbuttons is pressed, it completes the circuit between the associated bulb and the +5-Volt Lights supply. A separate bulb is used for each mode switch pushbutton.

The A and B TRIGGER SOURCE switches are also illuminated to indicate the trigger source, but only one bulb is used for each switch assembly. Light guides are used, so that the button pressed receives light, but the remaining buttons are not illuminated. The power for the indicator lights is controlled by the rear-panel CONTROL ILLUM switch (shown on diagram 9).

MAIN INTERFACE 2

Diagram 2 shows the plug-in interface and the interconnections between the plug-in compartments, circuit boards, etc. of this instrument.

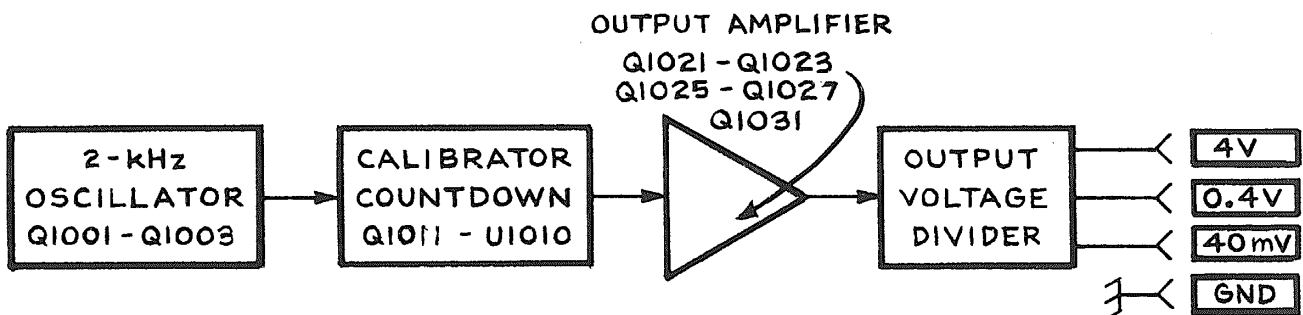

Fig. 2-2. Calibrator circuit detailed block diagram.

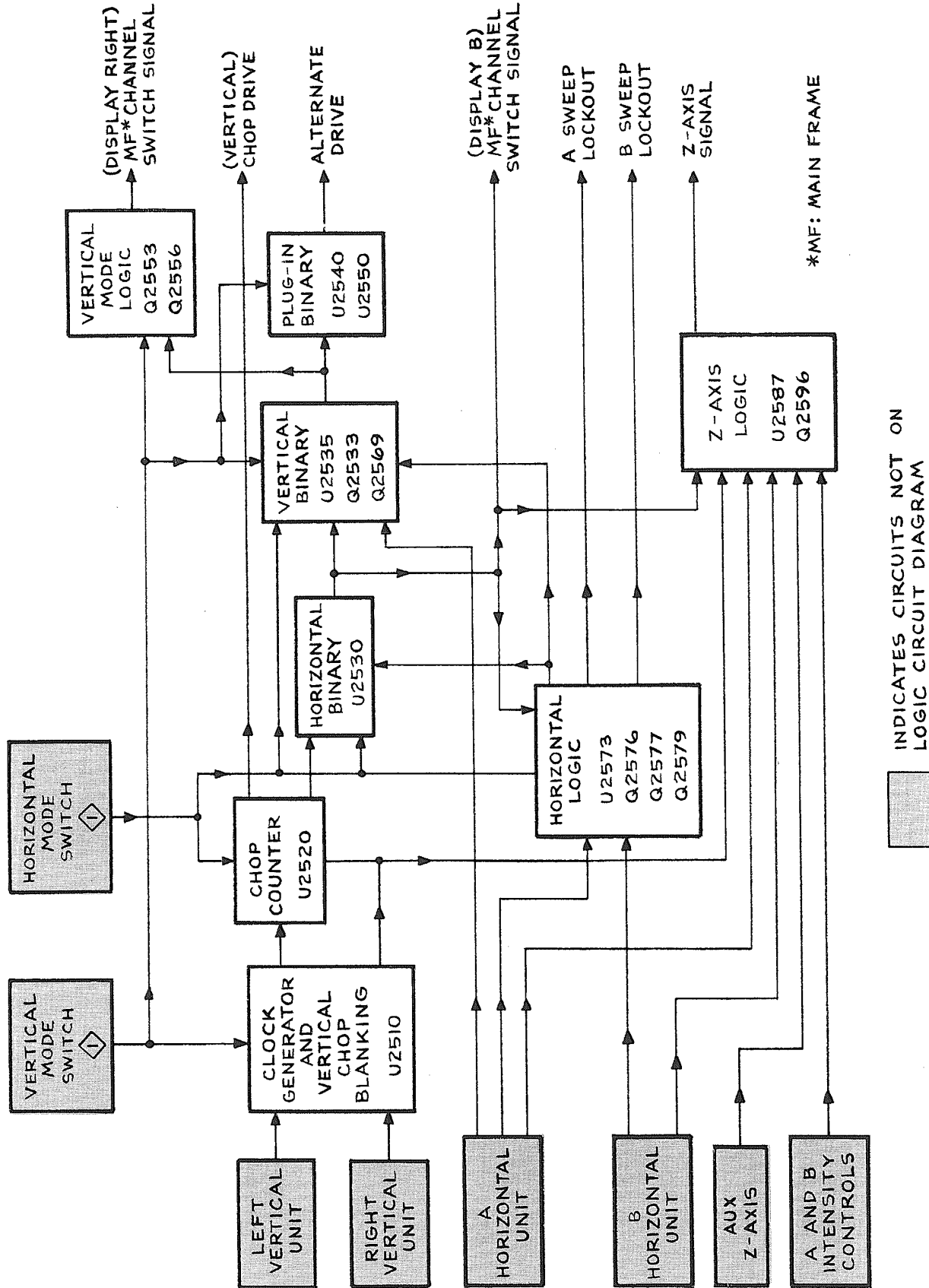

Fig. 2-3. Block diagram of Logic Circuit.

LOGIC CIRCUIT 3

General

The Logic Circuit develops control signals for use in other circuits within this instrument. These output signals automatically determine the correct instrument operation in relation to the plug-ins installed or selected, plug-in control settings, and 7704A control settings. A block diagram of the Logic Circuit is shown in Fig. 2-3. This diagram shows the source of the input control signals, the output signals produced by this stage, and the basic interconnections between blocks. The interconnections shown are intended only to indicate inter-relation between blocks and neither indicate a direct connection, nor that only a single connection is made between the given blocks. Details of the inter-relation between stages in this circuit are given in the circuit description which follows.

This circuit description for the Logic Circuit is written with the approach that each of the integrated circuits and its associated discrete components composes an individual stage as shown by the block diagram (Fig. 2-3). The operation of each of these stages is discussed, relating the

input signals or levels to the output, with consideration given to the various modes of operation that may affect the stage. A logic diagram is also provided for each stage. These diagrams are not discussed in detail, but are provided to aid in relating the function performed by a given stage to standard logic techniques. It should be noted that these logic diagrams are not an exact representation of the internal structure of the integrated circuit, but are only a logic diagram of the function performed by the stage. An input/output table is given, where applicable, for use along with the circuit description and logic diagram. These input/output tables document the combination of input conditions that are of importance to perform the prescribed function of an individual stage.

Horizontal Logic

The Horizontal Logic stage performs three separate logic functions: A Sweep Lockout, B Sweep Lockout, and Alternate Pulse Generator. Figure 2-4 identifies the three individual stages and the input and output terminals associated with each. Notice that some of the input signals are connected internally to more than one of the individual stages.

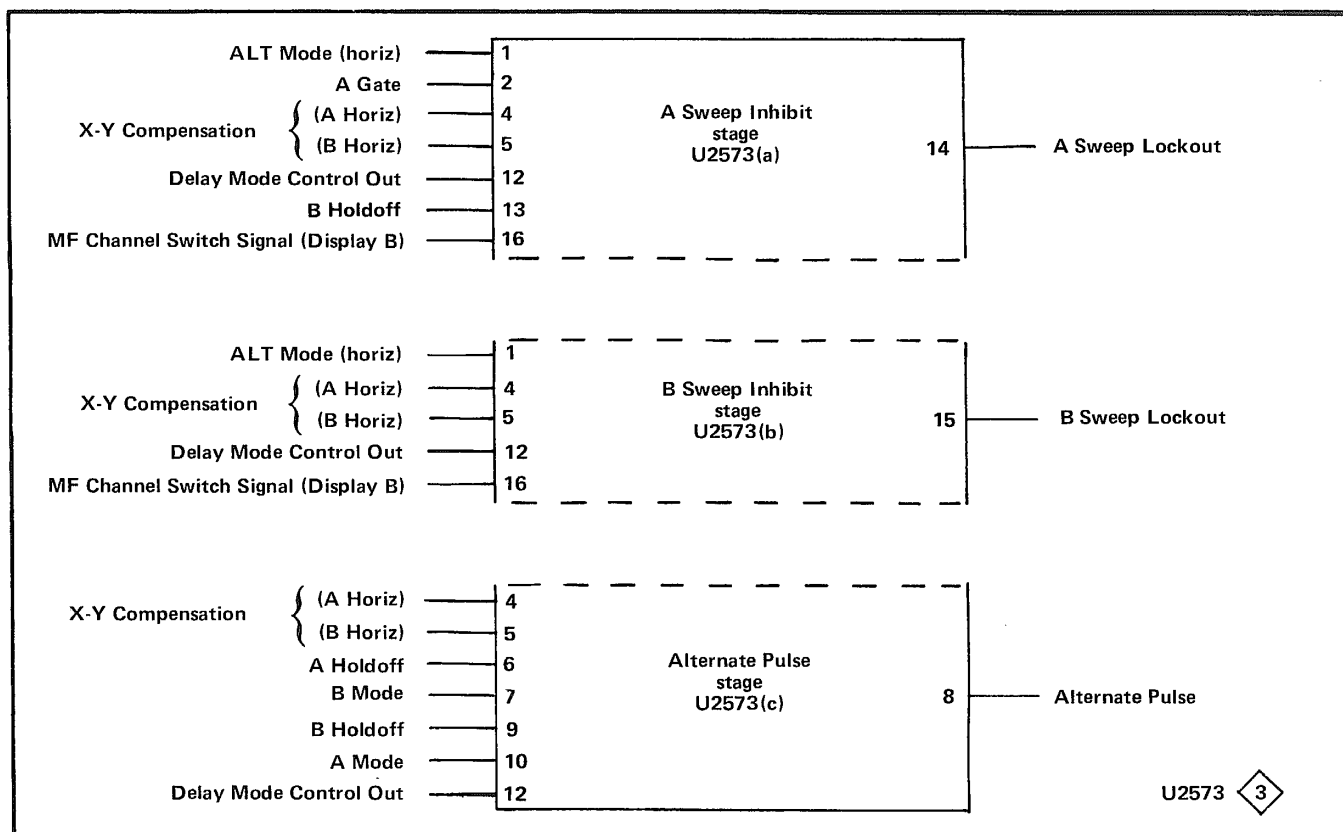

Fig. 2-4. Breakdown of separate stages within Horizontal Logic IC (U2573) showing inputs and outputs for each stage.

Circuit Description—7704A Service

A Sweep Lockout. The A Sweep Lockout stage produces an output level at the collector of Q2577 that determines if the A HORIZ time-base unit can produce a sweep. If this output is HI, the A HORIZ unit is locked out (disabled) so it cannot produce a sweep. If the level is LO, the A HORIZ unit is enabled and can produce a sweep when triggered.

The first combination disables the A sweep while the B sweep is being displayed in the ALT horizontal mode (both units must be in time-base mode) if non-delayed operation is being used. The second combination disables the A sweep during delayed-sweep operation so that the B sweep can complete its holdoff before the next A sweep begins.

As shown by the logic diagram and input/output table of Fig. 2-5, only two combinations of input conditions produce an A Sweep Lockout level (HI); if any one of the prescribed conditions is not met, the A Sweep Lockout level is LO and the A HORIZ time-base unit is enabled.

B Sweep Lockout. The B Sweep Lockout stage produces an output level at the collector of Q2579 that determines if the B HORIZ time-base unit can produce a sweep. A HI output level locks out (inhibits) the B HORIZ unit and a LO level enables the B HORIZ unit to produce a sweep.

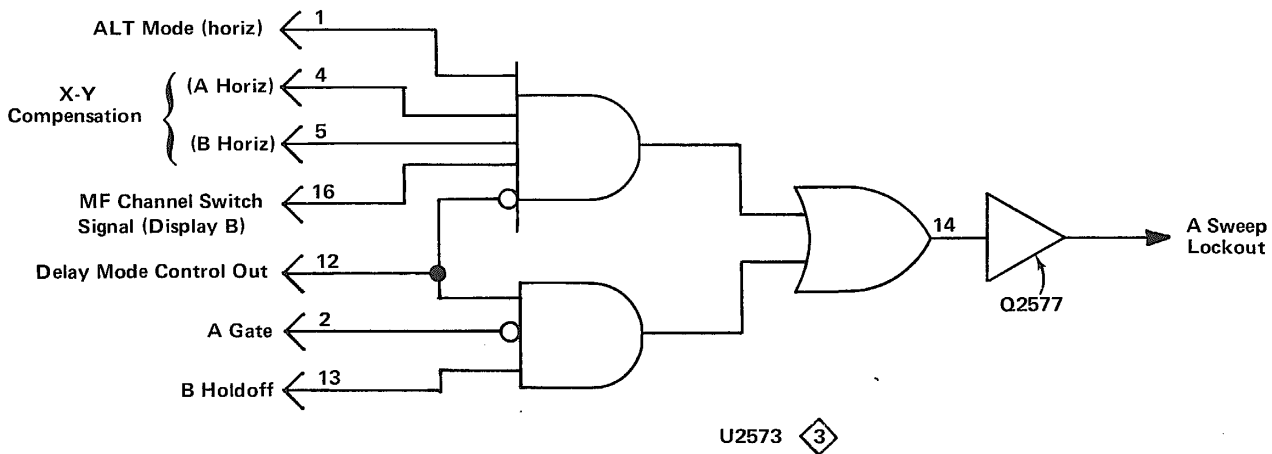

(A)

Input							Output
ALT Mode (horiz)	A Gate	X-Y Compensation		Delay Mode Control Out	B Holdoff	MF Channel Switch Signal (Display B)	A Sweep Lockout
1	2	A Horiz	B Horiz	12	13	16	
HI	Φ	HI	HI	LO	Φ	HI	HI
Φ	LO	Φ	Φ	HI	HI	Φ	HI
All other combinations							LO

Φ = Has no effect in this case.

Fig. 2-5. (A) Logic diagram for A Sweep Lockout stage; (B) Table of input/output combinations.

As shown by Fig. 2-6B, the output of this stage is HI only under one set of input conditions. This set of conditions disables the B sweep while the A sweep is being displayed in the ALT horizontal mode if both units are in a time-base mode and non-delayed sweep is used. For any other combination of input conditions, the B Sweep Lockout level is LO. However, the lockout level to the B time-base unit is determined by both the Delay Gate from the A time-base unit and the B Sweep Lockout level produced by this stage. The B sweep is enabled only when both of these levels are LO.

Figure 2-6A shows the logic diagram of the B Sweep Lockout stage. The gate connected to the output of this stage is a phantom-OR gate located on the Main Interface diagram (a phantom-OR gate performs the OR-logic function merely by interconnection of the two signal lines).

Alternate Pulse Generator. The third function performed by the Horizontal Logic stage is to produce an Alternate Pulse signal for use by the Horizontal and Vertical Binary stages. The Alternate Pulse is produced at the end of either sweep, depending upon the operating conditions as shown in Fig. 2-7B. The holdoff gate produced at the end of the sweep by the respective time-base unit is differentiated by either C2575 or C2573 to provide a positive-going pulse to pin 6 or 9.

In Fig. 2-7A, note the resistors shown connected to pins 6 and 9. These resistors, which are internal to the IC, hold the levels at pins 6 and 9 LO unless a HI level is applied to the corresponding input. Since the holdoff gate is capacitively-coupled to pins 6 and 9, these inputs are at the LO level except when a differentiated A or B Holdoff gate is received.

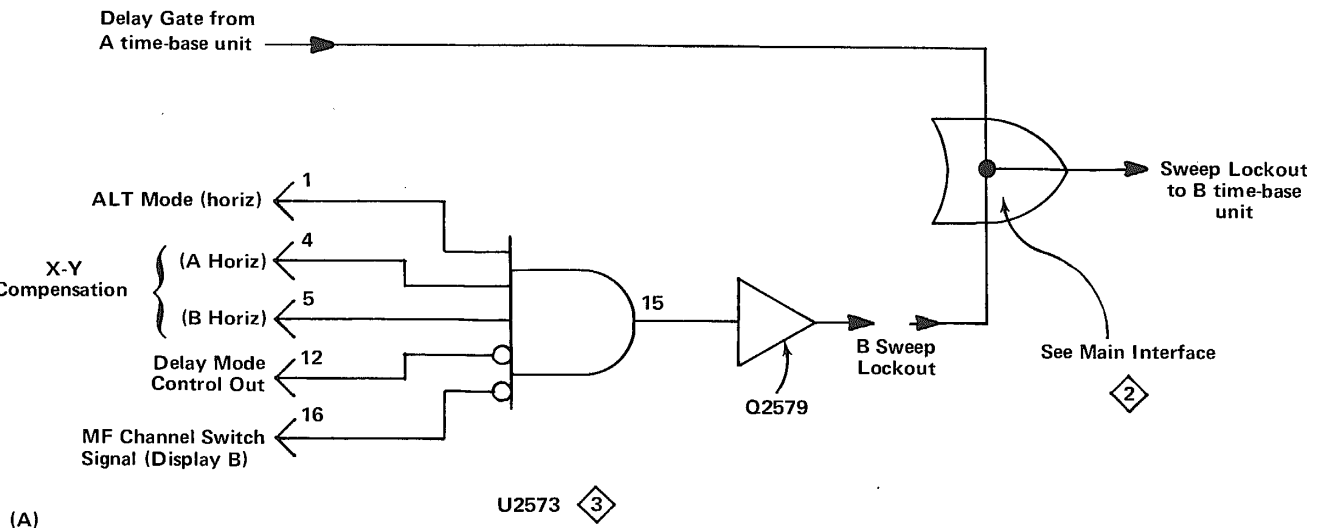

(A)

Input					Output
ALT Mode (horiz)	X-Y Compensation		Delay Mode Control Out	MF Channel Switch Signal (Display B)	B Sweep Lockout
1	4	5	12	16	
HI	HI	HI	LO	LO	HI
All other combinations					LO

(B)

Φ = Has no effect in this case

Fig. 2-6. (A) Logic diagram for B Sweep Lockout stage; (B) Table of input/output combinations.

Ⓐ

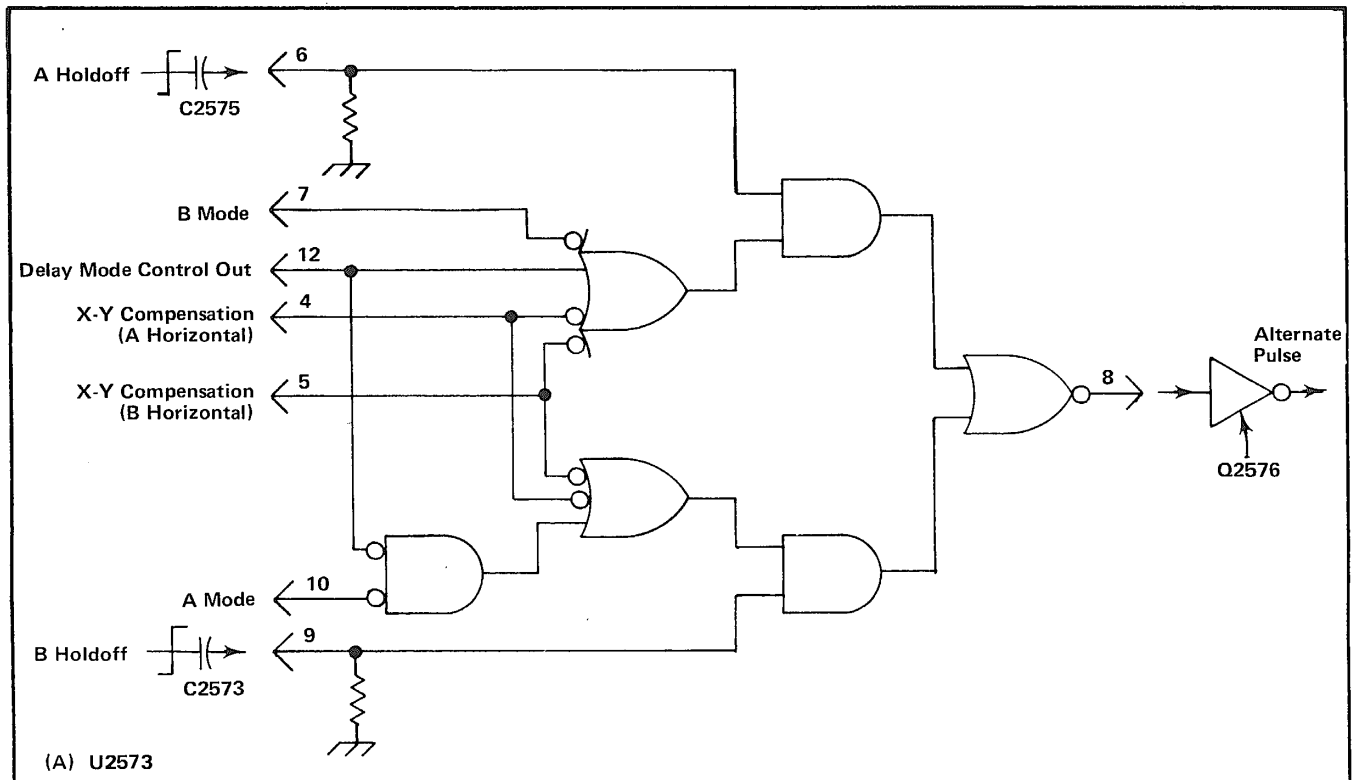

(A) U2573

Input							Output	
X-Y Compensation (A Horizontal) 4	X-Y Compensation (B Horizontal) 5	A Holdoff 6	B Mode 7	B Holdoff 9	A Mode 10	Delay Mode Control Out 12	Time-Base which is source of Alternate Pulse 8 ²	Horizontal Conditions
HI	Φ	HI ¹	LO	Φ	HI	Φ		A
Φ	HI	Φ	HI	HI ¹	LO	LO	B	B only
HI	HI	HI ¹	LO	HI ¹	LO	LO	A and B	ALT or CHOP
HI	HI	HI ¹	Φ	Φ	Φ	HI	A	A delays B
HI	LO	HI ¹	LO	LO	Φ	Φ	A	A with amplifier unit in B compartment.
LO	HI	LO	Φ	HI ¹	LO	LO	B	B with amplifier unit in A compartment.
All other combinations							No output pulse (LO at output)	

Φ = Has no effect in this case

¹ Positive-going pulse. Where both A and B Holdoff are required to be HI, a HI at either input produces an Alternate Pulse.

² Negative-going pulse.

(B)

Fig. 2-7. (A) Logic diagram for Alternate Pulse Generator stage; (B) Table of input/output combinations.

The following discussions describe the operation of the Alternate Pulse Generator stage in relation to the various combinations of input conditions shown in Fig. 2-7B.

1. A (ONLY) MODE

An Alternate Pulse is produced at the end of each A sweep when the HORIZONTAL MODE switch is set to the A position.

2. B (ONLY) MODE

In the B position of the HORIZONTAL MODE switch, an Alternate Pulse is produced at the end of each B sweep (A time-base must be in independent, non-delayed mode).

3. ALT OR CHOP MODE

When the HORIZONTAL MODE switch is set to ALT or CHOP (A time-base unit must be in independent, non-delayed mode), an Alternate Pulse is produced at the end of each sweep. For example, an Alternate Pulse is produced at the end of the A sweep, then at the end of the B sweep, again at the end of the A sweep, etc. Although Alternate Pulses are produced in the CHOP horizontal mode, they are not used in this instrument.

4. DELAYED SWEEP (A DELAYS B)

When the A time-base unit is set for delayed operation, the operation of the Alternate Pulse Generator is changed so an Alternate Pulse is produced only at the end of the A sweep, even when the HORIZONTAL MODE switch is set to B. This is necessary since the A time-base establishes the amount of delay time for the B time-base unit whenever it is displayed.

5. AMPLIFIER UNIT IN HORIZONTAL COMPARTMENT

When an amplifier unit is installed in either of the horizontal plug-in compartments, the Alternate Pulse can be produced only from the remaining time-base unit. If amplifier units are installed in both horizontal compartments, an Alternate Pulse is not produced since there are no time-base units to produce a holdoff pulse.

Z-Axis Logic

The Z-Axis Logic stage produces an output current which sets the intensity of the display on the CRT. The level of this output current is determined by the setting of the A or B INTENSITY controls, by a current added to provide an intensified zone on the A sweep for delayed-sweep operation, or by an external signal. The input current from the A and B INTENSITY controls is switched so that the output current matches the horizontal

display. The Chopped Blanking signals are applied to this stage to block the output current and blank the CRT display for vertical and horizontal chopping.

Figure 2-8 identifies the inputs to the Z-Axis Logic IC, U2587. This IC (integrated circuit) is current-driven at all inputs except pins 5 and 15. The current at pins 1, 2, 9, and 16 is variable from zero to four milliamperes and is determined by the applicable current source to control the output current at pin 8.

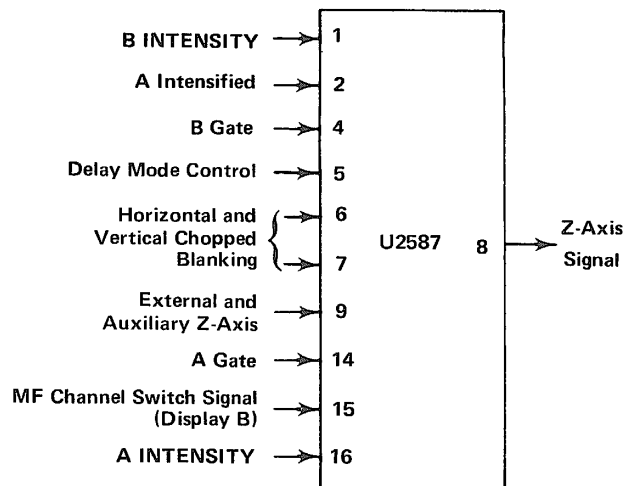
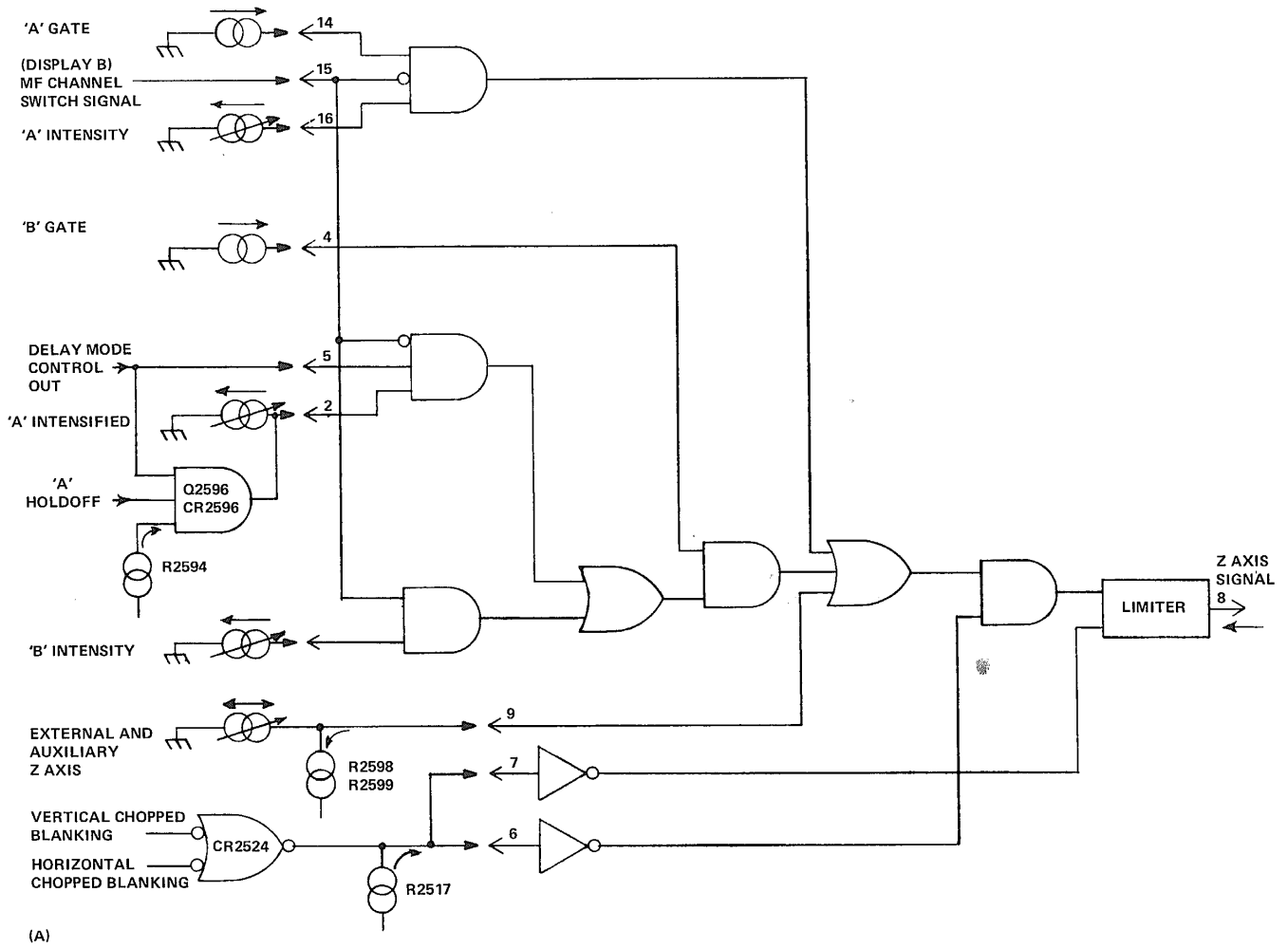

Fig. 2-8. Input and output pins for Z-Axis Logic IC.

The Chopped Blanking signal connected to pins 6 and 7 enables or disables this stage to control all output current. Quiescently, the level at pins 6 and 7 is HI so that the intensity current from pins 1, 2, 9, and 16 can pass to the output. However, pins 6 and 7 go LO during Vertical Chopped Blanking or Horizontal Chopped Blanking. This blocks the output current and the CRT is blanked. The Vertical Chopped Blanking signal is connected directly to U2587 from pin 4 of U2510. The Horizontal Chopped Blanking is connected to U2587 from pin 4 of U2520 through LR2523 and CR2524. CR2524 is normally reverse biased. When the Horizontal Chopped Blanking level goes LO, CR2524 is forward biased to produce a corresponding LO level at pins 6 and 7 of U2573.

The A INTENSITY control sets the output current level when the A Gate at pin 14 is HI and the MF (Main Frame) Channel Switch Signal at pin 15 is LO. The A INTENSITY current is blocked whenever the A Gate level goes LO (indicating that the A sweep is complete), or the MF Channel Switch Signal goes HI (indicating that the B sweep is being displayed). The current from the A INTENSITY control (see diagram 1) is connected to pin 16 through R2587.

Circuit Description—7704A Service



(A)

(B)

Input											Output
A Holdoff	1 ¹ B INTENSITY	2 ¹ A Intensified	4 B Gate	5 Delay Mode Control Out	6 Vertical or Horizontal Chopped Blanking Inhibit	9 ¹ External and Auxiliary Z Axis	14 A Gate	15 MF Channel Switch Signal	16 ¹ A INTENSITY	8 ¹ Z-Axis Signal	Current source controlling Z-Axis Signal
Φ	Φ	Φ	Φ	LO	HI	Φ ²	HI	LO	HI	HI	A INTENSITY
Φ	HI	Φ	HI	Φ	HI	Φ ²	Φ	HI	Φ	HI	B INTENSITY
LO	Φ	HI	HI	HI	HI	Φ ²	HI	LO	HI	HI	A INTENSITY and A Intensified
Φ	Φ	Φ	Φ	Φ	HI	HI	Φ	Φ	Φ	HI	External signal
All other combinations										LO	No output signal

LO = Minimum voltage or current.

HI = Maximum voltage or current.

Φ = Has no effect in this case

¹ Current level. LO = 0 mA

HI = Variable from 0 to 4 mA

² Current can be added or subtracted for intensity modulation.

Fig. 2-9. (A) Logic diagram for Z-Axis Logic stage; (B) Table of input/output combinations.

In the delayed mode, current is added to the A INTENSITY current during the A sweep time to intensify a portion of the trace. This intensified portion is coincident with the B-sweep time to provide an indication of the portion of the A sweep that is displayed in the delayed mode. The A Intensified current is supplied to pin 2 of U2587 from the A INTENSITY control through R2586. With this configuration, the intensified current increases as the A INTENSITY control setting is advanced to provide a proportional intensity increase in the intensified zone as the overall A-sweep intensity increases. Therefore, the intensified zone is more readily visible at high intensity levels. The intensified current is added to the A INTENSITY current to produce an intensified zone on the A sweep under the following conditions: HI A Gate level at pin 14, LO MF Channel Switch Signal at pin 15, HI B Gate level at pin 4, HI Delay Mode Control Out level at pin 5 and the base of Q2596, and LO A Holdoff level at the emitter of Q2596.

The B INTENSITY control determines the output current when the B Gate level at pin 4 and the MF Channel Switch Signal at pin 15 are both HI. The current from the B INTENSITY control (see diagram 1) is connected to the Z-Axis Logic stage through R2588.

The current level established by the intensity controls can be altered by the External and Auxiliary Z-Axis current level at pin 9. The current at this pin can come from the Z AXIS INPUT connector on the rear panel through R2092 or from any of the plug-in compartments through R2090, R2080, R2012, or R2010 (see diagram 2). This current either increases or decreases (depending on polarity) the output current to modulate the intensity of the display. Input from the Z AXIS INPUT connector allows the trace to be modulated by external signals. The auxiliary Z-Axis inputs from the plug-in compartments allow special purpose plug-in units to modulate the display intensity. Diodes CR2585 and CR2594 limit the maximum voltage change at pin 9 to about + and -0.6 volt to protect the Z-Axis Logic stage if an excessive voltage is applied to the Z AXIS INPUT connector.

Figure 2-9A shows a logic diagram of the Z-Axis Logic stage. Notice the current-driven inputs as indicated by the current-generator symbols at the associated inputs. An input/output table for the Z-Axis Logic stage is given in Fig. 2-9B.

Horizontal Binary

The MF (Main Frame) Channel Switch Signal (Display B) produced by the Horizontal Binary stage determines which horizontal unit provides the sweep display on the CRT. When this level is HI, the B HORIZ unit is displayed; when it is LO, the A HORIZ unit is displayed.

The MF Channel Switch Signal (Display B) is used in the following stages within the Logic Circuit: Horizontal Logic (for A and B Sweep Lockout), Z-Axis Logic (for blanking), and Vertical Binary (to synchronize vertical alternate switching with horizontal alternate switching). In addition, this signal is connected to the following circuits elsewhere in the instrument: Main Interface (to indicate which horizontal unit is to be displayed), Vertical Interface (for trace separation), and Horizontal Interface (for horizontal channel selection).

Notice that the levels at pins 3, 4, 7, and 10 are determined by the HORIZONTAL MODE switch (see diagram 1). This switch determines which horizontal mode has been selected by providing a HI level to only one of four output lines (the remaining lines are LO). Therefore, at any one time, either pin 3, pins 4 and 7 (notice that pins 4 and 7 are tied together), or pin 10 can be HI and the two unselected lines from the HORIZONTAL MODE switch remain LO.

The Horizontal Binary stage operates as follows for each position of the HORIZONTAL MODE switch (refer to Fig. 2-10B for input/output conditions):

1. A MODE

When the HORIZONTAL MODE switch is set to A, the MF Channel Switch Signal (Display B) is LO to indicate to all circuits that the A HORIZ unit is to be displayed.

2. B MODE

Selecting the B horizontal mode provides a HI MF Channel Switch Signal (Display B) to all circuits.

3. CHOP MODE

In the CHOP position of the HORIZONTAL MODE switch, the MF Channel Switch Signal (Display B) switches between the HI and LO levels to produce a display that switches between the A HORIZ and B HORIZ units at a 200-kHz or 20-kHz rate, as selected by S2510. The repetition rate of the MF Channel Switch Signal (Display B) in this mode is determined by the Horizontal Chopped Blanking pulse (see Chop Counter description). Each time the Horizontal Chopped Blanking pulse at pin 1 drops LO, the output at pin 6 switches to the opposite state.

4. ALT MODE

For ALT horizontal operation, the MF Channel Switch Signal (Display B) switches to the opposite state each time the negative portion of the Alternate Pulse is received from the Horizontal Logic stage. Repetition rate of the MF Channel Switch Signal (Display B) in this mode is one-half the repetition rate of the Alternate Pulse applied to pin 8.

Figure 2-10A shows a logic diagram of the Horizontal Binary stage. An input/output table showing the conditions for each position of the HORIZONTAL MODE switch is shown in Fig. 2-10B.

Vertical Binary

The Vertical Binary stage produces the Display Right Command to determine which vertical unit is to be displayed on the CRT. When this output level is HI, the

RIGHT VERT unit is displayed and when it is LO, the LEFT VERT unit is displayed. In the ALT or CHOP positions of the HORIZONTAL MODE switch (non-delayed operation only), the output of this stage is slaved to the output of the Horizontal Binary stage so that the Display Right Command is always HI when the MF (Main Frame) Channel Switch Signal (Display B) is LO, and vice versa. This action allows sweep-slaving operation in the ALT position of the VERTICAL MODE switch and the ALT or CHOP positions of the HORIZONTAL MODE

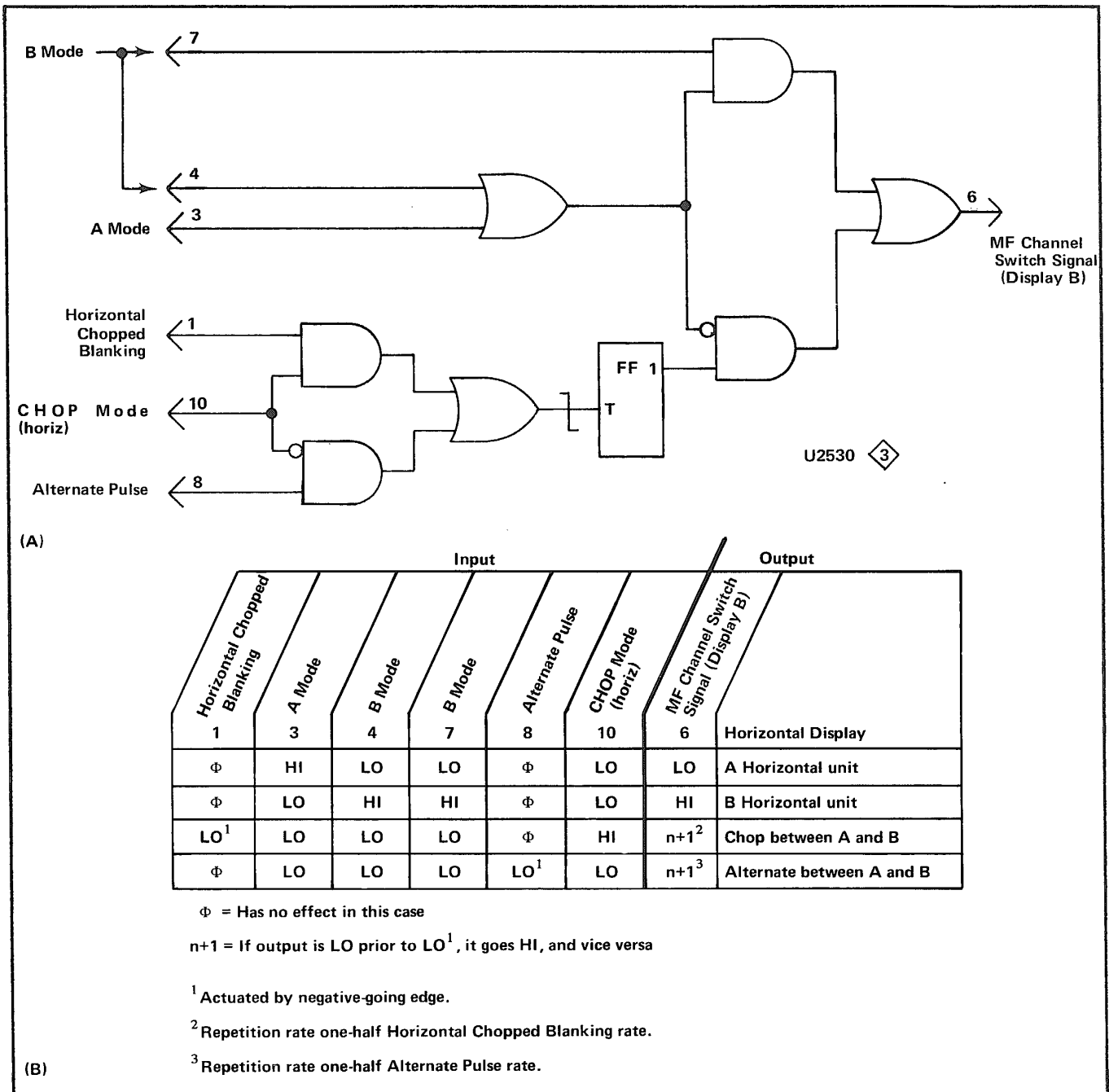

Fig. 2-10. (A) Logic diagram for Horizontal Binary stage; (B) Table of input/output combinations.

switch, whereby the LEFT VERT unit is always displayed at the sweep rate of the B time-base unit. When the A time-base unit is set to the delayed mode, the repetition rate of the Display Right Command is one-half the repetition rate of the MF Channel Switch Signal (Display B). This results in each vertical unit being displayed first against the A time-base unit (delaying), then the B time-base unit (delayed), before the display is switched to the other vertical unit.

The Display B Command is used in the following stages within the Logic Circuit: Plug-In Binary, Vertical Chopped Blanking, and Vertical Mode Logic. It is also connected to the following circuits elsewhere in the instrument to indicate which vertical unit is to be displayed (through Vertical Mode Logic stage; ALT vertical mode only): Main Interface, Trigger Selector, and Vertical Interface circuits.

The Vertical Binary stage uses the same type of IC as the Horizontal Binary stage. Figure 2-11 identifies the function of the input pins for U2535. Notice the Display A level at pin 7. This input is the inverse of the MF Channel Switch Signal (Display B) at pin 8. Therefore, the Display A level is always HI when the MF Channel Switch Signal (Display B) is LO, and vice versa. The following discussions describe the operation of the Vertical Binary stage in relation to the modes of operation that can occur.

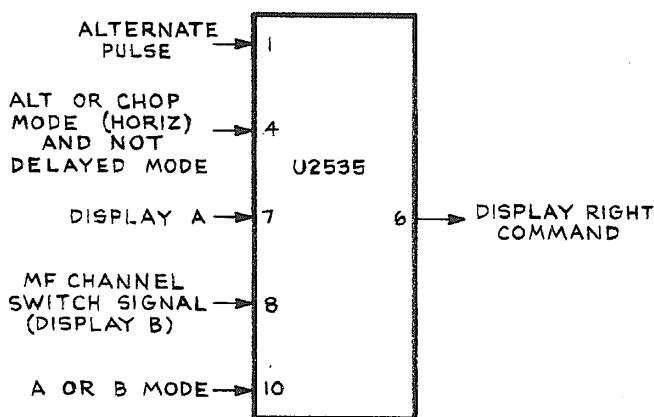

Fig. 2-11. Input and output pins for Vertical Binary IC.

NOTE

Although the output at pin 6 of U2535 is always controlled by the HORIZONTAL MODE switch as described here, this level determines the MF Channel Switch Signal (Display Right) level at the collector of Q2556 only in the ALT position of the VERTICAL MODE switch due to AND gate CR2552-CR2553. See the discussion of the Vertical Mode Logic stage in this section for further information.

1. A OR B MODE

When the HORIZONTAL MODE switch is set to either A or B, the Display Right Command switches to the opposite state each time an Alternate Pulse is received from the Horizontal Logic stage. Repetition rate of the Display Right Command in this mode is one-half the repetition rate of the Alternate Pulse. The input conditions for these modes are:

Pin 1 LO—Alternate Pulse generated by Horizontal Logic stage goes negative.

Pin 4 LO—HORIZONTAL MODE switch in any position except ALT or CHOP, or the A time-base unit is set for delayed sweep.

Pin 10 HI—HORIZONTAL MODE switch set to A or B.

2. ALT OR CHOP MODE (HORIZ)—NON-DELAYED

In the ALT or CHOP positions of the HORIZONTAL MODE switch, the output level at pin 6 is the same as the Display A level at pin 7. The Display A level is produced by inverting the MF Channel Switch Signal (Display B) from the Horizontal Binary stage. Therefore, the repetition rate of the output signal is the same as the MF Channel Switch Signal (Display B). The result, with the VERTICAL MODE switch set to ALT and the A time-base unit set for non-delayed operation, is that the RIGHT VERT unit is always displayed at the sweep rate of the A time-base unit, and the LEFT VERT unit at the sweep rate of the B time-base unit (sweep slaving). The input conditions to provide a HI output level so that the RIGHT VERT unit can be displayed at the A-sweep rate are:

Pin 4 HI—HORIZONTAL MODE switch set to ALT or CHOP with non-delayed sweep.

Pin 7 HI—A sweep is to be displayed; MF Channel Switch Signal (Display B) LO.

Pin 10 LO—HORIZONTAL MODE switch set to any position except A or B.

The input conditions to provide a LO output level so that the LEFT VERT unit can be displayed at the B-sweep rate are:

Pin 4 HI—HORIZONTAL MODE switch set to ALT or CHOP with non-delayed sweep.

Pin 7 LO—B sweep is to be displayed; MF Channel Switch Signal (Display B) HI.

Pin 10 LO—HORIZONTAL MODE switch set to any position except A or B.

Circuit Description—7704A Service

The Display Right Command switches from HI to LO along with the Display A level at pin 7 (inverse of MF Channel Switch Signal, Display B). However, notice that the Display Right Command changes from HI to LO as the MF Channel Switch Signal (Display B) changes from LO to HI, and vice versa.

3. ALT OR CHOP MODE (HORIZ)—DELAYED

If the A time-base unit is set to the delayed mode when the HORIZONTAL MODE switch is set to either ALT or

CHOP, the operation of the stage is changed from that discussed above. Now, the Display Right Command switches between the HI and LO states at a rate that is one-half the repetition rate of the MF Channel Switch Signal (Display B). The resultant CRT display allows the RIGHT VERT unit to be displayed first against the A sweep (delaying) and then against the B sweep (delayed). Then the display switches to the LEFT VERT unit and is displayed consecutively against the A and B sweeps in the same manner. The input conditions for this mode of operation are:

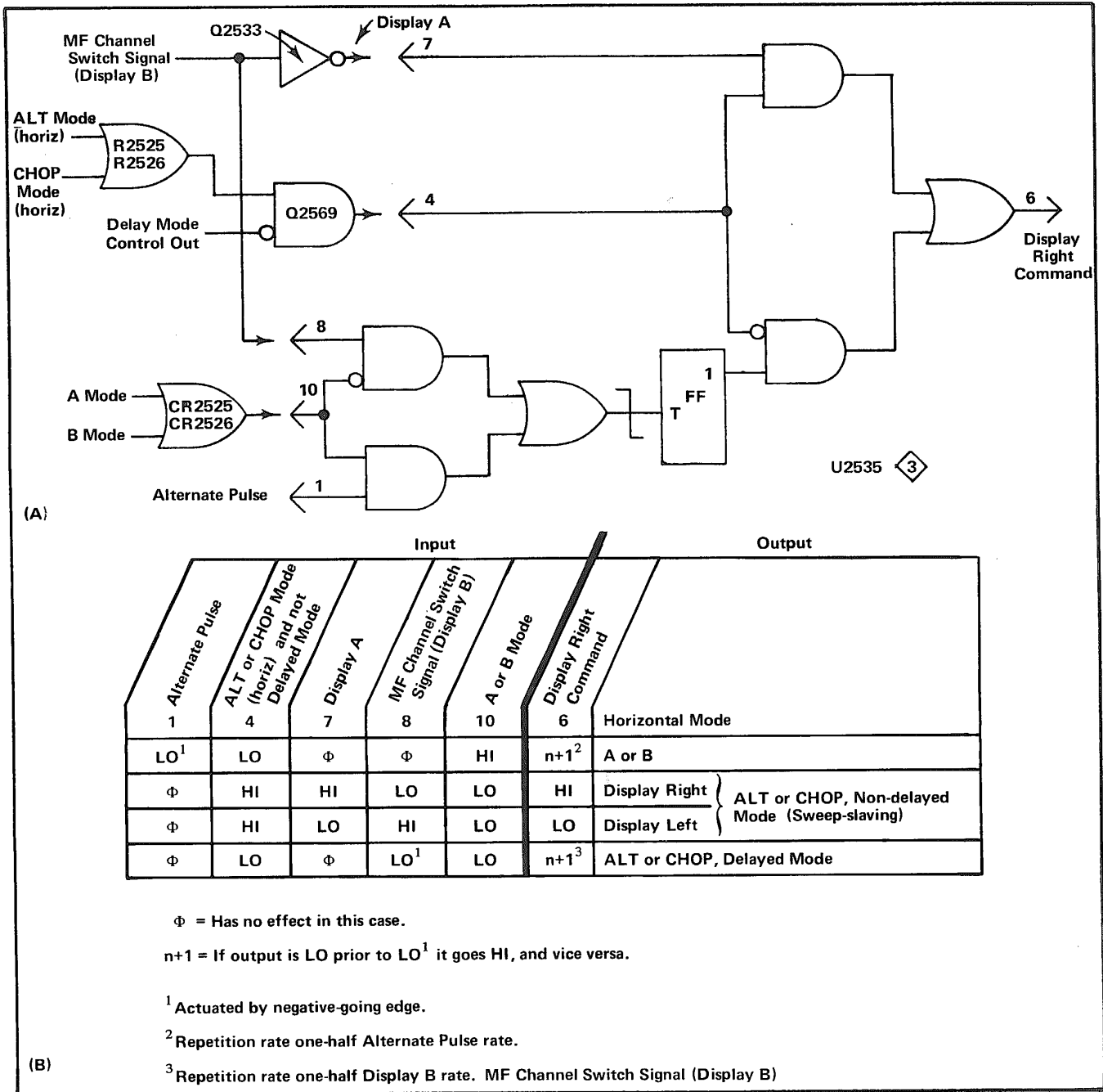

Fig. 2-12. (A) Logic diagram for Vertical Binary stage; (B) Table of input/output combinations.

Pin 4 LO—A time-base unit set for delayed operation.

Pin 8 LO—MF Channel Switch Signal (Display B) generated by Horizontal Binary stage goes negative.

Pin 10 LO—HORIZONTAL MODE switch set to any position except A or B.

A logic diagram of the Vertical Binary stage is shown in Fig. 2-12A. Several logic functions in this stage are performed by logic devices made up of discrete components. The components that make up these logic devices are identified on the Logic diagram. An input/output table for the Vertical Binary stage is given in Fig. 2-12B.

Plug-In Binary

The Plug-In Binary stage produces the Alternate Drive signal to provide a plug-in alternate command to dual-trace plug-in units. This stage uses the same type of IC as the Horizontal Binary and Vertical Binary stages. Figure 2-13 identifies the function of the input pins for the Plug-In Binary IC, U2540.

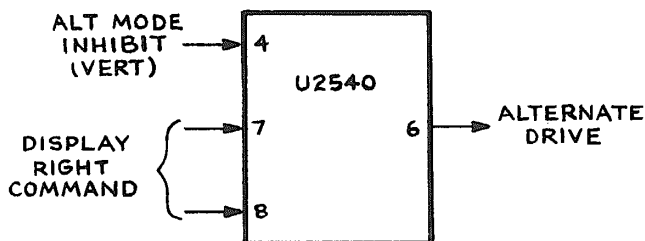

Fig. 2-13. Input and output pins for Plug-In Binary IC.

When the Alternate Drive level is HI and the plug-in unit is set for alternate operation, Channel 2 of the dual-trace unit is displayed. When it is LO, Channel 1 is displayed. The repetition rate of the Alternate Drive output is determined by the setting of the VERTICAL MODE switch. For all positions except ALT, the Alternate Drive level is the same as the Display Right Command from the Vertical Binary stage. Since the Display Right Command was derived directly from the MF (Main Frame) Channel Switch Signal (Display B), this allows the two channels of a dual-trace

vertical unit to be slaved to the time-base units (non-delayed, dual-sweep horizontal modes only) in the same manner as previously described for slaving between the vertical and time-base units. The resultant CRT presentation, when the dual-trace unit is set for alternate operation, displays the Channel 1 trace at the sweep rate of the B time-base unit and the Channel 2 trace at the sweep rate of the A time-base unit. Input conditions for a LO output so that Channel 1 of the vertical plug-in can be displayed at the B-sweep rate are:

Pin 4 HI—VERTICAL MODE switch set to any position except ALT.

Pin 7 HI—A sweep to be displayed.

The Alternate Drive switches from HI to LO as the MF Channel Switch Signal (Display B) from the Horizontal Binary stage switches from LO to HI, and vice versa.

When the VERTICAL MODE switch is set to ALT, the Display Right Command from the Vertical Binary stage switches the vertical display between the two vertical units. However, if either of the vertical plug-in units are dual-trace units, they can be operated in the alternate mode also. To provide a switching command to these units, the Plug-In Binary stage produces an output signal with a repetition rate that is one-half the repetition rate of the Display Right Command. The sequence of operation, when two dual-trace vertical units are installed in the vertical plug-in compartments and they are both set for alternate operation, is as follows (VERTICAL MODE and HORIZONTAL MODE switches set to ALT): 1. Channel 1 of LEFT VERT unit at sweep rate of B time-base unit, 2. Channel 1 of RIGHT VERT unit at sweep rate of A time-base unit, 3. Channel 2 of LEFT VERT unit at sweep rate of B time-base unit, 4. Channel 2 of RIGHT VERT unit at sweep rate of A time-base unit. Notice that under these conditions, both channels of the LEFT VERT unit are displayed at the B-sweep rate and that both channels of the RIGHT VERT unit are displayed at the A-sweep rate. The repetition rate at the output of this stage is one-half the Display Right Command rate. Input conditions, when the VERTICAL MODE switch is set to ALT, are:

Pin 4 LO—VERTICAL MODE switch set to ALT.

Pin 8 LO—Display Right Command generated by Vertical Binary stage goes negative.

Figure 2-14A shows a logic diagram of the Plug-In Binary stage. An input/output table for this stage is shown in Fig. 2-14B.

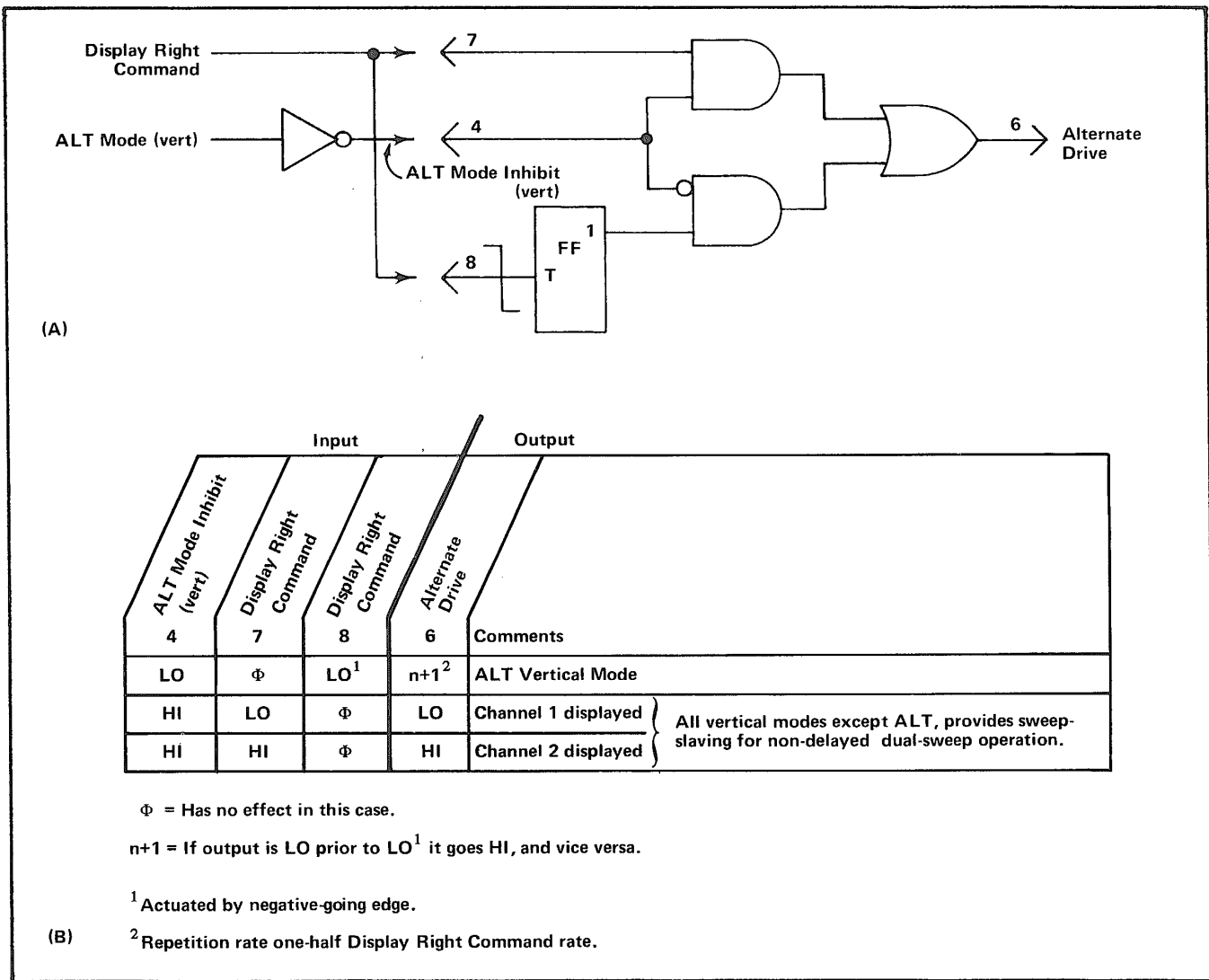

Fig. 2-14. (A) Logic diagram for Plug-In Binary stage; (B) Table of input/output combinations.

Clock Generator

Part of integrated circuit U2510, along with the external components shown in Fig. 2-15A, make up the Clock Generator stage. R1, Q1, Q2, and Q3 represent an equivalent circuit within U2510. The output at pin 15 is a free-running timing (Clock) signal used to synchronize the vertical, horizontal, and plug-in chopping modes.

The frequency of the Clock signal is either 200 kilohertz or two megahertz, depending on the position of the internal Chop Frequency switch S2510. The 200-kilohertz output is provided for other systems using the A7704 Acquisition Unit (the bottom half of the 7704A). For normal operation of the 7704A, the Chop Frequency switch should be left in the 2-MHz position.

When the internal Chop Frequency switch is in the 200-kHz position, the stage operates as follows: At time T_0 (see Fig. 2-15B), the collector current through Q2 is producing a voltage drop across R1 to cut off Q1. Since there is no current through Q1, C2510 and C2511 begin to charge towards -15 volts through R2510-R2511. This causes the emitter of Q1 to gradually go negative until it is about 0.6 volt more negative than the base. At this point (T_1 on Fig. 2-15B), Q1 is forward biased into conduction and its emitter rapidly goes positive. Since the charge on C2510-C2511 cannot change instantaneously, the sudden change in voltage at the emitter of Q1 pulls the emitter of Q2 positive also, to reverse-bias it into cutoff. When the current through Q2 stops, its collector rises to produce a positive output level at pin 14 (time T_1).

During time T_1 - T_2 , conditions are reversed. Since Q2 is biased off, there is no current through it and C2510-C2511 begins to discharge through R2512-R2513. The emitter level of Q2 follows the discharge of C2510-C2511 until it is about 0.6 volt more negative than the base. This forward biases Q2 and its collector drops negative to reverse-bias Q1. The level at pin 14 drops negative also, to complete the cycle. Once again, C2510-C2511 begin to charge through R2510-R2511 to start the second cycle. When S2510 is set to the 2-MHz position, R2512 is bypassed and one end of C2511 is disconnected from the RC timing circuit. The decreased RC time allows C2510 to charge and discharge at a two-megahertz rate.

Two outputs are provided by this oscillator: The Delay Ramp signal from Q1 or Q2 is connected to the Vertical Chopped Blanking stage, and a square-wave output from pin 14. The square wave at pin 14 is connected to pin 16 through an external capacitor, C2510. C2510 differentiates the square wave from pin 14 to produce a negative-going pulse coincident with the falling edge of the square wave (see pin-16 waveform on Fig. 2-15B). This negative-going pulse is connected to pin 15 through an inverter-shaper which is part of U2510. The resulting output at pin 15 is a

positive-going Clock pulse at a repetition rate of either 200 kilohertz or two megahertz, depending on the position of S2510.

Vertical Chopped Blanking

The Vertical Chopped Blanking stage is made up of the remainder of U2510. This stage determines if Vertical Chopped Blanking pulses are required, based upon the operating mode of the vertical system or the plug-in units (dual-trace units only). Vertical Chopped Blanking pulses are produced if: 1. VERTICAL MODE switch is set to CHOP; 2. Dual-trace vertical unit is operating in the chopped mode and that unit is being displayed; 3. Dual-trace vertical unit is operating in the chopped mode with the VERTICAL MODE switch set to ADD. The repetition rate of the negative-going Vertical Chopped Blanking pulse output at pin 4 is 0.2 or two megahertz for all of the above conditions (determined by the Clock Generator stage).

Figure 2-16 shows a logic diagram and an input/output table for the Vertical Chopped Blanking stage. Notice the comparator block on the diagram. The output of this comparator is determined by the relationship between the levels of its inputs. If pin 10 is more positive (HI) than the grounded input, the output is HI also; if it is more negative, the output is LO.

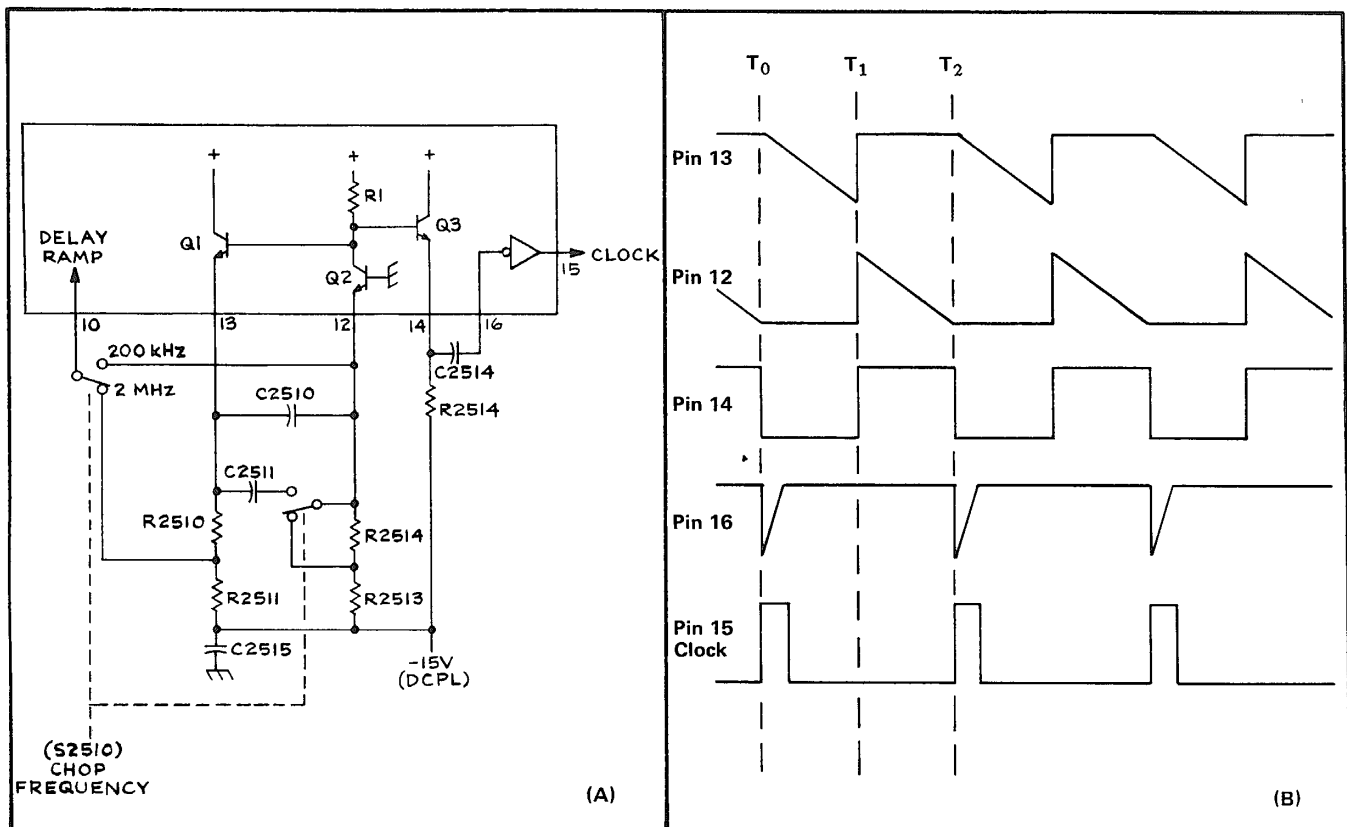

Fig. 2-15. (A) Diagram of Clock Generator stage; (B) Idealized waveforms for Clock Generator stage.

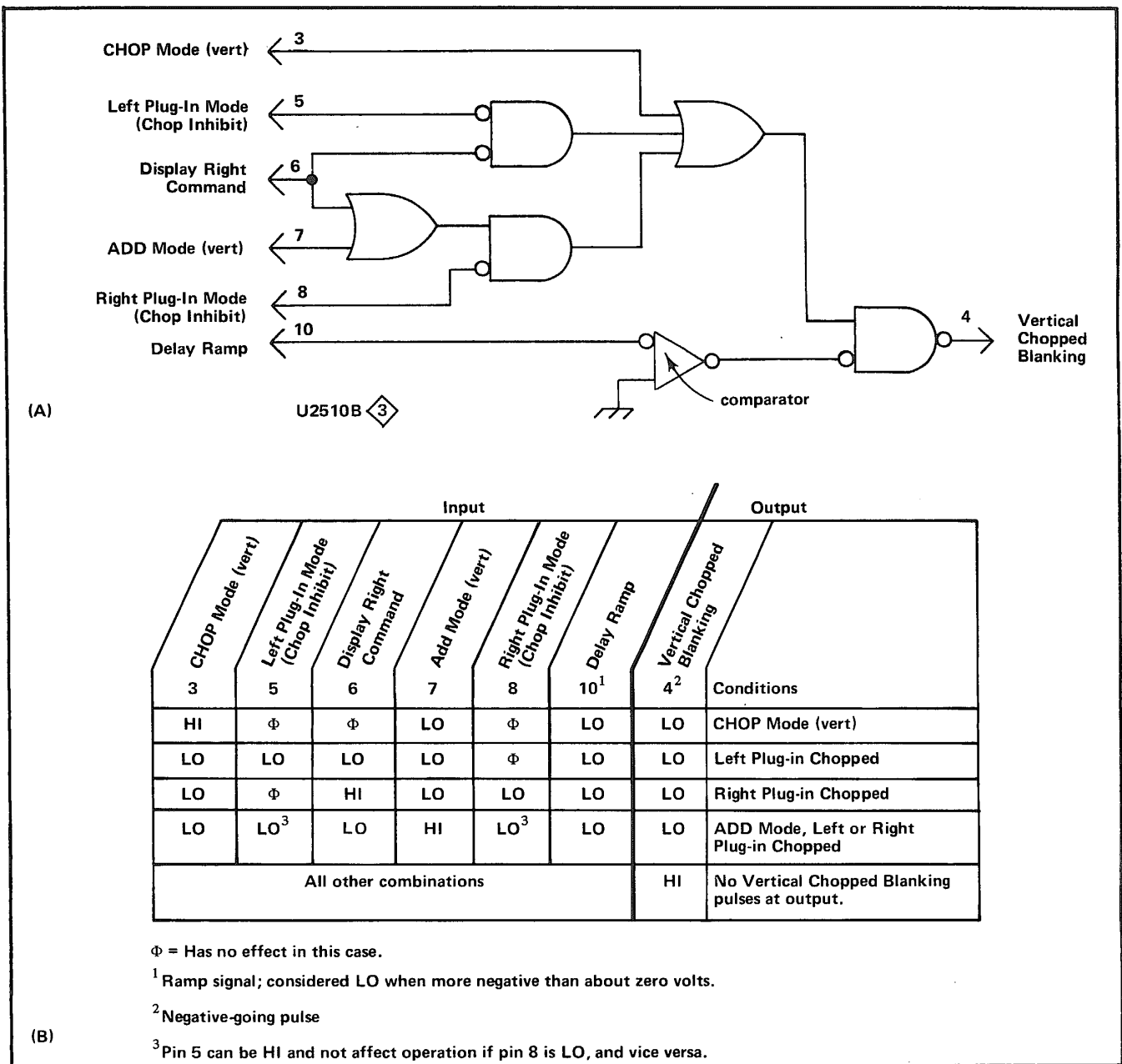

Fig. 2-16. (A) Logic diagram for Vertical Chopped Blanking stage; (B) Table of input/output combinations.

The Delay Ramp signal from the Clock Generator stage determines the repetition rate and pulse width of the Vertical Chopped Blanking pulses. The Delay Ramp applied to pin 10 starts to go negative from a level of about +1.1 volts coincident with the leading edge of the Clock pulse (see waveforms in Fig. 2-17). This results in a HI quiescent condition for the Vertical Chopped Blanking pulse. The slope of the negative-going Delay Ramp is determined by the Clock Generator stage. As it reaches a level slightly negative from ground, the Vertical Chopped Blanking pulse output level changes to the LO state and remains LO until the Delay Ramp goes HI again.

Notice the delay between the leading edge of the Clock pulse generated by U2510A, and the leading edge of the Vertical Chopped Blanking pulses. The amount of delay between the leading edges of these pulses is determined by the Delay Ramp applied to pin 10. This delay is necessary due to the delay line in the vertical deflection system. Otherwise, the trace blanking resulting from the Vertical Chopped Blanking pulse would not coincide with the switching between the displayed traces. The duty cycle of the square wave produced in the Clock Generator stage determines the pulse width of the Vertical Chopped Blanking pulses (see Clock Generator description for more information).

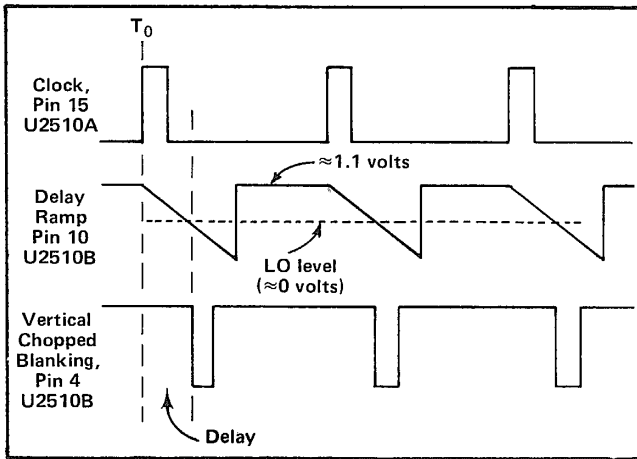

Fig. 2-17. Idealized waveforms for Vertical Chopped Blanking stage.

Chop Counter

The Chop Counter stage of U2520 produces the Vertical Chopping Signal (pin 1), the (Vertical) Chop Drive (pin 8), and the Horizontal Chopped Blanking signal (pin 4). A logic diagram for U2520 is shown in Fig. 2-18, along with waveforms showing the timing relationship between the input and output signals for this stage.

When the HORIZONTAL MODE switch is set to any position except CHOP, pin 6 remains LO and the repetition rate of the Vertical Chopping Signal at pin 1 is one-half the Clock rate (see time T_0 to T_1). This determines the switching rate between the left and right vertical compartments when the VERTICAL MODE switch is set to CHOP.

At the same time, the repetition rate of the (Vertical) Chop Drive at pin 8 is one-fourth the Clock rate. This provides a chopping signal to dual-trace vertical units to provide switching between the two channels. During this time, the level at pin 4 will remain HI.

When the HORIZONTAL MODE switch is set to CHOP, the basic repetition rate of the Vertical Chopping Signal and the (Vertical) Chop Drive is altered. For example, if the HORIZONTAL MODE switch is changed at time T_1 (see Fig. 2-18), a HI level is applied to pin 6. Outputs at pins 1 and 8 will be produced in the normal manner until both outputs are HI. (See time T_2 ; this condition only occurs once every fifth Clock pulse and only when the HORIZONTAL MODE switch is set to CHOP.) When both of these outputs are at their HI level, the next Clock pulse (at time T_3) switches both outputs LO, and at the same time, switches the Horizontal Chopped Blanking output to the LO level, where it remains until the start of the next Clock pulse.

This change at time T_3 does not appear at pin 4 immediately, due to a delay network in the circuit. (The delay is necessary to make the Horizontal Chopped Blanking coincide with the Vertical Chopped Blanking produced by U2510A; compare bottom two waveforms of Fig. 2-18. Also, see Vertical Chopped Blanking description.) After the delay time, the output level at pin 4 goes LO to blank the display.

The Horizontal Chopped Blanking time must be longer than the Vertical Chopped Blanking time, since it takes more time for the display to switch between horizontal units than between vertical units. During the time that the level at pin 4 is LO, the CRT is blanked and the Vertical Chopping Signal and the (Vertical) Chop Drive cannot change levels. The Clock pulse at T_3 changes only the Horizontal Chopped Blanking output. The level on pin 4 goes HI after the delay time to unblank the CRT.

For the next three Clock pulses, the Vertical Chopping Signal output and (Vertical) Chop Drive operate in the normal manner. However, at the fourth Clock pulse (Time T_4) both outputs are again at their HI level. The fifth Clock pulse at T_6 switches the output at pin 1, pin 8, and pin 4 (after delay) to the LO level to start the next cycle. Notice that a Horizontal Chopped Blanking pulse is produced at pin 4 with every fifth Clock pulse. Also notice that with the HORIZONTAL MODE switch set to CHOP, two complete cycles of the Vertical Chopping Signal are produced with each five Clock pulses (repetition rate, two-fifths Clock rate) and one complete cycle of the (Vertical) Chop Drive for every five Clock pulses (one-fifth Clock rate). Notice that the large shaded area produced by the Horizontal Chopped Blanking pulse (see Fig. 2-18) is not part of the display time (CRT display blanked). However, about the same time segment is displayed from the vertical signal source with or without Horizontal Chopped Blanking, due to the change in repetition rate when in the CHOP horizontal mode.

The Vertical Chopping Signal at pin 1 of U2520 is connected to the Vertical Mode Logic stage (see following description) through L2519-R2519. This signal is HI when the right vertical unit is to be displayed and LO when the left vertical unit is to be displayed. The (Vertical) Chop Drive at pin 8 is connected to the plug-in units in the vertical compartments through L2528-R2528 via the Main Interface board. When this signal is HI, Channel 2 of the plug-in units can be displayed; when this level is LO, Channel 1 is displayed. The Horizontal Chopped Blanking signal at pin 4 is connected through LR2523 to the Horizontal Binary stage U2530 and to the Z-Axis Logic stage U2573 by way of CR2524. When this signal is HI, the CRT is unblanked to display the selected signal. When it is LO, the CRT is blanked to allow switching between the horizontal units.

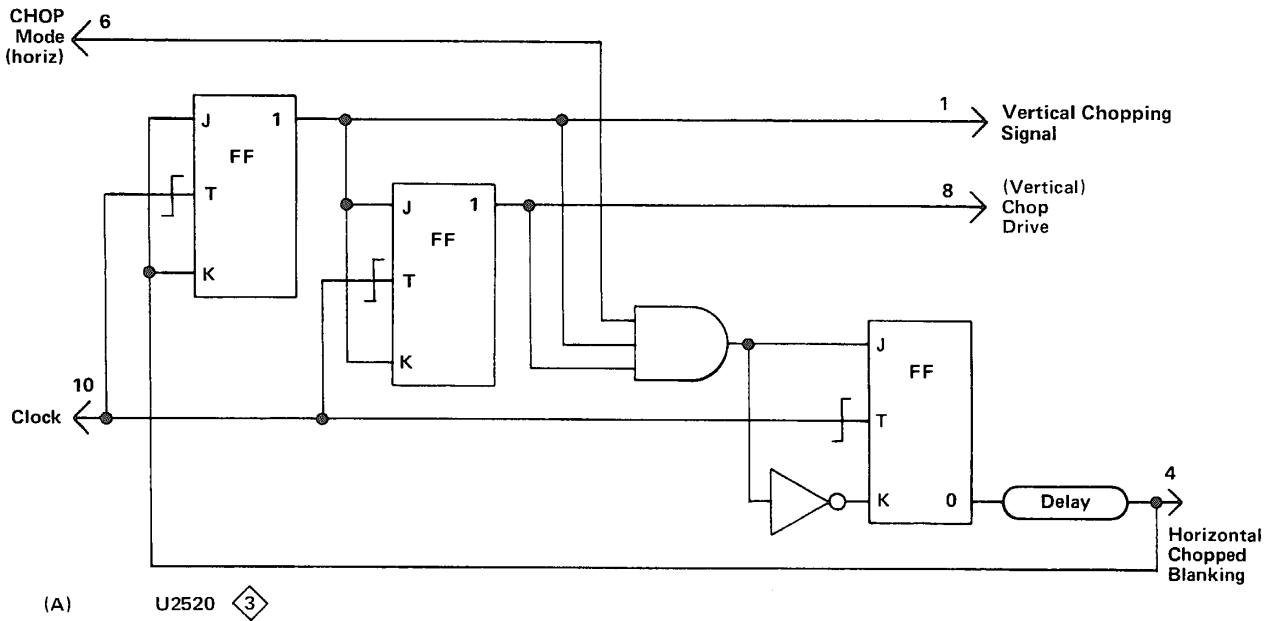

(A) U2520 3

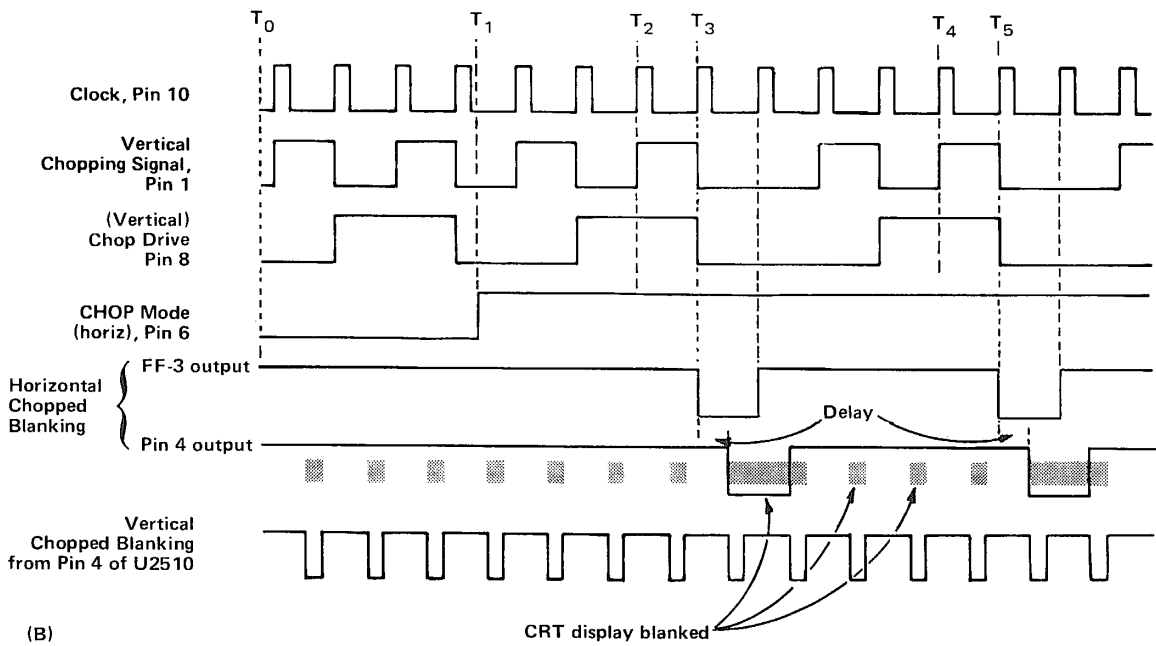

Fig. 2-18. (A) Logic diagram for Chop Counter stage; (B) Table of input/output combinations.

Vertical Mode Logic

The Vertical Mode Logic stage is made up of discrete components CR2501-CR2502, CR2552-CR2553, and Q2553-Q2556. These components develop the MF (Main Frame) Channel Switch Signal (Display Right). This signal is connected to the Main Interface circuit (vertical plug-in compartments and trigger-selection circuitry) and to the

Vertical Interface circuit to indicate which vertical unit is to be displayed. When this output level is HI, the right vertical unit is displayed; when it is LO, the left vertical unit is displayed.

The VERTICAL MODE switch shown on diagram 1 provides control levels to this stage. This switch provides a

HI level on one of five output lines to indicate the selected vertical mode; the remaining lines are LO (notice that only four of the lines from the VERTICAL MODE switch are used on this schematic). Operation of this stage is as follows:

When the VERTICAL MODE switch is set to RIGHT, a HI level is connected to the base of Q2553 through R2501. This forward-biases Q2553, and the positive-going level at its emitter is connected to the emitter of Q2556. The collector of Q2556 goes HI to indicate that the right vertical unit is to be displayed. For the CHOP position of the VERTICAL MODE switch, a HI level is applied to the anodes of CR2501-CR2502 through R2502. Both diodes are forward biased so that the Vertical Chopping Signal from pin 1 of U2520 can pass to the base of Q2553. This signal switches between the HI and LO levels at the Clock Generator rate and produces a corresponding MF Channel Switch Signal (Display Right) output at the collector of Q2556. When this output is HI, the right vertical unit is displayed and when it switches to LO, the left vertical unit is displayed.

In the ALT position of the VERTICAL MODE switch, a HI level is applied to the anodes of CR2552-CR2553 through R2551. These diodes are forward biased so the Display Right Command from pin 6 of the Vertical Binary stage can pass to the base of Q2553 to determine the MF Channel Switch Signal (Display Right) level. The Display Right Command switches between its HI and LO levels at a rate determined by the Vertical Binary stage.

The control levels in the LEFT and ADD positions of the VERTICAL MODE switch are not connected to this stage. However, since only the selected line from the VERTICAL MODE switch can be HI, the RIGHT, CHOP, and ALT lines must remain at their LO level when either LEFT or ADD are selected. Therefore, the base of Q2553 remains LO to produce a LO MF Channel Switch Signal (Display Right) output level at the collector of Q2556.

A logic diagram of the Vertical Mode Logic stage is shown in Fig. 2-19.

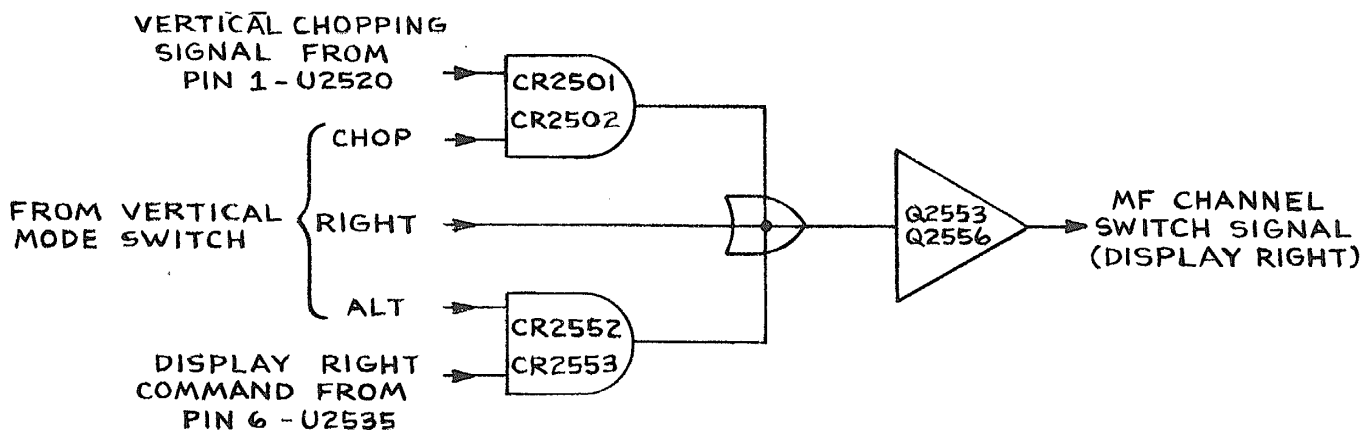

Fig. 2-19. Logic diagram of Vertical Mode Logic stage.

TRIGGER SELECTOR 4

The Trigger Selector circuit determines the source of the triggering signals connected to the A HORIZ and B HORIZ plug-in compartments. In addition, the B Trigger Selector stage provides the drive for the Vertical Signal Out amplifier (see diagram 7). Figure 2-20 shows a simplified diagram of the Trigger Selector circuit.

Trigger Modes

The switches shown on the left side of the diagram in Fig. 2-20 determine the operation of the Trigger Selector stages. When the A or B TRIGGER SOURCE switch is set to the LEFT VERT or RIGHT VERT position, the trigger signal is obtained from the indicated vertical compartment; when in the VERT MODE position, the VERTICAL MODE switch setting determines the trigger source. These switches are self-canceling; i.e., only one button on the switch can be pressed at a time.

The following discussion gives operating details for the A Trigger Selector stage; the operation of the B Trigger Selector stage is exactly the same except for the circuit numbers.

VERT MODE. In the VERT MODE position of the A or B TRIGGER SOURCE switch, the setting of the VERTICAL MODE switch determines the trigger source, as follows:

1. LEFT VERTICAL MODE

In the LEFT vertical mode, Q2090 is not biased on so pin 4 of U2404 is held LO by voltage divider R2093-R2094-R2095. Pin 14 of U2404 is held LO through CR1064 and CR1065. When pins 4 and 14 are both LO, the LEFT VERT unit supplies the trigger signal (see Fig. 2-21).

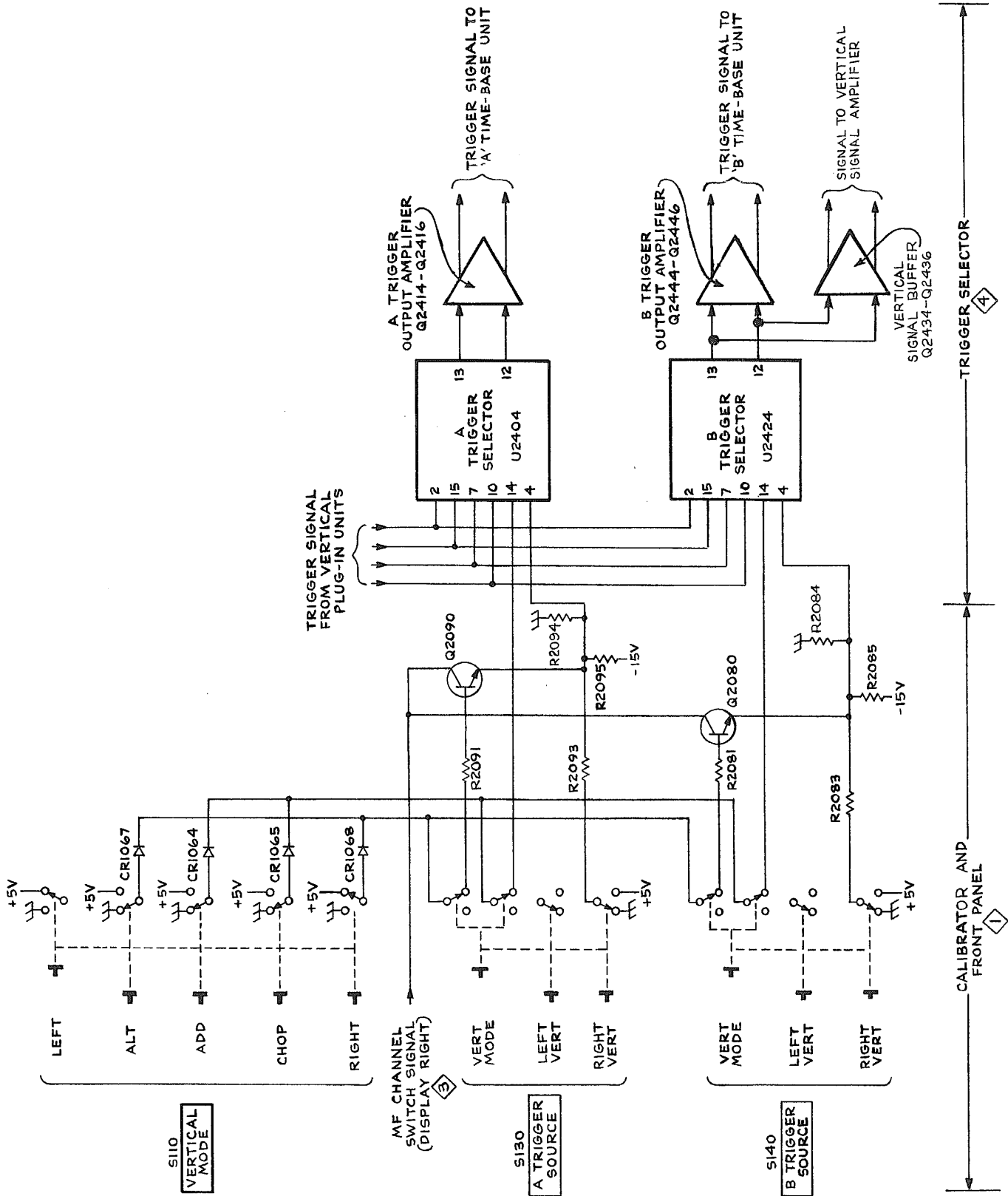

Fig. 2-20. Simplified schematic of trigger selection circuitry.

VERTICAL MODE switch positions		A and B TRIGGER SOURCE switch positions		
		LEFT	RIGHT	
VERTICAL MODE switch positions	LEFT	LO (Left Vertical)	↑	↑
	ALT	Switches from LO to HI, and vice versa, at end of each sweep (both; follows display)	↑	↑
	ADD	LO at pin 4 of U2404 and U2424. HI at pin 14 ¹ (both; added algebraically)	↓	↓
	CHOP			
	RIGHT	HI (Right Vertical)	↓	↓

¹ Pin 14 LO for all other conditions.

Fig. 2-21. Input levels at pin 4 of U2404 and U2424 (source of triggering signal is shown in parentheses).

2. ALT VERTICAL MODE

Depressing the ALT button of the VERTICAL MODE switch applies +5 volts to the anode of CR1067 to turn it on. Current through CR1067 forward biases Q2090 into saturation, causing the voltage at pin 4 of U2404 to follow the MF (Main Frame) Channel Switch Signal (Display Right) as it switches between HI (RIGHT VERT display) and LO (LEFT VERT display) at the end of each sweep. At the same time, pin 14 is held LO through CR1064 and CR1065. As a result, the sweep for the RIGHT VERT display is triggered by the RIGHT VERT signal, and the sweep for the LEFT VERT display is triggered by the LEFT VERT signal.

3. ADD OR CHOP VERTICAL MODE

For these two modes, Q2090 is not biased on, so pin 4 of U2404 is held LO by the negative voltage applied through R2095. Pin 14 will be HI due to the positive voltage applied through CR1064 or CR1065.

As indicated by the input/output table, when pin 4 is LO and pin 14 is HI, the trigger output signal is the algebraic sum of the trigger input signals from the LEFT VERT and RIGHT VERT compartments. This prevents triggering on the vertical chopping transition of a CHOP display, and on only one signal of an ADD display.

4. RIGHT VERTICAL MODE

In this mode, Q2090 is biased into saturation by current through CR1068. The MF Channel Switch Signal (Display Right) is HI in this mode, so a HI is produced at pin 4 of U2404. The anodes of CR1064 and CR1065 are grounded to hold pin 14 of U2404 LO. Under these conditions (pin 4 HI, pin 14 LO), the RIGHT VERT unit supplies the trigger signal.

LEFT VERT. Since only one button of the trigger source switch can be pressed in at a time, pressing LEFT VERT opens the contacts in the VERT MODE section of the trigger source switch so pins 4 and 14 remain LO. As indicated by the input/output table of Fig. 2-22, this causes the LEFT VERT unit to supply the trigger signal.

Input		Output
Trigger Mode Signal	Trigger ADD	Trigger Output Signal
4	14	12, 13
LO	LO	Left trigger signal
HI	LO	Right trigger signal
LO	HI	Both (added algebraically)

Fig. 2-22. Input/output table for A and B Trigger Selector stages.

RIGHT VERT. In the RIGHT VERT position of the trigger source switch, +5 volts is connected to R2093 of the voltage divider. This causes pin 4 of U2404 to go HI. At the same time, pin 14 is disconnected from its voltage source, causing it to stay at a LO level. Under these input conditions, the RIGHT VERT unit supplies the trigger output signal.

A and B Trigger Selector

The A and B Trigger Selector stages determine which input signal provides the trigger signal to the time-base units as controlled by the trigger mode and ADD signals from the trigger selection circuitry. Resistors R2401, R2402, R2421, and R2422 establish the input resistance of this stage and provide a load for the trigger output of the left and right vertical plug-in units. Resistors R2403-R2404-R2405 and R2406-R2407-R2408 establish the operating levels for the A Trigger Selector; R2403-R2405 and R2406-R2407 set the current gain for each channel. Resistors R2423-R2424-R2425 and R2427-R2428-R2429 establish

the operating level for the B Trigger Selector; R2423-R2425 and R2427-R2429 set the current gain for each channel. These stages are made up primarily of integrated circuits U2404 and U2424. An input/output table for U2404 and U2424 is shown in Fig. 2-22. U2404-U2424 provide a high-impedance differential input for the trigger signal from the left vertical unit at pins 2 and 15 and for the trigger signal from the right vertical unit at pins 7 and 10. The output signal at pins 12 and 13 is a differential signal. The sum of the DC current at pins 12 and 13 is always equal to the sum of the DC currents at pins 1, 8, 9, and 16 in all modes. This provides a constant DC bias to the following stages as the A or B TRIGGER SOURCE switches or the VERTICAL MODE switch are changed.

A Trigger Output Amplifier

Transistors Q2414 and Q2416 provide a low-resistance load for the A Trigger Selector IC while providing a high output impedance to the following circuits. (The A HORIZ unit provides a 50-ohm differential load for this circuit; if it is removed from its compartment, the voltage swing at the collectors of Q2414-Q2416 will increase substantially.)

B Trigger Output Amplifier

Q2444-Q2446 provide a low-resistance load for the B Trigger Selector IC while providing a high output impedance to the trigger circuit, and isolation between the B HORIZ trigger circuits and the Vertical Signal Out Amplifier.

The B HORIZ plug-in provides a 50-ohm differential load for Q2444-Q2446. If this plug-in is removed from its compartment, the collector load for these transistors changes and the voltage swing at their collectors increases. CR2444-CR2449 clamp the collectors of Q2444-Q2446 at about +0.6 volt to prevent these transistors from saturating under this no-load condition.

Vertical Signal Out Amplifier

The trigger output signal at pins 12 and 13 of the B Trigger Selector IC is also connected through Q2434-Q2436 to the Vertical Signal Out circuit. R2437 through R2441 provide a differential output resistance of about 100 ohms.

VERTICAL INTERFACE 5

The Vertical Interface circuit selects the vertical deflection signal from the output of the LEFT VERT or RIGHT VERT plug-in compartments. It also accepts an input from the Readout System to block the vertical signal while readout information is displayed on the CRT. In addition, this circuit contains the Vertical Trace Separation stage to shift the vertical position of one sweep of a dual-sweep display. Figure 2-23 shows a detailed block diagram of the Vertical Interface circuit.

Vertical Plug-In Selector

The Vertical Plug-In Selector determines which input signal provides the vertical signal to the Vertical Buffer

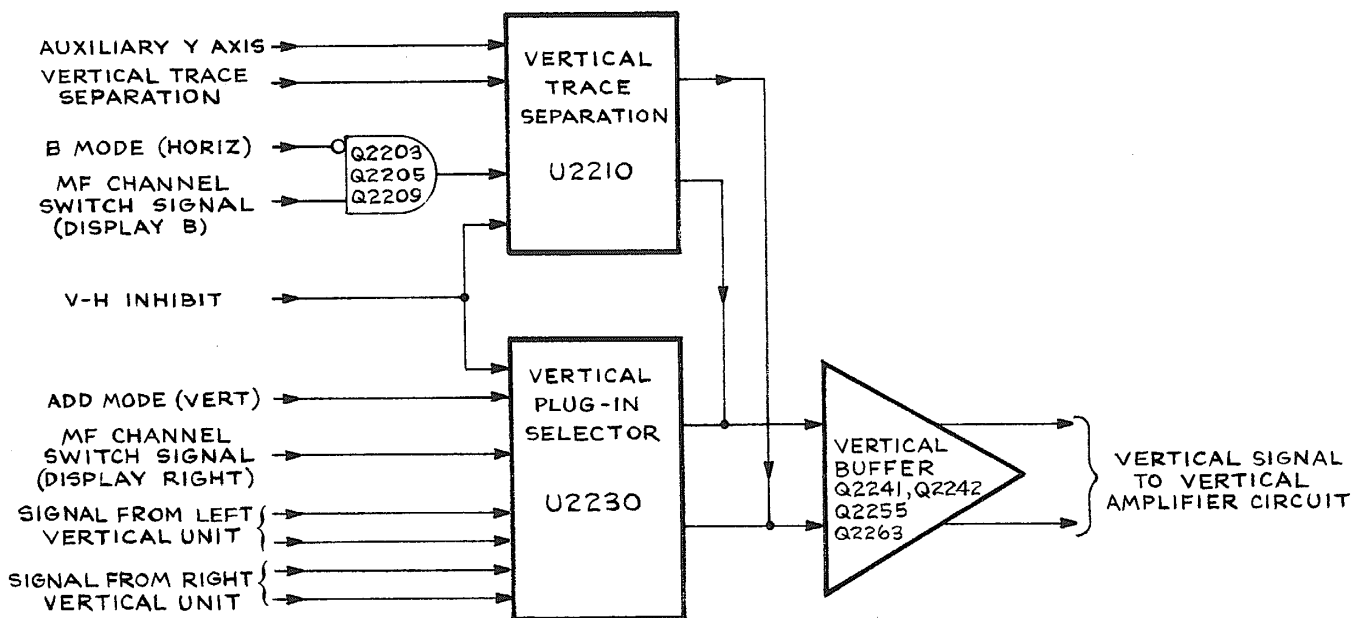

Fig. 2-23. Detailed block diagram of Vertical Interface circuit.

stage as controlled by the MF (Main Frame) Channel Switch Signal (Display Right) from the Logic Circuit. Resistors R2226-R2227 and R2228-R2229 establish the input resistance of this stage and provide a load for the left and right vertical plug-in units. Resistors R2237-R2239 and R2287-R2289 establish the operating levels for this stage. R2231 and R2281 set the current gain for each channel.

This stage is made up primarily of integrated circuit U2230, which is the same type as used for the Trigger Selector stages. An input/output table for U2230 is shown in Fig. 2-24. U2230 provides a high-impedance differential input for the signal from the left vertical unit at pins 2 and 15 and the signal from the right vertical unit at pins 7 and 10. The output signal at pins 12 and 13 is a differential signal, which is connected to the Vertical Buffer stage through R2241-R2242. The sum of the DC current at pins 12 and 13 is always equal to the sum of the DC currents at pins 1, 8, 9, and 16 in all modes. This provides a constant DC bias to the following stage as the VERTICAL MODE switch is changed.

When the VERTICAL MODE switch is set to LEFT, the level at pin 4 is LO. This level allows the signal from the left vertical unit to pass to the output while the signal from the right vertical unit is blocked. In the RIGHT position of the VERTICAL MODE switch, the level at pin 4 is HI. Now, the signal from the right vertical unit is connected to the output, while the signal from the left vertical unit is blocked.

When the VERTICAL MODE switch is set to either ALT or CHOP, the MF Channel Switch Signal (Display Right) at pin 4 switches between the LO and HI levels at a rate determined by either the Chop Counter or Vertical Binary stages (see Logic Circuit description). This action allows the signal from the left vertical unit to be displayed when the MF Channel Switch Signal (Display Right) is LO and the signal from the right vertical unit to be displayed when the MF Channel Switch Signal (Display Right) is HI. When ADD vertical mode operation is selected, a HI level is applied to pin 14 and the level at pin 4 is LO as determined by the Vertical Mode Logic stage in the Logic Circuit. This allows both the Right and Left Vertical signals to pass to the output pins. Now, the signal from both vertical units is algebraically added and the resultant signal determines the vertical deflection.

The V-H (Vertical-Horizontal) Inhibit signal from the Readout System that is applied to pin 6 has final control over the output signal from this stage. Quiescently, this signal is LO and the signal from the selected vertical unit can pass to output pins 12 and 13. However, when the Readout System is ready to display readout information, the level at pin 6 goes HI. This level blocks the signal from both vertical units, so there is no signal output from this stage under this condition.

Input			Output
MF Channel Switch Signal	ADD Mode (Verrt)	V-H Inhibit	Output signal
LO	LO	LO	Left vertical signal
HI	LO	LO	Right vertical signal
LO	HI	LO	Both (added algebraically)
Φ	Φ	HI	Neither (blocked by Readout System)

Φ = Has no effect in this case

Fig. 2-24. Input/output table for Vertical Plug-In Selector.

Vertical Trace Separation

The Vertical Trace Separation stage determines if the Auxiliary Y Axis input or Vertical Trace Separation input are added to the vertical deflection signal. These inputs provide a variable positioning voltage to vertically offset one trace of a dual-sweep display. The Auxiliary Y Axis input originates in a dual time-base unit in either horizontal compartment. The Vertical Trace Separation input from the front panel (see diagram 1) provides a means to position the B-sweep display with respect to the A-sweep display for ALT or CHOP horizontal modes.

Integrated circuit U2210 in the Vertical Trace Separation stage is the same type as used for the Vertical Plug-In Selector stage. The output of this stage at pins 13 and 12 of U2210 is connected to the Vertical Buffer stage through R2221 and R2224. An input/output table for the Vertical Trace Separation stage is shown in Fig. 2-25.

As shown by the input/output table, the Auxiliary Y Axis input is connected to the output independent of the HORIZONTAL MODE switch setting. The Vertical Trace Separation input is connected to the output only when the MF Channel Switch Signal (Display B) is HI in the ALT or CHOP horizontal modes.

The V-H Inhibit signal from the Readout System, applied to pin 6, has final control over the output signal from this stage. Quiescently, this signal is LO and the selected input can pass to the output. However, when the Readout System is ready to display readout information, the level at pin 6 goes HI. This level blocks the offset inputs to this stage, so they have no effect on the position of the readout display.

HORIZONTAL INTERFACE 6

Input			Output
MF Channel Switch Signal (Display B)	B Mode (Horiz)	V-H Inhibit	Aux Y Axis or Vert Trace Separation
LO	LO	LO	Aux Y Axis
HI	LO	LO	Both
Φ	HI	LO	Aux Y Axis
Φ	Φ	HI	Neither (Blocked By Readout System)

Φ = Has no effect in this case

Fig. 2-25. Input/output table for Vertical Trace Separation stage.

Vertical Buffer

The outputs of the Vertical Plug-In Selector and Vertical Trace Separation stages are connected to the emitters of Q2241-Q2242. This transistor pair is connected in the common-base configuration to provide a low-impedance load to the previous stages. Centering adjustment R2222 sets the quiescent level on the base of Q2242 to adjust the trace position when no inputs are applied to this circuit. Gain adjustment R2247 sets the collector degeneration of Q2241-Q2242 to adjust the stage gain. Q2255-Q2263 are connected in the common-collector configuration (emitter follower) to provide a low-impedance reverse termination for the delay line.

The Horizontal Interface circuit determines whether the signal from the output of the A horizontal or B horizontal plug-in unit provides the horizontal deflection signal. This circuit also accepts as input from the Readout System to block the horizontal signal while readout information is displayed on the CRT. Figure 2-26 shows a detailed block diagram of the Horizontal Interface circuit.

Horizontal Plug-In Selector

The Horizontal Plug-In Selector determines which input signal provides the horizontal deflection signal to the Horizontal Amplifier as controlled by the MF (Main Frame) Channel Switch Signal (Display B) from the Logic Circuit. Resistors R2301-R2302 and R2303-R2304 establish the input resistance of this stage and provide a load for the A and B horizontal units. Resistors R2317-R2319 and R2327-R2329 establish the operating levels for this stage. R2311-R2313-R2315-RT2315 and R2321-R2323-R2325-RT2325 establish the current gain for each channel. R2313 and R2323 are adjustable to match the current gain of the two channels. Thermistors RT2315 and RT2325 provide temperature compensation to stabilize the current gain for each channel.

This stage is made up primarily of U2320, the same type of IC as used in the Trigger Selector and Vertical Interface circuits. An input/output table for U2320 is shown in Fig. 2-27. U2320 provides a high-impedance differential input for the signal from the A horizontal unit at pins 2 and 15 and the signal from the B horizontal unit at pins 7 and 10. The output signal at pins 12 and 13 is a differential signal to drive the Horizontal Amplifier circuit. The sum of the DC current at pins 12 and 13 is always equal to the sum of the DC currents at pins 1, 8, 9, and 16. This provides a constant DC output current level to the following stage as the HORIZONTAL MODE switch is changed.

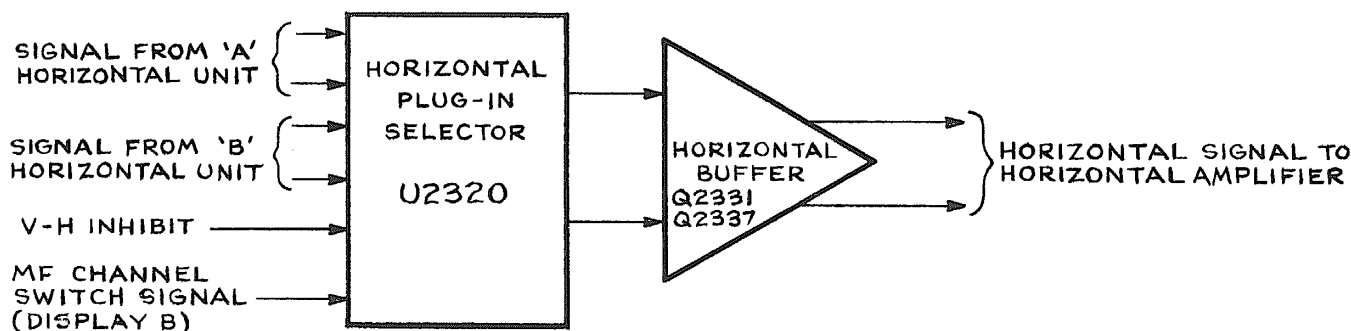

Fig. 2-26. Horizontal Interface circuit detailed block diagram.

OUTPUT SIGNALS 7

Input		Output
MF Channel Switch Signal (Display B)	V-H Inhibit	Output Signal
4	6	12,13
LO	LO	A Horizontal
HI	LO	B Horizontal
Φ	HI	Neither (blocked by readout system)

Φ = Has no effect in this case.

Fig. 2-27. Input/output table for Horizontal Plug-In Selector.

When the HORIZONTAL MODE switch is set to A, the level at pin 4 is LO. This level allows the signal from the A horizontal unit to pass to the output while the signal from the B horizontal unit is blocked. In the B position of the HORIZONTAL MODE switch, the level at pin 4 is HI. Now, the signal from the B horizontal unit is connected to the output while the signal from the A horizontal unit is blocked.

For ALT or CHOP positions of the HORIZONTAL MODE switch, the MF Channel Switch Signal (Display B) at pin 4 switches between the LO and HI levels at a rate determined by the Horizontal Binary stage in the Logic Circuit. This action allows the signals from the A horizontal unit to be displayed when the MF Channel Switch Signal (Display B) is LO and the signal from the B horizontal unit to be displayed when the MF Channel Switch Signal (Display B) is HI.

The V-H (Vertical-Horizontal) Inhibit from the Readout System, applied to pin 6, has final control over the output signal from this stage. Quiescently, this signal is LO to allow the signal from the selected horizontal unit to pass to the output. However, when the Readout System is ready to display readout information, the level at pin 6 goes HI. This level blocks the signal from both horizontal units, so there is no signal output from this stage under this condition.

Horizontal Buffer

The output signal from the Horizontal Plug-In Selector is connected to the Horizontal Amplifier circuit through the Horizontal Buffer stage. Transistors Q2331-Q2337 provide a low load impedance for U2320 as well as providing DC voltage matching between the Horizontal Interface and Horizontal Amplifier circuits.

The Output Signals circuit provides signals to the connectors located in the OUTPUTS section of the rear panel. These output signals are either generated within the instrument or are samples of signals from the associated plug-in units. In addition, this circuit contains the mode selection for the Readout System. Figure 2-28 shows a detailed block diagram of the Output Signals circuit.

Vertical Signal Amplifier

The vertical signal selected by the B Trigger Selector (see Trigger Selector description for more information) is connected to the bases of transistors Q3306-Q3308. The amplified signal is connected to buffer Q3312-Q3315 through an RC network which provides thermal balance for the circuit. CR3315 and CR3317 protect this stage if high-level voltages are accidentally applied to the VERT SIG OUT connector. CR3315 provides protection from positive voltages and CR3317 provides protection from negative voltages.

Sawtooth Amplifier

The sawtooth signals from the A and B time-base units are connected to the Sawtooth Amplifier stage through series resistors R2029 and R2019 respectively (See Diagram 2). Sweep Selector switch S3320 determines whether the A-sweep or the B-sweep sawtooth signal provides the +SAWTOOTH OUT signal. The unused sawtooth signal is terminated by R3320 to provide a constant load to the signal source.

Q3321-Q3323-Q3330 compose an inverting feedback amplifier. Gain of the stage is about two, as determined by the ratio of feedback resistor R3328 to the input resistance (made up of R3321 and either R2029 and R2019, depending on which sawtooth source is selected). RC network R3330-C3330 provides frequency-response stabilization for this stage.

CR3326 provides protection from high-amplitude positive voltages inadvertently connected to the output connector. This diode provides a current path to the +15-Volt supply through the collector-base junction of Q3330. When the diode is forward biased, it clamps the base of Q3330 at +15 volts. CR3333 provides protection from high-amplitude negative voltages at the SAWTOOTH OUT connector by clamping the output if it attempts to go more negative than about -15.6 volts.

Gate Amplifier

The + GATE OUT signal is selected from three input gate signals by Gate Selector switch S3340. In the A position, the A Gate signal from the A HORIZ compart-

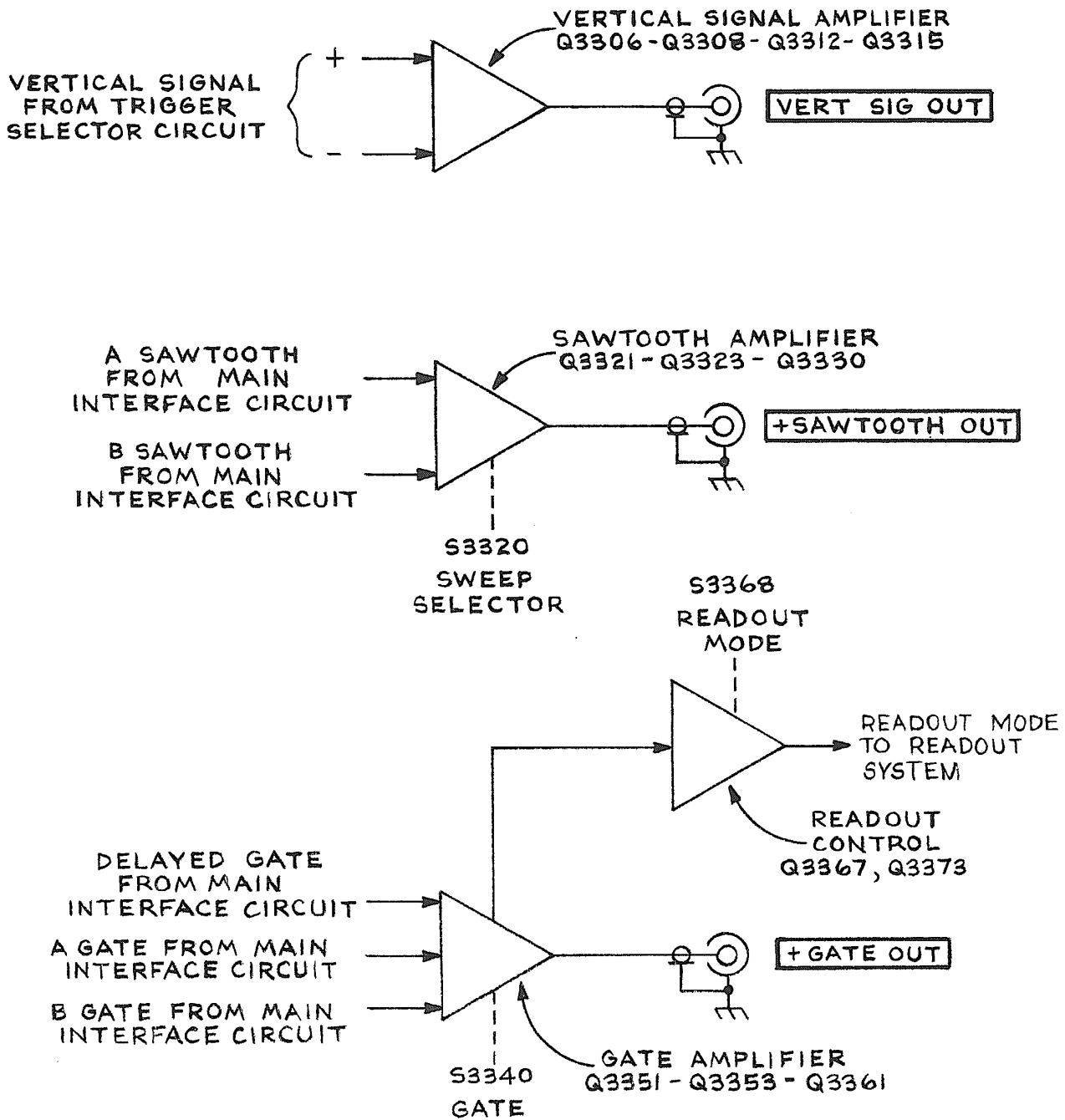

Fig. 2-28. Output Signals detailed block diagram.

ment is connected to the base of emitter-follower Q3351. The base of Q3353 is connected to ground by S3340 so the circuit operates as a common-base stage. Q3351 provides a high input impedance for the stage while the emitter coupling between the transistors provides temperature compensation. Operation is the same in the B position of the Gate Selector switch, except that the Gate signal from the B HORIZ compartment provides the input signal.

In the DIY'd position, the Gate Selector switch connects the base of Q3351 through R3349 to ground and

disconnects the A Gate and B Gate signals. The other section of the Gate Selector switch opens to allow the Delayed Gate signal from the delaying time-base unit to reach the base of Q3353. Q3353 inverts this negative-going Delayed Gate signal so that all three gate signals at the + GATE OUT connector are positive going.

CR3361 provides temperature compensation for Q3361. CR3363 protects Q3361 if a high-level positive voltage is applied to the + GATE OUT connector, and CR3364

clamps the collector of Q3361 at about -0.6 volt if a negative voltage is applied to the output connector.

Readout Control

Q3367 and Q3373, along with S3368, control the operating mode of the Readout System. When Readout Mode switch S3368 is in the Free-Run position, the Readout System runs continuously in a free-running manner. The emitter of Q3373 has no ground return, so Q3373 can not conduct and its collector rises positive (through circuitry in the Readout System) to enable the Readout System.

In the Gate Trig'd position, the emitter of Q3373 is connected to ground through R3373 and S3368 to produce a LO lockout level to the Readout System. At the end of the selected gate, a negative level is applied to the base of Q3367. This negative level is differentiated by C3368-R3368; the resulting negative-going pulse reverse biases Q3373 to momentarily allow its collector to go HI. This enables the Readout System so that it can produce one complete frame (eight words) each time the selected gate goes negative.

INVERTER/RECTIFIERS

The Inverter/Rectifiers circuit provides the operating power for this instrument from an AC line-voltage source. This circuit includes a Line Selector assembly to permit selection of the nominal operating voltage for the instrument. Figure 2-29 shows a detailed block diagram of the Inverter/Rectifiers circuit.

Line Input

Power is applied through the Line Filter, line fuse F3001, POWER switch S5020, and Line Selector switch S5022. The Line Filter is designed to keep power-line interference from entering the instrument and to keep the 25-kilohertz Inverter signal from entering the power line. L5020-L5022 provide common-mode EMI (electromagnetic interference) filtering with C5020-C5022, and differential filtering with C3005-C3006. R5020-R5022 provide common-mode resonance damping.

Line Selector switch S5022 allows the instrument to operate from either a 115-volt nominal or a 230-volt nominal line-voltage source. In the 115-volt position, rectifier CR3015 operates as a full-wave doubler with capacitors C3016-C3017 so the voltage across the two capacitors in series will be the peak-to-peak value of the line voltage. For 230-volt operation, CR3015 is connected as a bridge rectifier and C3016-C3017 operate as energy-storage filter capacitors. As a result, the output voltage applied to the Inverter stage is about the same for either 115-volt or 230-volt operation.

Thermistor RT3009 limits the surge current demanded by the power supply when it is first turned on. After the instrument is in operation, the thermistor resistance drops, so it has little effect on the operation of this stage. The stored charge on C3016 and C3017 limits the surge current if the POWER switch is turned off and back on after the resistance of RT3009 has dropped. If this occurs, the Inverter Control Line Stop stage will shut the Inverter off so that C3016 and C3017 will slowly discharge through R3021. The discharge time constant of C3016-C3017-R3021 is about equal but opposite to the thermistor thermal recovery time. This ensures sufficient thermistor resistance to limit the turn-on surge current to a safe level. Since C3016 and C3017 discharge slowly, dangerous potentials exist within the power supply for several minutes after the POWER switch is turned off. The presence of voltage in the circuit is indicated by the relaxation oscillator R3019-C3019-DS3019. Neon bulb DS3019 will blink until the potential across C3016-C3017 drops to about 80 volts.

DS3008-DS3013 are surge voltage protectors. When the Line Selector switch is in the 115-volt position, only DS3008 is connected across the line input. If a peak-voltage surge in excess of about 230 volts is present on the line (or if the instrument is accidentally connected to a 230-volt source), DS3008 will break down and demand high current. This excess current will quickly open line fuse F3001 to interrupt the input power before the instrument can be damaged. In the 230-volt position, DS3008 and DS3013 are connected in series across the line input to provide protection for peak voltages in excess of about 460 volts.

Transformer T3001 provides a sample of the line voltage to the plug-in connectors in the Main Interface circuit for internal triggering at line frequencies. This line-frequency signal is also connected to the Inverter Control Line Stop stage to indicate when line voltage is applied and the POWER switch is on.

The rectified output voltage from the Line Input stage is connected to the Start Network through Inverter fuse F3003. F3003 protects the Inverter stage if it demands excessive current due to a malfunction.

Start Network

The input line voltage is connected to divider R3010-R3048. This voltage charges C3048 on each half cycle. When the charge on C3048 reaches about 32 volts, trigger diode CR3040 conducts to provide a turn-on trigger current to Q3047 through C3042. This current allows the Inverter stage to start operating. After the Inverter stage is operating, the recurrent waveform at the collector of Q3047 keeps C3048 discharged through CR3046. This disables the Start Network while the instrument is on.

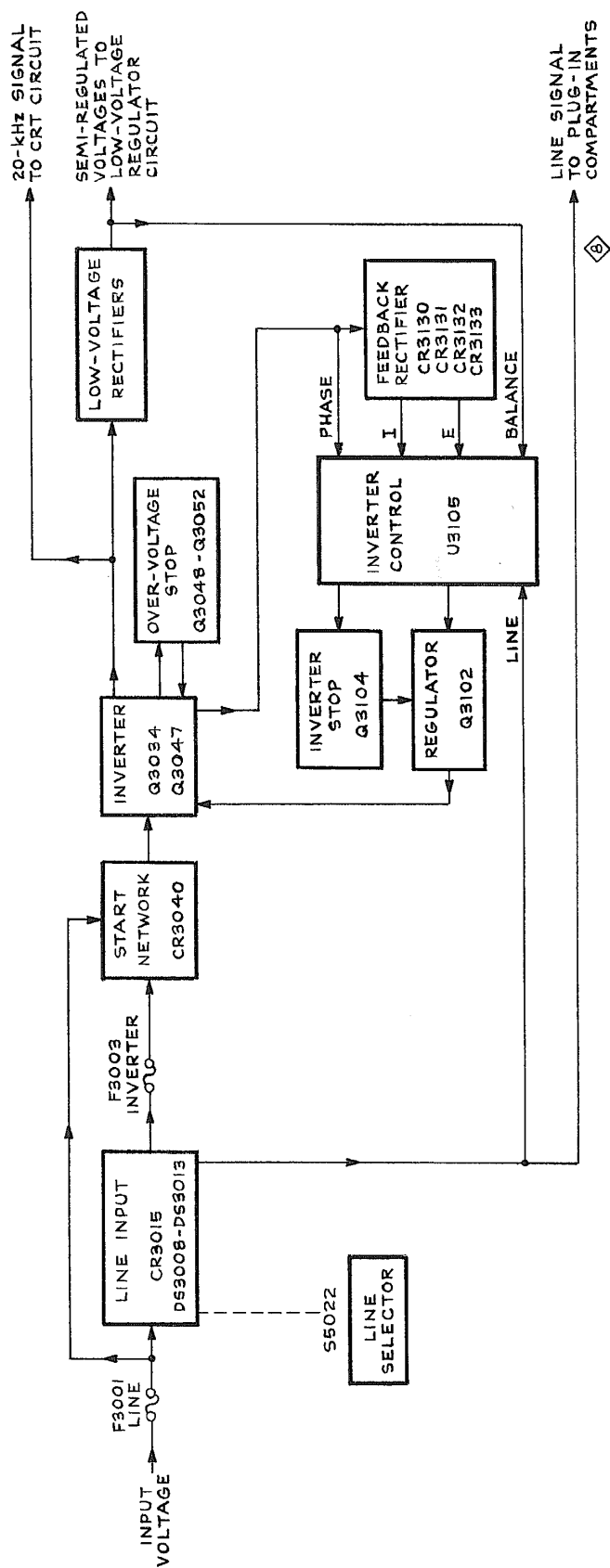

Fig. 2-29. Detailed block diagram of Inverter/Rectifiers circuit.

Inverter

A simplified schematic of the Inverter, Regulator, and Inverter Control stages is shown in Fig. 2-30. Once the Inverter has been started by the Start Network, the Inverter is self-oscillating. Feedback required for oscillation is provided by base-drive transformer T1. Polarity of the windings causes Q1 and Q2 to conduct alternately. This generates a square-wave voltage at the emitter of Q1 with an amplitude approximately equal to the DC voltage at the input to this stage. The switching action of Q1 and Q2 supplies the drive necessary to maintain a sine-wave current in series resonant circuit L1-C1. Notice that this sine-wave current is also common to the primaries of T1, T2, and T3.

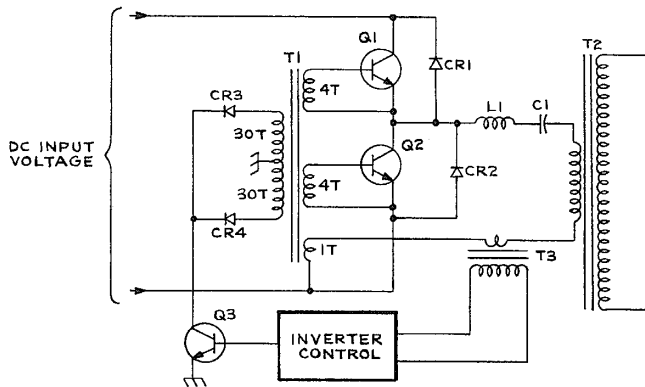

Fig. 2-30. Simplified schematic of Inverter, Regulator, and Inverter Control stages.

Q3 represents the Regulator stage, which is controlled by the Inverter Control stage. These stages are used to delay the turn-on of Q1 or Q2 to provide pre-regulation of the voltages induced in the secondary of T2. When Q3 is on, the voltages on all secondaries of T1 will be zero, and both Q1 and Q2 will be off. Current in the resonant circuit will flow through CR1 and CR2 when Q1 and Q2 are off. Transformer T3 samples the resonant-circuit current to provide current-phase information to the Pre-Regulator inputs of the Inverter Control stage to control the conduction of the Regulator stage.

The normal sequence of operation is as follows: Assume that the sine-wave current in the series resonant circuit is passing through zero and is increasing in the direction to cause CR1 to conduct. At zero crossing, Q3 turns on to hold Q2 off (CR1 will conduct as long as Q2 is off). At a controlled time after zero crossing, Q3 is turned off by the Inverter Control stage. Q2 then turns on, causing CR1 to be reverse biased. Q2 conducts as the current goes through its peak and back to zero.

At zero crossing, with current increasing in the opposite direction, Q3 turns on to hold Q1 off. During this Inverter

Control time, CR2 conducts while Q1 is off. When the Inverter Control stage turns Q3 off, Q1 will be turned on, causing CR2 to be reverse biased. Q1 conducts as the current goes through its peak and back to zero. The cycle then repeats with Q3 turning on to hold Q2 off.

Now, refer to the complete Inverter/Rectifiers diagram. The LC circuit is made up of L3037-C3037. After the circuit has been started by the Start Network, as discussed previously, L3037-C3037 resonates at a frequency of about 25 kilohertz. The feedback to the base circuits of Q3034-Q3047, through T3030, alternately turns Q3034 and Q3047 on. These transistors operate at a forced beta of four due to the turns ratio of T3030, and their output current sustains resonance in L3037-C3037. The 60-turn center-tapped winding of T3030 is used to delay the turn-on of Q3034 or Q3047 to provide pre-regulation of the voltages produced in the secondary of T3101. This operation will be discussed in more detail under Pre-Regulator. Diodes CR3034 and CR3045 provide reverse conduction paths across Q3034 and Q3047 respectively when these transistors are held off for pre-regulation purposes.

Over-Voltage Stop

Q3048 and Q3052 provide a means to stop the Inverter whenever the voltage across the primary of T3101 exceeds a safe level. This stage is activated whenever the load on T3101 is removed or the normal voltage regulating path through Q3102 and T3030 is inoperative.

CR3057 charges C3049 to the peak of the voltage across the primary of T3101. If this voltage exceeds a safe level, VR3059 will conduct and turn on Q3052. C3049 will discharge through R3052, Q3052, and the base-emitter junction of Q3048. This current turns Q3048 on to cause Q3047 to be held off and stop the Inverter. The Inverter cannot restart until CR3050 has charged C3048 to about 32 volts (the breakdown voltage of CR3040) to energize the Start Network.

Inverter Control

The Inverter Control stage, made up primarily of U3105, provides pre-regulation and fault protection for the low-voltage power supplies. For pre-regulation purposes, U3105 provides the Regulator output to the Regulator stage to vary the Inverter frequency. Fault protection is achieved through the Regulator output (as for pre-regulation) or by providing the Stop Trigger output to the Inverter Stop stage to turn the Inverter off.

U3105 includes a monostable multivibrator that is initially triggered by current-phase information fed back from the Inverter stage. The sensing inputs to U3105 determine the multivibrator pulse width. The multivibrator

Circuit Description—7704A Service

Regulator output drives the Regulator stage through pin 9-U3105. Under normal operating conditions, only the E Sense input at pin 15 has control over the output pulse width for pre-regulation. However, an error detected by any of the sensing inputs will affect the output pulse width and will also produce a Stop Trigger to the Inverter Stop stage. The operation of each individual function of the Inverter Control stage is described in the following discussions.

Pre-Regulator

The Pre-Regulator portion of U3105, in conjunction with the Regulator stage, maintains constant voltages at the outputs of the Low-Voltage Rectifiers.

Transformer T3035 provides Inverter power and phase information to U3105. The phase information is connected to the trigger input of the Inverter Control multivibrator via pins 10 and 11 through C3125 and C3126. Bridge rectifier CR3130-CR3131-CR3132-CR3133 provides positive and negative operating voltages to U3105. A shunt regulator in U3105 regulates the +7.5-volt output of the bridge rectifier connected to pin 6. The -2-volt (nominal) output connected to pin 7 is unregulated. VR3147 provides a stable reference voltage for the sensing-divider resistors R3142-R3143-R3144-R3146. In this divider, R3143 adjusts the voltage level at the E Sense input to the Pre-Regulator (pin 15-U3105) to set the output voltage of the Low-Voltage Rectifiers.

In the stable state of the Inverter Control multivibrator, the Regulator output at pin 9 is near ground to turn off the Regulator stage. After the Inverter current passes through zero, either pin 10 or pin 11 will go positive to trigger the Inverter Control multivibrator into its astable state. While the multivibrator is in the astable state, the Regulator output voltage level is positive to turn on the Regulator stage. The duration of the astable state is determined by the voltage level at the E Sense input at pin 15. If this voltage level is low, the duration is short. As this voltage level increases, the duration increases.

Fault Protection

The fault-protection portions of U3105 protect the power-supply components from damage due to short circuits, turn-on surge currents, and other malfunctions. When a fault is detected at the Balance or I Sense inputs (pins 2 and 13 respectively), a current output from the Sample Period Timer output (pin 1) charges C3114. If the detected fault lasts longer than about 30 milliseconds, C3114 charges positive enough to produce a Stop Trigger output at pin 8 to turn the Inverter off. When the Inverter is shut off, the current charging C3114 is interrupted and C3114 will discharge. After about 450 milliseconds, the Stop Trigger output will return to a near zero-volt level to

allow the Inverter to run. This cycle repeats until the fault is corrected; the Inverter is on for about 30 milliseconds, then off for about 450 milliseconds.

Inverter Current Limiter. The Inverter Current Limiter provides protection for the Inverter components from damage due to excessive current. Operation of this stage is similar to the Pre-Regulator (voltage regulation). The Inverter Current Limiter takes control of the Inverter Control Regulator output pulse width during turn-on or whenever an overload causes the Inverter current to reach the limit value.

R3137 is the current-sensing resistor. The voltage at the junction of R3137-R3136-CR3138 is the negative rectified Inverter current. The I Sense input at pin 13 is normally held positive through R3135. If the Inverter current increases, the voltage at the I Sense input will become more negative. The Inverter Control Regulator output pulse width increases until the Inverter current reaches a value to hold pin 13 near the zero-volt level. If the voltage at pin 13 remains near zero for more than approximately 30 milliseconds, the Stop Trigger output at pin 8 will go positive to trigger the Inverter Stop stage.

Balance. The Balance portion of U3105 provides short-circuit protection for the +5-Volt and -17-Volt outputs of the Low-Voltage Rectifiers. Voltage divider R3152-R3154-R3155 biases the Balance Sense input at pin 2 of U3105 near a zero-volt level. If one of the output voltages changes sufficiently to cause the voltage level at pin 2 to vary approximately 200 millivolts (positive or negative), a positive Stop Trigger output is produced at pin 8 of U3105.

Line Stop. The Line Stop portion of U3105 protects the Line-Input components from damage due to turn-on surge current. This is achieved by triggering the Inverter Stop stage to stop the Inverter when the POWER switch is turned off. The Line Stop stage will also stop the Inverter if the AC line voltage falls below a minimum value. (For further information, refer to the discussion of the Line Input stage.)

The line-frequency signal from transformer T3001 is connected to the Line Stop Sense input of U3105 at pin 4. During normal operation, the line-frequency signal causes the Line Stop Timer terminal (pin 3) to be near a zero-volt level (ground). This zero-volt level keeps C3117 from being charged toward +7.5 volts through R3117. When the line-frequency signal is interrupted or falls below a minimum value, C3117 will begin to charge to +7.5 volts. When the voltage at pin 3 reaches approximately +0.7 volt, the Line Stop stage will produce a positive Stop Trigger output at pin 8 of U3105 to trigger the Inverter Stop stage.

Regulator

The Regulator stage operates in conjunction with the Inverter Control and Inverter Stop stages to regulate the Inverter switching. Q3102 acts as a switch controlled by the Regulator output of U3105 (pin 9) or by the Inverter Stop stage. When Q3102 is turned on, CR3101 and CR3102 are forward biased. This effectively short circuits the 60-turn center-tapped winding of T3030 to shut off the Inverter. For further information, see the discussion of the Inverter stage.

Inverter Stop

The Inverter Stop stage, Q3104, is controlled by the Stop Trigger output of U3105 (pin 8) to shut off the Inverter through the Regulator stage. During the start period, T3030 supplies current to charge C3106-C3108 through CR3106-CR3108. Also during this time, Q3104 is reverse biased by U3105. Once triggered on by a positive Stop Trigger, Q3104 will stay on while C3106-C3108 discharge through the base of Q3104. If U3105 is removed from its socket or is otherwise non-functional, the Inverter Stop stage will stop the Inverter after the first few cycles of operation. In this mode, the duty cycle will be much shorter because C3106-C3108 will not have sufficient time to charge.

Low-Voltage Rectifiers

The rectifiers and filter components in the secondaries of T3101 provide rectified, pre-regulated voltages for further regulation by the Low-Voltage Regulators circuit. Error-sense voltages from the +54-Volt and lamp power (+5-Volt Lights) supplies are fed back to U3105 to control the amplitude of the Inverter drive to the Low-Voltage Rectifiers stage.

LOW-VOLTAGE REGULATORS

The Low-Voltage Regulators circuit converts semi-regulated voltages from the Inverter/Rectifiers circuit to stabilized, low-ripple output voltages. The -50-Volt Supply is referenced to a zener diode; the remaining four supplies are referenced to the -50-Volt Supply. Each supply contains a short-protection circuit to prevent instrument damage if a supply is shorted to ground or to another supply. Figure 2-31 shows a detailed block diagram of the Low-Voltage Regulators circuit.

-50-Volt Supply

The following discussion includes the description of the -50-V Series Regulator, -50-V Feedback Amplifier, -50-V Reference, and -50-V Current Limiting stages. Since these stages are closely related in the production of the -50-volt regulated output voltage, their operation is most easily understood when discussed as a unit.

Semi-regulated -54 volts from the Inverter/Rectifiers circuit provides the unregulated voltage source for this supply. Transistors Q32130-Q32115-Q32143 operate as a feedback-stabilized regulator circuit to maintain a constant -50-volt output level. Q32130 is connected as a differential amplifier to compare the feedback voltage at the base of Q32130B against the reference voltage at the base of Q32130A. The error output at the collector of Q32130B reflects the difference, if any, between these two inputs. The change in error-output level at the collector of Q32130B is always in the opposite direction to the change in the feedback input at the base of Q32130B (out of phase).

Zener diode VR32127 sets a reference level of about -9 volts at the base of Q32130A. A sample of the output voltage from this supply is connected to the base of Q32130B through divider R32132-R32133-R32134. R32133 in this divider is adjustable to set the output level of this supply. Notice that the feedback voltage to this divider is obtained from a line labeled -50 V Sense. If the feedback voltage were obtained at the supply, the voltage at the load would not stay constant, due to the inherent resistance of the interconnecting cable between the supply and its load (as the load current varies, the voltage drop along the cable also varies). The Sense configuration overcomes this problem by sensing the voltage at the load. Since the current in the Sense line is small and constant, the load voltage is held constant regardless of the load current.

Regulation occurs as follows: If the output level of this supply decreases (less negative) due to an increase in load or a decrease in input voltage (as a result of line-voltage changes or ripple), the voltage across divider R32132-R32133-R32134 decreases also. This results in a more positive feedback level at the base of Q32130B than that established by the -50-V Reference stage at the base of Q32130A. Since the transistor with the more positive base controls the conduction of the differential amplifier, the output current at the collector of Q32130B increases. This increase in output from Q32130B increases the current through Q32115. This allows more current to flow through Q32143 to result in increased conduction of the -50-V Series Regulator Q32139. The load current increases and the output voltage of this supply also increases (more negative). As a result, the feedback voltage from the -50-V Sense line increases and the base of Q32130B returns to the same level as the base of Q32130A. Similarly, if the output level of this supply increases (more negative), the output current of Q32130B decreases. The feedback through Q32115 and Q32143 reduces the conduction of the -50-V Series Regulator to decrease the output voltage of this supply. The -50 Volts adjustment R32133 determines the divider ratio to the base of Q32130B and thereby determines the feedback voltage.

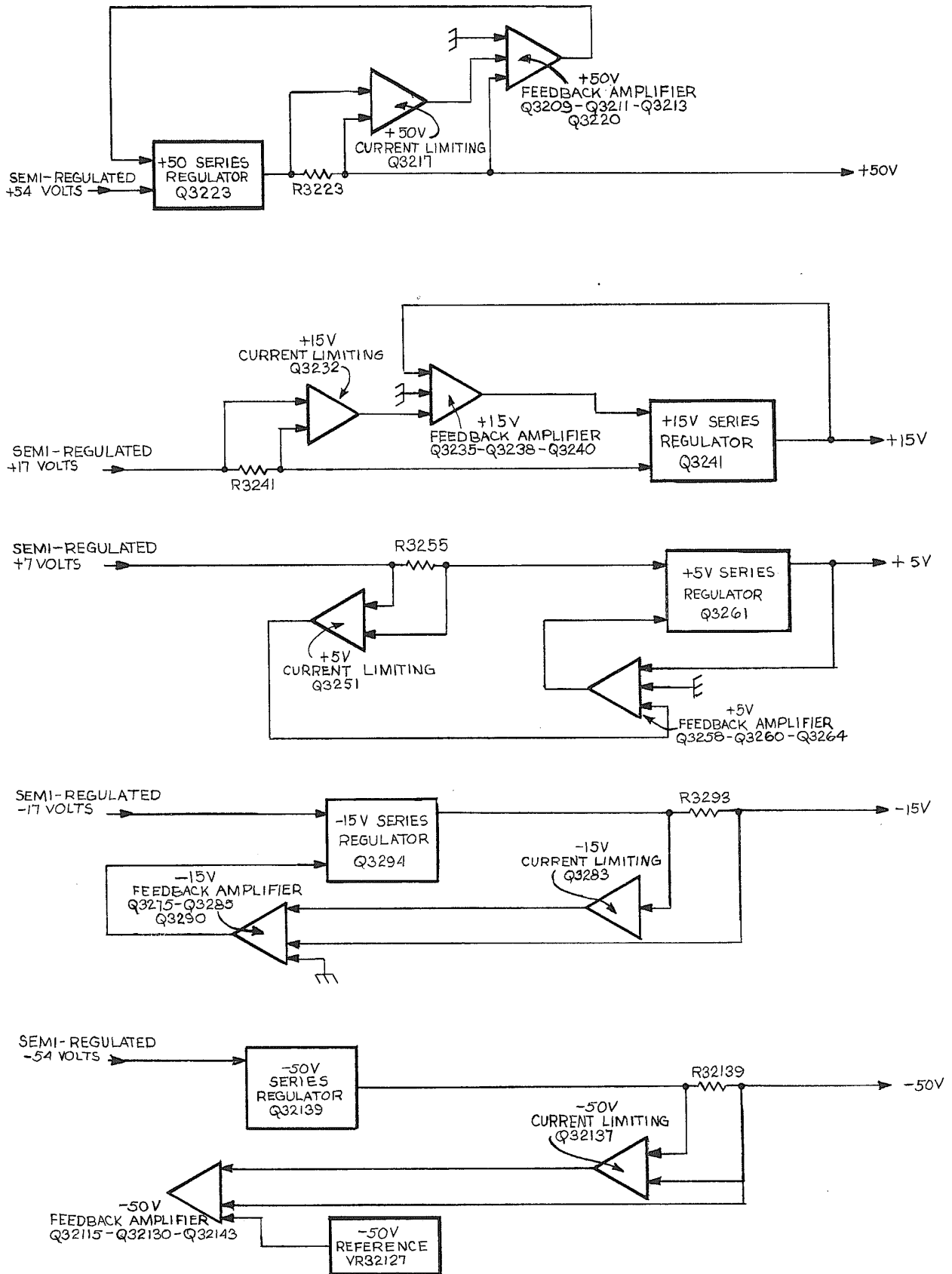

Fig. 2-31. Detailed block diagram of Low-Voltage Regulators circuit.

The -50-V Current Limiting stage Q32137 protects the -50-V Supply if excess current is demanded from this supply. Since the load is connected to this supply through R32139, all current from the -50-Volt Supply must flow through this resistor. Transistor Q32137 senses the voltage drop across R32139. Under normal operation, there is insufficient voltage drop across R32139 to forward bias Q32137. However, when excess current is demanded from the -50-V Series Regulator due to a short circuit or similar malfunction at the output of this supply, the voltage drop across R32139 increases until it is sufficient to forward bias Q32137. The collector current of Q32137 results in a reduction of current through Q32115 and Q32143 to limit the conduction of Q32139. This current limiting protects Q32139 from damage due to excess power dissipation.

Several protection diodes are also included in this circuit. CR32139 prevents the output of this supply from going more positive than about +0.6 volt if it is shorted to a positive supply. VR32121 and CR32123 supply a turn-on voltage for Q32130 to start the -50-Volt Supply when the instrument is first turned on. As soon as the -50-Volt Supply turns on, VR32121 and CR32123 turn off to disconnect the turn-on voltage from Q32130.

-15-Volt Supply

Basic operation of all stages in the -15-Volt Supply is the same as for the -50-Volt Supply. Reference level for this supply is established by divider R3272-R3273 between ground and the -50 V Sense voltage. The divider ratio of R3272-R3273 sets a level of -15 volts at the base of Q3275A. The level on the -50 V Sense line is held stable by the -50-Volt Supply. Any change at the output of the -15-Volt Supply appears at the base of Q3275B as an error signal. The output voltage is regulated in the same manner as described for the -50-Volt Supply. CR3293 limits the output of this supply from going more positive than about +0.6 volt if it is shorted to one of the positive supplies. Diodes CR3274 and CR3275 provide reverse voltage protection for transistors Q3275B and Q3275A respectively.

+5-Volt Supply

Basic operation of the +5-Volt Supply is the same as described for the previous supplies. The reference level for this supply is established by the ground connection at the base of Q3264A. Feedback voltage to the base of Q3264B is provided by divider R3264-R3267 between the -50 V Sense line and the +5 V Sense line. The divider ratio of R3265-R3267 is 10:1 so the base of Q3264B is at zero volt when the supply is operating properly. The level on the -50 V Sense line is held stable by the -50-Volt Supply. Therefore, any change at the output of the +5-Volt Supply appears at the base of Q3264B as an error signal. The

output voltage is regulated in the manner described previously for the -50-Volt Supply. Diode CR3261 limits the output of this supply to about -0.6 volt if it is shorted to one of the negative supplies.

+15-Volt Supply

The +15-Volt Supply operates in the same manner as described for the previous supplies. The ground connection at the base of Q3235A provides the reference for this supply. Feedback voltage to the base of Q3235B is provided through divider R3236-R3239 between the -50 V Sense line and the +15 V Sense line. The divider ratio of R3236-R3239 sets the base of Q3235B at zero volt. Any change in the output level of the +15-Volt Supply appears at the base of Q3235B as an error signal. This results in an opposite change at the collector of Q3235B and at the base of Q3238. This change is connected to the +15-V Series Regulator stage through Q3240 to correct the error in the output voltage.

Diode CR3235 protects Q3235B against negative voltages if the +15-Volt Supply is shorted to ground. Diode CR3241 limits the output of this supply to about -0.6 volt if it is shorted to one of the negative supplies.

+50-Volt Supply

Operation of the +50-Volt Supply is the same as described previously for the other supplies. Reference voltage for this supply is established by the ground connection through R3206 at the base of Q3209. Feedback voltage to the base of Q3209B is provided by divider R3208-R3214 between the -50 V Sense line and the +50 V Sense line. The divider ratio of R3208-R3214 sets the base level of Q3209B at zero volt when the output of this supply is correct. The protection diodes in this circuit operate similarly to the other supplies.

READOUT SYSTEM



INTRODUCTION TO READOUT SYSTEM

General

The Readout System provides alpha-numeric display of information encoded by the plug-in units. This display is presented on the CRT and is written by the CRT beam on a time-shared basis with the analog waveform display.

The definition of several terms follows:

Character—A character is a single number, letter, or symbol displayed on the CRT, either alone or in combination with other characters.

Circuit Description—7704A Service

Word—A word is made up of a related group of characters. In the 7704A Readout System, a word can consist of up to ten characters.

Frame—A frame is a display of all words for a given operating mode and plug-in combination. Up to eight words can be displayed in one frame. Figure 2-32 shows the position of each word in a complete frame.

Column—One of the vertical lines in the Character Selection Matrix (see Fig. 2-33). Columns C-0 (column zero) to C-10 (column 10) can be addressed in the 7704A system.

Row—One of the horizontal lines in the Character Selection Matrix. Rows R-1 (row 1) through R-10 (row 10) and R-14 (row 14) can be addressed in the 7704A system.

Time-Slot—A location in a pulse train. In the 7704A Readout System, the pulse train consists of 10 negative-going pulses. Each time-slot pulse is assigned a number between one and ten. For example, the first time-slot is TS-1.

Time-multiplexing—Transmission of data from two or more sources over a common path by using different time intervals for different signals.

Display Format

Up to eight words of readout information can be displayed on the CRT. The position of each word is fixed and is directly related to the plug-in unit from which it originated. Figure 2-32 shows the area of the graticule where the readout from each plug-in unit is displayed. Notice that Channel 1 of each plug-in unit is displayed within the top division of the CRT and Channel 2 is displayed directly below within the bottom division. Figure 2-34 shows a typical display where only Channel 1 of the Right Vertical and B Horizontal units is selected for display.

Each word in the readout display can contain up to 10 characters, although the typical display will contain between two and seven characters per word. The characters are selected from the Character Selection Matrix shown in Fig. 2-33. Any one of the 50 separate characters can be addressed and displayed on the CRT. In instruments above serial number B050000, a decimal-point character can be addressed and displayed. In addition, 12 operational addresses are provided for special instructions to the Readout System. The unused locations in the Matrix (shaded area) are available for future expansion of the Readout System. The method of addressing the locations in the Character Selection Matrix is described in the following discussion.

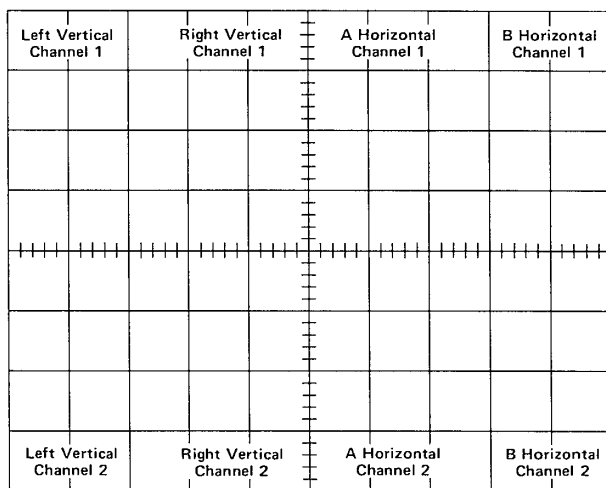

Fig. 2-32. Location of readout words on the CRT identifying the originating plug-in and channel (one complete frame shown, simulated readout).

Developing the Display

The following basic description of the Readout System uses the block diagram shown in Fig. 2-35. This description is intended to relate the basic function of each stage to the operation of the overall Readout System. Detailed information on circuit operation is given later.

The key block in the Readout System is the Timer stage. This stage produces the basic signals which establish the timing sequences within the Readout System. Period of the timing signal is about 250 microseconds (drops to about 210 microseconds when Display-Skip is received; see detailed description of Timing stage for further information). This stage also produces control signals for other stages within this circuit and interrupt signals to the Vertical Interface, Horizontal Interface, and CRT Circuit, which allow a readout display to be presented. The Time-Slot Counter stage receives a trapezoidal voltage signal from the Timer stage and directs it to one of ten output lines. These output lines are labeled TS-1 through TS-10 (time-slots one through ten) and are connected to the vertical and horizontal plug-in compartments as well as to various stages within the Readout System. The output lines are energized sequentially, so there is a pulse on only one of the 10 lines during any 250-microsecond timing period. After the Time-Slot Counter stage has counted time-slot 10, it produces an End-of-Word pulse which advances the system to the next channel.

Two output lines, row and column, are connected from each channel of the plug-in unit back to the Readout System. Data is typically encoded on these output lines by connecting resistors between them and the time-slot input lines. The resultant output is a sequence of ten analog current levels which range from zero to one milliampere (100 microamperes/step) on the row and column output

Column Number →		C-0 to C-10										
↑ Row Number	Current (Milli-amperes)	0	0.1	0.2	0.3	0.4	0.5	0.6	0.7	0.8	0.9	≥1.0
R-1	0	← SKIP ¹ →										
R-2	0.1	0	1	2	3	4	5	6	7	8	9	
R-3	0.2	Add ¹ one zero	Add ¹ two zeros	Shift ¹ prefix ←→	Shift ¹ prefix and add one zero	X	K	M	G	T		IDENTIFY ¹
R-4	0.3	m	μ	n	p	X	K	M	G	T	R	
R-5	0.4	S	V	A	W	H	d	B	c	Ω	E	
R-6	0.5	U	N	L	Z	Y	P	F	J	Q	D	
R-7	0.6			Decimal ¹ point location No. 3	Decimal ¹ point location No. 4	Decimal ¹ point location No. 5	Decimal ¹ point location No. 6	Decimal ¹ point location No. 7				
R-8	0.7											
R-9	0.8											
R-10	0.9	Add Space In Display ¹										

Fig. 2-33. Character Selection Matrix for 7704A Readout System.

Unused locations. Available for future expansion of Readout System

¹ Operational address.

² Decimal point character, instruments serial number B050000 and up. See Decimal-Point Character description in text.

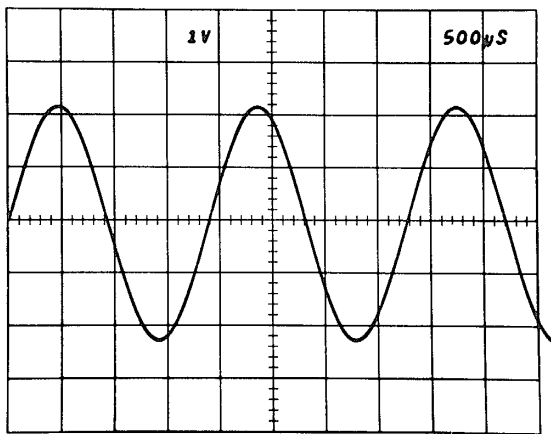

Fig. 2-34. Typical readout display where only channel 1 of the Right Vertical and B Horizontal units is displayed.

lines. This row and column correspond to the row and column of the Character Selection Matrix in Fig. 2-33. The standard format for encoding information onto the output lines is given in Table 2-2. (Special purpose plug-in units may have their own format for readout; these special formats will be defined in the manuals for these units.)

TABLE 2-2
Standard Readout Format

Time-Slot Number	Description
TS-1	Determines decimal magnitude (number of zeros displayed or prefix change information) or the IDENTIFY function (no display during this time-slot).
TS-2	Indicates normal or inverted input (no display for normal).
TS-3	Indicates calibrated or uncalibrated condition of plug-in variable control (no display for calibrated condition).
TS-4	Scaling.
TS-5 TS-6 TS-7	Not encoded by plug-in unit. Left blank to allow addition of zeros by Readout System.
TS-8	Defines the prefix which modifies the units of measurement.
TS-9 TS-10	Define the units of measurement of the plug-in unit. May be standard units of measurement (V, A, S, etc.) or special units selected from the Character Selection Matrix.

The encoded column and row data from the plug-in units is selected by the Column Data Switch and Row Data

Switch stages respectively. These stages take the analog currents from the eight data lines (two channels from each of the four plug-in compartments) and produce a time-multiplexed analog voltage output containing all of the column or row information from the plug-ins. The Column Data Switch and Row Data Switch are sequenced by the binary Channel Address Code from the Channel Counter. The output of the data switches can be disconnected by an input from the Main Interconnect while the Main Interconnect provides the column and row data to the remainder of the Readout System.

The time-multiplexed output of the Column Data Switch is monitored by the Display-Skip Generator to determine if it represents valid information that should be displayed. Whenever information is not encoded in a time-slot, the Display-Skip Generator produces an output level to prevent the Timer stage from producing the control signals that normally interrupt the CRT display and present a character.

The analog outputs of the Column Data Switch and Row Data Switch are connected to the Column Decoder and Row Decoder stages respectively. These stages sense the magnitude of the analog voltage input and produce an output current on one of ten lines. The outputs of the Column Decoder stage are identified as C-1 through C-10 (column 1 through 10) corresponding to the encoded column information. Likewise, the outputs of the Row Decoder stage are identified as R-1 through R-10 (row 1 through 10) corresponding to the encoded row information. The primary function of the row and column outputs is to select a character from the Character Selection Matrix to be produced by the Character Generator stage. These outputs are also used at other points within the system to indicate when certain information has been encoded. One such stage is the Zeros Logic and Memory. During time-slot 1 (TS-1), this stage checks if zero-adding or prefix-shifting information has been encoded by the plug-in unit, and stores it in memory until time-slots 5, 6, or 8. After storing this information, it triggers the Display-Skip Generator stage so that there is no display during time-slot 1 (as defined by Standard Readout Format; see Table 2-2). When time-slots 5, 6, and 8 occur, the memory is addressed and any information stored there during time-slot 1 is transferred to the input of the Column Decoder stage to modify the analog data during the applicable time-slot.

Also, the Zeros Logic and Memory stage produces the IDENTIFY function. When time-slot 1 is encoded for IDENTIFY (column 10, row 3), this stage produces an output level, which connects the Column Data Switch and Row Data Switch to a coding network within the Readout System. Then, during time-slots 2 through 9, an analog current output is produced from the Column Data Switch and Row Data Switch which addresses the correct points in the Character Selection Matrix to display the word "IDENTIFY" on the CRT. The Zeros Logic and Memory stage is reset after each word by the Word Trigger pulse.

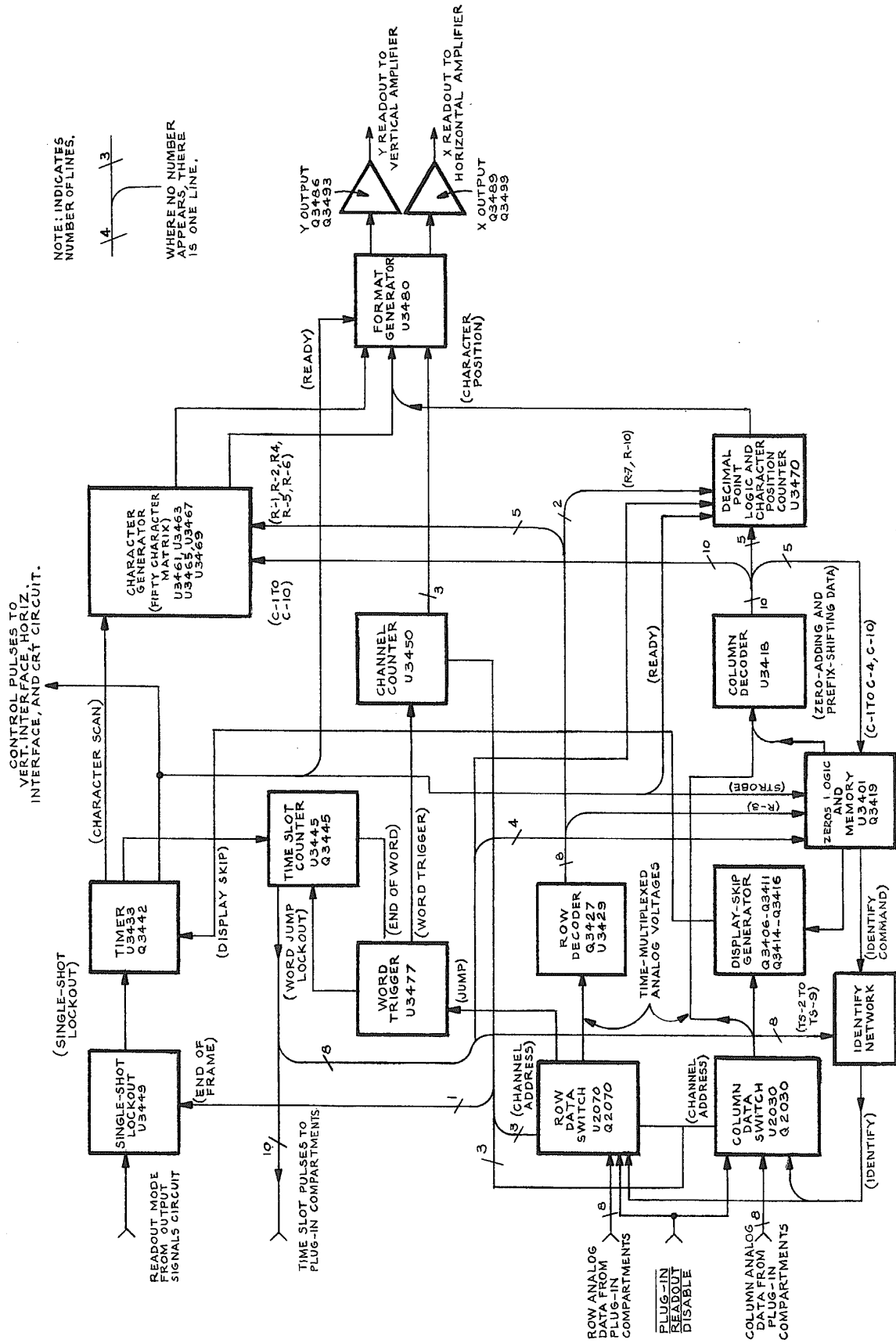

NOTE: INDICATES NUMBER OF LINES.
 WHERE NO NUMBER APPEARS THERE IS ONE LINE.

Fig. 2-35. Detailed block diagram of Readout System.

Circuit Description—7704A Service

The Character Generator stages produce the characters which are displayed on the CRT. Any of the 50 characters shown on the Character Selection Matrix of Fig. 2-33 can be addressed by proper selection of the column and row currents. Only one character is addressable in any one time-slot; a space can be added into the displayed word by the Decimal Point Logic and Character Position Counter stage when encoded by the plug-in. The latter stage counts the number of characters generated and produces an output current to step the display one character position to the right for each character. In addition, the character position is advanced once during each of time-slots 1, 2, and 3, whether a character is generated during these time-slots or not. This action fixes the starting point of the standard-format display such that the first digit of the scaling factor always starts at the same point within each word regardless of the information encoded in time-slot 1, 2, or 3 preceding this digit. Also, by encoding row 10 and column 0 during any time-slot, a blank space can be added to the display. Decimal points can be added to the display at any time by addressing the appropriate row and column (see Character Selection Matrix for location of these decimal points). The Decimal Point Logic and Character Position Counter stage is reset after each word by the Word Trigger pulse.

The Format Generator stage provides the output signals to the vertical and horizontal deflection systems of the instrument to produce the character display. The binary Channel Address Code from the Channel Counter stage is connected to this stage, so that the display from each channel is positioned to the area of the CRT associated with the plug-in and channel originating the word (see Fig. 2-32). The positioning current or decimal point location current generated by the Decimal Point Logic and Character Position Counter stage is added to the Horizontal (X) signal at the input to the Format Generator stage to provide horizontal positioning of the characters within each word. The X- and Y-Readout signals are connected to the Horizontal Amplifier and Vertical Amplifier through the X- and Y-Buffer stages.

The Word Trigger stage produces a trigger from the End-of-Word pulse generated by the Time-Slot Counter stage after the tenth time-slot. This Word Trigger pulse advances the Channel Counter to display the information from the next channel or plug-in. It also provides a reset pulse to the Zeros Logic and Memory stage and the Decimal Point Logic and Character Position Counter stage. The Word Trigger stage can also be advanced to jump a complete word or a portion of a word when a Jump command is received from the Row Data Switch stage.

The Single-Shot Lockout stage allows the display sequence of the Readout System to be changed. Normally,

the Readout System operates in a free-running mode, so the waveform display is interrupted randomly to display characters. However, under certain conditions (such as single-shot photography), it is desirable that the Readout System operate in a triggered mode where the readout portion of the display is normally blanked out, but can be presented on command. The Readout Mode input from the Output Signals circuit determines the operating mode of the Readout System.

Circuit Analysis of Readout System

The following analysis of the Readout System discusses the operation of each stage in detail. A complete schematic of the Readout System is shown on diagram 10 at the rear of this manual.

Timer

Timer U3433 establishes the timing sequence for all circuits within the Readout System. This stage produces seven time-related output waveforms (see Fig. 2-36). The triangle waveform produced at pin 6 forms the basis for the remaining signals. The basic period of this triangle waveform is about 250 microseconds as controlled by RC network C3434-R3434. The triangle waveform is clipped and amplified by U3433 to form the trapezoidal output signal at pin 10. The amplitude of this output signal is exactly 15 volts as determined by U3433 (exact amplitude necessary to accurately encode data in plug-in units; see Encoding the Data). The Trigger output at pin 5 provides the switching signal for the Time-Slot Counter and Word Trigger stages.

The signals at pins 12, 13, 14, and 16 are produced only when the triangle waveform is on its negative slope and the trapezoidal waveform has reached the lower level. The timing sequence of these waveforms is important to the operation of the Readout System (see expanded waveforms in Fig. 2-37). The Z-Axis Inhibit at pin 14 is produced first. This negative-going signal provides a blanking pulse to the CRT Circuit (see diagram 14) to blank the CRT before the display is switched to the Readout System. It also produces the Strobe pulse through Q3442 and CR3442 to signal other stages within the Readout System to begin the sequence necessary to produce a character. The collector level of Q3442 is also connected to Character Generator No. 2, U3463, through CR3443. This activates U3463 during the quiescent period of the Strobe pulse (collector of Q3442 negative) and diverts the output current of Row Decoder U3429 to row 2. The purpose of this configuration is to prevent the Zeros Logic and Memory stage U3401 from storing incorrect data during the quiescent period of the Strobe pulse. When the Strobe pulse goes positive, CR3443 is reverse-biased to disconnect Q3442 from U3463 and allow the Row Decoder to operate in the normal manner.

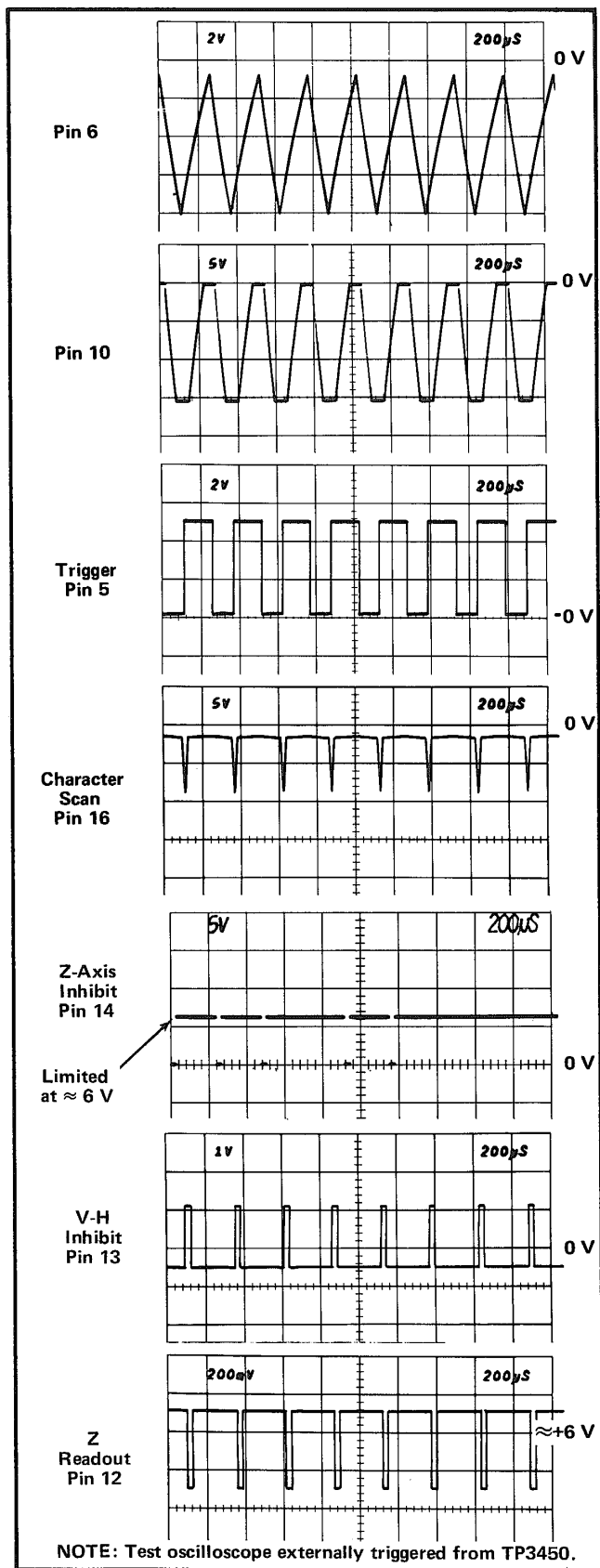

Fig. 2-36. Output waveforms of Timer stage.

The next signal to be produced is the V-H (Vertical-Horizontal) Inhibit at pin 13. This positive-going signal disconnects the plug-in signals from the vertical and horizontal deflection systems so the plug-in units do not control the position of the CRT beam during the readout display. The Ready signal derived from this output is connected to the Decimal Point Logic and Character Position Counter stage and the Format Generator stage.

The Z Readout output at pin 12 is produced next. This current is connected to the CRT Circuit to unblank the CRT to the intensity level determined by the READOUT intensity control. The Character Scan ramp at pin 16 started to go negative as this timing sequence began. However, character generation does not start until the readout intensity level has been established. The triangular Character Scan ramp runs from about -2 volts to about -8.5 volts, then returns back to the original level. This waveform provides the scanning signal for the Character Generator stages. Full Character Scan adjustment R3437 sets the DC level of the Character Scan ramp for complete characters on the display.

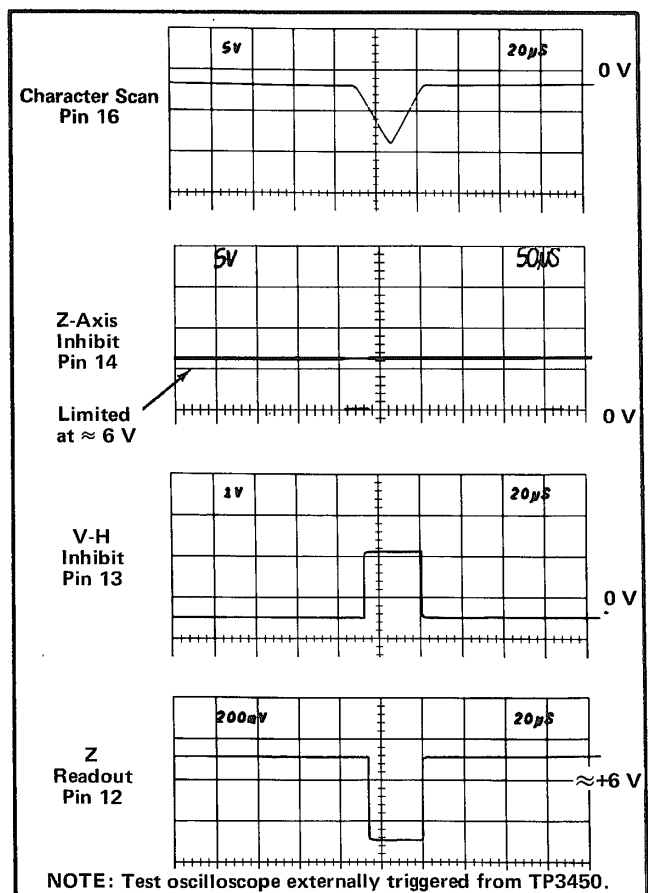

Fig. 2-37. Detail of output at pins 12, 13, 14, and 16 of U3433.

Circuit Description—7704A Service

The Timer stage operates in one of two modes as controlled by the Display-Skip level at pin 4. The basic mode just described is a condition that does not occur unless all ten characters of each word (80 characters total) are displayed on the CRT. Under typical conditions only a few characters are displayed in each word. The Display-Skip level at pin 4 determines the period of the Timer output signal. When a character is to be generated, pin 4 is LO and the circuit operates as just described. However, when a character is not to be displayed, a HI level is applied to pin 4 of U3433 through CR3432 from the Display-Skip Generator stage. This signal causes the Timer to shorten its period of operation to about 210 microseconds. The waveforms in Fig. 2-38 show the operation of the Timer stage when the Display-Skip condition occurs for all positions in a word. Notice that there is no output at pins 12, 13, 14, and 16 under this condition. This means that the CRT display is not interrupted to display characters. Also notice that the triangle waveform at pin 6 does not go as far negative, and that the negative portion of the trapezoidal waveform at pin 10 is shorter. Complete details on operation of the Display-Skip Generator are given later.

The Timer operation is also controlled by the Single-Shot Lockout level at pin 2. If this level is LO, the Timer operates as just described. However, if the Single-Shot Lockout stage sets a HI level at this pin, the Timer stage is locked out and can not produce any output signals (see Single-Shot Lockout description for further information).

READOUT intensity control R5006 (see diagram 11) sets the intensity of the readout display independently of the A or B INTENSITY controls. The READOUT intensity control also provides a means of turning the Readout System off when a readout display is not desired. When R5006 is turned fully counterclockwise, switch S5006 opens. The current to pin 11 of U3433 is interrupted, and at the same time, a positive voltage is applied to pin 4 through CR3431. The positive voltage switches the stage to the same conditions as were present under the Display-Skip condition. Therefore, the CRT display is not interrupted to present characters. However, time-slot pulses continue to be generated.

Time-Slot Counter

Time-Slot Counter U3445 is a sequential switch which directs the trapezoidal waveform input at pin 8 to one of its 10 output lines. These time-slot pulses are used to interrogate the plug-in units to obtain data for the Readout System. The Trigger pulse at pin 15 switches the Time-Slot Counter to the next output line; the output signal is sequenced consecutively from time-slot 1 through time-slot 10. Figure 2-39 shows the time relationship of the time-slot pulses. Notice that only one line carries a time-slot pulse at any given time. When time-slot 10 is completed, a negative-

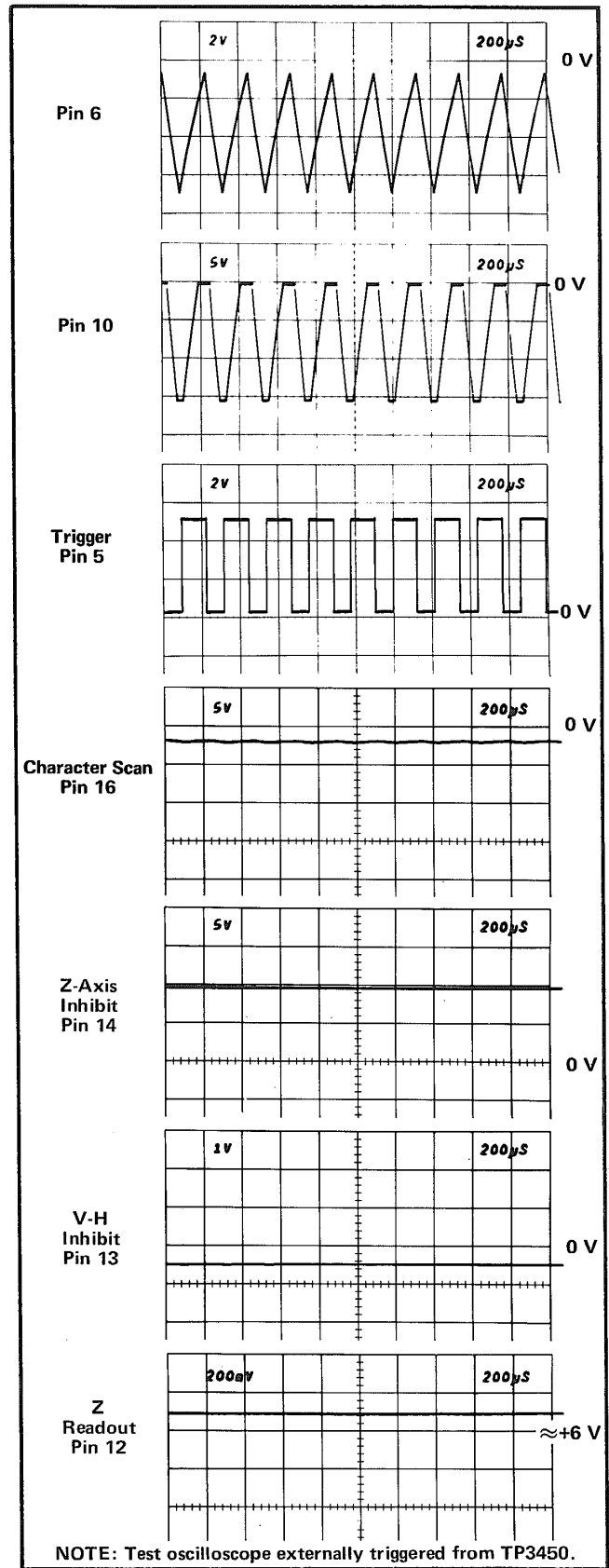

Fig. 2-38. Timer stage operation when Display-Skip condition occurs.

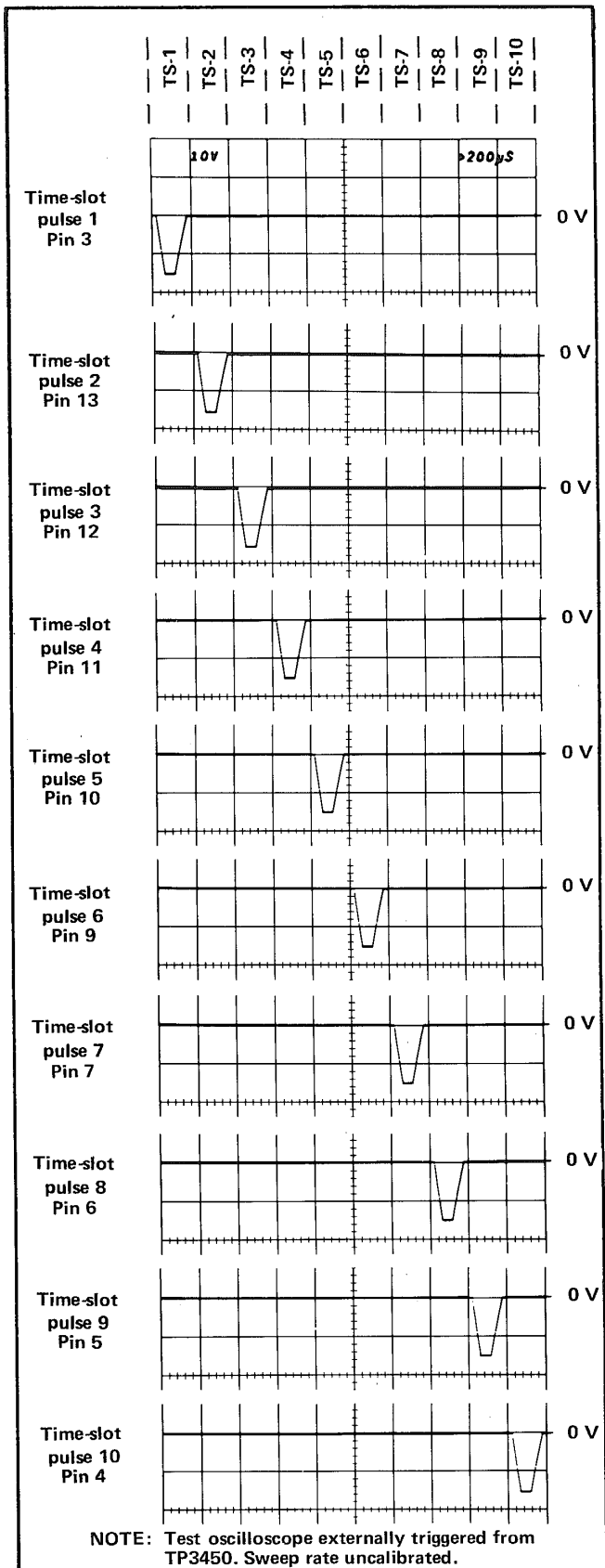

Fig. 2-39. Time relationship of the time-slot (TS) pulses produced by U3445.

going End-of-Word pulse is produced at pin 2. The End-of-Word pulse provides a drive pulse for the Word Trigger stage and also provides an enabling level to the Display-Skip Generator during time-slot 1 only.

Pin 16 is a reset input for the Time-Slot Counter. When this pin is held LO, the Time-Slot Counter resets to time-slot 1. The Time-Slot Counter can be reset in this manner only when a Jump Command is received by U3447A and B (see following discussion).

Word Trigger

The Word Trigger stage is made up of U3447. Quiescently, pin 8 of U3447C is LO as established by the operating conditions of U3447A-U3447B. Therefore, the LO End-of-Word pulse produced by the Time-Slot Counter results in a HI level at pin 10 of U3447C. This level is inverted by U3447D to provide a negative-going Word Trigger pulse to the Channel Counter.

A Word Trigger pulse is also produced by U3447D when a Jump Command is received at pin 5 of U3447B. This condition can occur during any time-slot (see Row Decoder for further information on origin of the Jump Command). U3447B and U3447A are connected as a bistable flip-flop. The positive-going Jump Command at pin 5 of U3447B produces a LO at pin 4. This LO is inverted by U3447A to produce a HI at pin 1, which allows pin 6 to be pulled HI through CR3447. The flip-flop has now been set and remains in this condition until reset, even though the Jump Command at pin 5 returns to its LO level. The HI output level at pin 1 turns on Q3445 to pull pin 16 of the Time-Slot Counter LO. This resets the Time-Slot Counter to time-slot 1 and holds it there until the Word Trigger is reset. At the same time, a HI level is applied to pin 4 of the Timer through CR3445 and CR3432. This HI level causes the Timer to operate in the Display-Skip mode, so a character is not generated.

The next Trigger pulse is not recognized by the Time-Slot Counter, since U3445 is locked in time-slot 1 by U3447. However, this Trigger pulse resets the Word Trigger stage through C3445. Pin 1 of U3447A goes LO to enable the Time-Slot Counter and Timer stages for the next time-slot pulse. Simultaneously, when U3447A switches output states, the resulting negative-going edge is connected to pin 8 of U3447C. This results in a negative-going Word Trigger output at pin 13 to advance the Channel Counter to the next word. When the next Trigger pulse is received at pin 15, the Time-Slot Counter returns to the normal sequence of operation and produces an output on the time-slot 1 line.

Channel Counter

Channel Counter U3450 is a binary counter which produces the Channel Address Code for the Column and Row Decoder stages and the Format Generator stage. This code instructs these stages to sequentially select and display the eight channels of data from the plug-ins. Table 2-3 gives the eight combinations of the Channel Address Code and the resultant channel selected with each combination.

TABLE 2-3
Channel Address Code

Pin 11 U3450	Pin 8 U3450	Pin 9 U3450	Channel Displayed
LO	LO	LO	Channel 2 Left Vertical
LO	LO	HI	Channel 1 Left Vertical
LO	HI	LO	Channel 2 Right Vertical
LO	HI	HI	Channel 1 Right Vertical
HI	LO	LO	Channel 2 A Horizontal
HI	LO	HI	Channel 1 A Horizontal
HI	HI	LO	Channel 2 B Horizontal
HI	HI	HI	Channel 1 B Horizontal

Single-Shot Lockout

U3449 makes up the Single-Shot Lockout stage. This stage allows a single readout frame (eight complete words) to be displayed on the CRT, after which the Readout System is locked out, so further readout displays are not presented until the circuit is reset. U3449C and U3449D are connected to form a bistable flip-flop. For normal operation, pin 8 of U3449C is pulled HI through R3449. This activates U3449C to result in a LO output level at pin 10, enabling the Timer stage to operate in the free-running manner described previously.

The output of the Single-Shot Lockout stage remains LO to allow U3433 to operate in the free-running mode until a LO is received at pin 8 of U3449C. When this occurs, the output level at pin 10 of U3449C does not change immediately. However, the Readout System is now enabled as far as the single-shot lockout function is concerned. If the Channel Counter has not completed word eight (Channel 1 of B Horizontal unit), the Readout System continues to operate in the normal manner. However, when word eight is completed, the positive-going End-of-Frame pulse is produced at pin 11 of U3450 as the Channel

Counter shifts to the code necessary to display word one. This pulse is coupled to pin 12 of U3449D. The momentary HI at pin 12 activates U3449D and its output goes LO to disable U3449C (pin 8 already LO). The output of U3449C goes HI to disable the Timer, so it operates in the Display-Skip mode. The HI at pin 10 of U3449C also holds U3449D enabled, so it maintains control of the flip-flop.

The Single-Shot Lockout stage remains in this condition until a positive-going trigger pulse is applied to pin 8 of U3449C. This trigger pulse produces a LO at pin 10 of U3449C to enable U3433 and disable U3449D. Now, the Timer can operate in the normal manner for another complete frame. When word eight is completed, the Channel Counter produces another End-of-Frame pulse to again lock out the Timer stage. (For further information on the Readout Mode, see the Output Signals description.)

Encoding the Data

Data is conveyed from the plug-in units to the Readout System in the form of an analog (current level) code. The characters that can be selected by the encoded data are shown on the Character Selection Matrix (see Fig. 2-33). Each character requires two currents to define it; these currents are identified as the column current and the row current, corresponding to the column and row of the matrix. The column and row data is encoded by programming the plug-in units. Figure 2-40 shows a typical encoding scheme using resistors for a voltage-sensing amplifier plug-in unit. Notice that the 10 time-slot (TS) pulses produced by the Time-Slot Counter stage are connected to the plug-in unit. However, time-slots 5, 6, 7, and 10 are not used by the plug-in unit to encode data when using the Standard Readout Format (see Table 2-2 for Standard Readout Format). The amplitude of the time-slot pulses is exactly -15 volts as determined by the Timer stage. Therefore, the resultant output current from the plug-in units can be accurately controlled by the programming resistors in the plug-in units.

For example, in Fig. 2-40 resistors R10 through R90 control the row analog data, which is connected back to the Readout System. Figure 2-41A shows an idealized output current waveform of row analog data, which results from the time-slot pulses. Each of the row levels of current shown in these waveforms corresponds to 100 microamperes of current. The row numbers on the left-hand side of the waveform correspond to the rows in the Character Selection Matrix (see Fig. 2-33). The row analog data is connected back to the Readout System via terminal B37 of the plug-in interface.

The Column analog data is defined by resistors R110 through R190. The program resistors are connected to the time-slot lines by switch closures to encode the desired data. The data as encoded by the circuit shown in Fig. 2-40

The Column Data Switch U2030 and the Row Data Switch U2070 receive the Channel Address Code from the Channel Counter. This binary code directs the Column Data Switch and the Row Data Switch as to which channel should be the source of the encoding data. Table 2-3 gives the eight combinations of the Channel Address Code and the resultant channel selected with each combination. These stages have nine inputs and provide a

The encoding data from the plug-in units is connected to the Column and Row Data Switch stages. A column-data line and a row-data line convey analog data from each of the eight data sources (two channels from each of the four plug-in compartments).

Column and Row Data Switches

The preceding information gave a typical example of encoding data from an amplifier plug-in unit. Specific encoding data and circuitry is shown in the individual plug-in unit manuals.

Three other lines of information are connected from the plug-in compartments to the Readout System. The column and row analog data from Channel 2 of a dual-channel plug-in are connected to the Readout System through terminals A38 and B38 of the plug-in interface, respectively. Force readout information is encoded on terminal A35; the function of this input is described under Column and Row Data Switches.

Likewise, if a 100X readout-coded probe is connected to the input of the plug-in unit, the column current during time-slot 1 will be increased two units for a total of four units of column current. This addresses an instruction in the Character Selection Matrix to shift the prefix and add one zero to the display. The resultant CRT readout with the previous program is 10 mV.

The column analog data encoded by most plug-in units can be modified by attenuator probes connected to the input connectors of amplifier plug-in units. A special coding ring around the input connector of the plug-in unit senses the attenuation ratio of the probe (with readout-coded probes only). The probe contains a circuit which provides additional column current. For example, if a 10X attenuator probe is connected to a plug-in unit encoded for 100 microvolts as shown in Fig. 2-40, an additional unit of current is added to the column analog data during time-slot 1. Since two units of current were encoded by R111 (see Fig. 2-40), this additional current results in a total of three units of column analog current during this time-slot. Referring to the Character Selection Matrix, three units of column current, along with the two units of row current encoded by R10, indicates that the prefix should be shifted one column to the left. Since this instruction occurs in the same time-slot that previously indicated that two zeros should be added to the display and only one instruction can be encoded during a time-slot, the zeros do not appear in the display. The CRT readout will now be changed to 1 mV (readout program produced by plug-in same as for previous example).

Selection Matrix was addressed to obtain information in each time-slot. The column data changes to encode the applicable readout data as the operating conditions change. For example, if the variable control of the plug-in unit was activated, R130 would be connected between time-slot 3 and the column analog data output line. This encodes 10 units of column current (see shaded area in time-slot 3 of the waveform shown in Fig. 2-41B). Since one unit of row current is also encoded during this time-slot by R30, a > symbol is added to the display. The CRT readout will now show $\uparrow > 100 \mu\text{V}$. In a similar manner, the other switches can change the encoded data for the column output and thereby change the readout display. See the descriptions which follow for decoding this information.

Circuit Description—7704A Service

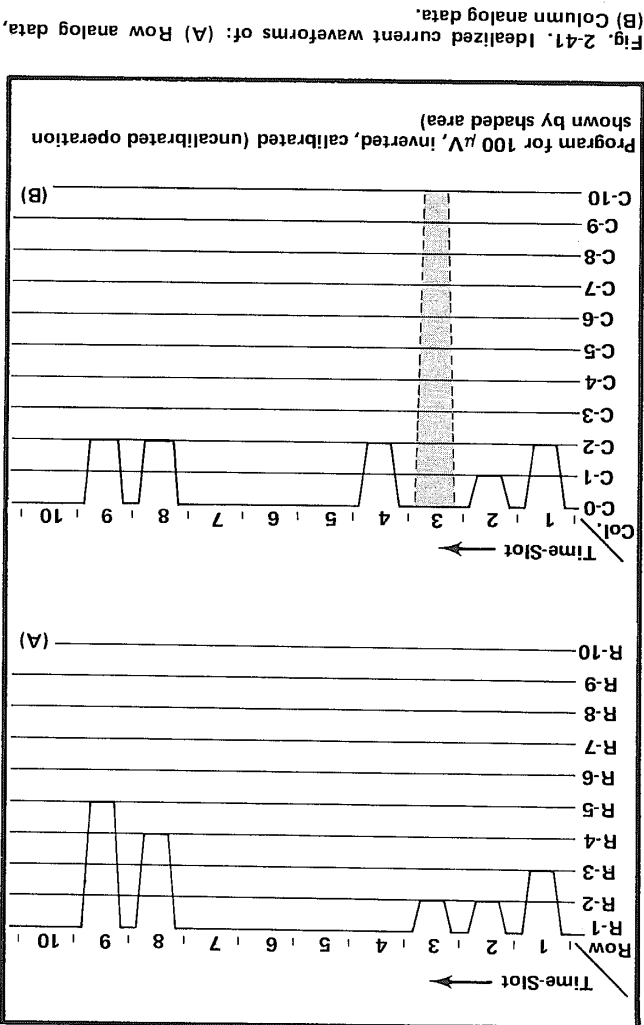

Fig. 2-41. Idealized current waveforms of: (A) Row analog data, (B) Column analog data.

The preceding information gave a typical example of encoding data from an amplifier plug-in unit. Specific encoding data and circuitry is shown in the individual plug-in unit manuals.

Column and Row Data Switches

The encoding data from the plug-in units is connected to the Column and Row Data Switch stages. A column-data line and a row-data line convey analog data from each of the eight data sources (two channels from each of the four plug-in compartments).

The Column Data Switch U2030 and the Row Data Switch U2070 receive the Channel Address Code from the Channel Counter. This binary code directs the Column Data Switch and the Row Data Switch as to which channel should be the source of the encoding data. Table 2-3 gives the eight combinations of the Channel Address Code and the resultant channel selected with each combination. These stages have nine inputs and provide a

Fig. 2-40. Typical encoding scheme for voltage-sensing plug-in unit. Coding shown for deflection factor of 100 microvolts.

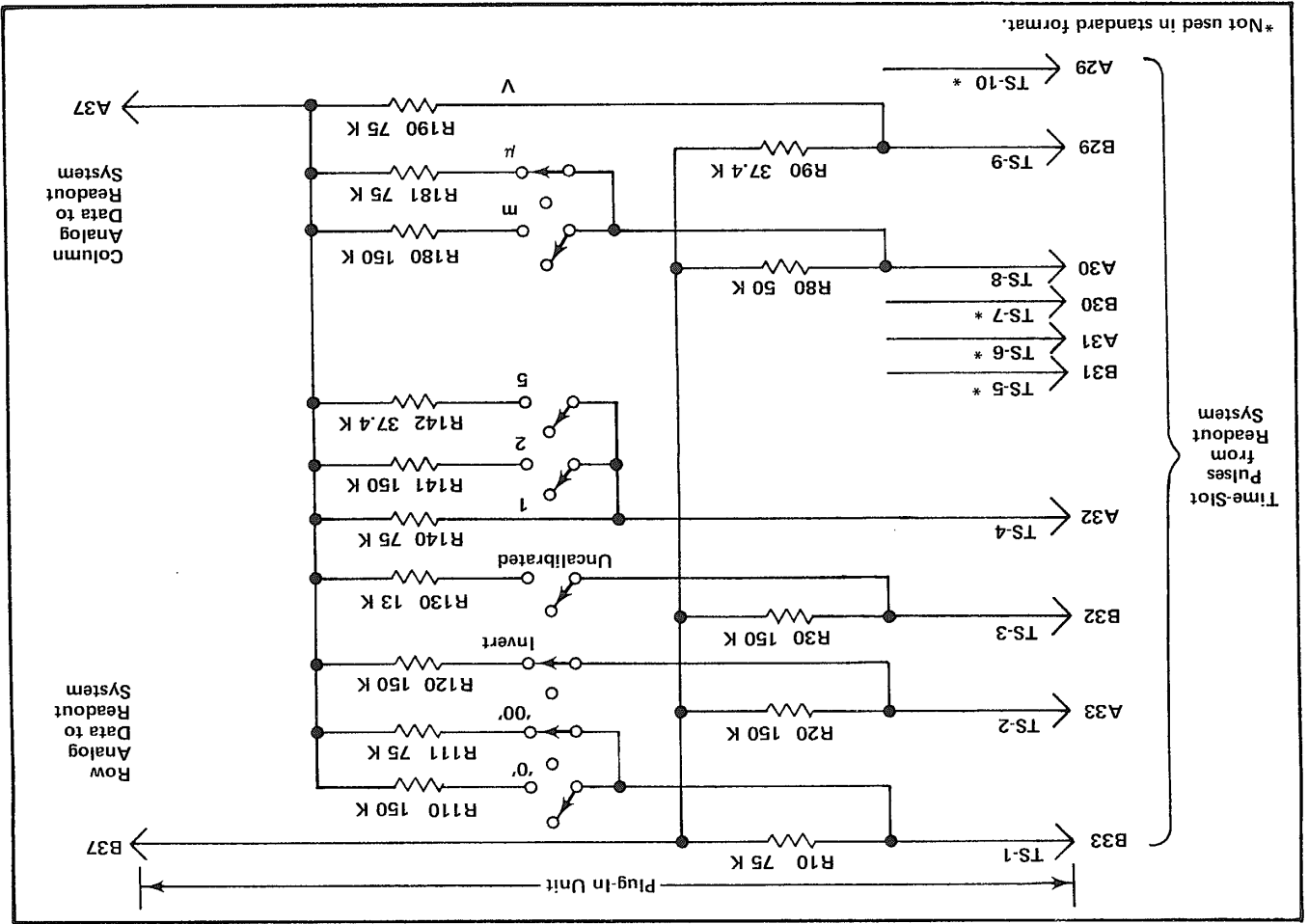

In the above example, the row analog data was programmed to define which row of the Character

The final data output is provided from time-slot 9 by R190 connected to the column output and R90 to the row output. These resistors encode three units of column current and four units of row current to cause a V (volts) to be displayed. Time-slot 10 is not encoded in accordance with the Standard Readout Format. The resultant CRT readout will be $\approx 100 \mu V$.

During time-slot 4, two units of column current are encoded by R140. There is no row current encoded during this time-slot; this results in the numeral 1 being displayed on the CRT. Neither row nor column analog data is encoded during time-slots 5, 6, and 7 as defined by the Standard Readout Format. During time-slot 8, two units of column current and three units of row current are encoded by resistors R181 and R80, respectively. This addresses the μ prefix in the Character Selection Matrix.

Circuit Description-7704A Service

Resistor R111, connected between time-slot 1 and the column analog data output, encodes two units of current during time-slot 1. Referring to the Character Selection Matrix, two units of column current, along with the two units of row current encoded by resistor R10 (row 3), indicates that two zeros should be added to the display. Resistor R120 adds one unit of column current during time-slot 2 and, along with the one unit of current from the row output, the Readout System is instructed to add an invert arrow to the display. Resistor R130 is not connected to the time-slot 3 line, since the vertical deflection factors are calibrated. Therefore, there is no column current output during this time-slot and no display on the CRT (see Display-Skip Generator for further information).

indicates a 100-microvolt sensitivity with the CRT display inverted and calibrated vertical deflection factors. This results in the idealized output current waveforms shown in Fig. 2-41B at the column analog data output, terminal A37 of the plug-in interface.

time-multiplexed output at pin 7, which includes the information from all of the input channels. Eight of the nine inputs to each stage originate in the plug-in units; the ninth input comes from a special data-encoding network composed of resistors R2058 through R2069 and R2070 through R2079 (see Zeros Logic and Memory description for further information on ninth channel).

In addition to the encoding data inputs from the plug-in units, inputs are provided to the Column Data Switch from the VERTICAL MODE and HORIZONTAL MODE switches to inhibit the readout for any plug-in unit(s) not selected for display. When a plug-in unit is selected, the respective mode input is HI to forward bias the associated diodes; CR2031-CR2033, CR2035-CR2037, CR2041-CR2043, or CR2045-CR2047. The forward-biased diodes cause the channel switches to bypass the encoded data from the opposite channel. However, since it may be desired to display information from special-purpose plug-in units (even though they do not produce a normal waveform display on the CRT), a feature is provided to over-ride the mode inhibit. This is done by applying a LO to the associated Force Readout input. The LO level diverts the HI mode-inhibit current and allows the data from this plug-in unit to reach the Column Data Switch, even though it has not been selected for display by the mode switches.

The outputs of U2070 and U2030 are connected to the rest of the Readout System through Q2070 and Q2030, respectively and through the Main Interconnect. Q2070 and Q2030 are normally forward biased by the positive voltage level established at their bases by divider R2051-CR2051-R2053. The Plug-In Readout Disable level from the Main Interconnect goes LO to reverse-bias CR2051-Q2030-Q2070. This disconnects U2030 and U2070 from the Readout System to allow the Main Interconnect to provide time-multiplexed analog voltages for the readout display.

Row Match adjustment R3422 sets the gain of the Row Data Switch to match the gain of the Row Decoder for correct output. Column Match adjustment R3407 performs the same function for the Column Data Switch stage.

Display-Skip Generator

The Display-Skip Generator is made up of Q3406, Q3411, Q3414, and Q3416. This stage monitors the time-multiplexed column data at the output of the Column Data Switch during each time-slot to determine if the information at this point is valid data that should result in a CRT display. Quiescently, there is about 100 microamperes of current flowing through R3407 from Q3419 and the Zeros Logic and Memory stage. (The purpose of this quiescent current will be discussed in connection with the Zeros Logic and Memory stage.) This current biases Q3406A so that its base is about 0.2 volt more positive

than the base of Q3406B in the absence of column data. Therefore, since Q3406A and Q3406B are connected as a comparator, Q3406A will remain on unless its base is pulled more negative than the base of Q3406B.

The analog data output from the Column Data Switch produces a 0.5-volt (approximately) change for each unit of column current that has been encoded by the plug-in unit. Whenever any information appears at the output of the Column Data Switch, the base of Q3406A is pulled more negative than the base of Q3406B, resulting in a negative (LO) Display-Skip output to the Timer stage through Q3416. Recall that a LO was necessary at the skip input of the Timer so it could perform the complete sequence necessary to display a character.

Q3411-Q3414 also provide Display-Skip action. The End-of-Word level connected to their emitters is LO only during time-slot 1. This means they are enabled only during this time-slot. These transistors allow the Zeros Logic and Memory stage to generate a Display-Skip signal during time-slot 1 when information that is not to be displayed on the CRT has been stored in memory (further information is given under Zeros Logic and Memory description).

Column and Row Decoders

The Column Decoder U3418 and Row Decoder U3429 sense the magnitude of the analog voltages at their inputs (pin 10) and produce a binary output on one of ten lines corresponding to the column or row data encoded by the plug-in unit. These outputs provide the Column Digital Data and Row Digital Data, which is used by the Character Generator stages to select the desired character for display on the CRT. The column and row data is also used throughout the Readout System to perform other functions.

The input current at pin 9 of the Column Decoder stage is steered to only one of the ten Column Digital Data outputs. The size of the displayed character is determined by the value of R3418. When a Display-Skip signal is present (collector of Q3416 HI), pin 9 is pulled HI through CR3416. This ensures that no current is connected to the Character Generator stage under this condition. Notice the corresponding input on the Row Decoder. This input is connected to ground and causes only one of the ten row outputs to saturate to ground.

The network at the input of the Row Decoder, made up of Q3427 and its associated components, is a Row-14 detector which produces the Jump Command. This row current is encoded by special-purpose plug-ins to cause all or part of a word to be jumped. Whenever row 14 (thirteen units of row current, 1.3 milliamperes) is encoded, the base of Q3427 is pulled negative enough so that this transistor is reverse biased to produce a HI Jump Command output at

its collector. This Jump Command is connected to the Word Trigger stage to advance the Channel Counter to the next word and to reset the Time-Slot Counter to time-slot 1.

Zeros Logic and Memory

The Zeros Logic and Memory stage U3401 stores data encoded by the Plug-in units to provide zeros-adding and prefix-shifting logic for the Readout System. The Strobe pulse at pin 15 goes positive when the data has stabilized and can be inspected. This activates the Zeros Logic and Memory stage so that it can store the encoded data. A block representation of the memory sequence is shown in Fig. 2-42.

Typical output waveforms for the five possible input conditions that can occur are shown in Fig. 2-43. When time-slot 1 occurs, a store command is given to all of the memories. If the plug-in unit encoded data for column 1, 2, 3, 4, or 10 during time-slot 1, the appropriate memory (or memories) is set. Notice that row 3 information from the Row Decoder must also be present at pin 16 for data to be stored in the memory of U3401.

If data was encoded during time-slot 1, a negative-going output is produced at pin 7 while the memories are being set. This negative-going pulse is connected to the base of Q3414 in the Display-Skip Generator to produce a Display-Skip output. Since the information encoded during time-slot 1 was only provided to set the memories and not intended to be displayed on the CRT at this time, the Display-Skip output prevents a readout display during this time-slot.

During time-slot 5, memory A is interrogated. If information was stored in this memory, a positive-going output is produced at pin 7. This pulse is connected to pin 10 of the Column Decoder through Q3419 to add one unit of current at the input of the Column Decoder. This produces a zero after the character displayed during time-slot 4. During time-slot 6, memory B is interrogated to see if another zero should be added. If another zero is necessary, a second positive output is produced at pin 7, which again results in a column 1 output from the Column Decoder and a second zero in the CRT display.

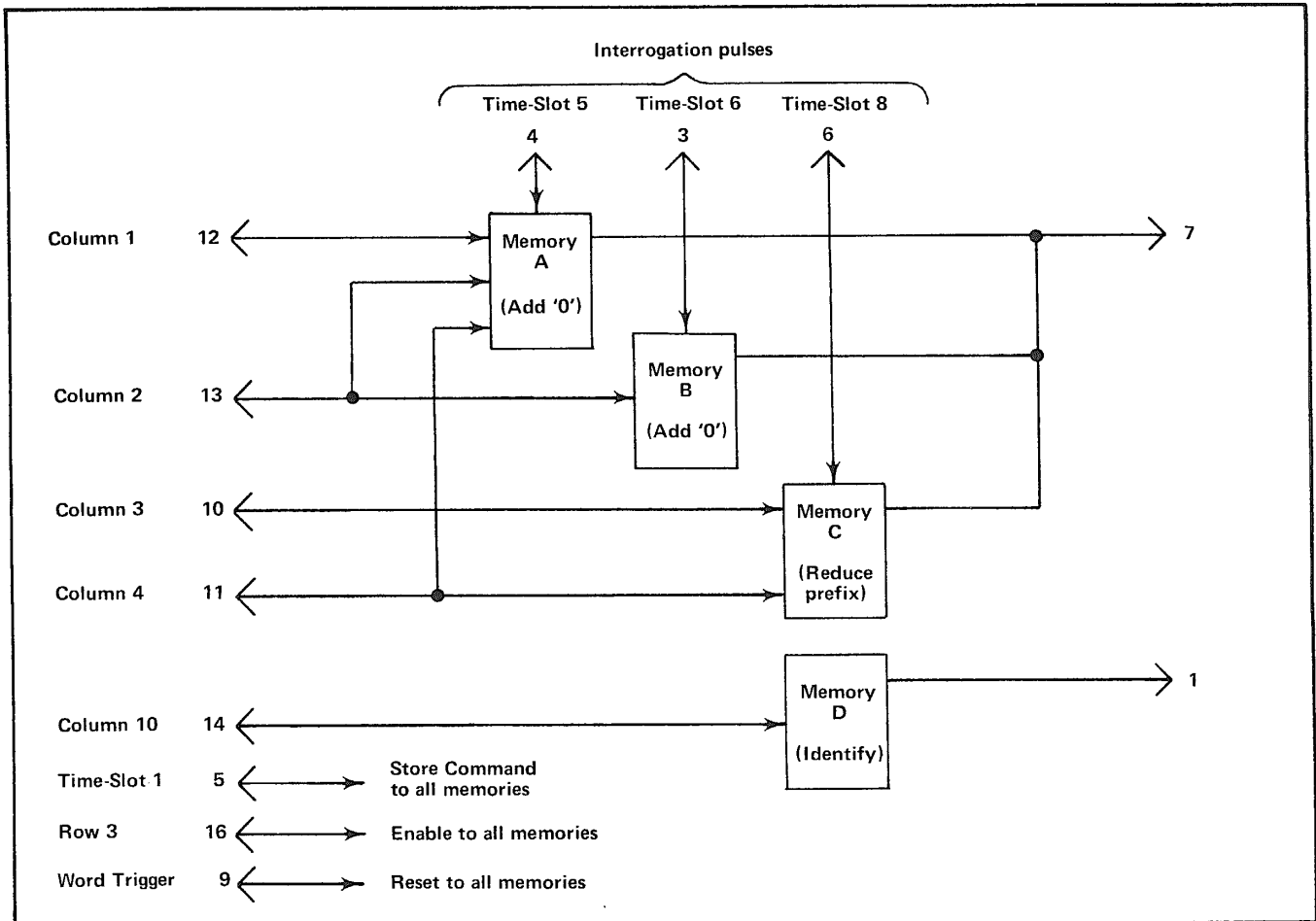

Fig. 2-42. Block representation of memory sequence in U3401.

Finally, memory C is interrogated during time-slot 8 to obtain information on whether the prefix should be changed, or left at the value that was encoded. If data has been encoded that calls for a shift in prefix, a negative-going output level is produced at pin 7. This negative level subtracts one unit of column current from the data at the input to the Column Decoder. Notice on the Character Selection Matrix of Fig. 2-33 that when row 4 is programmed, a reduction of one column results in a one-column shift of the prefix. For example, with the 100 μ V program shown in Fig. 2-40, if the data received from the plug-in called for a shift in prefix, the CRT readout would be changed to 1 mV (zeros deleted by program; see Encoding the Data).

The 100 microamperes of quiescent current through R3407 provided by Q3419 (see Display-Skip Generator) allows the prefix to be shifted from m (100 microamperes column current, column 1) to no prefix (zero column current, column zero) so only the unit of measurement encoded during time-slot 9 is displayed. Notice that reducing the prefix program from column 1 to column 0 programs the Readout System to not display a character at this readout location.

A further feature of the Zeros Logic and Memory is the Identify function. If 10 units of column current are encoded by the plug-in unit along with row 3 during time-slot 1, the Zeros Logic and Memory produces a negative-going output pulse at pin 1 to switch the Column Data Switch and Row Data Switch to the ninth channel. Then, time-slot pulses 2 through 9 encode an output current through resistors R2058-R2069 for column data and R2070-R2079 for row data. This provides the currents necessary to display the word IDENTIFY in the word position allotted to the channel that originated the Identify command. After completion of this word, the Column Data Switch and Row Data Switch continue with the next word in the sequence.

The Word Trigger signal from the Word Trigger stage is connected to pin 9 of U3401 through C3401. At the end of each word of readout information, this pulse goes LO. This erases the four memories in the Zeros Logic and Memory in preparation for the data to be received from the next channel.

Character Generators

The Character Generator stage consists of five similar integrated circuits (U3461 through U3469), which generate the X (horizontal) and Y (vertical) outputs at pins 16 and 1, respectively, to produce the character display on the CRT. Each integrated circuit can produce 10 individual characters. U3461 (designated "Numerals") can produce the numerals 0 through 9 shown in row 1 of the Character Selection Matrix (Fig. 2-33). U3463 can produce the

symbols shown in row 2 of the Character Selection Matrix and U3465 produces the prefixes and some letters, used as prefixes, shown in row 4. U3467 and U3469 produce the remaining letters shown in rows 5 and 6 of the Character Selection Matrix.

All of the Character Generator stages receive the Column Digital Data from the Column Decoder U3418 in parallel. However, only one of the Character Generators receives row data at a particular time and only the stage receiving this row data is activated. For example, if column 2 is encoded, the five Character Generators are enabled so that either a 1, <, μ , V, or an N can be produced. If row 4 has been encoded at the same time, only the Prefix Character Generator U3465 will produce an output to result in a " μ " being displayed. The activated Character Generator provides current outputs for the Format Generator to produce the selected character on the CRT. In a similar manner, any of the characters shown in the Character Selection Matrix can be displayed by correct addressing of the row and column.

Decimal Point Logic and Character Position Counter

Decimal Point Logic and Character Position Counter U3470 performs two functions. The first function is to add a staircase current to the X (horizontal) signal to space the characters horizontally on the CRT. After each character is generated, the negative-going edge of the Ready signal at pin 5 advances the Character Position Counter. This produces a current step output at pin 3 which, when added to the X signal, causes the next character to be displayed one character space to the right. This stage can also be advanced when a Space instruction is encoded so a space is left between the displayed characters on the CRT. Row 10 information from the Row Decoder is connected to pin 4 of U3470. When row 10 and column 0 are encoded, the output of this stage advances one step to move the next character another space to the right. However, under this condition, no display is produced on the CRT during this time-slot, since the Character Generators are not activated.

Time-slot pulses 1, 2, and 3 are also connected to pin 4 of U3470 through VR3470, VR3471, and VR3472 respectively and R3470-R3473. This configuration adds a space to the displayed word during time-slots 1, 2, and 3 even if information is not encoded for display during these time-slots. With this feature, the information displayed during time-slot 4 (scaling data) always starts in the fourth character position whether data has been displayed in the previous time-slots or not. Therefore, the resultant CRT display does not shift position as normal-invert or cal-uncal information is encoded. The Word Trigger pulse connected to pin 8 resets the Character Position Counter to the first character position at the end of each word.

Input Pin of U3401 Activated	Command	Time-Slots
14	IDENTIFY	
12	Add one zero	
13	Add two zeros	
10	Decrease prefix	
11	Decrease prefix and add one zero	

Fig. 2-43. Typical output waveforms for Zeros Logic and Memory stage operation (at pin 7 of U3401).

The Decimal Point Logic portion of this stage allows decimal points to be added to the CRT display. With the Standard Readout Format, row 7, encoded coincident with columns 3 through 7, addresses a decimal at one of the five locations identified in row 7 of the Character Selection Matrix (Fig. 2-33). This instruction refers to the decimal point location in relation to the total number of characters possible in one word (see Fig. 2-44). For example, column 3 encoded with row 7 during time-slot 1 places a decimal point in location No. 3. As shown in Fig. 2-44, this displays a decimal point after the third character that can be displayed on the CRT. (The first three time-slots produce a space whether data is encoded or not; see previous paragraph.) The simultaneous application of row-7 data to the Y-input of the Format Generator through R3477 raises the decimal point so it appears between the displayed characters.

When decimal-point data is encoded, the CRT is unblanked so a readout display is presented. However, since row 7 or row 8 does not activate any of the five Character Generators, the CRT beam is deflected vertically a fixed amount to display the decimal point between the characters along the bottom line of the readout word. After the

be encoded for special formats. This decimal point can be placed in any character position by encoding column 9 with row 8 during the corresponding time slot. The application of row 8 data to the X and Y input of the Format Generator through R3478 and R3479 respectively, provides horizontal and vertical positioning current for the decimal points.

Format Generator

The X- and Y- deflection signals produced by the Character Generator stage are connected to pins 2 and 7, respectively, of Format Generator U3480. The Channel Address Code from the Channel Counter is also connected to pins 1, 8, and 15 of this stage. The Channel Address Code directs the Format Generator to add current to the X and Y signals to deflect the CRT beam to the area of the CRT associated with the plug-in channel that originated the information (see Fig. 2-32). The Channel Address Code and the resultant word positions are shown in Table 2-3. In addition, the character position current from the Decimal Point Logic and Character Position stage is added to the X (horizontal) input signal to space the characters horizontally on the CRT (see previous discussion). The Ready signal at pin 13 (coincident with the V-H Inhibit output) activates this stage when a character is to be displayed on the CRT.

Y-Output Amplifier

The Y-output signal at pin 6 of Format Generator U3480 is connected to the Y-Output Amplifier Q3486-Q3493. This stage provides a low impedance load for the Format Generator while providing isolation between the Readout System and the driven circuit(s). Vertical Separation adjustment R3490 changes the gain of this stage to control the vertical separation between the readout words displayed at the top and bottom of the graticule area.

X-Output Amplifier

The X-Output Amplifier Q3489-Q3499 operates like the Y-Output Amplifier, to provide the horizontal deflection from the readout signal available at pin 4 of U3480. The gain of this stage is fixed by the values of the resistors in the circuit.

Display Sequence

Figure 2-45 shows a flow chart for the Readout System. This chart illustrates the sequence of events that occurs in the Readout System each time a character is generated and displayed on the CRT.

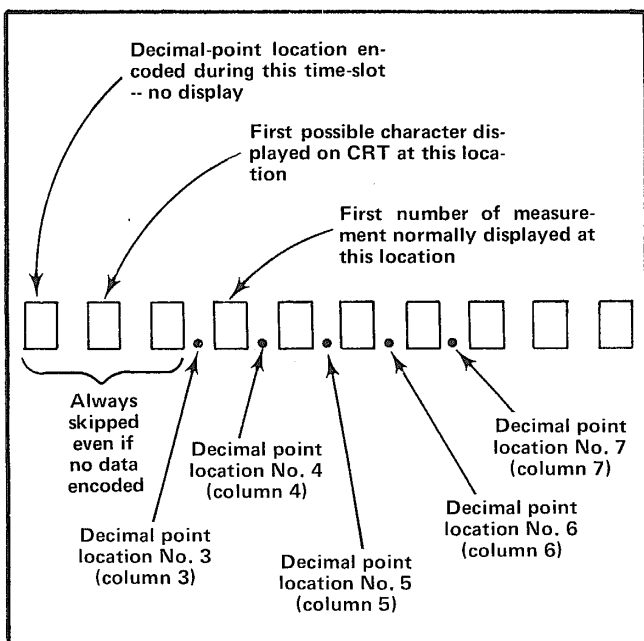

Fig. 2-44. Readout word relating 10 possible character locations to the decimal point instructions that can be encoded, and the resultant CRT display.

decimal point is produced in the addressed location, the CRT beam returns to the location indicated by the Character Position Counter to produce the remainder of the display.

Decimal-Point Character

In instruments serial number B050000 and higher, the addition of R3474-R3478-R3479 allows a decimal point to

MAIN INTERCONNECT 11

The Main Interconnect diagram shows the signal and power interconnections between the Acquisition and Display Units.

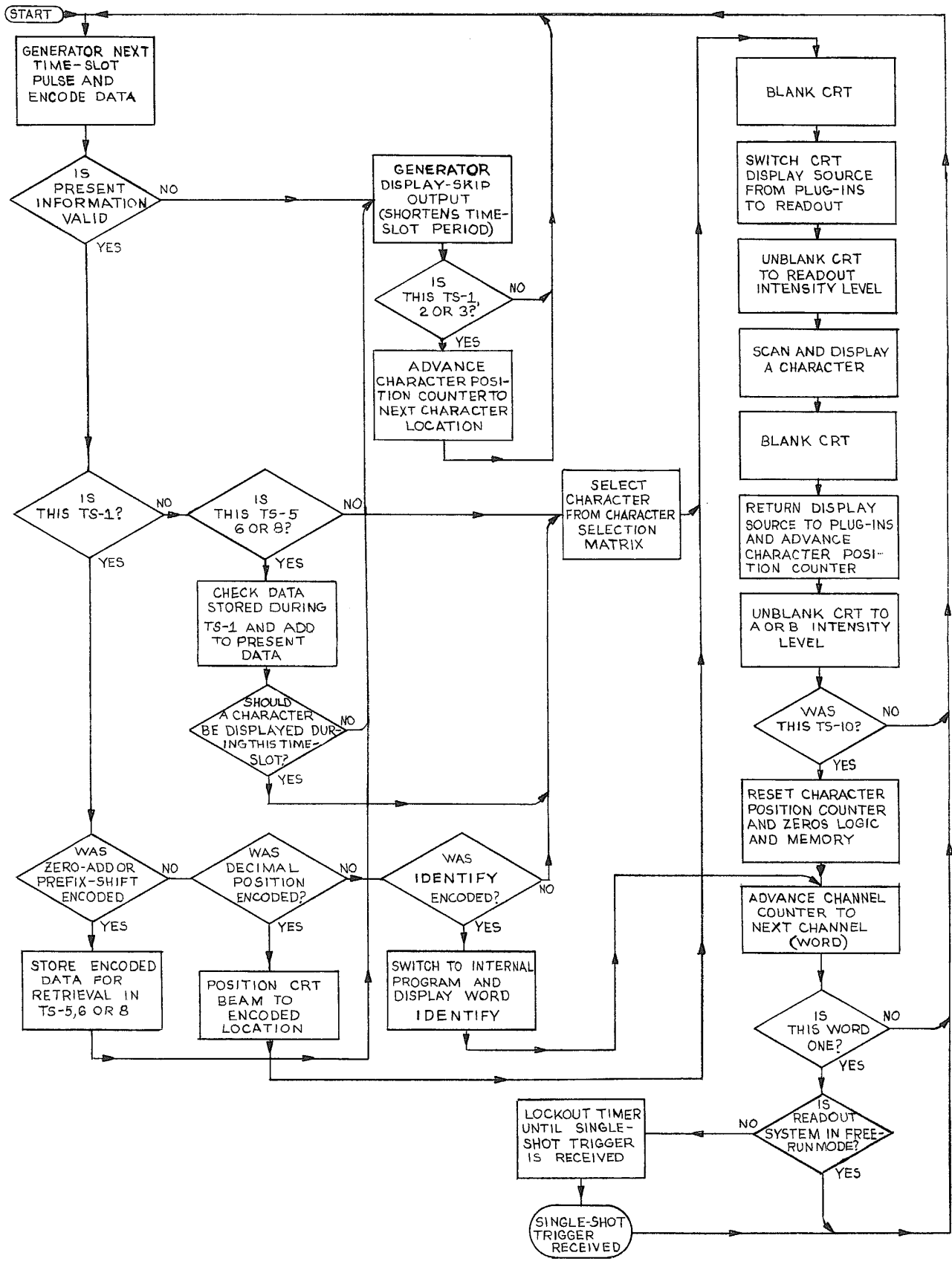

Fig. 2-45. Flow chart for character generation by the Readout System.

VERTICAL AMPLIFIER 12

The Vertical Amplifier circuit provides final amplification for the vertical signal before it is applied to the vertical deflection plates of the CRT. This circuit includes the delay line and an input to produce the vertical portion of a readout display. The BEAM FINDER switch limits the dynamic range of this circuit to compress an over-scanned display within the CRT viewing area. Figure 2-46 shows a detailed block diagram of the Vertical Amplifier circuit.

Delay Line

Delay Line DL5050 provides approximately 90 nanoseconds of delay for the vertical signal to allow the horizontal circuits time to initiate a sweep before the vertical signal reaches the vertical deflection plates of the CRT. This allows the instrument to display the leading edge of the signal when using internal triggering. The delay line is a coaxial type that does not produce preshoot or phase distortion in the CRT display.

Input Balance

The Input Balance stage provides vertical trace centering and an input from the Readout System to the Vertical Amplifier circuit. Q4479-Q4485 are connected as a paraphase amplifier. Centering adjustment R4493 determines the voltage level at the base of Q4485 to set the quiescent DC levels at pins 2 and 4 of U4413. R4493 is adjusted to vertically center the trace when the inputs to this circuit are at the same potential. The Y-Readout signal from the

Readout System is connected to the base of Q4479 through common-base connected Q4470. The paraphase amplifier converts the single-ended Y-Readout signal to a push-pull signal to drive the Output Amplifier.

Output Amplifier

The Output Amplifier stage is made up of integrated circuit U4413. The circuitry shown within the shaded area on diagram 12 is a representation of the internal circuitry of U4413. Notice that U4413 is made up of three similar push-pull stages. Each stage consists of a common-emitter transistor pair driving a pair of low input impedance, common-base transistors. R4439 sets the gain of the first stage. Thermistor RT4438 provides thermal compensation for the Vertical Amplifier circuit. RC network R4423-C4423-R4424-C4424-R4427-C4427 provides frequency compensation for the first stage. Gain adjustment R4406 sets the gain of the second stage to determine the overall gain of the Vertical Amplifier. C4401-L4401-R4404-L4410-L4411 provide fast-rise frequency compensation for the second amplifier stage. Bias adjustment R4415 sets the voltage level at pin 10 of U4413 to adjust the third amplifier stage for maximum voltage gain. RC networks R4455-C4455-R4453-C4453-R4451-C4451 and R4465-C4465-R4463-C4463-R4461-C4461 provide frequency compensation for the third stage.

BEAM FINDER switch S5007A disconnects the ground return for the third stage in U4413 to provide the beam finder function. This limits the dynamic range of this stage by limiting its current, so the display is compressed vertically within the graticule area.

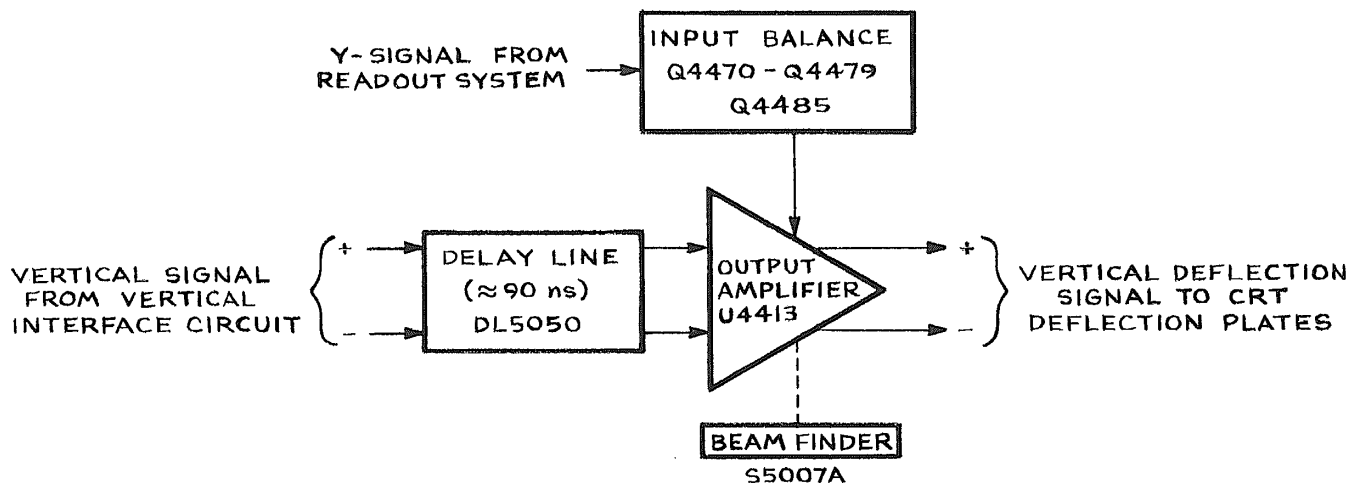

Fig. 2-46. Vertical Amplifier circuit detailed block diagram.

HORIZONTAL AMPLIFIER



The Horizontal Amplifier circuit amplifies the push-pull horizontal deflection signal from the Horizontal Interface circuit and connects it to the horizontal deflection plates of the CRT. This circuit also receives the X Readout signal from the Readout System to produce the horizontal portion of the readout display. Figure 2-47 shows a detailed block diagram of the Horizontal Amplifier circuit.

Input Amplifier

The horizontal signal from the Horizontal Interface circuit is connected to the bases of Q4321 and Q4331. The gain of this stage is controlled by the resistive network between the emitters of Q4321-Q4331. Horizontal Gain adjustment R4310 is variable to set the overall gain, and thermistor RT4313 provides thermal gain compensation. As the temperature goes up, the resistance of RT4313 goes down, resulting in less emitter degeneration. Therefore, the overall gain increases to compensate for the opposite temperature characteristic of the transistors in the Horizontal Amplifier circuit.

Transistor Q4304 normally supplies most of the emitter current of Q4321-Q4331. However, when the BEAM FINDER switch is actuated, Q4304 is no longer forward biased so the current through R4307-R4309 is determined by R4304 only. This results in less current to Q4321 and Q4331, so their dynamic range is limited. This reduces the effective gain of the horizontal system to keep the display

within the horizontal limits of the graticule, regardless of the setting of the horizontal positioning controls or the horizontal signal amplitude.

Horizontal Centering adjustment R4325 provides adjustment for differential unbalance in the Horizontal Amplifier circuit. The limiting network CR4323-CR4333-CR4340-CR4342 limits the input to the succeeding stages, so they always operate within their dynamic range and are not overdriven by excessive current from the Input Amplifier stage. Since the output from the Input Amplifier stage is a current signal, very little voltage change occurs across the limiting network. When horizontal deflection signals that produce an on-screen display are applied, CR4323 and CR4333 remain forward biased and CR4340-CR4342 are reverse biased. However, if high-amplitude signals are applied to this circuit as a result of sweep magnification or external signals, either CR4323 or CR4333 is reverse biased, depending on the polarity of the overdrive signal. This results in a sufficient voltage change at the anode of either CR4340 or CR4342 to forward bias it. The shunt diodes provide a current path for the signal current to limit the current change at the bases of Q4325-Q4335 during the overdrive condition.

For readout displays, the X Readout signal from the Readout System is connected to the base of Q4321 through R4300-R4322. The signal from the horizontal plug-in units is blocked in the Horizontal Interface circuit so the Readout System provides the only horizontal deflection. Q4321 and Q4331 operate as a paraphase amplifier to convert the single-ended readout signal at the base of Q4321 to a push-pull signal at the collectors of both Q4321 and Q4331.

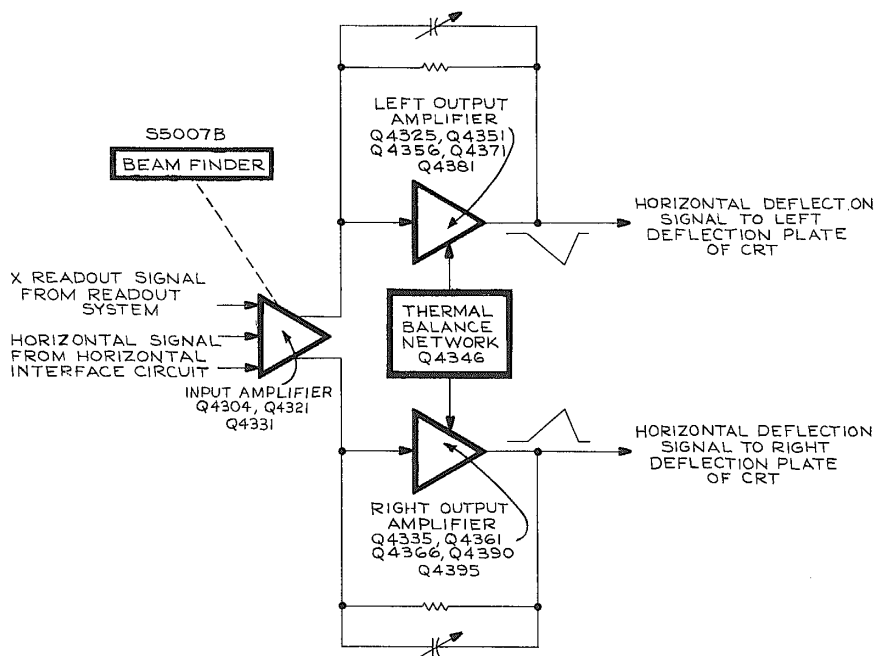

Fig. 2-47. Horizontal Amplifier circuit detailed block diagram.

CRT CIRCUIT 14

Left Output Amplifier

Transistors Q4325, Q4351, Q4356, Q4371, and Q4381 are connected as a current-driven feedback amplifier. The input current is converted to a voltage output signal to drive the left horizontal deflection plate of the CRT. Input transistor Q4325, an NPN transistor, responds best to positive-going input signals. The signal at the collector of Q4325 is connected to the emitters of output transistors Q4356-Q4371 through two parallel paths. High-frequency signals are connected through capacitor C4325. Low-frequency signals are connected to the output transistors through R4324-Q4351-R4354. The output transistors Q4356 and Q4371 are connected in the complementary configuration to provide less resistive loading at the output. The output signal at the collector of Q4356-Q4371 is connected to the left deflection plate of the CRT through R4375.

Negative feedback is provided from the collectors of Q4356-Q4371 to the base of Q4325 through feedback network R4374-C4374-Q4381-R4329-C4329. Emitter follower Q4381 in the feedback network provides current gain for the feedback signal. With this configuration, the input impedance of the Left Output Amplifier is low since the feedback network beyond the emitter followers is effectively reduced in impedance as far as the input signal is concerned. Variable capacitor C4374 adjusts the transient response of the feedback network to provide good linearity at fast sweep rates. C4385-R4385 provide adjustment for correct high-frequency gain versus frequency response in the amplifier.

Right Output Amplifier

Basic operation of the Right Output Amplifier stage is the same as just described for the Left Output Amplifier stage. Notice that the input transistor in this stage is complementary to the corresponding transistor in the Left Output Amplifier stage. Therefore, this stage provides the best response to negative-going input signals. C4391 provides linearity adjustment for the Right Output Amplifier at fast sweep rates. The output signal at the collectors of Q4366-Q4395 is connected to the right deflection plate of the CRT through R4393.

Thermal Balance Network

Q4346 provides thermal balance for the Horizontal Amplifier circuit. The Thermal Balance adjustment R4346 sets the bias on Q4346 and thereby determines the operating voltage for Q4325-Q4335. This adjustment compensates for DC shift in the CRT display to reduce low-frequency signal cross talk. Diode CR4348 provides reverse-voltage breakdown protection for Q4346 when the instrument is first turned on. Diodes CR4346 and CR4344 establish the operating bias for Q4325-Q4335.

The CRT Circuit provides the control circuits and the high-voltage potentials necessary for the operation of the cathode-ray tube (CRT). This circuit includes the Z-Axis Amplifier stage to set the intensity of the CRT display and the Auto-Focus Amplifier stage to maintain optimum focus of the CRT display. The CRT Circuit also contains the Graticule-Light Supply. Figure 2-48 shows a detailed block diagram of the CRT Circuit.

High-Voltage Transformer

The High-Voltage Transformer, T4201, is driven by the 20-kilohertz square-wave voltage from the Inverter/Rectifiers circuit (secondary of Low-Voltage Transformer T3101 on diagram 8). Four secondary windings on T4201 provide power for the Graticule-Light Supply, +150-Volt Supply, CRT heater voltage, Anode Voltage Multiplier, and the CRT-Cathode Supply. The square-wave output of T4201 also drives the Control-Grid DC Restorer and Focus-Grid DC Restorer stages through R4217 and R4214 respectively.

+150-Volt Supply

The +150-Volt Supply provides a semi-regulated voltage for use in several circuits in the 7704A (semi-regulation is achieved by Inverter Regulator; see Inverter/Rectifiers description for further information). Bridge rectifier CR4201-CR4202-CR4203-CR4204 rectifies the voltage from the secondary of T4201. R4201-C4201 filter the rectified voltage.

Graticule-Light Supply

The graticule lights DS5001-DS5002-DS5003 are powered by the Graticule-Light Supply Q4250-Q4254. Rectified voltage for this supply is provided by CR4250 from a secondary winding of T4201. The setting of the front-panel GRAT ILLUM control R5000 determines the bias on the base of Q4254. The level on the collector of Q4254 then determines the current through Q4250 and the graticule lights.

Cathode-Supply Regulator

A sample of the output of the CRT-Cathode Supply is connected to the Cathode-Supply Regulator stage through divider R4123-R4240-R4241. Fast changes of the cathode-supply output are coupled to the Cathode-Supply Regulator through R4244-C4244. U4110 is connected as an error amplifier to sense any change in the voltage level at its non-inverting input (pin 3). The +50-Volt Supply, connected to R4123, and the ground connected to pin 2-U4110 through R4120 provide the reference for this stage. High Voltage adjustment R4123 sets the quiescent level at pin 3-U4110 for a -2.96-kilovolt operating potential at the

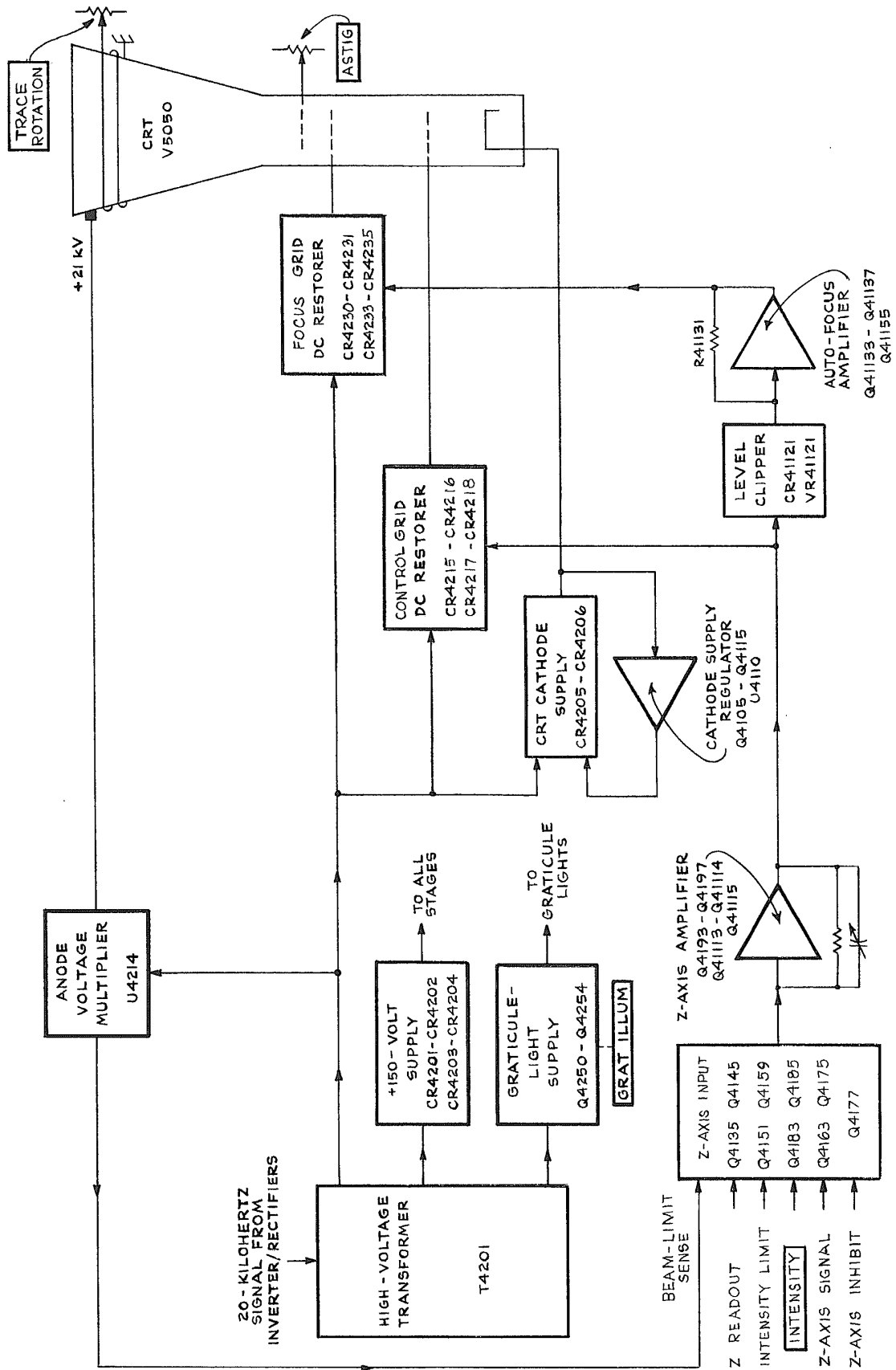

Fig. 2-48. Detailed block diagram of CRT Circuit.

CRT cathode. Q4105 and Q4115 are connected as a collector-coupled complementary amplifier driven by U4110 to correct the CRT-Cathode Supply for high- and low-frequency changes respectively.

Regulation occurs as follows: If the CRT cathode voltage becomes less negative, a positive-going change is coupled to the input of U4110 at pin 3 and results in a positive-going output at pin 6. This positive-going change is inverted by Q4105-Q4115 to a negative-going change at their collectors. This causes the voltage across C4205 to increase during the positive half cycle of the input waveform. During the negative half cycle, the increased voltage across C4205 increases the voltage at the output of the CRT-Cathode Supply to correct the original error. High-frequency correction signals are AC coupled to the CRT cathode through C4208.

Control-Grid DC Restorer

The Control-Grid DC Restorer stage elevates the DC level of the Z-Axis Amplifier output to a potential more negative than the CRT cathode. This action allows the control grid to control the CRT beam current. The Control-Grid DC Restorer stage is driven by the square-wave output of T4201. CR4217 and CR4218 are forward biased during the positive and negative half cycles of the input square wave respectively to limit the square-wave amplitude at their junction. Grid Bias adjustment R4135 sets the voltage on the cathode of CR4217 to establish the forward-bias level and peak positive level at the anode of CR4217. The DC level of the Z-Axis Amplifier output determines the voltage on the anode of CR4218 to establish the forward-bias level and peak negative level at the cathode of CR4218. The limited-amplitude square wave at the junction of CR4217-CR4218 is coupled to the junction of CR4215-CR4216 through C4215. During the positive half cycle of the input square wave, CR4215 is forward biased to clamp its anode at the CRT-cathode voltage level. During the negative half cycle, C4216 is charged through CR4216 to a voltage level more negative than the CRT cathode by an amount equal to the difference between the Grid Bias adjustment setting and the Z-Axis Amplifier output level. High-frequency Z-Axis Amplifier signals are coupled to the control grid through C4219 and R4220-C4216.

Focus-Grid DC Restorer

The operation of the Focus-Grid DC Restorer is similar to the operation of the Control-Grid DC Restorer. The limited-amplitude square wave at the junction of CR4230-CR4231 is coupled to the junction of CR4233-CR4235 through C4230. The amplitude of the positive half cycle of the input square wave is clamped at approximately +150 volts by CR4230. The peak negative amplitude is established by the DC level of the Auto-Focus Amplifier output through CR4231. During the positive half cycle, the focus-grid voltage is clamped to the voltage set by the FOCUS control R5001 through

R4235-CR4235-CR4233. During the negative half cycle, C4231 charges through CR4233 to establish the proper level at the focus-grid electrode.

Z-Axis Input

The Z-Axis Input stage combines the various signals that affect the display intensity into one signal to provide the drive to the input of the Z-Axis Amplifier stage at the base of Q4197. For normal operation, the Z-Axis signal from the Logic Circuit determines the output of this stage. Other signals affecting the output include the front-panel (Display Unit) INTENSITY control R5004, the Intensity Limit input from the plug-in compartments, and the HV Sense signal from the Anode Voltage Multiplier. During readout displays, the Z-Axis Inhibit signal from the Readout System turns off Q4177 so the output of this stage is determined by the Z Readout input only.

Z-Axis Amplifier

The Z-Axis Amplifier stage is a current driven, shunt-feedback amplifier with voltage output. The output voltage provides the drive signal to control the CRT intensity level through the Control-Grid DC Restorer stage. The output of the Z-Axis Amplifier is also connected to the Auto-Focus Amplifier stage to control the operation of the Auto-Focus Amplifier stage.

The base of Q4197 is the summing point (input) of the Z-Axis Amplifier stage. R41109-C41109 provide feedback from the output of this stage to the summing point. C41109 is adjustable to provide optimum step response with minimum overshoot or ringing. Otherwise, the CRT-display intensity would vary following sudden changes in intensity level. Z-Axis Peaking adjustment R4197 provides additional transient-response adjustment. The signal at the collector of Q4193 is DC-coupled to the base of Q41115 through R41101 to maintain good low-frequency response and to provide a fast falling edge on the output signal. The fast-changing portions of the input signal are coupled to the base of Q41113 through C41107.

Q41113-Q41114 are connected as a collector-coupled complementary amplifier. Q41113 is a PNP-type transistor, so it responds faster to negative-going changes at its base than to positive-going changes. This action provides a fast-rising edge on the output signal (fast-falling edge is provided by Q41115, an NPN-type transistor).

Auto-Focus Amplifier

The Auto-Focus Amplifier stage develops control voltages to maintain optimum focus of the CRT display. When the FOCUS control is set for best definition of the CRT display at low to medium settings of the intensity

Circuit Description—7704A Service

controls, this stage will maintain optimum focus for all portions of the display as it switches between readout, normal or intensified displays, slow or fast sweeps, and high- or low-intensity displays.

The Focus-Grid voltage required to maintain a focused display is fairly constant for low- and medium-intensity displays. However, for displays which require intensity control settings beyond midrange, the voltage requirement at the Focus Grid increases linearly with the increase in intensity drive at the output of the Z-Axis Amplifier stage. CR41121 and zener diode VR41121 clip the output level of the Z-Axis Amplifier stage, so the Auto-Focus Amplifier is not activated for low- or medium-intensity displays. Quiescently, the anode of VR41121 rests near zero volts. The positive voltage applied through R41121 sets the cathode of VR41121 at about +30 volts. Therefore, CR41121 is held reverse biased until its anode rises above about +30.5 volts. Then the portion of the Z-Axis drive signal that exceeds the 30-volt clipping level is coupled to the Auto-Focus Amplifier stage.

Q41133-Q41137-Q41155 are connected as an inverting operational amplifier to amplify the output of the Level Clipper and drive the Focus-Grid electrode. Auto-Focus Gain adjustment R41127 determines the amount of signal connected to the base of Q41133 to set the overall gain of

the Auto-Focus Amplifier. R41131 provides feedback from the output of this stage to the input. The capacitor shown next to R41131 (diagram 14) represents the gimmick-wire capacitor wrapped around the resistor body. This gimmick-wire capacitor is positioned to adjust the amount of AC feedback giving the best overall focus of displays with fast-changing intensity levels.

CRT Control Circuit

The ASTIG adjustment R5002, used in conjunction with the FOCUS control to obtain a well-defined display, varies the level on the astigmatism grid. Geometry adjustment R41171 varies the positive level on the horizontal deflection plate shield to control the overall geometry of the display.

Two adjustments control the trace alignment by varying the magnetic field around the CRT. Y-Axis Align adjustment R41173 controls the current through L5007, which affects the CRT beam after vertical deflection but before horizontal deflection. Therefore, it affects only the vertical (Y) components of the display. TRACE ROTATION adjustment R5003 controls the current through L5003 and affects both the vertical and horizontal rotation of the beam.

MAINTENANCE

This section of the manual contains maintenance information for use in preventive maintenance, corrective maintenance, or troubleshooting of the 7704A.

Panel Removal

WARNING

Dangerous potentials exist at several points throughout this instrument. When the instrument is operated with the covers removed, do not touch exposed connections or components. Some transistors have voltages present on their cases. Disconnect power before cleaning the instrument or replacing parts.

The side and bottom panels of the 7704A are held in place by slotted fasteners. To remove the panels, turn each fastener counterclockwise a quarter turn with a large screwdriver, coin, or similar device. Then, lift the panel away from the instrument. The panels protect this instrument from dust in the interior, and also provide protection to personnel from the operating potentials present. In addition, they reduce the EMI radiation from the instrument and EMI interference to the display due to other equipment.

Power-Unit Removal

WARNING

Extreme caution must be used when troubleshooting in the power supply due to the line voltage, high voltage and high current potentials present. Refer to the discussion entitled Access to Components in Power Unit for information on how to remove the protective cover from the power unit.

The power unit can be slid out of the rear of the 7704A to gain access to the Logic circuit board and for power-unit service. To remove the power unit, first disconnect the instrument from the power source. Remove the four screws which hold the power unit to the rear frame (see Fig. 3-1). Slide the power unit out of the rear of the instrument until it can be set on the work surface (guide the cables so they do not catch on other parts of the instrument). The power

unit remains connected to the rest of the instrument so it can be operated in this position for troubleshooting or calibration. Reverse this procedure when replacing the power unit; use care not to pinch the cables as the power unit is replaced. Be sure that all the securing screws are tight to hold the power unit in place properly.

PREVENTIVE MAINTENANCE

Preventive maintenance consists of cleaning, visual inspection, lubrication, etc. Preventive maintenance performed on a regular basis may prevent instrument breakdown and will improve the reliability of this instrument. The severity of the environment to which the 7704A is subjected determines the frequency of maintenance. A convenient time to perform preventive maintenance is preceding recalibration of the instrument.

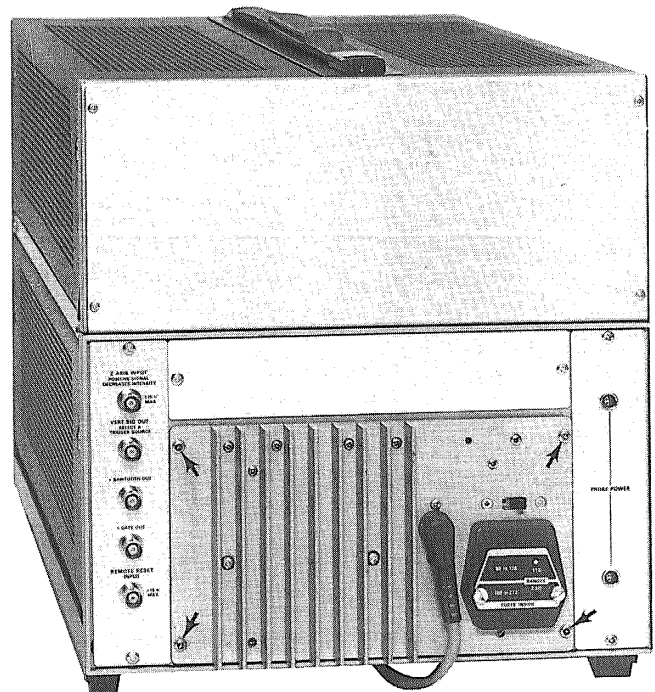

Fig. 3-1. Power-unit securing screws.

Cleaning

General. The 7704A should be cleaned as often as operating conditions require. Accumulation of dirt in the instrument can cause overheating and component breakdown. Dirt on components acts as an insulating blanket and prevents efficient heat dissipation. It also provides an electrical conduction path which may result in instrument failure. The side panels provide protection against dust in the interior of the instrument. Operation without the panels in place necessitates more frequent cleaning.

CAUTION

Avoid the use of chemical cleaning agents which might damage the plastics used in this instrument. In particular, avoid chemicals which contain benzene, toluene, xylene, acetone, or similar solvents.

Exterior. Loose dust accumulated on the outside of the 7704A can be removed with a soft cloth or small brush. The brush is particularly useful for dislodging dirt on and around the front-panel controls. Dirt which remains can be removed with a soft cloth dampened in a mild detergent and water solution. Abrasive cleaners should not be used.

CRT. Clean the plastic light filter, faceplate protector, and the CRT face with a soft, lint-free cloth dampened with denatured alcohol.

The CRT mesh filter (furnished with Option 3 only) can be cleaned in the following manner:

1. Hold the mesh filter in a vertical position and brush lightly with a soft No. 7 water-color brush to remove light coatings of dust or lint.

2. Greasy residues or dried-on dirt can be removed with a solution of warm water and a neutral-pH liquid detergent. Use the brush to lightly scrub the filter.

3. Rinse the filter thoroughly in clean water and allow to air dry.

4. If any lint or dirt remains, use clean low-pressure air to remove it. Do not use tweezers or other hard cleaning tools on the filter, as the special finish may be damaged.

5. When not in use, store the mesh filter in a lint-free, dust-proof container such as a plastic bag.

Interior. Dust in the interior of the instrument should be removed occasionally due to its electrical conductivity under high-humidity conditions. The best way to clean the interior is to blow off the accumulated dust with dry, low-pressure air. Remove any dirt which remains with a soft brush or a cloth dampened with a mild detergent and water solution. A cotton-tipped applicator is useful for cleaning in narrow spaces or for cleaning ceramic terminal strips and circuit boards.

The high-voltage circuits, particularly parts located in the high-voltage compartment and the area surrounding the post-deflection anode leads, should receive special attention. Excessive dirt in these areas may cause high-voltage arcing and result in improper instrument operation.

Lubrication

General. The reliability of potentiometers, switches, and other moving parts can be maintained if they are kept properly lubricated. However, over-lubrication is as detrimental as too little lubrication. A lubrication kit containing the necessary lubricants and instructions is available from Tektronix, Inc. Order Tektronix Part No. 003-0342-01.

Visual Inspection

The 7704A should be inspected occasionally for such defects as broken connections, broken or damaged ceramic strips, improperly seated semiconductors, damaged or improperly installed circuit boards, and heat-damaged parts.

The corrective procedure for most visible defects is obvious; however, particular care must be taken if heat-damaged components are found. Overheating usually indicates other trouble in the instrument; therefore, it is important that the cause of overheating be corrected to prevent recurrence of the damage.

Semiconductor Checks

Periodic checks of the semiconductors in the 7704A are not recommended. The best check of semiconductor performance is actual operation in the instrument. More details on checking semiconductor operation are given under troubleshooting.

Recalibration

To assure accurate measurements, check the calibration of this instrument after each 1000 hours of operation or every six months if used infrequently. In addition, replacement of components may necessitate recalibration of the affected circuits. The calibration procedure can also be

helpful in localizing certain troubles in the instrument. In some cases, minor troubles may be revealed and/or corrected by recalibration.

TROUBLESHOOTING

The following information is provided to facilitate troubleshooting of the 7704A. Information contained in other sections of this manual should be used along with the following information to aid in locating the defective component. An understanding of the circuit operation is very helpful in locating troubles, particularly where integrated circuits are used.

Troubleshooting Equipment

The following equipment is useful for troubleshooting the 7704A.

1. Transistor Tester

Description: Dynamic-type tester. Must be capable of measuring reverse breakdown voltages of at least 400 volts.

Purpose: To test the semiconductors used in this instrument.

Recommended type: Tektronix Type 576 Curve Tracer.

2. Multimeter

Description: VTVM, 10 megohm input impedance and 0 to 500 volts range, AC and DC; ohmmeter, 0 to 50 megohms. Accuracy, within 3%. Test probes must be insulated to prevent accidental shorting.

Purpose: To check voltages and for general troubleshooting in this instrument.

NOTE

A 20,000 ohms/volt VOM can be used to check the voltages in this instrument if allowances are made for the circuit loading of the VOM at high-impedance points.

3. Test Oscilloscope

Description: Frequency response, DC to 100 megahertz minimum; deflection factor, 5 millivolts to 5 volts/division and 1 milliampere to 1 ampere/division. A 10X, 10-megohm voltage probe should be used to reduce circuit loading for voltage measurements.

Purpose: To check operating waveforms in this instrument.

Recommended type: Tektronix 7603 Oscilloscope with 7A16A Amplifier, 7A14 Current Probe Amplifier, and

7B50 Time Base plug-in units. Use a P6053 10X probe and a P6021 Current Probe.

4. Isolation Transformer

Description: 1:1 turns ratio, 500 volt-amperes minimum rating, 50-60 cycle. Must have three-wire power cord, plug, and receptacle with ground connection carried through from input to output.

Purpose: To isolate the 7704A from the line potential when troubleshooting in the power supply.

Recommended type: Stancor No. P6298 (for 115-volt line only) modified to include three-wire power cord, plug, and receptacle.

5. Variable Autotransformer

Description: Output variable from 0 to 140 volts, 10 amperes minimum rating. Must have three-wire power cord, plug, and receptacle.

Purpose: To vary the input line voltage when troubleshooting in the power supply.

Recommended type: General Radio W10MT3W Variac Autotransformer.

Troubleshooting Techniques

This troubleshooting procedure is arranged in an order which checks the simple trouble possibilities before proceeding with extensive troubleshooting. The first few checks assure proper connection, operation, and calibration. If the trouble is not located by these checks, the remaining steps aid in locating the defective component. When the defective component is located, it should be replaced following the replacement procedures given under Corrective Maintenance.

1. Check Control Settings. Incorrect control settings can indicate a trouble that does not exist. If there is any question about the correct function or operation of any control, see the Operators Manual.

2. Check Associated Equipment. Before proceeding with troubleshooting of the 7704A, check that the equipment used with this instrument is operating correctly. Check that the signal is properly connected and that the interconnecting cables are not defective. Also, check the power source. The associated plug-in units can be checked for proper operation by substituting other units which are known to be operating properly (preferably of the same types). If the trouble persists after substitution, the 7704A is probably at fault.

3. Visual Check. Visually check the portion of the instrument in which the trouble is located. Many troubles can be located by visual indications such as unsoldered connections, broken wires, damaged circuit boards, damaged components, etc.

4. Check Instrument Calibration. Check the calibration of this instrument, or the affected circuit if the trouble appears in one circuit. The apparent trouble may only be a result of misadjustment or may be corrected by calibration. Complete calibration instructions are given in the Calibration section.

5. Isolate Trouble to a Circuit. To isolate trouble to a particular circuit, note the trouble symptom. The symptom often identifies the circuit in which the trouble is located. For example, poor focus indicates that the CRT circuit (includes Auto Focus circuits) is probably at fault. When trouble symptoms appear in more than one circuit, check affected circuits by taking voltage and waveform readings. Also check for the correct output signals at the rear-panel output connectors with a test oscilloscope. If the signal is correct, the circuit is working correctly up to that point. For example, correct sawtooth output indicates that the time-base unit and sawtooth out portion of the Output Signals circuit is operating correctly. If a malfunction in the Readout System is suspected of causing trouble to appear in the Z-Axis Amplifier, Vertical Amplifier, or Horizontal Amplifier circuits, the trouble can be localized by removing the Readout System circuit board. This board can be removed without affecting the operation of other circuits in the instrument.

Incorrect operation of all circuits often indicates trouble in the power supply. Check first for correct voltage of the individual supplies. However, a defective component elsewhere in the instrument can appear as a power-supply trouble and may also affect the operation of other circuits.

If incorrect operation of the power supplies is suspected, connect the 7704A to a variable autotransformer. Then, check each power supply for correct regulation with a DC voltmeter (0.1% accuracy), and correct ripple with a test oscilloscope, while varying the autotransformer throughout the regulating range of this instrument (see rear-panel Line Selector for regulating range). Table 3-1 lists the tolerances of the power supplies in the 7704A. These voltages are measured between the power-supply test points and chassis ground. (P32G connects to the L.V. Regulator board in the power unit; P43 connects to the rear of the Horizontal Amplifier board.) Power-supply test points are shown on page 6-31 in the Diagrams section. If a power-supply voltage is within the listed tolerance, the supply can be assumed to be working correctly. If outside the tolerance, the supply may be misadjusted or operating incorrectly. Use the procedure given in the Calibration section to adjust the power supplies.

TABLE 3-1

Power Supply Tolerance and Ripple
(referenced to chassis ground)

Power Supply	Test Point	Tolerance	Typical ripple (peak-to-peak)
-50 Volt	pin 6-P32G	±0.20 volt	2 millivolts
-15 Volt	pin 1-P32G	±0.15 volt	2 millivolts
+5 Volt	pin 2-P32G	±0.10 volt	2 millivolts
+15 Volt	pin 4-P32G	±0.15 volt	2 millivolts
+50 Volt	pin 5-P32G	±0.50 volt	5 millivolts
+155 Volt	pin 1-P43	±5.0 volts	500 millivolts

Figure 3-2 provides a guide for locating a defective circuit. Start at the top of the chart and perform the checks given on the left side of the page until a step is found that does not produce the indicated results. Further checks, or the circuit in which the trouble is probably located, are listed to the right of the step. This chart does not include checks for all possible defects; use steps 6 and 7 in such cases.

After the defective circuit has been located, proceed with steps 6 and 7 to locate the defective component(s).

6. Check Voltages and Waveforms. Often the defective component can be located by checking for the correct voltage or waveform in the circuit.

7. Check Individual Components. The following procedures describe methods of checking individual components in the 7704A. Components that are soldered in place are best checked by first disconnecting one end. This isolates the measurement from the effects of surrounding circuitry.

A. SEMICONDUCTORS.



Power switch must be turned off before removing or replacing semiconductors.

A good check of transistor operation is actual performance under operating conditions. A transistor can be most effectively checked by substituting a new component for it (or one which has been checked previously). However, be sure that circuit conditions are not such that a replacement transistor might also be damaged. If substitute transistors are not available, use a dynamic tester. Static-type testers are not recommended, since they do not check operation under simulated operating conditions.

IC's (integrated circuits) can be checked with a voltmeter, test oscilloscope, or by direct substitution. A good understanding of circuit operation is essential to troubleshooting circuits using IC's. Use care when checking voltages and waveforms around the IC's so that adjacent leads are not shorted together. A convenient means of clipping a test probe to the 14- and 16-pin IC's is with an IC test clip. This device also doubles as an extraction tool. The lead configuration for the semiconductors used in this instrument are shown on or adjacent to each diagram page.

B. DIODES.

A diode can be checked for an open or for a short circuit by measuring the resistance between terminals with an ohmmeter set to the R X 1k scale. The diode resistance should be very high in one direction and very low when the meter leads are reversed. Do not check tunnel diodes or back diodes with an ohmmeter.



Do not use an ohmmeter scale that has a high internal current. High currents may damage the diode.

The cathode end of each glass-encased diode is indicated by a stripe, a series of stripes, or a dot. For most silicon or germanium diodes with a series of stripes, the color-code identifies the three significant digits of the Tektronix Part Number using the resistor color-code system (e.g., a diode color-code pink-, or blue-, brown-gray-green indicates Tektronix Part Number 152-0185-00). The cathode and anode ends of metal-encased diodes can be identified by the diode symbol marked on the body.

C. RESISTORS.

Check the resistors with an ohmmeter. See the Electrical Parts List for the tolerance of the resistors used in this instrument. Resistors normally do not need to be replaced unless the measured value varies widely from the specified value.

D. INDUCTORS.

Check for open inductors by checking continuity with an ohmmeter. Shorted or partially shorted inductors can usually be found by checking the waveform response when high-frequency signals are passed through the circuit. Partial shorting often reduces high-frequency response (roll-off).

E. CAPACITORS.

A leaky or shorted capacitor can best be detected by checking resistance with an ohmmeter on the highest scale.

Do not exceed the voltage rating of the capacitor. The resistance reading should be high after initial charge of the capacitor. An open capacitor can best be detected with a capacitance meter or by checking if the capacitor passes AC signals.

8. Repair and Readjust the Circuit. If any defective parts are located, follow the replacement procedures given in this section. Be sure to check the performance of any circuit that has been repaired or had any electrical components replaced.

Special Adjustment Procedures

Several interface adjustments are provided in the Acquisition Unit to allow use with different Display Units. It is not usually necessary to perform these adjustments during recalibration of the complete system. However, if components are replaced in the interface circuits or if the Acquisition Unit is used in a different system, adjustment might be required. The need for adjustment is indicated if the vertical or horizontal adjustments in the Display Unit cannot be performed according to the Calibration procedure.

Equipment Required. The following equipment is required to calibrate the Acquisition Unit interface:

1. Test-oscilloscope system

Description: Differential inputs; frequency response, DC to 30 megahertz minimum; deflection factor, 50 millivolts/division.

Recommended type: Tektronix 7403N Oscilloscope with two 7A15A Amplifier units or one 7A18N Dual-Trace Amplifier and 7B50 Time-Base.

2. Signal Standardizer Calibration Fixture

Description: Produces gain-check and pulse-response waveforms.

Recommended type: Tektronix 067-0587-01 Calibration Fixture.

3. Adapter (two required)

Description: Adapts GR874 connector to Tektronix coaxial connector.

Recommended type: Tektronix Part No. 017-0093-00.

CIRCUIT ISOLATION TROUBLESHOOTING CHART

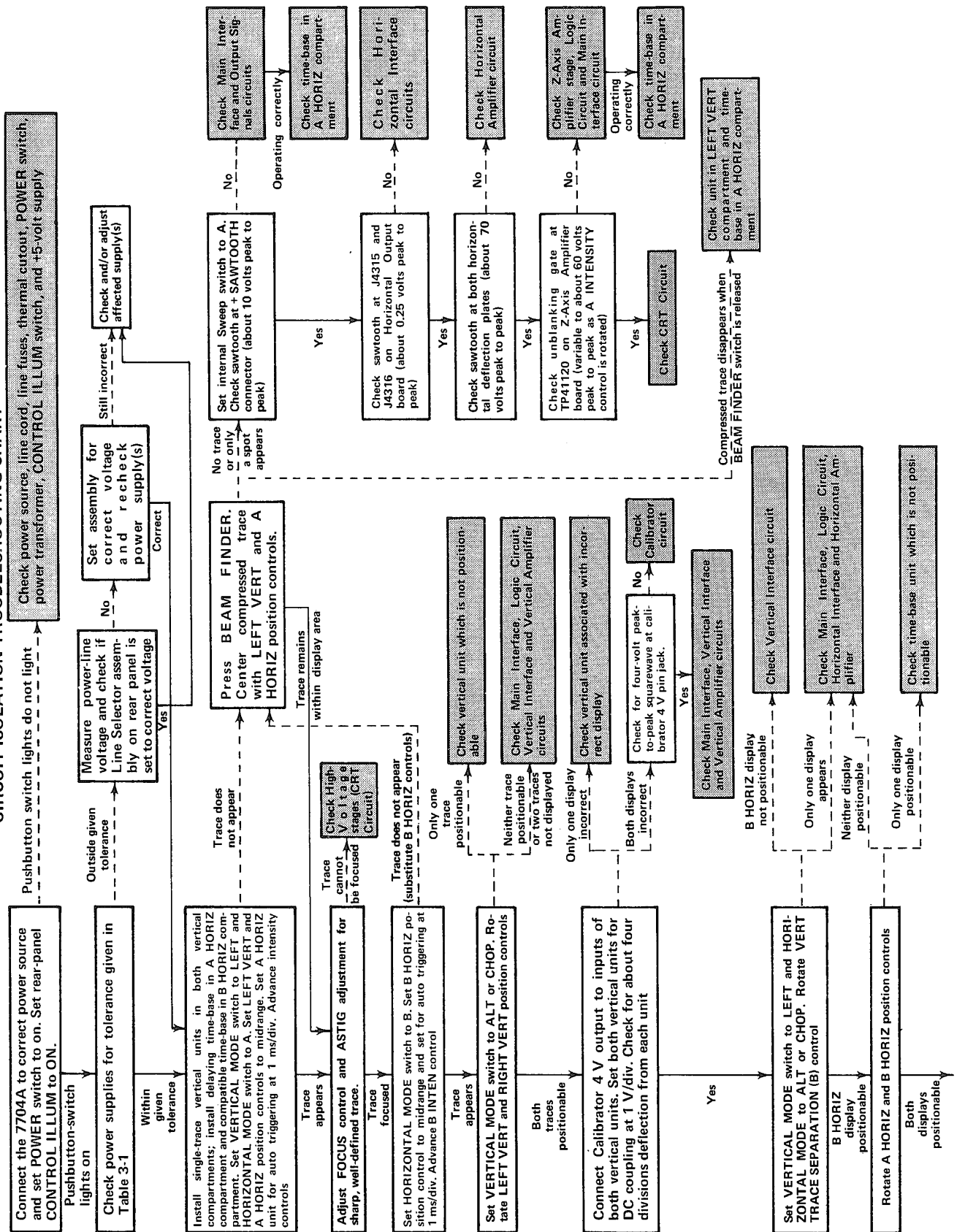

Fig. 3-2. Troubleshooting Chart for 7704A.

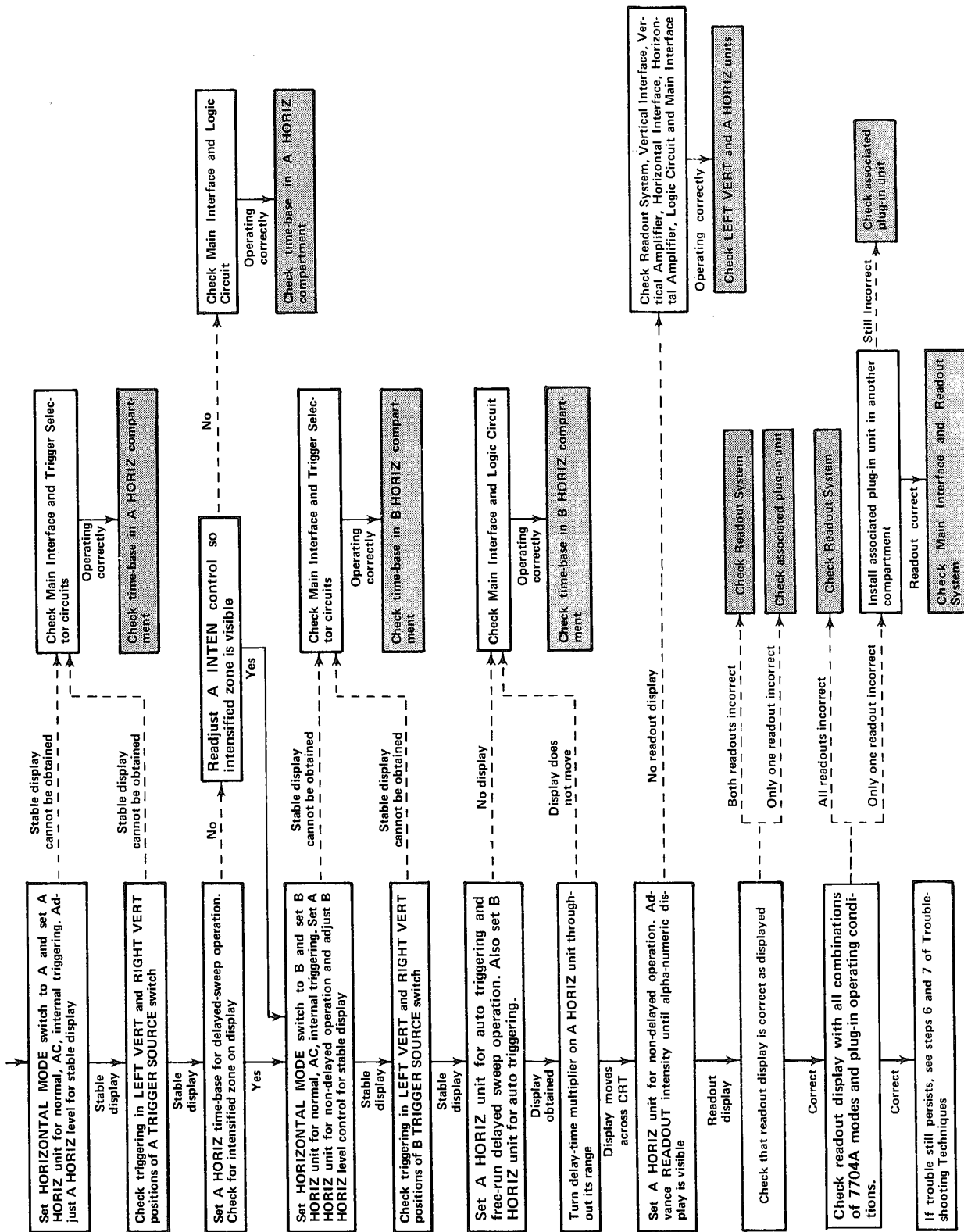

Fig. 3-2. (cont)

A

Control Settings. Set the 7704A controls as follows:

POWER	OFF
VERTICAL MODE	RIGHT
VERT TRACE SEPARATION (B)	Midrange
A TRIGGER SOURCE	VERT MODE
A INTEN	Midrange
HORIZONTAL MODE	A
B INTEN	Midrange
B TRIGGER SOURCE	VERT MODE
READOUT	OFF

Adjust Vertical Interface Centering and Gain. To calibrate the Vertical Interface, set the controls as given under Control Settings and proceed as follows:

a. Disconnect coaxial connectors P4417 and P4418 from A44, Vertical Amplifier board (see Fig. 3-3).

b. Connect P4417 and P4418 to the vertical channels of the test oscilloscope with the adapters and cables. (If the test oscilloscope has a high input impedance, use 50-ohm terminations at the vertical-channel inputs.)

c. Set the POWER switch to on.

d. Set the test oscilloscope for differential operation between the vertical channels (added display mode with one channel inverted; invert the channel to which P4418 is connected), and a sweep rate of 100 microseconds/division.

e. Set the test-oscilloscope vertical channels for a deflection factor of 50 millivolts/division with the inputs grounded.

f. Establish a zero-volt reference level for the test-oscilloscope display by positioning the trace to the center horizontal line of the graticule. Do not change the test-oscilloscope position controls after setting this level.

g. Set the vertical channels of the test oscilloscope for DC input coupling.

h. ADJUST—Interface Centering adjustment R2222 (see Fig. 3-4) for a display DC level within 0.2 division (10 millivolts) of the zero-volt reference level in the LEFT and RIGHT positions of the VERTICAL MODE switch.

i. Install the signal standardizer calibration fixture in the RIGHT VERT compartment.

j. Set the VERTICAL MODE switch to RIGHT.

k. Set the calibration fixture Test switch to Vert or Horiz Gain and the Rep Rate switch to 10 kHz.

l. ADJUST—Interface Gain adjustment R2247 (see Fig. 3-4) for a test-oscilloscope display of nine traces with six divisions ± 0.9 division deflection between the second and eighth traces (300 millivolts within 45 millivolts).

m. Set the POWER switch to off.

n. Disconnect P4417 and P4418 from the test oscilloscope and connect them to their respective jacks on the Vertical Amplifier board.

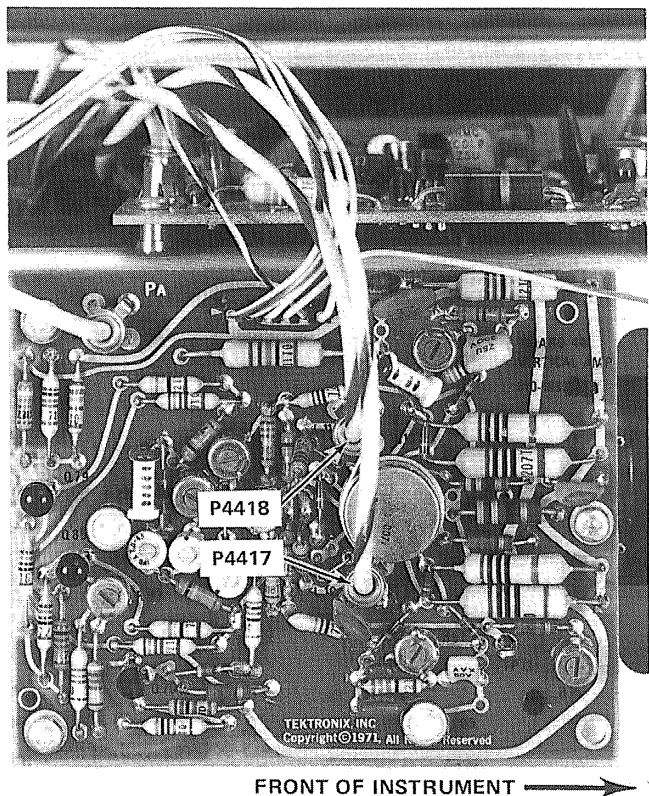

Fig. 3-3. Location of P4417 and P4418 on A44-Vertical Amplifier board.

Adjust Horizontal Interface Gain. To calibrate the Horizontal Interface, set the controls as given under Control Settings and proceed as follows:

a. Disconnect coaxial connectors P4315 and P4316 from the Horizontal Output board (see Fig. 3-5).

b. Connect P4315 and P4316 to the vertical channels of the test oscilloscope with the adapters and cables. (If the test oscilloscope has a high-impedance input, use 50-ohm terminations at the vertical-channel inputs.)

c. Set the POWER switch to on.

d. Set the test oscilloscope for differential operation between the vertical channels (added display mode with one channel inverted; invert the channel to which P4316 is connected), and a sweep rate of 100 microseconds/division. Free run the sweep.

e. Set the test-oscilloscope vertical channels for a deflection factor of 50 millivolts/division with the inputs DC coupled.

f. Remove the left side cover from the signal standardizer calibration fixture and install the calibration fixture in the A HORIZ compartment.

g. Set the calibration fixture Test switch to Vert or Horiz Gain and the Rep Rate switch to 100 kHz.

h. Position the test-oscilloscope display to align the bright center trace with the center horizontal line of the graticule.

i. ADJUST—A Horiz Gain adjustment R2323 (see Fig. 3-6) for exactly six divisions of deflection between the second and eighth traces.

j. Remove the calibration fixture and install it in the B HORIZ compartment.

k. Set the HORIZONTAL MODE switch to B.

l. Repeat parts h and i of this step; adjust B Horiz Gain adjustment R2313 (see Fig. 3-6) for the correct test-oscilloscope display.

m. Set the POWER switch to off.

n. Disconnect P4315 and P4316 from the test oscilloscope and connect each to its respective jack on the Horizontal Output board.

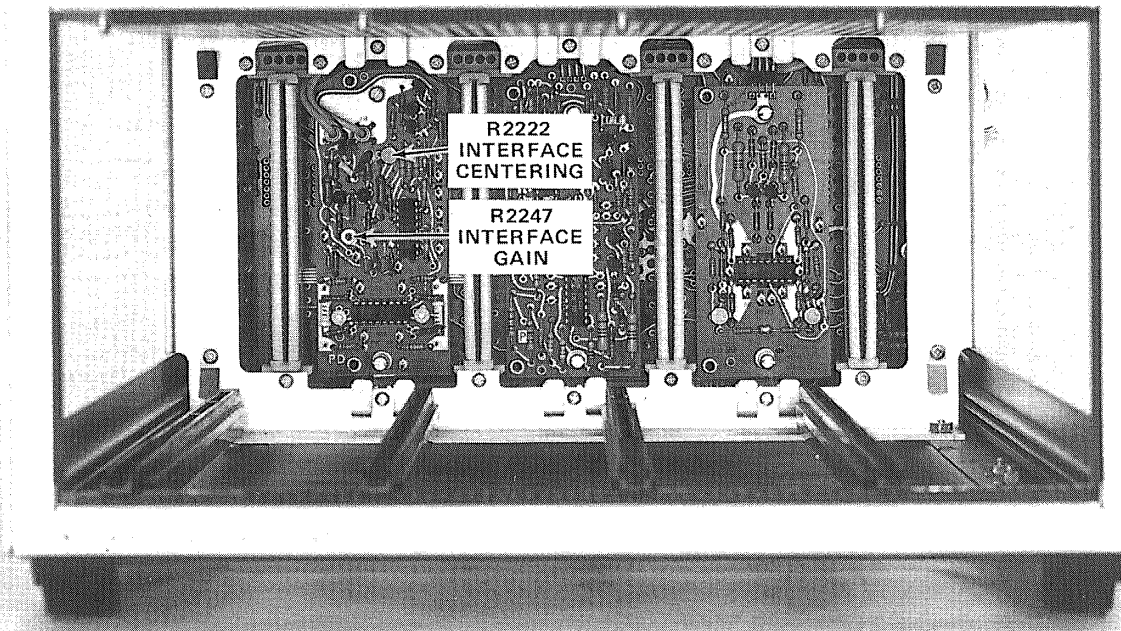

Fig. 3-4. Location of adjustments on A22, Vertical Interface board.

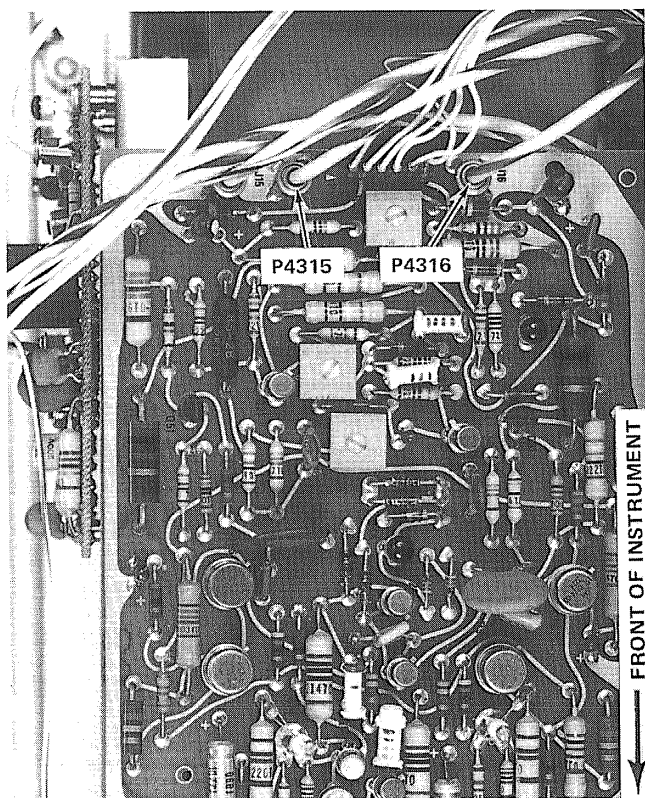

Fig. 3-5. Location of P4315 and P4316 on A43, Horizontal Output board.

CORRECTIVE MAINTENANCE

Corrective maintenance consists of component replacement and instrument repair. Special techniques required to replace components in this instrument are given here.

Soldering Techniques

WARNING

Disconnect the instrument from the power source before soldering.

The reliability and accuracy of this instrument can be maintained only if proper soldering techniques are used when repairing or replacing parts. General soldering techniques which apply to maintenance of any precision electronic equipment should be used when working on this instrument. Use only 60/40 rosin-core, electronic-grade solder. The choice of soldering iron is determined by the repair to be made. When soldering on circuit boards, use a 35- to 40-watt pencil-type soldering iron with a 1/8-inch wide, wedge-shaped tip. Keep the tip properly tinned for best heat transfer to the solder joint. A higher wattage soldering iron may separate the wiring from the base material. Avoid excessive heat; apply only enough heat to

remove the component or to make a good solder joint. Also, apply only enough solder to make a firm solder joint; do not apply too much solder.

CAUTION

Several of the circuit boards in this instrument are multi-layer type boards with a conductive path (s) laminated between the top and bottom board layers. All soldering on these boards should be done with extreme care to prevent breaking the connections to the center conductor(s); only experienced maintenance personnel should attempt repair of these boards.

For metal terminals (e.g., switch terminals, potentiometers, etc.), a higher wattage-rating soldering iron may be required. Match the soldering iron to the work being done. For example, if the component is connected to the chassis or other large heat-radiating surface, it will require a 75-watt or larger soldering iron. The pencil-type soldering iron used on the circuit board can be used for soldering to switch terminals, potentiometers, or metal terminals mounted in plastic holders.

Component Replacement

WARNING

Disconnect the instrument from the power source before replacing components.

General. The exploded-view drawing associated with the Mechanical Parts List (Section 7) may be helpful in the removal or disassembly of individual components or sub-assemblies. Figure 6-2 in the Diagrams section shows the location of circuit boards within the 7704A.

Power-Unit Removal. The power unit can be slid out of the rear of the 7704A to gain better access to the Logic circuit board and for power-unit maintenance. To remove the power unit, first remove the four screws which hold the power unit to the rear frame of the instrument. Slide the power unit out of the rear of the instrument until it can be set on the work surface (guide the cables so they do not catch on other parts of the instrument). The power unit remains connected to the rest of the instrument so it can be operated in this position for troubleshooting. Reverse this procedure when replacing the power unit; be careful not to pinch the power cables as the power unit is replaced. Be sure that all the securing screws are tight to hold the power unit in place properly.

WARNING

Extreme caution must be used when troubleshooting in the power supply due to the line voltage, high voltage and high current potentials present. Refer to the discussion entitled Access to Components in Power Unit for information on how to remove the protective cover from the power unit.

Access to Components in Power Unit. To reach the components located inside the power unit for maintenance or repair, use the following procedure:

WARNING

Disconnect the instrument from the power source before removing the power-unit cover. The primary storage capacitors, C3016 and C3017, remain charged with high voltage DC for several minutes after the line power is disconnected. A warning indicator (neon bulb), located on A30, Power Supply board, flashes when this stored voltage exceeds about 80 volts. Do not remove the power-unit cover while this light is flashing.

1. Slide out the power unit as described previously.
2. Remove the four small screws that secure the cover to the rear heat sink.

3. Remove the two screws that attach each side of the cover to the power unit.

4. Disconnect the two coaxial connectors from J12 and J13 on A31, Rectifiers and Filter board.

5. Remove the cover from the power unit.

6. The power unit is now open for maintenance or repair. If the 7704A is to be operated with the cover removed, first reconnect the coaxial cables to A31, Rectifiers and Filter board.

7. Reverse the order of removal to replace the power-unit cover.

Disassembly of Acquisition and Display Units. The (A7704) Acquisition and (D7704) Display units can be disassembled to gain access to the front-panel controls. To disassemble the two units, first disconnect the instrument from the power source. Remove the side panels as described previously. Unplug the Interface Connector (located on the right side of 7704A; see Fig. 3-7) and place it on the storage fixture. Remove the two screws which attach the units on each side (see Fig. 3-7). The two units can now be separated. To assemble the units, reverse the disassembly procedure.

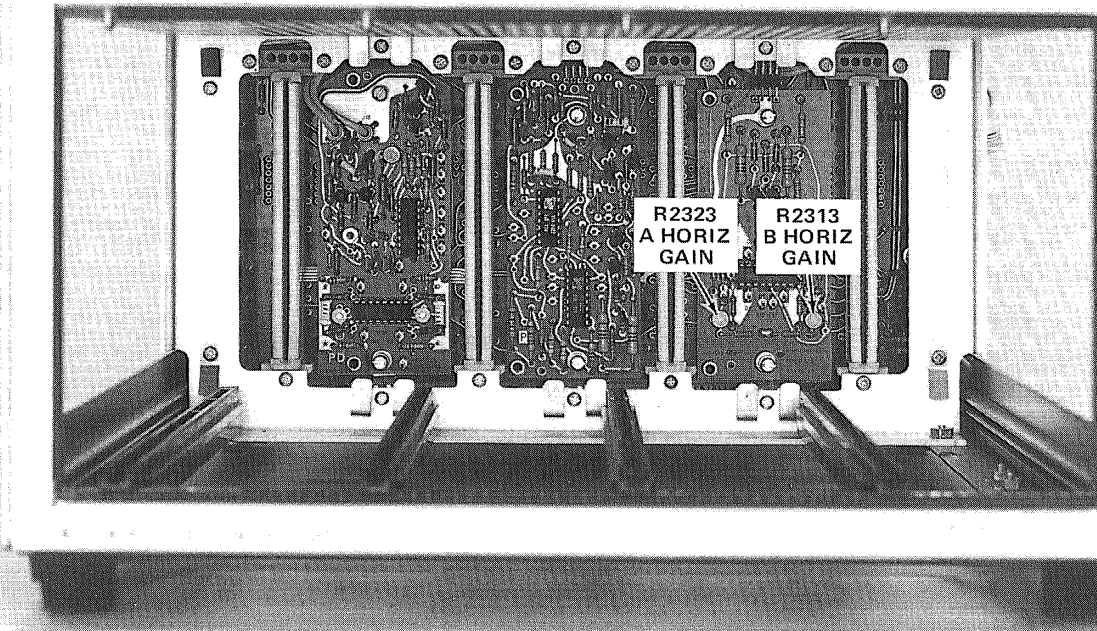

Fig. 3-6. Location of adjustments on A23, Horizontal Interface board.

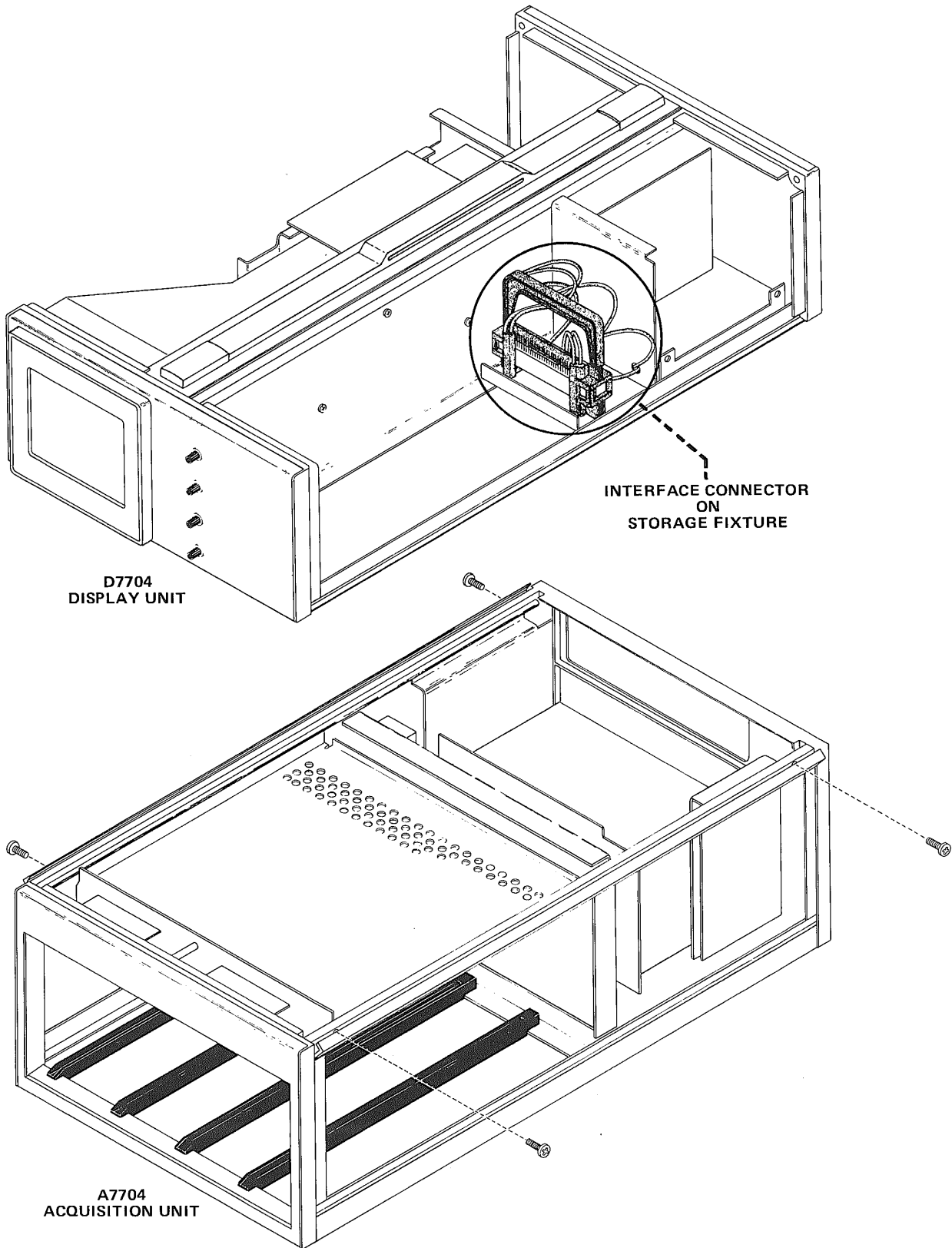

Fig. 3-7. Disassembly and assembly of Display and Acquisition units.

Circuit Board Replacement. If a circuit board is damaged beyond repair, replace the entire assembly including all soldered-on components. Part numbers for completely wired circuit boards are given in the Mechanical Parts List.

Most of the circuit boards in this instrument are mounted on the chassis; pin connectors are used for most interconnections with other circuit boards and components. Several boards plug onto the front and rear of the Main Interface board; feed-through connectors connect the plug-on boards to the Main Interface board. Use the following procedure to remove the chassis-mounted circuit boards (removal instructions for plug-on boards and boards requiring unique removal procedures will be given later).

The location of the pin connectors is shown on the circuit-board illustrations in the Diagrams section. Correct orientation of multi-pin connectors is indicated by an arrow molded into the connector housing (pin 1); a matching arrow is marked on the circuit board. Be sure these arrows are aligned as the multi-pin connector is replaced.

A. CHASSIS-MOUNTED BOARDS.

1. Disconnect all pin connectors or leads connected to the board or which connect the board to other portions of the instrument.
2. Remove the securing screws.
3. Remove the board.
4. To replace the board, reverse the order of removal. Match the arrows on the multi-pin connectors to the arrows on the board.

B. PLUG-ON BOARDS.

1. Remove plug-in units or slide out the power unit (as given previously) as necessary to gain access to boards mounted on the front or rear respectively of the Main Interface board.
2. Disconnect any coaxial end-lead or multi-pin connectors located on the board.
3. Loosen all of the securing screws on the board.
4. Pull out on the edges of the board until the board clears the feed-thru terminals. Hold the board parallel to the Main Interface board until the board is free, so as not to bend the feed-thru terminals.

5. To replace a plug-on circuit board, position it so the feed-thru pins and sockets mate properly.

6. Gently press the circuit board against the mounting surface. Be sure that all the feed-thru pins and sockets mate properly.

7. Uniformly tighten the securing screws. Recommended torque, four to six inch-pounds.

C. A20—MAIN INTERFACE CIRCUIT BOARD.

Use the following procedure to replace the Main Interface circuit board:

1. Disassemble the Display Unit from the Acquisition Unit (as given previously).

2. Slide out the power unit as described previously.

3. Remove all of the plug-on boards from the Main Interface board.

4. Disconnect all connectors which connect the Main Interface board to other portions of the Acquisition Unit.

5. Remove the screws from inside each plug-in compartment which hold the plug-in interface connectors to the chassis. Also, remove the screws which hold the ground straps to the chassis.

6. Slide the Main Interface board assembly to the rear and remove it through the top of the Acquisition Unit.

7. To replace the Main Interface board assembly, reverse the order of removal. Match the arrows on the pin connectors to the arrows on the board. Correct location of the pin connectors is shown in the circuit-board illustrations in the Diagrams section.

D. A10—CALIBRATOR BOARD.

To replace the Calibrator circuit board, proceed as follows:

1. Disassemble the Display Unit from the Acquisition Unit as described previously.

2. Loosen the setscrews securing the three front-panel knobs (use 1/16-inch hex-key wrench). Remove the knobs.

Maintenance—7704A Service

3. Disconnect all pin connectors from the board.
4. Remove the screws which hold the Calibrator board to the spacers.
5. Remove the Calibrator board with the mode switches from the unit. The mode switches can be unplugged from the Calibrator board.
6. To replace the Calibrator board, first plug the mode switches into their sockets on the board.
7. Position the Calibrator board so the front-panel controls and switches align with the hole in the front panel.
8. Replace the securing screws and front-panel knobs.
9. Connect the pin connectors to the Calibrator board. Match the arrows on the connectors to the arrows on the board. Correct location of the connectors is shown in the circuit-board illustration in the Diagrams section.

E. A34—READOUT BOARD OR A33—SIGNAL OUT BOARD.

The Readout and Signal Out boards are mounted on subassemblies. Either of these boards can be removed using the following procedure:

1. Disconnect the pin connectors from the circuit board.
2. Remove the two screws holding the subassembly to the rear panel of the Acquisition Unit.
3. Remove the entire subassembly from the unit.
4. To remove the board from the subassembly, disconnect the leads to the rear panel jacks and remove the securing screws.
5. To replace either board, reverse the removal procedure. Match the arrows on the connectors to the arrows on the board. Correct location of the pin connectors is shown in the circuit-board illustration in the Diagrams section.

F. A32—REGULATOR BOARD

To remove and replace the Regulator board, use the following procedures:

REMOVAL:

1. Slide the power unit out of the rear of the instrument as described previously.
2. Disconnect the multi-pin connectors from the board.
3. Remove the mounting hardware securing the plastic-cased power transistors to the rear heat sink. Note the orientation of the lockwashers so they can be correctly replaced.
4. Remove the screws which hold the Regulator board to the top chassis.
5. Disconnect the leads soldered to the back of the circuit board. Note the location of these leads so they can be correctly replaced. Remove the excess solder from the board with a vacuum-type desoldering tool.
6. Remove the Regulator board along with the plastic-cased transistors.

REPLACEMENT:

1. Connect the leads to the back of the circuit board.
2. Apply a thin coat of silicone grease to the back (mounting surface) of each plastic power transistor case.
3. Place the Regulator board on the chassis. Replace the screws which hold the board to the chassis; do not tighten these screws at this time.
4. Check that the plastic-cased power transistors are aligned with their mounting holes and that the insulating washers are in place between the transistor case and the rear heat sink.
5. Secure the transistors to the heatsink with the mounting hardware. Do not over-tighten the nuts; recommended torque is four to six inch-pounds.
6. Tighten the screws holding the Regulator board to the chassis.

7. Connect the multi-pin connectors to the board. Match the arrows on the connectors to the arrows on the board.

8. Replace the power unit in the instrument.

G. A31—RECTIFIER AND FILTER BOARD.

To remove the Rectifier and Filter board, use the following procedure. An exploded-view drawing of the power unit is shown in the Mechanical Parts List. Also, several critical parts are identified in Fig. 3-8, an exploded-view drawing of a portion of the power unit.

1. Slide the power unit out of the instrument as described previously.

2. Remove the protective cover from the power unit as described under Access to Components in Power Unit.

3. Disconnect the multi-pin connectors from A32, Regulator board, and A31, Rectifier and Filter board.

4. Remove the two plastic screws which secure the circuit-board shield in place on A30, Power Supply Inverter board.

5. Unsolder the four power-transformer leads from A30, Power Supply Inverter board. These leads, which pass through holes in the board, are identified on the circuit-board illustration in the Diagrams section. Remove the excess solder from the board with a vacuum-type desoldering tool.

6. Remove the four screws securing A31, Rectifier and Filter board to the power unit.

7. Remove the circuit board along with the power transformer.

8. To replace A31, Rectifier and Filter board, reverse the removal procedure.

H. A30—POWER SUPPLY INVERTER BOARD.

To remove the Power Supply Inverter board, use the following procedure. An exploded-view drawing of the power unit is shown in the Mechanical Parts List. Several critical parts are identified in Fig. 3-8, an exploded-view drawing of a portion of the power unit.

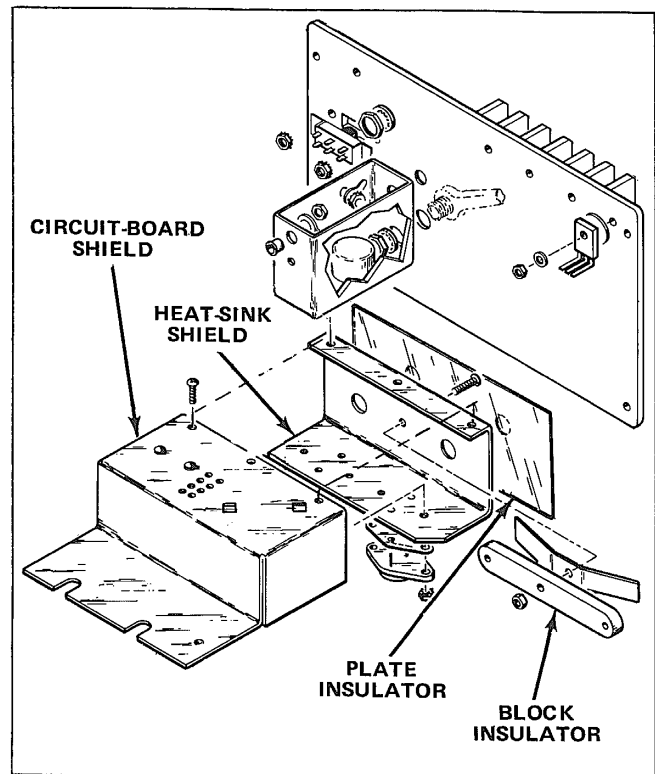

Fig. 3-8. Exploded-view drawing of a portion of the power unit identifying several critical parts.

WARNING

The power-unit assembly has been tested at the factory to assure safe operation. Improper repair of this unit can result in hazardous voltages on the chassis of this instrument. Do not remove the plate insulator, block insulator, or transistor shield from the rear heat sink (see Fig. 3-8).

1. Remove A31, Rectifier and Filter board using the previous procedure.

2. Remove the screws which attach A30, Power Supply Inverter board, to the rest of the power unit.

3. Unsolder the line-input leads from the circuit board. These leads are identified on the circuit-board illustration in the Diagrams section. Remove the excess solder from the board with a vacuum-type desoldering tool.

4. Remove the two metal-cased power transistors by removing the securing nuts and pulling the transistors from their sockets.

5. Move A30, Power Supply Inverter board, away from the heat sink shield until the transistor mounting studs clear the heat sink shield. Remove the Power Supply Inverter board from the power unit.

6. To replace the Power Supply Inverter board, reverse the removal procedure. Correct connection of the line-input leads is shown on the circuit-board illustration in the Diagrams section.

Plug-In Interface Connectors. The individual contacts of the plug-in interface connectors can be replaced. However, it is recommended that the entire Main Interface board be replaced if a large number of the contacts are damaged. An alternative solution is to refer the maintenance of the damaged Main Interface board to your local Tektronix Field Office or representative. Use the following procedure to replace an individual contact of the plug-in interface connector.

1. Remove the Main Interface circuit board from the instrument as described previously.
2. Snap the connector cover (white plastic) off the side of the plug-in interface connector which needs repair.
3. Unsolder and remove the damaged contact.
4. Install the replacement contact. Carefully form it to the required shape to fit against the connector body.
5. Snap the connector cover back onto the plug-in interface connector. Check that the contact which was replaced is aligned with the other contacts.
6. Replace the Main Interface board.

Semiconductor Replacement. Semiconductors should not be replaced unless actually defective. If removed from their sockets during routine maintenance, return them to their original sockets. Unnecessary replacement of semiconductors may affect the calibration of this instrument. When semiconductors are replaced, check the operation of the part of the instrument which may be affected.

CAUTION

POWER switch must be turned off before removing or replacing semiconductors.

Replacement semiconductors should be of the original type or a direct replacement. The lead configuration of the semiconductors used in this instrument are shown adjacent to or on each diagram page. Some plastic case transistors have lead configurations which do not agree with those shown here. If a replacement transistor is made by a different manufacturer than the original, check the manufacturer's basing diagram for correct basing. All transistor sockets in this instrument are wired for the standard basing used for metal-case transistors. Transistors which have heat radiators or are mounted on the chassis use silicone grease to increase heat transfer. Replace the silicone grease when replacing these transistors.

WARNING

Handle silicone grease with care. Avoid getting silicone grease in the eyes. Wash hands thoroughly after use.

An extracting tool should be used to remove the 14- and 16-pin integrated circuits to prevent damage to the pins. This tool is available from Tektronix, Inc. Order Tektronix Part No. 003-0619-00. If an extracting tool is not available when removing one of these integrated circuits, pull slowly and evenly on both ends of the device. Try to avoid having one end of the integrated circuit disengage from the socket before the other, as the pins may be damaged.

To replace one of the power transistors mounted on the heat radiator on the rear of the power unit, first remove the mounting screws. Then, unsolder and remove the defective transistor. When replacing the transistor, be sure to install the insulating washer between the transistor and the heat radiator (use silicone grease as described previously). Tighten the mounting screw just tight enough to hold the transistor in place. Then solder the replacement transistor to the Regulator board.

Interconnecting Pin Replacement. Two methods of interconnection are used in this instrument to connect the circuit boards with other boards and components. When the interconnection is made with a coaxial cable, a special end-lead connector plugs into a socket on the board. Other interconnections are made with a pin soldered onto the board. Two types of mating connections are used for these interconnecting pins. If the mating connector is on the end of a lead, an end-lead pin connector is used which mates with the interconnecting pin. The following information provides the replacement procedure for the various types of interconnecting methods.

A. COAXIAL-TYPE END-LEAD CONNECTORS.

Replacement of the coaxial-type end-lead connectors requires special tools and techniques; only experienced maintenance personnel should attempt replacement of these connectors. It is recommended that the cable or wiring harness be replaced as a unit. For cable or wiring harness part numbers, see the Mechanical Parts List. An alternative solution is to refer the replacement of the defective connector to your local Tektronix Field Office or representative.

B. CIRCUIT-BOARD PINS.

NOTE

A circuit-board pin replacement kit including necessary tools, instructions, and replacement pins is available from Tektronix, Inc.

To replace a pin which is mounted on a circuit board, first disconnect any pin connectors. Then, unsolder the damaged pin and pull it out of the circuit board with a pair of pliers. Be careful not to damage the wiring on the board with too much heat. Ream out the hole in the circuit board with a 0.031-inch drill. Remove the ferrule from the new interconnecting pin and press the new pin into the hole in the circuit board. Position the pin in the same manner as the old pin. Then, solder the pin on both sides of the circuit board. If the old pin was bent at an angle to mate with a connector, bend the new pin to match the associated pins.

C. CIRCUIT-BOARD PIN SOCKETS.

The pin sockets on the circuit boards are soldered to the rear of the board. To replace one of these sockets, first unsolder the pin (use a vacuum-type desoldering tool to remove excess solder). Then straighten the tabs on the socket and remove it from the hole in the board. Place the new socket in the circuit-board hole and press the tabs down against the board. Solder the tabs of the socket to the circuit-board; be careful not to get solder into the socket.

NOTE

The spring tension of the pin sockets ensures a good connection between the circuit board and the pin. This spring tension can be destroyed by using the pin sockets as a connecting point for spring-loaded probe tips, alligator clips, etc.

D. END-LEAD PIN CONNECTORS.

The pin connectors used to connect the wires to the interconnecting pins are clamped to the ends of the associated leads. To replace damaged end-lead pin connectors, remove the old pin connector from the end of the lead and clamp the replacement connector to the lead.

Some of the pin connectors are grouped together and mounted in a plastic holder; the overall result is that these

connectors are removed and installed as a multi-pin connector. To provide correct orientation of this multi-pin connector when it is replaced, an arrow is stamped on the circuit board and a matching arrow is molded into the plastic housing of the multi-pin connector. Be sure these arrows are aligned as the multi-pin connector is replaced. If the individual end-lead pin connectors are removed from the plastic holder, note the color of the individual wires for replacement.

Cathode-Ray Tube Replacement. To replace the cathode-ray tube, proceed as follows:

WARNING

The crt may retain a dangerous electrical charge. Before removing the crt, the anode must be fully discharged by shorting the anode lead from the crt to the chassis. Wait approximately ten minutes and again firmly short this lead to the chassis. Then remove the crt. After removal, short the anode lead to the silvered patch on the funnel portion of the crt just prior to further handling.

Use care when handling a CRT. Protective clothing and safety glasses should be worn. Avoid striking it on any object which might cause it to crack or implode. When storing a CRT, place it in a protective carton or set it face down in a protected location on a smooth surface with a soft mat under the faceplate to protect it from scratches.

A. REMOVAL:

1. Remove the plastic CRT mask, light filter, and metal light shield.
2. Remove the four screws securing the CRT bezel to the front panel. Disconnect the multi-pin connector from the left rear of the CRT bezel.
3. Release the CRT anode lead from the plastic fasteners near the top center of the instrument. Disconnect the anode plug from the jack on the high-voltage compartment. Ground this lead to the chassis to dissipate any stored charge.
4. Disconnect the deflection-plate connectors. Be careful not to bend these pins.
5. Remove the CRT base socket from the rear of the CRT.
6. Loosen the two screws located on each side of the CRT socket until the tension of the springs on these screws is released. Then, press in on the screws to be sure that the CRT clamp is loose.

Maintenance—7704A Service

7. Hold one hand on the CRT faceplate and push forward on the CRT base with the other. As the CRT starts out of the shield, grasp it firmly. Guide the anode lead through the cutout in the CRT shield as the CRT is removed.

B. REPLACEMENT:

1. Insert the CRT into the shield. Guide the anode lead through the hole in the CRT shield. Set the CRT firmly against the cushions mounted on each corner of the frame panel.

2. Clean the CRT faceplate, plastic faceplate protector, and the light filter with denatured alcohol.

3. Place the black plastic CRT mask over the CRT faceplate.

4. Reconnect the multi-pin connector to the CRT bezel (align arrow on connector with arrow on bezel). Hold the clear faceplate protector in position and install the CRT bezel. Firmly tighten the four screws.

5. Push forward on the CRT base to be certain that the CRT is as far forward as possible. Then tighten the two screws beside the CRT base socket until the springs on the screws are fully compressed.

6. Replace the CRT base socket.

7. Fasten the CRT anode lead into the plastic fasteners. Reconnect the CRT anode plug.

8. Carefully reconnect the deflection-plate connectors. After each connector is installed, lightly pull on its lead to be sure that it will remain in place.

9. Replace the metal light shield and the tinted filter. Then snap the plastic CRT mask into the CRT bezel.

10. Check the calibration of the complete instrument. Calibration procedure is given in Section 4.

Switch Replacement. Several types of switches are used in this instrument. The pull and slide switches should be replaced as a unit if damaged. Observe the soldering

precautions given previously in this section when replacing these switches. The following special maintenance information is provided for pushbutton switches.

The pushbutton switches are not repairable and should be replaced as a unit if defective. See the information under Light-Bulb Replacement for instructions on replacing the light bulbs. To replace a pushbutton switch, follow the procedure given for replacement of the Calibrator circuit board.

Light-Bulb Replacement. The following procedures describe replacement of the light bulbs in this instrument.

A. MODE SWITCHES.

Use the following procedure to replace light bulbs in the VERTICAL MODE or HORIZONTAL MODE switches:

1. Remove the applicable mode switch as given previously.

2. Unsolder the leads of the bulb and plastic holder from the circuit board; remove these items from the switch assembly as a unit.

3. Remove the defective bulb from the plastic holder.

4. Install the new bulb in the plastic holder; install this unit in the switch assembly.

5. Solder the bulb and holder to the circuit board.

6. Replace the mode switch as described previously.

B. TRIGGER SOURCE SWITCHES.

To replace light bulbs in the A TRIGGER SOURCE or B TRIGGER SOURCE switches, proceed as follows:

1. Remove the applicable trigger source switch, using the procedure described previously.

2. Unsolder the defective bulb from the circuit board.

3. Install the new bulb so it is positioned in the same manner as the original bulb.

4. Solder the bulb to the circuit board. If possible, use a heat sink to protect the bulb during soldering.

5. Install the switch using the procedure described previously.

C. GRATICULE BULB REPLACEMENT.

To replace the graticule bulbs, first remove the plastic CRT mask, light filter, and metal light shield. Pull on the white tabs to remove the graticule lamp assembly. Now, slide the lamp retaining strips to the side, off the bulb base. Pull the bulb out of the circuit board. Reverse the order of removal for replacement.

Power Transformer Replacement. Replace the power transformer only with a direct replacement Tektronix transformer. To replace the power transformer, proceed as follows:

1. Remove A31, Rectifier and Filter board, along with the power transformer as given under Circuit Board Replacement.

2. Unsolder the power-transformer leads from the Rectifier and Filter board. Remove the excess solder from the board with a vacuum-type desoldering tool.

3. Remove the brass spring retainers which hold the transformer windings and core in place and remove these items.

4. To replace the power transformer, reverse the order of removal.

Fuse Replacement. The fuses used in this instrument are as follows:

TABLE 3-2
Fuse Ratings

Circuit Number	Rating	Function	Location
F3001	4A Fast	Line Input	Line Selector Assembly
F3003	2A Fast	Inverter	Line Selector Assembly

Recalibration After Repair

After any electrical component has been replaced, the calibration of that particular circuit should be checked, as well as the calibration of other closely related circuits. Since the low-voltage supplies affect all circuits, calibration of the entire instrument should be checked if work has been done in the low-voltage supplies or if the power transformer has been replaced. See Section 4 for a complete calibration procedure.

Instrument Repackaging

If the Tektronix instrument is to be shipped to a Tektronix Service Center for service or repair, attach a tag showing: owner (with address) and the name of an individual at your firm that can be contacted, complete instrument serial number and a description of the service required.

Save and re-use the package in which your instrument was shipped. If the original packaging is unfit for use or not available, repackage the instrument as follows:

1. Obtain a carton of corrugated cardboard having inside dimensions of no less than six inches more than the instrument dimensions; this will allow for cushioning. Refer to the following table for carton test strength requirements.
2. Surround the instrument with polyethylene sheeting to protect the finish of the instrument.
3. Cushion the instrument on all sides by tightly packing dunnage or urethane foam between carton and instrument, allowing three inches on all sides.
4. Seal carton with shipping tape or industrial stapler.

SHIPPING CARTON TEST STRENGTH

Gross Weight (lb)	Carton Test Strength (lb)
0-10	200
10-30	275
30-120	375
120-140	500
140-160	600

CALIBRATION

Calibration Interval

To ensure instrument accuracy, check the calibration of the 7704A every 1000 hours of operation, or every six months if used infrequently. Before complete calibration, thoroughly clean and inspect this instrument.

Tektronix Field Services

Tektronix, Inc. provides complete instrument repair and recalibration at local Field Service Centers and the Factory Service Center. Contact your local Tektronix Field Office or representative for further information.

Using This Procedure

General. This procedure provides several features to facilitate calibration of the 7704A. These are:

Index. An index is given preceding the Calibration procedure to aid in locating steps.

Performance Check. The performance of this instrument can be checked by performing only the ✓ steps. The ✓ preceding a step indicates that performing this step checks the instrument against the tolerances listed as a Performance Requirement (see Specification section in 7704A Operators Manual). Limits and tolerances given in other check steps are calibration guides and should not be interpreted as instrument specifications. Operator front-panel adjustments are adjusted as part of the Performance Check procedure.

Partial Calibration. A partial calibration is often desirable after replacing components, or to touch up the adjustment of a portion of the instrument between major recalibrations. To calibrate only part of the instrument, start with the nearest Equipment Required list preceding the desired portion. To prevent unnecessary recalibration of other parts of the instrument, re-adjust only if the tolerance given in the CHECK — part of the step is not met. If re-adjustment is necessary, also check the calibration of any steps listed in the INTERACTION — part of the step.

Complete Calibration Procedure. Completion of each step in the Calibration procedure insures that this instrument is correctly adjusted and performing within all given tolerances.

TEST EQUIPMENT REQUIRED

The following test equipment and accessories, or equivalent, is required for complete calibration of the 7704A. Specifications given for the test equipment are the minimum necessary for accurate calibration. Therefore, the specifications of any test equipment used must meet or exceed the listed specifications. All test equipment is assumed to be correctly calibrated and operating within the listed specifications. Detailed operating instructions for the test equipment are not given in this procedure. Refer to the instruction manual for the test equipment if more information is needed.

Special Calibration Fixtures

Special Tektronix calibration fixtures are used in this procedure only where they facilitate instrument calibration. These calibration fixtures are available from Tektronix, Inc. Order by part number through your local Tektronix Field Office or representative.

Calibration Equipment Alternatives

All of the listed test equipment, or its equivalent, is required to completely check and adjust this instrument. The Calibration procedure is based on the first item of equipment given as an example of applicable equipment. When other equipment is substituted, control settings or calibration setup may need to be altered to meet the requirements of the substituted equipment. If the exact item of test equipment given as an example in the Test Equipment list is not available, first check the Specifications column carefully to see if any other equipment is available which might suffice. Then check the Usage column to see what this item of test equipment is used for. If used for a check or adjustment which is of little or no importance to your measurement requirements, the item and corresponding step(s) can be deleted.

The following procedure is written to completely check and adjust the 7704A to the Performance Requirements listed in the Operators Manual and to allow interchangeability of 7000-series plug-in units between 7000-series mainframes without the need to completely recalibrate the instruments each time. If the applications for which you will use the 7704A do not require the full available

performance from the 7704A and plug-in combinations, this procedure and the required equipment list can be shortened accordingly. For example, the basic measurement capabilities of this instrument can be verified by just checking vertical deflection accuracy and basic horizontal timing with 7000-series real-time plug-in units and the 7704A Calibrator signal. Also, if the 7704A and plug-in combination is to be used as a fixed system without the need to interchange the plug-in units, all tests can be made by substituting vertical plug-in units and applicable test signals for the 067-0587-01 signal standardizer calibration fixture.

Signal Connections

Detailed signal-connection information is not given in this procedure except when critical for a particular test. In general, the rear-panel output connectors should be connected to other equipment with 50-ohm BNC cables. The cable output should be terminated in 50 ohms; use a 50-ohm BNC termination if the other equipment has a high input impedance. Use a BNC T connector to simultaneously connect a signal to two inputs. Signal-connection and termination information for the test equipment should be available in the associated instruction manual.

TABLE 4-1
Test Equipment

Description	Minimum Specifications	Usage	Examples Of Applicable Test Equipment
1. Precision DC Voltmeter	Range, zero to 175 volts; accuracy, within 0.1%.	Low-voltage power supply adjustment. Calibrator output voltage adjustment.	a. Tektronix DM 501 Digital Multimeter. ¹ b. Fluke Model 825A Differential DC Voltmeter.
2. DC Voltmeter (VOM)	Range, zero to 4000 volts; accuracy, checked to within 1% at -2960 volts.	High-voltage power supply adjustment.	a. Triplet Model 630-NA. b. Simpson Model 262. c. Item 1 used with a precision voltage divider.
3. Signal Standardizer Calibration Fixture	Produces gain-check and pulse-response waveforms.	Used throughout procedure to standardize instrument so plug-in units can be interchanged without complete recalibration.	a. Tektronix 067-0587-01 Calibration Fixture. b. Calibrated 7000-series plug-in units with suitable signal sources may be substituted if lower performance is acceptable.
4. Time-Base Plug-In Unit (Two Required)	Tektronix 7B-series. X10 magnifier and two nanosecond/division sweep rate required for complete procedure as written.	Used throughout procedure to provide sweep. Two nanosecond/division sweep required only for high-frequency timing (one unit only).	a. Tektronix 7B70 or 7B71 Time Base. May be shared with 7000-series test oscilloscope. b. Any 7B-series plug-in unit (high-frequency timing cannot be checked if two nanosecond/division sweep rate not available).
5. Test-Oscilloscope System with 10X Probe	Bandwidth, DC to 75 megahertz; minimum deflection factor, 50 millivolts/division; accuracy, within 3%.	CRT grid bias adjustment. Z-axis transient response adjustment. Auto-focus adjustment. Output Signals checks.	a. Tektronix 7704A Oscilloscope with 7A15A Amplifier, 7B70 or 7B71 Time Base, and P6053 Probe. b. Tektronix 454A Oscilloscope with P6054 Probe.
6. Time-Mark Generator	Marker outputs, two nanoseconds to one millisecond; marker accuracy, within 0.1%; trigger output, one millisecond.	Geometry adjustment. High-frequency timing check. Calibrator 1 kHz repetition rate adjustment.	a. Tektronix TG 501 Time-Mark Generator. ¹ b. Tektronix Type 2901 Time-Mark Generator.
7. Low-Frequency Generator	Frequency, 50 kilohertz; output amplitude, variable from five millivolts to two volts peak-to-peak.	External Z-axis check. X-Y phase shift check.	a. Tektronix SG 503 Signal Generator. ¹ b. Tektronix Type 191 Constant Amplitude Signal Generator. c. General Radio 1310-B Oscillator.

¹ Requires TM 500-Series Power Module.

TABLE 4-1 (cont)

Description	Minimum Specifications	Usage	Examples of Applicable Test Equipment
8. Amplifier Plug-In Unit (two identical units required)	Tektronix 7A-series. Bandwidth with 7704A, DC to 200 megahertz required for complete procedure as written.	Used throughout procedure to provide vertical input to 7704A being calibrated. 200 megahertz bandwidth required only for vertical channel isolation check. Identical units required only for X-Y phasing check.	a. Tektronix 7A19 Amplifier. b. Tektronix 7A16A Amplifier. c. Any 7A-series plug-in (tolerances in some steps may be limited if low-frequency units are used).
9. High Frequency Constant-Amplitude Signal Generator	Frequency range, 100 megahertz to 250 megahertz (300 megahertz for Option 9); three megahertz; output amplitude, variable from 0.5 to four volts peak-to-peak; amplitude accuracy, constant within 1% of reference as output frequency changes.	Vertical channel isolation check. Vertical amplifier bandwidth check.	a. Wavetek 1002 Sweep/Signal Generator.
10. Screwdriver	Three-inch shaft. 3/32-inch bit.	Used throughout procedure to adjust variable resistors.	a. Xcelite R-3323.
11. Low-Capacitance Screwdriver	1-1/2 shaft.	Used throughout procedure to adjust variable capacitors.	a. Tektronix Part Number 003-0000-00.
12. T Connector	Connectors, BNC.	Used to simultaneously connect a signal to two inputs.	a. Tektronix Part Number 103-0030-00.
13. BNC to Pin-Jack Cable	Adapts pin jacks to BNC male connector.	Used to connect calibrator output to BNC inputs.	a. Tektronix Part Number 175-1178-00 (one supplied as standard accessory).

CALIBRATION PROCEDURE

7704A, Serial No. _____
 Calibration Date _____
 Calibrated By _____

Introduction

The following procedure returns the 7704A to correct calibration. All limits and tolerances given in this procedure are calibration guides, and should not be interpreted as instrument specifications except as listed as a Performance Requirement in the Operators manual.

Index to Calibration Procedure

Power Supply	Page
1. Adjust +54-Volt Supply	4-5
2. Adjust -50-Volt Power Supply	4-5
3. Check Remaining Power-Supply Voltages	4-5

Z-Axis and Display

4. Adjust High-Voltage Power Supply	4-7
5. Adjust CRT Grid Bias	4-7
6. Adjust Z-Axis Transient Response	4-8
√7. Adjust Trace Alignment	4-8
8. Adjust Auto-Focus Operation	4-8
9. Adjust Geometry	4-9
√10. Check External Z-Axis Operation	4-9

Vertical System

11. Adjust Vertical Amplifier Centering	4-10
12. Adjust Vertical Amplifier Bias	4-10
√13. Adjust Vertical Amplifier Gain	4-10
√14. Check Low-Frequency Linearity	4-11
15. Adjust Vertical High-Frequency Compensation	4-11

Calibration—7704A Service

	Page
√16. Check Vertical Amplifier Bandwidth	4-12
√17. Check Vertical Channel Isolation	4-12
√18. Check Vertical Display Modes	4-13
√19. Check Vertical Trace Separation Operation	4-13

Triggering

√20. Check Trigger Selector Operation	4-14
---------------------------------------	------

Horizontal System

√21. Adjust Horizontal Amplifier Gain	4-16
22. Adjust Horizontal Amplifier Centering	4-17
23. Adjust Horizontal Amplifier Thermal Balance	4-17
√24. Check Low-Frequency Linearity	4-17
√25. Adjust High-Frequency Timing	4-17
√26. Check X-Y Phase Shift	4-18

Calibrator

√27. Adjust Calibrator Output Voltage	4-19
√28. Adjust Calibrator 1 kHz Repetition Rate	4-19

Output Signals

√29. Check Sawtooth Output Signals	4-21
√30. Check Gate Output Signals	4-21
√31. Check Vertical Signal Output	4-22

Readout System

32. Adjust Vertical Separation	4-23
33. Adjust Full Character Scan	4-24

	Page
34. Adjust Column and Row Match	4-24
√35. Check Readout Modes	4-24

Preliminary Procedure for Calibration

NOTE

This instrument should be calibrated at an ambient temperature of $+25^{\circ}\text{C} \pm 5^{\circ}\text{C}$ for best overall accuracy.

1. Remove the side panels from the 7704A.

2. Connect the 7704A to a power source that meets the voltage and frequency requirements of this instrument. The applied voltage should be near the center of the voltage range selected by the Line Selector assembly (see Section 1 for information on converting this instrument from one operating voltage to another).

NOTE

If correct line voltage is not available, use a variable autotransformer to provide the correct input voltage.

3. Set the controls as given under Control Settings preceding the desired section. Allow at least 20 minutes warmup before proceeding with the first section.

NOTE

Titles for external controls of this instrument are capitalized in this procedure (e.g., A INTENSITY). Internal adjustments are initial capitalized only (e.g., Vertical Amplifier Gain).

NOTE

The assembly number is included as part of the circuit number of adjustments and test points used in this procedure. For example, R133 on assembly A32 is referred to as R32133.

POWER SUPPLY

Equipment Required

1. Precision DC voltmeter

2. Three-inch screwdriver

NOTE

The location of adjustments and test points for calibration is shown on a foldout, page 6-31, in the Diagrams section.

Control Settings

Set the 7704A controls as follows:

POWER	OFF
VERTICAL MODE	RIGHT
VERT TRACE	
SEPARATION (B)	Midrange
A TRIGGER SOURCE	VERT MODE
A INTEN	Midrange
HORIZONTAL MODE	A
B INTEN	Midrange
B TRIGGER SOURCE	VERT MODE
INTENSITY	Midrange
FOCUS	Midrange
READOUT	OFF
GRAT ILLUM	Midrange

1. Adjust +54-Volt Supply

a. Remove the screws securing the corners of the heat sink assembly to the rear of the instrument (the Line Selector assembly is mounted on the heat sink assembly). Slide the power unit out of the 7704A; the interconnecting cables remain connected.

WARNING

Extreme caution must be used when operating the 7704A with the power-unit cover removed due to the line voltage and high-voltage/high-current potentials present.

b. Return the POWER switch to on.

c. Connect the precision DC voltmeter between the +54 V test point (see Fig. 6-26) and ground.

d. CHECK—Meter reading; +54.2 volts ± 0.25 volt. (If the meter reading is within the given tolerance, do not re-adjust; otherwise, perform part e.)

e. ADJUST—+54-V adjustment R3143 (bottom of power supply, accessible through the cover near the front of the power unit; see Fig. 6-27) for a meter reading of +54.2 volts.

f. Disconnect the precision DC voltmeter.

g. INTERACTION—If the setting of R3143 is changed, check steps 2, 3, and 4.

2. Adjust -50 Volt Power Supply

a. Connect the precision DC voltmeter between the -50 V supply and chassis ground (pin 6-P32G; see Fig. 6-28).

b. CHECK—Meter reading; -50 volts ± 0.2 volt.

c. ADJUST -50 V adjustment R32133 (see Fig. 6-28) for a meter reading of -50 volts ± 0.2 volt.

d. INTERACTION—Any change in the setting of R32133 may affect operation of all circuits within the 7704A and plug-in units.

3. Check Remaining Power-Supply Voltages

a. CHECK—Table 4-2 lists the low-voltage power supplies in the instrument. Check each supply with the precision DC voltmeter for output voltage within the given tolerance.

Calibration—7704A Service

b. Set the POWER switch to off and disconnect all test equipment.

c. Install the power unit in the instrument and return the POWER switch to on.

d. Connect the precision DC voltmeter to Pin 1 of P43 on rear of A43, Horizontal Output board; see Fig. 6-29.

e. CHECK—Meter reading +155 volts \pm 5 volts.

f. Disconnect all test equipment.

TABLE 4-2
Power Supply Tolerance

Power Supply	Output Voltage Tolerance	Test Point Location (see Fig. 6-28)
-50 Volt	\pm 0.20 volt	Pin 6—P32G
-15 Volt	\pm 0.15 volt	Pin 1—P32G
+5 Volt	\pm 0.10 volt	Pin 2—P32G
+15 Volt	\pm 0.15 volt	Pin 4—P32G
+50 Volt	\pm 0.50 volt	Pin 5—P32G
Control Illum (+5 V Lights)	+0.2 to -0.5 volt	Pin 9—P32G

Z-AXIS AND DISPLAY

Equipment Required

- | | |
|--|--|
| 1. DC voltmeter (VOM) | 5. Test oscilloscope system with 10X probe |
| 2. Signal standardizer calibration fixture | 6. Time-mark generator |
| 3. Time-base plug-in unit (two required) | 7. Low-frequency signal generator |
| 4. Amplifier plug-in unit | 8. Three-inch screwdriver |
| | 9. Low-capacitance screwdriver |

NOTE

The location of adjustments and test points for calibration is shown on a foldout, page 6-33, in the Diagrams section.

Control Settings

Set the 7704A controls as follows:

POWER	OFF
VERTICAL MODE	RIGHT
VERT TRACE SEPARATION (B)	Midrange
A TRIGGER SOURCE	VERT MODE
A INTEN	Fully clockwise
HORIZONTAL MODE	A
B INTEN	Fully clockwise
B TRIGGER SOURCE	VERT MODE
INTENSITY	Fully counterclockwise
FOCUS	Midrange
READOUT	OFF
GRAT ILLUM	Midrange

4. Adjust High-Voltage Power Supply

a. Connect the DC voltmeter (VOM), set to measure at least 3000 volts, between TP4221 and chassis ground (see Fig. 6-30).

b. Set the POWER switch to on.

c. CHECK—Meter reading; $-2960 \text{ volts} \pm 29.6 \text{ volts}$.

d. ADJUST—High Voltage adjustment R4123 (see Fig. 6-31) for a meter reading of -2960 volts .

e. Set the POWER switch to off and disconnect the voltmeter. Return the POWER switch to on.

5. Adjust CRT Grid Bias

a. Install the signal standardizer calibration fixture in the RIGHT VERT compartment and a time-base unit in the A HORIZ compartment.

b. Set the time-base unit for a free-running sweep at a rate of 0.2 second/division. Set the calibration fixture Test switch to Triggering Gain.

c. Connect the 10X probe to the input of the test oscilloscope. Check the probe compensation.

d. Set the test oscilloscope for a vertical deflection factor of 0.2 volt/division (two volts/division at probe tip) and a sweep rate of one millisecond/division.

e. Establish a ground reference level for the test oscilloscope by either grounding the probe tip or setting the input coupling to ground. Then, position the test oscilloscope trace to the bottom horizontal line of the graticule. Do not change the test-oscilloscope position control after setting this ground reference.

f. Connect the probe tip to TP41120 (see Fig. 6-31); connect the probe ground to chassis ground with a short grounding strap.

g. Note the DC level indicated by the test-oscilloscope trace.

h. Set the INTENSITY control for a DC level four volts more positive than the level noted in part g.

Calibration—7704A Service

i. ADJUST—CRT Grid Bias adjustment R4135 (see Fig. 6-31) so the dot on the CRT screen is just extinguished.

j. Leave the 10X probe connected to TP 41120 for the next step.

6. Adjust Z-Axis Transient Response

a. Set the test oscilloscope for a vertical deflection factor of one volt/division (10 volts/division at probe tip) at a sweep rate of two microseconds/division.

b. Set the time-base unit for a free-running sweep at a rate of 0.02 microsecond/division.

c. Set the INTENSITY control for a pulse waveform with a peak-to-peak amplitude of 30 volts as displayed on the test oscilloscope.

d. Set the test oscilloscope for a sweep rate of 20 nanoseconds/division.

e. CHECK—Test oscilloscope for optimum square corner on displayed pulse.

f. ADJUST—Z-Axis Peaking adjustment R4197 and C41109 (see Fig. 6-31) for optimum square corner on displayed pulse.

g. Disconnect all test equipment.

√7. Adjust Trace Alignment

a. Change the following control settings:

VERTICAL MODE	ALT
HORIZONTAL MODE	CHOP

b. Install a time-base unit in the LEFT VERT compartment and an amplifier unit in the B HORIZ compartment.

c. Set both time-base units for auto, external triggering at a sweep rate of 0.1 millisecond/division.

d. Set the calibration fixture Test switch to Vert or Horiz Freq Response.

e. Position the traces to the vertical and horizontal center lines of the graticule. Use the calibration fixture Position control to position the vertical trace and the amplifier unit position control to position the horizontal trace.

√f. CHECK—The vertical trace aligns with the center vertical line within 0.1 division and the horizontal trace aligns with the center horizontal line within 0.1 division.

√g. ADJUST—Front-panel TRACE ROTATION adjustment (horizontal alignment) and Y Axis Align adjustment (vertical alignment) R41173 (see Fig. 6-31) so the traces align with the vertical and horizontal center lines.

h. INTERACTION—Check step 8.

8. Adjust Auto-Focus Operation

a. Set the calibration fixture Test switch to Vert or Horiz + Step Resp, and the Rep Rate switch to 10 kHz.

b. Set the time-base unit for auto, internal triggering at a 0.1-microsecond/division sweep rate (left compartment).

c. Set the calibration fixture for a three-division display.

d. Set the INTENSITY control for a low-intensity display. Set the FOCUS control and ASTIG adjustment for a well-defined display.

e. Set the INTENSITY control for maximum display intensity.

f. ADJUST—Auto Focus Gain adjustment R41127 (see Fig. 6-31) for a well-defined, high-intensity display.

g. Set the INTENSITY control for a low-intensity display.

h. Connect the test oscilloscope 10X probe tip to the junction of R41131-CR41157-R41155-CR41155 (see Fig. 6-31).

i. Set the test oscilloscope for a vertical deflection factor of one volt/division (10 volts/division at probe tip), and a sweep rate of 200 nanoseconds/division.

j. While observing the test-oscilloscope display, rotate the INTENSITY control between the minimum and maximum display-intensity levels. If necessary, reposition the gimmick-capacitor wire located around R41131 (see Fig. 6-31) for best square corner on displayed pulse throughout the rotation of the INTENSITY control.

k. INTERACTION—Check step 6.

l. Disconnect the probe.

9. Adjust Geometry

a. Change the following control settings:

VERTICAL MODE	RIGHT
HORIZONTAL MODE	A

b. Connect the marker output of the time-mark generator to the calibration fixture Aux In connector and the trigger output to the A time-base unit external trigger input.

c. Set the time-mark generator for one-millisecond markers and one-millisecond triggers.

d. Set the A time-base unit for auto triggering from the external source at a sweep rate of 0.5 millisecond/division.

e. Set the calibration fixture Test switch to Vert or Horiz Aux In. Set the Amplitude and Position controls so the time markers extend above and below the upper and lower graticule limits.

f. Set the time-base unit variable time/division control to obtain exactly one marker for each major graticule division.

g. Set the time-mark generator for both one- and 0.1-millisecond markers.

h. CHECK—Vertical bowing and tilt of the marker display is less than 0.1 division (each 0.1-millisecond marker represents 0.1 division).

i. ADJUST—Geometry adjustment R41171 (see Fig. 6-31) for minimum bowing of time markers. Adjustment might have to be compromised to obtain less than 0.1 division bowing and tilt everywhere within the graticule area.

j. Disconnect all test equipment.

9A. Adjust Shield Volts

a. Short the vertical deflection leads together with a jumper lead.

b. Connect the positive dc voltmeter lead to the deflection leads and note the reading.

c. Disconnect the positive voltmeter lead and remove the short.

d. Connect the positive dc voltmeter lead to pin 4 of P41U, on the Z-Axis board.

e. ADJUST—Shield Volts adjustment R41176 for approximately the same reading as obtained in part b of this step.

√10. Check External Z-Axis Operation

NOTE

If the Signal-Buffer subassembly was deleted from this instrument (Option 7) omit this step.

a. Remove the calibration fixture and install the amplifier unit in its place.

b. Connect the output of the low-frequency signal generator to the amplifier-unit input (use a BNC T connector at the amplifier input).

c. Set the amplifier unit for a calibrated deflection factor of 0.5 volt/division.

d. Set the A time-base unit for auto, internal triggering at a sweep rate of 10 microseconds/division.

e. Set the signal generator for a four-division display at 50 kilohertz.

f. Connect the signal from the output of the T connector at the amplifier input to the Z-AXIS INPUT connector on the rear panel.

√g. CHECK—Top portion of displayed waveform is blanked out.

h. Disconnect all test equipment and remove the plug-in units.

VERTICAL SYSTEM

Equipment Required

- | | |
|--|---|
| 1. Signal standardizer calibration fixture | 4. High-frequency constant-amplitude signal generator |
| 2. Time-base plug-in unit (two required) | 5. Three-inch screwdriver |
| 3. Amplifier plug-in unit (two required) | 6. Low-capacitance screwdriver |

NOTE

The location of adjustments is shown on a pullout, page 6-33, in the Diagrams section.

Control Settings

Set the 7704A controls as follows:

POWER	ON
VERTICAL MODE	ALT
VERT TRACE	
SEPARATION (B)	Midrange
A TRIGGER SOURCE	VERT MODE
A INTEN	Midrange
HORIZONTAL MODE	A
B INTEN	Midrange
B TRIGGER SOURCE	VERT MODE
INTENSITY	Midrange
FOCUS	Adjust for a well-defined display
READOUT	OFF
GRAT ILLUM	Midrange

NOTE

The Vertical Interface Centering and Gain adjustments do not need to be checked during routine calibration. However, if components are replaced or if the Acquisition Unit is used in a different system, adjustment might be necessary. The need for adjustment is indicated if the Vertical System adjustments can not be performed according to the following procedure. Calibration information for the Vertical Interface is given under Special Adjustment Procedures in the Maintenance section.

11. Adjust Vertical Amplifier Centering

- a. Install a time-base unit in the A HORIZ compartment.
- b. Set the time-base unit for a free-running sweep at a rate of 100 microseconds/division.

c. CHECK—CRT display; vertical position of alternating traces (might appear as a single trace) is within 0.2 division of the graticule center line.

d. ADJUST—Vertical Amplifier Centering adjustment R4493 (see Fig. 6-32) for equal spacing of the traces from the graticule center line. (If the traces appear as a single trace, adjust R4493 to position the trace to the graticule center line.)

12. Adjust Vertical Amplifier Bias

- a. Set the VERTICAL MODE switch to RIGHT.
- b. Install the signal standardizer calibration fixture in the RIGHT VERT compartment.
- c. Set the calibration fixture Test switch to Vert or Horiz Gain and the Rep Rate to 1 kHz.
- d. ADJUST—Vertical Amplifier Bias adjustment R4415 (see Fig. 6-32) for maximum deflection between the traces.

✓13. Adjust Vertical Amplifier Gain

- a. Set the calibration fixture for a Rep Rate of 100 kHz. Position the display to align the bright center trace with the graticule center line.
- ✓b. Check—Deflection between the second and eighth traces should be six divisions \pm 0.06 division. Note the exact deflection for part f of this step.
- c. ADJUST—Vertical Amplifier Gain adjustment R4406 (see Fig. 6-32) for exactly six divisions of deflection between the second and eighth traces.

d. Remove the calibration fixture from the RIGHT VERT compartment and install it in the LEFT VERT compartment.

e. Set the VERTICAL MODE switch to LEFT.

√f. CHECK—Deflection between the second and eighth traces should be the same as step 13b ±1% (six divisions ±0.06 division if R4406 was adjusted in step 13c).

g. ADJUST—If necessary, compromise the setting of R4406 for optimum gain for both vertical compartments. If re-adjustment is necessary, recheck parts b through f.

√14. Check Low-Frequency Linearity

a. Set the signal standardizer calibration fixture Test switch to Vert or Horiz +Step Resp with the Rep Rate switch set to 1 kHz.

b. Set the calibration fixture Amplitude control so the display is exactly two divisions in amplitude in the center of the graticule area.

√c. CHECK—Position the two-division display vertically and check for not more than 0.1 division of compression or expansion anywhere within the graticule area.

15. Adjust Vertical High-Frequency Compensation

a. Set the signal standardizer calibration fixture Rep Rate switch to 1 MHz. Set the Amplitude and Position controls for a six-division display, centered on the graticule.

b. Set the time-base unit for auto, internal triggering at a sweep rate of 100 nanoseconds/division. Set the triggering controls for a stable display triggered on the rising portion of the pulse.

c. CHECK—Check for optimum square corner and flat top on displayed pulse. Aberrations in the first 50 nanoseconds after the step are not to exceed +0.1 or -0.1 division with total peak-to-peak aberrations not to exceed 0.12 division; aberrations from 50 to 150 nanoseconds after the step are not to exceed 0.03 division peak-to-peak. (For Option 9: Aberrations in the first 50 nanoseconds after the step are not to exceed +0.3 or -0.3 division with total peak-to-peak aberrations not to exceed 0.3 division; aberrations from 50 to 150 nanoseconds after step are not to exceed 0.06 division peak-to-peak.)

d. ADJUST—High-frequency compensation as given in Table 4-3 for optimum square leading corner and flat top with minimum aberrations within limits given in part c. Location of the adjustments is shown in Figs. 6-32 and 6-33. Use the low-capacitance screwdriver to adjust variable capacitors. Adjust the inductors by changing their position in the sockets. Repeat the complete adjustment procedure as necessary to obtain optimum response.

e. Move the calibration fixture to the RIGHT VERT compartment and set the VERTICAL MODE switch to RIGHT.

f. CHECK—Check for optimum square corner and flat top on displayed pulse with aberrations within limits given in part c.

TABLE 4-3

High Frequency Compensation

Calibration Fixture Rep Rate	Best Sweep Rate (time/division)	Adjustment	Primary Area of Pulse Affected
100 Hz	2 milliseconds	R4465	First 10 microseconds (flat top)
1 kHz	0.2 millisecond	R4453	First five microseconds (flat top)
10 kHz	20 microseconds	R4461	First one microsecond (flat top)
100 kHz	2 microseconds	R4423	First 400 nanoseconds
1 MHz	100 nanoseconds	C4424	First 50 nanoseconds
1 MHz	50 nanoseconds	R4427-C4427	Five to 15 nanoseconds
1 MHz	20 nanoseconds	R4404-C4401	2 to 5 nanoseconds (leading edge)
1 MHz	2 nanoseconds	L4410-L4411	Front corner
1 MHz	2 nanoseconds	R2234-C2231	Front corner

Calibration—7704A Service

g. ADJUST—Interface high-frequency compensation R2284-C2281 (see Fig. 6-33) for optimum square leading corner and flat top on displayed pulse with minimum aberrations within limits given in part c. If necessary, compromise the adjustments given in Table 4-3 (except for C2231) for optimum pulse response for both vertical compartments. If re-adjustment is necessary, recheck parts c through f.

✓16. Check Vertical Amplifier Bandwidth

a. Connect the output of the high-frequency constant-amplitude signal generator to the calibration fixture CW In connector.

b. Set the calibration fixture Test switch to Vert or Horiz Freq Resp.

c. Set the time-base unit for a free-running sweep at a rate of 200 nanoseconds/division.

d. Set the high-frequency generator for eight divisions of deflection at its reference frequency.

e. Without changing the output amplitude, increase the output frequency of the generator until the display amplitude is reduced to 5.6 divisions (−3 dB point).

✓f. CHECK—Generator output frequency must be 230 megahertz or higher (210 megahertz if checked outside the +20°C to +30°C temperature range). Actual frequency (RIGHT VERT) megahertz. (Option 9: Generator output frequency must be 280 megahertz or higher within the +20°C to +30°C temperature range, or 210 megahertz outside this range.)

g. Move the calibration fixture to the LEFT VERT compartment, and set the VERTICAL MODE switch to LEFT.

✓h. Repeat parts d through f. Actual frequency (LEFT VERT) megahertz.

✓17. Check Vertical Channel Isolation

a. Replace the signal standardizer calibration fixture with the amplifier unit.

b. Connect the output of the high-frequency signal generator to the amplifier unit input.

c. Set the amplifier unit and signal generator for an eight-division display at 100 megahertz.

d. Set the VERTICAL MODE switch to RIGHT.

✓e. CHECK—CRT display for not more than 0.1 division of 100-megahertz signal (channel isolation at least 100:1 at 100 megahertz).

f. Set the VERTICAL MODE switch to LEFT.

g. Set the generator for an eight-division display at 200 megahertz.

h. Set the VERTICAL MODE switch to RIGHT.

✓i. CHECK—CRT display for not more than 0.2 division of 200-megahertz signal (channel isolation at least 50:1 at 200 megahertz).

j. Move the amplifier unit to the RIGHT VERT compartment (leave signal connected).

k. Set the generator for an eight-division display at 200 megahertz.

l. Set the VERTICAL MODE switch to LEFT.

✓m. CHECK—CRT display for not more than 0.2 division of 200-megahertz signal (channel isolation at least 50:1 at 200 megahertz).

n. Set the VERTICAL MODE switch to RIGHT.

o. Set the generator for an eight-division display at 100 megahertz.

p. Set the VERTICAL MODE switch to LEFT.

✓q. CHECK—CRT display for not more than 0.1 division of 100-megahertz signal (channel isolation at least 100:1 at 100 megahertz).

r. Disconnect all test equipment.

✓18. Check Vertical Display Modes

a. Install another amplifier unit or the signal standardizer calibration fixture in the LEFT VERT compartment.

b. Position the trace to the upper half of the graticule area with the left-vertical unit position control.

c. Set the VERTICAL MODE switch to RIGHT and position the trace to the lower half of the graticule area with the right-vertical unit position control.

✓d. CHECK—CRT display for two traces in the ALT and CHOP positions of the VERTICAL MODE switch.

e. Set the VERTICAL MODE switch to ADD.

✓f. CHECK—CRT display for a single trace that can be positioned vertically with either vertical-unit position control.

✓19. Check Vertical Trace Separation Operation

a. Set the VERTICAL MODE switch to RIGHT.

b. Center the trace vertically with the right-vertical unit position control.

c. Install another time-base unit in the B HORIZ compartment.

d. Set both time-base units for a free-running sweep at a rate of 0.2 millisecond/division.

e. Set the HORIZONTAL MODE switch to CHOP.

✓f. CHECK—Turn the VERT TRACE SEPARATION (B) control throughout its range and check that the trace produced by the B time-base unit can be positioned above and below the trace produced by the A time-base unit. Also, check with the HORIZONTAL MODE switch set to ALT.

g. Remove all plug-in units.

TRIGGER SYSTEM CALIBRATION

Equipment Required

- | | |
|--|-----------------------------------|
| 1. Signal standardizer calibration fixture | 5. Test-oscilloscope (dual trace) |
| 2. 7B92 time-base plug-in unit | 6. Two 42-inch 50-ohm BNC cables |
| 3. 7A19 vertical amplifier plug-in unit | 7. Two 50-ohm terminations |
| 4. Plug-in extender calibration fixture | 8. Seven-inch screwdriver |

Control Settings

Set the 7704A controls as follows:

POWER	ON
VERTICAL MODE	RIGHT
VERT TRACE	
SEPARATION (B)	Midrange
A TRIGGER SOURCE	VERT MODE
A INTEN	Midrange
HORIZONTAL MODE	A
B INTEN	Midrange
B TRIGGER SOURCE	VERT MODE
INTENSITY	Midrange
FOCUS	Set for a well-defined display
READOUT	OFF
GRAT ILLUM	Midrange

√20. Check Trigger Selector Operation

- a. Remove all plug-in units. Install the plug-in extender fixture in the horizontal compartment.
- b. Connect the trigger lines from the plug-in extender (A20 and B20) to the test-oscilloscope. Use one 50-ohm BNC cable and 50-ohm termination from each trigger line to the test-oscilloscope vertical channels.
- c. Set both test-oscilloscope vertical channels for a deflection factor 50 millivolts/division ground input coupling. Set the test oscilloscope for differential operation between the two channels (added display mode with one channel inverted) at a sweep rate of 20 microseconds/division. Set input coupling to DC.
- d. CHECK—The test-oscilloscope display for a DC level within 0.5 division (25 millivolts) of the ground reference level in the LEFT, RIGHT, and ADD positions of the VERT MODE switch.

e. Install the signal standardizer calibration fixture in the left vertical compartment. Set the signal standardizer calibration fixture to triggering gain.

f. Set the VERT MODE switch to LEFT.

g. CHECK—Test-oscilloscope display for nine traces with the deflection between the second and eighth traces of six divisions ± 0.9 division (300 millivolts within 45 millivolts). Install the signal standardizer calibration fixture in the right vertical compartment. Set the VERT MODE switch to RIGHT.

h. CHECK—Trigger gain of the right vertical compartment.

√21A. CHECK Trigger Selector Operation

- a. Install the time-base plug-in unit in the horizontal compartment and the vertical amplifier plug-in unit in the left vertical compartment.
- b. Set the left vertical amplifier plug-in unit for a deflection factor of 0.2 volt/division.
- c. Connect the 0.4 calibrator signal to input connector of the left vertical amplifier plug-in unit.
- d. Set the signal standardizer calibration fixture test switch to Vert or Horiz +Step Resp, and the Rep Rate switch to 1 kHz. Set the amplitude control for a two-division display.

e. Set the VERT MODE switch to ALT position, the left vertical display to bottom half of the graticule. Position the right vertical display to the upper half of the graticule.

f. Set the time-base plug-in unit for a sweep rate of 0.2 millisecond/division.

√g. CHECK—That both displays are triggered (stable display).

√h. CHECK—Press, in sequence, the VERT MODE switch push buttons. Check that a stable display is obtained in all switch positions. In the CHOP MODE a triggered display of the left or right Vertical should be obtained (depending on the position of the Level/Slope control of the time-base unit).

i. Press the LEFT TRIG SOURCE button.

√j. CHECK—Press, in sequence, the VERT MODE switch push buttons. Check that only the LEFT vertical display is triggered.

k. Press the RIGHT TRIG SOURCE button.

√l. CHECK—Press, in sequence, the VERT MODE switch push buttons. Check that only the right vertical display is triggered.

m. Disconnect all test equipment and remove the plug-in units.

HORIZONTAL SYSTEM

Equipment Required

- | | |
|---|--|
| 1. Signal standardizer calibration fixture
2. Time-base plug-in unit (two required)
3. Amplifier plug-in unit
4. Time-mark generator | 5. Low-frequency signal generator
6. Three-inch screwdriver
7. Low-capacitance screwdriver |
|---|--|

NOTE

The location of adjustments is shown on pullout page 6-35, in the Diagrams section.

Control Settings

Set the 7704A controls as follows:

POWER	ON
VERTICAL MODE	RIGHT
VERT TRACE SEPARATION (B)	Midrange
A TRIGGER SOURCE	VERT MODE
A INTEN	Midrange
HORIZONTAL MODE	B
B INTEN	Midrange
B TRIGGER SOURCE	VERT MODE
INTENSITY	Midrange
FOCUS	Set for a well-defined display
GRAT ILLUM	Midrange

NOTE

The Horizontal Interface Gain adjustments do not need to be checked during routine calibration. However, if components are replaced or if the Acquisition Unit is used in a different system, adjustment might be necessary. The need for adjustment is indicated if the Horizontal System adjustments can not be performed according to the following procedure. Calibration information for the Horizontal Interface is given under Special Adjustment Procedures in the Maintenance section.

√21B. Adjust Horizontal Amplifier Gain

- a. Install a time-base unit in the RIGHT VERT compartment.

- b. Set the time-base unit for a free-running sweep at a rate of 0.1 millisecond/division.

c. Install the signal standardizer calibration fixture in the B HORIZ compartment.

d. Set the calibration fixture Test switch to Vert or Horiz Gain and the Rep Rate switch to 100 kHz.

e. Position the display to align the bright center trace with the center vertical line of the graticule.

√f. CHECK—Deflection between the second and tenth traces is eight divisions ± 0.08 division. Note the exact deflection for step 21j.

g. ADJUST—Horizontal Gain adjustment R4310 (see Fig. 6-34) for eight divisions of deflection between the second and tenth traces.

h. Move the calibration fixture to the A HORIZ compartment.

i. Set the HORIZONTAL MODE switch to A.

√j. CHECK—Deflection between the second and tenth traces is the same as in part f $\pm 1\%$ (eight divisions ± 0.08 division, if R4310 was adjusted in part g).

k. ADJUST—If necessary, compromise the setting of R4310 for optimum gain for both horizontal compartments. If re-adjustment is necessary, recheck parts c through j.

22. Adjust Horizontal Amplifier Centering

a. Set the calibration fixture Test switch to Triggering Gain.

b. CHECK—Vertical trace should align with the vertical center line of the graticule within 0.2 division. Check also with the HORIZONTAL MODE switch in the CHOP position.

c. ADJUST—Horizontal Centering adjustment R4325 (see Fig. 6-34) to position the trace to the vertical center line. If necessary, adjust for best compromise in the A and CHOP positions of the HORIZONTAL MODE switch.

d. INTERACTION—If R4325 is adjusted, check step 21.

23. Adjust Horizontal Amplifier Thermal Balance

a. Install a time-base unit in the B HORIZ compartment.

b. Set the HORIZONTAL MODE switch to CHOP and the VERTICAL MODE switch to LEFT.

c. Set the B time-base unit for a free-running, magnified sweep at a rate of 50 milliseconds/division.

d. CHECK—CRT display for not more than 0.1-division movement of the dot. If this instrument contains a readout system, set the READOUT intensity control for visible characters; check that the displayed characters do not move more than 0.1 division.

e. ADJUST—Thermal Balance adjustment R4346 (see Fig. 6-34) for minimum movement of the dot or readout characters.

f. INTERACTION—If the setting of R4346 is changed, check steps 21 and 22.

√ 24. Check Low-Frequency Linearity

a. Set the HORIZONTAL MODE switch to A and the VERTICAL MODE switch to RIGHT.

b. Set the calibration fixture Test switch to Vert or Horiz + Step Resp.

c. Set the calibration fixture Amplitude control for two divisions of deflection in the horizontal center of the graticule area.

√d. CHECK—Horizontally position the two-division display and check for not more than 0.1 division of compression or expansion anywhere within the graticule area.

√25. Adjust High-Frequency Timing

a. Install an amplifier unit in the LEFT VERT compartment.

b. Set the HORIZONTAL MODE switch to B and the VERTICAL MODE switch to LEFT.

c. Set the time-base unit for auto, internal triggering at a one-millisecond/division sweep rate.

d. Connect one-millisecond markers from the time-mark generator to the amplifier-unit input.

e. Position the first marker to the farthest left line of the graticule.

f. Set the time-base unit sweep-calibration adjustment for one marker at each major graticule division, between the second and tenth lines (center eight divisions).

√g. CHECK—Refer to the time-base unit instruction manual for performance check or calibration procedures for checking high-frequency timing and linearity. Use the procedures and limits given for the three fastest sweep rates which do not exceed two nanoseconds/division. If the given limits are met, omit the remainder of this step.

h. Set the VERTICAL MODE switch to RIGHT and the HORIZONTAL MODE switch to A.

i. Set the RIGHT VERT time-base unit for auto, external triggering at a magnified sweep rate of 0.5 microsecond/division (use basic sweep rate of five microseconds/division, magnified ten times with X10 magnifier or delayed sweep to 0.5 microsecond/division).

j. Connect the calibration-fixture Trig Out connector to the external trigger input of the RIGHT VERT time-base unit.

Calibration—7704A Service

k. Set the calibration fixture for an eight-division display with the Rep Rate switch set to 100 kHz. Horizontally center the display.

l. ADJUST—Horizontal Amplifier high-frequency compensation adjustments R4385, C4385, C4391, and C4374 (see Fig. 6-34) for optimum square-wave response. Check the leading edge of the pulse (lower right corner) for aberrations not to exceed +1.2 division with total peak-to-peak aberrations not to exceed 1.2 division. See Fig. 4-1 for a typical response waveform.

m. Repeat parts b through g of this step.

n. Disconnect all test equipment and remove the plug-in units.

✓ 26. Check X-Y Phase Shift

a. Install identical-type amplifier units in the RIGHT VERT and A HORIZ compartments.

b. Set both amplifier units for a deflection factor of ten millivolts/division with DC input coupling.

c. Connect the low-frequency signal generator to both amplifier units.

d. Set the signal generator for eight divisions of vertical and horizontal deflection at an output frequency of 50 kilohertz.

✓e. CHECK—CRT lissajous display for an opening at the center vertical line of 0.28 division or less (indicates 2° or less phase shift; see Fig. 4-2).

f. Move the A HORIZ unit to the B HORIZ compartment and set the HORIZONTAL MODE switch to B (leave signal connected).

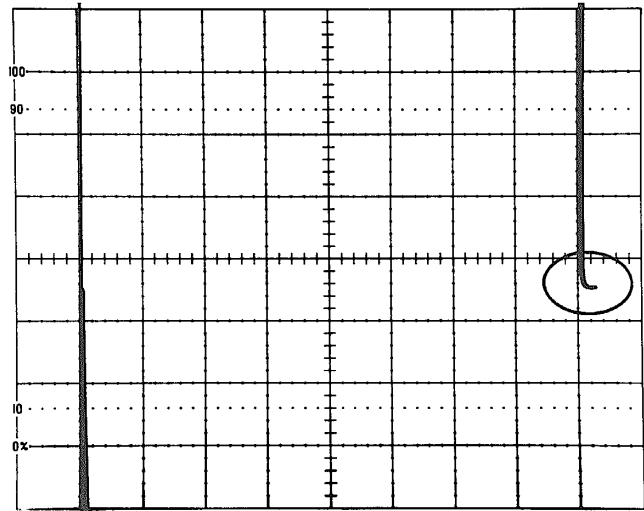

Fig. 4-1. Waveform showing correct high-frequency compensation of horizontal amplifier. Circle surrounds compensated portion of waveform.

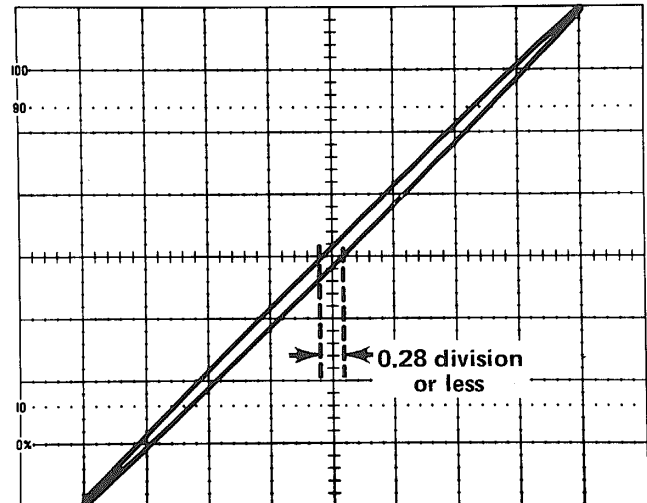

Fig. 4-2. Typical display when checking X-Y phase shift.

✓g. Repeat parts d and e.

h. Disconnect all test equipment and remove the plug-in units.

CALIBRATOR

Equipment Required

- | | |
|--|---------------------------|
| 1. Precision DC voltmeter | 4. Time-mark generator |
| 2. Amplifier plug-in unit (two required) | 5. Three-inch screwdriver |
| 3. Time-base plug-in unit | |

NOTE

The location of adjustments and test points for calibration is shown on a pullout, page 6-35, in the Diagrams section.

Control Settings

Set the 7704A controls as follows:

POWER	ON
VERTICAL MODE	RIGHT
VERT TRACE SEPARATION (B)	Midrange
A TRIGGER SOURCE	VERT MODE
A INTEN	Midrange
HORIZONTAL MODE	A
B INTEN	Midrange
B TRIGGER SOURCE	VERT MODE
INTENSITY	Midrange
FOCUS	Set for a well-defined display
READOUT	OFF
GRAT ILLUM	Midrange

✓27. Adjust Calibrator Output Voltage

a. Connect the inner lead of C1001 to chassis ground. (C1001 is the large, metal-cased capacitor located on the Calibrator Board behind the HORIZONTAL MODE switch circuit board; see Fig. 6-35.

b. Connect the precision DC voltmeter between the CALIBRATOR 0.4 V and GND pin jacks.

✓c. CHECK—Meter reading; 0.4 volt ± 0.004 volt within 0.008 volt if this measurement is made outside the $+15^{\circ}\text{C}$ to $+35^{\circ}\text{C}$ temperature range).

NOTE

If a zero-volt meter reading is obtained, momentarily remove the connection between C1001 and ground for a DC output.

d. ADJUST—0.4 V adjustment R1037 (see Fig. 6-35) for a meter reading of exactly 0.4 volt.

e. Disconnect the precision DC voltmeter and the connection between C1001 and ground.

✓28. Adjust Calibrator 1 kHz Repetition Rate

NOTE

If a frequency counter with an accuracy of at least 0.1% is available (such as Tektronix 7D14 Digital Counter), it can be used to adjust the Calibrator repetition rate.

a. Install an amplifier unit in both vertical compartments and a time-base unit in the A HORIZ compartment.

b. Set the VERTICAL MODE switch to ALT.

c. Connect the 0.4 V CALIBRATOR pin jack to the input of one of the amplifier units.

d. Connect one-millisecond markers from the time-mark generator to the other amplifier unit.

e. Set the amplifier units for a marker display of about two divisions and a square-wave display of about four divisions.

f. Set the time-base unit for a stable display of both waveforms in the normal, internal trigger mode at a 0.2-millisecond/division sweep rate.

Calibration—7704A Service

g. Vertically position the displays so the tips of the markers fall just below the bottom of the square wave.

h. Set the VERTICAL MODE switch to ADD.

i. Set the time-base unit triggering so a stable square-wave display is presented only when the markers occur during the positive portion of the square wave.

j. Set the time-base unit triggering for AC low-frequency reject coupling, and a sweep rate of 0.2 second/division.

√k. CHECK—The amount of time required for a time mark to drift across the positive level of the square wave, to the negative level and back to the positive level, must not

exceed 0.4 second (0.2 second if outside the +15°C to +35°C temperature range). This time can be measured directly from the display by observing the number of divisions that the marker moves across the display area before it returns to the positive level.

l. ADJUST—1 kHz adjustment R1001 (see Fig. 6-35) for a time not to exceed 0.4 second for a time mark to drift across the positive level of the square wave to the negative level and back to the positive level. (A preliminary adjustment can be made with the time-base unit triggered only on the squarewave at a 0.2-millisecond/division sweep rate; adjust R1001 for minimum drift of the markers.)

m. Disconnect all test equipment and remove the plug-in units.

OUTPUT SIGNALS

NOTE

If the Signal Buffer sub-assembly is deleted from this instrument (Option 7), delete this portion of the Calibration procedure.

Equipment Required

- | | |
|--|--|
| 1. Amplifier plug-in unit (two required) | 2. Time-base plug-in unit (two required) |
|--|--|

NOTE

The location of the signal selector switches is shown on a pullout, page 6-35, in the Diagrams section.

Control Settings

Set the controls as follows:

POWER	ON
VERTICAL MODE	RIGHT
VERT TRACE SEPARATION (B)	Midrange
A TRIGGER SOURCE	VERT MODE
A INTEN	Midrange
HORIZONTAL MODE	A
B INTEN	Midrange
B TRIGGER SOURCE	VERT MODE
INTENSITY	Midrange
FOCUS	Set for a well-defined display
READOUT	OFF
GRAT ILLUM	Midrange

f. Set the Sweep Selector switch, S3320, to B. (S3320 is located behind the right side panel, near the rear of the instrument; see Fig. 6-36.)

√g. CHECK—CRT display for sawtooth waveform with an amplitude of five divisions ± 75 div (output amplitude into 50-ohm load, 0.5 volt or greater).

h. Set the HORIZONTAL MODE switch to B.

i. Set the Sweep Selector switch to A.

j. Set the B HORIZ time-base unit for auto, internal triggering at a sweep rate of two milliseconds/division.

k. Set the A HORIZ time-base unit for a free-running sweep at a rate of 0.5 millisecond/division.

√29. Check Sawtooth Output Signals

a. Install amplifier units in both vertical compartments and time-base units in both horizontal compartments.

b. Connect the rear-panel + SAWTOOTH OUT connector to the RIGHT VERT amplifier unit.

c. Set the RIGHT VERT amplifier unit for a calibrated deflection factor of 0.1 volt/division with DC input coupling.

d. Set the A HORIZ time-base unit for auto, internal triggering at a sweep rate of two milliseconds/division.

e. Set the B HORIZ time-base unit for a free-running sweep at a rate of 0.5 millisecond/division.

√l. CHECK—CRT display for a sawtooth waveform with an amplitude of five divisions ± 75 div (output amplitude into 50-ohm load, 0.5 volt or greater).

m. Disconnect the + SAWTOOTH OUT connector from the amplifier unit.

√30. Check Gate Output Signals

a. Connect the rear-panel + GATE OUT connector to the RIGHT VERT amplifier unit.

b. Set the RIGHT VERT amplifier unit for a calibrated deflection factor of 100 millivolts/division with DC input coupling.

Calibration—7704A Service

c. Set the Gate Selector switch, S3340, to A. (S3340 is located behind the right side panel, near the rear of the instrument; see Fig. 6-36.)

√d. CHECK—CRT display for gate waveform five divisions ± 0.5 division in amplitude (output amplitude into 50-ohm load, 0.5 volt $\pm 10\%$).

e. Set the HORIZONTAL MODE switch to A.

f. Set the Gate Selector switch to B.

g. Set the A HORIZ time-base unit for auto, internal triggering at a sweep rate of two milliseconds/division.

h. Set the B HORIZ time-base unit for a free-running sweep at a rate of 500 microseconds/division.

√i. CHECK—CRT display for gate waveform five divisions ± 0.5 division in amplitude (output amplitude into 50-ohm load, 0.5 volt $\pm 10\%$).

j. Set the A HORIZ time-base unit for a 10-nanosecond/division sweep rate. Set the triggering to display the rising portion of the waveform. Set B Horiz to 100 nanosecond/division.

√k. CHECK—Displayed waveform for not more than two divisions between the 10% and 90% points (risetime, twenty nanoseconds or less).

l. Disconnect the + GATE OUT connector from the amplifier unit.

√31. Check Vertical Signal Output

a. Connect the CALIBRATOR 0.4 V pin jack to the RIGHT VERT amplifier unit.

b. Set the A HORIZ time-base unit for auto, internal triggering at a sweep rate of 500 microseconds/division.

c. Set the RIGHT VERT amplifier unit for a four-division display.

d. Connect the rear-panel VERT SIG OUT connector to the LEFT VERT amplifier unit.

e. Set the LEFT VERT amplifier unit for a calibrated deflection factor of 20 millivolts/division with DC input coupling (10 millivolts/division with option 4 CRT).

f. Set the B TRIGGER SOURCE switch to RIGHT VERT and the VERTICAL MODE switch to LEFT.

√g. CHECK—CRT Display for waveform five divisions (2.5 divisions with Option 4 CRT) ± 0.5 division in amplitude (voltage output into 50-ohm load, 25 millivolts/division of display within 10%).

h. Disconnect all test equipment and remove the plug-in units.

READOUT SYSTEM

NOTE

If the Readout System was deleted from the instrument being calibrated (Option 1), omit this section of the procedure.

Equipment Required

- | | |
|--|---------------------------|
| 1. Amplifier plug-in unit (dual trace) | 3. Three-inch screwdriver |
| 2. Time-base plug-in unit | |

NOTE

The location of adjustments for calibration is shown on a pullout, page 6-35, in the Diagrams section.

Control Settings

Set the 7704A controls as follows:

POWER	OFF
VERTICAL MODE	RIGHT
VERT TRACE	
SEPARATION (B)	Midrange
A TRIGGER SOURCE	VERT MODE
A INTEN	Midrange
HORIZONTAL MODE	A
B INTEN	Midrange
B TRIGGER SOURCE	VERT MODE
INTENSITY	Midrange
FOCUS	Set for a well-defined display
READOUT	OFF
GRAT ILLUM	Midrange

NOTE

These tolerances are provided as guides to correct instrument operation and are not instrument specifications.

- e. ADJUST—Vertical Separation adjustment R4390 (see Fig. 6-37) to position the two rows of readout characters to the middle of the top and bottom divisions of the graticule.

NOTE

The Vertical Amplifier Centering adjustment must be correct before making this adjustment; see step 11.

- f. Set the POWER switch to off and replace Q3416 (see Fig. 6-37) in its socket; return the POWER switch to on.

32. Adjust Vertical Separation

- Remove Q3416 from its socket on A34, Readout Board (see Fig. 6-37).
- Set the POWER switch to on.
- Set the READOUT control for visible characters (all zeros).
- CHECK—CRT display for two rows of zeros, 40 zeros to a row with no overlap. The two rows of zeros should be located vertically in the middle of the top and bottom divisions of the graticule (see Fig. 4-3).

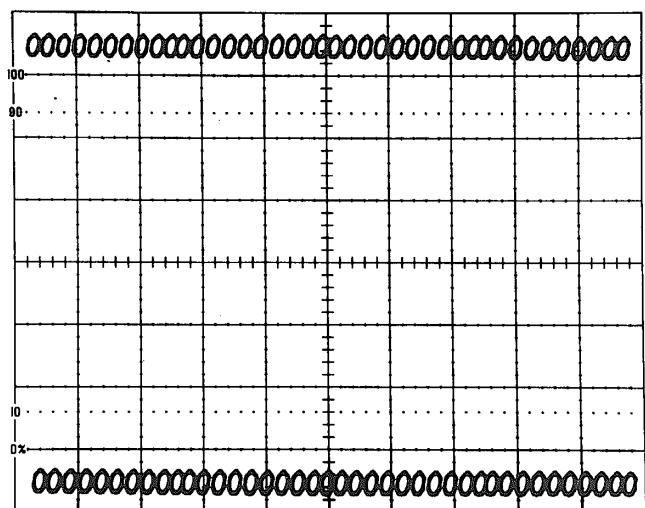

Fig. 4-3. Readout display with Q3416 removed.

33. Adjust Full Character Scan

- a. Install the dual-trace amplifier unit in the RIGHT VERT compartment.
- b. Set the amplifier unit for a deflection factor of 50 millivolts/division.
- c. CHECK—Displayed characters for completeness without overscanning (overscanning causes a bright dot where traces overlap).
- d. ADJUST—Full Character Scan adjustment R3437 (see Fig. 6-37) for fully scanned characters without overscanning. The m and the 5 will show the most change.

34. Adjust Column and Row Match

- a. Set the amplifier unit for a dual-trace display mode.
- b. Press and hold the amplifier unit trace-identify buttons.
- c. CHECK—Readout display for correct indication of "IDENTIFY". If the readout display blinks or is incorrect, adjustment is required.
- d. ADJUST—Column Match adjustment R3407 (see Fig. 6-37) for correct readout of "IDENTIFY". Set this adjustment to the center of the adjustment range which provides correct readout indication. Center Row Match adjustment R3422. Release the amplifier unit trace-identify buttons.

✓ 35. Check Readout Modes

NOTE

If the Signal Buffer sub-assembly is deleted from the instrument being calibrated (Option 7), omit this step.

- a. Install a time-base unit in the A HORIZ compartment.
 - b. Set the time-base unit for a free-running sweep.
 - c. Set the Readout Mode switch to FR and the Gate Selector switch to A (see Fig. 6-36).
 - ✓d. CHECK—Set the time-base unit for several sweep rates throughout its range. Check that the readout characters are presented on a free-run basis, independent of the sweep rate.
 - e. Set the Readout Mode switch to Gated (see Fig. 6-36).
 - f. Set the time-base unit for a free-running sweep at a rate of 0.1 second/division.
 - ✓g. CHECK—Readout characters are blanked out while the sweep is running, and are displayed immediately after the end of the sweep; each character encoded by the plug-in units is displayed only once for each sweep.
- This completes the Calibration procedure for the 7704A. Disconnect all test equipment and replace the side panels.

REPLACEABLE ELECTRICAL PARTS

PARTS ORDERING INFORMATION

Replacement parts are available from or through your local Tektronix, Inc. Field Office or representative.

Changes to Tektronix instruments are sometimes made to accommodate improved components as they become available, and to give you the benefit of the latest circuit improvements developed in our engineering department. It is therefore important, when ordering parts, to include the following information in your order: Part number, instrument type or number, serial number, and modification number if applicable.

If a part you have ordered has been replaced with a new or improved part, your local Tektronix, Inc. Field Office or representative will contact you concerning any change in part number.

Change information, if any, is located at the rear of this manual.

SPECIAL NOTES AND SYMBOLS

X000 Part first added at this serial number

00X Part removed after this serial number

ITEM NAME

In the Parts List, an Item Name is separated from the description by a colon (:). Because of space limitations, an Item Name may sometimes appear as incomplete. For further Item Name identification, the U.S. Federal Cataloging Handbook H6-1 can be utilized where possible.

ABBREVIATIONS

ACTR	ACTUATOR	PLSTC	PLASTIC
ASSY	ASSEMBLY	QTZ	QUARTZ
CAP	CAPACITOR	RECP	RECEPTACLE
CER	CERAMIC	RES	RESISTOR
CKT	CIRCUIT	RF	RADIO FREQUENCY
COMP	COMPOSITION	SEL	SELECTED
CONN	CONNECTOR	SEMICOND	SEMICONDUCTOR
ELCTLT	ELECTROLYTIC	SENS	SENSITIVE
ELEC	ELECTRICAL	VAR	VARIABLE
INCAND	INCANDESCENT	WW	WIREWOUND
LED	LIGHT EMITTING DIODE	XFMR	TRANSFORMER
NONWIR	NON WIREWOUND	XTAL	CRYSTAL

CROSS INDEX—MFR. CODE NUMBER TO MANUFACTURER

Mfr. Code	Manufacturer	Address	City, State, Zip
0000A	LEMO USA	2015 2ND STREET	BERKLEY, CA 94710
0000W	UNITED CHEMICON, INC.	731 JAMES STREET	SYRACUSE, NY 13203
00853	SANGAMO ELECTRIC CO., S. CAROLINA DIV.	P O BOX 128	PICKENS, SC 29671
01121	ALLEN-BRADLEY COMPANY	1201 2ND STREET SOUTH	MILWAUKEE, WI 53204
01295	TEXAS INSTRUMENTS, INC., SEMICONDUCTOR GROUP	P O BOX 5012, 13500 N CENTRAL EXPRESSWAY	DALLAS, TX 75222
02735	RCA CORPORATION, SOLID STATE DIVISION	ROUTE 202	SOMERVILLE, NY 08876
02777	HOPKINS ENGINEERING COMPANY	12900 FOOTHILL BLVD.	SAN FERNANDO, CA 91342
04222	AVX CERAMICS, DIVISION OF AVX CORP.	P O BOX 867, 19TH AVE. SOUTH	MURTL BEACH, SC 29577
04713	MOTOROLA, INC., SEMICONDUCTOR PROD. DIV.	5005 E MCDOWELL RD, PO BOX 20923	PHOENIX, AZ 85036
05091	TRI-ORDINATE CORPORATION	343 SNYDER AVENUE	BERKELEY HEIGHTS, NJ 07922
05397	UNION CARBIDE CORPORATION, MATERIALS SYSTEMS DIVISION	11901 MADISON AVENUE	CLEVELAND, OH 44101
07910	TELEDYNE SEMICONDUCTOR	12515 CHADRON AVE.	HAWTHORNE, CA 90250
08806	GENERAL ELECTRIC CO., MINIATURE LAMP PRODUCTS DEPARTMENT	NELA PARK	CLEVELAND, OH 44112
11237	CTS KEENE, INC.	3230 RIVERSIDE AVE.	PASO ROBLES, CA 93446
12697	CLAROSTAT MFG. CO., INC.	LOWER WASHINGTON STREET	DOVER, NH 03820
12969	UNITRODE CORPORATION	580 PLEASANT STREET	WATERTOWN, MA 02172
15454	RODAN INDUSTRIES, INC.	2905 BLUE STAR ST.	ANAHEIM, CA 92806
32997	BOURNS, INC., TRIMPOT PRODUCTS DIV.	1200 COLUMBIA AVE.	RIVERSIDE, CA 92507
34553	AMPEREX ELECTRONIC CORP., COMPONENT DIV.	35 HOFFMAN AVE.	HAPPAUGE, NY 11787
50157	N. L. INDUSTRIES, INC., ELECTRONICS DEPT.	P. O. BOX 787	MUSKEGON, MI 49445
53944	ELT INC., GLOW LITE DIVISION	BOX 698	PAULS VALLEY, OK 73075
55210	GETTIG ENG. AND MFG. COMPANY	PO BOX 85, OFF ROUTE 45	SPRING MILLS, PA 16875
56289	SPRAGUE ELECTRIC CO.		NORTH ADAMS, MA 01247
63743	WARD LEONARD ELECTRIC CO., INC.	31 SOUTH ST.	MOUNT VERNON, NY 10550
71400	BUSSMAN MFG., DIVISION OF MCGRAW-EDISON CO.	2536 W. UNIVERSITY ST.	ST. LOUIS, MO 63107
71590	CENTRALAB ELECTRONICS, DIV. OF GLOBE-UNION, INC.	P O BOX 858	FORT DODGE, IA 50501
72982	ERIE TECHNOLOGICAL PRODUCTS, INC.	644 W. 12TH ST.	ERIE, PA 16512
73138	BECKMAN INSTRUMENTS, INC., HELIPOT DIV.	2500 HARBOR BLVD.	FULLERTON, CA 92634
73899	JFD ELECTRONICS COMPONENTS CORP.	PINETREE ROAD	OXFORD, NC 27565
75042	TRW ELECTRONIC COMPONENTS, IRC FIXED RESISTORS, PHILADELPHIA DIVISION	401 N. BROAD ST.	PHILADELPHIA, PA 19108
78488	STACKPOLE CARBON CO.		ST. MARYS, PA 15857
79727	C-W INDUSTRIES	550 DAVISVILLE RD., P O BOX 96	WARMINSTER, PA 18974
80009	TEKTRONIX, INC.	P O BOX 500	BEAVERTON, OR 97077
80740	BECKMAN INSTRUMENTS, INC.	2500 HARBOR BLVD.	FULLERTON, CA 92634
81483	INTERNATIONAL RECTIFIER CORP.	9220 SUNSET BLVD.	LOS ANGELES, CA 90069
82389	SWITCHCRAFT, INC.	5555 N. ELSTON AVE.	CHICAGO, IL 60630
84411	TRW ELECTRONIC COMPONENTS, TRW CAPACITORS	112 W. FIRST ST.	OGALLALA, NE 69153
90201	MALLORY CAPACITOR CO., DIV. OF P. R. MALLORY AND CO., INC.	3029 E WASHINGTON STREET	INDIANAPOLIS, IN 46206
		P O BOX 372	COLUMBUS, NE 68601
91637	DALE ELECTRONICS, INC.	P. O. BOX 609	FREEMONT, IL 61032
91929	HONEYWELL, INC., MICRO SWITCH DIV.	CHICAGO & SPRING STS.	WOODSIDE, NY 11377
95238	CONTINENTAL CONNECTOR CORP.	34-63 56TH ST.	

Ckt No.	Tektronix Part No.	Serial/Model No. Eff	Dscont	Name & Description	Mfr Code	Mfr Part Number
A10	670-1879-00			CKT BOARD ASSY:CABLBRATION	80009	670-1879-00
A11	670-1877-00			CKT BOARD ASSY:VERTICAL MODE SWITCH	80009	670-1877-00
A12	670-1878-00			CKT BOARD ASSY:HORIZONTAL MODE SWITCH	80009	670-1878-00
A13	670-1876-00			CKT BOARD ASSY:A TRIGGER SOURCE SWITCH	80009	670-1876-00
A14	670-1876-00			CKT BOARD ASSY:B TRIGGER SOURCE SWITCH	80009	670-1876-00
A20	670-1880-00			CKT BOARD ASSY:MAIN INTERFACE	80009	670-1880-00
A22	670-1881-00			CKT BOARD ASSY:VERTICAL INTERFACE	80009	670-1881-00
A23	670-1883-00			CKT BOARD ASSY:HORIZONTAL INTERFACE	80009	670-1883-00
A24	670-1882-00			CKT BOARD ASSY:TRIGGER SELECTOR	80009	670-1882-00
A25	670-1884-00	B010100	B109999	CKT BOARD ASSY:LOGIC	80009	670-1884-00
A25	670-1884-01	B110000	B132604	CKT BOARD ASSY:LOGIC	80009	670-1884-01
A25	670-1884-02	B132605	B194311	CKT BOARD ASSY:LOGIC	80009	670-1884-02
A25	670-1884-03	B194312		CKT BOARD ASSY:LOGIC	80009	670-1884-03
A30	670-1985-00	B010100	B099999	CKT BOARD ASSY:LINE INVERTER	80009	670-1985-00
A30	670-1985-02	B100000		CKT BOARD ASSY:LINE INVERTER	80009	670-1985-02
A31	670-1887-00	B010100	B079999	CKT BOARD ASSY:RECTIFIER	80009	670-1887-00
A31	670-1887-01	B080000	B209999	CKT BOARD ASSY:RECTIFIER	80009	670-1887-01
A31	670-1887-02	B210000		CKT BOARD ASSY:RECTIFIER	80009	670-1887-02
A32	670-1888-00	B010100	B099999	CKT BOARD ASSY:LV REGULATOR	80009	670-1888-00
A32	670-1888-01	B100000		CKT BOARD ASSY:LV REGULATOR	80009	670-1888-01
A33	670-1886-00			CKT BOARD ASSY:SIGNAL OUT	80009	670-1886-00
A34	670-1885-00	B010100	B049999	CKT BOARD ASSY:READOUT	80009	670-1885-00
A34	670-1885-02	B050000		CKT BOARD ASSY:READOUT	80009	670-1885-02
A41	670-1854-00	B010100	B199999	CKT BOARD ASSY:Z AXIS	80009	670-1854-00
A41	670-1854-01	B200000		CKT BOARD ASSY:Z AXIS	80009	670-1854-01
A42	670-1855-00	B010100	B039999	CKT BOARD ASSY:HIGH VOLTAGE	80009	670-1855-00
A42	670-1855-01	B040000		CKT BOARD ASSY:HIGH VOLTAGE	80009	670-1855-01
A43	670-1853-00	B010100	B109999	CKT BOARD ASSY:HORIZONTAL AMPLIFIER	80009	670-1853-00
A43	670-1853-01	B110000		CKT BOARD ASSY:HORIZONTAL AMPLIFIER	80009	670-1853-01
A44	670-1852-00	B010100	B119999	CKT BOARD ASSY:VERTICAL AMPLIFIER	80009	670-1852-00
A44	670-1852-01	B120000	B139999	CKT BOARD ASSY:VERTICAL AMPLIFIER	80009	670-1852-01
A44	670-1852-02	B140000		CKT BOARD ASSY:VERTICAL AMPLIFIER	80009	670-1852-02
A50	670-0702-00			CKT BOARD ASSY:GRATICULE LIGHTS	80009	670-0702-00
A51	670-4347-00	XB160000		CKT BOARD ASSY:PROTECTION	80009	670-4347-00
C1001	285-0756-01			CAP.,FXD,PLASTC:0.05UF,0.25%,400V	80009	285-0756-01
C1004	283-0000-00			CAP.,FXD,CER DI:0.001UF,+100-0%,500V	72982	831-516E102P
C1011	283-0003-00			CAP.,FXD,CER DI:0.01UF,+80-20%,150V	72982	855-558Z5U-103Z
C1031	283-0003-00			CAP.,FXD,CER DI:0.01UF,+80-20%,150V	72982	855-558Z5U-103Z
C2006	283-0000-00			CAP.,FXD,CER DI:0.001UF,+100-0%,500V	72982	831-516E102P
C2081	290-0519-00			CAP.,FXD,ELCTLT:100UF,20%,20V	90201	TDC107M020WLD
C2083	290-0531-00			CAP.,FXD,ELCTLT:100UF,20%,10V	90201	TDC107M010WLC
C2085	290-0519-00			CAP.,FXD,ELCTLT:100UF,20%,20V	90201	TDC107M020WLD
C2087	290-0270-00	B010100	B142899	CAP.,FXD,ELCTLT:8.2UF,20%,60V	56289	150D825X0060R2
C2087	290-0716-00	B142900		CAP.,FXD,ELCTLT:8.2UF,20%,75V	05397	T11C825M075AS
C2089	290-0270-00	B010100	B142899	CAP.,FXD,ELCTLT:8.2UF,20%,60V	56289	150D825X0060R2
C2089	290-0716-00	B142900		CAP.,FXD,ELCTLT:8.2UF,20%,75V	05397	T11C825M075AS
C2201	281-0580-00	XB194145		CAP.,FXD,CER DI:470PF,10%,500V	04222	7001-1374
C2231	281-0151-00	B010100	B079999	CAP.,VAR,CER DI:1-3PF,100V	72982	518-600A1-3
C2231	281-0184-00	B080000		CAP.,VAR,PLSTC:2-18PF,500VDC	34553	2222-809-05003
C2235	281-0509-00	B010100	B079999	CAP.,FXD,CER DI:15PF,+/-1.5PF,500V	72982	301-000C0G0150K
C2235	281-0609-00	B080000		CAP.,FXD,CER DI:1PF,+/-0.1PF,500V	72982	374-005C0K0109B
C2259	281-0547-00	XB050000		CAP.,FXD,CER DI:2.7PF,10%,500V	72982	301-000C0J0279C
C2267	281-0547-00	XB050000		CAP.,FXD,CER DI:2.7PF,10%,500V	72982	301-000C0J0279C

Replaceable Electrical Parts—7704A

Ckt No.	Tektronix Part No.	Serial/Model No. Eff	Dscont	Name & Description	Mfr Code	Mfr Part Number
C2277	281-0670-00			CAP.,FXD,CER DI:1.8PF,+/-0.1PF,500V	72982	374-005C0K0189B
C2279	281-0540-00			CAP.,FXD,CER DI:51PF,5%,500V	72982	301-000U2J0510J
C2281	281-0151-00	B010100	B079999	CAP.,VAR,CER DI:1-3PF,100V	72982	518-600A1-3
C2281	281-0184-00	B080000		CAP.,VAR,PLSTC:2-18PF,500VDC	34553	2222-809-05003
C2285	281-0509-00	B010100	B079999	CAP.,FXD,CER DI:15PF,+/-1.5PF,500V	72982	301-000C0G0150K
C2285	281-0609-00	B080000		CAP.,FXD,CER DI:1PF,+/-0.1PF,500V	72982	374-005C0K0109B
C2403	281-0534-00	XB080000		CAP.,FXD,CER DI:3.3PF,+/-0.25PF,500V	72982	301-000C0J0339C
C2406	281-0534-00	XB080000		CAP.,FXD,CER DI:3.3PF,+/-0.25PF,500V	72982	301-000C0J0339C
C2423	281-0653-00	XB040000	B079999	CAP.,FXD,CER DI:3.3PF,30%,200V	72982	374-001C0K0109C
C2423	281-0534-00	B080000		CAP.,FXD,CER DI:3.3PF,+/-0.25PF,500V	72982	301-000C0J0339C
C2427	281-0604-00	XB080000		CAP.,FXD,CER DI:2.2PF,+/-0.25PF,500V	72982	301-000C0J0229C
C2444	283-0000-00			CAP.,FXD,CER DI:0.001UF,+100-0%,500V	72982	831-516E102P
C2445	281-0601-00	B010100	B039999	CAP.,FXD,CER DI:7.5PF,500V	72982	301-000C0H0759D
C2445	281-0544-00	B040000	B163399	CAP.,FXD,CER DI:5.6PF,10%,500V	72982	301-000C0H0569D
C2445	281-0604-00	B163400		CAP.,FXD,CER DI:2.2PF,+/-0.25PF,500V	72982	301-000C0J0229C
C2448	283-0000-00			CAP.,FXD,CER DI:0.001UF,+100-0%,500V	72982	831-516E102P
C2510	283-0668-00			CAP.,FXD,MICA D:184PF,1%,500V	00853	D155F1840F0
C2511	283-0623-00			CAP.,FXD,MICA D:120PF,1%,100V	00853	D191F122F0
C2514	281-0564-00			CAP.,FXD,CER DI:24PF,5%,500V	72982	301-000C0G0240J
C2515	283-0003-00			CAP.,FXD,CER DI:0.01UF,+80-20%,150V	72982	855-558Z5U-103Z
C2518	281-0629-00	B010100	B079999X	CAP.,FXD,CER DI:33PF,5%,600V	72982	308-000C0G0330J
C2520	281-0525-00			CAP.,FXD,CER DI:470PF,+/-94PF,500V	04222	7001-1364
C2521	281-0525-00			CAP.,FXD,CER DI:470PF,+/-94PF,500V	04222	7001-1364
C2523	281-0543-00			CAP.,FXD,CER DI:270PF,10%,500V	72982	301055X5P271K
C2524	281-0629-00	XB120000		CAP.,FXD,CER DI:33PF,5%,600V	72982	308-000C0G0330J
C2529	281-0629-00	B010100	B079999X	CAP.,FXD,CER DI:33PF,5%,600V	72982	308-000C0G0330J
C2560	290-0534-00			CAP.,FXD,ELCTLT:1UF,20%,35V	56289	196D105X0035HA1
C2562	290-0512-00			CAP.,FXD,ELCTLT:22UF,20%,15V	56289	196D226X0015KA1
C2563	290-0534-00			CAP.,FXD,ELCTLT:1UF,20%,35V	56289	196D105X0035HA1
C2565	290-0534-00			CAP.,FXD,ELCTLT:1UF,20%,35V	56289	196D105X0035HA1
C2571	281-0589-00			CAP.,FXD,CER DI:170PF,5%,500V	72982	301000Z5D171J
C2572	281-0589-00			CAP.,FXD,CER DI:170PF,5%,500V	72982	301000Z5D171J
C2573	281-0603-00			CAP.,FXD,CER DI:39PF,5%,500V	72982	308-000C0G0390J
C2575	281-0603-00			CAP.,FXD,CER DI:39PF,5%,500V	72982	308-000C0G0390J
C2580	281-0523-00			CAP.,FXD,CER DI:100PF,+/-20PF,500V	72982	301-000U2M0101M
C2585	283-0000-00			CAP.,FXD,CER DI:0.001UF,+100-0%,500V	72982	831-516E102P
C2598	290-0534-00			CAP.,FXD,ELCTLT:1UF,20%,35V	56289	196D105X0035HA1
C3005	283-0006-00			CAP.,FXD,CER DI:0.02UF,+80-20%,500V	72982	0841545Z5V00203Z
C3006	283-0006-00			CAP.,FXD,CER DI:0.02UF,+80-20%,500V	72982	0841545Z5V00203Z
C3016	290-0576-00			CAP.,FXD,ELCTLT:550UF,+50-10%,200V	56289	36D7135
C3017	290-0576-00			CAP.,FXD,ELCTLT:550UF,+50-10%,200V	56289	36D7135
C3019	283-0057-00			CAP.,FXD,CER DI:0.1UF,+80-20%,200V	56289	274C10
C3027	283-0280-00			CAP.,FXD,CER DI:2200PF,10%,2000V	56289	29C558
C3028	283-0280-00	B010100	B020209X	CAP.,FXD,CER DI:2200PF,10%,2000V	56289	29C558
C3029	285-0939-00			CAP.,FXD,PLSTC:3UF,5%,400V	84411	TEK111-30594
C3030	283-0279-00			CAP.,FXD,CER DI:0.001UF,20%,3000V	56289	55C153
C3031	290-0395-00			CAP.,FXD,ELCTLT:4.7UF,20%,50V	56289	150D475X0050B2
C3035	283-0000-00	XB110000	B139999X	CAP.,FXD,CER DI:0.001UF,+100-0%,500V	72982	831-516E102P
C3035	283-0067-00	XB173850		CAP.,FXD,CER DI:0.001UF,10%,200V	72982	835-515B102K
C3037	285-0938-00			CAP.,FXD,PLSTC:0.03UF,5%,600V	56289	AF8B1G303J004
C3039	283-0280-00			CAP.,FXD,CER DI:2200PF,10%,2000V	56289	29C558
C3040	283-0000-00	B010100	B020209X	CAP.,FXD,CER DI:0.001UF,+100-0%,500V	72982	831-516E102P
C3042	290-0395-00			CAP.,FXD,ELCTLT:4.7UF,20%,50V	56289	150D475X0050B2

Replaceable Electrical Parts—7704A

Ckt No.	Tektronix Part No.	Serial/Model No. Eff	Discont	Name & Description	Mfr Code	Mfr Part Number
C3048	283-0001-00			CAP.,FXD,CER DI:0.005UF,+100-0%,500V	72982	831-559E502P
C3049	290-0159-00			CAP.,FXD,ELCTLT:2UF,+50-10%,150V	56289	30D205F150BB9
C3050	290-0164-00			CAP.,FXD,ELCTLT:1UF,+50-10%,150V	56289	30D105F150BA2
C3052	283-0003-00			CAP.,FXD,CER DI:0.01UF,+80-20%,150V	72982	855-558Z5U-103Z
C3105	283-0003-00			CAP.,FXD,CER DI:0.01UF,+80-20%,150V	72982	855-558Z5U-103Z
C3106	283-0003-00			CAP.,FXD,CER DI:0.01UF,+80-20%,150V	72982	855-558Z5U-103Z
C3108	290-0523-00			CAP.,FXD,ELCTLT:2.2UF,20%,20V	56289	196D225X0020HA1
C3113	283-0003-00			CAP.,FXD,CER DI:0.01UF,+80-20%,150V	72982	855-558Z5U-103Z
C3114	290-0524-00			CAP.,FXD,ELCTLT:4.7UF,20%,10V	90201	TDC475M010EL
C3117	290-0523-00			CAP.,FXD,ELCTLT:2.2UF,20%,20V	56289	196D225X0020HA1
C3125	281-0523-00			CAP.,FXD,CER DI:100PF,+/-20PF,500V	72982	301-000U2M0101M
C3126	281-0523-00			CAP.,FXD,CER DI:100PF,+/-20PF,500V	72982	301-000U2M0101M
C3127	290-0572-00			CAP.,FXD,ELCTLT:0.1UF,20%,50V	56289	196D104X0050HA1
C3129	290-0572-00			CAP.,FXD,ELCTLT:0.1UF,20%,50V	56289	196D104X0050HA1
C3134	283-0092-00			CAP.,FXD,CER DI:0.03UF,+80-20%,200V	72982	845-534E303Z
C3143	283-0028-00			CAP.,FXD,CER DI:0.0022UF,20%,50V	56289	19C606
C3150	283-0594-00			CAP.,FXD,MICA D:0.001UF,1%,100V	00853	D151F102FO
C3153	283-0003-00			CAP.,FXD,CER DI:0.01UF,+80-20%,150V	72982	855-558Z5U-103Z
C3154	283-0003-00			CAP.,FXD,CER DI:0.01UF,+80-20%,150V	72982	855-558Z5U-103Z
C3168	290-0270-00	B010100	B142899	CAP.,FXD,ELCTLT:8.2UF,20%,60V	56289	150D825X0060R2
C3168	290-0716-00	B142900	B209999	CAP.,FXD,ELCTLT:8.2UF,20%,75V	05397	T11C825M075AS
C3168	290-0769-00	B210000		CAP.,FXD,ELCTLT:10UF,+50-10%,100V	0000W	100TAL10
C3169	290-0194-00			CAP.,FXD,ELCTLT:10UF,+50-10%,100V	56289	30D106F100DC4
C3170	290-0270-00	B010100	B142899	CAP.,FXD,ELCTLT:8.2UF,20%,60V	56289	150D825X0060R2
C3170	290-0716-00	B142900	B209999	CAP.,FXD,ELCTLT:8.2UF,20%,75V	05397	T11C825M075AS
C3170	290-0769-00	B210000		CAP.,FXD,ELCTLT:10UF,+50-10%,100V	0000W	100TAL10
C3171	290-0194-00			CAP.,FXD,ELCTLT:10UF,+50-10%,100V	56289	30D106F100DC4
C3172	290-0425-00	B010100	B209999	CAP.,FXD,ELCTLT:100UF,20%,20V	90201	THF107M020P1G
C3172	290-0747-00	B210000		CAP.,FXD,ELCTLT:100UF,+50-10%,25V	56289	500D148
C3173	290-0519-00	B010100	B209999	CAP.,FXD,ELCTLT:100UF,20%,20V	90201	TDC107M020WLD
C3173	290-0770-00	B210000		CAP.,FXD,ELCTLT:100UF,+50-10%,25V	56289	502D230
C3174	290-0425-00	B010100	B209999	CAP.,FXD,ELCTLT:100UF,20%,20V	90201	THF107M020P1G
C3174	290-0747-00	B210000		CAP.,FXD,ELCTLT:100UF,+50-10%,25V	56289	500D148
C3175	290-0519-00	B010100	B209999	CAP.,FXD,ELCTLT:100UF,20%,20V	90201	TDC107M020WLD
C3175	290-0770-00	B210000		CAP.,FXD,ELCTLT:100UF,+50-10%,25V	56289	502D230
C3178	290-0425-00	B010100	B209999	CAP.,FXD,ELCTLT:100UF,20%,20V	90201	THF107M020P1G
C3178	290-0747-00	B210000		CAP.,FXD,ELCTLT:100UF,+50-10%,25V	56289	500D148
C3179	290-0531-00			CAP.,FXD,ELCTLT:100UF,20%,10V	90201	TDC107M010WLC
C3181	290-0425-00	B010100	B209999	CAP.,FXD,ELCTLT:100UF,20%,20V	90201	THF107M020P1G
C3181	290-0747-00	B210000		CAP.,FXD,ELCTLT:100UF,+50-10%,25V	56289	500D148
C3182	290-0531-00			CAP.,FXD,ELCTLT:100UF,20%,10V	90201	TDC107M010WLC
C3213	281-0543-00			CAP.,FXD,CER DI:270PF,10%,500V	72982	301055X5P271K
C3214	283-0000-00			CAP.,FXD,CER DI:0.001UF,+100-0%,500V	72982	831-516E102P
C3228	283-0000-00			CAP.,FXD,CER DI:0.001UF,+100-0%,500V	72982	831-516E102P
C3236	290-0531-00			CAP.,FXD,ELCTLT:100UF,20%,10V	90201	TDC107M010WLC
C3237	283-0000-00			CAP.,FXD,CER DI:0.001UF,+100-0%,500V	72982	831-516E102P
C3239	283-0000-00			CAP.,FXD,CER DI:0.001UF,+100-0%,500V	72982	831-516E102P
C3269	281-0523-00			CAP.,FXD,CER DI:100PF,+/-20PF,500V	72982	301-000U2M0101M
C3278	283-0000-00	B010100	B029999	CAP.,FXD,CER DI:0.001UF,+100-0%,500V	72982	831-516E102P
C3278	283-0110-00	B030000		CAP.,FXD,CER DI:0.005UF,+80-20%,150V	56289	19C242B
C3289	283-0000-00			CAP.,FXD,CER DI:0.001UF,+100-0%,500V	72982	831-516E102P
C3309	281-0629-00			CAP.,FXD,CER DI:33PF,5%,600V	72982	308-000C0G0330J
C3310	281-0540-00			CAP.,FXD,CER DI:51PF,5%,500V	72982	301-000U2J0510J

Replaceable Electrical Parts—7704A

Ckt No.	Tektronix Part No.	Serial/Model No. Eff	Dscont	Name & Description	Mfr Code	Mfr Part Number
C3312	283-0000-00			CAP.,FXD,CER DI:0.001UF,+100-0%,500V	72982	831-516E102P
C3315	283-0000-00			CAP.,FXD,CER DI:0.001UF,+100-0%,500V	72982	831-516E102P
C3326	283-0024-00			CAP.,FXD,CER DI:0.1UF,+80-20%,30V	72982	8131N075Z5U0104Z
C3330	281-0510-00			CAP.,FXD,CER DI:22PF,+/-4.4PF,500V	72982	301-000C0G0220M
C3354	283-0080-00			CAP.,FXD,CER DI:0.022UF,+80-20%,25V	56289	19C611
C3356	283-0000-00			CAP.,FXD,CER DI:0.001UF,+100-0%,500V	72982	831-516E102P
C3364	281-0603-00			CAP.,FXD,CER DI:39PF,5%,500V	72982	308-000C0G0390J
C3368	281-0546-00			CAP.,FXD,CER DI:330PF,10%,500V	04222	7001-1380
C3373	283-0003-00			CAP.,FXD,CER DI:0.01UF,+80-20%,150V	72982	855-558Z5U-103Z
C3391	283-0024-00			CAP.,FXD,CER DI:0.1UF,+80-20%,30V	72982	8131N075Z5U0104Z
C3395	290-0523-00			CAP.,FXD,ELCTLT:2.2UF,20%,20V	56289	196D225X0020HA1
C3396	290-0523-00			CAP.,FXD,ELCTLT:2.2UF,20%,20V	56289	196D225X0020HA1
C3401	283-0000-00			CAP.,FXD,CER DI:0.001UF,+100-0%,500V	72982	831-516E102P
C3407	283-0597-00			CAP.,FXD,MICA D:470PF,10%,300V	00853	D153E471K0
C3418	283-0004-00			CAP.,FXD,CER DI:0.02UF,+80-20%,150V	72982	855-558-Z5V0203Z
C3420	283-0597-00			CAP.,FXD,MICA D:470PF,10%,300V	00853	D153E471K0
C3429	283-0004-00			CAP.,FXD,CER DI:0.02UF,+80-20%,150V	72982	855-558-Z5V0203Z
C3434	285-0698-00			CAP.,FXD,PLSTC:0.0082UF,5%,100V	56289	410P82251
C3438	281-0612-00			CAP.,FXD,CER DI:5.6PF,+/-0.5PF,500V	72982	374-001C0H0569D
C3443	283-0103-00			CAP.,FXD,CER DI:180PF,5%,500V	56289	40C638
C3445	283-0103-00			CAP.,FXD,CER DI:180PF,5%,500V	56289	40C638
C3449	283-0000-00			CAP.,FXD,CER DI:0.001UF,+100-0%,500V	72982	831-516E102P
C3470	290-0523-00			CAP.,FXD,ELCTLT:2.2UF,20%,20V	56289	196D225X0020HA1
C3471	290-0517-00			CAP.,FXD,ELCTLT:6.8UF,20%,35V	56289	196D685X0035KA1
C3472	290-0523-00			CAP.,FXD,ELCTLT:2.2UF,20%,20V	56289	196D225X0020HA1
C3475	283-0000-00			CAP.,FXD,CER DI:0.001UF,+100-0%,500V	72982	831-516E102P
C3495	283-0054-00	XB205301		CAP.,FXD,CER DI:150PF,5%,200V	72982	855-535U2J151J
C4101	283-0057-00			CAP.,FXD,CER DI:0.1UF,+80-20%,200V	56289	274C10
C4104	283-0000-00			CAP.,FXD,CER DI:0.001UF,+100-0%,500V	72982	831-516E102P
C4106	283-0003-00			CAP.,FXD,CER DI:0.01UF,+80-20%,150V	72982	855-558Z5U-103Z
C4120	283-0000-00			CAP.,FXD,CER DI:0.001UF,+100-0%,500V	72982	831-516E102P
C4135	283-0092-00			CAP.,FXD,CER DI:0.03UF,+80-20%,200V	72982	845-534E303Z
C4140	283-0177-00			CAP.,FXD,CER DI:1UF,+80-20%,25V	72982	8131N039 E 105Z
C4142	283-0177-00			CAP.,FXD,CER DI:1UF,+80-20%,25V	72982	8131N039 E 105Z
C4157	283-0178-00	B010100	B194175	CAP.,FXD,CER DI:0.1UF,+80-20%,100V	72982	8131N145 E 104Z
C4157	283-0067-00	B194176		CAP.,FXD,CER DI:0.001UF,10%,200V	72982	835-515B102K
C4167	283-0080-00			CAP.,FXD,CER DI:0.022UF,+80-20%,25V	56289	19C611
C4193	283-0080-00			CAP.,FXD,CER DI:0.022UF,+80-20%,25V	56289	19C611
C4197	281-0670-00	XB040000		CAP.,FXD,CER DI:1.8PF,+/-0.1PF,500V	72982	374-005C0K0189B
C4201	290-0414-00			CAP.,FXD,ELCTLT:8UF,+50-10%,200V	90201	TTBROT200C1C3P
C4204	283-0105-00			CAP.,FXD,CER DI:0.01UF,+80-20%,2000V	56289	41C316
C4205	283-0105-00			CAP.,FXD,CER DI:0.01UF,+80-20%,2000V	56289	41C316
C4206	283-0272-00			CAP.,FXD,CER DI:0.0068UF,30%,4000V	72982	3888-510C 682M
C4207	283-0272-00			CAP.,FXD,CER DI:0.0068UF,30%,4000V	72982	3888-510C 682M
C4208	283-0272-00			CAP.,FXD,CER DI:0.0068UF,30%,4000V	72982	3888-510C 682M
C4215	283-0271-00			CAP.,FXD,CER DI:0.001UF,20%,4000V	56289	33C325
C4216	283-0271-00			CAP.,FXD,CER DI:0.001UF,20%,4000V	56289	33C325
C4217	283-0092-00			CAP.,FXD,CER DI:0.03UF,+80-20%,200V	72982	845-534E303Z
C4219	283-0272-00			CAP.,FXD,CER DI:0.0068UF,30%,4000V	72982	3888-510C 682M
C4221	283-0272-00			CAP.,FXD,CER DI:0.0068UF,30%,4000V	72982	3888-510C 682M
C4230	283-0279-00			CAP.,FXD,CER DI:0.001UF,20%,3000V	56289	55C153
C4231	283-0279-00			CAP.,FXD,CER DI:0.001UF,20%,3000V	56289	55C153
C4244	283-0271-00			CAP.,FXD,CER DI:0.001UF,20%,4000V	56289	33C325

Ckt No.	Tektronix Part No.	Serial/Model No. Eff	Dscont	Name & Description	Mfr Code	Mfr Part Number
C4250	290-0425-00			CAP.,FXD,ELCTLT:100UF,20%,20V	90201	THF107M020P1G
C4252	290-0531-00			CAP.,FXD,ELCTLT:100UF,20%,10V	90201	TDC107M010WLC
C4312	281-0540-00	B010100	B099999	CAP.,FXD,CER DI:51PF,5%,500V	72982	301-000U2J0510J
C4312	281-0550-00	B100000	B109999	CAP.,FXD,CER DI:120PF,10%,500V	04222	7001-1373
C4312	281-0524-00	B110000		CAP.,FXD,CER DI:150PF,+/-30PF,500V	04222	7001-1381
C4315	281-0542-00			CAP.,FXD,CER DI:18PF,10%,500V	72982	301-002C0G0180K
C4321	283-0000-00			CAP.,FXD,CER DI:0.001UF,+100-0%,500V	72982	831-516E102P
C4325	283-0083-00			CAP.,FXD,CER DI:0.0047UF,20%,500V	72982	811-565C472J
C4329	281-0501-00	B010100	B109999	CAP.,FXD,CER DI:4.7PF,+/-1PF,500V	72982	301-000S2H0479F
C4329	281-0504-00	B110000		CAP.,FXD,CER DI:10PF,+/-1PF,500V	72982	301-055C0G0100F
C4331	283-0000-00			CAP.,FXD,CER DI:0.001UF,+100-0%,500V	72982	831-516E102P
C4335	283-0041-00			CAP.,FXD,CER DI:0.0033UF,5%,500V	72982	841-541B332J
C4339	281-0629-00			CAP.,FXD,CER DI:33PF,5%,600V	72982	308-000C0G0330J
C4342	283-0092-00			CAP.,FXD,CER DI:0.03UF,+80-20%,200V	72982	845-534E303Z
C4354	283-0178-00	B010100	B109999	CAP.,FXD,CER DI:0.1UF,+80-20%,100V	72982	8131N145 E 104Z
C4354	283-0211-00	B110000		CAP.,FXD,CER DI:0.1UF,10%,200V	72982	8141N227C104K
C4356	290-0534-00			CAP.,FXD,ELCTLT:1UF,20%,35V	56289	196D105X0035HA1
C4364	283-0178-00	B010100	B109999	CAP.,FXD,CER DI:0.1UF,+80-20%,100V	72982	8131N145 E 104Z
C4364	283-0211-00	B110000		CAP.,FXD,CER DI:0.1UF,10%,200V	72982	8141N227C104K
C4366	290-0534-00			CAP.,FXD,ELCTLT:1UF,20%,35V	56289	196D105X0035HA1
C4373	290-0305-00			CAP.,FXD,ELCTLT:3UF,20%,150V	56289	109D305X0150C2
C4374	281-0064-00			CAP.,VAR,PLSTC:0.25-1.5PF,600V	72982	530-002
C4380	283-0080-00			CAP.,FXD,CER DI:0.022UF,+80-20%,25V	56289	19C611
C4385	281-0123-00			CAP.,VAR,CER DI:5-25PF,100V	72982	518-000A5-25
C4391	281-0064-00			CAP.,VAR,PLSTC:0.25-1.5PF,600V	72982	530-002
C4394	290-0305-00			CAP.,FXD,ELCTLT:3UF,20%,150V	56289	109D305X0150C2
C4397	283-0010-00			CAP.,FXD,CER DI:0.05UF,+100-20%,50V	56289	273C20
C4398	290-0527-00			CAP.,FXD,ELCTLT:15UF,20%,20V	90201	TDC156M020FL
C4399	290-0527-00			CAP.,FXD,ELCTLT:15UF,20%,20V	90201	TDC156M020FL
C4401	281-0122-00			CAP.,VAR,CER DI:2.5-9PF,100V	72982	518-000A2.5-9
C4417	283-0000-00			CAP.,FXD,CER DI:0.001UF,+100-0%,500V	72982	831-516E102P
C4419	283-0000-00			CAP.,FXD,CER DI:0.001UF,+100-0%,500V	72982	831-516E102P
C4423	281-0589-00			CAP.,FXD,CER DI:170PF,5%,500V	72982	301000Z5D171J
C4424	281-0158-00			CAP.,VAR,CER DI:7-45PF,50V	73899	DVJ-5006
C4427	281-0122-00			CAP.,VAR,CER DI:2.5-9PF,100V	72982	518-000A2.5-9
C4451	281-0580-00			CAP.,FXD,CER DI:470PF,10%,500V	04222	7001-1374
C4453	283-0001-00	B010100	B010129	CAP.,FXD,CER DI:0.005UF,+100-0%,500V	72982	831-559E502P
C4453	283-0328-00	B010130		CAP.,FXD,CER DI:0.03UF,+80-20%,200V	72982	8131N225651303Z
C4455	283-0080-00			CAP.,FXD,CER DI:0.022UF,+80-20%,25V	56289	19C611
C4458	283-0000-00			CAP.,FXD,CER DI:0.001UF,+100-0%,500V	72982	831-516E102P
C4461	283-0119-00	B010100	B010129	CAP.,FXD,CER DI:2200PF,5%,200V	72982	855-535B222J
C4461	283-0238-00	B010130		CAP.,FXD,CER DI:0.01UF,10%,50V	72982	8121N075X7R0103K
C4463	283-0003-00	B010100	B010129	CAP.,FXD,CER DI:0.01UF,+80-20%,150V	72982	855-558Z5U-103Z
C4463	283-0176-00	B010130		CAP.,FXD,CER DI:0.0022UF,20%,50V	72982	8121M050W5R222M
C4465	283-0111-00	B010100	B119999	CAP.,FXD,CER DI:0.1UF,20%,50V	72982	8121-N088Z5U104M
C4465	283-0111-00	B120000		CAP.,FXD,CER DI:0.1UF,20%,50V	72982	8121-N088Z5U104M
C5013	283-0000-00			CAP.,FXD,CER DI:0.001UF,+100-0%,500V	72982	831-516E102P
C5020	283-0044-00	B010100	B091620X	CAP.,FXD,CER DI:0.001UF,3000V	72982	3903BW002Y5S102M
C5022	283-0044-00	B010100	B091620X	CAP.,FXD,CER DI:0.001UF,3000V	72982	3903BW002Y5S102M
C32119	283-0067-00	B010100	B069999	CAP.,FXD,CER DI:0.001UF,10%,200V	72982	835-515B102K
C32119	283-0110-00	B070000	B099999	CAP.,FXD,CER DI:0.005UF,+80-20%,150V	56289	19C242B
C32119	283-0028-00	B100000		CAP.,FXD,CER DI:0.0022UF,20%,50V	56289	19C606
C32127	283-0003-00			CAP.,FXD,CER DI:0.01UF,+80-20%,150V	72982	855-558Z5U-103Z

Replaceable Electrical Parts—7704A

Ckt No.	Tektronix Part No.	Serial/Model No. Eff	Dscont	Name & Description	Mfr Code	Mfr Part Number
C32134	283-0111-00	B010100	B099999	CAP.,FXD,CER DI:0.1UF,20%,50V	72982	8121-N088Z5U104M
C32134	283-0208-00	B100000		CAP.,FXD,CER DI:0.22UF,10%,200V	72982	8151N230 C 224K
C32141	283-0000-00			CAP.,FXD,CER DI:0.001UF,+100-0%,500V	72982	831-516E102P
C41105	283-0000-00			CAP.,FXD,CER DI:0.001UF,+100-0%,500V	72982	831-516E102P
C41107	283-0110-00			CAP.,FXD,CER DI:0.005UF,+80-20%,150V	56289	19C242B
C41109	281-0064-00			CAP.,VAR,PLSTC:0.25-1.5PF,600V	72982	530-002
C41111	283-0178-00	B010100	B109999	CAP.,FXD,CER DI:0.1UF,+80-20%,100V	72982	8131N145 E 104Z
C41111	283-0211-00	B110000		CAP.,FXD,CER DI:0.1UF,10%,200V	72982	8141N227C104K
C41113	283-0178-00	B010100	B109999	CAP.,FXD,CER DI:0.1UF,+80-20%,100V	72982	8131N145 E 104Z
C41113	283-0211-00	B110000		CAP.,FXD,CER DI:0.1UF,10%,200V	72982	8141N227C104K
C41125	281-0526-00			CAP.,FXD,CER DI:1.5PF,+/-0.5PF,500V	72982	301-000S2K0159D
C41133	283-0178-00			CAP.,FXD,CER DI:0.1UF,+80-20%,100V	72982	8131N145 E 104Z
C41150	283-0092-00			CAP.,FXD,CER DI:0.03UF,+80-20%,200V	72982	845-534E303Z
C41151	281-0629-00			CAP.,FXD,CER DI:33PF,5%,600V	72982	308-000C0G0330J
C41163	290-0523-00			CAP.,FXD,ELCTLT:2.2UF,20%,20V	56289	196D225X0020HA1
C41165	283-0178-00			CAP.,FXD,CER DI:0.1UF,+80-20%,100V	72982	8131N145 E 104Z
C41167	283-0178-00			CAP.,FXD,CER DI:0.1UF,+80-20%,100V	72982	8131N145 E 104Z
C41169	290-0523-00			CAP.,FXD,ELCTLT:2.2UF,20%,20V	56289	196D225X0020HA1
C41171	283-0003-00			CAP.,FXD,CER DI:0.01UF,+80-20%,150V	72982	855-558Z5U-103Z
C41175	283-0003-00			CAP.,FXD,CER DI:0.01UF,+80-20%,150V	72982	855-558Z5U-103Z
C41179	283-0003-00			CAP.,FXD,CER DI:0.01UF,+80-20%,150V	72982	855-558Z5U-103Z
C41185	283-0178-00			CAP.,FXD,CER DI:0.1UF,+80-20%,100V	72982	8131N145 E 104Z
CR1064	152-0141-02			SEMICONV DEVICE:SILICON,30V,150MA	07910	1N4152
CR1065	152-0141-02			SEMICONV DEVICE:SILICON,30V,150MA	07910	1N4152
CR1067	152-0141-02			SEMICONV DEVICE:SILICON,30V,150MA	07910	1N4152
CR1068	152-0141-02			SEMICONV DEVICE:SILICON,30V,150MA	07910	1N4152
CR2007	152-0141-02			SEMICONV DEVICE:SILICON,30V,150MA	07910	1N4152
CR2008	152-0141-02			SEMICONV DEVICE:SILICON,30V,150MA	07910	1N4152
CR2009	152-0141-02			SEMICONV DEVICE:SILICON,30V,150MA	07910	1N4152
CR2014	152-0141-02			SEMICONV DEVICE:SILICON,30V,150MA	07910	1N4152
CR2015	152-0141-02			SEMICONV DEVICE:SILICON,30V,150MA	07910	1N4152
CR2016	152-0141-02			SEMICONV DEVICE:SILICON,30V,150MA	07910	1N4152
CR2017	152-0141-02			SEMICONV DEVICE:SILICON,30V,150MA	07910	1N4152
CR2018	152-0141-02			SEMICONV DEVICE:SILICON,30V,150MA	07910	1N4152
CR2020	152-0141-02			SEMICONV DEVICE:SILICON,30V,150MA	07910	1N4152
CR2021	152-0141-02			SEMICONV DEVICE:SILICON,30V,150MA	07910	1N4152
CR2031	152-0141-02			SEMICONV DEVICE:SILICON,30V,150MA	07910	1N4152
CR2033	152-0141-02			SEMICONV DEVICE:SILICON,30V,150MA	07910	1N4152
CR2035	152-0141-02			SEMICONV DEVICE:SILICON,30V,150MA	07910	1N4152
CR2037	152-0141-02			SEMICONV DEVICE:SILICON,30V,150MA	07910	1N4152
CR2041	152-0141-02			SEMICONV DEVICE:SILICON,30V,150MA	07910	1N4152
CR2043	152-0141-02			SEMICONV DEVICE:SILICON,30V,150MA	07910	1N4152
CR2045	152-0141-02			SEMICONV DEVICE:SILICON,30V,150MA	07910	1N4152
CR2047	152-0141-02			SEMICONV DEVICE:SILICON,30V,150MA	07910	1N4152
CR2051	152-0141-02			SEMICONV DEVICE:SILICON,30V,150MA	07910	1N4152
CR2060	152-0141-02			SEMICONV DEVICE:SILICON,30V,150MA	07910	1N4152
CR2061	152-0141-02			SEMICONV DEVICE:SILICON,30V,150MA	07910	1N4152
CR2064	152-0141-02			SEMICONV DEVICE:SILICON,30V,150MA	07910	1N4152
CR2067	152-0141-02			SEMICONV DEVICE:SILICON,30V,150MA	07910	1N4152
CR2202	152-0141-02			SEMICONV DEVICE:SILICON,30V,150MA	07910	1N4152
CR2203	152-0141-02			SEMICONV DEVICE:SILICON,30V,150MA	07910	1N4152
CR2209	152-0333-00	XB160000		SEMICONV DEVICE:SILICON,55V,200MA	80009	152-0333-00

Ckt No.	Tektronix Part No.	Serial/Model No. Eff	Dscont	Name & Description	Mfr Code	Mfr Part Number
CR2210	152-0333-00	XB160000		SEMICON D DEVICE: SILICON, 55V, 200MA	80009	152-0333-00
CR2211	152-0333-00	XB160000		SEMICON D DEVICE: SILICON, 55V, 200MA	80009	152-0333-00
CR2212	152-0333-00	XB160000		SEMICON D DEVICE: SILICON, 55V, 200MA	80009	152-0333-00
CR2213	152-0333-00	XB160000		SEMICON D DEVICE: SILICON, 55V, 200MA	80009	152-0333-00
CR2214	152-0333-00	XB160000		SEMICON D DEVICE: SILICON, 55V, 200MA	80009	152-0333-00
CR2215	152-0333-00	XB160000		SEMICON D DEVICE: SILICON, 55V, 200MA	80009	152-0333-00
CR2216	152-0333-00	XB160000		SEMICON D DEVICE: SILICON, 55V, 200MA	80009	152-0333-00
CR2217	152-0333-00	XB160000		SEMICON D DEVICE: SILICON, 55V, 200MA	80009	152-0333-00
CR2218	152-0333-00	XB160000		SEMICON D DEVICE: SILICON, 55V, 200MA	80009	152-0333-00
CR2219	152-0333-00	XB160000		SEMICON D DEVICE: SILICON, 55V, 200MA	80009	152-0333-00
CR2220	152-0333-00	XB160000		SEMICON D DEVICE: SILICON, 55V, 200MA	80009	152-0333-00
CR2221	152-0333-00	XB160000		SEMICON D DEVICE: SILICON, 55V, 200MA	80009	152-0333-00
CR2222	152-0333-00	XB160000		SEMICON D DEVICE: SILICON, 55V, 200MA	80009	152-0333-00
CR2223	152-0333-00	XB160000		SEMICON D DEVICE: SILICON, 55V, 200MA	80009	152-0333-00
CR2224	152-0333-00	XB160000		SEMICON D DEVICE: SILICON, 55V, 200MA	80009	152-0333-00
CR2225	152-0333-00	XB160000		SEMICON D DEVICE: SILICON, 55V, 200MA	80009	152-0333-00
CR2226	152-0333-00	XB160000		SEMICON D DEVICE: SILICON, 55V, 200MA	80009	152-0333-00
CR2227	152-0333-00	XB160000		SEMICON D DEVICE: SILICON, 55V, 200MA	80009	152-0333-00
CR2228	152-0333-00	XB160000		SEMICON D DEVICE: SILICON, 55V, 200MA	80009	152-0333-00
CR2229	152-0333-00	XB160000		SEMICON D DEVICE: SILICON, 55V, 200MA	80009	152-0333-00
CR2230	152-0333-00	XB160000		SEMICON D DEVICE: SILICON, 55V, 200MA	80009	152-0333-00
CR2231	152-0333-00	XB160000		SEMICON D DEVICE: SILICON, 55V, 200MA	80009	152-0333-00
CR2232	152-0333-00	XB160000		SEMICON D DEVICE: SILICON, 55V, 200MA	80009	152-0333-00
CR2233	152-0333-00	XB160000		SEMICON D DEVICE: SILICON, 55V, 200MA	80009	152-0333-00
CR2234	152-0333-00	XB160000		SEMICON D DEVICE: SILICON, 55V, 200MA	80009	152-0333-00
CR2235	152-0333-00	XB160000		SEMICON D DEVICE: SILICON, 55V, 200MA	80009	152-0333-00
CR2236	152-0333-00	XB160000		SEMICON D DEVICE: SILICON, 55V, 200MA	80009	152-0333-00
CR2237	152-0333-00	XB160000		SEMICON D DEVICE: SILICON, 55V, 200MA	80009	152-0333-00
CR2238	152-0333-00	XB160000		SEMICON D DEVICE: SILICON, 55V, 200MA	80009	152-0333-00
CR2239	152-0333-00	XB160000		SEMICON D DEVICE: SILICON, 55V, 200MA	80009	152-0333-00
CR2240	152-0333-00	XB160000		SEMICON D DEVICE: SILICON, 55V, 200MA	80009	152-0333-00
CR2244	152-0141-02			SEMICON D DEVICE: SILICON, 30V, 150MA	07910	1N4152
CR2444	152-0141-02			SEMICON D DEVICE: SILICON, 30V, 150MA	07910	1N4152
CR2449	152-0141-02			SEMICON D DEVICE: SILICON, 30V, 150MA	07910	1N4152
CR2501	152-0141-02			SEMICON D DEVICE: SILICON, 30V, 150MA	07910	1N4152
CR2502	152-0141-02			SEMICON D DEVICE: SILICON, 30V, 150MA	07910	1N4152
CR2524	152-0141-02			SEMICON D DEVICE: SILICON, 30V, 150MA	07910	1N4152
CR2525	152-0141-02			SEMICON D DEVICE: SILICON, 30V, 150MA	07910	1N4152
CR2526	152-0141-02			SEMICON D DEVICE: SILICON, 30V, 150MA	07910	1N4152
CR2552	152-0141-02			SEMICON D DEVICE: SILICON, 30V, 150MA	07910	1N4152
CR2553	152-0141-02			SEMICON D DEVICE: SILICON, 30V, 150MA	07910	1N4152
CR2571	152-0141-02			SEMICON D DEVICE: SILICON, 30V, 150MA	07910	1N4152
CR2572	152-0141-02			SEMICON D DEVICE: SILICON, 30V, 150MA	07910	1N4152
CR2585	152-0141-02			SEMICON D DEVICE: SILICON, 30V, 150MA	07910	1N4152
CR2594	152-0141-02			SEMICON D DEVICE: SILICON, 30V, 150MA	07910	1N4152
CR2596	152-0141-02			SEMICON D DEVICE: SILICON, 30V, 150MA	07910	1N4152
CR3015	152-0396-01			SEMICON D DEVICE: SILICON, 400V, 3A	12969	652-821
CR3032	152-0107-00			SEMICON D DEVICE: SILICON, 400V, 400MA	80009	152-0107-00
CR3034	152-0400-00			SEMICON D DEVICE: SILICON, 400V, 1A	80009	152-0400-00
CR3040	152-0401-00			SEMICON D DEVICE: SILICON, 3-LAYER, TRIGGER	04713	1N5761
CR3043	152-0107-00			SEMICON D DEVICE: SILICON, 400V, 400MA	80009	152-0107-00
CR3045	152-0400-00			SEMICON D DEVICE: SILICON, 400V, 1A	80009	152-0400-00
CR3046	152-0107-00			SEMICON D DEVICE: SILICON, 400V, 400MA	80009	152-0107-00

Replaceable Electrical Parts—7704A

Ckt No.	Tektronix Part No.	Serial/Model No. Eff	Dscont	Name & Description	Mfr Code	Mfr Part Number
CR3050	152-0061-00			SEMICON D DEVICE:SILICON,175V,100MA	80009	152-0061-00
CR3057	152-0107-00			SEMICON D DEVICE:SILICON,400V,400MA	80009	152-0107-00
CR3101	152-0061-00			SEMICON D DEVICE:SILICON,175V,100MA	80009	152-0061-00
CR3102	152-0061-00			SEMICON D DEVICE:SILICON,175V,100MA	80009	152-0061-00
CR3103	152-0141-02			SEMICON D DEVICE:SILICON,30V,150MA	07910	1N4152
CR3106	152-0141-02			SEMICON D DEVICE:SILICON,30V,150MA	07910	1N4152
CR3108	152-0141-02			SEMICON D DEVICE:SILICON,30V,150MA	07910	1N4152
CR3130	152-0333-00			SEMICON D DEVICE:SILICON,55V,200MA	80009	152-0333-00
CR3131	152-0333-00			SEMICON D DEVICE:SILICON,55V,200MA	80009	152-0333-00
CR3132	152-0333-00			SEMICON D DEVICE:SILICON,55V,200MA	80009	152-0333-00
CR3133	152-0333-00			SEMICON D DEVICE:SILICON,55V,200MA	80009	152-0333-00
CR3138	152-0333-00			SEMICON D DEVICE:SILICON,55V,200MA	80009	152-0333-00
CR3139	152-0333-00			SEMICON D DEVICE:SILICON,55V,200MA	80009	152-0333-00
CR3140	152-0333-00			SEMICON D DEVICE:SILICON,55V,200MA	80009	152-0333-00
CR3144	152-0141-02			SEMICON D DEVICE:SILICON,30V,150MA	07910	1N4152
CR3163	152-0413-00			SEMICON D DEVICE:SILICON,400V,750MA	80009	152-0413-00
CR3165	152-0413-00			SEMICON D DEVICE:SILICON,400V,750MA	80009	152-0413-00
CR3167	152-0413-00			SEMICON D DEVICE:SILICON,400V,750MA	80009	152-0413-00
CR3168	152-0413-00			SEMICON D DEVICE:SILICON,400V,750MA	80009	152-0413-00
CR3172	152-0412-00			SEMICON D DEVICE:SILICON,50V,3A	80009	152-0412-00
CR3173	152-0412-00			SEMICON D DEVICE:SILICON,50V,3A	80009	152-0412-00
CR3174	152-0412-00			SEMICON D DEVICE:SILICON,50V,3A	80009	152-0412-00
CR3175	152-0412-00			SEMICON D DEVICE:SILICON,50V,3A	80009	152-0412-00
CR3178	152-0412-00			SEMICON D DEVICE:SILICON,50V,3A	80009	152-0412-00
CR3179	152-0412-00			SEMICON D DEVICE:SILICON,50V,3A	80009	152-0412-00
CR3181	152-0502-00			SEMICON D DEVICE:SILICON,20V,5A	04713	1N5823
CR3182	152-0502-00			SEMICON D DEVICE:SILICON,20V,5A	04713	1N5823
CR3202	152-0141-02			SEMICON D DEVICE:SILICON,30V,150MA	07910	1N4152
CR3209	152-0141-02			SEMICON D DEVICE:SILICON,30V,150MA	07910	1N4152
CR3211	152-0141-02			SEMICON D DEVICE:SILICON,30V,150MA	07910	1N4152
CR3212	152-0141-02			SEMICON D DEVICE:SILICON,30V,150MA	07910	1N4152
CR3221	152-0066-01			SEMICON D DEVICE:SILICON,400V,1A	80009	152-0066-01
CR3226	152-0141-02			SEMICON D DEVICE:SILICON,30V,150MA	07910	1N4152
CR3235	152-0141-02			SEMICON D DEVICE:SILICON,30V,150MA	07910	1N4152
CR3241	152-0066-01			SEMICON D DEVICE:SILICON,400V,1A	80009	152-0066-01
CR3245	152-0141-02			SEMICON D DEVICE:SILICON,30V,150MA	07910	1N4152
CR3246	152-0141-02			SEMICON D DEVICE:SILICON,30V,150MA	07910	1N4152
CR3261	152-0066-01			SEMICON D DEVICE:SILICON,400V,1A	80009	152-0066-01
CR3274	152-0141-02			SEMICON D DEVICE:SILICON,30V,150MA	07910	1N4152
CR3275	152-0141-02			SEMICON D DEVICE:SILICON,30V,150MA	07910	1N4152
CR3277	152-0141-02			SEMICON D DEVICE:SILICON,30V,150MA	07910	1N4152
CR3278	152-0141-02			SEMICON D DEVICE:SILICON,30V,150MA	07910	1N4152
CR3281	152-0141-02			SEMICON D DEVICE:SILICON,30V,150MA	07910	1N4152
CR3293	152-0066-01			SEMICON D DEVICE:SILICON,400V,1A	80009	152-0066-01
CR3315	152-0141-02			SEMICON D DEVICE:SILICON,30V,150MA	07910	1N4152
CR3317	152-0141-02			SEMICON D DEVICE:SILICON,30V,150MA	07910	1N4152
CR3326	152-0141-02			SEMICON D DEVICE:SILICON,30V,150MA	07910	1N4152
CR3333	152-0141-02			SEMICON D DEVICE:SILICON,30V,150MA	07910	1N4152
CR3361	152-0141-02			SEMICON D DEVICE:SILICON,30V,150MA	07910	1N4152
CR3363	152-0141-02			SEMICON D DEVICE:SILICON,30V,150MA	07910	1N4152
CR3364	152-0141-02			SEMICON D DEVICE:SILICON,30V,150MA	07910	1N4152
CR3393	152-0141-02			SEMICON D DEVICE:SILICON,30V,150MA	07910	1N4152
CR3416	152-0141-02			SEMICON D DEVICE:SILICON,30V,150MA	07910	1N4152

Ckt No.	Tektronix Part No.	Serial/Model No. Eff	Dscont	Name & Description	Mfr Code	Mfr Part Number
CR3431	152-0141-02			SEMICON D DEVICE:SILICON,30V,150MA	07910	1N4152
CR3432	152-0141-02			SEMICON D DEVICE:SILICON,30V,150MA	07910	1N4152
CR3433	152-0141-02			SEMICON D DEVICE:SILICON,30V,150MA	07910	1N4152
CR3438	152-0141-02			SEMICON D DEVICE:SILICON,30V,150MA	07910	1N4152
CR3439	152-0141-02			SEMICON D DEVICE:SILICON,30V,150MA	07910	1N4152
CR3441	152-0141-02			SEMICON D DEVICE:SILICON,30V,150MA	07910	1N4152
CR3442	152-0141-02			SEMICON D DEVICE:SILICON,30V,150MA	07910	1N4152
CR3443	152-0141-02			SEMICON D DEVICE:SILICON,30V,150MA	07910	1N4152
CR3445	152-0141-02			SEMICON D DEVICE:SILICON,30V,150MA	07910	1N4152
CR3447	152-0141-02			SEMICON D DEVICE:SILICON,30V,150MA	07910	1N4152
CR4101	152-0066-01			SEMICON D DEVICE:SILICON,400V,1A	80009	152-0066-01
CR4110	152-0141-02			SEMICON D DEVICE:SILICON,30V,150MA	07910	1N4152
CR4112	152-0141-02			SEMICON D DEVICE:SILICON,30V,150MA	07910	1N4152
CR4121	152-0061-00			SEMICON D DEVICE:SILICON,175V,100MA	80009	152-0061-00
CR4122	152-0061-00			SEMICON D DEVICE:SILICON,175V,100MA	80009	152-0061-00
CR4145	152-0141-02			SEMICON D DEVICE:SILICON,30V,150MA	07910	1N4152
CR4150	152-0141-02			SEMICON D DEVICE:SILICON,30V,150MA	07910	1N4152
CR4151	152-0141-02			SEMICON D DEVICE:SILICON,30V,150MA	07910	1N4152
CR4171	152-0141-02			SEMICON D DEVICE:SILICON,30V,150MA	07910	1N4152
CR4175	152-0141-02			SEMICON D DEVICE:SILICON,30V,150MA	07910	1N4152
CR4177	152-0141-02			SEMICON D DEVICE:SILICON,30V,150MA	07910	1N4152
CR4195	152-0141-02			SEMICON D DEVICE:SILICON,30V,150MA	07910	1N4152
CR4201	152-0413-00			SEMICON D DEVICE:SILICON,400V,750MA	80009	152-0413-00
CR4202	152-0413-00			SEMICON D DEVICE:SILICON,400V,750MA	80009	152-0413-00
CR4203	152-0413-00			SEMICON D DEVICE:SILICON,400V,750MA	80009	152-0413-00
CR4204	152-0413-00			SEMICON D DEVICE:SILICON,400V,750MA	80009	152-0413-00
CR4205	152-0409-00			SEMICON D DEVICE:SILICON,12,000V,5MA	80009	152-0409-00
CR4206	152-0409-00			SEMICON D DEVICE:SILICON,12,000V,5MA	80009	152-0409-00
CR4215	152-0242-00			SEMICON D DEVICE:SILICON,225V,200MA	12969	NDP341
CR4216	152-0242-00			SEMICON D DEVICE:SILICON,225V,200MA	12969	NDP341
CR4217	152-0242-00			SEMICON D DEVICE:SILICON,225V,200MA	12969	NDP341
CR4218	152-0242-00			SEMICON D DEVICE:SILICON,225V,200MA	12969	NDP341
CR4230	152-0242-00			SEMICON D DEVICE:SILICON,225V,200MA	12969	NDP341
CR4231	152-0242-00			SEMICON D DEVICE:SILICON,225V,200MA	12969	NDP341
CR4233	152-0242-00			SEMICON D DEVICE:SILICON,225V,200MA	12969	NDP341
CR4235	152-0242-00			SEMICON D DEVICE:SILICON,225V,200MA	12969	NDP341
CR4250	152-0413-00			SEMICON D DEVICE:SILICON,400V,750MA	80009	152-0413-00
CR4256	152-0075-00	B010100	B109999	SEMICON D DEVICE:GE,25V,40MA	80009	152-0075-00
CR4256	152-0141-02	B110000		SEMICON D DEVICE:SILICON,30V,150MA	07910	1N4152
CR4258	152-0141-02	B010100	B109999	SEMICON D DEVICE:SILICON,30V,150MA	07910	1N4152
CR4258	152-0075-00	B110000		SEMICON D DEVICE:GE,25V,40MA	80009	152-0075-00
CR4323	152-0153-00			SEMICON D DEVICE:SILICON,15V,50MA	80009	152-0153-00
CR4333	152-0153-00			SEMICON D DEVICE:SILICON,15V,50MA	80009	152-0153-00
CR4340	152-0153-00			SEMICON D DEVICE:SILICON,15V,50MA	80009	152-0153-00
CR4342	152-0153-00			SEMICON D DEVICE:SILICON,15V,50MA	80009	152-0153-00
CR4344	152-0333-00			SEMICON D DEVICE:SILICON,55V,200MA	80009	152-0333-00
CR4346	152-0333-00			SEMICON D DEVICE:SILICON,55V,200MA	80009	152-0333-00
CR4348	152-0141-02			SEMICON D DEVICE:SILICON,30V,150MA	07910	1N4152
CR4360	152-0141-02			SEMICON D DEVICE:SILICON,30V,150MA	07910	1N4152
CR4419	152-0141-02	XB140000		SEMICON D DEVICE:SILICON,30V,150MA	07910	1N4152
CR4473	152-0141-02			SEMICON D DEVICE:SILICON,30V,150MA	07910	1N4152
CR32110	152-0141-02			SEMICON D DEVICE:SILICON,30V,150MA	07910	1N4152
CR32113	152-0141-02			SEMICON D DEVICE:SILICON,30V,150MA	07910	1N4152

Replaceable Electrical Parts—7704A

Ckt No.	Tektronix Part No.	Serial/Model No. Eff	Dscont	Name & Description	Mfr Code	Mfr Part Number
CR32114	152-0141-02			SEMICON D DEVICE:SILICON,30V,150MA	07910	1N4152
CR32123	152-0141-02			SEMICON D DEVICE:SILICON,30V,150MA	07910	1N4152
CR32125	152-0141-02			SEMICON D DEVICE:SILICON,30V,150MA	07910	1N4152
CR32128	152-0233-00			SEMICON D DEVICE:SILICON,85V,100MA	80009	152-0233-00
CR32130	152-0141-02			SEMICON D DEVICE:SILICON,30V,150MA	07910	1N4152
CR32139	152-0066-01			SEMICON D DEVICE:SILICON,400V,1A	80009	152-0066-01
CR41101	152-0141-02	XB200000		SEMICON D DEVICE:SILICON,30V,150MA	07910	1N4152
CR41103	152-0141-02			SEMICON D DEVICE:SILICON,30V,150MA	07910	1N4152
CR41107	152-0141-02	XB200000		SEMICON D DEVICE:SILICON,30V,150MA	07910	1N4152
CR41110	152-0141-02			SEMICON D DEVICE:SILICON,30V,150MA	07910	1N4152
CR41111	152-0141-02			SEMICON D DEVICE:SILICON,30V,150MA	07910	1N4152
CR41114	152-0141-02	XB200000		SEMICON D DEVICE:SILICON,30V,150MA	07910	1N4152
CR41121	152-0333-00			SEMICON D DEVICE:SILICON,55V,200MA	80009	152-0333-00
CR41129	152-0141-02			SEMICON D DEVICE:SILICON,30V,150MA	07910	1N4152
CR41137	152-0141-02			SEMICON D DEVICE:SILICON,30V,150MA	07910	1N4152
CR41155	152-0061-00			SEMICON D DEVICE:SILICON,175V,100MA	80009	152-0061-00
CR41157	152-0107-00			SEMICON D DEVICE:SILICON,400V,400MA	80009	152-0107-00
CR41183	152-0141-02			SEMICON D DEVICE:SILICON,30V,150MA	07910	1N4152
DL5050	119-0337-00			DELAY LINE,ELEC:	80009	119-0337-00
DS111	150-0057-03			LAMP ASSEMBLY:INCANDESCENT	80009	150-0057-03
DS112	150-0057-03			LAMP ASSEMBLY:INCANDESCENT	80009	150-0057-03
DS113	150-0057-03			LAMP ASSEMBLY:INCANDESCENT	80009	150-0057-03
DS114	150-0057-03			LAMP ASSEMBLY:INCANDESCENT	80009	150-0057-03
DS115	150-0057-03			LAMP ASSEMBLY:INCANDESCENT	80009	150-0057-03
DS121	150-0057-03			LAMP ASSEMBLY:INCANDESCENT	80009	150-0057-03
DS122	150-0057-03			LAMP ASSEMBLY:INCANDESCENT	80009	150-0057-03
DS123	150-0057-03			LAMP ASSEMBLY:INCANDESCENT	80009	150-0057-03
DS124	150-0057-03			LAMP ASSEMBLY:INCANDESCENT	80009	150-0057-03
DS131	150-0048-01	XB010120		LAMP,INCAND:5V,0.06A,SEL	08806	683AS15
DS141	150-0048-01	XB010120		LAMP,INCAND:5V,0.06A,SEL	08806	683AS15
DS3008	119-0181-00			SURGE VOLTAGE P:230VAC,+/-15%	80009	119-0181-00
DS3013	119-0181-00			SURGE VOLTAGE P:230VAC,+/-15%	80009	119-0181-00
DS3019	150-0035-00			LAMP,GLOW:90V,0.3MA	53944	ALB-3
DS4216	150-0027-00			LAMP,GLOW:90V,3MA	08806	5AB-T
DS4218	150-0027-00			LAMP,GLOW:90V,3MA	08806	5AB-T
DS4237	150-0027-00			LAMP,GLOW:90V,3MA	08806	5AB-T
DS4239	150-0027-00			LAMP,GLOW:90V,3MA	08806	5AB-T
DS5001	150-0029-00			LAMP,INCAND:6.3V,0.20A	08806	349
DS5002	150-0029-00			LAMP,INCAND:6.3V,0.20A	08806	349
DS5003	150-0029-00			LAMP,INCAND:6.3V,0.20A	08806	349
F2020	159-0082-00	B010100	B019999X	FUSE,CARTRIDGE:1AG,15A,32V,FAST BLOW	71400	GKN15
F3003	159-0021-00			FUSE,CARTRIDGE:3AG,2A,250V,FAST-BLOW	71400	AGC 2
F5001	159-0017-00			FUSE,CARTRIDGE:3AG,4A,250V,FAST BLOW	71400	MTH4
FL5020	119-0389-00	XB091621		FILTER,RAD INTE:115/230V,3A	02777	F11935-3
J1	131-0767-02	B010100	B059999	CONNECTOR,RCPT,:76 CONTACT	80009	131-0767-02
J1	131-0767-08	B060000		CONNECTOR,RCPT,:PLUG-IN CKT BD,70 CONTACT	80009	131-0767-08
J2	131-0767-02	B010100	B059999	CONNECTOR,RCPT,:76 CONTACT	80009	131-0767-02
J2	131-0767-08	B060000		CONNECTOR,RCPT,:PLUG-IN CKT BD,70 CONTACT	80009	131-0767-08
J3	131-0767-00	B010100	B059999	CONNECTOR,RCPT,:76 CONTACT	80009	131-0767-00
J3	131-0767-07	B060000		CONNECTOR,RCPT,:PLUG-IN CKT BD,70 CONTACT	80009	131-0767-07

Ckt No.	Tektronix Part No.	Serial/Model No. Eff	Dscont	Name & Description	Mfr Code	Mfr Part Number
J4	131-0767-00	B010100	B059999	CONNECTOR,RCPT,:76 CONTACT	80009	131-0767-00
J4	131-0767-07	B060000		CONNECTOR,RCPT,:PLUG-IN CKT BD,70 CONTACT	80009	131-0767-07
J20	131-1250-00	B010100	B091620X	CONNECTOR,RCPT,:60 CONTACT	95238	K60010060WA300
J2001	131-1003-00			CONNECTOR BODY,:CKT CD MT,3 PRONG	80009	131-1003-00
J2002	131-1003-00			CONNECTOR BODY,:CKT CD MT,3 PRONG	80009	131-1003-00
J2003	131-1003-00			CONNECTOR BODY,:CKT CD MT,3 PRONG	80009	131-1003-00
J2004	131-1003-00			CONNECTOR BODY,:CKT CD MT,3 PRONG	80009	131-1003-00
J2005	131-1003-00			CONNECTOR BODY,:CKT CD MT,3 PRONG	80009	131-1003-00
J2006	131-1003-00			CONNECTOR BODY,:CKT CD MT,3 PRONG	80009	131-1003-00
J2007	131-1003-00			CONNECTOR BODY,:CKT CD MT,3 PRONG	80009	131-1003-00
J2008	131-1003-00			CONNECTOR BODY,:CKT CD MT,3 PRONG	80009	131-1003-00
J2009	131-1003-00			CONNECTOR BODY,:CKT CD MT,3 PRONG	80009	131-1003-00
J2010	131-1003-00			CONNECTOR BODY,:CKT CD MT,3 PRONG	80009	131-1003-00
J2011	131-1003-00			CONNECTOR BODY,:CKT CD MT,3 PRONG	80009	131-1003-00
J2217	131-1003-00			CONNECTOR BODY,:CKT CD MT,3 PRONG	80009	131-1003-00
J2218	131-1003-00			CONNECTOR BODY,:CKT CD MT,3 PRONG	80009	131-1003-00
J2514	131-1003-00			CONNECTOR BODY,:CKT CD MT,3 PRONG	80009	131-1003-00
J3301	131-1003-00			CONNECTOR BODY,:CKT CD MT,3 PRONG	80009	131-1003-00
J3304	131-1003-00			CONNECTOR BODY,:CKT CD MT,3 PRONG	80009	131-1003-00
J3306	131-1003-00			CONNECTOR BODY,:CKT CD MT,3 PRONG	80009	131-1003-00
J3307	131-1003-00			CONNECTOR BODY,:CKT CD MT,3 PRONG	80009	131-1003-00
J3308	131-1003-00			CONNECTOR BODY,:CKT CD MT,3 PRONG	80009	131-1003-00
J3309	131-1003-00			CONNECTOR BODY,:CKT CD MT,3 PRONG	80009	131-1003-00
J3310	131-1003-00			CONNECTOR BODY,:CKT CD MT,3 PRONG	80009	131-1003-00
J3311	131-1003-00			CONNECTOR BODY,:CKT CD MT,3 PRONG	80009	131-1003-00
J3320	131-0955-00			CONNECTOR,RCPT,:BNC,FEMALE,W/HARDWARE	05091	31-279
J3321	131-0955-00			CONNECTOR,RCPT,:BNC,FEMALE,W/HARDWARE	05091	31-279
J3322	131-0955-00			CONNECTOR,RCPT,:BNC,FEMALE,W/HARDWARE	05091	31-279
J3323	131-0955-00			CONNECTOR,RCPT,:BNC,FEMALE,W/HARDWARE	05091	31-279
J3324	131-0955-00			CONNECTOR,RCPT,:BNC,FEMALE,W/HARDWARE	05091	31-279
J3401	131-1003-00			CONNECTOR BODY,:CKT CD MT,3 PRONG	80009	131-1003-00
J3402	131-1003-00			CONNECTOR BODY,:CKT CD MT,3 PRONG	80009	131-1003-00
J3403	131-1003-00			CONNECTOR BODY,:CKT CD MT,3 PRONG	80009	131-1003-00
J3404	131-1003-00			CONNECTOR BODY,:CKT CD MT,3 PRONG	80009	131-1003-00
J3405	131-1003-00			CONNECTOR BODY,:CKT CD MT,3 PRONG	80009	131-1003-00
J4105	131-1003-00			CONNECTOR BODY,:CKT CD MT,3 PRONG	80009	131-1003-00
J4114	131-1003-00			CONNECTOR BODY,:CKT CD MT,3 PRONG	80009	131-1003-00
J4120	131-1003-00			CONNECTOR BODY,:CKT CD MT,3 PRONG	80009	131-1003-00
J4140	131-1003-00			CONNECTOR BODY,:CKT CD MT,3 PRONG	80009	131-1003-00
J4212	131-1003-00			CONNECTOR BODY,:CKT CD MT,3 PRONG	80009	131-1003-00
J4213	131-1003-00			CONNECTOR BODY,:CKT CD MT,3 PRONG	80009	131-1003-00
J4220	131-1003-00			CONNECTOR BODY,:CKT CD MT,3 PRONG	80009	131-1003-00
J4240	131-1003-00			CONNECTOR BODY,:CKT CD MT,3 PRONG	80009	131-1003-00
J4304	131-1003-00			CONNECTOR BODY,:CKT CD MT,3 PRONG	80009	131-1003-00
J4315	131-1003-00			CONNECTOR BODY,:CKT CD MT,3 PRONG	80009	131-1003-00
J4316	131-1003-00			CONNECTOR BODY,:CKT CD MT,3 PRONG	80009	131-1003-00
J4405	131-1003-00			CONNECTOR BODY,:CKT CD MT,3 PRONG	80009	131-1003-00
J4417	131-1003-00			CONNECTOR BODY,:CKT CD MT,3 PRONG	80009	131-1003-00
J4418	131-1003-00			CONNECTOR BODY,:CKT CD MT,3 PRONG	80009	131-1003-00
J5030	131-0771-00			CONNECTOR,RCPT,:4 CONT,QUICK DISCONNECT	0000A	ROA-304NYL
J5033	131-0771-00			CONNECTOR,RCPT,:4 CONT,QUICK DISCONNECT	0000A	ROA-304NYL
L2006 (4)	276-0507-00			SHIELDING BEAD,:0.6UH	78488	57-0180-7D 500B

Replaceable Electrical Parts—7704A

Ckt No.	Tektronix Part No.	Serial/Model No. Eff	Dscont	Name & Description	Mfr Code	Mfr Part Number
L2016 (4)	276-0507-00			SHIELDING BEAD, :0.6UH	78488	57-0180-7D 500B
L2515	108-0245-00			COIL, RF: 3.9UH	80009	108-0245-00
L2519	108-0245-00			COIL, RF: 3.9UH	80009	108-0245-00
L2528	108-0245-00			COIL, RF: 3.9UH	80009	108-0245-00
L2560	108-0245-00			COIL, RF: 3.9UH	80009	108-0245-00
L2562	108-0245-00			COIL, RF: 3.9UH	80009	108-0245-00
L2563	108-0245-00			COIL, RF: 3.9UH	80009	108-0245-00
L2565	108-0245-00			COIL, RF: 3.9UH	80009	108-0245-00
L3029	108-0681-00			COIL, RF: 140UH	80009	108-0681-00
L3037	108-0678-00			COIL, RF: 1MH	80009	108-0678-00
L3168	108-0646-00	B010100	B139999	COIL, RF: 80UH	80009	108-0646-00
L3168	108-0681-00	B140000		COIL, RF: 140UH	80009	108-0681-00
L3171	108-0646-00			COIL, RF: 80UH	80009	108-0646-00
L3172	108-0680-00			COIL, RF: 27UH	80009	108-0680-00
L3174	108-0680-00			COIL, RF: 27UH	80009	108-0680-00
L3178	108-0679-00			COIL, RF: 12UH	80009	108-0679-00
L3181	108-0679-00			COIL, RF: 12UH	80009	108-0679-00
L3236	108-0337-00			COIL, RF: 25UH	80009	108-0337-00
L3482	108-0331-00			COIL, RF: 0.75UH	80009	108-0331-00
L4140	108-0065-00			COIL, RF: 700UH	80009	108-0065-00
L4252	108-0680-00			COIL, RF: 27UH	80009	108-0680-00
L4398	108-0245-00			COIL, RF: 3.9UH	80009	108-0245-00
L4399	108-0245-00			COIL, RF: 3.9UH	80009	108-0245-00
L4401	195-0048-00			LEAD, ELECTRICAL: 0.018 DIA X 0.75" MIN L	80009	195-0048-00
L4410	195-0048-00			LEAD, ELECTRICAL: 0.018 DIA X 0.75" MIN L	80009	195-0048-00
L4411	195-0048-00			LEAD, ELECTRICAL: 0.018 DIA X 0.75" MIN L	80009	195-0048-00
L5003	108-0544-00			COIL, TUBE DEFLE:	80009	108-0544-00
L5007	108-0546-00	B010100	B039999	COIL, TUBE DEFLE:	80009	108-0546-00
L5007	108-0605-00	B040000		COIL, TUBE DEFLE: Y AXIS ALIGNMENT	80009	108-0605-00
L5020	108-0686-00	B010100	B091620X	COIL, RF: 116UH	80009	108-0686-00
L5022	108-0686-00	B010100	B091620X	COIL, RF: 116UH	80009	108-0686-00
LR2245	108-0328-00			COIL, RF: 0.3UH	80009	108-0328-00
LR2523	108-0543-00			COIL, RF: FIXED, 1.1UH	80009	108-0543-00
LR2532	108-0543-00			COIL, RF: FIXED, 1.1UH	80009	108-0543-00
LR2536	108-0543-00			COIL, RF: FIXED, 1.1UH	80009	108-0543-00
LR2541	108-0543-00			COIL, RF: FIXED, 1.1UH	80009	108-0543-00
LR5010	108-0685-00			COIL, RF: 80NH	80009	108-0685-00
LR5011	108-0685-00			COIL, RF: 80NH	80009	108-0685-00
Q1001	151-0223-00			TRANSISTOR: SILICON, NPN	80009	151-0223-00
Q1003	151-0223-00			TRANSISTOR: SILICON, NPN	80009	151-0223-00
Q1011	151-0223-00			TRANSISTOR: SILICON, NPN	80009	151-0223-00
Q1021	151-0347-00			TRANSISTOR: SILICON, NPN	80009	151-0347-00
Q1023	151-0223-00			TRANSISTOR: SILICON, NPN	80009	151-0223-00
Q1025	151-0276-00			TRANSISTOR: SILICON, PNP	04713	2N5087
Q1027	151-0276-00			TRANSISTOR: SILICON, PNP	04713	2N5087
Q1031	151-0223-00			TRANSISTOR: SILICON, NPN	80009	151-0223-00
Q2030	151-0192-00			TRANSISTOR: SILICON, NPN, SEL FROM MPS6521	80009	151-0192-00
Q2070	151-0192-00			TRANSISTOR: SILICON, NPN, SEL FROM MPS6521	80009	151-0192-00
Q2080	151-0223-00			TRANSISTOR: SILICON, NPN	80009	151-0223-00
Q2090	151-0223-00			TRANSISTOR: SILICON, NPN	80009	151-0223-00
Q2203	151-0223-00			TRANSISTOR: SILICON, NPN	80009	151-0223-00
Q2205	151-0223-00			TRANSISTOR: SILICON, NPN	80009	151-0223-00

Ckt No.	Tektronix Part No.	Serial/Model No. Eff	Dscont	Name & Description	Mfr Code	Mfr Part Number
Q2209	151-0223-00			TRANSISTOR: SILICON, NPN	80009	151-0223-00
Q2241	151-0271-00			TRANSISTOR: SILICON, PNP	80009	151-0271-00
Q2242	151-0271-00			TRANSISTOR: SILICON, PNP	80009	151-0271-00
Q2255	151-0269-00			TRANSISTOR: SILICON, NPN, SEL FROM SE3005	80009	151-0269-00
Q2263	151-0269-00			TRANSISTOR: SILICON, NPN, SEL FROM SE3005	80009	151-0269-00
Q2331	151-0220-00			TRANSISTOR: SILICON, PNP	80009	151-0220-00
Q2337	151-0220-00			TRANSISTOR: SILICON, PNP	80009	151-0220-00
Q2414	151-0220-00			TRANSISTOR: SILICON, PNP	80009	151-0220-00
Q2416	151-0220-00			TRANSISTOR: SILICON, PNP	80009	151-0220-00
Q2434	151-0223-00	B010100	B039999	TRANSISTOR: SILICON, NPN	80009	151-0223-00
Q2434	151-0192-00	B040000		TRANSISTOR: SILICON, NPN, SEL FROM MPS6521	80009	151-0192-00
Q2436	151-0223-00	B010100	B039999	TRANSISTOR: SILICON, NPN	80009	151-0223-00
Q2436	151-0192-00	B040000		TRANSISTOR: SILICON, NPN, SEL FROM MPS6521	80009	151-0192-00
Q2444	151-0220-00			TRANSISTOR: SILICON, PNP	80009	151-0220-00
Q2446	151-0220-00			TRANSISTOR: SILICON, PNP	80009	151-0220-00
Q2533	151-0223-00			TRANSISTOR: SILICON, NPN	80009	151-0223-00
Q2550	151-0220-00			TRANSISTOR: SILICON, PNP	80009	151-0220-00
Q2553	151-0223-00			TRANSISTOR: SILICON, NPN	80009	151-0223-00
Q2556	151-0223-00			TRANSISTOR: SILICON, NPN	80009	151-0223-00
Q2569	151-0223-00			TRANSISTOR: SILICON, NPN	80009	151-0223-00
Q2576	151-0223-00			TRANSISTOR: SILICON, NPN	80009	151-0223-00
Q2577	151-0192-00			TRANSISTOR: SILICON, NPN, SEL FROM MPS6521	80009	151-0192-00
Q2579	151-0192-00			TRANSISTOR: SILICON, NPN, SEL FROM MPS6521	80009	151-0192-00
Q2596	151-0188-00			TRANSISTOR: SILICON, PNP	80009	151-0188-00
Q3034	151-0368-00			TRANSISTOR: SILICON, NPN	80009	151-0368-00
Q3047	151-0368-00			TRANSISTOR: SILICON, NPN	80009	151-0368-00
Q3048	151-0260-00			TRANSISTOR: SILICON, NPN	80009	151-0260-00
Q3052	151-0519-00	B010100	B194202	TRANSISTOR: SILICON, SCR	80009	151-0519-00
Q3052	151-0529-00	B194203		TRANSISTOR: SCR, 200V, 0.5A	04713	MCR206
Q3102	151-0302-00			TRANSISTOR: SILICON, NPN	04713	2N2222A
Q3104	151-0302-00			TRANSISTOR: SILICON, NPN	04713	2N2222A
Q3209A,B	151-0232-00			TRANSISTOR: SILICON, NPN, DUAL	80009	151-0232-00
Q3211	151-0350-00			TRANSISTOR: SILICON, PNP SILICON, PNP	80009	151-0350-00
Q3213	151-0347-00			TRANSISTOR: SILICON, NPN	80009	151-0347-00
Q3217	151-0190-01			TRANSISTOR: SILICON, NPN	80009	151-0190-01
Q3220	151-0136-00			TRANSISTOR: SILICON, NPN	02735	35495
Q3223	151-0349-00			TRANSISTOR: SILICON, NPN, SEL FROM MJE2801	80009	151-0349-00
Q3225	151-0350-00			TRANSISTOR: SILICON, PNP SILICON, PNP	80009	151-0350-00
Q3232A,B	151-0232-00			TRANSISTOR: SILICON, NPN, DUAL	80009	151-0232-00
Q3235A,B	151-0232-00			TRANSISTOR: SILICON, NPN, DUAL	80009	151-0232-00
Q3238	151-0347-00			TRANSISTOR: SILICON, NPN	80009	151-0347-00
Q3240	151-0260-00			TRANSISTOR: SILICON, NPN	80009	151-0260-00
Q3241	151-0349-00			TRANSISTOR: SILICON, NPN, SEL FROM MJE2801	80009	151-0349-00
Q3251A,B	151-0232-00			TRANSISTOR: SILICON, NPN, DUAL	80009	151-0232-00
Q3258	151-0192-00			TRANSISTOR: SILICON, NPN, SEL FROM MPS6521	80009	151-0192-00
Q3260	151-0260-00			TRANSISTOR: SILICON, NPN	80009	151-0260-00
Q3261	151-0349-00			TRANSISTOR: SILICON, NPN, SEL FROM MJE2801	80009	151-0349-00
Q3264A,B	151-0232-00			TRANSISTOR: SILICON, NPN, DUAL	80009	151-0232-00
Q3275A,B	151-0232-00			TRANSISTOR: SILICON, NPN, DUAL	80009	151-0232-00
Q3283A,B	151-0232-00			TRANSISTOR: SILICON, NPN, DUAL	80009	151-0232-00
Q3285	151-0216-00			TRANSISTOR: SILICON, PNP	80009	151-0216-00
Q3290	151-0260-00			TRANSISTOR: SILICON, NPN	80009	151-0260-00
Q3294	151-0349-00			TRANSISTOR: SILICON, NPN, SEL FROM MJE2801	80009	151-0349-00

Replaceable Electrical Parts—7704A

Ckt No.	Tektronix Part No.	Serial/Model No. Eff	Dscont	Name & Description	Mfr Code	Mfr Part Number
Q3306	151-0220-00			TRANSISTOR: SILICON, PNP	80009	151-0220-00
Q3308	151-0220-00			TRANSISTOR: SILICON, PNP	80009	151-0220-00
Q3312	151-0220-00			TRANSISTOR: SILICON, PNP	80009	151-0220-00
Q3315	151-0220-00			TRANSISTOR: SILICON, PNP	80009	151-0220-00
Q3321	151-0223-00			TRANSISTOR: SILICON, NPN	80009	151-0223-00
Q3323	151-0223-00			TRANSISTOR: SILICON, NPN	80009	151-0223-00
Q3330	151-0220-00			TRANSISTOR: SILICON, PNP	80009	151-0220-00
Q3351	151-0223-00			TRANSISTOR: SILICON, NPN	80009	151-0223-00
Q3353	151-0223-00			TRANSISTOR: SILICON, NPN	80009	151-0223-00
Q3361	151-0220-00			TRANSISTOR: SILICON, PNP	80009	151-0220-00
Q3367	151-0220-00			TRANSISTOR: SILICON, PNP	80009	151-0220-00
Q3373	151-0223-00			TRANSISTOR: SILICON, NPN	80009	151-0223-00
Q3406A, B	151-0232-00			TRANSISTOR: SILICON, NPN, DUAL	80009	151-0232-00
Q3411	151-0223-00			TRANSISTOR: SILICON, NPN	80009	151-0223-00
Q3414	151-0223-00			TRANSISTOR: SILICON, NPN	80009	151-0223-00
Q3416	151-0220-00			TRANSISTOR: SILICON, PNP	80009	151-0220-00
Q3419	151-0223-00			TRANSISTOR: SILICON, NPN	80009	151-0223-00
Q3427	151-0192-00			TRANSISTOR: SILICON, NPN, SEL FROM MPS6521	80009	151-0192-00
Q3442	151-0220-00			TRANSISTOR: SILICON, PNP	80009	151-0220-00
Q3445	151-0223-00			TRANSISTOR: SILICON, NPN	80009	151-0223-00
Q3486	151-0220-00			TRANSISTOR: SILICON, PNP	80009	151-0220-00
Q3489	151-0220-00			TRANSISTOR: SILICON, PNP	80009	151-0220-00
Q3493	151-0220-00			TRANSISTOR: SILICON, PNP	80009	151-0220-00
Q3499	151-0220-00			TRANSISTOR: SILICON, PNP	80009	151-0220-00
Q4105	151-0228-00			TRANSISTOR: SILICON, PNP, SEL FROM 2N4888	80009	151-0228-00
Q4115	151-0279-00			TRANSISTOR: SILICON, NPN	80009	151-0279-00
Q4135	151-0223-00			TRANSISTOR: SILICON, NPN	80009	151-0223-00
Q4145	151-0216-00			TRANSISTOR: SILICON, PNP	80009	151-0216-00
Q4151	151-0220-00			TRANSISTOR: SILICON, PNP	80009	151-0220-00
Q4159	151-0220-00			TRANSISTOR: SILICON, PNP	80009	151-0220-00
Q4163	151-0223-00			TRANSISTOR: SILICON, NPN	80009	151-0223-00
Q4175	151-0223-00			TRANSISTOR: SILICON, NPN	80009	151-0223-00
Q4177	151-0220-00			TRANSISTOR: SILICON, PNP	80009	151-0220-00
Q4183	151-0223-00			TRANSISTOR: SILICON, NPN	80009	151-0223-00
Q4185	151-0223-00			TRANSISTOR: SILICON, NPN	80009	151-0223-00
Q4193	151-0220-00	B010100	B039999	TRANSISTOR: SILICON, PNP	80009	151-0220-00
Q4193	151-0221-00	B040000		TRANSISTOR: SILICON, PNP	80009	151-0221-00
Q4197	151-0220-00	B010100	B039999	TRANSISTOR: SILICON, PNP	80009	151-0220-00
Q4197	151-0221-00	B040000		TRANSISTOR: SILICON, PNP	80009	151-0221-00
Q4250	151-0324-00			TRANSISTOR: SILICON, PNP	80009	151-0324-00
Q4254	151-0192-00			TRANSISTOR: SILICON, NPN, SEL FROM MPS6521	80009	151-0192-00
Q4304	151-0190-01			TRANSISTOR: SILICON, NPN	80009	151-0190-01
Q4321	151-0127-00			TRANSISTOR: SILICON, NPN	80009	151-0127-00
Q4325	151-0127-00			TRANSISTOR: SILICON, NPN	80009	151-0127-00
Q4331	151-0127-00			TRANSISTOR: SILICON, NPN	80009	151-0127-00
Q4335	151-0301-00			TRANSISTOR: SILICON, PNP	04713	2N2907A
Q4346	151-0190-01			TRANSISTOR: SILICON, NPN	80009	151-0190-01
Q4351	151-0220-00			TRANSISTOR: SILICON, PNP	80009	151-0220-00
Q4356	151-0274-00			TRANSISTOR: SILICON, NPN	80009	151-0274-00
Q4361	151-0220-00			TRANSISTOR: SILICON, PNP	80009	151-0220-00
Q4366	151-0274-00			TRANSISTOR: SILICON, NPN	80009	151-0274-00
Q4371	151-0270-00			TRANSISTOR: SILICON, PNP	80009	151-0270-00
Q4381	151-0127-00			TRANSISTOR: SILICON, NPN	80009	151-0127-00

Ckt No.	Tektronix Part No.	Serial/Model No. Eff	Dscont	Name & Description	Mfr Code	Mfr Part Number
Q4390	151-0127-00			TRANSISTOR:SILICON,NPN	80009	151-0127-00
Q4395	151-0270-00			TRANSISTOR:SILICON,PNP	80009	151-0270-00
Q4420	151-0188-00	XB120000		TRANSISTOR:SILICON,PNP	80009	151-0188-00
Q4470	151-0188-00		TRANSISTOR:SILICON,PNP	80009	151-0188-00	
Q4479	151-0190-00		TRANSISTOR:SILICON,NPN	80009	151-0190-00	
Q4485	151-0190-00		TRANSISTOR:SILICON,NPN	80009	151-0190-00	
Q32115	151-0350-00			TRANSISTOR:SILICON,PNP SILICON,PNP	80009	151-0350-00
Q32130A,	151-0232-00			TRANSISTOR:SILICON,NPN,DUAL	80009	151-0232-00
Q32130B						
Q32137	151-0347-00			TRANSISTOR:SILICON,NPN	80009	151-0347-00
Q32139	151-0349-00			TRANSISTOR:SILICON,NPN,SEL FROM MJE2801	80009	151-0349-00
Q32143	151-0136-00			TRANSISTOR:SILICON,NPN	02735	35495
Q41113	151-0221-00			TRANSISTOR:SILICON,PNP	80009	151-0221-00
Q41114	151-0208-00			TRANSISTOR:SILICON,PNP	80009	151-0208-00
Q41115	151-0124-00			TRANSISTOR:SILICON,NPN,SEL FROM 2N3501	80009	151-0124-00
Q41133	151-0223-00			TRANSISTOR:SILICON,NPN	80009	151-0223-00
Q41137	151-0274-00			TRANSISTOR:SILICON,NPN	80009	151-0274-00
Q41155	151-0274-00			TRANSISTOR:SILICON,NPN	80009	151-0274-00
R1001	311-1224-00			RES.,VAR,NONWIR:500 OHM,20%,0.50W	32997	3386F-T04-501
R1002	321-1234-02			RES.,FXD,FILM:2.71K OHM,0.5%,0.125W	91637	MFF1816D27100D
R1004	321-0364-00			RES.,FXD,FILM:60.4K OHM,1%,0.125W	91637	MFF1816G60401F
R1006	315-0472-00			RES.,FXD,CMPSN:4.7K OHM,5%,0.25W	01121	CB4725
R1007	321-0374-00			RES.,FXD,FILM:76.8K OHM,1%,0.125W	91637	MFF1816G76801F
R1009	315-0103-00			RES.,FXD,CMPSN:10K OHM,5%,0.25W	01121	CB1035
R1010	315-0103-00			RES.,FXD,CMPSN:10K OHM,5%,0.25W	01121	CB1035
R1012	315-0102-00			RES.,FXD,CMPSN:1K OHM,5%,0.25W	01121	CB1025
R1021	321-0315-00			RES.,FXD,FILM:18.7K OHM,1%,0.125W	91637	MFF1816G18701F
R1023	315-0153-00			RES.,FXD,CMPSN:15K OHM,5%,0.25W	01121	CB1535
R1025	321-0254-00			RES.,FXD,FILM:4.32K OHM,1%,0.125W	91637	MFF1816G43200F
R1026	321-0195-00			RES.,FXD,FILM:1.05K OHM,1%,0.125W	91637	MFF1816G10500F
R1027	321-1188-06			RES.,FXD,FILM:898 OHM,0.25%,0.125W	91637	MFF1816C898ROC
R1031	315-0102-00			RES.,FXD,CMPSN:1K OHM,5%,0.25W	01121	CB1025
R1033	315-0103-00			RES.,FXD,CMPSN:10K OHM,5%,0.25W	01121	CB1035
R1034	321-0281-00			RES.,FXD,FILM:8.25K OHM,1%,0.125W	91637	MFF1816G82500F
R1035	321-0820-06			RES.,FXD,FILM:42K OHM,0.25%,0.125W	91637	MFF1816C42001C
R1037	311-1228-00			RES.,VAR,NONWIR:10K OHM,20%,0.50W	32997	3386F-T04-103
R1038	315-0563-00			RES.,FXD,CMPSN:56K OHM,5%,0.25W	01121	CB5635
R1039	315-0393-00			RES.,FXD,CMPSN:39K OHM,5%,0.25W	01121	CB3935
R1041	301-0103-00			RES.,FXD,CMPSN:10K OHM,5%,0.50W	01121	EB1035
R1043	323-0761-07			RESISTOR:4.05K OHM, 0.50W, .1%	75042	CECT9-4051B
R1044	321-0815-07			RES.,FXD,FILM:4.1K OHM,0.1%,0.125W	91637	MFF1816C41000B
R1047	321-0812-07			RES.,FXD,FILM:455 OHM,0.1%,0.125W	91637	MFF1816C455ROB
R1048	321-0811-07			RES.,FXD,FILM:56.3 OHM,0.1%,0.125W	91637	MFF1816C56R30B
R1051	321-0813-07			RES.,FXD,FILM:495 OHM,0.1%,0.125W	91637	MFF1816C495ROB
R1052	321-0810-07			RES.,FXD,FILM:55 OHM,0.1%,0.125W	91637	MFF1816C55ROOB
R1057	321-0816-07			RES.,FXD,FILM:5K OHM,0.1%,0.125W	91637	MFF1816C50000B
R1058	321-1068-07			RES.,FXD,FILM:50.5 OHM,0.1%,0.125W	91637	MFF1816C50R50B
R1063	311-1301-00			RES.,VAR,NONWIR:50K OHM,20%,0.5W	01121	W-7917B
R1065	311-1301-00			RES.,VAR,NONWIR:50K OHM,20%,0.5W	01121	W-7917B
R1067	131-0566-00			LINK,TERM.CONNE:0.086 DIA X 2.375 INCH L	55210	L-2007-1
R1068	315-0153-00			RES.,FXD,CMPSN:15K OHM,5%,0.25W	01121	CB1535
R2001	315-0511-00	B010100	B149999X	RES.,FXD,CMPSN:510 OHM,5%,0.25W	01121	CB5115

Replaceable Electrical Parts—7704A

Ckt No.	Tektronix Part No.	Serial/Model No. Eff	Dscont/	Name & Description	Mfr Code	Mfr Part Number
R2003	315-0511-00	B010100	B149999X	RES., FXD, CMPSN:510 OHM, 5%, 0.25W	01121	CB5115
R2005	315-0511-00	B010100	B149999X	RES., FXD, CMPSN:510 OHM, 5%, 0.25W	01121	CB5115
R2006	315-0392-00	B010100	B010159	RES., FXD, CMPSN:3.9K OHM, 5%, 0.25W	01121	CB3925
R2006	315-0362-00	B010160		RES., FXD, CMPSN:3.6K OHM, 5%, 0.25W	01121	CB3625
R2007	315-0511-00	B010100	B149999X	RES., FXD, CMPSN:510 OHM, 5%, 0.25W	01121	CB5115
R2009	315-0243-00			RES., FXD, CMPSN:24K OHM, 5%, 0.25W	01121	CB2435
R2010	315-0510-00			RES., FXD, CMPSN:51 OHM, 5%, 0.25W	01121	CB5105
R2011	315-0510-00			RES., FXD, CMPSN:51 OHM, 5%, 0.25W	01121	CB5105
R2012	315-0510-00			RES., FXD, CMPSN:51 OHM, 5%, 0.25W	01121	CB5105
R2013	315-0510-00			RES., FXD, CMPSN:51 OHM, 5%, 0.25W	01121	CB5105
R2015	315-0510-00			RES., FXD, CMPSN:51 OHM, 5%, 0.25W	01121	CB5105
R2016	315-0510-00			RES., FXD, CMPSN:51 OHM, 5%, 0.25W	01121	CB5105
R2017	315-0132-00			RES., FXD, CMPSN:1.3K OHM, 5%, 0.25W	01121	CB1325
R2018	315-0202-00			RES., FXD, CMPSN:2K OHM, 5%, 0.25W	01121	CB2025
R2019	321-0231-00			RES., FXD, FILM:2.49K OHM, 1%, 0.125W	91637	MFF1816G24900F
R2020	315-0472-00			RES., FXD, CMPSN:4.7K OHM, 5%, 0.25W	01121	CB4725
R2022	315-0202-00			RES., FXD, CMPSN:2K OHM, 5%, 0.25W	01121	CB2025
R2023	315-0132-00			RES., FXD, CMPSN:1.3K OHM, 5%, 0.25W	01121	CB1325
R2025	315-0202-00			RES., FXD, CMPSN:2K OHM, 5%, 0.25W	01121	CB2025
R2026	315-0302-00			RES., FXD, CMPSN:3K OHM, 5%, 0.25W	01121	CB3025
R2027	315-0132-00			RES., FXD, CMPSN:1.3K OHM, 5%, 0.25W	01121	CB1325
R2029	321-0231-00			RES., FXD, FILM:2.49K OHM, 1%, 0.125W	91637	MFF1816G24900F
R2030	315-0512-00			RES., FXD, CMPSN:5.1K OHM, 5%, 0.25W	01121	CB5125
R2031	315-0102-00			RES., FXD, CMPSN:1K OHM, 5%, 0.25W	01121	CB1025
R2033	315-0751-00			RES., FXD, CMPSN:750 OHM, 5%, 0.25W	01121	CB7515
R2034	315-0751-00			RES., FXD, CMPSN:750 OHM, 5%, 0.25W	01121	CB7515
R2036	315-0102-00			RES., FXD, CMPSN:1K OHM, 5%, 0.25W	01121	CB1025
R2038	315-0751-00			RES., FXD, CMPSN:750 OHM, 5%, 0.25W	01121	CB7515
R2039	315-0751-00			RES., FXD, CMPSN:750 OHM, 5%, 0.25W	01121	CB7515
R2041	315-0102-00			RES., FXD, CMPSN:1K OHM, 5%, 0.25W	01121	CB1025
R2043	315-0751-00			RES., FXD, CMPSN:750 OHM, 5%, 0.25W	01121	CB7515
R2044	315-0751-00			RES., FXD, CMPSN:750 OHM, 5%, 0.25W	01121	CB7515
R2046	315-0102-00			RES., FXD, CMPSN:1K OHM, 5%, 0.25W	01121	CB1025
R2048	315-0751-00			RES., FXD, CMPSN:750 OHM, 5%, 0.25W	01121	CB7515
R2049	315-0751-00			RES., FXD, CMPSN:750 OHM, 5%, 0.25W	01121	CB7515
R2051	315-0242-00			RES., FXD, CMPSN:2.4K OHM, 5%, 0.25W	01121	CB2425
R2053	315-0102-00			RES., FXD, CMPSN:1K OHM, 5%, 0.25W	01121	CB1025
R2054	315-0511-00			RES., FXD, CMPSN:510 OHM, 5%, 0.25W	01121	CB5115
R2056	315-0511-00			RES., FXD, CMPSN:510 OHM, 5%, 0.25W	01121	CB5115
R2057	315-0511-00			RES., FXD, CMPSN:510 OHM, 5%, 0.25W	01121	CB5115
R2058	315-0513-00			RES., FXD, CMPSN:51K OHM, 5%, 0.25W	01121	CB5135
R2060	315-0133-00			RES., FXD, CMPSN:13K OHM, 5%, 0.25W	01121	CB1335
R2061	315-0133-00			RES., FXD, CMPSN:13K OHM, 5%, 0.25W	01121	CB1335
R2063	315-0753-00			RES., FXD, CMPSN:75K OHM, 5%, 0.25W	01121	CB7535
R2064	321-0308-00			RES., FXD, FILM:15.8K OHM, 1%, 0.125W	91637	MFF1816G15801F
R2066	315-0513-00			RES., FXD, CMPSN:51K OHM, 5%, 0.25W	01121	CB5135
R2067	321-0319-00			RES., FXD, FILM:20.5K OHM, 1%, 0.125W	91637	MFF1816G20501F
R2069	321-0335-00			RES., FXD, FILM:30.1K OHM, 1%, 0.125W	91637	MFF1816G30101F
R2070	315-0154-00			RES., FXD, CMPSN:150K OHM, 5%, 0.25W	01121	CB1545
R2071	321-0335-00			RES., FXD, FILM:30.1K OHM, 1%, 0.125W	91637	MFF1816G30101F
R2073	321-0344-00			RES., FXD, FILM:37.4K OHM, 1%, 0.125W	91637	MFF1816G37401F
R2074	321-0335-00			RES., FXD, FILM:30.1K OHM, 1%, 0.125W	91637	MFF1816G30101F
R2076	315-0513-00			RES., FXD, CMPSN:51K OHM, 5%, 0.25W	01121	CB5135

Ckt No.	Tektronix Part No.	Serial/Model No. Eff	Dscont	Name & Description	Mfr Code	Mfr Part Number
R2077	315-0154-00			RES.,FXD,CMPSN:150K OHM,5%,0.25W	01121	CB1545
R2078	321-0335-00			RES.,FXD,FILM:30.1K OHM,1%,0.125W	91637	MFF1816G30101F
R2079	321-0335-00			RES.,FXD,FILM:30.1K OHM,1%,0.125W	91637	MFF1816G30101F
R2080	315-0510-00			RES.,FXD,CMPSN:51 OHM,5%,0.25W	01121	CB5105
R2081	315-0103-00			RES.,FXD,CMPSN:10K OHM,5%,0.25W	01121	CB1035
R2083	315-0562-00			RES.,FXD,CMPSN:5.6K OHM,5%,0.25W	01121	CB5625
R2084	315-0302-00			RES.,FXD,CMPSN:3K OHM,5%,0.25W	01121	CB3025
R2085	315-0513-00			RES.,FXD,CMPSN:51K OHM,5%,0.25W	01121	CB5135
R2087	321-0260-00			RES.,FXD,FILM:4.99K OHM,1%,0.125W	91637	MFF1816G49900F
R2088	321-0260-00			RES.,FXD,FILM:4.99K OHM,1%,0.125W	91637	MFF1816G49900F
R2090	315-0510-00			RES.,FXD,CMPSN:51 OHM,5%,0.25W	01121	CB5105
R2091	315-0103-00			RES.,FXD,CMPSN:10K OHM,5%,0.25W	01121	CB1035
R2092	315-0241-00			RES.,FXD,CMPSN:240 OHM,5%,0.25W	01121	CB2415
R2093	315-0562-00			RES.,FXD,CMPSN:5.6K OHM,5%,0.25W	01121	CB5625
R2094	315-0302-00			RES.,FXD,CMPSN:3K OHM,5%,0.25W	01121	CB3025
R2095	315-0513-00			RES.,FXD,CMPSN:51K OHM,5%,0.25W	01121	CB5135
R2097	321-0260-00			RES.,FXD,FILM:4.99K OHM,1%,0.125W	91637	MFF1816G49900F
R2098	321-0260-00			RES.,FXD,FILM:4.99K OHM,1%,0.125W	91637	MFF1816G49900F
R2201	321-0068-00			RES.,FXD,FILM:49.9 OHM,1%,0.125W	91637	MFF1816G49R90F
R2202	321-0068-00			RES.,FXD,FILM:49.9 OHM,1%,0.125W	91637	MFF1816G49R90F
R2203	315-0153-00			RES.,FXD,CMPSN:15K OHM,5%,0.25W	01121	CB1535
R2205	315-0102-00			RES.,FXD,CMPSN:1K OHM,5%,0.25W	01121	CB1025
R2207	315-0511-00			RES.,FXD,CMPSN:510 OHM,5%,0.25W	01121	CB5115
R2208	315-0242-00			RES.,FXD,CMPSN:2.4K OHM,5%,0.25W	01121	CB2425
R2209	315-0511-00			RES.,FXD,CMPSN:510 OHM,5%,0.25W	01121	CB5115
R2210	321-0741-02			RES.,FXD,FILM:40.9 OHM,0.5%,0.125W	91637	MFF1816D40R90D
R2211	321-0741-02			RES.,FXD,FILM:40.9 OHM,0.5%,0.125W	91637	MFF1816D40R90D
R2212	321-0217-00			RES.,FXD,FILM:1.78K OHM,1%,0.125W	91637	MFF1816G17800F
R2213	321-0741-02			RES.,FXD,FILM:40.9 OHM,0.5%,0.125W	91637	MFF1816D40R90D
R2214	321-0741-02			RES.,FXD,FILM:40.9 OHM,0.5%,0.125W	91637	MFF1816D40R90D
R2215	321-0217-00			RES.,FXD,FILM:1.78K OHM,1%,0.125W	91637	MFF1816G17800F
R2216	315-0152-00			RES.,FXD,CMPSN:1.5K OHM,5%,0.25W	01121	CB1525
R2217	315-0152-00			RES.,FXD,CMPSN:1.5K OHM,5%,0.25W	01121	CB1525
R2221	317-0680-00			RES.,FXD,CMPSN:68 OHM,5%,0.125W	01121	BB6805
R2222	311-1007-00			RES.,VAR,NONWIR:20 OHM,20%,0.50W	73138	82-38-0
R2223	323-0144-00			RES.,FXD,FILM:309 OHM,1%,0.50W	75042	CECT0-3090F
R2224	317-0680-00			RES.,FXD,CMPSN:68 OHM,5%,0.125W	01121	BB6805
R2225	323-0143-00			RES.,FXD,FILM:301 OHM,1%,0.50W	75042	CECT0-3010F
R2226	321-1068-01			RES.,FXD,FILM:50.5 OHM,0.5%,0.125W	91637	MFF1816G50R50D
R2227	321-1068-01			RES.,FXD,FILM:50.5 OHM,0.5%,0.125W	91637	MFF1816G50R50D
R2228	321-1068-01			RES.,FXD,FILM:50.5 OHM,0.5%,0.125W	91637	MFF1816G50R50D
R2229	321-1068-01			RES.,FXD,FILM:50.5 OHM,0.5%,0.125W	91637	MFF1816G50R50D
R2230	317-0101-00	B010100	B049999	RES.,FXD,CMPSN:100 OHM,5%,0.125W	01121	BB1015
R2230	317-0510-00	B050000		RES.,FXD,CMPSN:51 OHM,5%,0.125W	01121	BB5105
R2231	321-0636-00			RES.,FXD,FILM:100 OHM,0.5%,0.125W	91637	MFF1816D100R0D
R2233	317-0101-00	B010100	B049999	RES.,FXD,CMPSN:100 OHM,5%,0.125W	01121	BB1015
R2233	317-0510-00	B050000		RES.,FXD,CMPSN:51 OHM,5%,0.125W	01121	BB5105
R2234	315-0302-00	B010100	B079999	RES.,FXD,CMPSN:3K OHM,5%,0.25W	01121	CB3025
R2234	311-0634-00	B080000		RES.,VAR,NONWIR:500 OHM,10%,0.50W	73138	82-31-0
R2235	315-0302-00	B010100	B079999	RES.,FXD,CMPSN:3K OHM,5%,0.25W	01121	CB3025
R2235	317-0240-00	B080000		RES.,FXD,CMPSN:24 OHM,5%,0.125W	01121	BB2405
R2237	321-0219-02			RES.,FXD,FILM:1.87K OHM,0.5%,0.125W	75042	CEAT2-1871D
R2239	321-0219-02			RES.,FXD,FILM:1.87K OHM,0.5%,0.125W	75042	CEAT2-1871D

Replaceable Electrical Parts—7704A

Ckt No.	Tektronix Part No.	Serial/Model No. Eff	Dscont	Name & Description	Mfr Code	Mfr Part Number
R2241	317-0270-00			RES.,FXD,CMPSN:27 OHM,5%,0.125W	01121	BB2705
R2242	317-0270-00			RES.,FXD,CMPSN:27 OHM,5%,0.125W	01121	BB2705
R2243	321-0173-00			RES.,FXD,FILM:619 OHM,1%,0.125W	91637	MFF1816G619R0F
R2244	315-0152-00			RES.,FXD,CMPSN:1.5K OHM,5%,0.25W	01121	CB1525
R2247	311-0605-00			RES.,VAR,NONWIR:200 OHM,10%,0.50W	80740	62-54-3
R2250	315-0300-00			RES.,FXD,CMPSN:30 OHM,5%,0.25W	01121	CB3005
R2251	322-0237-00			RES.,FXD,FILM:2.87K OHM,1%,0.25W	75042	CEBT0-2871F
R2253	321-0126-00			RES.,FXD,FILM:200 OHM,1%,0.125W	91637	MFF1816G200R0F
R2255	315-0102-00			RES.,FXD,CMPSN:1K OHM,5%,0.25W	01121	CB1025
R2259	321-0067-00			RES.,FXD,FILM:48.7 OHM,1%,0.125W	91637	MFF1816G48R70F
R2260	315-0300-00			RES.,FXD,CMPSN:30 OHM,5%,0.25W	01121	CB3005
R2261	322-0237-00			RES.,FXD,FILM:2.87K OHM,1%,0.25W	75042	CEBT0-2871F
R2263	321-0126-00			RES.,FXD,FILM:200 OHM,1%,0.125W	91637	MFF1816G200R0F
R2265	315-0102-00			RES.,FXD,CMPSN:1K OHM,5%,0.25W	01121	CB1025
R2267	321-0067-00			RES.,FXD,FILM:48.7 OHM,1%,0.125W	91637	MFF1816G48R70F
R2275	315-0750-00			RES.,FXD,CMPSN:75 OHM,5%,0.25W	01121	CB7505
R2277	315-0131-00			RES.,FXD,CMPSN:130 OHM,5%,0.25W	01121	CB1315
R2279	317-0103-00			RES.,FXD,CMPSN:10K OHM,5%,0.125W	01121	BB1035
R2280	317-0101-00	B010100	B049999	RES.,FXD,CMPSN:100 OHM,5%,0.125W	01121	BB1015
R2280	317-0510-00	B050000		RES.,FXD,CMPSN:51 OHM,5%,0.125W	01121	BB5105
R2281	321-0636-00			RES.,FXD,FILM:100 OHM,0.5%,0.125W	91637	MFF1816D100R0D
R2283	317-0101-00	B010100	B049999	RES.,FXD,CMPSN:100 OHM,5%,0.125W	01121	BB1015
R2283	317-0510-00	B050000		RES.,FXD,CMPSN:51 OHM,5%,0.125W	01121	BB5105
R2284	315-0302-00	B010100	B079999	RES.,FXD,CMPSN:3K OHM,5%,0.25W	01121	CB3025
R2284	311-0634-00	B080000		RES.,VAR,NONWIR:500 OHM,10%,0.50W	73138	82-31-0
R2285	315-0302-00	B010100	B079999	RES.,FXD,CMPSN:3K OHM,5%,0.25W	01121	CB3025
R2285	317-0240-00	B080000		RES.,FXD,CMPSN:24 OHM,5%,0.125W	01121	BB2405
R2287	321-0219-02			RES.,FXD,FILM:1.87K OHM,0.5%,0.125W	75042	CEAT2-1871D
R2289	321-0219-02			RES.,FXD,FILM:1.87K OHM,0.5%,0.125W	75042	CEAT2-1871D
R2301	321-1068-01			RES.,FXD,FILM:50.5 OHM,0.5%,0.125W	91637	MFF1816G50R50D
R2302	321-1068-01			RES.,FXD,FILM:50.5 OHM,0.5%,0.125W	91637	MFF1816G50R50D
R2303	321-1068-01			RES.,FXD,FILM:50.5 OHM,0.5%,0.125W	91637	MFF1816G50R50D
R2304	321-1068-01			RES.,FXD,FILM:50.5 OHM,0.5%,0.125W	91637	MFF1816G50R50D
R2311	321-0085-00			RES.,FXD,FILM:75 OHM,1%,0.125W	91637	MFF1816G75R00F
R2313	311-1007-00			RES.,VAR,NONWIR:20 OHM,20%,0.50W	73138	82-38-0
R2315	315-0512-00	B010100	B079999X	RES.,FXD,CMPSN:5.1K OHM,5%,0.25W	01121	CB5125
R2317	321-0217-00			RES.,FXD,FILM:1.78K OHM,1%,0.125W	91637	MFF1816G17800F
R2319	321-0217-00			RES.,FXD,FILM:1.78K OHM,1%,0.125W	91637	MFF1816G17800F
R2320	321-0218-00			RES.,FXD,FILM:1.82K OHM,1%,0.125W	91637	MFF1816G18200F
R2321	321-0085-00			RES.,FXD,FILM:75 OHM,1%,0.125W	91637	MFF1816G75R00F
R2323	311-1007-00			RES.,VAR,NONWIR:20 OHM,20%,0.50W	73138	82-38-0
R2325	315-0512-00	B010100	B079999X	RES.,FXD,CMPSN:5.1K OHM,5%,0.25W	01121	CB5125
R2327	321-0217-00			RES.,FXD,FILM:1.78K OHM,1%,0.125W	91637	MFF1816G17800F
R2329	321-0217-00			RES.,FXD,FILM:1.78K OHM,1%,0.125W	91637	MFF1816G17800F
R2330	315-0431-00			RES.,FXD,CMPSN:430 OHM,5%,0.25W	01121	CB4315
R2331	315-0200-00			RES.,FXD,CMPSN:20 OHM,5%,0.25W	01121	CB2005
R2333	323-0155-00	B010100	B049999	RES.,FXD,FILM:402 OHM,1%,0.50W	75042	CECT0-4020F
R2333	323-0149-00	B050000		RES.,FXD,FILM:348 OHM,1%,0.50W	75042	CECT0-3480F
R2335	323-0155-00	B010100	B049999	RES.,FXD,FILM:402 OHM,1%,0.50W	75042	CECT0-4020F
R2335	323-0149-00	B050000		RES.,FXD,FILM:348 OHM,1%,0.50W	75042	CECT0-3480F
R2337	315-0200-00	B010100	B173849	RES.,FXD,CMPSN:20 OHM,5%,0.25W	01121	CB2005
R2341	315-0241-00			RES.,FXD,CMPSN:240 OHM,5%,0.25W	01121	CB2415
R2343	322-0219-00	B010100	B049999	RES.,FXD,FILM:1.87K OHM,1%,0.25W	75042	CEBT0-1871F

Ckt No.	Tektronix Part No.	Serial/Model No. Eff	Dscont	Name & Description	Mfr Code	Mfr Part Number
R2343	321-0210-00	B050000		RES.,FXD,FILM:1.5K OHM,1%,0.125W	91637	MFF1816G15000F
R2345	322-0219-00	B010100	B049999	RES.,FXD,FILM:1.87K OHM,1%,0.25W	75042	CEBT0-1871F
R2345	321-0210-00	B050000		RES.,FXD,FILM:1.5K OHM,1%,0.125W	91637	MFF1816G15000F
R2347	315-0241-00			RES.,FXD,CMPSN:240 OHM,5%,0.25W	01121	CB2415
R2401	321-1068-01			RES.,FXD,FILM:50.5 OHM,0.5%,0.125W	91637	MFF1816G50R50D
R2402	321-1068-01			RES.,FXD,FILM:50.5 OHM,0.5%,0.125W	91637	MFF1816G50R50D
R2403	321-0741-02	B010100	B039999	RES.,FXD,FILM:40.9 OHM,0.5%,0.125W	91637	MFF1816D40R90D
R2403	321-0058-00	B040000		RES.,FXD,FILM:39.2 OHM,1%,0.125W	91637	MFF1816G39R20F
R2404	322-0184-00			RES.,FXD,FILM:806 OHM,1%,0.25W	75042	CEBT0-8060F
R2405	321-0741-02	B010100	B039999	RES.,FXD,FILM:40.9 OHM,0.5%,0.125W	91637	MFF1816D40R90D
R2405	321-0058-00	B040000		RES.,FXD,FILM:39.2 OHM,1%,0.125W	91637	MFF1816G39R20F
R2406	321-0741-02	B010100	B039999	RES.,FXD,FILM:40.9 OHM,0.5%,0.125W	91637	MFF1816D40R90D
R2406	321-0058-00	B040000		RES.,FXD,FILM:39.2 OHM,1%,0.125W	91637	MFF1816G39R20F
R2407	321-0741-02	B010100	B039999	RES.,FXD,FILM:40.9 OHM,0.5%,0.125W	91637	MFF1816D40R90D
R2407	321-0058-00	B040000		RES.,FXD,FILM:39.2 OHM,1%,0.125W	91637	MFF1816G39R20F
R2408	322-0184-00			RES.,FXD,FILM:806 OHM,1%,0.25W	75042	CEBT0-8060F
R2409	321-0189-00			RES.,FXD,FILM:909 OHM,1%,0.125W	91637	MFF1816G909ROF
R2411	315-0560-00	B010100	B039999	RES.,FXD,CMPSN:56 OHM,5%,0.25W	01121	CB5605
R2411	315-0430-00	B040000		RES.,FXD,CMPSN:43 OHM,5%,0.25W	01121	CB4305
R2412	315-0560-00	B010100	B039999	RES.,FXD,CMPSN:56 OHM,5%,0.25W	01121	CB5605
R2412	315-0430-00	B040000		RES.,FXD,CMPSN:43 OHM,5%,0.25W	01121	CB4305
R2413	323-0155-00			RES.,FXD,FILM:402 OHM,1%,0.50W	75042	CECT0-4020F
R2414	323-0155-00			RES.,FXD,FILM:402 OHM,1%,0.50W	75042	CECT0-4020F
R2416	315-0331-00			RES.,FXD,CMPSN:330 OHM,5%,0.25W	01121	CB3315
R2418	321-0214-00			RES.,FXD,FILM:1.65K OHM,1%,0.125W	91637	MFF1816G16500F
R2419	321-0214-00			RES.,FXD,FILM:1.65K OHM,1%,0.125W	91637	MFF1816G16500F
R2421	321-1068-01			RES.,FXD,FILM:50.5 OHM,0.5%,0.125W	91637	MFF1816G50R50D
R2422	321-1068-01			RES.,FXD,FILM:50.5 OHM,0.5%,0.125W	91637	MFF1816G50R50D
R2423	321-0741-02			RES.,FXD,FILM:40.9 OHM,0.5%,0.125W	91637	MFF1816D40R90D
R2424	322-0184-00			RES.,FXD,FILM:806 OHM,1%,0.25W	75042	CEBT0-8060F
R2425	321-0741-02			RES.,FXD,FILM:40.9 OHM,0.5%,0.125W	91637	MFF1816D40R90D
R2427	321-0741-02			RES.,FXD,FILM:40.9 OHM,0.5%,0.125W	91637	MFF1816D40R90D
R2428	322-0184-00			RES.,FXD,FILM:806 OHM,1%,0.25W	75042	CEBT0-8060F
R2429	321-0741-02			RES.,FXD,FILM:40.9 OHM,0.5%,0.125W	91637	MFF1816D40R90D
R2431	321-0053-00			RES.,FXD,FILM:34.8 OHM,1%,0.125W	91637	MFF1816G34R80F
R2432	321-0053-00			RES.,FXD,FILM:34.8 OHM,1%,0.125W	91637	MFF1816G34R80F
R2435	315-0103-00			RES.,FXD,CMPSN:10K OHM,5%,0.25W	01121	CB1035
R2436	315-0331-00			RES.,FXD,CMPSN:330 OHM,5%,0.25W	01121	CB3315
R2437	321-0129-00			RES.,FXD,FILM:215 OHM,1%,0.125W	91637	MFF1816G215ROF
R2438	321-0129-00			RES.,FXD,FILM:215 OHM,1%,0.125W	91637	MFF1816G215ROF
R2439	321-0082-00			RES.,FXD,FILM:69.8 OHM,1%,0.125W	91637	MFF1816G69R80F
R2440	321-0069-00			RES.,FXD,FILM:51.1 OHM,1%,0.125W	91637	MFF1816G51R10F
R2441	321-0069-00			RES.,FXD,FILM:51.1 OHM,1%,0.125W	91637	MFF1816G51R10F
R2443	321-0214-00			RES.,FXD,FILM:1.65K OHM,1%,0.125W	91637	MFF1816G16500F
R2444	315-0101-00			RES.,FXD,CMPSN:100 OHM,5%,0.25W	01121	CB1015
R2445	315-0561-00			RES.,FXD,CMPSN:560 OHM,5%,0.25W	01121	CB5615
R2446	321-0050-00			RES.,FXD,FILM:32.4 OHM,1%,0.125W	91637	MFF1816G32R40F
R2447	321-0050-00			RES.,FXD,FILM:32.4 OHM,1%,0.125W	91637	MFF1816G32R40F
R2448	315-0101-00			RES.,FXD,CMPSN:100 OHM,5%,0.25W	01121	CB1015
R2449	321-0214-00			RES.,FXD,FILM:1.65K OHM,1%,0.125W	91637	MFF1816G16500F
R2451	301-0220-00			RES.,FXD,CMPSN:22 OHM,5%,0.50W	01121	EB2205
R2501	315-0332-00			RES.,FXD,CMPSN:3.3K OHM,5%,0.25W	01121	CB3325
R2502	315-0202-00			RES.,FXD,CMPSN:2K OHM,5%,0.25W	01121	CB2025

Replaceable Electrical Parts—7704A

Ckt No.	Tektronix Part No.	Serial/Model No. Eff	Dscont	Name & Description	Mfr Code	Mfr Part Number
R2503	315-0223-00			RES., FXD, CMPSN: 22K OHM, 5%, 0.25W	01121	CB2235
R2504	321-0193-00			RES., FXD, FILM: 1K OHM, 1%, 0.125W	91637	MFF1816G10000F
R2505	315-0223-00			RES., FXD, CMPSN: 22K OHM, 5%, 0.25W	01121	CB2235
R2506	321-0193-00			RES., FXD, FILM: 1K OHM, 1%, 0.125W	91637	MFF1816G10000F
R2510	315-0301-00	B010100	B079999	RES., FXD, CMPSN: 300 OHM, 5%, 0.25W	01121	CB3015
R2510	315-0471-00	B080000	B139999	RES., FXD, CMPSN: 470 OHM, 5%, 0.25W	01121	CB4715
R2510	315-0621-00	B140000		RES., FXD, CMPSN: 620 OHM, 5%, 0.25W	01121	CB6215
R2511	315-0302-00	B010100	B010139	RES., FXD, CMPSN: 3K OHM, 5%, 0.25W	01121	CB3025
R2511	315-0392-00	B010140	B139999	RES., FXD, CMPSN: 3.9K OHM, 5%, 0.25W	01121	CB3925
R2511	315-0472-00	B140000		RES., FXD, CMPSN: 4.7K OHM, 5%, 0.25W	01121	CB4725
R2512	315-0682-00			RES., FXD, CMPSN: 6.8K OHM, 5%, 0.25W	01121	CB6825
R2513	315-0912-00			RES., FXD, CMPSN: 9.1K OHM, 5%, 0.25W	01121	CB9125
R2514	315-0512-00			RES., FXD, CMPSN: 5.1K OHM, 5%, 0.25W	01121	CB5125
R2515	315-0101-00			RES., FXD, CMPSN: 100 OHM, 5%, 0.25W	01121	CB1015
R2517	321-0244-00			RES., FXD, FILM: 3.4K OHM, 1%, 0.125W	91637	MFF1816G34000F
R2518	315-0332-00			RES., FXD, CMPSN: 3.3K OHM, 5%, 0.25W	01121	CB3325
R2519	315-0271-00			RES., FXD, CMPSN: 270 OHM, 5%, 0.25W	01121	CB2715
R2520	315-0512-00			RES., FXD, CMPSN: 5.1K OHM, 5%, 0.25W	01121	CB5125
R2521	315-0101-00			RES., FXD, CMPSN: 100 OHM, 5%, 0.25W	01121	CB1015
R2524	315-0242-00			RES., FXD, CMPSN: 2.4K OHM, 5%, 0.25W	01121	CB2425
R2525	315-0512-00			RES., FXD, CMPSN: 5.1K OHM, 5%, 0.25W	01121	CB5125
R2526	315-0512-00			RES., FXD, CMPSN: 5.1K OHM, 5%, 0.25W	01121	CB5125
R2527	315-0332-00			RES., FXD, CMPSN: 3.3K OHM, 5%, 0.25W	01121	CB3325
R2528	315-0271-00			RES., FXD, CMPSN: 270 OHM, 5%, 0.25W	01121	CB2715
R2529	315-0332-00	B010100	B132604	RES., FXD, CMPSN: 3.3K OHM, 5%, 0.25W	01121	CB3325
R2529	315-0182-00	B132605		RES., FXD, CMPSN: 1.8K OHM, 5%, 0.25W	01121	CB1825
R2530	315-0222-00			RES., FXD, CMPSN: 2.2K OHM, 5%, 0.25W	01121	CB2225
R2531	315-0332-00			RES., FXD, CMPSN: 3.3K OHM, 5%, 0.25W	01121	CB3325
R2533	315-0102-00			RES., FXD, CMPSN: 1K OHM, 5%, 0.25W	01121	CB1025
R2534	315-0222-00			RES., FXD, CMPSN: 2.2K OHM, 5%, 0.25W	01121	CB2225
R2535	315-0222-00			RES., FXD, CMPSN: 2.2K OHM, 5%, 0.25W	01121	CB2225
R2538	315-0332-00			RES., FXD, CMPSN: 3.3K OHM, 5%, 0.25W	01121	CB3325
R2540	315-0222-00			RES., FXD, CMPSN: 2.2K OHM, 5%, 0.25W	01121	CB2225
R2542	315-0332-00			RES., FXD, CMPSN: 3.3K OHM, 5%, 0.25W	01121	CB3325
R2550	315-0103-00			RES., FXD, CMPSN: 10K OHM, 5%, 0.25W	01121	CB1035
R2551	315-0202-00			RES., FXD, CMPSN: 2K OHM, 5%, 0.25W	01121	CB2025
R2552	315-0302-00			RES., FXD, CMPSN: 3K OHM, 5%, 0.25W	01121	CB3025
R2553	315-0303-00			RES., FXD, CMPSN: 30K OHM, 5%, 0.25W	01121	CB3035
R2555	315-0222-00			RES., FXD, CMPSN: 2.2K OHM, 5%, 0.25W	01121	CB2225
R2556	315-0332-00			RES., FXD, CMPSN: 3.3K OHM, 5%, 0.25W	01121	CB3325
R2558	315-0301-00			RES., FXD, CMPSN: 300 OHM, 5%, 0.25W	01121	CB3015
R2559	315-0102-00			RES., FXD, CMPSN: 1K OHM, 5%, 0.25W	01121	CB1025
R2565	315-0100-00	B010100	B109999X	RES., FXD, CMPSN: 10 OHM, 5%, 0.25W	01121	CB1005
R2569	315-0512-00			RES., FXD, CMPSN: 5.1K OHM, 5%, 0.25W	01121	CB5125
R2570	315-0201-00			RES., FXD, CMPSN: 200 OHM, 5%, 0.25W	01121	CB2015
R2571	321-0298-00			RES., FXD, FILM: 12.4K OHM, 1%, 0.125W	91637	MFF1816G12401F
R2572	321-0298-00			RES., FXD, FILM: 12.4K OHM, 1%, 0.125W	91637	MFF1816G12401F
R2573	315-0201-00			RES., FXD, CMPSN: 200 OHM, 5%, 0.25W	01121	CB2015
R2575	315-0153-00			RES., FXD, CMPSN: 15K OHM, 5%, 0.25W	01121	CB1535
R2577	321-0254-00			RES., FXD, FILM: 4.32K OHM, 1%, 0.125W	91637	MFF1816G43200F
R2579	321-0254-00			RES., FXD, FILM: 4.32K OHM, 1%, 0.125W	91637	MFF1816G43200F
R2580	315-0201-00			RES., FXD, CMPSN: 200 OHM, 5%, 0.25W	01121	CB2015
R2581	321-0201-00	B010100	B149999	RES., FXD, FILM: 1.21K OHM, 1%, 0.125W	91637	MFF1816G12100F

Ckt No.	Tektronix Part No.	Serial/Model No. Eff	Discont	Name & Description	Mfr Code	Mfr Part Number
R2581	321-0199-00	B150000		RES.,FXD,FILM:1.15K OHM,1%,0.125W	91637	MFF1816G11500F
R2582	315-0622-00			RES.,FXD,CMPSN:6.2K OHM,5%,0.25W	01121	CB6225
R2583	315-0622-00			RES.,FXD,CMPSN:6.2K OHM,5%,0.25W	01121	CB6225
R2586	315-0332-00			RES.,FXD,CMPSN:3.3K OHM,5%,0.25W	01121	CB3325
R2587	315-0392-00	B010100	B079999	RES.,FXD,CMPSN:3.9K OHM,5%,0.25W	01121	CB3925
R2587	321-0253-00	B080000	B194311	RES.,FXD,FILM:4.22K OHM,1%,0.125W	91637	MFF1816G42200F
R2587	321-0234-00	B194312		RES.,FXD,FILM:2.67K OHM,1%,0.125W	91637	MFF1816G26700F
R2588	315-0392-00	B010100	B079999	RES.,FXD,CMPSN:3.9K OHM,5%,0.25W	01121	CB3925
R2588	321-0253-00	B080000	B194311	RES.,FXD,FILM:4.22K OHM,1%,0.125W	91637	MFF1816G42200F
R2588	321-0235-00	B194312		RES.,FXD,FILM:2.74K OHM,1%,0.125W	91637	MFF1816G27400F
R2590	321-0279-00	B010100	B194311X	RES.,FXD,FILM:7.87K OHM,1%,0.125W	91637	MFF1816G78700F
R2591	321-0275-00	B010100	B194311X	RES.,FXD,FILM:7.15K OHM,1%,0.125W	91637	MFF1816G71500F
R2594	315-0683-00			RES.,FXD,CMPSN:68K OHM,5%,0.25W	01121	CB6835
R2595	315-0751-00			RES.,FXD,CMPSN:750 OHM,5%,0.25W	01121	CB7515
R2596	315-0103-00			RES.,FXD,CMPSN:10K OHM,5%,0.25W	01121	CB1035
R2597	315-0103-00			RES.,FXD,CMPSN:10K OHM,5%,0.25W	01121	CB1035
R2598	321-0247-00	B010100	B149999	RES.,FXD,FILM:3.65K OHM,1%,0.125W	91637	MFF1816G36500F
R2598	321-0243-00	B150000		RES.,FXD,FILM:3.32K OHM,1%,0.125W	91637	MFF1816G33200F
R2599	315-0151-00			RES.,FXD,CMPSN:150 OHM,5%,0.25W	01121	CB1515
R3005	304-0270-00			RES.,FXD,CMPSN:27 OHM,10%,1W	01121	GB2701
R3008	304-0473-00			RES.,FXD,CMPSN:47K OHM,10%,1W	01121	GB4731
R3010	303-0304-00			RES.,FXD,CMPSN:300K OHM,5%,1W	01121	GB3045
R3013	304-0473-00			RES.,FXD,CMPSN:47K OHM,10%,1W	01121	GB4731
R3019	302-0565-00			RES.,FXD,CMPSN:5.6M OHM,10%,0.50W	01121	EB5651
R3021	304-0154-00			RES.,FXD,CMPSN:150K OHM,10%,1W	01121	GB1541
R3025	316-0471-00			RES.,FXD,CMPSN:470 OHM,10%,0.25W	01121	CB4711
R3031	307-0057-00			RES.,FXD,CMPSN:5.1 OHM,5%,0.50W	01121	EB51G5
R3032	316-0220-00			RES.,FXD,CMPSN:22 OHM,10%,0.25W	01121	CB2201
R3034	316-0684-00			RES.,FXD,CMPSN:680K OHM,10%,0.25W	01121	CB6841
R3039	316-0103-00			RES.,FXD,CMPSN:10K OHM,10%,0.25W	01121	CB1031
R3042	307-0057-00			RES.,FXD,CMPSN:5.1 OHM,5%,0.50W	01121	EB51G5
R3043	316-0220-00			RES.,FXD,CMPSN:22 OHM,10%,0.25W	01121	CB2201
R3048	315-0823-00			RES.,FXD,CMPSN:82K OHM,5%,0.25W	01121	CB8235
R3049	316-0184-00			RES.,FXD,CMPSN:180K OHM,10%,0.25W	01121	CB1841
R3050	316-0101-00			RES.,FXD,CMPSN:100 OHM,10%,0.25W	01121	CB1011
R3052	302-0332-00			RES.,FXD,CMPSN:3.3K OHM,10%,0.50W	01121	EB3321
R3054	316-0561-00			RES.,FXD,CMPSN:560 OHM,10%,0.25W	01121	CB5611
R3056	316-0101-00			RES.,FXD,CMPSN:100 OHM,10%,0.25W	01121	CB1011
R3057	316-0270-00			RES.,FXD,CMPSN:27 OHM,10%,0.25W	01121	CB2701
R3105	315-0473-00			RES.,FXD,CMPSN:47K OHM,5%,0.25W	01121	CB4735
R3106	315-0103-00			RES.,FXD,CMPSN:10K OHM,5%,0.25W	01121	CB1035
R3108	315-0103-00			RES.,FXD,CMPSN:10K OHM,5%,0.25W	01121	CB1035
R3109	315-0223-00			RES.,FXD,CMPSN:22K OHM,5%,0.25W	01121	CB2235
R3111	315-0104-00			RES.,FXD,CMPSN:100K OHM,5%,0.25W	01121	CB1045
R3117	315-0154-00			RES.,FXD,CMPSN:150K OHM,5%,0.25W	01121	CB1545
R3119	315-0224-00			RES.,FXD,CMPSN:220K OHM,5%,0.25W	01121	CB2245
R3120	315-0123-00			RES.,FXD,CMPSN:12K OHM,5%,0.25W	01121	CB1235
R3121	315-0201-00			RES.,FXD,CMPSN:200 OHM,5%,0.25W	01121	CB2015
R3122	315-0470-00			RES.,FXD,CMPSN:47 OHM,5%,0.25W	01121	CB4705
R3127	315-0560-00			RES.,FXD,CMPSN:56 OHM,5%,0.25W	01121	CB5605
R3129	315-0331-00	B010100	B109999	RES.,FXD,CMPSN:330 OHM,5%,0.25W	01121	CB3315
R3129	315-0181-00	B110000		RES.,FXD,CMPSN:180 OHM,5%,0.25W	01121	CB1815
R3134	315-0471-00			RES.,FXD,CMPSN:470 OHM,5%,0.25W	01121	CB4715

Replaceable Electrical Parts—7704A

Ckt No.	Tektronix Part No.	Serial/Model No. Eff	Discont	Name & Description	Mfr Code	Mfr Part Number
R3135	321-0313-00			RES.,FXD,FILM:17.8K OHM,1%,0.125W	91637	MFF1816G17801F
R3136	321-0193-00			RES.,FXD,FILM:1K OHM,1%,0.125W	91637	MFF1816G10000F
R3137	321-0012-00			RES.,FXD,FILM:13 OHM,1%,0.125W	91637	MFF1816G13R00F
R3142	321-0388-00			RES.,FXD,FILM:107K OHM,1%,0.125W	91637	MFF1816G10702F
R3143	311-1239-00			RES.,VAR, NONWIR:2.5K OHM,10%,0.50W	73138	72X-76-0-252K
R3144	321-0283-00			RES.,FXD,FILM:8.66K OHM,1%,0.125W	91637	MFF1816G86600F
R3146	321-0282-00			RES.,FXD,FILM:8.45K OHM,1%,0.125W	91637	MFF1816G84500F
R3147	315-0102-00			RES.,FXD,CMPSN:1K OHM,5%,0.25W	01121	CB1025
R3150	321-0356-00			RES.,FXD,FILM:49.9K OHM,1%,0.125W	91637	MFF1816G49901F
R3152	315-0821-00			RES.,FXD,CMPSN:820 OHM,5%,0.25W	01121	CB8215
R3154	321-0286-00			RES.,FXD,FILM:9.31K OHM,1%,0.125W	91637	MFF1816G93100F
R3155	321-0339-00			RES.,FXD,FILM:33.2K OHM,1%,0.125W	91637	MFF1816G33201F
R3202	316-0471-00	B010100	B059999	RES.,FXD,CMPSN:470 OHM,10%,0.25W	01121	CB4711
R3202	315-0471-00	B060000		RES.,FXD,CMPSN:470 OHM,5%,0.25W	01121	CB4715
R3204	316-0334-00	B010100	B059999	RES.,FXD,CMPSN:330K OHM,10%,0.25W	01121	CB3341
R3204	315-0334-00	B060000		RES.,FXD,CMPSN:330K OHM,5%,0.25W	01121	CB3345
R3205	316-0221-00	B010100	B059999	RES.,FXD,CMPSN:220 OHM,10%,0.25W	01121	CB2211
R3205	315-0221-00	B060000		RES.,FXD,CMPSN:220 OHM,5%,0.25W	01121	CB2215
R3206	316-0183-00	B010100	B059999	RES.,FXD,CMPSN:18K OHM,10%,0.25W	01121	CB1831
R3206	315-0183-00	B060000		RES.,FXD,CMPSN:18K OHM,5%,0.25W	01121	CB1835
R3208	321-0924-07			RES.,FXD,FILM:40K OHM,0.1%,0.125W	91637	MFF1816C40001B
R3209	316-0274-00	B010100	B059999	RES.,FXD,CMPSN:270K OHM,10%,0.25W	01121	CB2741
R3209	315-0274-00	B060000		RES.,FXD,CMPSN:270K OHM,5%,0.25W	01121	CB2745
R3211	315-0621-00			RES.,FXD,CMPSN:620 OHM,5%,0.25W	01121	CB6215
R3212	315-0513-00			RES.,FXD,CMPSN:51K OHM,5%,0.25W	01121	CB5135
R3213	315-0272-00			RES.,FXD,CMPSN:2.7K OHM,5%,0.25W	01121	CB2725
R3214	321-0924-07			RES.,FXD,FILM:40K OHM,0.1%,0.125W	91637	MFF1816C40001B
R3216	316-0102-00	B010100	B059999	RES.,FXD,CMPSN:1K OHM,10%,0.25W	01121	CB1021
R3216	315-0102-00	B060000		RES.,FXD,CMPSN:1K OHM,5%,0.25W	01121	CB1025
R3217	315-0513-00			RES.,FXD,CMPSN:51K OHM,5%,0.25W	01121	CB5135
R3218	316-0681-00	B010100	B059999	RES.,FXD,CMPSN:680 OHM,10%,0.25W	01121	CB6811
R3218	315-0681-00	B060000		RES.,FXD,CMPSN:680 OHM,5%,0.25W	01121	CB6815
R3220	316-0331-00	B010100	B059999	RES.,FXD,CMPSN:330 OHM,10%,0.25W	01121	CB3311
R3220	315-0331-00	B060000		RES.,FXD,CMPSN:330 OHM,5%,0.25W	01121	CB3315
R3222	316-0471-00	B010100	B059999	RES.,FXD,CMPSN:470 OHM,10%,0.25W	01121	CB4711
R3222	315-0471-00	B060000		RES.,FXD,CMPSN:470 OHM,5%,0.25W	01121	CB4715
R3223	308-0703-00			RES.,FXD,WW:1.8 OHM,5%,2W	75042	BWH-1R800J
R3224	315-0753-00			RES.,FXD,CMPSN:75K OHM,5%,0.25W	01121	CB7535
R3225	315-0182-00			RES.,FXD,CMPSN:1.8K OHM,5%,0.25W	01121	CB1825
R3226	316-0334-00	B010100	B059999	RES.,FXD,CMPSN:330K OHM,10%,0.25W	01121	CB3341
R3226	315-0334-00	B060000		RES.,FXD,CMPSN:330K OHM,5%,0.25W	01121	CB3345
R3228	315-0152-00			RES.,FXD,CMPSN:1.5K OHM,5%,0.25W	01121	CB1525
R3229	316-0153-00	B010100	B059999	RES.,FXD,CMPSN:15K OHM,10%,0.25W	01121	CB1531
R3229	315-0153-00	B060000		RES.,FXD,CMPSN:15K OHM,5%,0.25W	01121	CB1535
R3230	315-0561-00			RES.,FXD,CMPSN:560 OHM,5%,0.25W	01121	CB5615
R3231	315-0182-00			RES.,FXD,CMPSN:1.8K OHM,5%,0.25W	01121	CB1825
R3232	315-0134-00			RES.,FXD,CMPSN:130K OHM,5%,0.25W	01121	CB1345
R3233	315-0512-00			RES.,FXD,CMPSN:5.1K OHM,5%,0.25W	01121	CB5125
R3234	315-0820-00			RES.,FXD,CMPSN:82 OHM,5%,0.25W	01121	CB8205
R3235	316-0184-00	B010100	B059999	RES.,FXD,CMPSN:180K OHM,10%,0.25W	01121	CB1841
R3235	315-0184-00	B060000		RES.,FXD,CMPSN:180K OHM,5%,0.25W	01121	CB1845
R3236	321-0924-07			RES.,FXD,FILM:40K OHM,0.1%,0.125W	91637	MFF1816C40001B
R3237	301-0103-00	B010100	B173849	RES.,FXD,CMPSN:10K OHM,5%,0.50W	01121	EB1035

Ckt No.	Tektronix Part No.	Serial/Model No. Eff	Dscont	Name & Description	Mfr Code	Mfr Part Number
R3237	302-0392-00	B173850		RES.,FXD,CMPSN:3.9K OHM,10%,0.50W	01121	EB3921
R3238	315-0153-00			RES.,FXD,CMPSN:15K OHM,5%,0.25W	01121	CB1535
R3239	321-1296-07			RES.,FXD,FILM:12K OHM,0.1%,0.125W	91637	MFF1816C12001B
R3240	316-0681-00	B010100	B059999	RES.,FXD,CMPSN:680 OHM,10%,0.25W	01121	CB6811
R3240	315-0681-00	B060000		RES.,FXD,CMPSN:680 OHM,5%,0.25W	01121	CB6815
R3241	308-0701-00			RES.,FXD,WW:0.12 OHM,5%,2W	75042	BWH-R1200J
R3242	316-0151-00	B010100	B059999	RES.,FXD,CMPSN:150 OHM,10%,0.25W	01121	CB1511
R3242	315-0151-00	B060000		RES.,FXD,CMPSN:150 OHM,5%,0.25W	01121	CB1515
R3245	316-0273-00	B010100	B059999	RES.,FXD,CMPSN:27K OHM,10%,0.25W	01121	CB2731
R3245	315-0273-00	B060000		RES.,FXD,CMPSN:27K OHM,5%,0.25W	01121	CB2735
R3246	316-0273-00	B010100	B059999	RES.,FXD,CMPSN:27K OHM,10%,0.25W	01121	CB2731
R3246	315-0273-00	B060000		RES.,FXD,CMPSN:27K OHM,5%,0.25W	01121	CB2735
R3248	315-0430-00			RES.,FXD,CMPSN:43 OHM,5%,0.25W	01121	CB4305
R3249	316-0562-00	B010100	B059999	RES.,FXD,CMPSN:5.6K OHM,10%,0.25W	01121	CB5621
R3249	315-0562-00	B060000		RES.,FXD,CMPSN:5.6K OHM,5%,0.25W	01121	CB5625
R3251	316-0223-00	B010100	B059999	RES.,FXD,CMPSN:22K OHM,10%,0.25W	01121	CB2231
R3251	315-0223-00	B060000		RES.,FXD,CMPSN:22K OHM,5%,0.25W	01121	CB2235
R3253	315-0152-00			RES.,FXD,CMPSN:1.5K OHM,5%,0.25W	01121	CB1525
R3254	315-0750-00			RES.,FXD,CMPSN:75 OHM,5%,0.25W	01121	CB7505
R3255	308-0701-00			RES.,FXD,WW:0.12 OHM,5%,2W	75042	BWH-R1200J
R3258	316-0103-00	B010100	B059999	RES.,FXD,CMPSN:10K OHM,10%,0.25W	01121	CB1031
R3258	315-0103-00	B060000		RES.,FXD,CMPSN:10K OHM,5%,0.25W	01121	CB1035
R3260	316-0681-00	B010100	B059999	RES.,FXD,CMPSN:680 OHM,10%,0.25W	01121	CB6811
R3260	315-0681-00	B060000		RES.,FXD,CMPSN:680 OHM,5%,0.25W	01121	CB6815
R3262	316-0470-00	B010100	B059999	RES.,FXD,CMPSN:47 OHM,10%,0.25W	01121	CB4701
R3262	315-0470-00	B060000		RES.,FXD,CMPSN:47 OHM,5%,0.25W	01121	CB4705
R3263	316-0470-00	B010100	B059999	RES.,FXD,CMPSN:47 OHM,10%,0.25W	01121	CB4701
R3263	315-0470-00	B060000		RES.,FXD,CMPSN:47 OHM,5%,0.25W	01121	CB4705
R3264	316-0274-00	B010100	B059999	RES.,FXD,CMPSN:270K OHM,10%,0.25W	01121	CB2741
R3264	315-0274-00	B060000		RES.,FXD,CMPSN:270K OHM,5%,0.25W	01121	CB2745
R3265	321-0924-07			RES.,FXD,FILM:40K OHM,0.1%,0.125W	91637	MFF1816C40001B
R3267	321-0926-07			RES.,FXD,FILM:4K OHM,0.1%,0.125W	91637	MFF1816C40000B
R3268	316-0224-00	B010100	B059999	RES.,FXD,CMPSN:220K OHM,10%,0.25W	01121	CB2241
R3268	315-0224-00	B060000		RES.,FXD,CMPSN:220K OHM,5%,0.25W	01121	CB2245
R3269	316-0103-00	B010100	B059999	RES.,FXD,CMPSN:10K OHM,10%,0.25W	01121	CB1031
R3269	315-0103-00	B060000		RES.,FXD,CMPSN:10K OHM,5%,0.25W	01121	CB1035
R3272	321-1296-07			RES.,FXD,FILM:12K OHM,0.1%,0.125W	91637	MFF1816C12001B
R3273	321-0332-07			RES.,FXD,FILM:28K OHM,0.1%,0.125W	91637	MFF1816C28001B
R3275	316-0184-00	B010100	B059999	RES.,FXD,CMPSN:180K OHM,10%,0.25W	01121	CB1841
R3275	315-0184-00	B060000		RES.,FXD,CMPSN:180K OHM,5%,0.25W	01121	CB1845
R3277	315-0124-00			RES.,FXD,CMPSN:120K OHM,5%,0.25W	01121	CB1245
R3278	316-0471-00	B010100	B059999	RES.,FXD,CMPSN:470 OHM,10%,0.25W	01121	CB4711
R3278	315-0471-00	B060000		RES.,FXD,CMPSN:470 OHM,5%,0.25W	01121	CB4715
R3280	315-0272-00			RES.,FXD,CMPSN:2.7K OHM,5%,0.25W	01121	CB2725
R3283	301-0822-00			RES.,FXD,CMPSN:8.2K OHM,5%,0.50W	01121	EB8225
R3285	316-0222-00	B010100	B059999	RES.,FXD,CMPSN:2.2K OHM,10%,0.25W	01121	CB2221
R3285	315-0222-00	B060000		RES.,FXD,CMPSN:2.2K OHM,5%,0.25W	01121	CB2225
R3287	316-0273-00	B010100	B059999	RES.,FXD,CMPSN:27K OHM,10%,0.25W	01121	CB2731
R3287	315-0273-00	B060000		RES.,FXD,CMPSN:27K OHM,5%,0.25W	01121	CB2735
R3288	316-0391-00	B010100	B059999	RES.,FXD,CMPSN:390 OHM,10%,0.25W	01121	CB3911
R3288	315-0391-00	B060000		RES.,FXD,CMPSN:390 OHM,5%,0.25W	01121	CB3915
R3289	316-0222-00	B010100	B059999	RES.,FXD,CMPSN:2.2K OHM,10%,0.25W	01121	CB2221
R3289	315-0222-00	B060000		RES.,FXD,CMPSN:2.2K OHM,5%,0.25W	01121	CB2225

Replaceable Electrical Parts—7704A

Ckt No.	Tektronix Part No.	Serial/Model No. Eff	Dscont	Name & Description	Mfr Code	Mfr Part Number
R3290	316-0681-00	B010100	B059999	RES., FXD, CMPSN:680 OHM, 1%, 0.25W	01121	CB6811
R3290	315-0681-00	B060000		RES., FXD, CMPSN:680 OHM, 5%, 0.25W	01121	CB6815
R3293	308-0701-00			RES., FXD, WW:0.12 OHM, 5%, 2W	75042	BWH-R1200J
R3294	316-0471-00	B010100	B059999	RES., FXD, CMPSN:470 OHM, 10%, 0.25W	01121	CB4711
R3294	315-0471-00	B060000		RES., FXD, CMPSN:470 OHM, 5%, 0.25W	01121	CB4715
R3301	315-0241-00			RES., FXD, CMPSN:240 OHM, 5%, 0.25W	01121	CB2415
R3302	321-0097-00	B010100	B089999	RES., FXD, FILM:100 OHM, 1%, 0.125W	91637	MFF1816G100ROF
R3302	321-0092-00	B090000		RES., FXD, FILM:88.7 OHM, 1%, 0.125W	91637	MFF1816G88R70F
R3304	321-0091-00			RES., FXD, FILM:86.6 OHM, 1%, 0.125W	91637	MFF1816G86R60F
R3306	321-0022-00			RES., FXD, FILM:16.5 OHM, 1%, 0.125W	91637	MFF1816G16R50F
R3308	321-0022-00			RES., FXD, FILM:16.5 OHM, 1%, 0.125W	91637	MFF1816G16R50F
R3310	315-0471-00			RES., FXD, CMPSN:470 OHM, 5%, 0.25W	01121	CB4715
R3312	315-0151-00			RES., FXD, CMPSN:150 OHM, 5%, 0.25W	01121	CB1515
R3313	321-0229-00			RES., FXD, FILM:2.37K OHM, 1%, 0.125W	91637	MFF1816G23700F
R3314	321-0244-00			RES., FXD, FILM:3.4K OHM, 1%, 0.125W	91637	MFF1816G34000F
R3315	315-0151-00			RES., FXD, CMPSN:150 OHM, 5%, 0.25W	01121	CB1515
R3317	321-0224-00			RES., FXD, FILM:2.1K OHM, 1%, 0.125W	91637	MFF1816G21000F
R3318	321-0208-00			RES., FXD, FILM:1.43K OHM, 1%, 0.125W	91637	MFF1816G14300F
R3319	315-0101-00			RES., FXD, CMPSN:100 OHM, 5%, 0.25W	01121	CB1015
R3320	315-0470-00			RES., FXD, CMPSN:47 OHM, 5%, 0.25W	01121	CB4705
R3321	315-0101-00			RES., FXD, CMPSN:100 OHM, 5%, 0.25W	01121	CB1015
R3323	315-0222-00			RES., FXD, CMPSN:2.2K OHM, 5%, 0.25W	01121	CB2225
R3325	315-0241-00			RES., FXD, CMPSN:240 OHM, 5%, 0.25W	01121	CB2415
R3326	315-0101-00			RES., FXD, CMPSN:100 OHM, 5%, 0.25W	01121	CB1015
R3328	321-0260-00	B010100	B010159	RES., FXD, FILM:4.99K OHM, 1%, 0.125W	91637	MFF1816G49900F
R3328	321-0262-00	B010160		RES., FXD, FILM:5.23K OHM, 1%, 0.125W	91637	MFF1816G52300F
R3330	315-0152-00			RES., FXD, CMPSN:1.5K OHM, 5%, 0.25W	01121	CB1525
R3333	315-0272-00			RES., FXD, CMPSN:2.7K OHM, 5%, 0.25W	01121	CB2725
R3334	321-0190-00			RES., FXD, FILM:931 OHM, 1%, 0.125W	91637	MFF1816G931ROF
R3340	315-0181-00			RES., FXD, CMPSN:180 OHM, 5%, 0.25W	01121	CB1815
R3341	315-0123-00			RES., FXD, CMPSN:12K OHM, 5%, 0.25W	01121	CB1235
R3343	315-0181-00			RES., FXD, CMPSN:180 OHM, 5%, 0.25W	01121	CB1815
R3344	315-0123-00			RES., FXD, CMPSN:12K OHM, 5%, 0.25W	01121	CB1235
R3346	315-0201-00			RES., FXD, CMPSN:200 OHM, 5%, 0.25W	01121	CB2015
R3347	315-0752-00			RES., FXD, CMPSN:7.5K OHM, 5%, 0.25W	01121	CB7525
R3348	315-0101-00			RES., FXD, CMPSN:100 OHM, 5%, 0.25W	01121	CB1015
R3349	315-0101-00			RES., FXD, CMPSN:100 OHM, 5%, 0.25W	01121	CB1015
R3352	315-0102-00			RES., FXD, CMPSN:1K OHM, 5%, 0.25W	01121	CB1025
R3354	315-0821-00			RES., FXD, CMPSN:820 OHM, 5%, 0.25W	01121	CB8215
R3356	315-0561-00			RES., FXD, CMPSN:560 OHM, 5%, 0.25W	01121	CB5615
R3358	321-0143-00			RES., FXD, FILM:301 OHM, 1%, 0.125W	91637	MFF1816G301ROF
R3360	321-0226-00			RES., FXD, FILM:2.21K OHM, 1%, 0.125W	91637	MFF1816G22100F
R3361	321-0180-00			RES., FXD, FILM:732 OHM, 1%, 0.125W	91637	MFF1816G732ROF
R3363	321-0189-00			RES., FXD, FILM:909 OHM, 1%, 0.125W	91637	MFF1816G909ROF
R3364	315-0390-00			RES., FXD, CMPSN:39 OHM, 5%, 0.25W	01121	CB3905
R3367	315-0102-00			RES., FXD, CMPSN:1K OHM, 5%, 0.25W	01121	CB1025
R3368	315-0102-00			RES., FXD, CMPSN:1K OHM, 5%, 0.25W	01121	CB1025
R3371	315-0510-00			RES., FXD, CMPSN:51 OHM, 5%, 0.25W	01121	CB5105
R3372	315-0473-00			RES., FXD, CMPSN:47K OHM, 5%, 0.25W	01121	CB4735
R3373	315-0221-00			RES., FXD, CMPSN:220 OHM, 5%, 0.25W	01121	CB2215
R3391	315-0104-00			RES., FXD, CMPSN:100K OHM, 5%, 0.25W	01121	CB1045
R3393	315-0152-00			RES., FXD, CMPSN:1.5K OHM, 5%, 0.25W	01121	CB1525
R3401	315-0303-00			RES., FXD, CMPSN:30K OHM, 5%, 0.25W	01121	CB3035

Ckt No.	Tektronix Part No.	Serial/Model No. Eff	Dscont	Name & Description	Mfr Code	Mfr Part Number
R3402	315-0203-00			RES.,FXD,CMPSN:20K OHM,5%,0.25W	01121	CB2035
R3403	315-0203-00			RES.,FXD,CMPSN:20K OHM,5%,0.25W	01121	CB2035
R3404	315-0203-00			RES.,FXD,CMPSN:20K OHM,5%,0.25W	01121	CB2035
R3405	315-0203-00			RES.,FXD,CMPSN:20K OHM,5%,0.25W	01121	CB2035
R3406	315-0134-00			RES.,FXD,CMPSN:130K OHM,5%,0.25W	01121	CB1345
R3407	311-1224-00			RES.,VAR,NONWIR:500 OHM,20%,0.50W	32997	3386F-T04-501
R3408	321-0300-00			RES.,FXD,FILM:13K OHM,1%,0.125W	91637	MFF1816G13001F
R3409	321-0259-00			RES.,FXD,FILM:4.87K OHM,1%,0.125W	91637	MFF1816G48700F
R3410	321-0181-00			RES.,FXD,FILM:750 OHM,1%,0.125W	91637	MFF1816G750R0F
R3411	321-0297-00			RES.,FXD,FILM:12.1K OHM,1%,0.125W	91637	MFF1816G12101F
R3412	321-0212-00			RES.,FXD,FILM:1.58K OHM,1%,0.125W	91637	MFF1816G15800F
R3414	315-0152-00			RES.,FXD,CMPSN:1.5K OHM,5%,0.25W	01121	CB1525
R3416	315-0222-00			RES.,FXD,CMPSN:2.2K OHM,5%,0.25W	01121	CB2225
R3418	321-0268-00			RES.,FXD,FILM:6.04K OHM,1%,0.125W	91637	MFF1816G60400F
R3419	321-0322-00			RES.,FXD,FILM:22.1K OHM,1%,0.125W	91637	MFF1816G22101F
R3420	321-0262-00			RES.,FXD,FILM:5.23K OHM,1%,0.125W	91637	MFF1816G52300F
R3422	311-1224-00			RES.,VAR,NONWIR:500 OHM,20%,0.50W	32997	3386F-T04-501
R3423	321-0372-00			RES.,FXD,FILM:73.2K OHM,1%,0.125W	91637	MFF1816G73201F
R3425	321-0403-00			RES.,FXD,FILM:154K OHM,1%,0.125W	91637	MFF1816G15402F
R3427	315-0472-00			RES.,FXD,CMPSN:4.7K OHM,5%,0.25W	01121	CB4725
R3430	315-0432-00			RES.,FXD,CMPSN:4.3K OHM,5%,0.25W	01121	CB4325
R3431	315-0683-00			RES.,FXD,CMPSN:68K OHM,5%,0.25W	01121	CB6835
R3432	315-0153-00			RES.,FXD,CMPSN:15K OHM,5%,0.25W	01121	CB1535
R3433	315-0302-00			RES.,FXD,CMPSN:3K OHM,5%,0.25W	01121	CB3025
R3434	315-0393-00			RES.,FXD,CMPSN:39K OHM,5%,0.25W	01121	CB3935
R3435	315-0103-00			RES.,FXD,CMPSN:10K OHM,5%,0.25W	01121	CB1035
R3436	315-0183-00			RES.,FXD,CMPSN:18K OHM,5%,0.25W	01121	CB1835
R3437	311-1225-00			RES.,VAR,NONWIR:1K OHM,20%,0.50W	32997	3386F-T04-102
R3438	315-0104-00			RES.,FXD,CMPSN:100K OHM,5%,0.25W	01121	CB1045
R3439	315-0152-00			RES.,FXD,CMPSN:1.5K OHM,5%,0.25W	01121	CB1525
R3440	315-0510-00			RES.,FXD,CMPSN:51 OHM,5%,0.25W	01121	CB5105
R3441	315-0752-00			RES.,FXD,CMPSN:7.5K OHM,5%,0.25W	01121	CB7525
R3442	315-0242-00			RES.,FXD,CMPSN:2.4K OHM,5%,0.25W	01121	CB2425
R3445	315-0152-00			RES.,FXD,CMPSN:1.5K OHM,5%,0.25W	01121	CB1525
R3447	315-0512-00			RES.,FXD,CMPSN:5.1K OHM,5%,0.25W	01121	CB5125
R3449	315-0512-00			RES.,FXD,CMPSN:5.1K OHM,5%,0.25W	01121	CB5125
R3450	315-0102-00			RES.,FXD,CMPSN:1K OHM,5%,0.25W	01121	CB1025
R3451	315-0102-00			RES.,FXD,CMPSN:1K OHM,5%,0.25W	01121	CB1025
R3452	315-0102-00			RES.,FXD,CMPSN:1K OHM,5%,0.25W	01121	CB1025
R3466	321-0153-00			RES.,FXD,FILM:383 OHM,1%,0.125W	91637	MFF1816G383R0F
R3468	321-0191-00	B010100	B179999	RES.,FXD,FILM:953 OHM,1%,0.125W	91637	MFF1816G953R0F
R3468	321-0641-00	B180000		RES.,FXD,FILM:1.8K OHM,1%,0.125W	91637	MFF1816G18000F
R3470	315-0102-00			RES.,FXD,CMPSN:1K OHM,5%,0.25W	01121	CB1025
R3472	315-0272-00			RES.,FXD,CMPSN:2.7K OHM,5%,0.25W	01121	CB2725
R3473	315-0512-00			RES.,FXD,CMPSN:5.1K OHM,5%,0.25W	01121	CB5125
R3474	315-0303-00	XB050000		RES.,FXD,CMPSN:30K OHM,5%,0.25W	01121	CB3035
R3475	315-0912-00			RES.,FXD,CMPSN:9.1K OHM,5%,0.25W	01121	CB9125
R3476	321-0296-00			RES.,FXD,FILM:11.8K OHM,1%,0.125W	91637	MFF1816G11801F
R3477	315-0823-00			RES.,FXD,CMPSN:82K OHM,5%,0.25W	01121	CB8235
R3478	315-0753-00	XB050000		RES.,FXD,CMPSN:75K OHM,5%,0.25W	01121	CB7535
R3479	315-0823-00	XB050000		RES.,FXD,CMPSN:82K OHM,5%,0.25W	01121	CB8235
R3480	321-0222-00			RES.,FXD,FILM:2K OHM,1%,0.125W	91637	MFF1816G20000F
R3481	315-0223-00			RES.,FXD,CMPSN:22K OHM,5%,0.25W	01121	CB2235

Replaceable Electrical Parts—7704A

Ckt No.	Tektronix Part No.	Serial/Model No. Eff	Dscont	Name & Description	Mfr Code	Mfr Part Number
R3482	321-0250-00			RES., FXD, FILM:3.92K OHM, 1%, 0.125W	91637	MFF1816G39200F
R3483	315-0332-00			RES., FXD, CMPSN:3.3K OHM, 5%, 0.25W	01121	CB3325
R3484	321-0216-00			RES., FXD, FILM:1.74K OHM, 1%, 0.125W	91637	MFF1816G17400F
R3485	321-0245-00			RES., FXD, FILM:3.48K OHM, 1%, 0.125W	91637	MFF1816G34800F
R3486	321-0199-00			RES., FXD, FILM:1.15K OHM, 1%, 0.125W	91637	MFF1816G11500F
R3487	321-0273-00			RES., FXD, FILM:6.81K OHM, 1%, 0.125W	91637	MFF1816G68100F
R3488	321-0193-00			RES., FXD, FILM:1K OHM, 1%, 0.125W	91637	MFF1816G10000F
R3489	321-0209-00			RES., FXD, FILM:1.47K OHM, 1%, 0.125W	91637	MFF1816G14700F
R3490	311-1225-00			RES., VAR, NONWIR:1K OHM, 20%, 0.50W	32997	3386F-T04-102
R3491	321-0204-00			RES., FXD, FILM:1.3K OHM, 1%, 0.125W	91637	MFF1816G13000F
R3492	321-0245-00			RES., FXD, FILM:3.48K OHM, 1%, 0.125W	91637	MFF1816G34800F
R3493	315-0152-00			RES., FXD, CMPSN:1.5K OHM, 5%, 0.25W	01121	CB1525
R3494	315-0511-00			RES., FXD, CMPSN:510 OHM, 5%, 0.25W	01121	CB5115
R3495	315-0101-00	XB205301		RES., FXD, CMPSN:100 OHM, 5%, 0.25W	01121	CB1015
R3497	321-0241-00			RES., FXD, FILM:3.16K OHM, 1%, 0.125W	91637	MFF1816G31600F
R3498	321-0255-00			RES., FXD, FILM:4.42K OHM, 1%, 0.125W	91637	MFF1816G44200F
R3499	315-0152-00			RES., FXD, CMPSN:1.5K OHM, 5%, 0.25W	01121	CB1525
R4101	315-0124-00			RES., FXD, CMPSN:120K OHM, 5%, 0.25W	01121	CB1245
R4104	315-0332-00			RES., FXD, CMPSN:3.3K OHM, 5%, 0.25W	01121	CB3325
R4105	315-0821-00			RES., FXD, CMPSN:820 OHM, 5%, 0.25W	01121	CB8215
R4106	315-0392-00			RES., FXD, CMPSN:3.9K OHM, 5%, 0.25W	01121	CB3925
R4108	315-0244-00			RES., FXD, CMPSN:240K OHM, 5%, 0.25W	01121	CB2445
R4112	315-0331-00			RES., FXD, CMPSN:330 OHM, 5%, 0.25W	01121	CB3315
R4114	315-0681-00			RES., FXD, CMPSN:680 OHM, 5%, 0.25W	01121	CB6815
R4115	315-0150-00			RES., FXD, CMPSN:15 OHM, 5%, 0.25W	01121	CB1505
R4120	315-0474-00			RES., FXD, CMPSN:470K OHM, 5%, 0.25W	01121	CB4745
R4123	311-1235-00			RES., VAR, NONWIR:100K OHM, 20%, 0.50W	32997	3386F-T04-104
R4131	315-0471-00			RES., FXD, CMPSN:470 OHM, 5%, 0.25W	01121	CB4715
R4133	321-0258-00			RES., FXD, FILM:4.75K OHM, 1%, 0.125W	91637	MFF1816G47500F
R4135	311-1232-00			RES., VAR, NONWIR:50K OHM, 20%, 0.50W	32997	3386F-T04-503
R4136	315-0273-00			RES., FXD, CMPSN:27K OHM, 5%, 0.25W	01121	CB2735
R4137	321-0168-00			RES., FXD, FILM:549 OHM, 1%, 0.125W	91637	MFF1816G54900F
R4142	315-0304-00			RES., FXD, CMPSN:300K OHM, 5%, 0.25W	01121	CB3045
R4145	315-0473-00			RES., FXD, CMPSN:47K OHM, 5%, 0.25W	01121	CB4735
R4151	315-0123-00			RES., FXD, CMPSN:12K OHM, 5%, 0.25W	01121	CB1235
R4153	315-0102-00			RES., FXD, CMPSN:1K OHM, 5%, 0.25W	01121	CB1025
R4157	315-0104-00			RES., FXD, CMPSN:100K OHM, 5%, 0.25W	01121	CB1045
R4159	315-0513-00			RES., FXD, CMPSN:51K OHM, 5%, 0.25W	01121	CB5135
R4161	315-0470-00			RES., FXD, CMPSN:47 OHM, 5%, 0.25W	01121	CB4705
R4163	315-0152-00	XB170000		RES., FXD, CMPSN:1.5K OHM, 5%, 0.25W	01121	CB1525
R4167	315-0511-00			RES., FXD, CMPSN:510 OHM, 5%, 0.25W	01121	CB5115
R4171	315-0222-00			RES., FXD, CMPSN:2.2K OHM, 5%, 0.25W	01121	CB2225
R4173	315-0102-00			RES., FXD, CMPSN:1K OHM, 5%, 0.25W	01121	CB1025
R4175	315-0222-00			RES., FXD, CMPSN:2.2K OHM, 5%, 0.25W	01121	CB2225
R4177	315-0153-00			RES., FXD, CMPSN:15K OHM, 5%, 0.25W	01121	CB1535
R4183	321-0172-00			RES., FXD, FILM:604 OHM, 1%, 0.125W	91637	MFF1816G60400F
R4185	321-0138-00			RES., FXD, FILM:267 OHM, 1%, 0.125W	91637	MFF1816G26700F
R4187	321-0289-00			RES., FXD, FILM:10K OHM, 1%, 0.125W	91637	MFF1816G10001F
R4191	321-0126-00			RES., FXD, FILM:200 OHM, 1%, 0.125W	91637	MFF1816G20000F
R4193	321-0181-00			RES., FXD, FILM:750 OHM, 1%, 0.125W	91637	MFF1816G75000F
R4195	303-0121-00			RES., FXD, CMPSN:120 OHM, 5%, 1W	01121	GB1215
R4197	311-1223-00			RES., VAR, NONWIR:250 OHM, 10%, 0.50W	32997	3386F-T04-251
R4201	316-0101-00			RES., FXD, CMPSN:100 OHM, 10%, 0.25W	01121	CB1011

Ckt No.	Tektronix Part No.	Serial/Model No. Eff	Dscont	Name & Description	Mfr Code	Mfr Part Number
R4205	302-0152-00	B010100	B039999	RES.,FXD,CMPSN:1.5K OHM,10%,0.50W	01121	EB1521
R4205	301-0272-00	B040000		RES.,FXD,CMPSN:2.7K OHM,5%,0.50W	01121	EB2725
R4207	316-0472-00			RES.,FXD,CMPSN:4.7K OHM,10%,0.25W	01121	CB4721
R4208	316-0472-00			RES.,FXD,CMPSN:4.7K OHM,10%,0.25W	01121	CB4721
R4209	316-0472-00			RES.,FXD,CMPSN:4.7K OHM,10%,0.25W	01121	CB4721
R4211	302-0331-00			RES.,FXD,CMPSN:330 OHM,10%,0.50W	01121	EB3311
R4213	316-0124-00			RES.,FXD,CMPSN:120K OHM,10%,0.25W	01121	CB1241
R4214	302-0335-00			RES.,FXD,CMPSN:3.3M OHM,10%,0.50W	01121	EB3351
R4215	302-0183-00			RES.,FXD,CMPSN:18K OHM,10%,0.50W	01121	EB1831
R4216	302-0226-00			RES.,FXD,CMPSN:22M OHM,10%,0.50W	01121	EB2261
R4217	302-0335-00			RES.,FXD,CMPSN:3.3M OHM,10%,0.50W	01121	EB3351
R4218	302-0104-00			RES.,FXD,CMPSN:100K OHM,10%,0.50W	01121	EB1041
R4219	307-0113-00			RES.,FXD,CMPSN:5.1 OHM,5%,0.25W	01121	CB51G5
R4220	301-0103-00			RES.,FXD,CMPSN:10K OHM,5%,0.50W	01121	EB1035
R4221	316-0101-00			RES.,FXD,CMPSN:100 OHM,10%,0.25W	01121	CB1011
R4222	316-0104-00			RES.,FXD,CMPSN:100K OHM,10%,0.25W	01121	CB1041
R4235	302-0183-00			RES.,FXD,CMPSN:18K OHM,10%,0.50W	01121	EB1831
R4237	302-0104-00			RES.,FXD,CMPSN:100K OHM,10%,0.50W	01121	EB1041
R4239	302-0226-00			RES.,FXD,CMPSN:22M OHM,10%,0.50W	01121	EB2261
R4240	307-0290-02	B010100	B039999	RES.,FXD,FILM:400.76K OHM,	80009	307-0290-02
R4241				RES.,FXD,FILM:24.5M OHM,		
R4242				RES.,FXD,FILM:23.4M OHM		
R4243				RES.,FXD,FILM:7.4M OHM,		
R4240	307-0386-02	B040000		RES.,FXD,FILM:400.76K OHM,	80009	307-0386-02
R4241				RES.,FXD,FILM:24.5M OHM,		
R4242				RES.,FXD,FILM:20.4M OHM,		
R4243				RES.,FXD,FILM:7.37M OHM,		
R4244	302-0102-00			RES.,FXD,CMPSN:1K OHM,10%,0.50W	01121	EB1021
R4251	316-0103-00			RES.,FXD,CMPSN:10K OHM,10%,0.25W	01121	CB1031
R4254	315-0243-00			RES.,FXD,CMPSN:24K OHM,5%,0.25W	01121	CB2435
R4255	316-0103-00			RES.,FXD,CMPSN:10K OHM,10%,0.25W	01121	CB1031
R4256	316-0562-00			RES.,FXD,CMPSN:5.6K OHM,10%,0.25W	01121	CB5621
R4257	316-0221-00			RES.,FXD,CMPSN:220 OHM,10%,0.25W	01121	CB2211
R4258	308-0702-00			RES.,FXD,WW:0.33 OHM,5%,2W	75042	BWH-R3300J
R4261	301-0304-00			RES.,FXD,CMPSN:300K OHM,5%,0.50W	01121	EB3045
R4263	301-0304-00			RES.,FXD,CMPSN:300K OHM,5%,0.50W	01121	EB3045
R4265	301-0304-00			RES.,FXD,CMPSN:300K OHM,5%,0.50W	01121	EB3045
R4267	301-0304-00			RES.,FXD,CMPSN:300K OHM,5%,0.50W	01121	EB3045
R4269	301-0304-00			RES.,FXD,CMPSN:300K OHM,5%,0.50W	01121	EB3045
R4271	301-0304-00			RES.,FXD,CMPSN:300K OHM,5%,0.50W	01121	EB3045
R4273	301-0304-00			RES.,FXD,CMPSN:300K OHM,5%,0.50W	01121	EB3045
R4275	301-0304-00			RES.,FXD,CMPSN:300K OHM,5%,0.50W	01121	EB3045
R4277	301-0304-00			RES.,FXD,CMPSN:300K OHM,5%,0.50W	01121	EB3045
R4279	301-0304-00	B010100	B109999X	RES.,FXD,CMPSN:300K OHM,5%,0.50W	01121	EB3045
R4300	321-0186-00			RES.,FXD,FILM:845 OHM,1%,0.125W	91637	MF1816G845ROF
R4301	315-0302-00			RES.,FXD,CMPSN:3K OHM,5%,0.25W	01121	CB3025
R4302	321-0073-00			RES.,FXD,FILM:56.2 OHM,1%,0.125W	91637	MF1816G56R20F
R4303	315-0102-00			RES.,FXD,CMPSN:1K OHM,5%,0.25W	01121	CB1025
R4304	315-0221-00	B010100	B079999	RES.,FXD,CMPSN:220 OHM,5%,0.25W	01121	CB2215
R4304	315-0101-00	B080000		RES.,FXD,CMPSN:100 OHM,5%,0.25W	01121	CB1015
R4305	321-0070-00			RES.,FXD,FILM:52.3 OHM,1%,0.125W	91637	MF1816G52R30F
R4307	323-0168-00			RES.,FXD,FILM:549 OHM,1%,0.50W	75042	CECT0-5490F
R4309	323-0168-00			RES.,FXD,FILM:549 OHM,1%,0.50W	75042	CECT0-5490F

Replaceable Electrical Parts—7704A

Ckt No.	Tektronix Part No.	Serial/Model No. Eff	Dscont	Name & Description	Mfr Code	Mfr Part Number
R4310	311-1222-00			RES.,VAR, NONWIR:100 OHM,20%,0.50W	32997	3386F-T04-101
R4311	321-0098-00	B010100	B029999	RES.,FXD,FILM:102 OHM,1%,0.125W	91637	MFF1816G102ROF
R4311	321-0093-00	B030000	B079999	RES.,FXD,FILM:90.9 OHM,1%,0.125W	91637	MFF1816G90R90F
R4311	321-0089-00	B080000		RES.,FXD,FILM:82.5 OHM,1%,0.125W	91637	MFF1816G82R50F
R4312	315-0202-00	B010100	B099999	RES.,FXD,CMPSN:2K OHM,5%,0.25W	01121	CB2025
R4312	315-0152-00	B100000	B109999	RES.,FXD,CMPSN:1.5K OHM,5%,0.25W	01121	CB1525
R4312	315-0112-00	B110000		RES.,FXD,CMPSN:1.1K OHM,5%,0.25W	01121	CB1125
R4313	315-0511-00	B010100	B079999	RES.,FXD,CMPSN:510 OHM,5%,0.25W	01121	CB5115
R4313	315-0102-00	B080000		RES.,FXD,CMPSN:1K OHM,5%,0.25W	01121	CB1025
R4315	321-0097-00			RES.,FXD,FILM:100 OHM,1%,0.125W	91637	MFF1816G100ROF
R4321	321-0096-00			RES.,FXD,FILM:97.6 OHM,1%,0.125W	91637	MFF1816G97R60F
R4322	317-0510-00	XB050000		RES.,FXD,CMPSN:51 OHM,5%,0.125W	01121	BB5105
R4323	321-0178-00	B010100	B079999	RES.,FXD,FILM:698 OHM,1%,0.125W	91637	MFF1816G698ROF
R4323	321-0168-00	B080000		RES.,FXD,FILM:549 OHM,1%,0.125W	91637	MFF1816G549ROF
R4324	321-0108-00			RES.,FXD,FILM:130 OHM,1%,0.125W	91637	MFF1816G130ROF
R4325	311-1224-00	B010100	B079999	RES.,VAR, NONWIR:500 OHM,20%,0.50W	32997	3386F-T04-501
R4325	311-1222-00	B080000		RES.,VAR, NONWIR:100 OHM,20%,0.50W	32997	3386F-T04-101
R4327	323-0086-00			RES.,FXD,FILM:76.8 OHM,1%,0.50W	75042	CECTO-76R80F
R4328	308-0292-00			RES.,FXD,WW:2.2K OHM,5%,3W	63743	34824
R4329	323-0126-00			RES.,FXD,FILM:200 OHM,1%,0.50W	75042	CECTO-2000F
R4331	321-0096-00			RES.,FXD,FILM:97.6 OHM,1%,0.125W	91637	MFF1816G97R60F
R4332	317-0510-00	XB050000		RES.,FXD,CMPSN:51 OHM,5%,0.125W	01121	BB5105
R4333	321-0178-00	B010100	B079999	RES.,FXD,FILM:698 OHM,1%,0.125W	91637	MFF1816G698ROF
R4333	321-0168-00	B080000		RES.,FXD,FILM:549 OHM,1%,0.125W	91637	MFF1816G549ROF
R4335	321-0120-00			RES.,FXD,FILM:174 OHM,1%,0.125W	91637	MFF1816G174ROF
R4339	323-0126-00			RES.,FXD,FILM:200 OHM,1%,0.50W	75042	CECTO-2000F
R4340	323-0101-00			RES.,FXD,FILM:110 OHM,1%,0.50W	75042	CECTO-1100F
R4342	323-0133-00			RES.,FXD,FILM:237 OHM,1%,0.50W	75042	CECTO-2370F
R4344	321-0190-00	B010100	B079999	RES.,FXD,FILM:931 OHM,1%,0.125W	91637	MFF1816G931ROF
R4344	321-0185-00	B080000		RES.,FXD,FILM:825 OHM,1%,0.125W	91637	MFF1816G825ROF
R4346	311-1222-00			RES.,VAR, NONWIR:100 OHM,20%,0.50W	32997	3386F-T04-101
R4348	321-0177-00			RES.,FXD,FILM:681 OHM,1%,0.125W	91637	MFF1816G681ROF
R4351	321-0186-00			RES.,FXD,FILM:845 OHM,1%,0.125W	91637	MFF1816G845ROF
R4352	321-0244-00			RES.,FXD,FILM:3.4K OHM,1%,0.125W	91637	MFF1816G34000F
R4354	315-0152-00	B010100	B109999	RES.,FXD,CMPSN:1.5K OHM,5%,0.25W	01121	CB1525
R4354	315-0222-00	B110000		RES.,FXD,CMPSN:2.2K OHM,5%,0.25W	01121	CB2225
R4356	315-0820-00			RES.,FXD,CMPSN:82 OHM,5%,0.25W	01121	CB8205
R4358	303-0202-00			RES.,FXD,CMPSN:2K OHM,5%,1W	01121	GB2025
R4360	323-0178-00			RES.,FXD,FILM:698 OHM,1%,0.50W	75042	CECTO-6980F
R4361	321-0193-00			RES.,FXD,FILM:1K OHM,1%,0.125W	91637	MFF1816G10000F
R4363	321-0251-00			RES.,FXD,FILM:4.02K OHM,1%,0.125W	91637	MFF1816G40200F
R4364	315-0681-00	B010100	B109999	RES.,FXD,CMPSN:680 OHM,5%,0.25W	01121	CB6815
R4364	315-0102-00	B110000		RES.,FXD,CMPSN:1K OHM,5%,0.25W	01121	CB1025
R4366	315-0820-00			RES.,FXD,CMPSN:82 OHM,5%,0.25W	01121	CB8205
R4368	303-0202-00			RES.,FXD,CMPSN:2K OHM,5%,1W	01121	GB2025
R4370	301-0273-00	B010100	B109999	RES.,FXD,CMPSN:27K OHM,5%,0.50W	01121	EB2735
R4370	303-0153-00	B110000		RES.,FXD,CMPSN:15K OHM,5%,1W	01121	GB1535
R4371	323-0233-00			RES.,FXD,FILM:2.61K OHM,1%,0.50W	75042	CECTO-2611F
R4373	315-0470-00			RES.,FXD,CMPSN:47 OHM,5%,0.25W	01121	CB4705
R4374	323-0316-00			RES.,FXD,FILM:19.1K OHM,1%,0.50W	75042	CECTO-1912F
R4375	315-0220-00			RES.,FXD,CMPSN:22 OHM,5%,0.25W	01121	CB2205
R4377	321-0282-00			RES.,FXD,FILM:8.45K OHM,1%,0.125W	91637	MFF1816G84500F
R4379	323-0335-00			RES.,FXD,FILM:30.1K OHM,1%,0.50W	75042	CECTO-3012F

Ckt No.	Tektronix Part No.	Serial/Model No. Eff	Dscont	Name & Description	Mfr Code	Mfr Part Number
R4380	315-0220-00			RES., FXD, CMPSN:22 OHM, 5%, 0.25W	01121	CB2205
R4381	315-0332-00			RES., FXD, CMPSN:3.3K OHM, 5%, 0.25W	01121	CB3325
R4382	321-0224-00	B010100	B079999	RES., FXD, FILM:2.1K OHM, 1%, 0.125W	91637	MFF1816G21000F
R4382	321-0226-00	B080000		RES., FXD, FILM:2.21K OHM, 1%, 0.125W	91637	MFF1816G22100F
R4384	321-0230-00	B010100	B079999	RES., FXD, FILM:2.43K OHM, 1%, 0.125W	91637	MFF1816G24300F
R4384	321-0228-00	B080000		RES., FXD, FILM:2.32K OHM, 1%, 0.125W	91637	MFF1816G23200F
R4385	311-0633-00			RES., VAR, NONWIR:5K OHM, 10%, 0.50W	73138	82-30-0
R4387	321-0224-00	B010100	B079999	RES., FXD, FILM:2.1K OHM, 1%, 0.125W	91637	MFF1816G21000F
R4387	321-0226-00	B080000		RES., FXD, FILM:2.21K OHM, 1%, 0.125W	91637	MFF1816G22100F
R4389	321-0230-00	B010100	B079999	RES., FXD, FILM:2.43K OHM, 1%, 0.125W	91637	MFF1816G24300F
R4389	321-0228-00	B080000		RES., FXD, FILM:2.32K OHM, 1%, 0.125W	91637	MFF1816G23200F
R4390	315-0332-00			RES., FXD, CMPSN:3.3K OHM, 5%, 0.25W	01121	CB3325
R4391	323-0316-00			RES., FXD, FILM:19.1K OHM, 1%, 0.50W	75042	CECT0-1912F
R4393	315-0220-00			RES., FXD, CMPSN:22 OHM, 5%, 0.25W	01121	CB2205
R4394	315-0470-00			RES., FXD, CMPSN:47 OHM, 5%, 0.25W	01121	CB4705
R4395	323-0233-00			RES., FXD, FILM:2.61K OHM, 1%, 0.50W	75042	CECT0-2611F
R4396	301-0273-00	B010100	B109999	RES., FXD, CMPSN:27K OHM, 5%, 0.50W	01121	EB2735
R4396	303-0153-00	B110000		RES., FXD, CMPSN:15K OHM, 5%, 1W	01121	GB1535
R4397	315-0201-00			RES., FXD, CMPSN:200 OHM, 5%, 0.25W	01121	CB2015
R4401	321-0158-00			RES., FXD, FILM:432 OHM, 1%, 0.125W	91637	MFF1816G432ROF
R4403	321-0158-00			RES., FXD, FILM:432 OHM, 1%, 0.125W	91637	MFF1816G432ROF
R4404	311-0978-00			RES., VAR, NONWIR:250 OHM, 10%, 0.50W	80740	62-67-3
R4405	321-0040-00			RES., FXD, FILM:25.5 OHM, 1%, 0.125W	91637	MFF1816G25R50F
R4406	311-0605-00			RES., VAR, NONWIR:200 OHM, 10%, 0.50W	80740	62-54-3
R4407	321-0040-00			RES., FXD, FILM:25.5 OHM, 1%, 0.125W	91637	MFF1816G25R50F
R4410	321-0076-00			RES., FXD, FILM:60.4 OHM, 1%, 0.125W	91637	MFF1816G60R40F
R4411	321-0076-00			RES., FXD, FILM:60.4 OHM, 1%, 0.125W	91637	MFF1816G60R40F
R4413	321-0184-00			RES., FXD, FILM:806 OHM, 1%, 0.125W	91637	MFF1816G806ROF
R4415	311-0634-00			RES., VAR, NONWIR:500 OHM, 10%, 0.50W	73138	82-31-0
R4416	315-0222-00			RES., FXD, CMPSN:2.2K OHM, 5%, 0.25W	01121	CB2225
R4417	315-0151-00			RES., FXD, CMPSN:150 OHM, 5%, 0.25W	01121	CB1515
R4418	301-0330-00			RES., FXD, CMPSN:33 OHM, 5%, 0.50W	01121	EB3305
R4419	315-0330-00			RES., FXD, CMPSN:33 OHM, 5%, 0.25W	01121	CB3305
R4420	301-0562-00	XB120000		RES., FXD, CMPSN:5.6K OHM, 5%, 0.50W	01121	EB5625
R4421	321-0771-03			RES., FXD, FILM:50 OHM, 0.25%, 0.125W	91637	MFF1816D50R00C
R4422	321-0260-00	XB120000		RES., FXD, FILM:4.99K OHM, 1%, 0.125W	91637	MFF1816G49900F
R4423	311-0633-00			RES., VAR, NONWIR:5K OHM, 10%, 0.50W	73138	82-30-0
R4424	315-0182-00			RES., FXD, CMPSN:1.8K OHM, 5%, 0.25W	01121	CB1825
R4425	321-0296-00	XB120000		RES., FXD, FILM:11.8K OHM, 1%, 0.125W	91637	MFF1816G11801F
R4427	311-0635-00			RES., VAR, NONWIR:1K OHM, 10%, 0.50W	73138	82-32-0
R4431	321-0076-00			RES., FXD, FILM:60.4 OHM, 1%, 0.125W	91637	MFF1816G60R40F
R4432	321-0076-00			RES., FXD, FILM:60.4 OHM, 1%, 0.125W	91637	MFF1816G60R40F
R4434	321-0228-00			RES., FXD, FILM:2.32K OHM, 1%, 0.125W	91637	MFF1816G23200F
R4436	321-0228-00			RES., FXD, FILM:2.32K OHM, 1%, 0.125W	91637	MFF1816G23200F
R4438	317-0511-00			RES., FXD, CMPSN:510 OHM, 5%, 0.125W	01121	BB5115
R4439	321-0095-00			RES., FXD, FILM:95.3 OHM, 1%, 0.125W	91637	MFF1816G95R30F
R4441	321-0771-03			RES., FXD, FILM:50 OHM, 0.25%, 0.125W	91637	MFF1816D50R00C
R4450	317-0221-00	XB010130		RES., FXD, CMPSN:220 OHM, 5%, 0.125W	01121	BB2215
R4451	321-0147-00			RES., FXD, FILM:332 OHM, 1%, 0.125W	91637	MFF1816G332ROF
R4452	317-0180-00			RES., FXD, CMPSN:18 OHM, 5%, 0.125W	01121	BB1805
R4453	321-0158-00	B010100	B010129	RES., FXD, FILM:432 OHM, 1%, 0.125W	91637	MFF1816G432ROF
R4453	311-0634-00	B010130	B029999	RES., VAR, NONWIR:500 OHM, 10%, 0.50W	73138	82-31-0
R4453	311-0635-00	B030000		RES., VAR, NONWIR:1K OHM, 10%, 0.50W	73138	82-32-0

Replaceable Electrical Parts—7704A

Ckt No.	Tektronix Part No.	Serial/Model No. Eff	Dscont	Name & Description	Mfr Code	Mfr Part Number
R4454	317-0180-00			RES.,FXD,CMPSN:18 OHM,5%,0.125W	01121	BB1805
R4455	321-0169-00			RES.,FXD,FILM:562 OHM,1%,0.125W	91637	MFF1816G562ROF
R4456	323-0126-00			RES.,FXD,FILM:200 OHM,1%,0.50W	75042	CECT0-2000F
R4457	323-0126-00			RES.,FXD,FILM:200 OHM,1%,0.50W	75042	CECT0-2000F
R4458	323-0107-00			RES.,FXD,FILM:127 OHM,1%,0.50W	75042	CECT0-1270F
R4459	323-0012-00			RES.,FXD,FILM:13 OHM,1%,0.50W	91637	MFF1226G13R00F
R4460	317-0221-00	XB010130		RES.,FXD,CMPSN:220 OHM,5%,0.125W	01121	BB2215
R4461	321-0145-00	B010100	B010129	RES.,FXD,FILM:316 OHM,1%,0.125W	91637	MFF1816G316ROF
R4461	311-0635-00	B010130		RES.,VAR,NONWIR:1K OHM,10%,0.50W	73138	82-32-0
R4462	317-0180-00			RES.,FXD,CMPSN:18 OHM,5%,0.125W	01121	BB1805
R4463	321-0170-00			RES.,FXD,FILM:576 OHM,1%,0.125W	91637	MFF1816G576ROF
R4464	317-0180-00			RES.,FXD,CMPSN:18 OHM,5%,0.125W	01121	BB1805
R4465	321-0174-00	B010100	B010129	RES.,FXD,FILM:634 OHM,1%,0.125W	91637	MFF1816G634ROF
R4465	311-0635-00	B010130	B029999	RES.,VAR,NONWIR:1K OHM,10%,0.50W	73138	82-32-0
R4465	311-0633-00	B030000		RES.,VAR,NONWIR:5K OHM,10%,0.50W	73138	82-30-0
R4467	323-0126-00			RES.,FXD,FILM:200 OHM,1%,0.50W	75042	CECT0-2000F
R4469	323-0126-00			RES.,FXD,FILM:200 OHM,1%,0.50W	75042	CECT0-2000F
R4470	321-0239-00			RES.,FXD,FILM:3.01K OHM,1%,0.125W	91637	MFF1816G30100F
R4471	321-0277-00			RES.,FXD,FILM:7.5K OHM,1%,0.125W	91637	MFF1816G75000F
R4473	315-0752-00			RES.,FXD,CMPSN:7.5K OHM,5%,0.25W	01121	CB7525
R4475	321-0206-00			RES.,FXD,FILM:1.37K OHM,1%,0.125W	91637	MFF1816G13700F
R4477	321-0274-00			RES.,FXD,FILM:6.98K OHM,1%,0.125W	91637	MFF1816G69800F
R4479	321-0223-00			RES.,FXD,FILM:2.05K OHM,1%,0.125W	91637	MFF1816G20500F
R4481	321-0122-00			RES.,FXD,FILM:182 OHM,1%,0.125W	91637	MFF1816G182ROF
R4485	321-0122-00			RES.,FXD,FILM:182 OHM,1%,0.125W	91637	MFF1816G182ROF
R4487	321-0196-00			RES.,FXD,FILM:1.07K OHM,1%,0.125W	91637	MFF1816G10700F
R4491	321-0288-00			RES.,FXD,FILM:9.76K OHM,1%,0.125W	91637	MFF1816G97600F
R4493	311-0634-00			RES.,VAR,NONWIR:500 OHM,10%,0.50W	73138	82-31-0
R4495	321-0256-00			RES.,FXD,FILM:4.53K OHM,1%,0.125W	91637	MFF1816G45300F
R4497	321-0161-00			RES.,FXD,FILM:464 OHM,1%,0.125W	91637	MFF1816G464ROF
R4499	321-0161-00			RES.,FXD,FILM:464 OHM,1%,0.125W	91637	MFF1816G464ROF
R5000	311-0546-00			RES.,VAR,NONWIR:10K OHM,20%,0.75W	80009	311-0546-00
R5001	311-0397-01	B010100	B039999	RES.,VAR,NONWIR:2M OHM,10%,0.50W	71590	BA147-044UV3
R5001	311-0254-00	B040000		RES.,VAR,NONWIR:5M OHM,10%,1W	12697	CM29709
R5002	311-0467-00			RES.,VAR,NONWIR:100K OHM,20%,0.50W	11237	300SF-41334
R5003	311-0964-00			RES.,VAR,WW:2.5K OHM,10%	71590	BAS105-036
R5004	311-0310-00			RES.,VAR,NONWIR:5K OHM,20%,0.50W	01121	W-7350A
R5005	315-0471-00			RES.,FXD,CMPSN:470 OHM,5%,0.25W	01121	CB4715
R5006 ¹	311-1104-00			RES.,VAR,NONWIR:10K OHM,10%,0.50W	12697	381-CM40095
R5007	301-0825-00	XB040000		RES.,FXD,CMPSN:8.2M OHM,5%,0.50W	01121	EB8255
R5012 ²	307-0292-XX			RESISTOR:THICK FILM	80009	307-0292-XX
R5013 ²	307-0292-XX			RESISTOR:THICK FILM	80009	307-0292-XX
R5020	301-0271-00	B010100	B091620X	RES.,FXD,CMPSN:270 OHM,5%,0.50W	01121	EB2715
R5022	301-0271-00	B010100	B091620X	RES.,FXD,CMPSN:270 OHM,5%,0.50W	01121	EB2715
R32110	315-0472-00			RES.,FXD,CMPSN:4.7K OHM,5%,0.25W	01121	CB4725
R32115	316-0222-00	B010100	B059999	RES.,FXD,CMPSN:2.2K OHM,10%,0.25W	01121	CB2221
R32115	315-0222-00	B060000		RES.,FXD,CMPSN:2.2K OHM,5%,0.25W	01121	CB2225
R32117	315-0124-00			RES.,FXD,CMPSN:120K OHM,5%,0.25W	01121	CB1245
R32119	316-0471-00	B010100	B059999	RES.,FXD,CMPSN:470 OHM,10%,0.25W	01121	CB4711
R32119	315-0471-00	B060000		RES.,FXD,CMPSN:470 OHM,5%,0.25W	01121	CB4715
R32121	316-0393-00	B010100	B059999	RES.,FXD,CMPSN:39K OHM,10%,0.25W	01121	CB3931
R32121	315-0393-00	B060000		RES.,FXD,CMPSN:39K OHM,5%,0.25W	01121	CB3935
R32125	323-0264-00			RES.,FXD,FILM:5.49K OHM,1%,0.50W	91637	MFF1226G54900F

¹Furnished as a unit with S5006.

²R5012 and R5013, Thick Film Hybrid resistors, are part of the CRT Assembly and are selected at the Factory to match the impedance of the CRT Vertical Deflection Plates. Order the Tektronix P/N printed on the resistors.

Ckt No.	Tektronix Part No.	Serial/Model No. Eff	Dscont	Name & Description	Mfr Code	Mfr Part Number
R32127	316-0562-00	B010100	B059999	RES.,FXD,CMPSN:5.6K OHM,10%,0.25W	01121	CB5621
R32127	315-0562-00	B060000		RES.,FXD,CMPSN:5.6K OHM,5%,0.25W	01121	CB5625
R32130	316-0224-00	B010100	B059999	RES.,FXD,CMPSN:220K OHM,10%,0.25W	01121	CB2241
R32130	315-0224-00	B060000		RES.,FXD,CMPSN:220K OHM,5%,0.25W	01121	CB2245
R32132	321-0272-00			RES.,FXD,FILM:6.65K OHM,1%,0.125W	91637	MFF1816G66500F
R32133	311-1237-00			RES.,VAR,NONWIR:1K OHM,10%,0.50W	32997	3386X-T07-102
R32134	321-0338-00			RES.,FXD,FILM:32.4K OHM,1%,0.125W	91637	MFF1816G32401F
R32137	301-0123-00			RES.,FXD,CMPSN:12K OHM,5%,0.50W	01121	EB1235
R32138	315-0101-00			RES.,FXD,CMPSN:100 OHM,5%,0.25W	01121	CB1015
R32139	308-0703-00			RES.,FXD,WW:1.8 OHM,5%,2W	75042	BWH-1R800J
R32140	316-0471-00	B010100	B059999	RES.,FXD,CMPSN:470 OHM,10%,0.25W	01121	CB4711
R32140	315-0471-00	B060000		RES.,FXD,CMPSN:470 OHM,5%,0.25W	01121	CB4715
R32141	316-0222-00	B010100	B059999	RES.,FXD,CMPSN:2.2K OHM,10%,0.25W	01121	CB2221
R32141	315-0222-00	B060000		RES.,FXD,CMPSN:2.2K OHM,5%,0.25W	01121	CB2225
R32143	316-0331-00	B010100	B059999	RES.,FXD,CMPSN:330 OHM,10%,0.25W	01121	CB3311
R32143	315-0331-00	B060000		RES.,FXD,CMPSN:330 OHM,5%,0.25W	01121	CB3315
R32145	301-0123-00			RES.,FXD,CMPSN:12K OHM,5%,0.50W	01121	EB1235
R41101	315-0131-00			RES.,FXD,CMPSN:130 OHM,5%,0.25W	01121	CB1315
R41103	303-0471-00			RES.,FXD,CMPSN:470 OHM,5%,1W	01121	GB4715
R41105	315-0470-00			RES.,FXD,CMPSN:47 OHM,5%,0.25W	01121	CB4705
R41107	315-0102-00			RES.,FXD,CMPSN:1K OHM,5%,0.25W	01121	CB1025
R41109	323-0309-00	B010100	B189999	RES.,FXD,FILM:16.2K OHM,1%,0.50W	75042	CECT0-1622F
R41109	323-0315-00	B190000		RES.,FXD,FILM:18.7K OHM,1%,0.50W	75042	CECT0-1872F
R41111	315-0473-00			RES.,FXD,CMPSN:47K OHM,5%,0.25W	01121	CB4735
R41113	315-0620-00			RES.,FXD,CMPSN:62 OHM,5%,0.25W	01121	CB6205
R41115	303-0153-00			RES.,FXD,CMPSN:15K OHM,5%,1W	01121	GB1535
R41119	301-0101-00	B010100	B199999	RES.,FXD,CMPSN:100 OHM,5%,0.50W	01121	EB1015
R41119	315-0101-00	B200000		RES.,FXD,CMPSN:100 OHM,5%,0.25W	01121	CB1015
R41120	308-0349-00	B010100	B199999	RES.,FXD,WW:3.6K OHM,1%,3W	91637	RS2B-B36000F
R41120	301-0182-00	B200000		RES.,FXD,CMPSN:1.8K OHM,5%,0.5W	01121	EB1825
R41121	321-0385-00			RES.,FXD,FILM:100K OHM,1%,0.125W	91637	MFF1816G10002F
R41122	301-0182-00	XB200000		RES.,FXD,CMPSN:1.8K OHM,5%,0.5W	01121	EB1825
R41123	315-0471-00			RES.,FXD,CMPSN:470 OHM,5%,0.25W	01121	CB4715
R41124	321-0349-00			RES.,FXD,FILM:42.2K OHM,1%,0.125W	91637	MFF1816G42201F
R41125	321-0335-00			RES.,FXD,FILM:30.1K OHM,1%,0.125W	91637	MFF1816G30101F
R41126	315-0682-00			RES.,FXD,CMPSN:6.8K OHM,5%,0.25W	01121	CB6825
R41127	311-1232-00			RES.,VAR,NONWIR:50K OHM,20%,0.50W	32997	3386F-T04-503
R41129	321-0350-00			RES.,FXD,FILM:43.2K OHM,1%,0.125W	91637	MFF1816G43201F
R41131	307-0272-00			RES.,FXD,COMP:130K OHM,1%,0.25W	80009	307-0272-00
R41133	315-0821-00	B010100	B109999	RES.,FXD,CMPSN:820 OHM,5%,0.25W	01121	CB8215
R41133	315-0101-00	B110000		RES.,FXD,CMPSN:100 OHM,5%,0.25W	01121	CB1015
R41137	315-0332-00			RES.,FXD,CMPSN:3.3K OHM,5%,0.25W	01121	CB3325
R41150	315-0181-00			RES.,FXD,CMPSN:180 OHM,5%,0.25W	01121	CB1815
R41151	303-0123-00			RES.,FXD,CMPSN:12K OHM,5%,1W	01121	GB1235
R41153	301-0562-00			RES.,FXD,CMPSN:5.6K OHM,5%,0.50W	01121	EB5625
R41154	315-0151-00	XB110000		RES.,FXD,CMPSN:150 OHM,5%,0.25W	01121	CB1515
R41155	315-0154-00			RES.,FXD,CMPSN:150K OHM,5%,0.25W	01121	CB1545
R41161	315-0102-00			RES.,FXD,CMPSN:1K OHM,5%,0.25W	01121	CB1025
R41171	311-1235-00			RES.,VAR,NONWIR:100K OHM,20%,0.50W	32997	3386F-T04-104
R41173	311-1227-00			RES.,VAR,NONWIR:5K OHM,20%,0.50W	32997	3386F-T04-502
R41175	321-0303-00	B010100	B069999	RES.,FXD,FILM:14K OHM,1%,0.125W	91637	MFF1816G14001F
R41175	321-0299-00	B070000		RES.,FXD,FILM:12.7K OHM,1%,0.125W	91637	MFF1816G12701F
R41176	311-1466-00	XB070000		RES.,VAR,NONWIR:2K OHM,20%,0.50W	01121	E2B202

Replaceable Electrical Parts—7704A

Ckt No.	Tektronix Part No.	Serial/Model No. Eff	Dscont	Name & Description	Mfr Code	Mfr Part Number
R41177	321-0343-00	B010100	B069999	RES.,FXD,FILM:36.5K OHM,1%,0.125W	91637	MFF1816G36501F
R41177	321-0342-00	B070000		RES.,FXD,FILM:35.7K OHM,1%,0.125W	91637	MFF1816G35701F
R41181	315-0152-00			RES.,FXD,CMPSN:1.5K OHM,5%,0.25W	01121	CB1525
R41185	315-0104-00			RES.,FXD,CMPSN:100K OHM,5%,0.25W	01121	CB1045
RT2315	307-0124-00	B010100	B079999X	RES.,THERMAL:5K OHM,10%	50157	1D1618
RT2325	307-0124-00	B010100	B079999X	RES.,THERMAL:5K OHM,10%	50157	1D1618
RT3009	307-0350-00			RES.,THERMAL:7.5 OHM,10%,3.9%/DEG C	15454	75DJ7R5R0220SS
RT4313	307-0127-00			RES.,THERMAL:1K OHM,10%	50157	2D1596
RT4438	307-0125-00			RES.,THERMAL:500 OHM,10%,25 DEG C	50157	2D1595
S110 ¹	670-1877-00			SWITCH:PUSHBUTTON, VERTICAL MODE	80009	670-1877-00
S120 ¹	670-1878-00			SWITCH:PUSHBUTTON, HORIZONTAL MODE	80009	670-1878-00
S130 ¹	670-1876-00			SWITCH:PUSHBUTTON, A TRIGGER SOURCE	80009	670-1876-00
S140 ¹	670-1876-00			SWITCH:PUSHBUTTON, B TRIGGER SOURCE	80009	670-1876-00
S2510	260-0723-00			SWITCH,SLIDE:DPDT,0.5A,125VAC	79727	GF126-0028
S3320	260-0723-00			SWITCH,SLIDE:DPDT,0.5A,125VAC	79727	GF126-0028
S3340	260-0984-00			SWITCH,SLIDE:DP 3 POSN,0.5A,125VAC-DC	79727	G-228SPC/2140
S3368	260-0723-00			SWITCH,SLIDE:DPDT,0.5A,125VAC	79727	GF126-0028
S5001	260-0449-00			SWITCH,SLIDE:SPDT,0.5A,125VA-DC	82389	11A-1030A
S5006 ²	XXX-XXXX-XX			SWITCH:READOUT		
S5007A,B	260-0688-00			SWITCH,PUSH:DPDT,1A,120VAC	82389	12S1025D
S5020 ³	260-1222-00			SWITCH,PUSH-PUL:10A,250VAC	91929	2DM301
S5022						
T2279	120-0444-00			XFMR,TOROID:5 TURNS,BIFILAR	80009	120-0444-00
T3001	120-0636-00			XFMR,PWR,STPDN:PRI 2.625V,SEC IV,0.005A	80009	120-0636-00
T3025	120-0743-00			XFMR,TOROID:13 TURNS,BIFILAR	80009	120-0743-00
T3030	120-0744-00			XFMR,TOROID:5 WINDINGS	80009	120-0744-00
T3035	120-0747-00			XFMR,TOROID:55 TURNS,SINGLE	80009	120-0747-00
T3101	120-0763-00			TRANSFORMER:POWER	80009	120-0763-00
T4201	120-0762-00			TRANSFORMER:POWER HIGH VOLTAGE	80009	120-0762-00
U1010	156-0038-00			MICROCIRCUIT,DI:J-K MASTER SLAVE FLIP-FLOP	80009	156-0038-00
U2030	155-0015-01			MICROCIRCUIT,DI:ML,ANALOG DATA SWITCH	80009	155-0015-01
U2070	155-0015-01			MICROCIRCUIT,DI:ML,ANALOG DATA SWITCH	80009	155-0015-01
U2210	155-0022-00			MICROCIRCUIT,DI:ML,CHANNEL SWITCH	80009	155-0022-00
U2230	155-0022-00			MICROCIRCUIT,DI:ML,CHANNEL SWITCH	80009	155-0022-00
U2320	155-0022-00			MICROCIRCUIT,DI:ML,CHANNEL SWITCH	80009	155-0022-00
U2404	155-0022-00			MICROCIRCUIT,DI:ML,CHANNEL SWITCH	80009	155-0022-00
U2424	155-0022-00			MICROCIRCUIT,DI:ML,CHANNEL SWITCH	80009	155-0022-00
U2510	155-0011-00			MICROCIRCUIT,DI:ML,CLOCK AND CHOP BLANKING	80009	155-0011-00
U2520	155-0010-00			MICROCIRCUIT,DI:ML,CHOP DIVIDER/BLANKING	80009	155-0010-00
U2530	155-0013-00			MICROCIRCUIT,DI:ML,HORIZ CHOP ALTN BINARY	80009	155-0013-00
U2535	155-0013-00			MICROCIRCUIT,DI:ML,HORIZ CHOP ALTN BINARY	80009	155-0013-00
U2540	155-0013-00			MICROCIRCUIT,DI:ML,HORIZ CHOP ALTN BINARY	80009	155-0013-00
U2573	155-0009-00			MICROCIRCUIT,DI:ML,HORIZ LOCKOUT LOGIC	80009	155-0009-00
U2587	155-0012-00			MICROCIRCUIT,LI:ML,Z-AXIS AND AMPLIFIER	80009	155-0012-00
U3105	155-0067-02			MICROCIRCUIT,DI:ML,POWER SUPPLY REGULATOR	80009	155-0067-02
U3401	155-0018-00			MICROCIRCUIT,DI:ZERO LOGIC	80009	155-0018-00
U3418	155-0014-01			MICROCIRCUIT,DI:ML,ANALOG TO DECIMAL CONV	80009	155-0014-01
U3429	155-0014-01			MICROCIRCUIT,DI:ML,ANALOG TO DECIMAL CONV	80009	155-0014-01
U3433	155-0021-00	B010100	B102079	MICROCIRCUIT,DI:ML,TIMING GENERATOR	80009	155-0021-00
U3433	155-0021-01	B102080		MICROCIRCUIT,DI:ML,TIMING GENERATOR	80009	155-0021-01
U3447	156-0043-00			MICROCIRCUIT,DI:QUAD 2-INPUT POS NOR GATE	80009	156-0043-00
U3449	156-0043-00			MICROCIRCUIT,DI:QUAD 2-INPUT POS NOR GATE	80009	156-0043-00

¹ See Mechanical Parts List for replacement parts.

² Furnished as a unit with R5006.

³ See Mechanical Parts List, Line Voltage Selector.

Ckt No.	Tektronix Part No.	Serial/Model No. Eff	Dscont	Name & Description	Mfr Code	Mfr Part Number
U3450	156-0032-00			MICROCIRCUIT,DI:4-BIT BINARY COUNTER	01295	SN7493AN
U3461	155-0023-00			MICROCIRCUIT,DI:ML,CHAR GEN NUMERALS	80009	155-0023-00
U3463	155-0024-00			MICROCIRCUIT,DI:ML,CHAR GEN SPCL SYMBOLS	80009	155-0024-00
U3465	155-0025-00			MICROCIRCUIT,DI:ML,CHAR GEN PREFIXES	80009	155-0025-00
U3467	155-0026-00			MICROCIRCUIT,DI:ML,CHAR GEN LETTERS	80009	155-0026-00
U3469	155-0027-00			MICROCIRCUIT,DI:ML,CHAR GEN SPCL ALPHA	80009	155-0027-00
U3470	155-0019-00			MICROCIRCUIT,DI:ML,DECIMAL POINT AND SPACE	80009	155-0019-00
U3480	155-0020-00			MICROCIRCUIT,DI:ML,CHANNEL SW OUTPUT ASSY	80009	155-0020-00
U4110	156-0067-00			MICROCIRCUIT,LI:OPERATIONAL AMPLIFIER	80009	156-0067-00
U4214	152-0493-00			SEMICONV DEVICE:3KV P-P IN,+1.2KV OUT	80009	152-0493-00
U4413	155-0077-00			MICROCIRCUIT,LI:HYBRID	80009	155-0077-00
V5050	154-0644-05			ELECTRON TUBE:CRT,P31 PHOSPHOR	80009	154-0644-05
VR3059	152-0287-05	B010100	B099999	SEMICONV DEVICE:ZENER,0.4W,110V,5%	04713	1N986B
VR3059	152-0428-00	B100000		SEMICONV DEVICE:ZENER,0.4W,120V,5%	04713	1N987B
VR3105	152-0243-00			SEMICONV DEVICE:ZENER,0.4W,15V,5%	80009	152-0243-00
VR3129	152-0243-00	B010100	B059999	SEMICONV DEVICE:ZENER,0.4W,15V,5%	80009	152-0243-00
VR3129	152-0304-00	B060000		SEMICONV DEVICE:ZENER,0.4W,20V,5%	04713	1N968B
VR3147	152-0212-00			SEMICONV DEVICE:ZENER,0.5W,9V,5%	80009	152-0212-00
VR3201	152-0226-00			SEMICONV DEVICE:ZENER,0.4W,5.1V,5%	81483	69-6584
VR3271	152-0226-00			SEMICONV DEVICE:ZENER,0.4W,5.1V,5%	81483	69-6584
VR3470	152-0405-00			SEMICONV DEVICE:ZENER,1W,15V,5%	80009	152-0405-00
VR3471	152-0405-00			SEMICONV DEVICE:ZENER,1W,15V,5%	80009	152-0405-00
VR3472	152-0405-00			SEMICONV DEVICE:ZENER,1W,15V,5%	80009	152-0405-00
VR4142	152-0395-00	XB150000		SEMICONV DEVICE:ZENER,0.4W,4.3V,5%	04713	1N749A
VR4175	152-0175-00			SEMICONV DEVICE:ZENER,0.4W,5.6V,5%	80009	152-0175-00
VR32121	152-0127-00			SEMICONV DEVICE:ZENER,0.4W,7.5V,5%	04713	1N958B
VR32127	152-0212-00			SEMICONV DEVICE:ZENER,0.5W,9V,5%	80009	152-0212-00
VR41111	152-0166-00			SEMICONV DEVICE:ZENER,0.4W,6.2V,5%	81483	69-9035
VR41120	152-0087-00	B010100	B199999	SEMICONV DEVICE:ZENER,1W,100V,5%	04713	SZ1627
VR41120	152-0150-00	B200000		SEMICONV DEVICE:ZENER,0.75W,5% 51V	80009	152-0150-00
VR41121	152-0282-00			SEMICONV DEVICE:ZENER,0.4W,30V,5%	04713	1N972B

REPLACEABLE MECHANICAL PARTS

PARTS ORDERING INFORMATION

Replacement parts are available from or through your local Tektronix, Inc. Field Office or representative.

Changes to Tektronix instruments are sometimes made to accommodate improved components as they become available, and to give you the benefit of the latest circuit improvements developed in our engineering department. It is therefore important, when ordering parts, to include the following information in your order: Part number, instrument type or number, serial number, and modification number if applicable.

If a part you have ordered has been replaced with a new or improved part, your local Tektronix, Inc. Field Office or representative will contact you concerning any change in part number.

Change information, if any, is located at the rear of this manual.

SPECIAL NOTES AND SYMBOLS

X000 Part first added at this serial number
00X Part removed after this serial number

FIGURE AND INDEX NUMBERS

Items in this section are referenced by figure and index numbers to the illustrations.

INDENTATION SYSTEM

This mechanical parts list is indented to indicate item relationships. Following is an example of the indentation system used in the description column.

```

1 2 3 4 5           Name & Description
Assembly and/or Component
Attaching parts for Assembly and/or Component
    --- * ---
Detail Part of Assembly and/or Component
Attaching parts for Detail Part
    --- * ---
Parts of Detail Part
Attaching parts for Parts of Detail Part
    --- * ---

```

Attaching Parts always appear in the same indentation as the item it mounts, while the detail parts are indented to the right. Indented items are part of, and included with, the next higher indentation. The separation symbol --- * --- indicates the end of attaching parts.

Attaching parts must be purchased separately, unless otherwise specified.

ITEM NAME

In the Parts List, an Item Name is separated from the description by a colon (:). Because of space limitations, an Item Name may sometimes appear as incomplete. For further Item Name identification, the U.S. Federal Cataloging Handbook H6-1 can be utilized where possible.

ABBREVIATIONS

"	INCH	ELCTRN	ELECTRON	IN	INCH	SE	SINGLE END
#	NUMBER SIZE	ELEC	ELECTRICAL	INCAND	INCANDESCENT	SECT	SECTION
ACTR	ACTUATOR	ELCTLT	ELECTROLYTIC	INSUL	INSULATOR	SEMICON	SEMICONDUCTOR
ADPTR	ADAPTER	ELEM	ELEMENT	INTL	INTERNAL	SHLD	SHIELD
ALIGN	ALIGNMENT	EPL	ELECTRICAL PARTS LIST	LPHLDR	LAMPHOLDER	SHLDR	SHOULDERED
AL	ALUMINUM	EQPT	EQUIPMENT	MACH	MACHINE	SKT	SOCKET
ASSEM	ASSEMBLED	EXT	EXTERNAL	MECH	MECHANICAL	SL	SLIDE
ASSY	ASSEMBLY	FIL	FILLISTER HEAD	MTG	MOUNTING	SLFLKG	SELF-LOCKING
ATTEN	ATTENUATOR	FLEX	FLEXIBLE	NIP	NIPPLE	SLVG	SLEEVING
AWG	AMERICAN WIRE GAGE	FLH	FLAT HEAD	NON WIRE	NOT WIRE WOUND	SPR	SPRING
BD	BOARD	FLTR	FILTER	OB	ORDER BY DESCRIPTION	SQ	SQUARE
BRKT	BRACKET	FR	FRAME or FRONT	OD	OUTSIDE DIAMETER	SST	STAINLESS STEEL
BR	BRASS	FSTNR	FASTENER	OVH	OVAL HEAD	STL	STEEL
BRZ	BRONZE	FT	FOOT	PH BRZ	PHOSPHOR BRONZE	SW	SWITCH
BSHG	BUSHING	FXD	FIXED	PL	PLAIN or PLATE	T	TUBE
CAB	CABINET	GSKT	GASKET	PLSTC	PLASTIC	TERM	TERMINAL
CAP	CAPACITOR	HDL	HANDLE	PN	PART NUMBER	THD	THREAD
CER	CERAMIC	HEX	HEXAGON	PNH	PAN HEAD	THK	THICK
CHAS	CHASSIS	HEX HD	HEXAGONAL HEAD	PWR	POWER	TNSN	TENSION
CKT	CIRCUIT	HEX SOC	HEXAGONAL SOCKET	RCPT	RECEPTACLE	TPG	TAPPING
COMP	COMPOSITION	HLCPS	HELICAL COMPRESSION	RES	RESISTOR	TRH	TRUSS HEAD
CONN	CONNECTOR	HLEXT	HELICAL EXTENSION	RGD	RIGID	V	VOLTAGE
COV	COVER	HV	HIGH VOLTAGE	RLF	RELIEF	VAR	VARIABLE
CPLG	COUPLING	IC	INTEGRATED CIRCUIT	RTNR	RETAINER	W/	WITH
CRT	CATHODE RAY TUBE	ID	INSIDE DIAMETER	SCH	SOCKET HEAD	WSHR	WASHER
DEG	DEGREE	IDENT	IDENTIFICATION	SCOPE	OSCILLOSCOPE	XFMR	TRANSFORMER
DWR	DRAWER	IMPLR	IMPELLER	SCR	SCREW	XSTR	TRANSISTOR

CROSS INDEX—MFR. CODE NUMBER TO MANUFACTURER

Mfr. Code	Manufacturer	Address	City, State, Zip
00779	AMP, INC.	P O BOX 3608	HARRISBURG, PA 17105
01295	TEXAS INSTRUMENTS, INC., SEMICONDUCTOR GROUP	P O BOX 5012, 13500 N CENTRAL EXPRESSWAY	DALLAS, TX 75222
04713	MOTOROLA, INC., SEMICONDUCTOR PROD. DIV.	5005 E MCDOWELL RD, PO BOX 20923	PHOENIX, AZ 85036
05091	TRI-ORDINATE CORPORATION	343 SNYDER AVENUE	BERKELEY HEIGHTS, NJ 07922
07700	TECHNICAL WIRE AND PRODUCTS, INC.	129 DERMODY ST.	CRANFORD, NJ 07016
08261	SPECTRA-STRIP CORP.	7100 LAMPSON AVE.	GARDEN GROVE, CA 92642
09422	PLASTIC STAMPING CORPORATION	2216 W. ARMITAGE AVE.	CHICAGO, IL 60647
12014	CHICAGO RIVET AND MACHINE CO.	950 S. 25TH AVENUE	BELLWOOD, IL 60104
12327	FREEWAY CORPORATION	9301 ALLEN DRIVE	CLEVELAND, OH 44125
22526	BERG ELECTRONICS, INC.	YOUK EXPRESSWAY	NEW CUMBERLAND, PA 17070
26365	GRIES REPRODUCER CO., DIV. OF COATS AND CLARK, INC.	125 BEECHWOOD AVE.	NEW ROCHELLE, NY 10802
55210	GETTIG ENG. AND MFG. COMPANY	PO BOX 85, OFF ROUTE 45	SPRING MILLS, PA 16875
70485	ATLANTIC INDIA RUBBER WORKS, INC.	571 W. POLK ST.	CHICAGO, IL 60607
71159	BRISTOL SOCKET SCREW, DIV. OF AMERICAN CHAIN AND CABLE CO., INC.	P O BOX 2244, 40 BRISTOL ST.	WATERBURY, CT 06720
71279	CAMBRIDGE THERMIONIC CORP.	445 CONCORD AVE.	CAMBRIDGE, MA 02138
71286	REXNORD, INC., SPECIALTY FASTENER DIV.	22 SPRING VALLEY RD.	PARAMUS, NJ 07652
71785	TRW, CINCH CONNECTORS	1501 MORSE AVENUE	ELK GROVE VILLAGE, IL 60007
73743	FISCHER SPECIAL MFG. CO.	446 MORGAN ST.	CINCINNATI, OH 45206
73803	TEXAS INSTRUMENTS, INC., METALLURGICAL MATERIALS DIV.	34 FOREST STREET	ATTLEBORO, MA 02703
74445	HOLO-KROME CO.	31 BROOK ST. WEST	HARTFORD, CT 06110
78189	ILLINOIS TOOL WORKS, INC. SHAKEPROOF DIVISION	ST. CHARLES ROAD	ELGIN, IL 60120
79727	C-W INDUSTRIES	550 DAVISVILLE RD., P O BOX 96	WARMINISTER, PA 18974
79807	WROUGHT WASHER MFG. CO.	2100 S. O BAY ST.	MILWAUKEE, WI 53207
80009	TEKTRONIX, INC.	P O BOX 500	BEAVERTON, OR 97077
80033	PRESTOLE EVERLOCK, INC.	P. O. BOX 278, 1345 MIAMI ST.	TOLEDO, OH 43605
82389	SWITCHCRAFT, INC.	5555 N. ELSTON AVE.	CHICAGO, IL 60630
83385	CENTRAL SCREW CO.	2530 CRESCENT DR.	BROADVIEW, IL 60153
86928	SEASTROM MFG. COMPANY, INC.	701 SONORA AVENUE	GLENDALE, CA 91201
87308	N. L. INDUSTRIES, INC., SOUTHERN SCREW DIV.	P. O. BOX 1360	STATESVILLE, NC 28677
91929	HONEYWELL, INC., MICRO SWITCH DIV.	CHICAGO & SPRING STS.	FREEPORT, IL 61032
95238	CONTINENTAL CONNECTOR CORP.	34-63 56TH ST.	WOODSIDE, NY 11377
98159	RUBBER TECK, INC.	19115 HAMILTON AVE., P O BOX 389	GARDENA, CA 90247

FIGURE 1 D7704

Fig. & Index No.	Tektronix Part No.	Serial/Model No. Eff Dscont	Qty	1 2 3 4 5	Name & Description	Mfr Code	Mfr Part Number
1-1	426-0514-00		1		FRAME, MASK: PLASTIC	80009	426-0514-00
-2	337-1159-00		1		WINDOW, OBS: 4.78 X 3.93 X 0.07" PLSTC	80009	337-1159-00
-3	331-0258-03		1		MASK, CRT SCALE:	80009	331-0258-03
-4	200-0939-01		1		BEZEL, CRT:	80009	200-0939-01
-5	212-0023-00	B010100 B132652	4		SCREW, MACHINE: 8-32 X 0.375 INCH, PNH STL	83385	OBD
	212-0008-00	B132653	4		SCREW, MACHINE: 8-32 X 0.500 INCH, PNH STL	83385	OBD
-6	204-0380-00		1		BODY, TERMINAL:	80009	204-0380-00
-7	131-0765-00		3		CONTACT, ELEC:	80009	131-0765-00
-8	378-0625-00		1		FILTER, LT, CRT:	80009	378-0625-00
-9	331-0245-00		1		MASK, CRT SCALE:	80009	331-0245-00
-10	366-0494-00		1		KNOB: GRAY	80009	366-0494-00
	213-0153-00		1		. SETSCREW: 5-40 X 0.125 INCH, HEX SOC STL	74445	OBD
-11	366-0494-00		1		KNOB: GRAY	80009	366-0494-00
	213-0153-00		1		. SETSCREW: 5-40 X 0.125 INCH, HEX SOC STL	74445	OBD
-12	366-0494-00		1		KNOB: GRAY	80009	366-0494-00
	213-0153-00		1		. SETSCREW: 5-40 X 0.125 INCH, HEX SOC STL	74445	OBD
-13	366-0494-00		1		KNOB: GRAY	80009	366-0494-00
	213-0153-00		1		. SETSCREW: 5-40 X 0.125 INCH, HEX SOC STL	74445	OBD
-14	358-0301-02		2		BUSHING, SLEEVE: GRAY PLASTIC	80009	358-0301-02
-15	-----		1		CKT BOARD ASSY: GRATICULE LIGHT (SEE A50 EPL)		
-16	378-0614-00		1		. REFLECTOR, LIGHT: MOLDED PLASTIC	80009	378-0614-00
-17	211-0062-00		2		. SCREW, MACHINE: 2-56 X 0.312 INCH, RDH STL	83385	OBD
-18	344-0179-00		2		. CLIP, REFL FRNG: PLASTIC	80009	344-0179-00
-19	333-1492-00		1		PANEL, FRONT: D7704	80009	333-1491-00
	200-0103-00	XB130000	1		NUT, PLAIN, KNURL: 0.25-28 X 0.375" OD, BRASS	80009	200-0103-00
	355-0507-00	XB130000	1		STUD, SHOULDERED: BINDING POST (ATTACHING PARTS)	80009	355-0507-00
	210-0583-00	XB130000	1		NUT, PLAIN, HEX.: 0.25-32 X 0.312 INCH, BRS	73743	2X20224-402
	210-0046-00	XB130000	1		WASHER, LOCK: INTL, 0.26 ID X 0.40" OD, STL - - - * - - -	78189	1214-05-00-0541C
-20	-----		1		RESISTOR: VARIABLE (SEE R5002 EPL) (ATTACHING PARTS)		
-21	358-0409-00		1		BSHG, MACH. THD: 0.25-32 X 0.159 ID X 0.24	80009	358-0409-00
-22	210-0046-00		1		WASHER, LOCK: INTL, 0.26 ID X 0.40" OD, STL	78189	1214-05-00-0541C
-23	210-0471-00		1		NUT, SLEEVE: HEX., 0.312 X 0.594 INCH LONG - - - * - - -	80009	210-0471-00
-24	200-0608-00		1		COVER, VAR RES.: PLASTIC	80009	200-0608-00
-25	-----		1		RESISTOR: VARIABLE (SEE R5001 EPL) (ATTACHING PARTS)		
-26	210-0583-00		1		NUT, PLAIN, HEX.: 0.25-32 X 0.312 INCH, BRS	73743	2X20224-402
-27	210-0046-00		1		WASHER, LOCK: INTL, 0.26 ID X 0.40" OD, STL	78189	1214-05-00-0541C
	210-0940-00		1		WASHER, FLAT: 0.25 ID X 0.375 INCH OD, STL - - - * - - -	79807	OBD
-28	260-0688-00		1		SWITCH, PUSH: DPDT, 1A, 120VAC (ATTACHING PARTS)	82389	12S1025D
-29	210-0583-00		2		NUT, PLAIN, HEX.: 0.25-32 X 0.312 INCH, BRS	73743	2X20224-402
	210-0940-00		1		WASHER, FLAT: 0.25 ID X 0.375 INCH OD, STL - - - * - - -	79807	OBD
-30	-----		1		RESISTOR: VARIABLE (SEE R5004 EPL) (ATTACHING PARTS)		
-31	210-0583-00		2		NUT, PLAIN, HEX.: 0.25-32 X 0.312 INCH, BRS	73743	2X20224-402
-32	210-0046-00		1		WASHER, LOCK: INTL, 0.26 ID X 0.40" OD, STL - - - * - - -	78189	1214-05-00-0541C
-33	-----		1		RESISTOR: VARIABLE (SEE R5003 EPL) (ATTACHING PARTS)		
-34	358-0409-00		1		BSHG, MACH. THD: 0.25-32 X 0.159 ID X 0.24	80009	358-0409-00
-35	210-0046-00		1		WASHER, LOCK: INTL, 0.26 ID X 0.40" OD, STL	78189	1214-05-00-0541C
-36	210-0471-00		1		NUT, SLEEVE: HEX., 0.312 X 0.594 INCH LONG - - - * - - -	80009	210-0471-00
-37	-----		1		RESISTOR: VARIABLE (SEE R5006 EPL) (ATTACHING PARTS)		
-38	210-0583-00		1		NUT, PLAIN, HEX.: 0.25-32 X 0.312 INCH, BRS	73743	2X20224-402
-39	210-0046-00		1		WASHER, LOCK: INTL, 0.26 ID X 0.40" OD, STL - - - * - - -	78189	1214-05-00-0541C

Replaceable Mechanical Parts—7704A

FIGURE 1 D7704 (CONT)

Fig. & Index No.	Tektronix Part No.	Serial/Model No. Eff Dscont	Qty	1	2	3	4	5	Name & Description	Mfr Code	Mfr Part Number
1-40	-----	-----	1						RESISTOR:VARIABLE (SEE R5000 EPL) (ATTACHING PARTS)		
-41	210-0583-00		2						NUT,PLAIN,HEX.:0.25-32 X 0.312 INCH,BRS	73743	2X20224-402
-42	210-0940-00		1						WASHER,FLAT:0.25 ID X 0.375 INCH OD,STL	79807	OBD
-43	210-0046-00		1						WASHER,LOCK:INTL,0.26 ID X 0.40" OD,STL	78189	1214-05-00-0541C
									- - - * - - - -		
-44	426-0808-01		1						FRAME,PNL,CAB.:FRONT	80009	426-0808-01
-45	386-1517-00		4						. SUPPORT,CRT:	80009	386-1517-00
-46	348-0216-00		1						SHLD GSKT,ELECT:	07700	30-90042
	119-0337-00		1						DELAY LINE,ELEC:	80009	119-0337-00
-47	200-1313-00		1						. COV,DELAY LINE:	80009	200-1313-00
-48	213-0041-00		4						. SCR,TPG,THD CTG:6-32 X 0.375 INCH,TRH STL	83385	OBD
-49	129-0215-00		2						. POST,NONMETALL:1 DIA X 1.063 INCH LONG	80009	129-0215-00
-50	441-1045-00		1						. CHAS,DELAY LINE:	80009	441-1045-00
									(ATTACHING PARTS)		
-51	211-0559-00		1						SCREW,MACHINE:6-32 X 0.375"100 DEG,FLH STL	83385	OBD
-52	210-0457-00		4						NUT,PLAIN,EXT W:6-32 X 0.312 INCH,STL	83385	OBD
	211-0507-00		3						SCREW,MACHINE:6-32 X 0.312 INCH,PNH STL	83385	OBD
-53	210-0202-00		1						TERMINAL,LUG:SE #6	78189	2104-06-00-2520N
									- - - * - - - -		
-54	200-1319-00		1						COVER,CKT:UPPER	80009	200-1319-00
									(ATTACHING PARTS)		
-55	211-0504-00		3						SCREW,MACHINE:6-32 X 0.25 INCH,PNH STL	83385	OBD
									- - - * - - - -		
-56	200-1326-00		1						COVER,CKT:LOWER	80009	200-1326-00
									(ATTACHING PARTS)		
-57	211-0507-00		2						SCREW,MACHINE:6-32 X 0.312 INCH,PNH STL	83385	OBD
-58	210-0457-00		2						NUT,PLAIN,EXT W:6-32 X 0.312 INCH,STL	83385	OBD
-59	211-0504-00		2						SCREW,MACHINE:6-32 X 0.25 INCH,PNH STL	83385	OBD
									- - - * - - - -		
-60	-----	-----	1						CKT BOARD ASSY:HIGH VOLTAGE(SEE A42 EPL)		
-61	131-0589-00		5						. CONTACT,ELEC:0.46 INCH LONG	22526	47350
	131-0608-00		14						. CONTACT,ELEC:0.365L X 0.25 PH BRZ GOLD PL	22526	47357
-62	-----	-----	1						. TRANSFORMER (SEE T4201 EPL) (ATTACHING PARTS)		
-63	211-0008-00		4						. SCREW,MACHINE:4-40 X 0.25 INCH,PNH STL	83385	OBD
									- - - * - - - -		
-64	-----	-----	1						. HIGH VOLTAGE MULTIPLIER (U4214) (ATTACHING PARTS)		
-65	210-0458-00		2						. NUT,PLAIN,EXT W:8-32 X 0.344 INCH,STL	83385	OBD
	210-0804-00		2						. WASHER,FLAT:0.17 ID X 0.375 INCH OD,STL	12327	OBD
									- - - * - - - -		
-66	131-1003-00		4						. CONNECTOR BODY,:CKT CD MT,3 PRONG	80009	131-1003-00
-67	136-0252-04		7						. SOCKET,PIN TERM:0.188 INCH LONG	22526	75060
-68	-----	-----	1						TRANSISTOR (SEE Q4250 EPL) (ATTACHING PARTS)		
-69	211-0012-00		1						. SCREW,MACHINE:4-40 X 0.375 INCH,PNH STL	83385	OBD
-70	210-0921-00		1						. WASHER,MICA:0.50 X 0.141 X 0.005 INCH THK	80009	210-0921-00
									- - - * - - - -		
	131-0566-00	XB110000	1						. LINK,TERM.CONNE:0.086 DIA X 2.375 INCH L	55210	L-2007-1
-71	348-0090-00		1						CUSHION,CRT: (ATTACHING PARTS)	85471	OBD
-72	211-0008-00		4						SCREW,MACHINE:4-40 X 0.25 INCH,PNH STL	83385	OBD
									- - - * - - - -		
-73	129-0304-00		4						INSULATOR,STDF:0.25 OD X 1.23 INCH LONG (ATTACHING PARTS FOR EACH)	80009	129-0304-00
	211-0008-00		1						SCREW,MACHINE:4-40 X 0.25 INCH,PNH STL	83385	OBD
									- - - * - - - -		
-74	129-0349-00		1						POST,ELEC-MECH:0.25 OD X 1.265 INCH LONG (ATTACHING PARTS)	80009	129-0349-00
-75	211-0008-00		1						SCREW,MACHINE:4-40 X 0.25 INCH,PNH STL	83385	OBD
									- - - * - - - -		

FIGURE 1 D7704 (CONT)

Fig. & Index No.	Tektronix Part No.	Serial/Model No. Eff	Dscont	Qty	1	2	3	4	5	Name & Description	Mfr Code	Mfr Part Number
1-76	367-0156-00			1						HANDLE, CONN: (ATTACHING PARTS)	80009	367-0156-00
-77	211-0012-00			2						SCREW, MACHINE: 4-40 X 0.375 INCH, PNH STL	83385	OBD
-78	210-0586-00			2						NUT, PLAIN, EXT W: 4-40 X 0.25 INCH, STL	78189	OBD
										- - - * - - -		
-79	131-1250-00			1						CONNECTOR, RCPT, :60 CONTACT (ATTACHING PARTS)	95238	K60010060WA300
-80	213-0082-00			2						SCR, TPG, THD CTG: 4-40 X 0.50 INCH, PNH STL	80009	213-0082-00
										- - - * - - -		
-81	175-1972-00			1						CA ASSY, SP, ELEC: 50 OHM COAX, UPPER LEFT	80009	175-1972-00
	175-1971-00			1						CA ASSY, SP, ELEC: 50 OHM COAX, UPPER RIGHT	80009	175-1971-00
-82	175-1973-00			1						CA ASSY, SP, ELEC: 50 OHM COAX, LOWER RIGHT	80009	175-1973-00
	175-1974-00			1						CA ASSY, SP, ELEC: 50 OHM COAX, LOWER LEFT	80009	175-1974-00
										(ATTACHING PARTS)		
-83	213-0104-00			2						SCR, TPG, THD FOR: 6-20 X 0.375 INCH, TRH STL	83385	OBD
-84	407-1013-00			1						BRKT, CONN SPRT:	80009	407-1013-00
-85	211-0507-00			2						SCREW, MACHINE: 6-32 X 0.312 INCH, PNH STL	83385	OBD
-86	210-0457-00			2						NUT, PLAIN, EXT W: 6-32 X 0.312 INCH, STL	83385	OBD
										- - - * - - -		
-87	343-0089-00			1						CLAMP, LOOP: LARGE	80009	343-0089-00
-88	-----			1						CKT BOARD ASSY: Z-AXIS (SEE A41 EPL)		
-89	131-0589-00			7						. CONTACT, ELEC: 0.46 INCH LONG	22526	47350
	131-0608-00			32						. CONTACT, ELEC: 0.365 L X 0.25 PH BRZ GOLD PL	22526	47357
-90	131-1003-00			4						. CONNECTOR BODY, :CKT CD MT, 3 PRONG	80009	131-1003-00
-91	136-0252-04	B010100	B112459	69						. SOCKET, PIN TERM: 0.188 INCH LONG	22526	75060
	136-0254-04	B112460	B189999	7						. CONTACT, ELEC: 0.188 INCH LONG	22526	75060
	136-0252-04	B190000		69						. SOCKET, PIN TERM: 0.188 INCH LONG	22526	75060
	136-0183-00	B112460	B189999	18						. SOCKET, PLUG-IN: 3 PIN, ROUND	80009	136-0183-00
	136-0183-00	B190000		12						. SOCKET, PLUG-IN: 3 PIN, ROUND	80009	136-0183-00
	136-0220-00	B112460	B189999X	12						. SOCKET, PLUG-IN: 3 PIN, SQUARE	71785	133-23-11-034
	136-0514-00	B112460	B189999X	1						. SOCKET, PLUG IN: MICROCIRCUIT, 8 CONTACT	73803	C9308-02
-92	214-0579-00			1						. TERM., TEST PT: 0.40 INCH LONG	80009	214-0579-00
										(ATTACHING PARTS)		
-93	211-0008-00			4						SCREW, MACHINE: 4-40 X 0.25 INCH, PNH STL	83385	OBD
										- - - * - - -		
-94	337-1460-00			1						SHLD, ELECTRON T: CRT	80009	337-1460-00
-95	-----			1						COIL (SEE L5007 EPL)		
										(ATTACHING PARTS)		
-96	343-0217-00			1						CLAMP, COIL: Y-AXIS	80009	343-0217-00
-97	213-0138-00			2						SCR, TPG, THD FOR: 4-40 X 0.188 INCH, PNH STL	83385	OBD
										- - - * - - -		
-98	214-0291-00			1						CONTACT, SPRING: 1.188 X 0.375 X 0.25 INCH (ATTACHING PARTS)	80009	214-0291-00
-99	211-0007-00			1						SCREW, MACHINE: 4-40 X 0.188 INCH, PNH STL	83385	OBD
-100	210-0586-00			1						NUT, PLAIN, EXT W: 4-40 X 0.25 INCH, STL	78189	OBD
-101	210-0201-00			1						TERMINAL, LUG: SE #4	78189	2104-04-00-2520N
										- - - * - - -		
-102	348-0055-00			2						GROMMET, PLASTIC: 0.25 INCH DIA	80009	348-0055-00
-103	354-0347-00			1						RING, CLP, CRT RE: (ATTACHING PARTS)	80009	354-0347-00
-104	211-0170-00			2						SCREW, MACHINE: 4-40 X 2.75 INCH, PNH STL	83385	OBD
-105	214-1333-00			2						SPRING, HLCPS: 0.213 OD X 0.375 INCH LONG	80009	214-1333-00
										- - - * - - -		
-106	343-0205-01			1						RTNR, ELECTRON T: (ATTACHING PARTS)	80009	343-0205-01
-107	211-0507-00			4						SCREW, MACHINE: 6-32 X 0.312 INCH, PNH STL	83385	OBD
-108	210-0949-00			4						WASHER, FLAT: 0.141 ID X 0.50 INCH OD, BRS	12327	OBD
										- - - * - - -		
-109	136-0493-00			1						SOCKET, PLUG-IN: CRT	80009	136-0493-00
-110	136-0304-02			1						. SOCKET, PLUG-IN: CRT, 14 PIN SOCKET, W/PINS	80009	136-0304-02
-111	200-0917-01			1						. COV, ELECTRON TU: 2.052 OD X 0.291" THK, PLSTC	80009	200-0917-01
-112	343-0254-00			1						. CLAMP, CRT SKT:	80009	343-0254-00
-113	367-0117-00			1						. PULL, SOC, PL-IN:	80009	367-0117-00
-114	352-0163-00			1						. CONN BODY, PL, EL: 5 WIRE BLACK	80009	352-0163-00

FIGURE 1 D7704 (CONT)

Fig. & Index No.	Tektronix Part No.	Serial/Model No. Eff Dscont	Qty	1	2	3	4	5	Name & Description	Mfr Code	Mfr Part Number
1-115	352-0201-00		1	.					CONN BODY, PL, EL:5 WIRE BLACK	80009	352-0201-00
-116	131-0707-00		5	.					CONTACT, ELEC:0.48" L, 22-26 AWG, WIRE	22526	5999-00-396-6331
-117	131-0621-00		5	.					CONTACT, ELEC:0.577" L, 22-26 AWG WIRE	22526	46233
-118	175-0828-00		IN	.					WIRE, ELECTRICAL:5 WIRE RIBBON	08261	OBD
-119	351-0322-00		1						GUIDE, CKT CARD:	80009	351-0322-00
-120	210-0201-00		1						TERMINAL, LUG:SE #4 (ATTACHING PARTS)	78189	2104-04-00-2520N
-121	211-0007-00		1						SCREW, MACHINE:4-40 X 0.188 INCH, PNH STL	83385	OBD
	210-0586-00		1						NUT, PLAIN, EXT W:4-40 X 0.25 INCH, STL	78189	OBD
-122	-----		1						RESISTOR:THICK FILM (SEE R5012, R5013 EPL) (ATTACHING PARTS)		
-123	211-0510-00		2						SCREW, MACHINE:6-32 X 0.375 INCH, PNH STL	83385	OBD
-124	210-0457-00		2						NUT, PLAIN, EXT W:6-32 X 0.312 INCH, STL	83385	OBD
-125	210-0894-00		2						WASHER, NONMETAL:0.19 ID X 0.438" OD, PLSTC	09422	OBD
-126	210-0202-00		1						TERMINAL, LUG:SE #6 (ATTACHING PARTS)	78189	2104-06-00-2520N
-127	211-0507-00		1						SCREW, MACHINE:6-32 X 0.312 INCH, PNH STL	83385	OBD
-128	210-0457-00		1						NUT, PLAIN, EXT W:6-32 X 0.312 INCH, STL	83385	OBD
-129	-----		1						CKT BOARD ASSY:VERTICAL AMP (SEE A44 EPL)		
-130	131-0608-00		6	.					CONTACT, ELEC:0.365 L X 0.25 PH BRZ GOLD PL	22526	47357
-131	131-1003-00		3	.					CONNECTOR BODY, :CKT CD MT, 3 PRONG	80009	131-1003-00
-132	136-0252-01		14	.					CONTACT, ELEC:0.178 INCH LONG	00779	1-332095-2
	136-0252-04		18	.					SOCKET, PIN TERM:0.188 INCH LONG	22526	75060
-133	214-0579-00		1	.					TERM., TEST PT:0.40 INCH LONG	80009	214-0579-00
-134	346-0097-00		1	.					STRAP, GROUNDING:INTEGRATED CIRCUIT	80009	346-0097-00
-135	-----		1	.					INTEGRATED CIRCUIT (SEE U4413 ELECTRICAL LIST) (ATTACHING PARTS)		
-136	210-0407-00		1						NUT, PLAIN, HEX.:6-32 X 0.25 INCH, BRS	73743	3038-0228-402
-137	210-0907-00		1						WASHER, RING:0.25 INCH OD	71286	5S3-1
-138	211-0008-00		3						SCREW, MACHINE:4-40 X 0.25 INCH, PNH STL	83385	OBD
-139	348-0031-00		3						GROMMET, PLASTIC:0.156 INCH DIA	80009	348-0031-00
-140	134-0119-00		1						PLUG, PLASTIC:0.17 OD X 0.144 INCH LONG	80009	134-0119-00
-141	348-0056-00		1						GROMMET, PLASTIC:0.375 INCH DIA	80009	348-0056-00
-142	441-1044-00		1						CHASSIS, SCOPE:HORIZ VERT CKT (ATTACHING PARTS)	80009	441-1044-00
-143	211-0507-00		4						SCREW, MACHINE:6-32 X 0.312 INCH, PNH STL	83385	OBD
-144	210-0457-00		2						NUT, PLAIN, EXT W:6-32 X 0.312 INCH, STL	83385	OBD
-145	210-0202-00		1						TERMINAL, LUG:SE #6 (ATTACHING PARTS)	78189	2104-06-00-2520N
-146	-----		1						CKT BOARD ASSY:HORIZONTAL AMPLIFIER (SEE A43 EPL)		
-147	131-0608-00		6	.					CONTACT, ELEC:0.365 L X 0.25 PH BRZ GOLD PL	22526	47357
	166-0527-00	XB050000	2	.					SLEEVE, SPACING:0.15 INCH LONG	80009	166-0527-00
-148	131-1003-00		3	.					CONNECTOR BODY, :CKT CD MT, 3 PRONG	80009	131-1003-00
-149	136-0252-04		45	.					SOCKET, PIN TERM:0.188 INCH LONG (ATTACHING PARTS)	22526	75060
-150	211-0008-00		2						SCREW, MACHINE:4-40 X 0.25 INCH, PNH STL	83385	OBD
-151	426-0809-01		1						FRAME PNL, CAB.:REAR	80009	426-0809-01
-152	386-2125-00		1						PANEL, REAR: (ATTACHING PARTS)	80009	386-2125-00
-153	211-0008-00		4						SCREW, MACHINE:4-40 X 0.25 INCH, PNH STL	83385	OBD
-154	426-0815-00		2						FRAME SECT, CAB.:BOTTOM (ATTACHING PARTS FOR EACH)	80009	426-0815-00
-155	213-0270-00		2						SCR, TPG, THD FOR:10-32 X 0.75 INCH FILH STL	83385	OBD
-156	352-0169-00		2						CONN BODY, PL, EL:2 WIRE BLACK	80009	352-0169-00
-157	352-0161-00		1						CONN BODY, PL, EL:3 WIRE BLACK	80009	352-0161-00

FIGURE 2 A7704 FRONT

Fig. & Index No.	Tektronix Part No.	Serial/Model No. Eff	Dscont	Qty	1	2	3	4	5	Name & Description	Mfr Code	Mfr Part Number
2-1	333-1491-00			1	PANEL:FRONT						80009	333-1491-00
					(ATTACHING PARTS)							
-2	213-0055-00			4	SCREW,TPG,THD FOR:2-32 X 0.188 INCH,PNH STL						83385	OBD
					- - - * - - -							
-3	348-0204-00			1	SHLD GSKT,ELECT:					80009	348-0204-00	
-4	384-1122-00			1	EXTENSION SHAFT:POWER SWITCH					80009	384-1122-00	
-5	366-1023-00			1	KNOB:GRAY					80009	366-1023-00	
	213-0246-00			1	. SETSCREW:5-40 X 0.093 INCH L,HEX SOC					71159	OBD	
-6	366-1023-00			1	KNOB:GRAY					80009	366-1023-00	
	213-0246-00			1	. SETSCREW:5-40 X 0.093 INCH L,HEX SOC					71159	OBD	
-7	366-1023-00			1	KNOB:GRAY					80009	366-1023-00	
	213-0246-00			1	. SETSCREW:5-40 X 0.093 INCH L,HEX SOC					71159	OBD	
-8	337-1542-00			1	SHLD GSKT,ELECT:2.10 INCHES LONG					80009	337-1542-00	
-9	337-1543-00			3	SHLD GSKT,ELECT:2.50 INCHES LONG					80009	337-1543-00	
-10	200-0984-00			1	BEZEL:PLASTIC,5 BUTTON SWITCH					80009	200-0984-00	
-11	200-0983-00			1	BEZEL:PLASTIC,4 BUTTON SWITCH					80009	200-0983-00	
-12	426-0806-01			1	FRAME PNL,CAB.:FRONT					80009	426-0806-01	
-13	136-0387-00			3	. JACK,TIP:GRAY					71279	4352-1-0318	
-14	136-0387-01			1	. JACK,TIP:BLACK					71279	450-4352-01-0310	
					(ATTACHING PARTS)							
-15	213-0270-00			4	SCR,TPG,THD FOR:10-32 X 0.75 INCH FILH STL					83385	OBD	
					- - - * - - -							
-16	358-0216-00			1	BUSHING,PLASTIC:0.257 ID X 0.412 INCH OD					80009	358-0216-00	
-17	348-0031-00			3	GROMMET,PLASTIC:0.156 INCH DIA					80009	348-0031-00	
-18	-----			1	CKT BOARD ASSY:VERTICAL MODE(SEE ALL EPL)							
-19	131-0590-00			8	. CONTACT,ELEC:0.71 INCH LONG					22526	47351	
-20	337-1157-00			1	. SHLD,ELECTRICAL:					80009	337-1157-00	
-21	366-1109-01			1	. PUSH BUTTON:LEFT					80009	366-1109-01	
	366-1109-02			1	. PUSH BUTTON:ALT					80009	366-1109-02	
	366-1109-03			1	. PUSH BUTTON:ADD					80009	366-1109-03	
	366-1109-04			1	. PUSH BUTTON:CHOP					80009	366-1109-04	
-22	366-1109-05			1	. PUSH BUTTON:RIGHT					80009	366-1109-05	
-23	380-0147-00			1	. HOUSING,FRONT:					80009	380-0147-00	
					(ATTACHING PARTS)							
-24	211-0125-00			3	. SCREW,MACHINE:1-72 X 0.25 INCH,PNH STL					83385	OBD	
					- - - * - - -							
-25	-----			1	CKT BOARD ASSY:HORIZONTAL MODE(SEE A12 EPL)							
-26	131-0590-00			7	. CONTACT,ELEC:0.71 INCH LONG					22526	47351	
-27	337-1156-00			1	. SHLD,ELECTRICAL:					80009	337-1156-00	
-28	366-1109-06			1	. PUSH BUTTON:A					80009	366-1109-06	
	366-1109-02			1	. PUSH BUTTON:ALT					80009	366-1109-02	
	366-1109-04			1	. PUSH BUTTON:CHOP					80009	366-1109-04	
-29	366-1109-07			1	. PUSH BUTTON:B					80009	366-1109-07	
-30	380-0168-00			1	. HOUSING,FRONT:					80009	380-0168-00	
					(ATTACHING PARTS)							
-31	211-0125-00			3	. SCREW,MACHINE:1-72 X 0.25 INCH,PNH STL					83385	OBD	
					- - - * - - -							
-32	-----			1	CKT BOARD ASSY:A TRIGGER SOURCE(SEE A13 EPL)							
-33	131-0592-00	B010100	B010119	2	. CONTACT,ELEC:0.885 INCH LONG					22526	47353	
	131-0592-00	B010120		3	. CONTACT,ELEC:0.885 INCH LONG					22526	47353	
-34	131-0787-00			5	. CONTACT,ELEC:0.64 INCH LONG					22526	47359	
-35	-----			-	CKT BOARD ASSY:B TRIGGER SOURCE(SEE A14 EPL)							
-36	131-0592-00	B010100	B010119	2	. CONTACT,ELEC:0.885 INCH LONG					22526	47353	
	131-0592-00	B010120		3	. CONTACT,ELEC:0.885 INCH LONG					22526	47353	
-37	131-0787-00			5	. CONTACT,ELEC:0.64 INCH LONG					22526	47359	
-38	166-0099-00			3	POST,ELEC-MECH:0.25 OD X 1.719 INCHES L					80009	166-0099-00	
-39	-----			1	CKT BOARD ASSY:CALIBRATOR(SEE A10 EPL)							
-40	131-0608-00			32	. CONTACT,ELEC:0.365 L X 0.25 PH BRZ GOLD PL					22526	47357	
-41	136-0263-03	B010100	B153439	31	. SOCKET,PIN TERM:FOR 0.025 INCH SQUARE PIN					00779	86250-2	
	136-0263-04	B153440		31	. SOCKET,PIN TERM:FOR 0.025 INCH SQUARE PIN					22526	75377-001	
-42	136-0252-04	B010100	B112459	38	. SOCKET,PIN TERM:0.188 INCH LONG					22526	75060	
	136-0220-00	B112460		8	. SOCKET,PLUG-IN:3 PIN,SQUARE					71785	133-23-11-034	
	136-0292-02	B112460		1	. SOCKET,PLUG-IN:14 CONTACT,LOW-CLEARANCE					01295	C931402	

Replaceable Mechanical Parts--7704A

FIGURE 2 A7704 FRONT (CONT)

Fig. & Index No.	Tektronix Part No.	Serial/Model No. Eff Dscont	Qty	1	2	3	4	5	Name & Description	Mfr Code	Mfr Part Number
2-43	-----	-----	3	.	RES.,VAR:(SEE R1063,R1065,R1067 EPL)						
-44	210-0223-00	XB010210	2	.	TERMINAL,LUG:0.25 INCH DIA,SE (ATTACHING PARTS)					86928	A313-136
-45	210-0583-00	XB010210	1	.	NUT,PLAIN,HEX.:0.25-32 X 0.312 INCH,BRS - - - * - - -					73743	2X20224-402
-46	211-0504-00		3	SCREW,MACHINE:6-32 X 0.25 INCH,PNH STL						83385	OBD
-47	385-0099-00		1	INS,STANDOFF:0.25 OD X 0.625 INCH LONG (ATTACHING PARTS)						80009	385-0099-00
-48	211-0504-00		1	SCREW,MACHINE:6-32 X 0.25 INCH,PNH STL - - - * - - -						83385	OBD
-49	337-1558-00		1	SHLD,ELECTRICAL: (ATTACHING PARTS)						80009	337-1558-00
-50	211-0507-00		3	SCREW,MACHINE:6-32 X 0.312 INCH,PNH STL						83385	OBD
-51	210-0457-00		3	NUT,PLAIN,EXT W:6-32 X 0.312 INCH,STL - - - * - - -						83385	OBD
-52	351-0181-03		4	GUIDE,SLIDE:LWR,PLUG-IN UNIT (ATTACHING PARTS FOR EACH)						80009	351-0181-03
-53	213-0054-00		1	SCR,TPG,THD FOR:6-32 X 0.312 INCH,PNH STL - - - * - - -						83385	OBD
-54	376-0127-00		1	COUPLER,SHAFT:PLASTIC						80009	376-0127-00
-55	260-1222-00		1	SWITCH,PUSH-PUL:10A,250VAC						91929	2DM301
-56	210-0202-00		1	TERMINAL,LUG:SE #6 (ATTACHING PARTS)						78189	2104-06-00-2520N
-57	211-0504-00		1	SCREW,MACHINE:6-32 X 0.25 INCH,PNH STL						83385	OBD
-58	210-0457-00		1	NUT,PLAIN,EXT W:6-32 X 0.312 INCH,STL - - - * - - -						83385	OBD
-59	377-0119-00		4	PAD,CUSHIONING::PLASTIC						80009	377-0119-00
-60	348-0074-01		2	SPT PIVOT,FLIP:RIGHT FRONT AND LEFT REAR (ATTACHING PARTS FOR EACH)						80009	348-0074-01
-61	211-0532-00		2	SCREW,MACHINE:6-32 X 0.75 INCH,FILH STL						83385	OBD
-62	210-0457-00		2	NUT,PLAIN,EXT W:6-32 X 0.312 INCH,STL - - - * - - -						83385	OBD
-63	348-0073-01		2	SPT PIVOT,FLIP:LEFT FRONT AND RIGHT REAR (ATTACHING PARTS FOR EACH)						80009	348-0073-01
-64	211-0532-00		2	SCREW,MACHINE:6-32 X 0.75 INCH,FILH STL						83385	OBD
-65	210-0457-00		2	NUT,PLAIN,EXT W:6-32 X 0.312 INCH,STL - - - * - - -						83385	OBD
-66	343-0256-00		2	RTRNR BLK,SCOPE: (ATTACHING PARTS FOR EACH)						80009	343-0256-00
-67	213-0192-00		2	SCR,TPG,THD FOR:6-32 X 0.50 INCH,PNH STL						87308	OBD
-68	210-0457-00		2	NUT,PLAIN,EXT W:6-32 X 0.312 INCH,STL - - - * - - -						83385	OBD
-69	348-0193-00		1	FLIP-STAND,CAB.:						80009	348-0193-00
	672-0571-00	XB160000	1	CKT BOARD ASSY:PROTECTION AND MAIN INTFC ASSY							
-70	-----	XB160000	1	. CKT BOARD ASSY:PROTECTION(SEE A51 EPL)							
-71	-----		1	. CKT BOARD ASSY:MAIN INTERFACE(SEE A20 EPL)							
-72	388-1382-01		1	. . . CIRCUIT BOARD--VERTICAL INTERCONNECT						80009	388-1382-01
-73	131-0787-00		8	. . . CONTACT,ELEC:0.64 INCH LONG						22526	47359
-74	131-0590-00		27	. . . CONTACT,ELEC:0.71 INCH LONG						22526	47351
	131-0592-00		31	. . . CONTACT,ELEC:0.885 INCH LONG						22526	47353
	131-0589-00		10	. . . CONTACT,ELEC:0.46 INCH LONG						22526	47350
	131-0608-00		54	. . . CONTACT,ELEC:0.365 L X 0.25 PH BRZ GOLD PL						22526	47357
-75	131-0827-00		7	. . . CONTACT,ELEC:0.55 INCH LONG						22526	47349
-76	131-0595-00		6	. . . CONTACT,ELEC:1.37 INCH LONG						22526	47355
-77	131-1003-00		11	. . . CONNECTOR BODY,:CKT CD MT,3 PRONG						80009	131-1003-00
-78	211-0008-00		2	. . . SCREW,MACHINE:4-40 X 0.25 INCH,PNH STL						83385	OBD
	136-0252-04		55	. . . SOCKET,PIN TERM:0.188 INCH LONG						22526	75060
-79	131-0805-00		3	. . . LINK,TERM.CONNE:J-SHAPE,0.90X0.82 X 0.312" (ATTACHING PARTS FOR EACH)						80009	131-0805-00
-80	220-0561-00		1	. . . NUT,PLAIN,HEX.:10-32 X 0.25 INCH,BRS - - - * - - -						80009	220-0561-00
-81	351-0213-00		2	. . . GUIDE-POST,LOCK:0.285 INCH LONG						80009	351-0213-00
-82	351-0188-00		2	. . . GUIDE-POST,LOCK:0.65 INCH LONG						80009	351-0188-00

FIGURE 2 A7704 FRONT (CONT)

Fig. & Index No.	Tektronix Part No.	Serial/Model No. Eff	Dscont	Qty	1	2	3	4	5	Name & Description	Mfr Code	Mfr Part Number
2-83	351-0186-00			3	GUIDE-POST,LOCK:0.84 INCH LONG	80009	351-0186-00
-84	351-0185-00			1	GUIDE-POST,LOCK:0.65 INCH LONG	80009	351-0185-00
-85	351-0227-00			3	GUIDE-POST,LOCK:0.84 INCH LONG	80009	351-0227-00
-86	380-0262-00			2	HOUSING,CONN: (ATTACHING PARTS FOR EACH)	80009	380-0262-00
-87	211-0097-00			2	SCREW,MACHINE:4-40 X 0.312 INCH,PNH STL	83385	OBD
-88	210-0586-00			2	NUT,PLAIN,EXT W:4-40 X 0.25 INCH,STL - - - * - - -	78189	OBD
-89	131-1101-00			4	CONTACT,ELEC:MALE	00779	51563-1
-90	131-1102-00			3	CONTACT,ELEC:FEMALE	00779	51565-1
	131-0767-00	B010100	B059999	2	CONNECTOR,RCPT,:76 CONTACT	80009	131-0767-00
	131-0767-07	B060000		2	CONNECTOR,RCPT,:PLUG-IN CKT BD,70 CONTACT	80009	131-0767-07
-91	200-0950-00			2	COVER,ELEC CONN:PLASTIC	80009	200-0950-00
-92	204-0365-02			1	BODY,CONNECTOR:PLUG-IN CIRCUIT CARD	80009	204-0365-02
-93	131-0726-00	B010100	B059999	38	CONTACT,ELEC:STRAIGHT	80009	131-0726-00
	131-0726-00	B060000		35	CONTACT,ELEC:STRAIGHT	80009	131-0726-00
-94	131-0727-00	B010100	B059999	38	CONTACT,ELEC:OFFSET	80009	131-0727-00
	131-0727-00	B060000		35	CONTACT,ELEC:OFFSET (ATTACHING PARTS FOR EACH)	80009	131-0727-00
-95	213-0034-00			3	SCR,TPG,THD CTG:4-40 X 0.188 INCH,PNH STL	83385	OBD
-96	213-0232-00			2	SCR,TPG,THD FOR:2-32 X 0.312 INCH,PNH STL - - - * - - -	83385	OBD
	131-0767-02	B010100	B059999	2	CONNECTOR,RCPT,:76 CONTACT	80009	131-0767-02
	131-0767-08	B060000		2	CONNECTOR,RCPT,:PLUG-IN CKT BD,70 CONTACT	80009	131-0767-08
-97	200-0950-00			2	COVER,ELEC CONN:PLASTIC	80009	200-0950-00
-98	204-0365-00	B010100	B204403	1	BODY,CONNECTOR:PLUG-IN CIRCUIT CARD	80009	204-0365-00
	204-0365-02	B204402		1	BODY,CONNECTOR:PLUG-IN CIRCUIT CARD	80009	204-0365-02
-99	131-0726-00	B010100	B059999	36	CONTACT,ELEC:STRAIGHT	80009	131-0726-00
	131-0726-00	B060000		33	CONTACT,ELEC:STRAIGHT	80009	131-0726-00
-100	131-0727-00	B010100	B059999	36	CONTACT,ELEC:OFFSET	80009	131-0727-00
	131-0727-00	B060000		33	CONTACT,ELEC:OFFSET	80009	131-0727-00
-101	131-0899-00			4	CONTACT,ELEC:0.048 X 0.006 INCH THK (ATTACHING PARTS FOR EACH)	80009	131-0899-00
-102	213-0034-00	B010100	B204403	3	SCR,TPG,THD CTG:4-40 X 0.188 INCH,PNH STL	83385	OBD
	213-0263-00	B204402		3	SCR,TPG,THG FOR:4-24 X 0.375 INCH,PNH STL	83385	OBD
-103	213-0232-00			2	SCR,TPG,THD FOR:2-32 X 0.312 INCH,PNH STL - - - * - - -	83385	OBD
-104	131-0930-00			6	CONTACT,ELEC:PLUG-IN GROUND (ATTACHING PARTS FOR EACH)	80009	131-0930-00
-105	211-0008-00			1	SCREW,MACHINE:4-40 X 0.25 INCH,PNH STL	83385	OBD
-106	210-0586-00			1	NUT,PLAIN,EXT W:4-40 X 0.25 INCH,STL - - - * - - -	78189	OBD
-107	131-0800-00			2	CONTACT,ELEC:PLUG-IN GROUND (ATTACHING PARTS FOR EACH)	80009	131-0800-00
-108	213-0138-00			2	SCR,TPG,THD FOR:4-40 X 0.188 INCH,PNH STL - - - * - - -	83385	OBD
-109	426-0813-00			1	FRAME,PLUG-IN H:	80009	426-0813-00
-110	352-0162-00			1	CONN BODY,PL,EL:4 WIRE BLACK	80009	352-0162-00
-111	131-0707-00			2	CONNECTOR,TERM.:0.48" L,22-26AWG WIRE	22526	75691-005
	131-0708-00			2	CONTACT,ELEC:0.48"L,28-32 AWG WIRE	22526	47437
-112	210-0775-00			3	EYELET,METALLIC:0.126 OD X 0.23 INCH L,BRS	80009	210-0775-00
-113	210-0774-00			3	EYELET,METALLIC:0.152 OD X 0.245 INCH L,BRS (ATTACHING PARTS)	80009	210-0774-00
-114	211-0504-00			4	SCREW,MACHINE:6-32 X 0.25 INCH,PNH STL	83385	OBD
-115	210-0457-00			4	NUT,PLAIN,EXT W:6-32 X 0.312 INCH,STL - - - * - - -	83385	OBD
-116	-----			1	CKT BOARD ASSY:HORIZONTAL INTERFACE(SEE A23 EPL)		
-117	131-0787-00			4	CONTACT,ELEC:0.64 INCH LONG	22526	47359
-118	136-0252-04			22	SOCKET,PIN TERM:0.188 INCH LONG	22526	75060
-119	136-0263-03	B010100	B153439	11	SOCKET,PIN TERM:FOR 0.025 INCH SQUARE PIN	00779	86250-2
	136-0263-04	B153440		11	SOCKET,PIN TERM:FOR 0.025 INCH SQUARE PIN	22526	48059
-120	361-0238-00			2	SPACER,SLEEVE:0.25 OD X 0.34 INCH LONG	80009	361-0238-00
-121	211-0155-00			2	SCREW,EXT,RLV B:4-40 X 0.375 INCH,SST	80009	211-0155-00
-122	-----			1	CKT BOARD ASSY:TRIGGER SELECTOR(SEE A24 EPL)		
-123	131-0787-00			4	CONTACT,ELEC:0.64 INCH LONG	22526	47359

Replaceable Mechanical Parts—7704A

FIGURE 2 A7704 FRONT (CONT)

Fig. & Index No.	Tektronix Part No.	Serial/Model No. Eff	Model No. Dscont	Qty	1	2	3	4	5	Name & Description	Mfr Code	Mfr Part Number
2-124	136-0252-04			50	.					SOCKET,PIN TERM:0.188 INCH LONG	22526	75060
-125	136-0263-03	B010100	B153439	16	.					SOCKET,PIN TERM:FOR 0.025 INCH SQUARE PIN	00779	86250-2
	136-0263-04	B153440		16	.					SOCKET,PIN TERM:FOR 0.025 INCH SQUARE PIN	22526	75377-001
-126	361-0238-00			2	.					SPACER,SLEEVE:0.25 OD X 0.34 INCH LONG	80009	361-0238-00
-127	211-0155-00			2	.					SCREW,EXT,RLV B:4-40 X 0.375 INCH,SST	80009	211-0155-00
-128	-----			1						CKT BOARD ASSY:VERTICAL INTERFACE(SEE A22 EPL)		
-129	131-1003-00			2	.					CONNECTOR BODY,:CKT CD MT,3 PRONG	80009	131-1003-00
-130	136-0252-04			55	.					SOCKET,PIN TERM:0.188 INCH LONG	22526	75060
-131	136-0263-03	B010100	B153439	18	.					SOCKET,PIN TERM:FOR 0.025 INCH SQUARE PIN	00779	86250-2
	136-0263-04	B153440		18	.					SOCKET,PIN TERM:FOR 0.025 INCH SQUARE PIN	22526	75377-001
-132	361-0238-00			2	.					SPACER,SLEEVE:0.25 OD X 0.34 INCH LONG	80009	361-0238-00
-133	211-0155-00			2	.					SCREW,EXT,RLV B:4-40 X 0.375 INCH,SST	80009	211-0155-00
-134	-----			1						CKT BOARD ASSY:LOGIC(SEE A25 EPL)		
-135	131-1003-00			1	.					CONNECTOR BODY,:CKT CD MT,3 PRONG	80009	131-1003-00
-136	136-0252-04	B010100	B112459	115	.					SOCKET,PIN TERM:0.188 INCH LONG	22526	75060
	136-0220-00	B112460		9	.					SOCKET,PLUG-IN:3 PIN,SQUARE	71785	133-23-11-034
	136-0241-00	B112460		4	.					SOCKET,PLUG-IN:10 CONTACT,ROUND	71785	133-99-12-064
	136-0260-02	B112460		3	.					SOCKET,PLUG-IN:16 CONTACT,LOW CLEARANCE	01295	C931602
-137	136-0263-03	B010100	B153439	33	.					SOCKET,PIN TERM:FOR 0.025 INCH SQUARE PIN	00779	86250-2
	136-0263-04	B153440		33	.					SOCKET,PIN TERM:FOR 0.025 INCH SQUARE PIN	22526	75377-001
-138	260-0723-00			1	.					SWITCH,SLIDE:DPDT,0.5A,125VAC	79727	GF126-0028
-139	361-0238-00			3	.					SPACER,SLEEVE:0.25 OD X 0.34 INCH LONG	80009	361-0238-00
-140	211-0155-00			3	.					SCREW,EXT,RLV B:4-40 X 0.375 INCH,SST	80009	211-0155-00
	131-0566-00	XB110000		1	.					LINK,TERM.CONNE:0.086 DIA X 2.375 INCH L	55210	L-2007-1
-141	426-0814-00			2						FRAME SECT,CAB.:BOTTOM	80009	426-0814-00
-142	426-0818-00			2						FRAME SECT,CAB.:TOP	80009	426-0818-00
-143	426-0849-00			2						FRAME SECT,CAB.:COUPLING	80009	426-0849-00

FIGURE 2 A7704 FRONT (CONT)

Fig. & Index No.	Tektronix Part No.	Serial/Model No. Eff	Dscont	Qty	1	2	3	4	5	Name & Description	Mfr Code	Mfr Part Number
3-1	-----			1						CKT BOARD ASSY:READOUT(SEE A34 EPL)		
-2	131-0608-00			24						. CONTACT,ELEC:0.365L X 0.25 PH BRZ GOLD PL	22526	47357
-3	131-0771-00			2						. CONNECTOR,RCPT,:4 CONT,QUICK DISCONNECT (ATTACHING PARTS FOR EACH)	0000A	ROA-304NYL
-4	220-0551-00			1						. NUT,PLAIN,HEX.:9 MM X 0.437 INCH - - - * - - -	73743	OBD
-5	131-1003-00			5						. CONNECTOR BODY,:CKT CD MT,3 PRONG	80009	131-1003-00
-6	136-0252-04	B010100	B112459	273						. SOCKET,PIN TERM:0.188 INCH LONG	22526	75060
	136-0235-00	B112460		1						. SOCKET,PLUG-IN:6 CONTACT,ROUND	71785	133-96-12-062
	136-0220-00	B112460		11						. SOCKET,PLUG-IN:3 PIN,SQUARE	71785	133-23-11-034
	136-0260-00	B112460		12						. SOCKET,PLUG-IN:16 CONTACT,RECT SHAPE	71785	133-51-92-008
	136-0269-02	B112460		3						. SOCKET,PLUG-IN:14 CONTACT,LOW CLEARANCE	01295	C951401
-7	214-0579-00			2						. TERM.,TEST PT:0.40 INCH LONG	80009	214-0579-00
-8	211-0097-00			4						. SCREW,MACHINE:4-40 X 0.312 INCH,PNH STL	83385	OBD
-9	441-1065-00			1						. CHAS,PL-IN UNIT:READOUT	80009	441-1065-00
-10	386-2153-00			1						. PANEL,REAR:READOUT	80009	386-2153-00
-11	352-0162-00			2						. CONN BODY,PL,EL:4 WIRE BLACK	80009	352-0162-00
-12	352-0168-00			4						. CONN BODY,PL,EL:10 WIRE BLACK	80009	352-0168-00
-13	131-0707-00			48						. CONNECTOR,TERM.:0.48" L,22-26AWG WIRE	22526	75691-005
-14	175-0827-00			IN						. WIRE,ELECTRICAL:4 WIRE RIBBON	08261	S8-0426-710610C
-15	175-0833-00			IN						. WIRE,ELECTRICAL:10 WIRE RIBBON	08261	OBD
-16	210-0775-00			5						. EYELET,METALLIC:0.126 OD X 0.23 INCH L,BRS	80009	210-0775-00
-17	210-0774-00			5						. EYELET,METALLIC:0.152 OD X 0.245 INCH L,BRS	80009	210-0774-00
	198-2816-00			1						. WIRE SET,ELEC: (ATTACHING PARTS)	80009	198-2816-00
-18	211-0507-00			2						. SCREW,MACHINE:6-32 X 0.312 INCH,PNH STL - - - * - - -	83385	OBD
-19	-----			1						CKT BOARD ASSY:SIGNAL OUTPUT(SEE A33 EPL)		
-20	131-0955-00			5						. CONNECTOR,RCPT,:BNC,FEMALE,W/HARDWARE	05091	31-279
-21	131-1003-00			8						. CONNECTOR BODY,:CKT CD MT,3 PRONG	80009	131-1003-00
-22	131-0608-00			6						. CONTACT,ELEC:0.365L X 0.25 PH BRZ GOLD PL	22526	47357
-23	136-0252-04	B010100	B112459	36						. SOCKET,PIN TERM:0.188 INCH LONG	22526	75060
	136-0220-00	B112460		12						. SOCKET,PLUG-IN:3 PIN,SQUARE	71785	133-23-11-034
-24	260-0723-00			2						. SWITCH,SLIDE:DPDT,0.5A,125VAC	79727	GF126-0028
-25	260-0984-00			1						. SWITCH,SLIDE:DP 3 POSN,0.5A,125VAC-DC	79727	G-228SPC/2140
-26	441-1064-00			1						. CHAS,PL-IN UNIT: SIGNALS OUT	80009	441-1064-00
-27	211-0097-00			3						. SCREW,MACHINE:4-40 X 0.312 INCH,PNH STL	83385	OBD
-28	210-0201-00			1						. TERMINAL,LUG:SE #4	78189	2104-04-00-2520N
-29	386-2152-00			1						. PANEL,REAR: SIGNALS OUT (ATTACHING PARTS)	80009	386-2152-00
-30	211-0507-00			2						. SCREW,MACHINE:6-32 X 0.312 INCH,PNH STL - - - * - - -	83385	OBD
-31	386-2133-00			1						. PANEL,REAR: (ATTACHING PARTS)	80009	386-2133-00
-32	211-0507-00			2						. SCREW,MACHINE:6-32 X 0.312 INCH,PNH STL - - - * - - -	83385	OBD
-33	426-0807-01			1						. FRAME PNL,CAB.:REAR (ATTACHING PARTS)	80009	426-0807-01
	213-0270-00			4						. SCR,TPG,THD FOR:10-32 X 0.75 INCH FILH STL - - - * - - -	83385	OBD
	620-0230-00			1						. POWER SUPPLY:	80009	620-0230-00
-34	-----			1						. CKT BD ASSY:RECTIFIER AND FILTER(SEE A31 EPL)		
-35	131-0608-00	B010100	B194124	11						. . CONTACT,ELEC:0.365L X 0.25 PH BRZ GOLD PL	22526	47357
	131-0589-00	B194125		11						. . CONTACT,ELEC:0.46 INCH LONG	22526	47350
-36	131-1003-00			2						. . CONNECTOR BODY,:CKT CD MT,3 PRONG	80009	131-1003-00
-37	136-0252-04	B010100	B112459	22						. . SOCKET,PIN TERM:0.188 INCH LONG	22526	75060
	136-0220-00	B112460		12						. . SOCKET,PLUG-IN:3 PIN,SQUARE	71785	133-23-11-034
	136-0260-02	B112460		1						. . SOCKET,PLUG-IN:16 CONTACT,LOW CLEARANCE	82647	C951601
-38	136-0263-03	B010100	B153439	7						. . SOCKET,PIN TERM:FOR 0.025 INCH SQUARE PIN	00779	86250-2
	136-0263-04	B153440		7						. . SOCKET,PIN TERM:FOR 0.025 INCH SQUARE PIN (ATTACHING PARTS)	22526	48059
-39	210-0586-00			4						. NUT,PLAIN,EXT W:4-40 X 0.25 INCH,STL	78189	OBD
-40	211-0008-00			4						. SCREW,MACHINE:4-40 X 0.25 INCH,PNH STL - - - * - - -	83385	OBD

Replaceable Mechanical Parts—7704A

FIGURE 2 A7704 FRONT (CONT)

Fig. & Index No.	Tektronix Part No.	Serial/Model No. Eff	Dscont	Qty	1	2	3	4	5	Name & Description	Mfr Code	Mfr Part Number
3-41	337-1490-00			1	.					SHLD,ELECTRICAL:CIRCUIT CARD (ATTACHING PARTS)	80009	337-1490-00
-42	211-0040-00			2	.					SCREW,MACHINE:4-40 X 0.25",BDGH PLSTC - - - * - - -	26365	OBD
-43	-----			1	.					CKT BOARD ASSY:POWER SUPPLY INVERTER (SEE A30 EPL)		
-44	129-0323-00			2	.	.				POST,ELEC-MECH:HEX,0.25 X 1 INCH LONG (ATTACHING PARTS)	80009	129-0323-00
-45	211-0097-00			1	.	.				SCREW,MACHINE:4-40 X 0.312 INCH,PNH STL - - - * - - -	83385	OBD
-46	131-0591-00			7	.	.				CONTACT,ELEC:0.835 INCH LONG	22526	47352
-47	136-0254-01			4	.	.				SOCKET,PIN TERM:0.145 INCH LONG	00779	1-331892-8
-48	344-0230-00			1	.	.				CLIP,SPG,TNSN:	80009	344-0230-00
-49	212-0518-00			2	.	.				CAPACITOR:(SEE C3016,C3017 EPL) (ATTACHING PARTS FOR EACH)		
-50	214-0579-00			3	.	.				SCREW,MACHINE:10-32 X 0.312 INCH,PNH STL - - - * - - -	83385	OBD
-51	348-0023-00			6	.	.				TERM.,TEST PT:0.40 INCH LONG	80009	214-0579-00
-52	211-0012-00			2	.	.				PLUG,HOLE:	80009	348-0023-00
-53	210-0586-00			2	.	.				TRANSISTOR:(SEE Q3034,Q3037 EPL) (ATTACHING PARTS FOR EACH)		
-54	386-0978-00			1	.	.				SCREW,MACHINE:4-40 X 0.375 INCH,PNH STL	83385	OBD
-55	214-1624-00			1	.	.				NUT,PLAIN,EXT W:4-40 X 0.25 INCH,STL	78189	OBD
-56	342-0103-00			1	.	.				INSULATOR,PLATE:0.002 INCH MICA,FOR TO-3 - - - * - - -	80009	386-0978-00
-57	211-0512-00			1	.	.				HEATSINK-SHIELD	80009	214-1624-00
-58	210-0457-00			1	.	.				INSULATOR,BLOCK: (ATTACHING PARTS)	80009	342-0103-00
-59	213-0183-00			2	.	.				SCREW,MACHINE:6-32 X 0.50" 100 DEG,FLH STL	83385	OBD
-60	214-1625-00			1	.	.				NUT,PLAIN,EXT W:6-32 X 0.312 INCH,STL	83385	OBD
-61	337-1491-00			1	.	.				SCR,TPG,THD FOR:6-32 X 0.25 INCH,PNH STL - - - * - - -	83385	OBD
-62	344-0118-00			2	.	.				SPRING,FLAT:2.0 INCH LONG,BOWED	80009	214-1625-00
-63	210-0623-00			4	.	.				SHLD,ELECTRICAL:CIRCUIT CARD	80009	337-1491-00
-64	211-0008-00			2	.	.				CLIP,SPG TENS:CAPACITOR MTG	80033	E50008-044
-65	346-0032-00			4	.	.				RIVET,TUBULAR: (ATTACHING PARTS)	12014	R-3682
-66	348-0005-00			3	.	.				SCREW,MACHINE:4-40 X 0.25 INCH,PNH STL - - - * - - -	83385	OBD
-67	211-0008-00			1	.	.				STRAP,RETAINING:	98159	2829-75-4
-68	210-0586-00			1	.	.				GROMMET,RUBBER:0.50 INCH DIA (ATTACHING PARTS)	70485	230
-69	211-0504-00			3	.	.				SCREW,MACHINE:4-40 X 0.25 INCH,PNH STL	83385	OBD
-70	211-0504-00			1	.	.				NUT,PLAIN,EXT W:4-40 X 0.25 INCH,STL	78189	OBD
-71	407-1014-00			1	.	.				SCREW,MACHINE:6-32 X 0.25 INCH,PNH STL	83385	OBD
-72	129-0318-00			1	.	.				BRACKET,CKT: - - - * - - -	80009	407-1014-00
-73	129-0318-00			1	.	.				INSULATOR,STDF:0.312 OD X 2.17 INCH LONG (ATTACHING PARTS)	80009	129-0318-00
-74	211-0504-00			1	.	.				SCREW,MACHINE:6-32 X 0.25 INCH,PNH STL - - - * - - -	83385	OBD
-75	220-0623-00			1	.	.				NUT,BLOCK: (ATTACHING PARTS)	80009	220-0623-00
-76	211-0504-00			1	.	.				SCREW,MACHINE:6-32 X 0.25 INCH,PNH STL - - - * - - -	83385	OBD
-77	-----			1	.	.				CKT BOARD ASSY:REGULATOR(SEE A32 EPL)		
-78	131-0608-00			15	.	.				CONTACT,ELEC:0.365 L X 0.25 PH BRZ GOLD PL	22526	47357
-79	136-0252-04	B010100	B112459	90	.	.				SOCKET,PIN TERM:0.188 INCH LONG	22526	75060
-80	136-0235-00	B112460		8	.	.				SOCKET,PLUG-IN:6 CONTACT,ROUND	71785	133-96-12-062
-81	136-0220-00	B112460		9	.	.				SOCKET,PLUG-IN:3 PIN,SQUARE	71785	133-23-11-034
-82	136-0183-00	B112460		5	.	.				SOCKET,PLUG-IN:3 PIN,ROUND (ATTACHING PARTS)	80009	136-0183-00
-83	211-0008-00			4	.	.				SCREW,MACHINE:4-40 X 0.25 INCH,PNH STL - - - * - - -	83385	OBD

FIGURE 2 A7704 FRONT (CONT)

Fig. & Index No.	Tektronix Part No.	Serial/Model No. Eff	Dscont	Qty	1	2	3	4	5	Name & Description	Mfr Code	Mfr Part Number
3-77	337-1545-00			1	.					SHLD,ELECTRICAL:POWER SUPPLY (ATTACHING PARTS)	80009	337-1545-00
-78	211-0008-00			2	.					SCREW,MACHINE:4-40 X 0.25 INCH,PNH STL	83385	OBD
-79	-----			1	.					TRANSFORMER (SEE T4201 EPL) (ATTACHING PARTS)		
-80	211-0008-00			4	.					SCREW,MACHINE:4-40 X 0.25 INCH,PNH STL	83385	OBD
-81	-----			5	.					TRANSISTOR (ATTACHING PARTS FOR EACH)		
-82	211-0578-00			1	.					SCREW,MACHINE:6-32 X 0.438 INCH,PNH STL	83385	OBD
-83	210-0409-00			1	.					NUT,PLAIN,HEX.:8-32 X 0.312 INCH,BRS	73743	3046-402
-84	210-0071-00			1	.					WASHER,SPR TMSN:0.146 ID X 0.323" OD,STL	78189	4706-05-01-0531
-85	342-0136-00			1	.					INSULATOR,WSHR:0.812 OD X 0.0025 INCH THK	04713	OBD
-86	210-0201-00	B010100	B091620	3	.					TERMINAL,LUG:SE #4	78189	2104-04-00-2520N
	210-0201-00	B091621		1	.					TERMINAL,LUG:SE #4 (ATTACHING PARTS FOR EACH)	78189	2104-04-00-2520N
-87	211-0008-00			1	.					SCREW,MACHINE:4-40 X 0.25 INCH,PNH STL	83385	OBD
-88	210-0586-00			1	.					NUT,PLAIN,EXT W:4-40 X 0.25 INCH,STL	78189	OBD
-89	161-0033-06	B010100	B091620	1	.					CABLE ASSY,PWR,:	80009	161-0033-06
	161-0066-00	B091621		1	.					CABLE ASSY,PWR,:3 WIRE,98 INCH LONG (ATTACHING PARTS)	80009	161-0066-00
-90	210-0413-00			1	.					NUT,PLAIN,HEX.:0.375-32 X 0.50 INCH,STL	73743	3145-402
-91	210-0012-00			1	.					WASHER,LOCK:INTL,0.375 ID X 0.50" OD STL	78189	1220-02-00-0541C
-92	-----	B010100	B091620	1	.					COIL:(SEE L5020/L5022 EPL) (ATTACHING PARTS)		
-93	213-0138-00	B010100	B091620	1	.					SCR,TPG,THD FOR:4-40 X 0.188 INCH,PNH STL	83385	OBD
-94	348-0055-00	B010100	B091620	1	.					GROMMET,PLASTIC:0.25 INCH DIA	80009	348-0055-00
-95	337-1666-00	B010100	B091620	1	.					SHLD,ELECTRICAL: (SEE FL5020 EPL) (ATTACHING PARTS)	80009	337-1666-00
	211-0012-00	B091621		2	.					SCREW,MACHINE:4-40 X 0.375 INCH,PNH STL	83385	OBD
-96	260-0449-00			1	.					SWITCH,SLIDE:SPDT,0.5A,125VA-DC (ATTACHING PARTS)	82389	11A-1030A
-97	211-0101-00			2	.					SCREW,MACHINE:4-40 X 0.25" 100 DEG,FLH STL	83385	OBD
-98	210-0586-00			2	.					NUT,PLAIN,EXT W:4-40 X 0.25 INCH,STL	78189	OBD
-99	386-2155-00	B010100	B091620	1	.					PANEL,HEATSINK:	80009	386-2155-00
	386-2155-01	B091621		1	.					PANEL,HEATSINK:	80009	386-2155-01
-100	337-1546-00			1	.					SHLD ELECTRICAL:SHIELD,POWER SUPPLY (ATTACHING PARTS)	80009	337-1546-00
-101	211-0007-00			4	.					SCREW,MACHINE:4-40 X 0.188 INCH,PNH STL	83385	OBD
-102	200-0763-04			1	.					COV,LINE VOLTAG:	80009	200-0763-04
-103	352-0102-00			2	.					FUSEHOLDER:0.262"ID TUBE FOR CRTG FUSE	80009	352-0102-00
-104	213-0088-00			4	.					SCR,TPG,THD CTG:4-24 X 0.25 INCH,PNH STL	83385	OBD
-105	204-0278-01			1	.					BODY ASSY,LINE: (ATTACHING PARTS)	80009	204-0278-01
-106	210-0408-00			2	.					NUT,PLAIN,HEX.:6-32 X 0.312 INCH,BRS	73743	3040-402
-107	342-0104-00			1	.					INSULATOR,PLATE:2 X 4.40 INCHES (ATTACHING PARTS FOR POWER SUPPLY)	80009	342-0104-00
-108	211-0507-00			4	.					SCREW,MACHINE:6-32 X 0.312 INCH,PNH STL	83385	OBD

FIGURE 4 CABINET AND ACCESSORIES

Fig. & Index No.	Tektronix Part No.	Serial/Model No. Eff	Dscont	Qty	1	2	3	4	5	Name & Description	Mfr Code	Mfr Part Number
4-1	390-0251-00			2						CAB SIDE,SCOPE:	80009	390-0251-00
	214-0816-00			2						. LATCH ASSEMBLY:	80009	214-0816-00
-2	214-0603-01			1						. . PIN,SECURING:0.27 INCH LONG	80009	214-0603-01
-3	214-0604-00			1						. . WASH.,SPG TNSN:0.26 ID X 0.47 INCH OD	80009	214-0604-00
-4	386-0227-00			1						. . PL,LATCH INDEX:	80009	386-0227-00
-5	386-1151-00			1						. . PLATE,LATCH LKG:	80009	386-1151-00
-6	200-0728-00			2						COV,HANDLE END:	80009	200-0728-00
-7	367-0108-00			1						HANDLE,SCOPE:	80009	367-0108-00
										(ATTACHING PARTS)		
-8	212-0597-00			4						SCREW,MACHINE:10-32 X 0.50 INCH,STL	93907	OBD
-9	386-1624-00			2						PL,RET.,HANDLE:	80009	386-1624-00
-10	386-1283-00			2						PLATE,HDL MTG:PLASTIC	80009	386-1283-00
										- - - * - - -		
-11	426-0819-00			1						FRAME SECT,CAB.:TOP CENTER	80009	426-0819-00
										(ATTACHING PARTS)		
	213-0270-00			2						SCR,TPG,THD FOR:10-32 X 0.75 INCH FILH STL	83385	OBD
										- - - * - - -		
-12	390-0255-00			2						CAB SIDE,SCOPE:	80009	390-0255-00
	214-0816-00			2						. LATCH ASSEMBLY:	80009	214-0816-00
-13	214-0603-01			1						. . PIN,SECURING:0.27 INCH LONG	80009	214-0603-01
-14	214-0604-00			1						. . WASH.,SPG TNSN:0.26 ID X 0.47 INCH OD	80009	214-0604-00
-15	386-0227-00			1						. . PL,LATCH INDEX:	80009	386-0227-00
-16	386-1151-00			1						. . PLATE,LATCH LKG:	80009	386-1151-00
-17	390-0256-00			1						CAB BOT,SCOPE:	80009	390-0256-00
	214-0816-00			6						. LATCH ASSEMBLY:	80009	214-0816-00
-18	214-0603-01			1						. . PIN,SECURING:0.27 INCH LONG	80009	214-0603-01
-19	214-0604-00			1						. . WASH.,SPG TNSN:0.26 ID X 0.47 INCH OD	80009	214-0604-00
-20	386-0227-00			1						. . PL,LATCH INDEX:	80009	386-0227-00
-21	386-1151-00			1						. . PLATE,LATCH LKG:	80009	386-1151-00

ACCESSORIES

-22	175-1178-00			1						CABLE,SP ELECT:	80009	175-1178-00
	070-1260-00			1						MANUAL:INSTRUCTION (NOT SHOWN)	80009	070-1260-00
	016-0155-00			1						PLUG-IN PANEL:BLANK(OPTIONAL ACCESSORY FOR OPTION 3)	80009	016-0155-00

MANUAL CHANGE INFORMATION

At Tektronix, we continually strive to keep up with latest electronic developments by adding circuit and component improvements to our instruments as soon as they are developed and tested.

Sometimes, due to printing and shipping requirements, we can't get these changes immediately into printed manuals. Hence, your manual may contain new change information on following pages.

A single change may affect several sections. Since the change information sheets are carried in the manual until all changes are permanently entered, some duplication may occur. If no such change pages appear following this page, your manual is correct as printed.

SERVICE NOTE

Because of the universal parts procurement problem, some electrical parts in your instrument may be different from those described in the Replaceable Electrical Parts List. The parts used will in no way alter or compromise the performance or reliability of this instrument. They are installed when necessary to ensure prompt delivery to the customer. Order replacement parts from the Replaceable Electrical Parts List.

CALIBRATION TEST EQUIPMENT REPLACEMENT

Calibration Test Equipment Chart

This chart compares TM 500 product performance to that of older Tektronix equipment. Only those characteristics where significant specification differences occur, are listed. In some cases the new instrument may not be a total functional replacement. Additional support instrumentation may be needed or a change in calibration procedure may be necessary.

Comparison of Main Characteristics

DM 501 replaces 7D13		
PG 501 replaces 107	PG 501 - Risetime less than 3.5 ns into 50 Ω .	107 - Risetime less than 3.0 ns into 50 Ω .
108	PG 501 - 5 V output pulse; 3.5 ns Risetime.	108 - 10 V output pulse; 1 ns Risetime.
111	PG 501 - Risetime less than 3.5 ns; 8 ns Pretrigger pulse delay.	111 - Risetime 0.5 ns; 30 to 250 ns Pretrigger Pulse delay.
114	PG 501 - ± 5 V output.	114 - ± 10 V output. Short proof output.
115	PG 501 - Does not have Paired, Burst, Gated, or Delayed pulse mode; ± 5 V dc Offset. Has ± 5 V output.	115 - Paired, Burst, Gated, and Delayed pulse mode; ± 10 V output. Short-proof output.
PG 502 replaces 107		
108	PG 502 - 5 V output	108 - 10 V output.
111	PG 502 - Risetime less than 1 ns; 10 ns Pretrigger pulse delay.	111 - Risetime 0.5 ns; 30 to 250 ns Pretrigger pulse delay.
114	PG 502 - ± 5 V output	114 - ± 10 V output. Short proof output.
115	PG 502 - Does not have Paired, Burst, Gated, Delayed & Undelayed pulse mode; Has ± 5 V output.	115 - Paired, Burst, Gated, Delayed & Undelayed pulse mode; ± 10 V output. Short-proof output.
2101	PG 502 - Does not have Paired or Delayed pulse. Has ± 5 V output.	2101 - Paired and Delayed pulse; 10 V output.
PG 506 replaces 106	PG 506 - Positive-going trigger output signal at least 1 V; High Amplitude output, 60 V.	106 - Positive and Negative-going trigger output signal, 50 ns and 1 V; High Amplitude output, 100 V.
067-0502-01	PG 506 - Does not have chopped feature.	0502-01 - Comparator output can be alternately chopped to a reference voltage.
SG 503 replaces 190, 190A, 190B, 191, 067-0532-01	SG 503 - Amplitude range 5 mV to 5.5 V p-p. SG 503 - Frequency range 250 kHz to 250 MHz. SG 503 - Frequency range 250 kHz to 250 MHz.	190B - Amplitude range 40 mV to 10 V p-p. 191 - Frequency range 350 kHz to 100 MHz. 0532-01 - Frequency range 65 MHz to 500 MHz.
TG 501 replaces 180, 180A	TG 501 - Marker outputs, 5 sec to 1 ns. Sinewave available at 5, 2, and 1 ns. Trigger output - slaved to marker output from 5 sec through 100 ns. One time-mark can be generated at a time.	180A - Marker outputs, 5 sec to 1 μ s. Sinewave available at 20, 10, and 2 ns. Trigger pulses 1, 10, 100 Hz; 1, 10, and 100 kHz. Multiple time-marks can be generated simultaneously.
181	TG 501 - Marker outputs, 5 sec to 1 ns. Sinewave available at 5, 2, and 1 ns.	181 - Marker outputs, 1, 10, 100, 1000, and 10,000 μ s, plus 10 ns sinewave.
184	TG 501 - Marker outputs, 5 sec to 1 ns. Sinewave available at 5, 2, and 1 ns. Trigger output - slaved to marker output from 5 sec through 100 ns. One time-mark can be generated at a time.	184 - Marker outputs, 5 sec to 2 ns. Sinewave available at 50, 20, 10, 5, and 2 ns. Separate trigger pulses of 1 and .1 sec; 10, 1, and .1 ms; 10 and 1 μ s. Marker amplifier provides positive or negative time marks of 25 V min. Marker intervals of 1 and .1 sec; 10, 1, and .1 ms; 10 and 1 μ s.
2901	TG 501 - Marker outputs, 5 sec to 1 ns. Sinewave available at 5, 2, and 1 ns. Trigger output - slaved to marker output from 5 sec through 100 ns. One time-mark can be generated at a time.	2901 - Marker outputs, 5 sec to 0.1 μ s. Sinewave available to 50, 10, and 5 ns. Separate trigger pulses, from 5 sec to 0.1 μ s. Multiple time-marks can be generated simultaneously.

NOTE: All TM 500 generator outputs are short-proof. All TM 500 plug-in instruments require TM 500-Series Power Module.

IMPORTANT NOTE

This instrument is fitted with a power cord which complies with B.S. 4743/I. E. C. 348 specifications.

The connections are as follows:-

Green/Yellow	EARTH
Brown	LIVE
Blue	NEUTRAL

Ensure that the correctly rated fuse is selected for your operating range. (Refer to OPERATING INSTRUCTIONS section at front of manual).

Unless otherwise stated your instrument is shipped ready for operation from a 240V nominal line-voltage source and fitted with the appropriate fuse.

Please amend your manual to reflect the above changes, the new power cord part number is 161-0086-02, except in the type 7704A instrument where it is 161-0086-01.

If a separate power cord retainer is required order part number 343-0170-00.

G5/773

Addendum to G5/773

In the type 7704A instrument from serial number 100180 upwards the part number of the detached power cord is 161-0100-00.

GUERNSEY TYPE - 7704A - EFFECTIVE S/N 100130 - UP

ELECTRICAL PARTS LIST AND SCHEMATIC CORRECTION

CHANGE TO -

C2231 281-0151-00 Capacitor, 1-3 pF, Cer, Var, 100 V

C2281 281-0151-00 Capacitor, 1-3 pF, Cer, Var, 100 V

NOTE : This cancels the change done on Ref. M20731/773

M2444/973

GUERNSEY TYPE 7704A - TENTATIVE SN 100250

ELECTRICAL PARTS LIST AND SCHEMATIC CHANGE

CHANGE TO -

C2445 281-0601-00 7.5 pF, Cer (nominal value) selected.

M2704/774

GUERNSEY TYPE 7704A - TENTATIVE SN 100270

ELECTRICAL PARTS LIST AND SCHEMATIC CORRECTION

ADD -

C2524 281-0629-00 CAPACITOR : 33 pF, Cer, 600 V, 5%

On Schematic  LOGIC CIRCUIT add C2524 in parallel with R2524

M2723/874

GUERNSEY TYPE 7704A - TENTATIVE S/N 100330

ELECTRICAL PARTS LIST CHANGE

CHANGE TO -

C4427 281-0161-00 CAPACITOR. VAR. 5- 15 pf

M. 2936/775

GUERNSEY TYPE 7704A - TENTATIVE S/N 100410

ELECTRICAL PARTS LIST AND SCHEMATIC CHANGE

CHANGE TO -

A34	670-1885-04	READOUT Circuit Board Assembly
R3468	321-0191-00	RES., FXD., FILM, 953 ohm, 1%, 0.125W

MOD. 3089/476
REV.

GUERNSEY TYPE 7704A - TENTATIVE S/N 100440

ELECTRICAL PARTS LIST CHANGE

CHANGE TO -

CR2209 thru) 152-0141-02 SEMICONV DEVICE : SILICON, 30 V, 150 MA
CR2240 inc.)

M3176/1076

GUERNSEY TYPE 7704A - TENTATIVE S/N 100475

ELECTRICAL PARTS LIST CHANGE

CHANGE TO -

Q3052

151-0529-00

TRANSISTOR, SILICON, SCR.

M3225/277



TEKTRONIX®
committed to
technical excellence

MANUAL CHANGE INFORMATION

PRODUCT 7704A
070-1260-00

CHANGE REFERENCE M34191
DATE 6-9-78

CHANGE:

DESCRIPTION

EFF SN B216454-up

ELECTRICAL PARTS LIST AND SCHEMATIC CHANGES

CHANGE TO:

A25 670-1884-05 CKT BOARD ASSY:LOGIC

ADD:

R2593 317-0101-00 RES.,FXD,CMPSN:100 OHM,5%,0.125W

DIAGRAM 3 LOGIC CIRCUIT - Partial

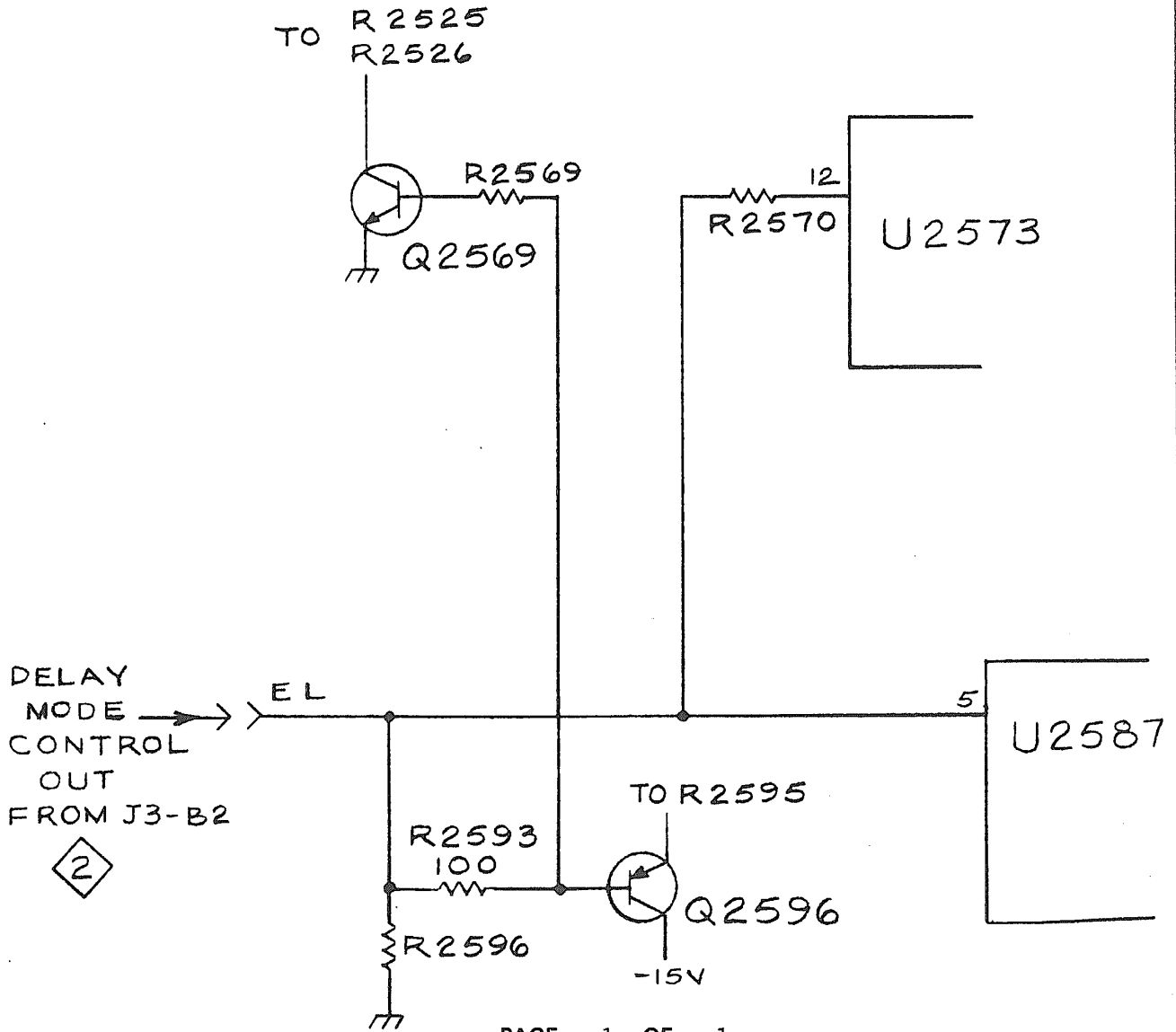



MANUAL CHANGE INFORMATION

PRODUCT 7704A
070-1260-00

CHANGE REFERENCE M34114
DATE 6-12-78

CHANGE:	DESCRIPTION
---------	-------------

EFF SN GSY 100650

ELECTRICAL PARTS LIST AND SCHEMATIC CHANGES

CHANGE TO:

- A13 670-1876-01 CKT BOARD ASSY: A & B TRIGGER SOURCE SWITCH
- S130 670-1876-01 CKT BOARD ASSY: A & B TRIGGER SOURCE SWITCH

REMOVE:

- A14 670-1876-00 CKT BOARD ASSY: B TRIGGER SOURCE SWITCH
- S140 670-1876-00 CKT BOARD ASSY: B TRIGGER SOURCE SWITCH
- DS141 150-0048-01 LAMP, INCAND:5V,0.06A,SEL

ADD:

- R131 317-0120-00 RES., FXD, CMPSN:12 OHM,5%,0.125W (2 PER)

DIAGRAM 1 CALIBRATOR AND FRONT PANEL - Partial

(A & B TRIGGER SOURCE boards are identical)

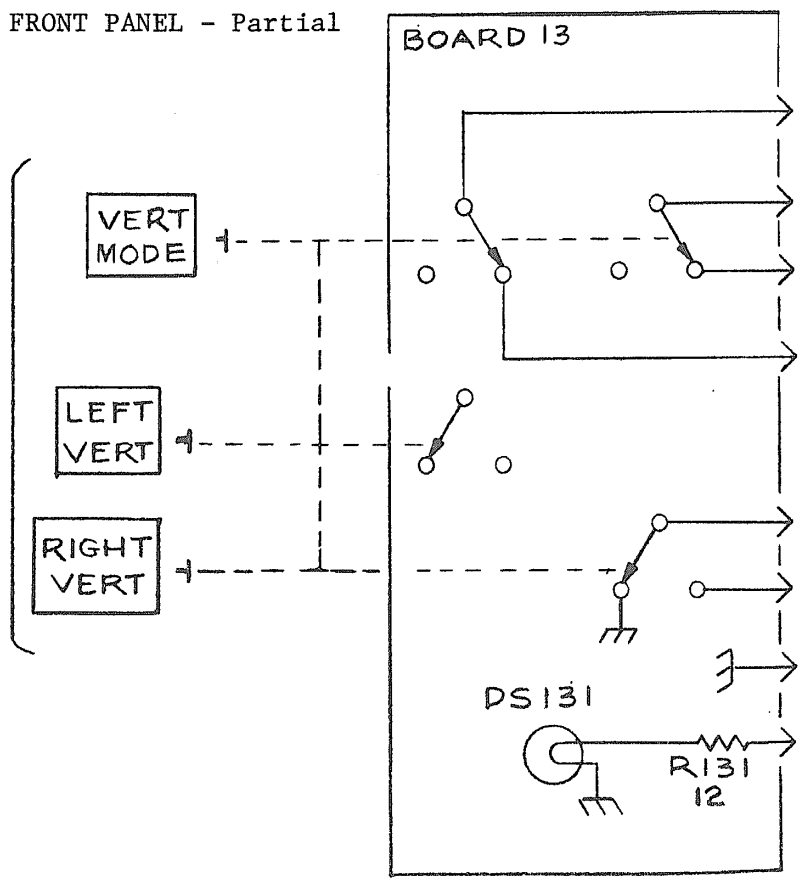



TEKTRONIX®

committed to
technical excellence

MANUAL CHANGE INFORMATION

PRODUCT 7704A SERVICE

CHANGE REFERENCE M32489

070-1260-00

DATE 5-17-78

CHANGE:

DESCRIPTION

EFF SN Gsy 100660

ELECTRICAL PARTS LIST CHANGES

CHANGE TO:

Q3220 151-0136-03 TRANSISTOR:SILICON,NPN,2N3053,SEL

Q32143 151-0136-03 TRANSISTOR:SILICON,NPN,2N3053,SEL

Q3220 and Q32143 are shown on diagram 9 LOW-VOLTAGE REGULATORS.



MANUAL CHANGE INFORMATION

PRODUCT 7704A
070-1260-00

CHANGE REFERENCE M32511
DATE 3-22-78

CHANGE:	DESCRIPTION
---------	-------------

EFF SN B210000

ELECTRICAL PARTS LIST AND SCHEMATIC CHANGES

CHANGE TO:

- | | | |
|-------|-------------|-----------------------------------|
| A31 | 670-1887-02 | CKT BOARD ASSY:RECTIFIER |
| C3168 | 290-0769-00 | CAP.,FXD,ELCTLT:10UF,20%,100V |
| C3170 | 290-0769-00 | CAP.,FXD,ELCTLT:10UF,20%,100V |
| C3172 | 290-0747-00 | CAP.,FXD,ELCTLT:100UF,+50-10%,25V |
| C3173 | 290-0770-00 | CAP.,FXD,ELCTLT:100UF,+50-10%,25V |
| C3174 | 290-0747-00 | CAP.,FXD,ELCTLT:100UF,+50-10%,25V |
| C3175 | 290-0770-00 | CAP.,FXD,ELCTLT:100UF,+50-10%,25V |
| C3178 | 290-0747-00 | CAP.,FXD,ELCTLT:100UF,+50-10%,25V |
| C3181 | 290-0747-00 | CAP.,FXD,ELCTLT:100UF,+50-10%,25V |

The above parts are located on the RECTIFIER circuit board and shown on diagram 8 INVERTERS/RECTIFIERS.



TEKTRONIX®

committed to
technical excellence

MANUAL CHANGE INFORMATION

PRODUCT 7704A SERVICE

CHANGE REFERENCE M31511

070-1260-00

DATE 7-12-78

CHANGE:

DESCRIPTION

EFF SN B204876

ELECTRICAL PARTS LIST AND SCHEMATIC CHANGES

CHANGE TO:

A25	670-1884-04	CKT BOARD ASSY:LOGIC
C2560	290-0782-00	CAP., FXD, ELCTLT:4.7UF,+75-10%,35V
C2562	290-0776-00	CAP., FXD, ELCTLT:22UF,+50-10%,10V
C2563	290-0782-00	CAP., FXD, ELCTLT:4.7UF,+75-10%,35V
C2565	290-0782-00	CAP., FXD, ELCTLT:4.7UF,+75-10%,35V
C2598	290-0782-00	CAP., FXD, ELCTLT:4.7UF,+75-10%,35V

The above components are shown on diagram 3 LOGIC CIRCUIT.



TEKTRONIX®
committed to
technical excellence

MANUAL CHANGE INFORMATION

PRODUCT 7704A

CHANGE REFERENCE M31698

070-1260-00

DATE 7-14-78

CHANGE:

DESCRIPTION

EFF SN B204779

ELECTRICAL PARTS LIST AND SCHEMATIC CHANGES

CHANGE TO:

A44 670-1852-04 CKT BOARD ASSY:VERTICAL AMPLIFIER

ADD:

R4426 315-0202-00 RES., FXD, CMPSN:2K OHM, 5%, 0.25W

R4426 is added from the collector of Q4420 to ground shown on diagram 12
VERTICAL AMPLIFIER.

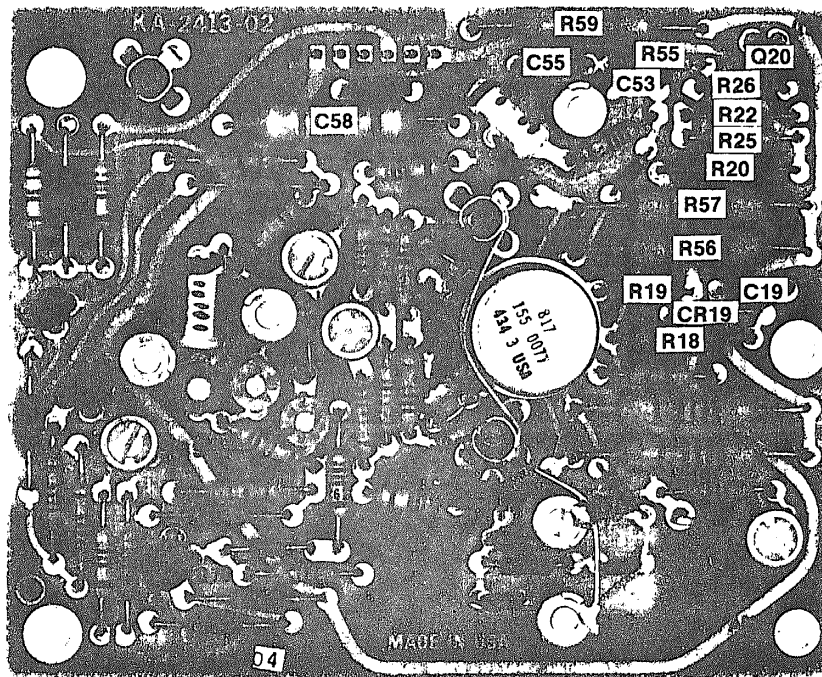

A44 ASSEMBLY (670-1852-04) Vertical Amplifier circuit board.

The labeled components have been relocated as shown above.

The remaining components are the same as Fig. 6-20 in your manual.

SECTION 6

DIAGRAMS AND CIRCUIT BOARD ILLUSTRATIONS

Symbols and Reference Designators

Electrical components shown on the diagrams are in the following units unless noted otherwise:

- Capacitors = Values one or greater are in picofarads (pF).
 Values less than one are in microfarads (μ F).
 Resistors = Ohms (Ω)

Symbols used on the diagrams are based on USA Standard Y32.2-1967.

Logic symbology is based on MIL-STD-806B in terms of positive logic. Logic symbols depict the logic function performed and may differ from the manufacturer's data.

The following special symbols are used on the diagrams:

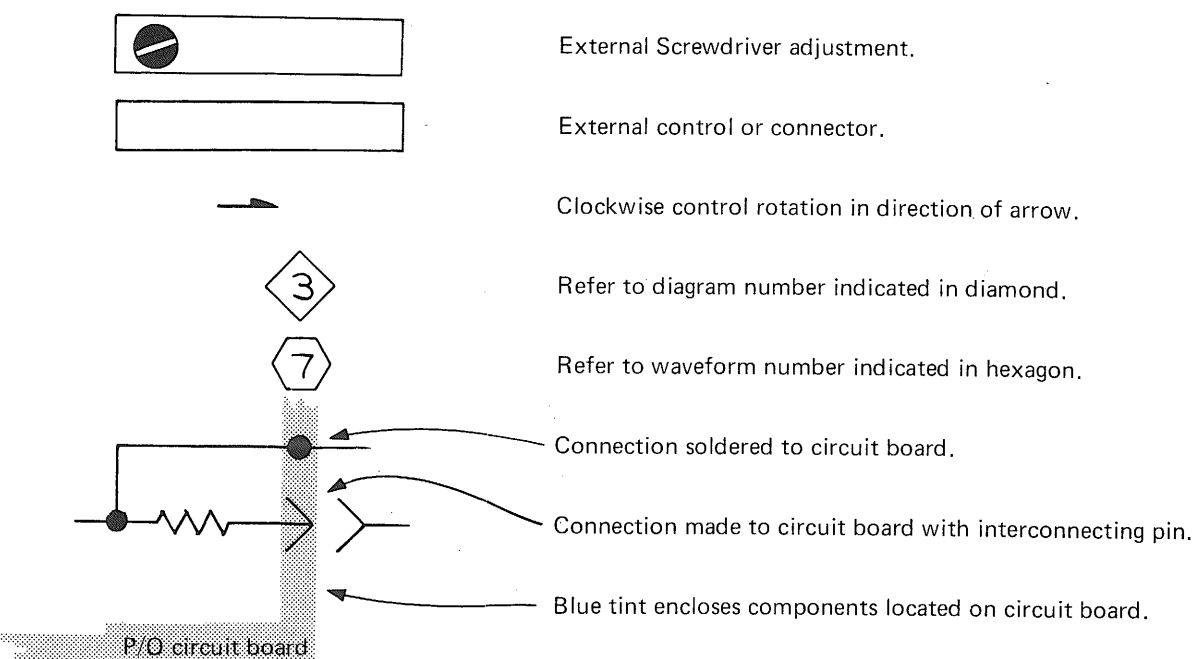

The following prefix letters are used as reference designators to identify components or assemblies on the diagrams.

A	Assembly, separable or repairable (circuit board, etc.)	LR	Inductor/resistor combination
AT	Attenuator, fixed or variable	M	Meter
B	Motor	Q	Transistor or silicon-controlled rectifier
BT	Battery	P	Connector, movable portion
C	Capacitor, fixed or variable	R	Resistor, fixed or variable
CR	Diode, signal or rectifier	RT	Thermistor
DL	Delay line	S	Switch
DS	Indicating device (lamp)	T	Transformer
F	Fuse	TP	Test point
FL	Filter	U	Assembly, inseparable or non-repairable (integrated circuit, etc.)
H	Heat dissipating device (heat sink, heat radiator, etc.)	V	Electron tube
HR	Heater	VR	Voltage regulator (zener diode, etc.)
J	Connector, stationary portion	Y	Crystal
K	Relay		
L	Inductor, fixed or variable		

Ⓐ

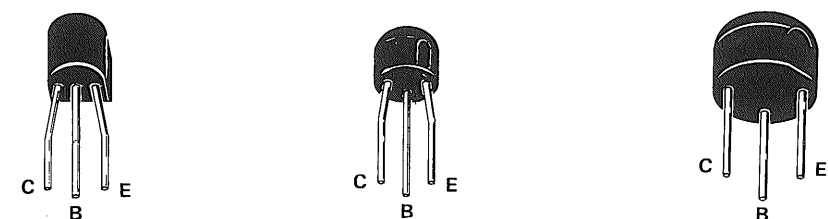

Plastic-Cased Transistors

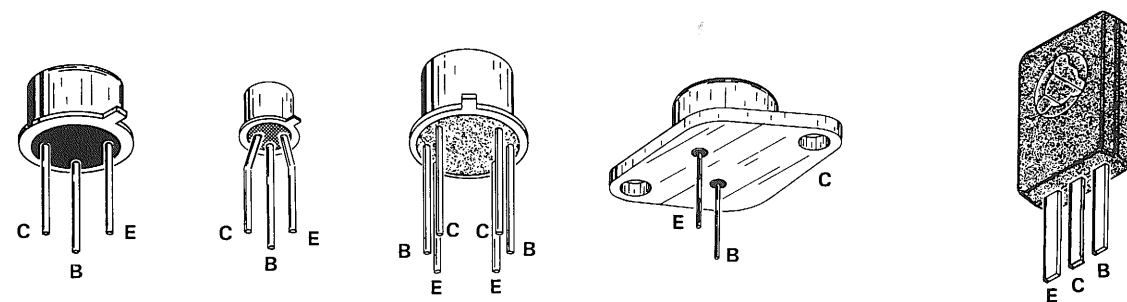

Metal-Cased Transistors

Plastic-Power Transistors

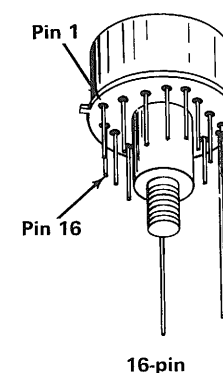

16-pin

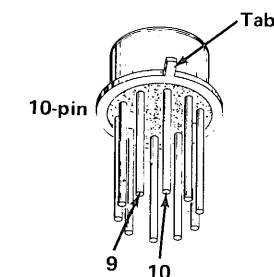

10-pin

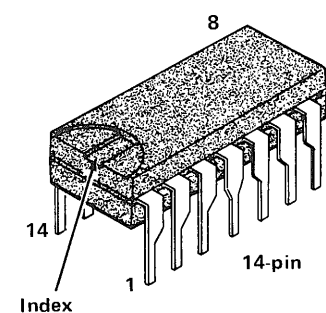

14-pin

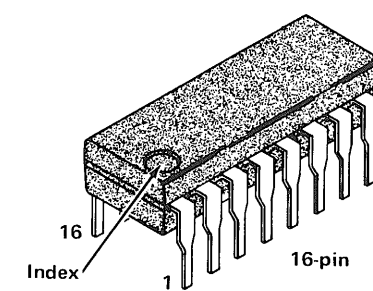

16-pin

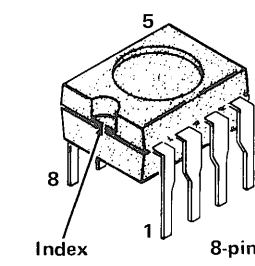

8-pin

Integrated Circuits

NOTE: Circuit board is keyed with arrow (\blacktriangleright) or dot to locate either pin 1 or tab of integrated circuit.

Fig. 6-1. Electrode configuration for semiconductors used in the 7704A.

Ⓐ

04A Service

NS

n performed

ims.

3 (integrated

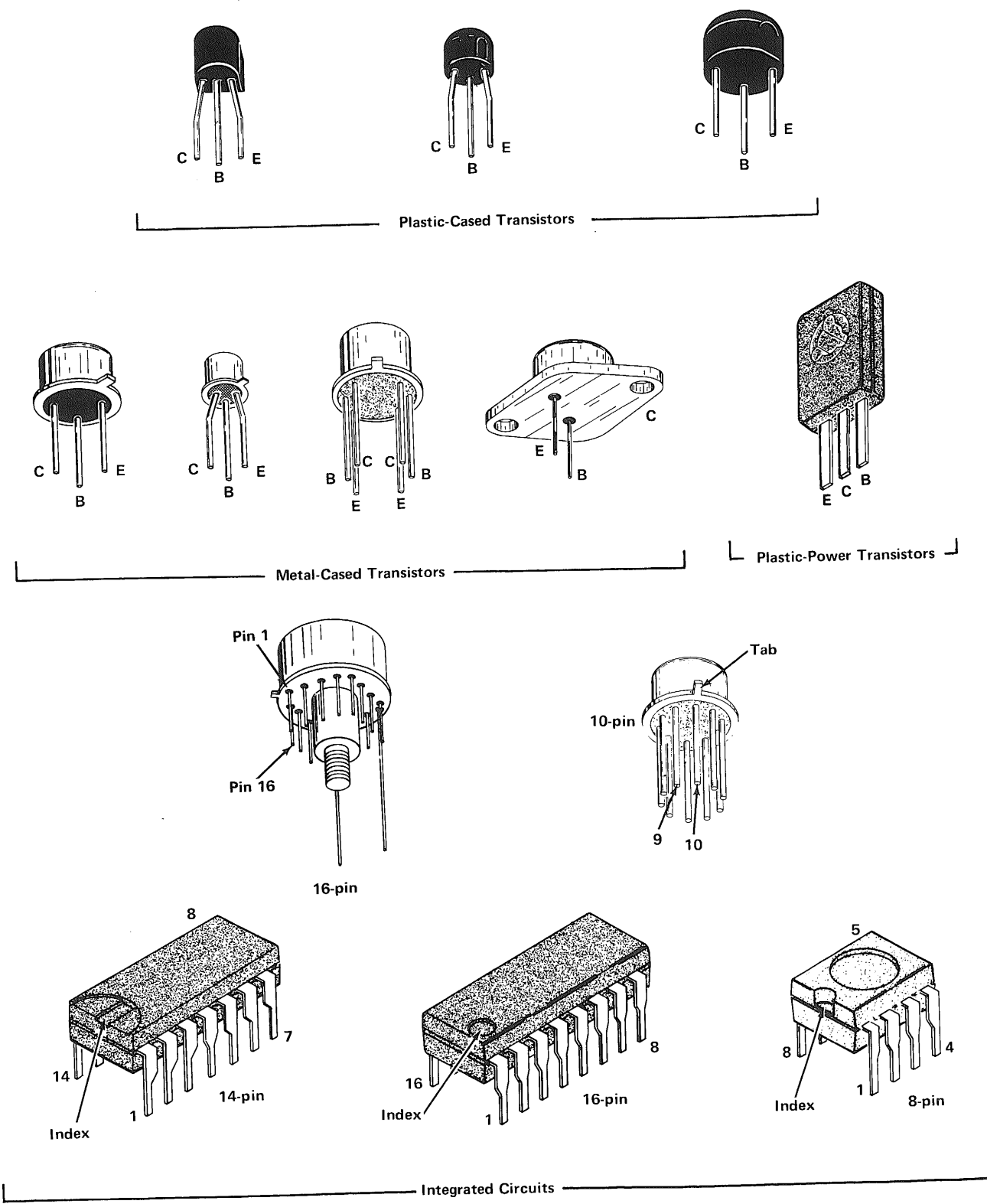

NOTE: Circuit board is keyed with arrow (>) or dot to locate either pin 1 or tab of integrated circuit.

Fig. 6-1. Electrode configuration for semiconductors used in the 7704A.

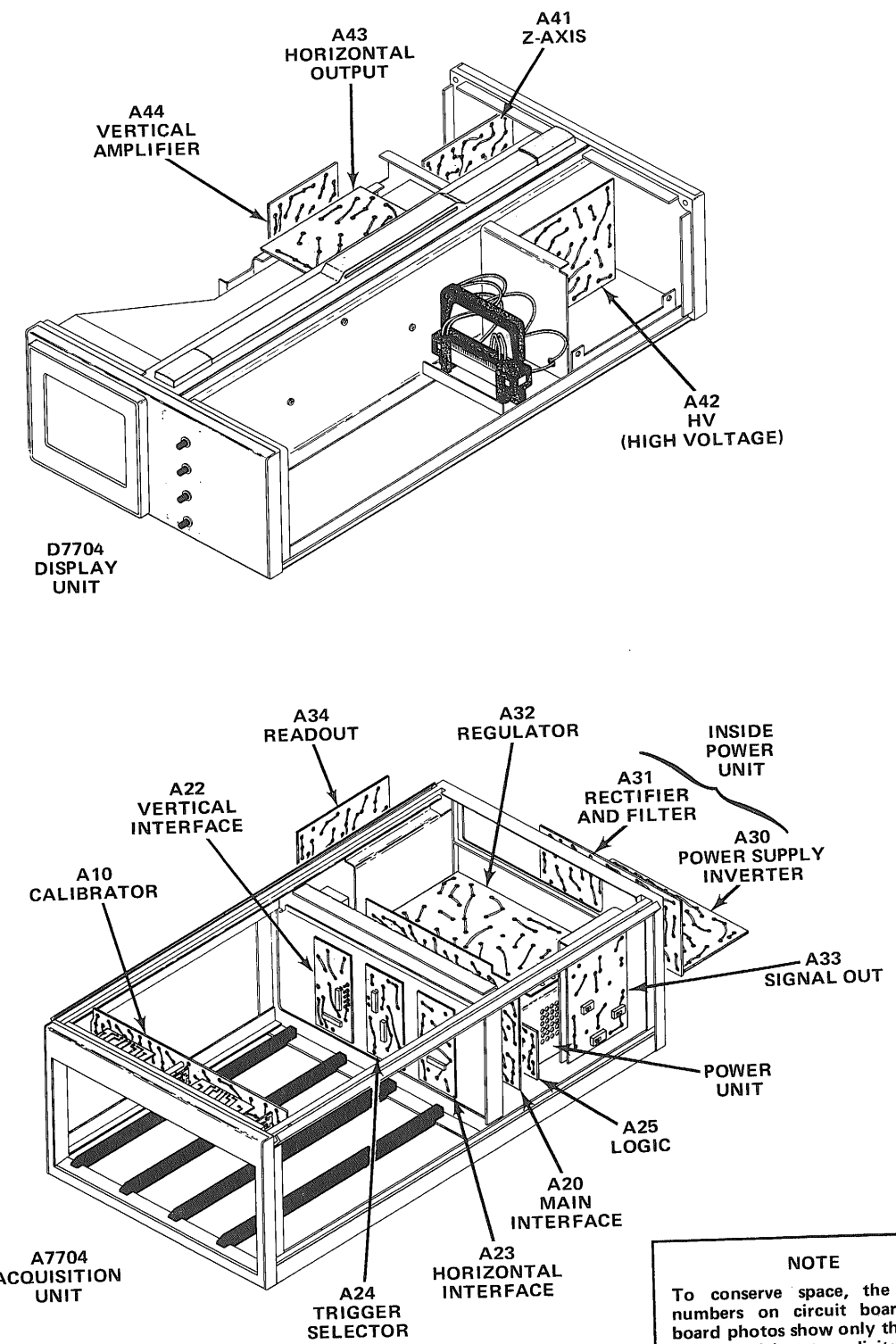

NOTE
To conserve space, the circuit numbers on circuit boards and board photos show only the letter prefix and last two digits of the complete circuit number shown in parts list and schematic (R69 = R1069, etc.).

Fig. 6-2. Location of circuit boards in the 7704A.

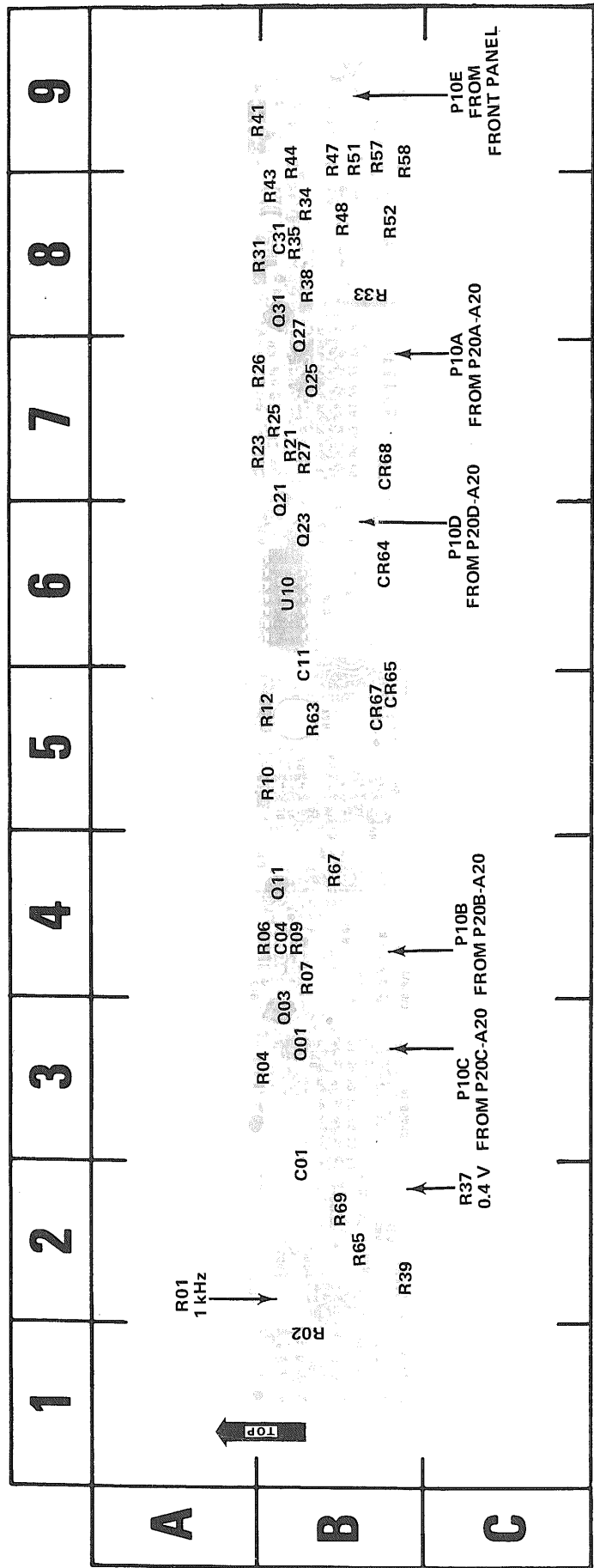
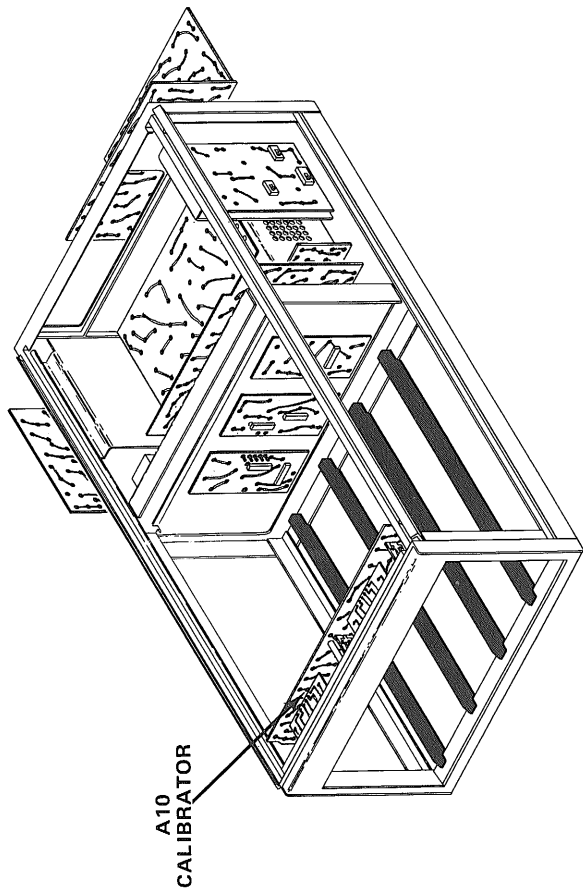

Fig. 6-3. A10 - Calibrator circuit board.

CKT NO	GRID LOC	CKT NO	GRID LOC	CKT NO	GRID LOC	CKT NO	GRID LOC	CKT NO	GRID LOC	CKT NO	GRID LOC	CKT NO	GRID LOC
C01	2B	P10A	7B	Q11	4B	R02	1B	R21	7B	R34	8B	R44	9B
C04	4B	P10B	4B	Q21	6B	R04	3B	R23	7B	R35	8B	R47	9B
C11	6B	P10C	3B	Q23	6B	R06	4B	R25	7B	R37	2B	R48	8B
C31	8B	P10D	6B	Q25	7B	R07	4B	R26	7B	R38	8B	R51	9B
CR64	6B	P10E	9B	Q27	7B	R09	4B	R27	7B	R39	2B	R52	8B
CR65	5B	Q01	3B	Q31	8B	R10	5B	R31	8B	R41	9B	R57	9B
CR67	5B	Q03	3B	R01	2B	R12	5B	R33	8B	R43	8B	R58	9B
CR68	7B											U10	6B



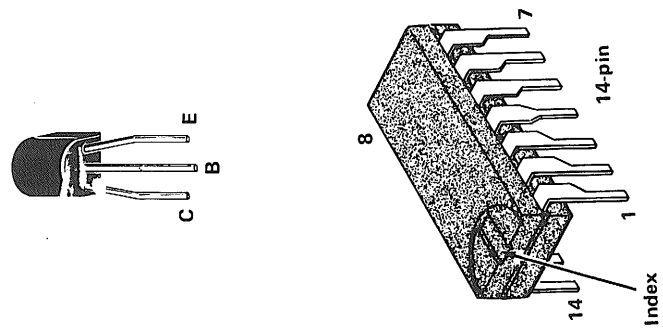
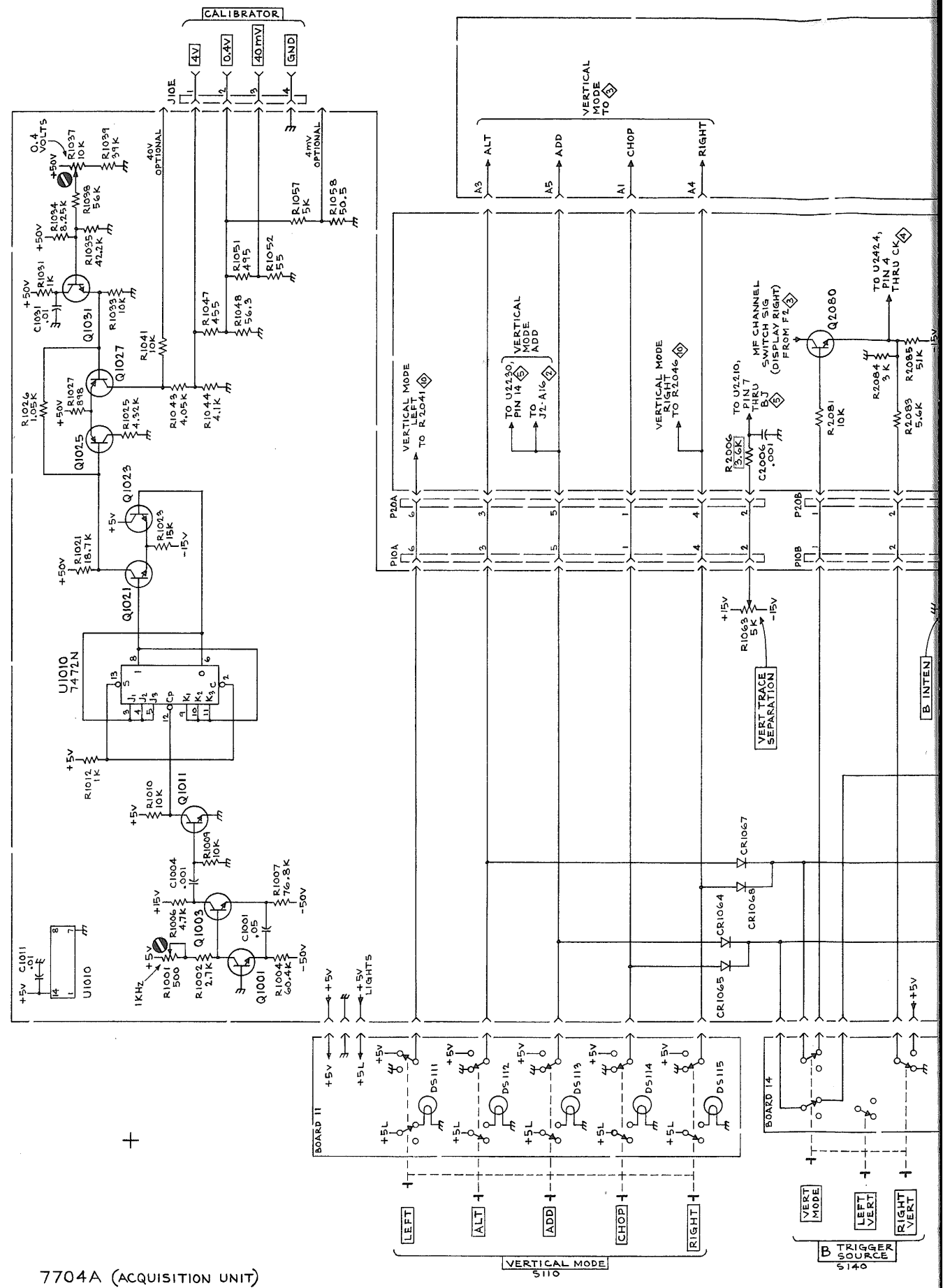
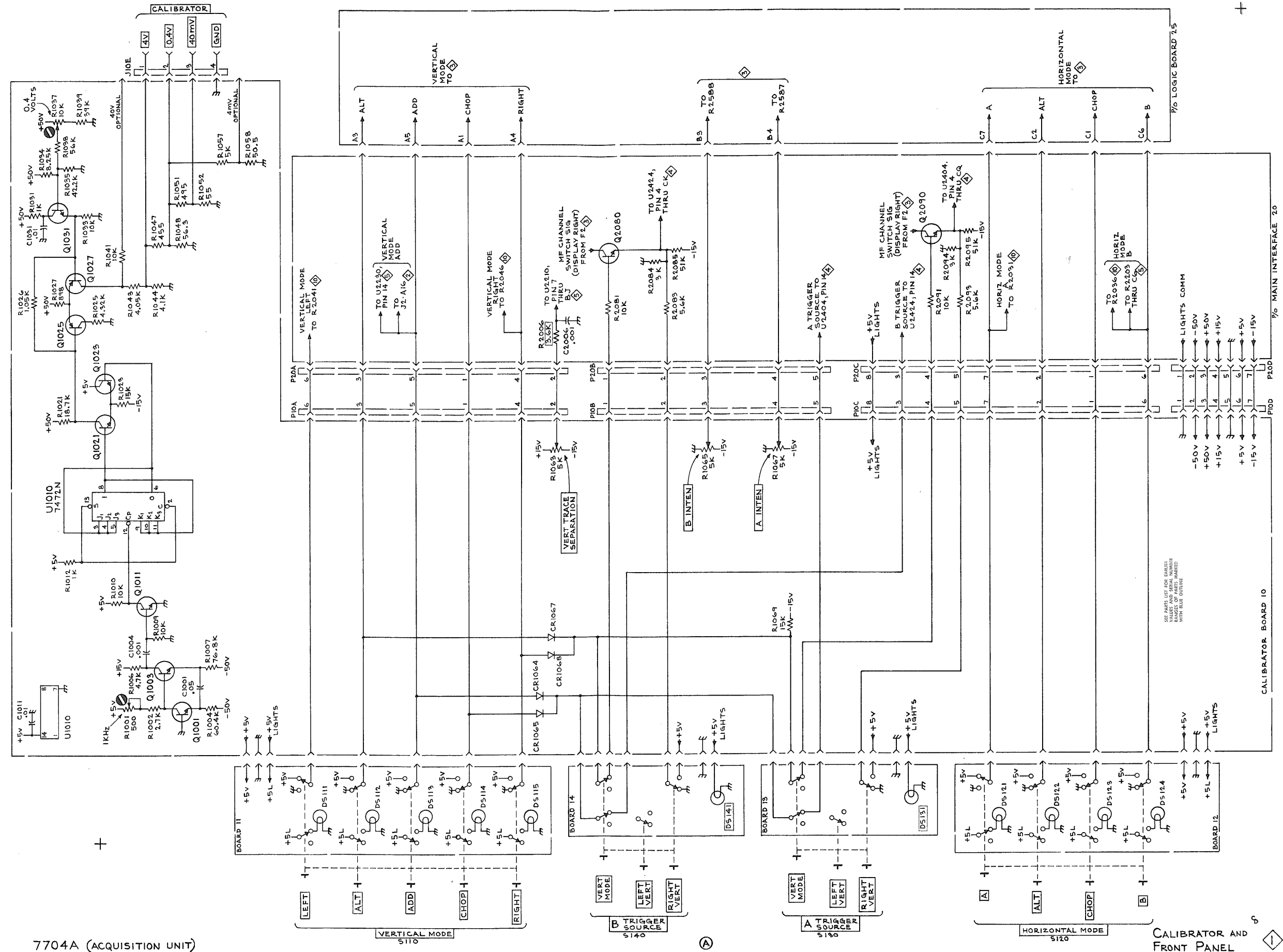

Fig. 6-4. Electrode configuration for semiconductors shown on diagram 1.



7704A (ACQUISITION UNIT)



7704A (ACQUISITION UNIT)

CALIBRATOR AND FRONT PANEL

GRID LOCATOR

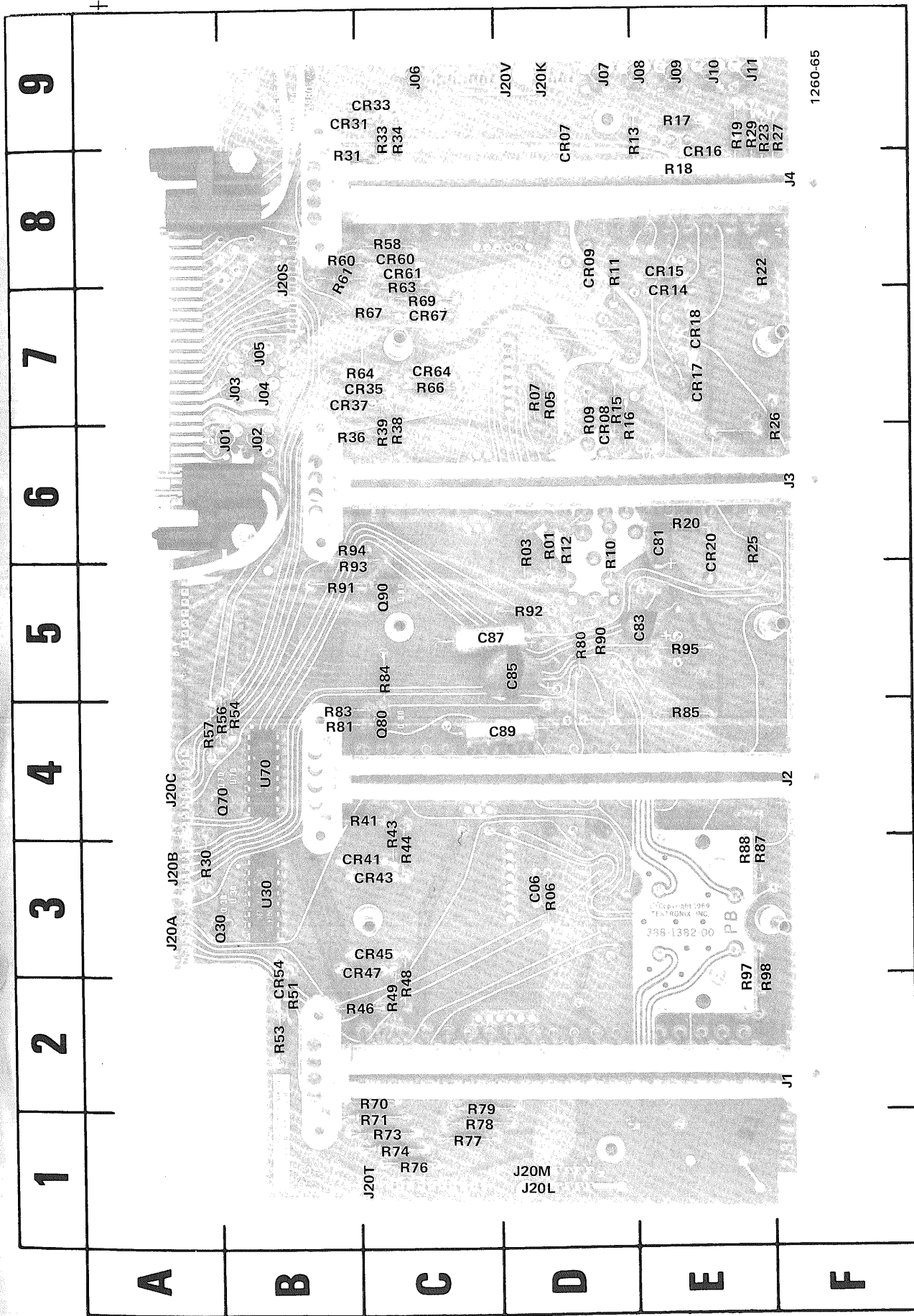
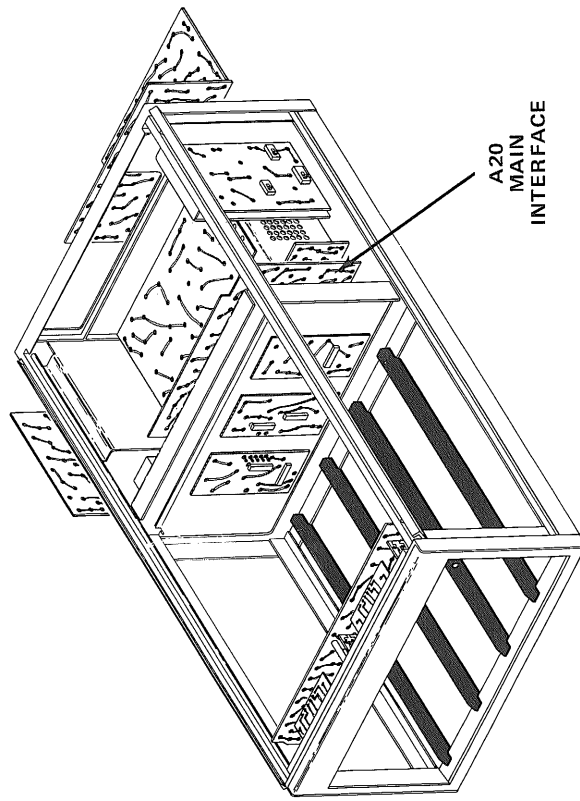

Fig. 6-5. A20 - Main Interface circuit board.

CKT NO	GRID/CKT LOC NO	GRID/CKT LOC NO	GRID/CKT LOC NO	GRID/CKT LOC NO	GRID/CKT LOC NO	GRID/CKT LOC NO	GRID/CKT LOC NO	GRID/CKT LOC NO	GRID/CKT LOC NO	GRID/CKT LOC NO					
C06	3D	CR37	7C	J02	6B	J20T	1C	R12	6D	R36	6B	R61	8B	R83	4B
C81	6E	CR41	3C	J03	7B	J20V	9D	R13	9E	R38	6C	R63	7C	R84	5C
C83	5E	CR43	3C	J04	7B	Q30	3A	R15	7D	R39	6C	R64	7C	R85	4E
C85	5D	CR45	3C	J05	7B	O70	4A	R16	6E	R41	4C	R66	7C	R87	3E
C87	5D	CR47	3C	J06	9C	O80	4C	R17	9E	R43	3C	R67	7C	R88	3E
C89	4D	CR54	2B	J08	9E	O90	5C	R18	8E	R44	3C	R69	7C	R90	5D
CR07	9D	CR60	8C	J10	9E	R01	6D	R20	6E	R46	3C	R70	2C	R91	5B
CR08	8E	CR64	7C	J11	9E	R03	6D	R22	8F	R48	3C	R71	1C	R92	5D
CR14	8E	CR67	7C	J20A	3A	R05	6D	R23	9E	R49	3C	R73	1C	R93	6C
CR15	8E	J1	2F	J20B	3A	R06	7D	R25	6E	R51	2B	R74	1C	R94	6C
CR16	8E	J2	4F	J20C	4A	R07	3D	R27	9F	R53	2B	R76	1C	R95	5E
CR20	9C	J3	6F	J20K	9D	R09	7D	R29	9E	R54	4B	R77	1C	R97	2E
CR31	9C	J4	8F	J20L	1D	R10	7D	R31	8B	R55	4A	R78	1C	R98	2E
CR33	9C	J01	6B	J20M	1D	R11	5D	R33	9C	R57	4A	R79	2C	U30	3B
CR35	7C			J20S	8B		8D	R34	9C	R60	8B	R81	4B	U70	4B

NOTE

To conserve space, the circuit numbers on circuit boards and board photos show only the letter prefix and last two digits of the complete circuit number shown in parts list and schematic (R69 = R1069, etc.).



CKT NO	GRID/CKT LOC NO	GRID/CKT LOC NO	GRID/CKT LOC NO	GRID/CKT LOC NO	GRID/CKT LOC NO	GRID/CKT LOC NO	GRID/CKT LOC NO	GRID/CKT LOC NO	GRID/CKT LOC NO	GRID/CKT LOC NO	GRID/CKT LOC NO	GRID/CKT LOC NO			
C06	3D	CR37	7C	J02	6B	J20T	1C	R12	6D	R36	6B	R61	8B	R83	4B
C81	6E	CR41	3C	J03	7B	J20V	9D	R13	9E	R38	6C	R63	7C	R84	5C
C83	5E	CR43	3C	J04	7B		7D	R15	7D	R39	6C	R64	7C	R85	4E
C85	5D	CR45	3C	J05	7B	Q30	3A	R16	6E	R41	4C	R66	7C	R87	3E
C87	5D	CR47	3C	J06	9C	Q70	4A	R17	9E	R43	3C	R67	7C	R88	3E
C89	4D	CR54	2B	J08	9E	Q80	4C	R18	8E	R44	3C	R69	7C	R90	5D
CR07	9D	CR60	8C	J09	9E	Q90	5C	R20	6E	R46	3C	R70	2C	R91	5B
CR08		CR61	8C	J10	9E		9E	R22	8F	R48	3C	R71	1C	R92	5D
CR14	8E	CR64	7C	J11	9E	R01	6D	R23	9E	R49	3C	R73	1C	R93	6C
CR15		CR67	7C	J20A	3A	R03	6D	R25	6E	R51	2B	R74	1C	R94	6C
CR16	8E	J1	2F	J20C	4A	R05	7D	R27	9F	R53	2B	R76	1C	R95	5E
CR20	6E	J2	4F	J20K	9D	R06	3D	R29	9E	R54	4B	R77	1C	R97	2E
CR31	9C	J3	6F	J20L	1D	R07	7D	R30	3A	R56	4A	R78	1C	R98	2E
CR33	9C	J4	8F	J20M	1D	R09	7D	R31	8B	R57	4A	R79	2C	U30	3B
CR35	7C	J01	6B	J20S	8B	R10	5D	R33	9C	R58	8C	R80	5D	U70	4B
						R11	8D	R34	9C	R60	8B	R81	4B		

NOTE

To conserve space, the circuit numbers on circuit boards and board photos show only the letter prefix and last two digits of the complete circuit number shown in parts list and schematic (R69 = R1069, etc.).

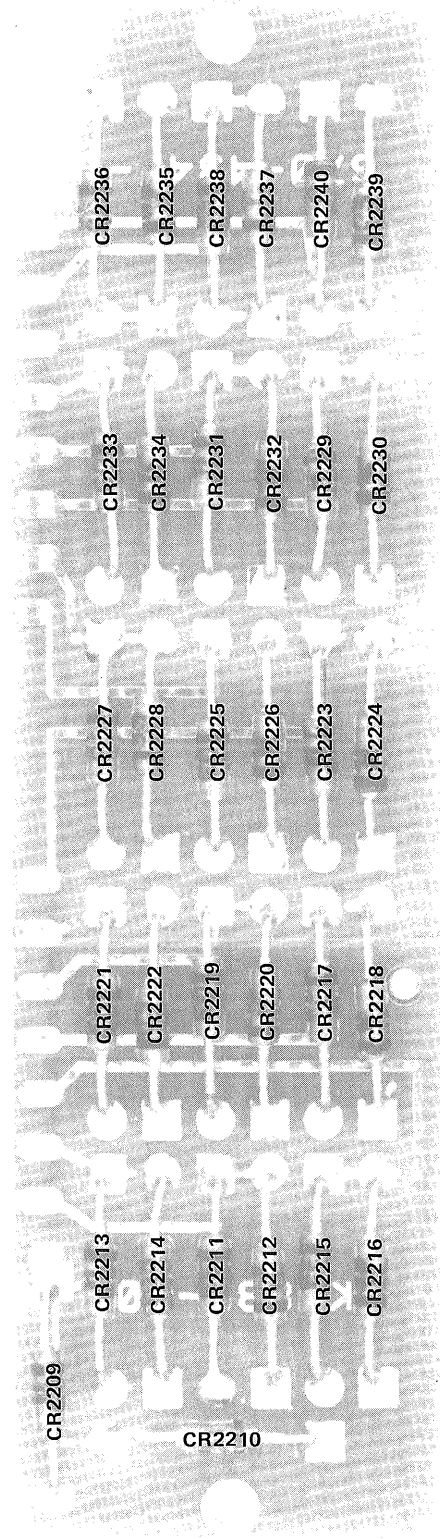
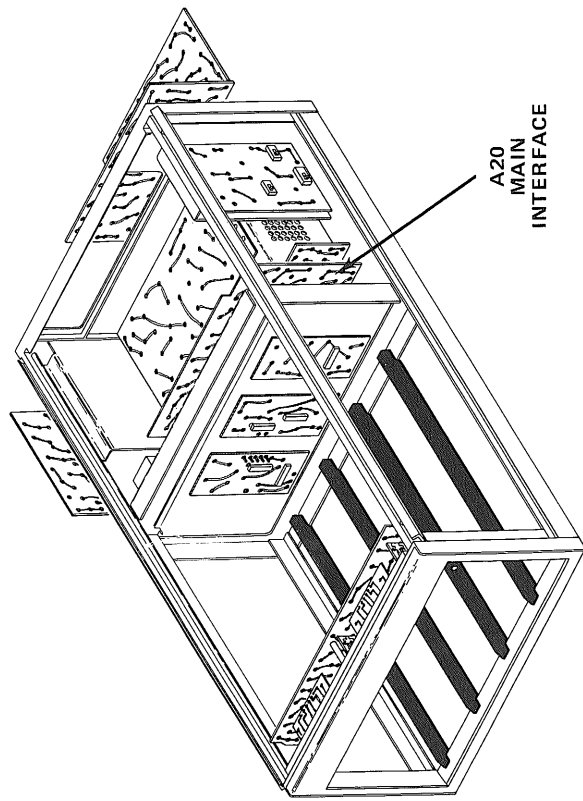

1260-111

Fig. 6-5A. A51—Protection circuit board assembly.
(Eff. SN B160000 — up)

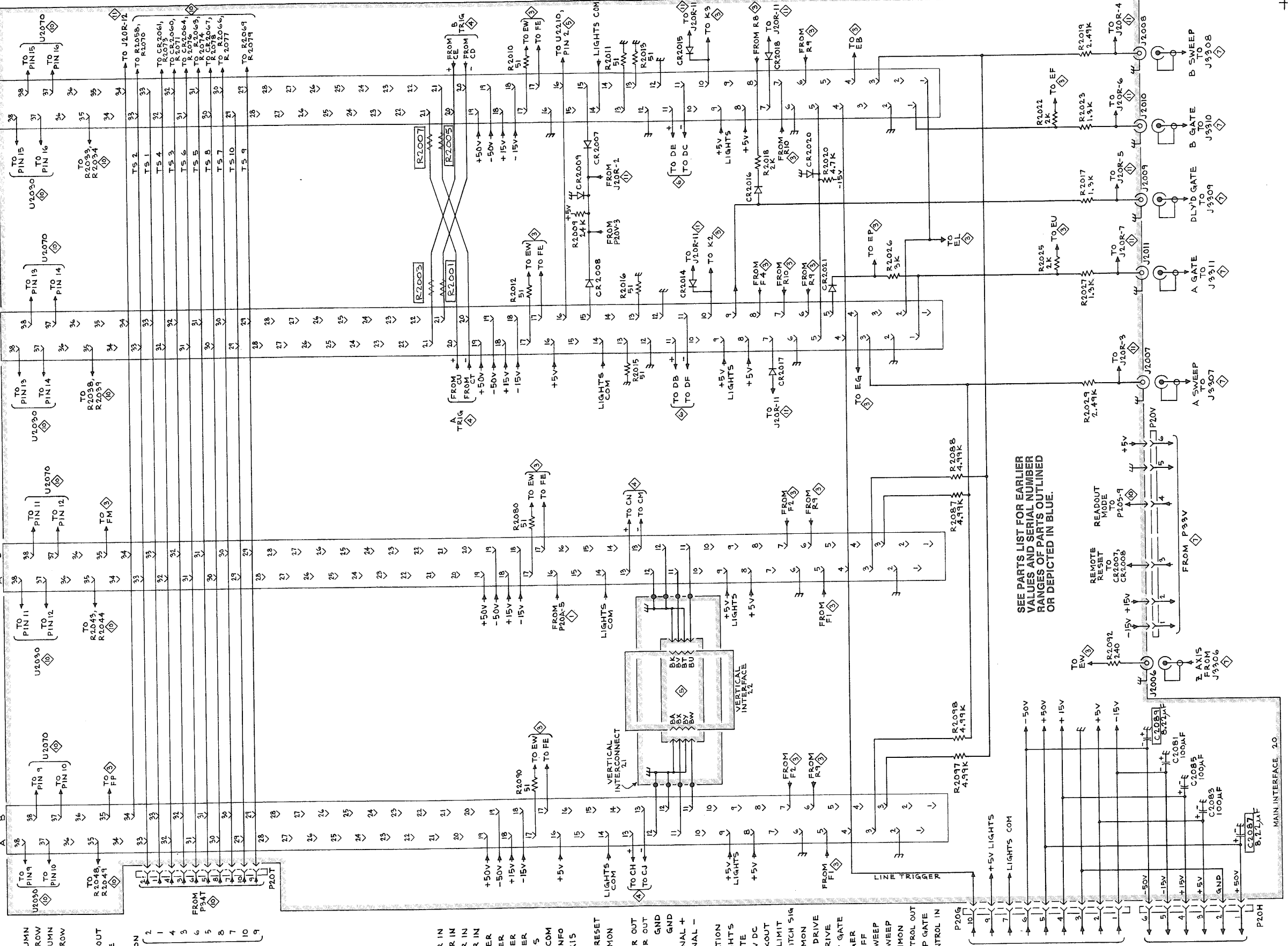

CH 2 COLUMN ANALOG DATA
 CH 1 COLUMN ANALOG DATA
 FORCE READOUT PLUG-IN MODE
 DVM COMMON
 TIMESLOT PULSE LINES
 PZOT

REV. B, MAY 1976
 1260-66

+ AUX TRIGGER IN
 - AUX TRIGGER IN
 + TRIGGER IN
 - TRIGGER IN
 +50V POWER
 -50V POWER
 +15V POWER
 -15V POWER
 AUX Z AXIS
 AUX Z AXIS COM
 MIF MODE INFO
 AUX Y AXIS

SINGLE SWEEP RESET
 LIGHTS COMMON
 + TRIGGER OUT
 - TRIGGER OUT
 GND
 GND
 SIGNAL +
 SIGNAL -

X-Y COMPENSATION
 +5V LIGHTS
 DELAY GATE
 +5V DC
 SWEEP LOCKOUT
 INTENSITY LIMIT
 MF CHANNEL SWITCH SIG
 CHOP COMMON
 ALTERNATE DRIVE
 CHOP DRIVE
 AUX SWEEP GATE
 LINE TRIGGER
 HOLD OFF
 A SWEEP
 B SWEEP
 UTILITY COMMON
 DELAY MODE CONTROL OUT
 SWEEP GATE
 DELAY MODE CONTROL IN

SEE PARTS LIST FOR EARLIER VALUES AND SERIAL NUMBER RANGES OF PARTS OUTLINED OR DEPICTED IN BLUE.

MAIN INTERFACE

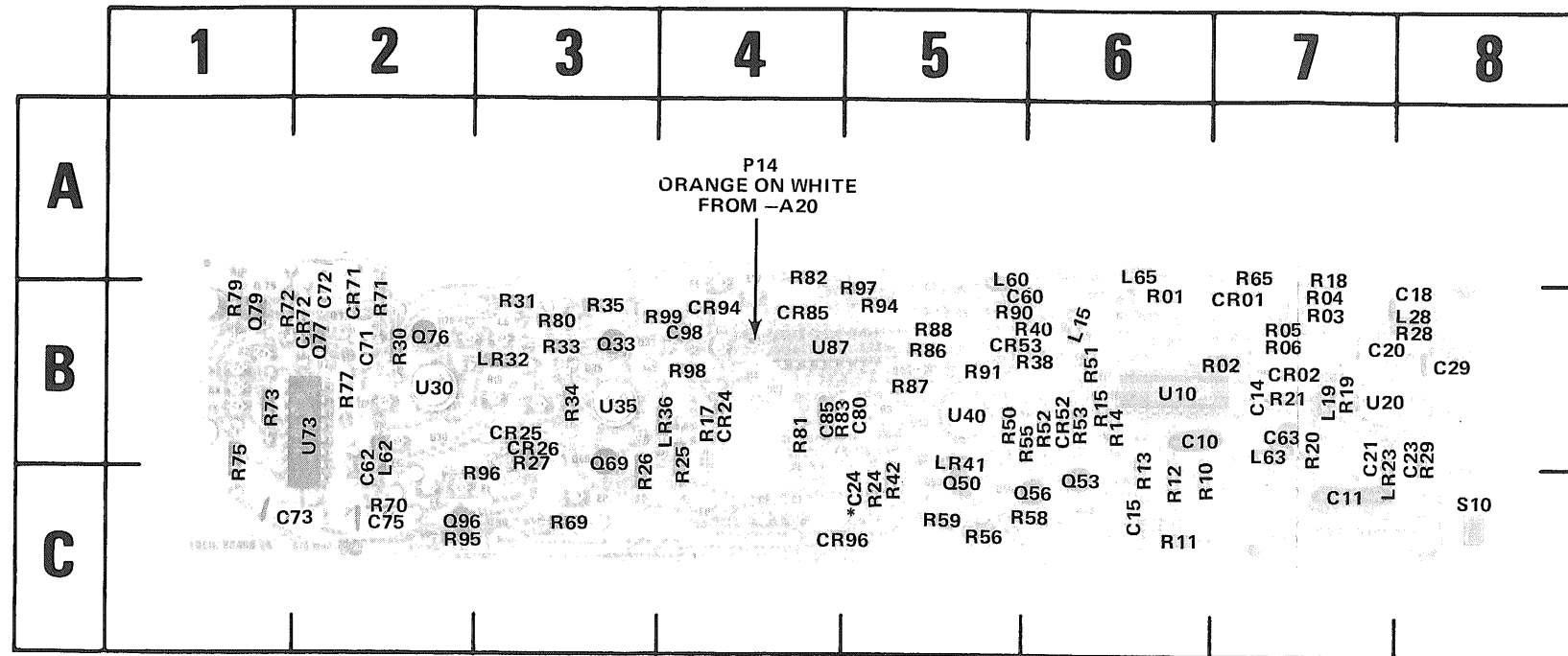

Fig. 6-6. A25 - Logic circuit board.

**Relocated to back of board.

*See Parts List for serial number ranges.

CKT NO	GRID LOC	CKT NO	GRID LOC	CKT NO	GRID LOC	CKT NO	GRID LOC	CKT NO	GRID LOC	CKT NO	GRID LOC	CKT NO	GRID LOC	CKT NO	GRID LOC
C10	6B	C85	4B	L28	8B	Q56	6C	R14	6B	R34	3B	R71	2B	R95	2C
C11	7C	C98	4B	L60	5A	Q69	3B	R15	6B	R35	3B	R72	1B	R96	3C
C14	7B			L62	2B	Q76	2B	R17	4B	R38	6B	R73	1B	R97	5B
C15	6C	CR01	7B	L63	7B	Q77	2B	R18	7A	R40	6B	R75	1B	R98	4B
C18 *	8B	CR02	7B	L65	6A	Q79	1B	R19	7B	R42	5C	R77	2B	R99	4B
C20	7B	CR25	3B			Q96	2C	R20	7B	R50	5B	R79	1B		
C21	7B	CR26	3B	LR23	7B			R21	7B	R51	6B	R80	3B	S10	8C
C23	8B	CR52	6B	LR32	3B	R01	6B	R24	5C	R52	6B	R81	4B		
C24	5C	CR53	5B	LR36	4B	R02	7B	R25	4B	R53	6B	R82	4A	U10	6B
C29 *	8B	CR71	2B	LR41	5B	R03	7B	R26	3C	R55	6B	R83	4B	U20	7B
C60	5B	CR72	2B			R04	7B	R27	3B	R56	5C	R86	5B	U30	2B
C62	2B	CR85	4B	P14	4B	R05	7B	R28	8B	R58	6C	R87	5B	U35	3B
C63	7B	CR96	5C			R06	7B	R29	8B	R59	5C	R88	5B	U40	5B
C65	8B			Q33	3B	R10	6C	R30	2B	R65 **	7A	R90*	5B	U73	2B
C71	2B	L15	6B	Q50	5C	R11	6C	R31	3B	R69	3C	R91*	5B	U87	4B
C72	2B	L19	7B	Q63	6C	R12	6C	R33	3B	R70	2C	R94	5B		
C73	2C					R13	6C								
C75	2C														

NOTE

To conserve space, the circuit numbers on circuit boards and board photos show only the letter prefix and last two digits of the complete circuit number shown in parts list and schematic (R69 = R1069, etc.).

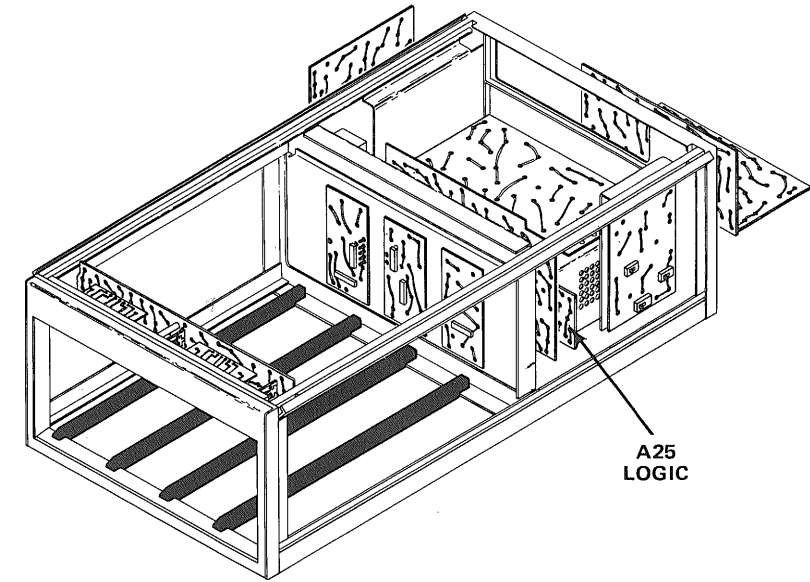

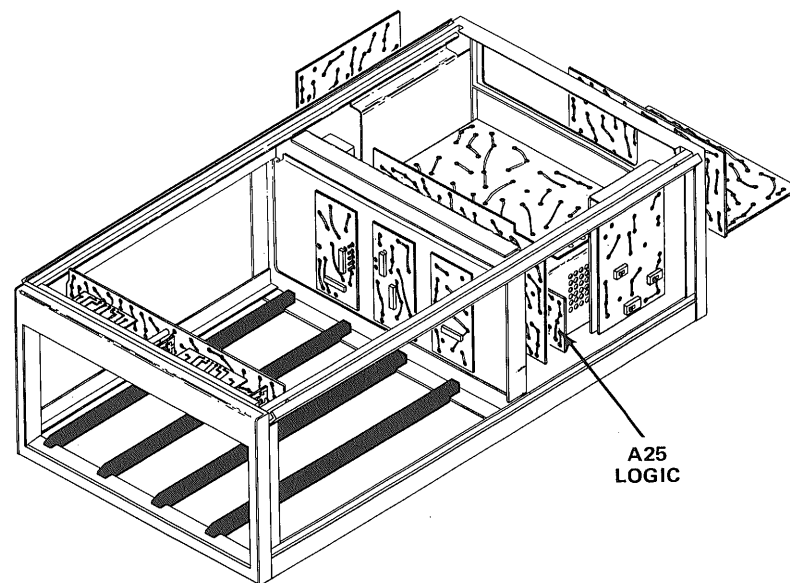
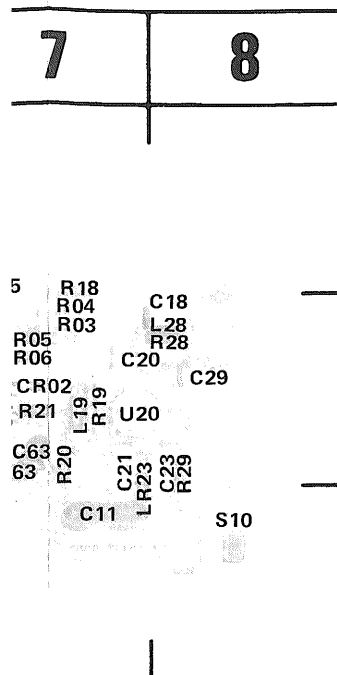

for
anges.

CKT NO	GRID LOC
R95	2C
R96	3C
R97	5B
R98	4B
R99	4B
S10	8C
U10	6B
U20	7B
U30	2B
U35	3B
U40	5B
U73	2B
U87	4B

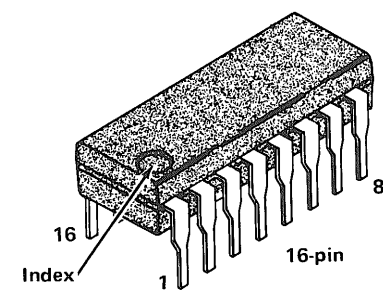
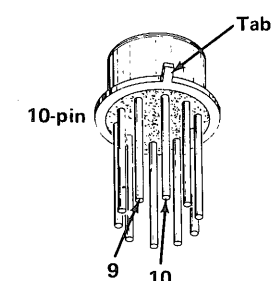
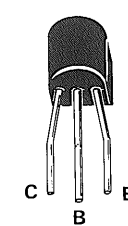
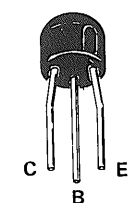

Fig. 6-7. Electrode configuration for semiconductors shown on diagram 3.

VOLTAGE AND WAVEFORM CONDITIONS

The voltages and waveforms shown on this diagram were obtained with the test set-ups and equipment listed below. These measurements are not absolute and may vary slightly between instruments.

Recommended Test Equipment

Item	Specifications	Examples of Applicable Test Equipment
Test oscilloscope	Frequency response, dc to 65 MHz; deflection factor (with 10X probe), 500 mV/division; fastest sweep rate, 500 ns/division.	a. Tektronix 7603 Oscilloscope with 7A15A Amplifier, 7B50 Time Base, and P6053A Probe, or equivalent.
Dc voltmeter (non-loading digital multimeter)	Input impedance, 10 megohms; range, 0 to 20 volts dc.	a. Tektronix 7D13 Digital Multimeter (test oscilloscope must have readout system). b. Fairchild Model 7050.

Test Set-Up

7704A Under Test: Amplifier unit installed in LEFT VERT compartment. Time-base unit installed in B HORIZ compartment. Time-base unit set for free-running sweep at 0.1-ms/division sweep rate.

Front-Panel Controls

Knob-type controls	Midrange
VERTICAL MODE	LEFT
A AND B TRIGGER SOURCE	VERT MODE
HORIZONTAL MODE	B

Test Equipment: Voltmeter common is connected to 7704A chassis ground. Test oscilloscope is internally triggered.

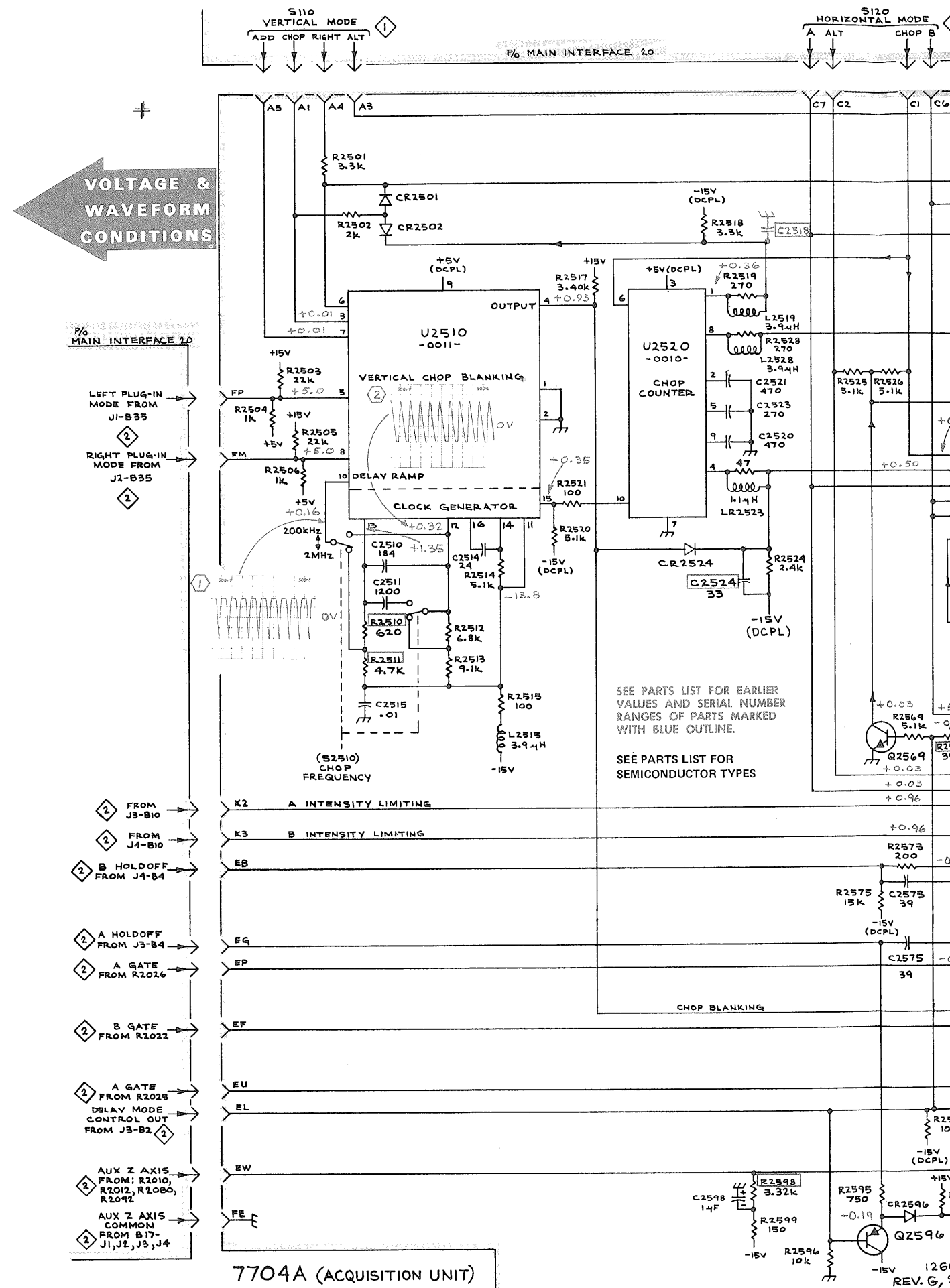

VOLTAGE & WAVEFORM CONDITIONS

- P/O MAIN INTERFACE 20
- LEFT PLUG-IN MODE FROM J1-B35
 - RIGHT PLUG-IN MODE FROM J2-B35
 - FROM J3-B10
 - FROM J4-B10
 - B HOLDOFF FROM J4-B4
 - A HOLDOFF FROM J3-B4
 - A GATE FROM R2026
 - B GATE FROM R2022
 - A GATE FROM R2025
 - DELAY MODE CONTROL OUT FROM J3-B2
 - AUX Z AXIS FROM: R2010, R2012, R2080, R2092
 - AUX Z AXIS COMMON FROM B17-J1, J2, J3, J4

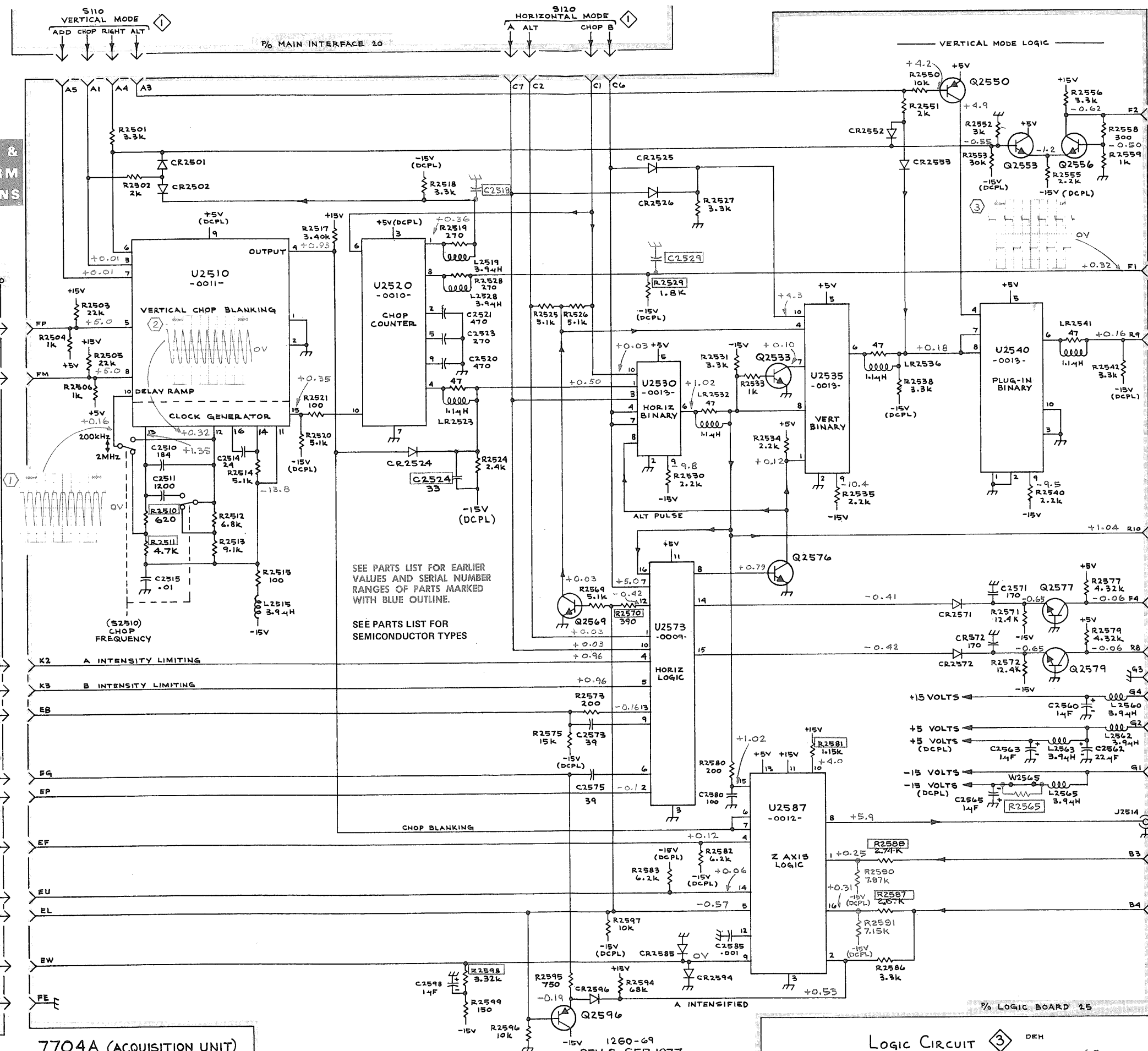

- P/O MAIN INTERFACE A20
- MF CHANNEL SWITCH SIGNAL (DISPLAY RIGHT) TO F2
 - TO J1-B7
 - TO J2-B7
 - TO J20F-2
 - TO Q2080
 - TO Q2090
 - (HI RIGHT) (LO LEFT)
 - (VERTICAL) CHOP DRIVE
 - TO J10F-1
 - TO J1-A5
 - TO J2-A5
 - (HI CH2) (LO CH1)
 - ALTERNATE DRIVE
 - TO J1-B6
 - TO J2-B6
 - TO J3-B6
 - TO J4-B6
 - TO J20R-9
 - (HI CH2) (LO CH1)
 - MF CHANNEL SWITCH SIGNAL (DISPLAY B)
 - TO R10
 - TO R10
 - TO J3-B7
 - TO J4-B7
 - TO J20R-10
 - A SWEEP LOCKOUT TO J20F-4
 - TO J3-B8
 - B SWEEP LOCKOUT TO J20R-8
 - TO J4-B8
 - +15 VOLTS
 - +5 VOLTS
 - +5 VOLTS (DCPL)
 - 15 VOLTS
 - 15 VOLTS (DCPL)
 - J2014 Z AXIS SIGNAL TO J414
 - B INTENSITY FROM R1065
 - A INTENSITY FROM R1067

7704A (ACQUISITION UNIT)

1260-69 REV. G, SEP 1977

Logic Circuit 3 DEH

6-7

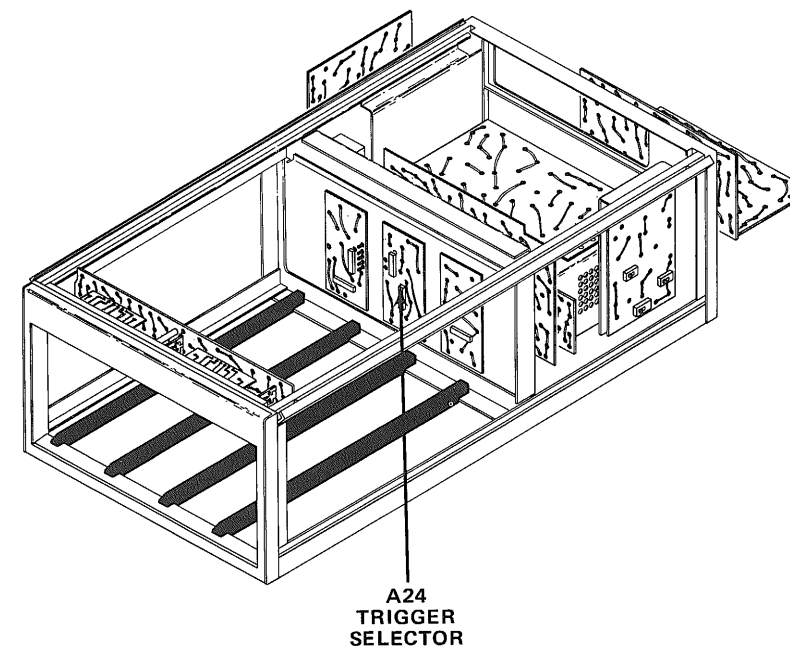
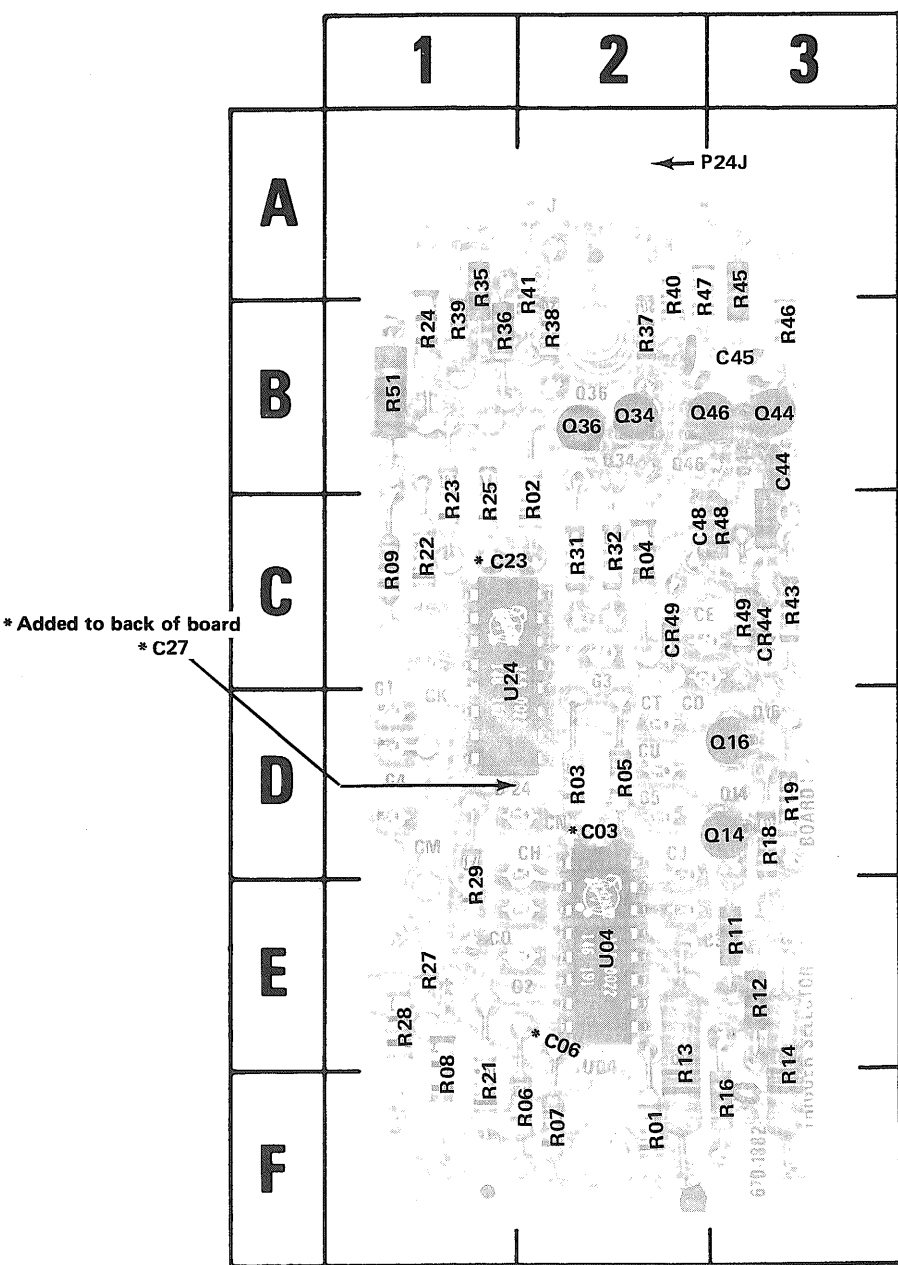

Fig. 6-8. A24 - Trigger Selector circuit board.

*See Parts List for serial number ranges.

CKT NO	GRID LOC	CKT NO	GRID LOC	CKT NO	GRID LOC	CKT NO	GRID LOC	CKT NO	GRID LOC	CKT NO	GRID LOC	CKT NO	GRID LOC	CKT NO	GRID LOC
C03	2D	Q14	3D	R03	2D	R11	3E	R21	1F	R29	1D	R39	1B	R48	3C
C06	2F	Q16	3D	R04	2C	R12	3E	R22	1C	R31	2C	R40	2A	R49	3C
C23	1C	Q34	2B	R05	2D	R13	2E	R23	1C	R32	2C	R41	2A	R51	1B
C27	1D	Q36	2B	R06	2F	R14	3E	R24	1B	R35	1B	R43	3C		
C44	3B	Q44	3B	R07	2F	R16	3F	R25	1C	R36	1B	R45	3A	U04	2E
C48	2C	Q46	3B	R08	1E	R18	3D	R27	1E	R37	2B	R46	3B	U24	1C
C54	3B			R09	1C	R19	3D	R28	1E	R38	2B	R47	2A		
CR44	3C	R01	2F												
CR49	2C	R02	2C												

VOLTAGE CONDITIONS

The voltages shown on this diagram were obtained with the test set-up and equipment listed below. These measurements are not absolute and may vary slightly between instruments.

Recommended Test Equipment

Item	Specifications	Examples of Applicable Test Equipment
Dc voltmeter (non-loading digital multimeter)	Input impedance, 10 megohms; range, 0 to 20 volts dc.	a. Tektronix 7D13 Digital Multimeter (test oscilloscope must have readout system). b. Fairchild Model 7050.

Test Set-Up

7704A Under Test: No plug-in units installed.

Front-Panel Controls

Knob-type controls	Midrange
VERTICAL MODE	LEFT
A AND B TRIGGER SOURCE	VERT MODE
HORIZONTAL MODE	B

Test Equipment: Voltmeter common is connected to 7704A chassis ground.

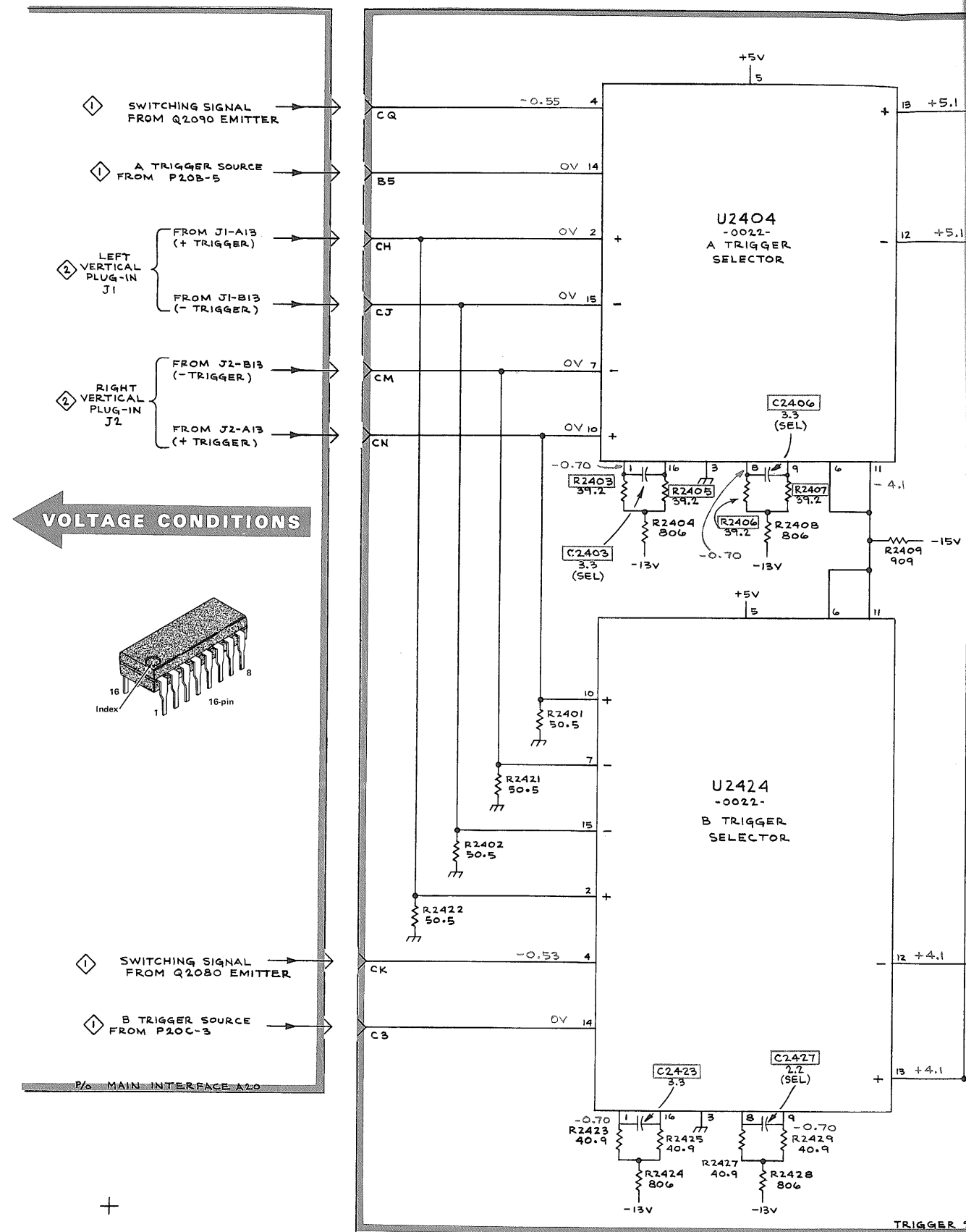

7704A (ACQUISITION UNIT)

REV.C, SEPT. 1975
1260-71

ot absolute

er (test

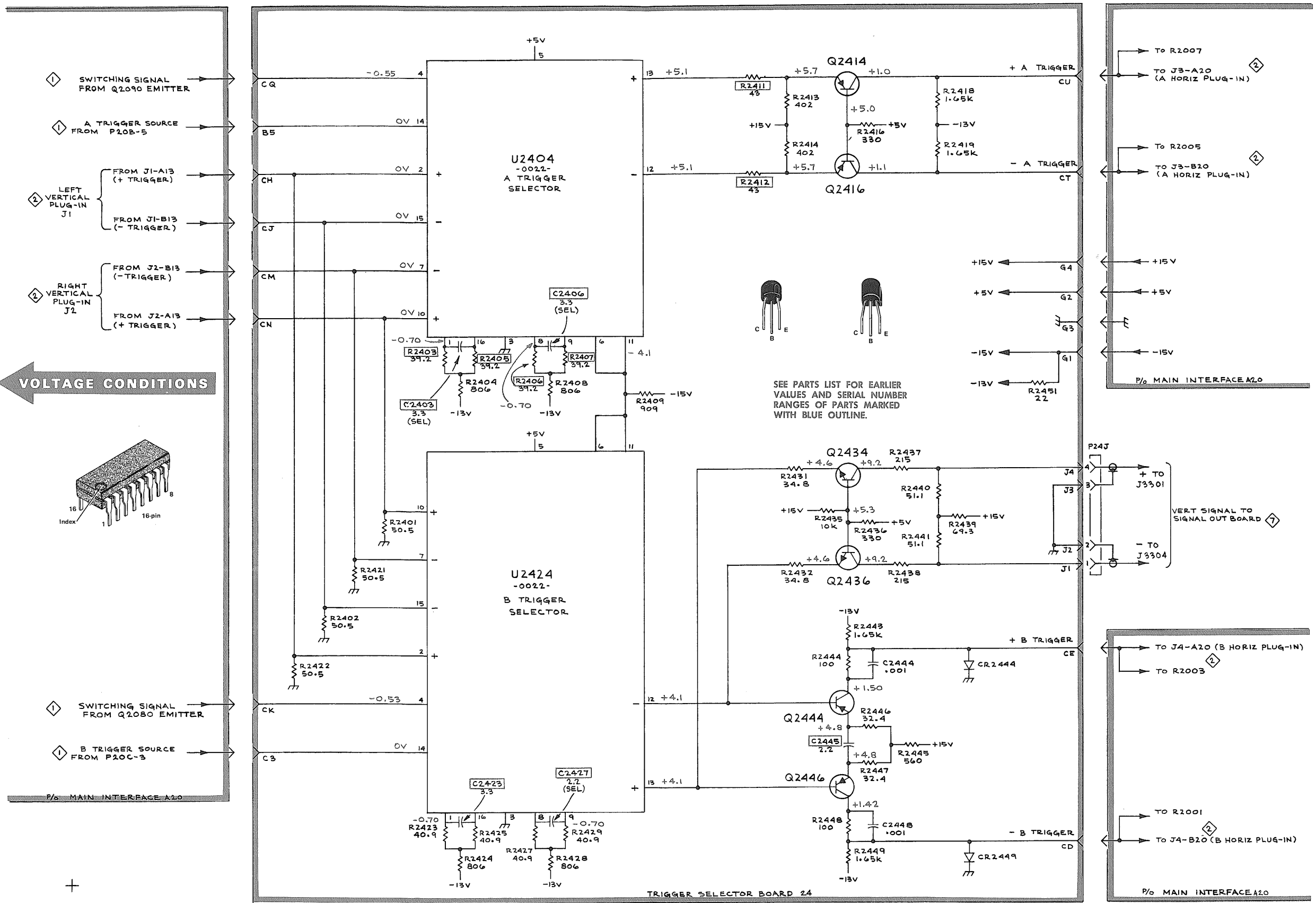

7704A (ACQUISITION UNIT)

REV.C, SEPT. 1975
1260-71

TRIGGER SELECTOR 4

DEH

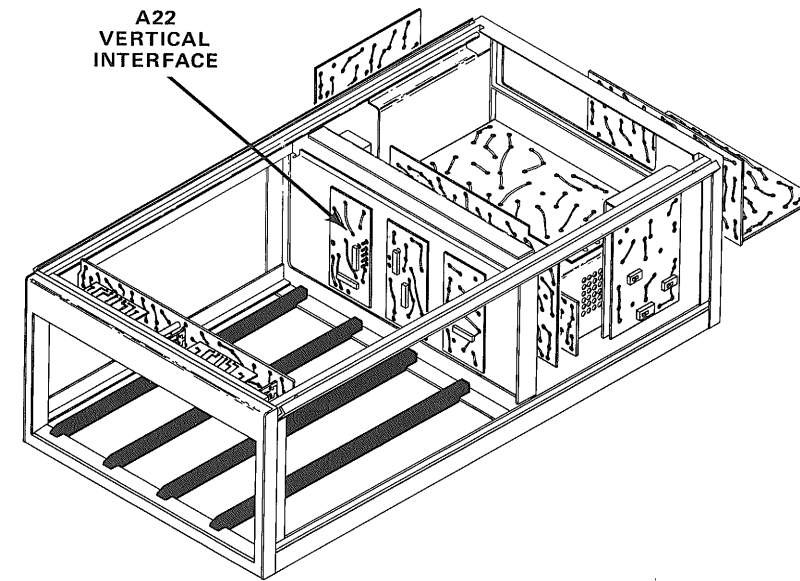
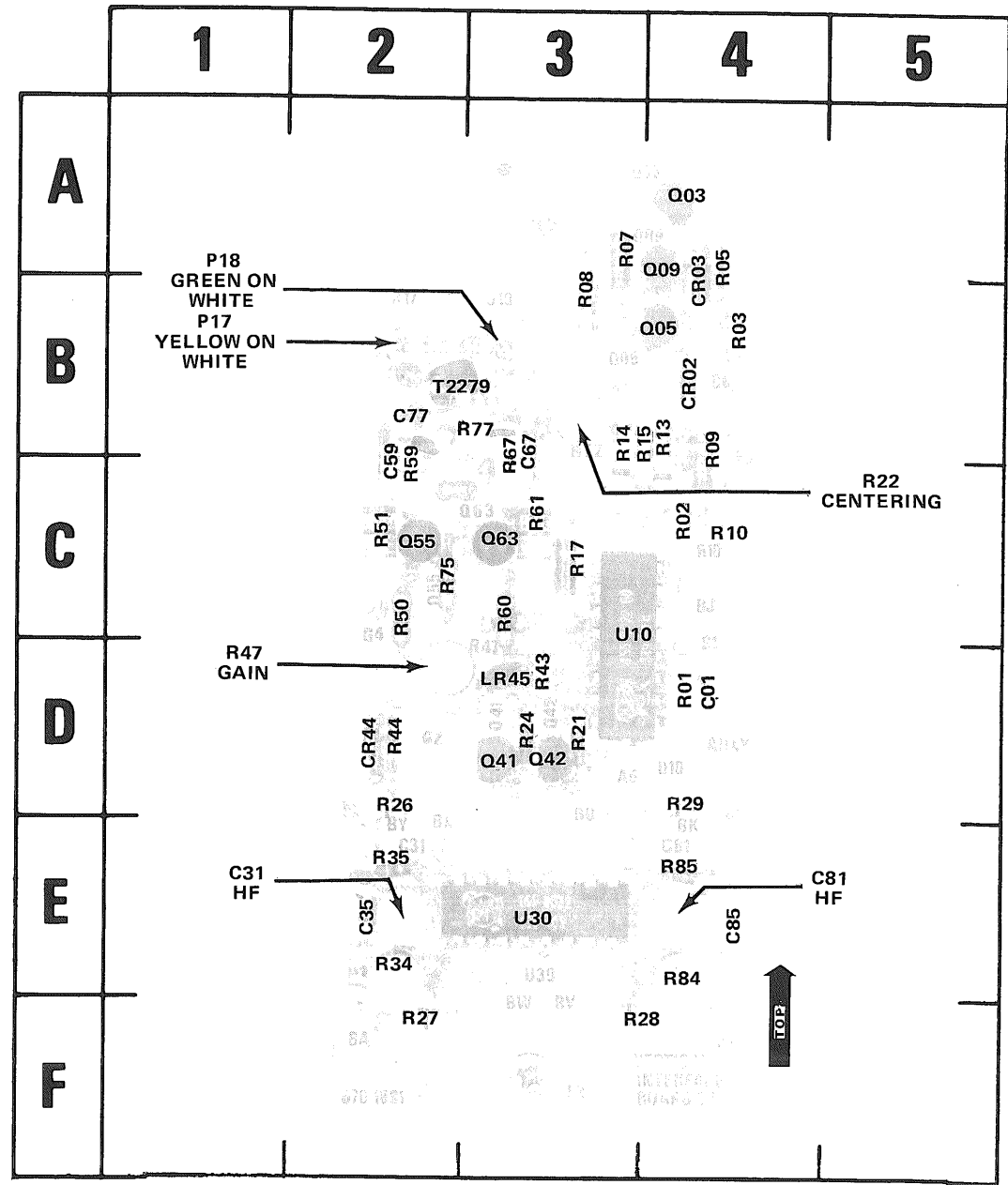

Fig. 6-9. A22 - Vertical Interface circuit board (front view).

CKT NO	GRID LOC	CKT NO	GRID LOC	CKT NO	GRID LOC	CKT NO	GRID LOC	CKT NO	GRID LOC	CKT NO	GRID LOC	CKT NO	GRID LOC	CKT NO	GRID LOC
C01	4D	CR44	2D	Q41	3D	R05	4A	R17	3C	R34	2E	R60	3C	T2279	2B
C31	2E	CR45	3D	Q42	3D	R07	3A	R21	3D	R35	2E	R61	3C		
C35	2E			Q55	2C	R08	3A	R22	3B	R43	3D	R67	3B	U10	3C
C59	2B	P17	2B	Q63	3C	R09	4B	R24	3D	R44	2D	R75	2C	U30	3E
C67	3B					R10	4C	R26	2D	R47	2D	R77	2B		
C77	2B					R13	4B	R27	2F	R50	2C	R84	4E		
C81	4E	Q03	4A	R01	4D	R14	3B	R28	4F	R51	2C	R85	4E		
C85	4E	Q05	4B	R02	4C	R15	4B	R29	4D	R59	2B				
CR02	4B	Q09	4A	R03	4B										
CR03	4A														

NOTE

To conserve space, the circuit numbers on circuit boards and board photos show only the letter prefix and last two digits of the complete circuit number shown in parts list and schematic (R69 = R1069, etc.).

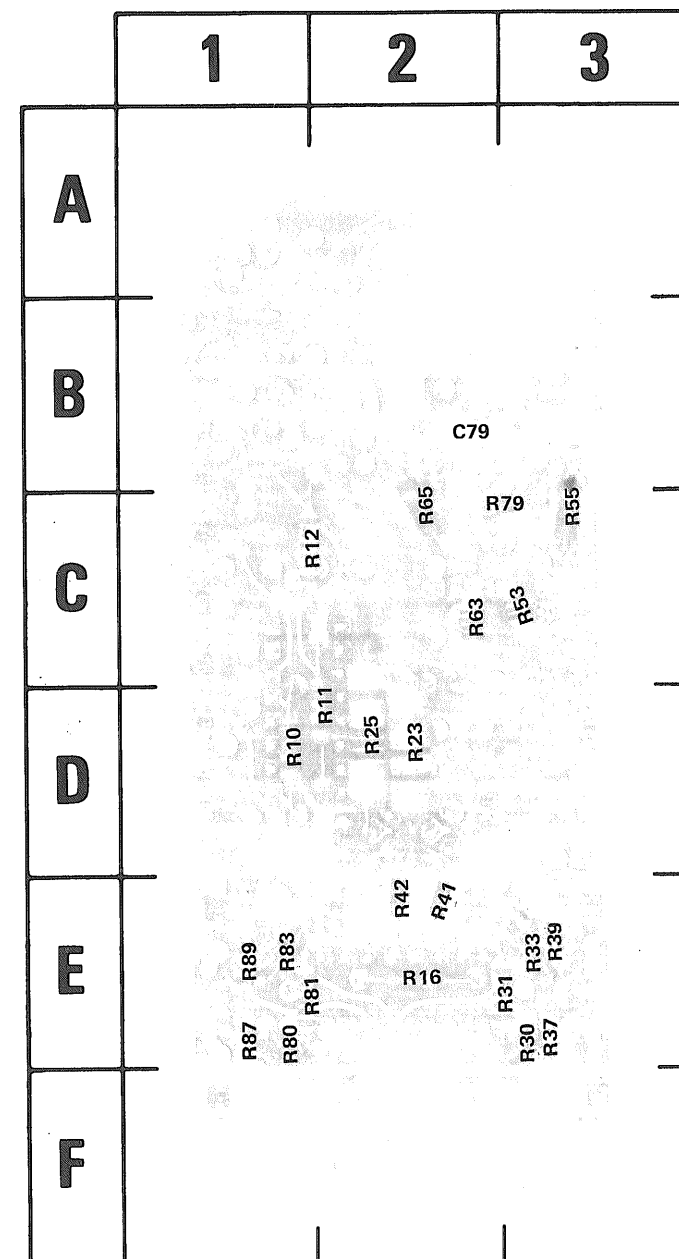
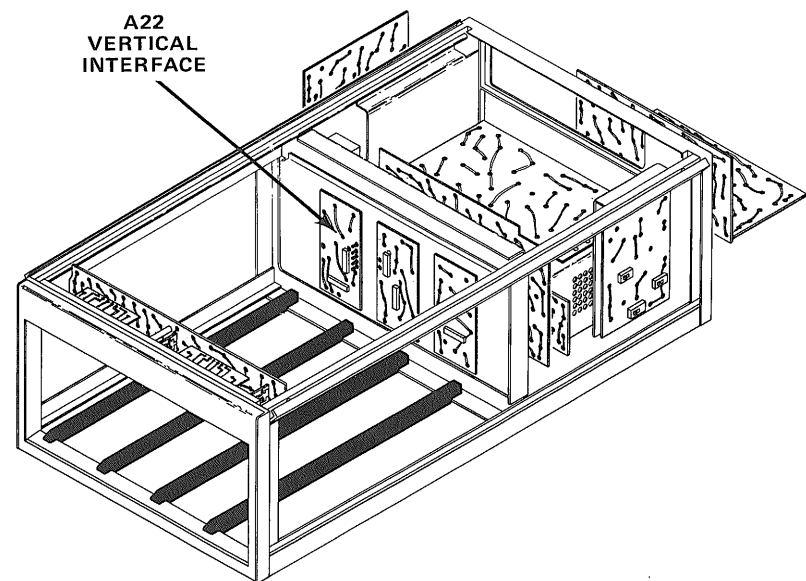

Fig. 6-10 A22 - Vertical Interface circuit board (rear view).

CKT NO	GRID LOC	CKT NO	GRID LOC	CKT NO	GRID LOC	CKT NO	GRID LOC
C79	2B	R25	2D	R42	2E	R81	1E
		R30	3E	R53	3C	R83	1E
R10	1D	R31	3E	R55	3C	R87	1E
R11	2D	R33	3E	R63	2C	R89	1E
R12	1C	R37	3E	R65	2C		
R16	2E	R39	3E	R79	3C		
R23	2D	R41	2E	R80	1E		

VOLTAGE CONDITIONS

The voltages shown on this diagram were obtained with the test set-up and equipment listed below. These measurements are not absolute and may vary slightly between instruments.

Recommended Test Equipment

Item	Specifications	Examples of Applicable Test Equipment
Dc voltmeter (non-loading digital multimeter)	Input impedance, 10 megohms; range, 0 to 20 volts dc.	a. Tektronix 7D13 Digital Multimeter (test oscilloscope must have readout system). b. Fairchild Model 7050.

Test Set-Up

7704A Under Test: No plug-in units installed.

Front-Panel Controls

Knob-type controls	Midrange
VERTICAL MODE	LEFT
A AND B TRIGGER SOURCE	VERT MODE
HORIZONTAL MODE	B

Test Equipment: Voltmeter common is connected to 7704A chassis ground.

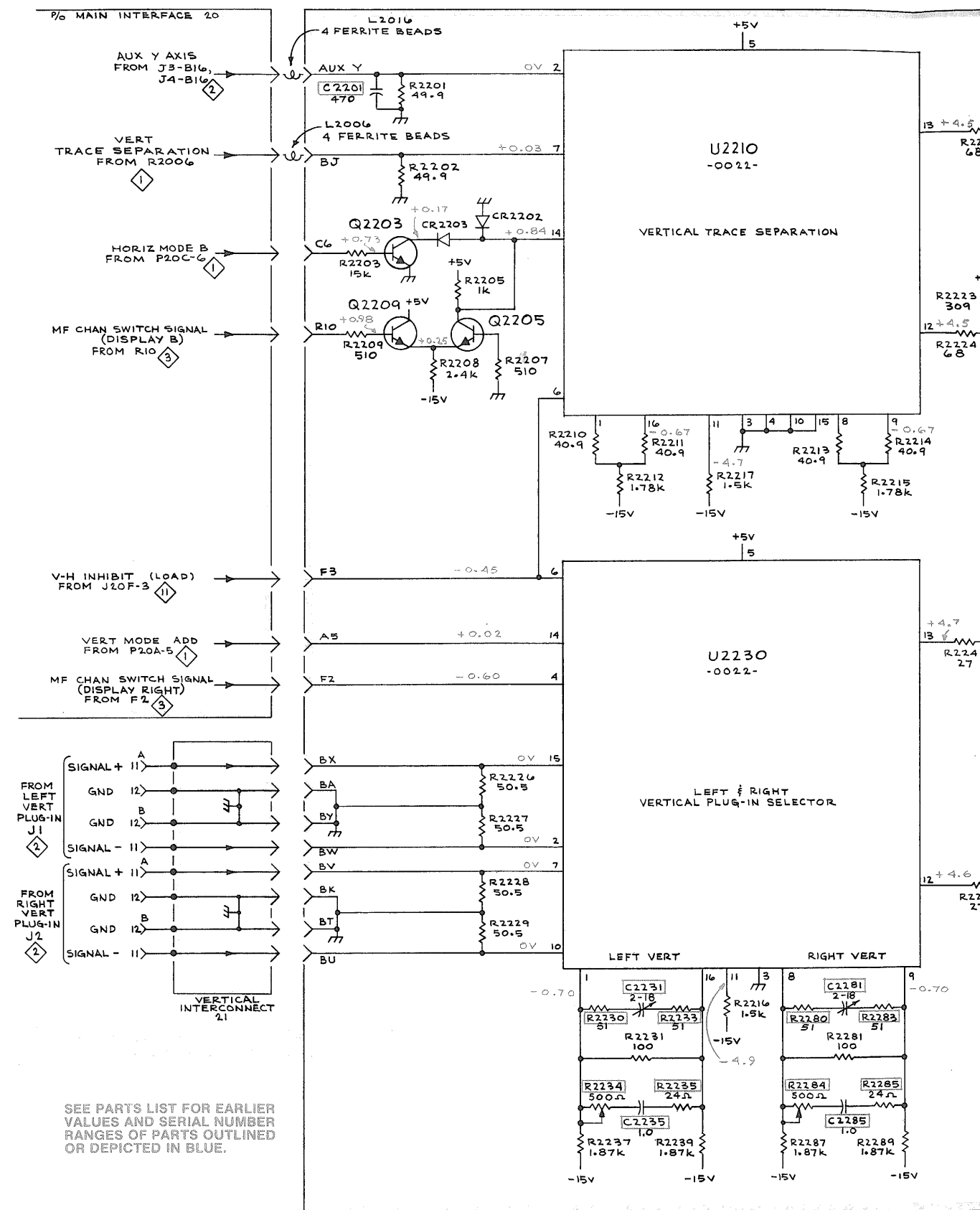

not absolute

eter (test
1).

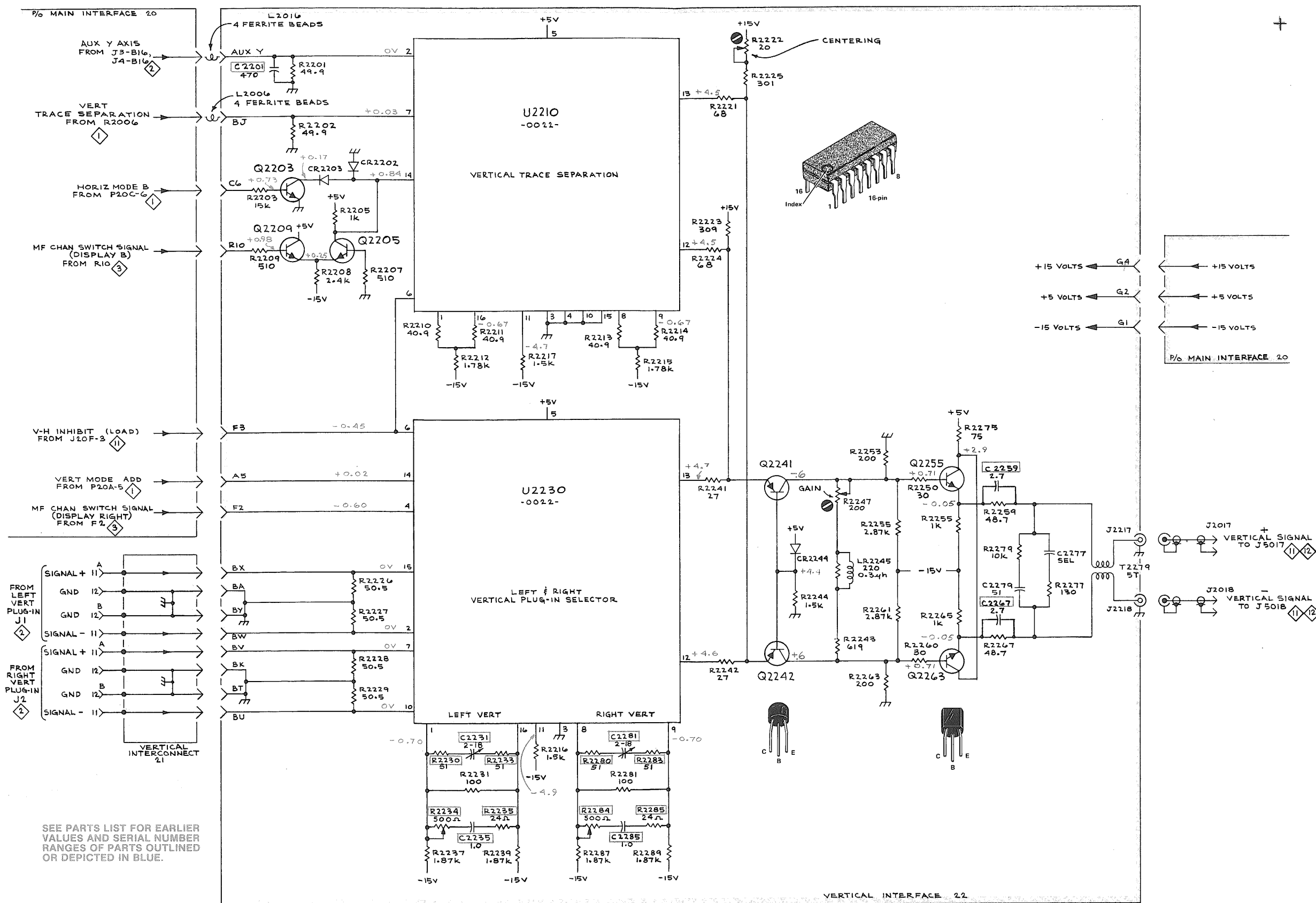

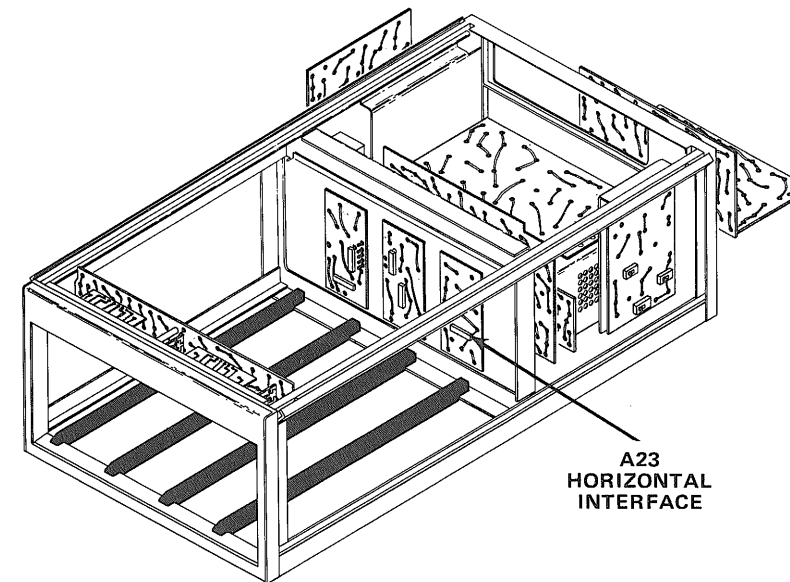
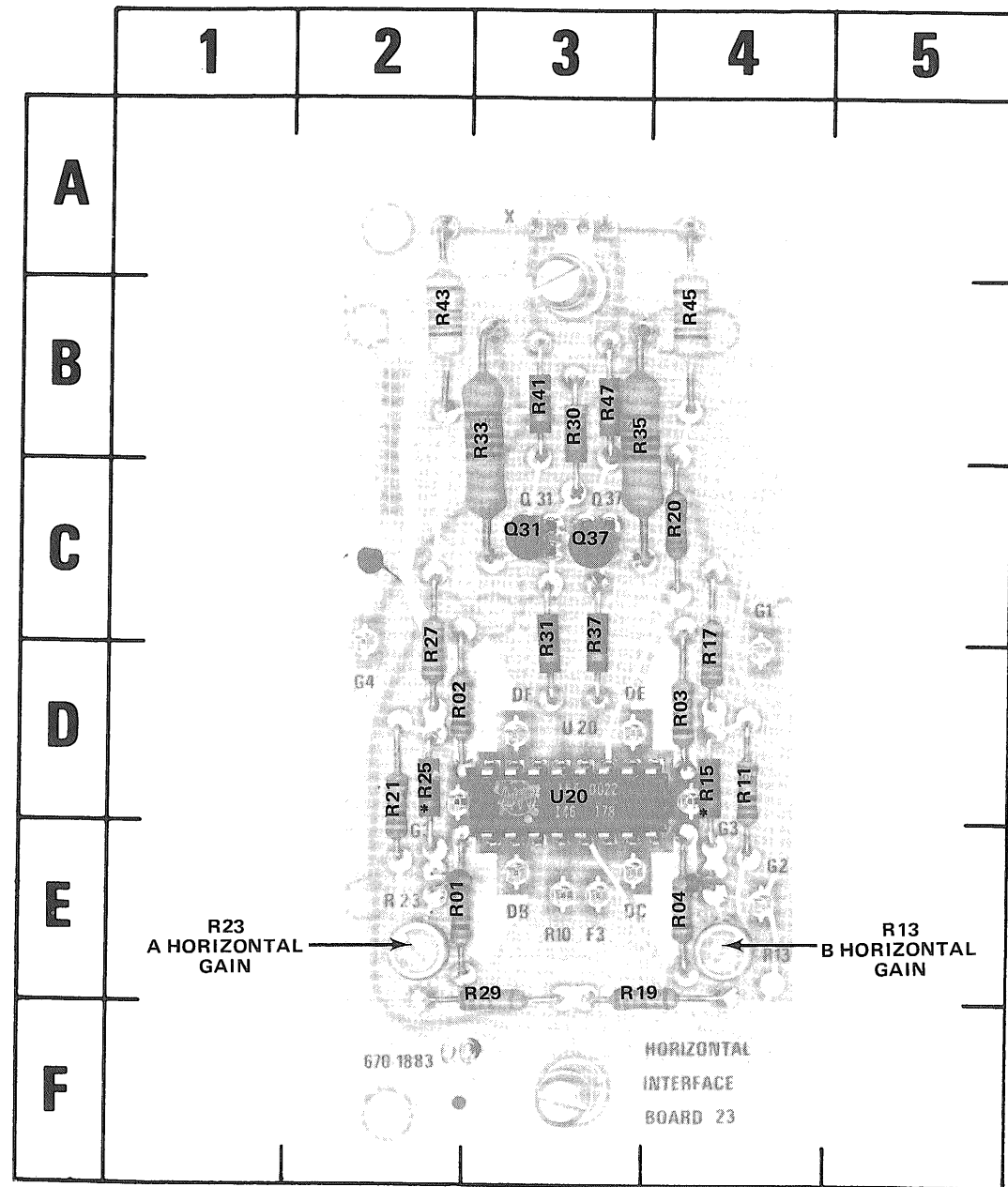

Fig. 6-11. A23 - Horizontal Interface circuit board.

*See Parts List for serial number ranges.

CKT NO	GRID LOC	CKT NO	GRID LOC	CKT NO	GRID LOC	CKT NO	GRID LOC
Q31	3C	R11	4D	R25	2D	R37	3C
Q37	3C	R13	4E	R27	2C	R41	3B
		R15	4D	R29	3E	R43	2B
R01	2E	R17	4C	R30	3B	R45	4B
R02	2D	R19	3E	R31	3C	R47	3B
R03	4D	R20	4C	R33	3B		
R04	4E	R21	2D	R35	3B	U20	3D
		R23	2E				

VOLTAGE CONDITIONS

The voltages shown on this diagram were obtained with the test set-up and equipment listed below. These measurements are not absolute and may vary slightly between instruments.

Recommended Test Equipment

Item	Specifications	Examples of Applicable Test Equipment
Dc voltmeter (non-loading digital multimeter)	Input impedance, 10 megohms; range, 0 to 20 volts dc.	a. Tektronix 7D13 Digital Multimeter (test oscilloscope must have readout system). b. Fairchild Model 7050.

Test Set-Up

7704A Under Test: No plug-in units installed.

Front-Panel Controls

Knob-type controls	Midrange
VERTICAL MODE	LEFT
A AND B TRIGGER SOURCE	VERT MODE
HORIZONTAL MODE	B

Test Equipment: Voltmeter common is connected to 7704A chassis ground.

+

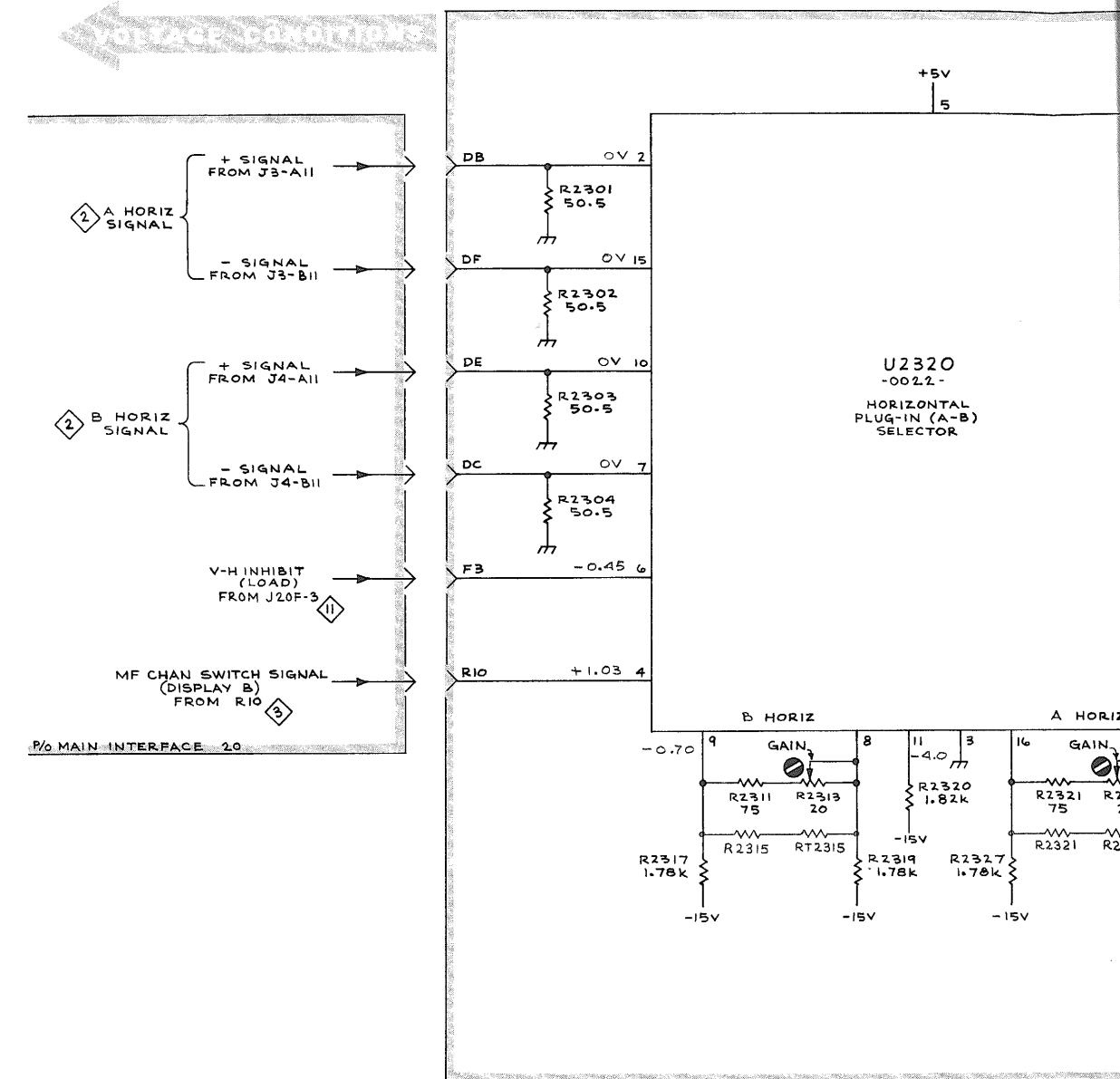

7704A (ACQUISITION UNIT)

(B)

(A)

+

not absolute

eter (test
1).

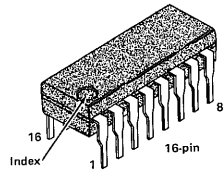
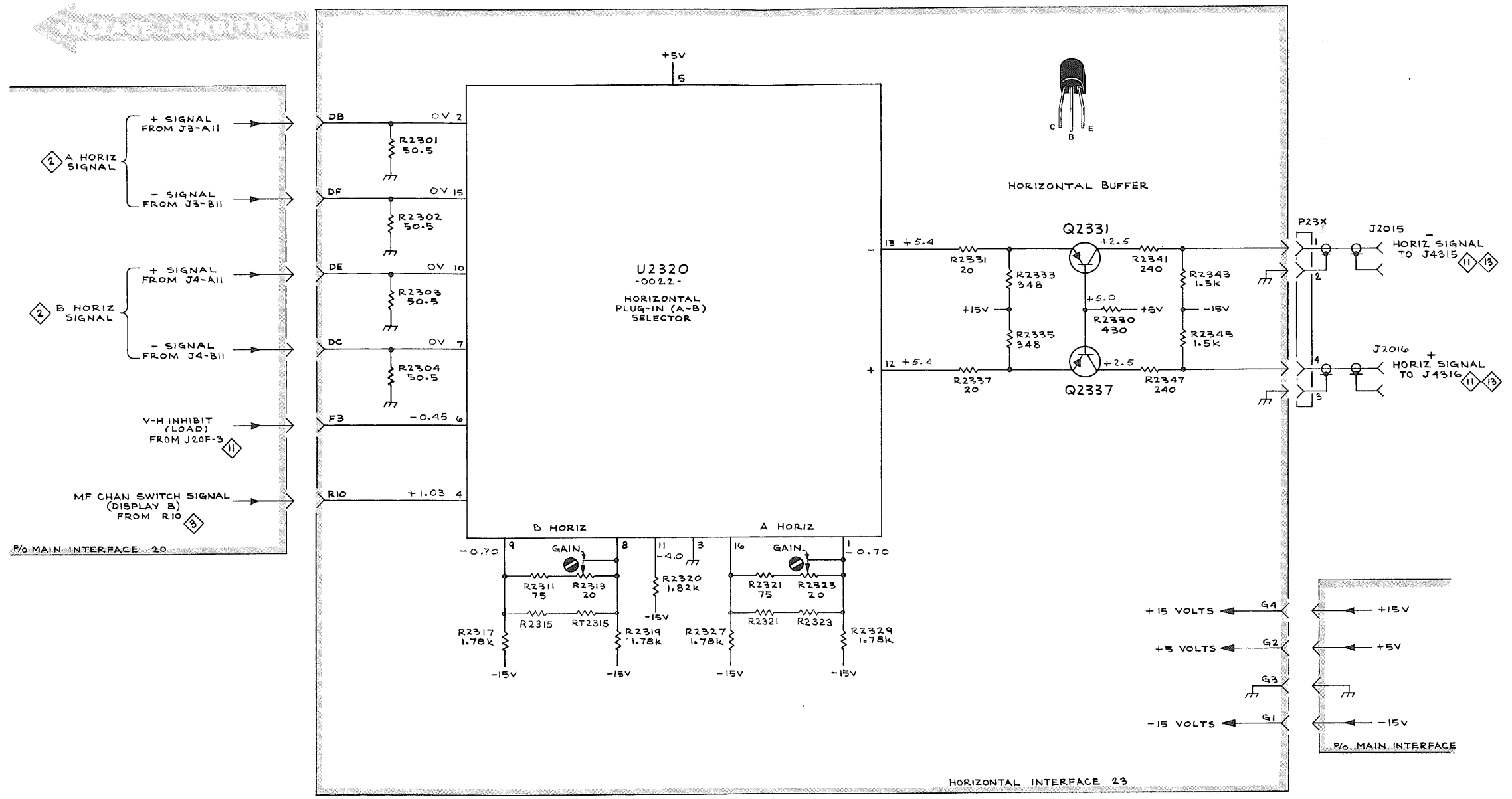

7704A (ACQUISITION UNIT)

(B)

HORIZONTAL INTERFACE (6)

REV. MAR 1974

+

(A)

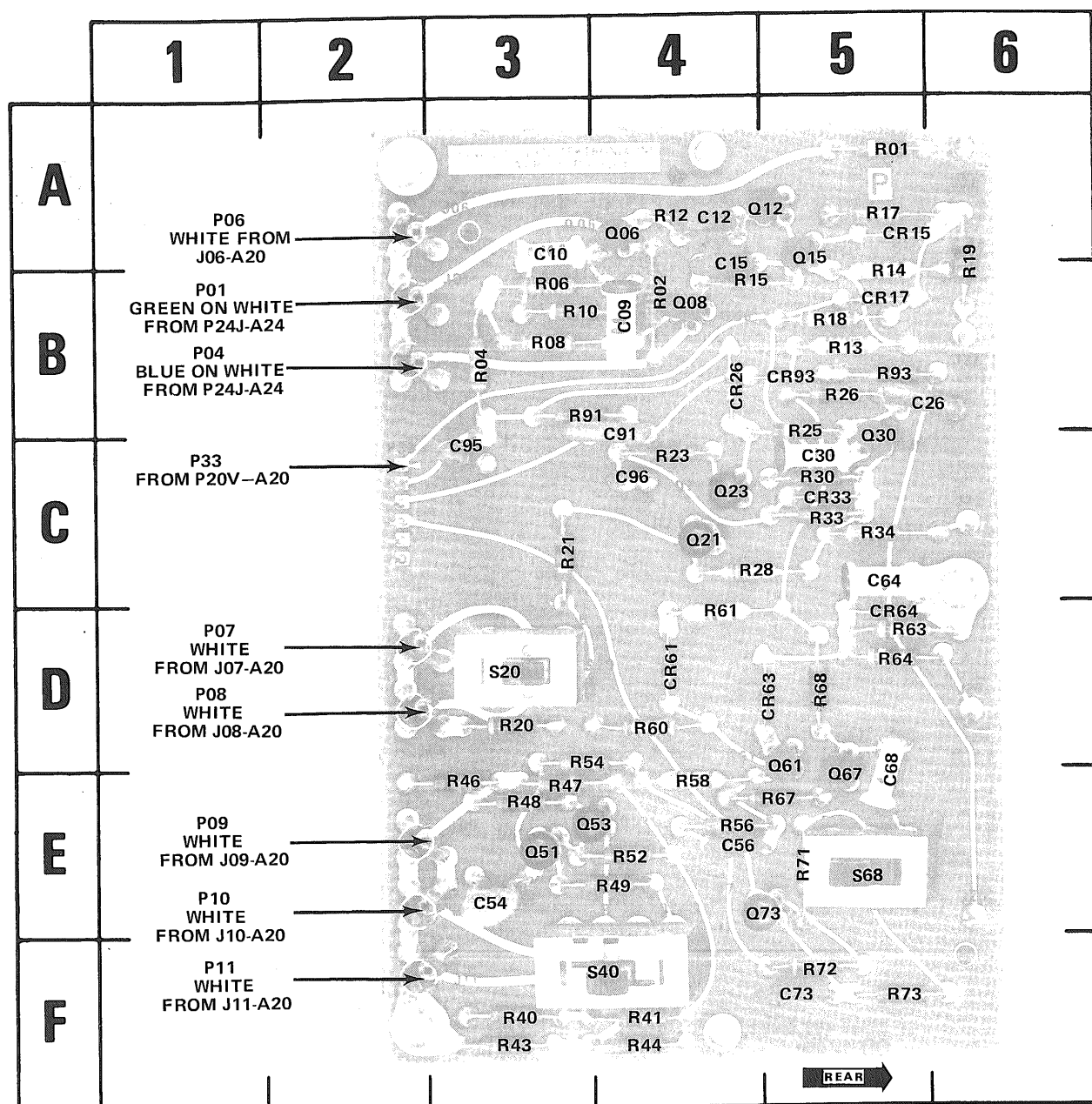
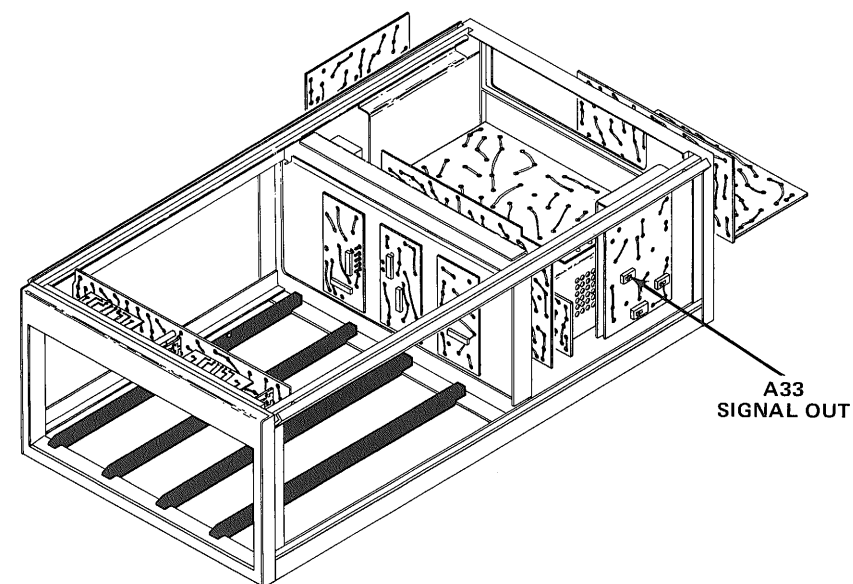

Fig. 6-12. A33 - Signal Out circuit board.



CKT NO	GRID LOC	CKT NO	GRID LOC	CKT NO	GRID LOC	CKT NO	GRID LOC	CKT NO	GRID LOC	CKT NO	GRID LOC	CKT NO	GRID LOC	CKT NO	GRID LOC
C09	4B	C95	3C	P04	2B	Q15	5A	R03	3B	R21	3C	R46	3E	R67	5E
C10	3A	C96	4C	P06	2A	Q21	4C	R06	3B	R23	4C	R47	3E	R68	5D
C12	4A			P07	2D	Q23	4C	R08	3B	R25	5B	R48	3E	R71	5E
C15	4A	CR15	5A	P08	2D	Q30	5C	R10	3B	R26	5B	R49	4E	R72	5F
C26	5B	CR17	5B	P09	2E	Q51	3E	R12	4A	R28	4C	R52	4E	R73	5F
C30	5C	CR26	4B	P10	2E	Q53	3E	R13	5B	R30	5C	R54	3D	R91	3B
C54	3E	CR33	5C	P11	2F	Q61	5E	R14	5B	R33	5C	R56	4E	R93	5B
C56	4E	CR61	4D	P33	2C	Q67	5E	R15	4B	R34	5C	R58	4E		
C64	5C	CR63	5D			Q73	5E	R17	5A	R40	3F	R60	4D	S20	3D
C68	5E	CR64	5D	Q06	4A			R18	5B	R41	4F	R61	4D	S40	4F
C73	5F	CR93	5B	Q08	4B	R01	5A	R19	5B	R43	3F	R63	5D	S68	5E
C91	4C	P01	2B	Q12	5A	R02	4B	R20	3D	R44	4F	R64	5D		

VOLTAGE AND WAVEFORM CONDITIONS

The voltages and waveforms shown on this diagram were obtained with the test set-ups and equipment listed below. These measurements are not absolute and may vary slightly between instruments.

Recommended Test Equipment

Item	Specifications	Examples of Applicable Test Equipment
Test oscilloscope	Frequency response, dc to 65 MHz; deflection factor (with 10X probe), 100 mV/division to two V/division; fastest sweep rate, 500 μ s/division.	a. Tektronix 7603 Oscilloscope with 7A13 Differential Comparator, 7B50 Time Base, and P6053A Probe, or equivalent. (7A13 Differential Comparator used to obtain dc offset). b. Use item (a) above with 7A15A Amplifier in place of 7A13.
Dc voltmeter (non-loading digital multimeter)	Input impedance, 10 megohms; range, 0 to 20 volts dc.	a. Tektronix 7D13 Digital Multimeter (test oscilloscope must have readout system), or equivalent. b. Fairchild Model 7050.

Test Set-Up

7704A Under Test: Amplifier unit installed in LEFT VERT compartment. No signal applied for voltage measurements; trace is centered. For waveforms, the 7704A Calibrator signal is applied to the amplifier unit to obtain a centered, four-division display. A time-base unit is installed in the B HORIZ compartment. The time-base is set for auto triggering at a 0.1-ms/division sweep rate.

Front-Panel Controls

Knob-type controls	Midrange
VERTICAL MODE	LEFT
A and B TRIGGER SOURCE	VERT MODE
HORIZONTAL MODE	B

Internal Controls (on A33-Signal Output board)

Sweep Selector	B
Gate Selector	B
Readout Mode	Free-Run

Test Equipment: Voltmeter common is connected to 7704A chassis ground. Test oscilloscope is externally triggered from 7704A +GATE OUT connector.

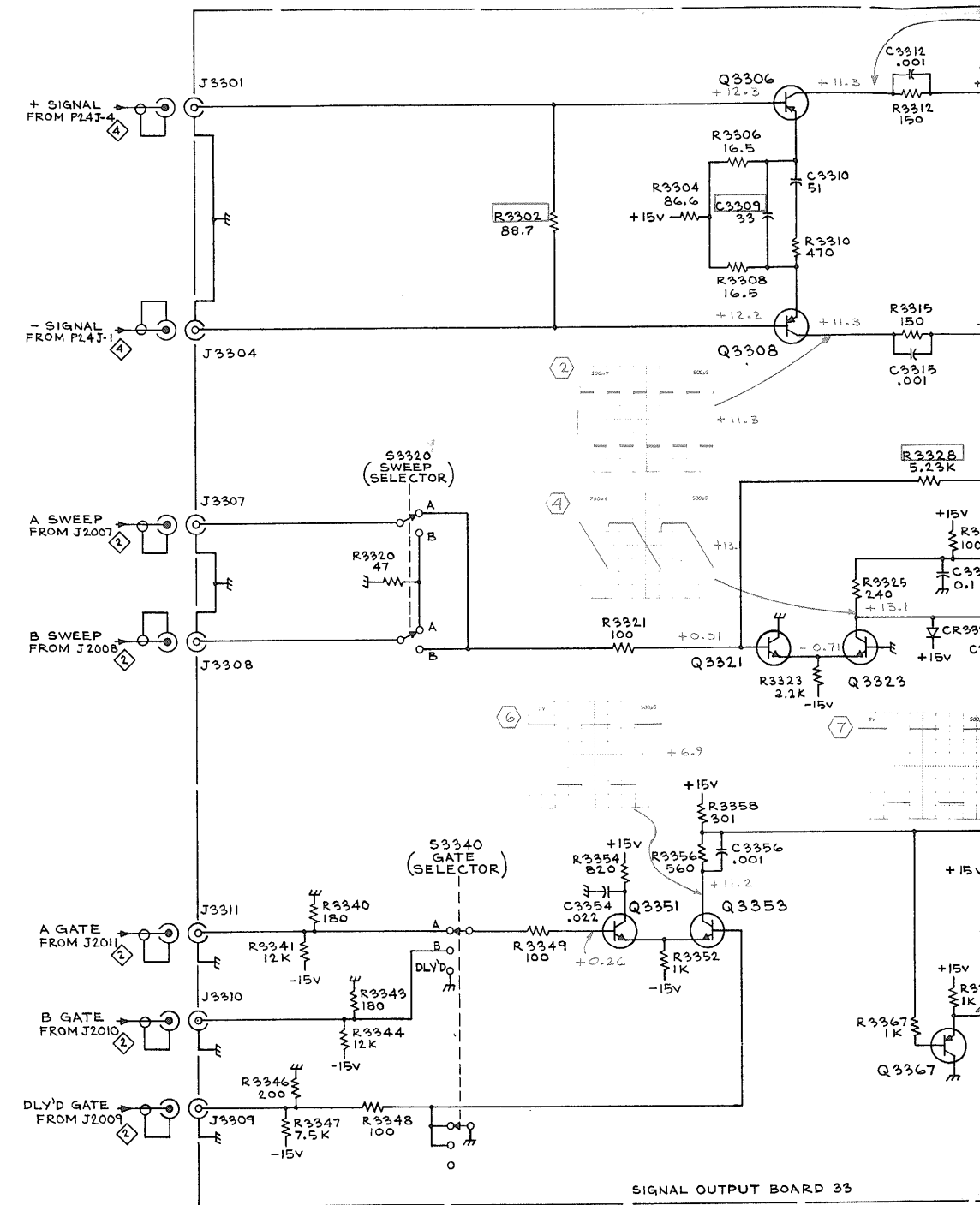

SEE PARTS LIST FOR EARLIER VALUES AND SERIAL NUMBER RANGES OF PARTS OUTLINED OR DEPICTED IN BLUE.



Measurements are

with 7A13
base, and
3 Differential
offset).

Amplifier in

center (test
stem), or

centered. For
it is installed

+GATE OUT

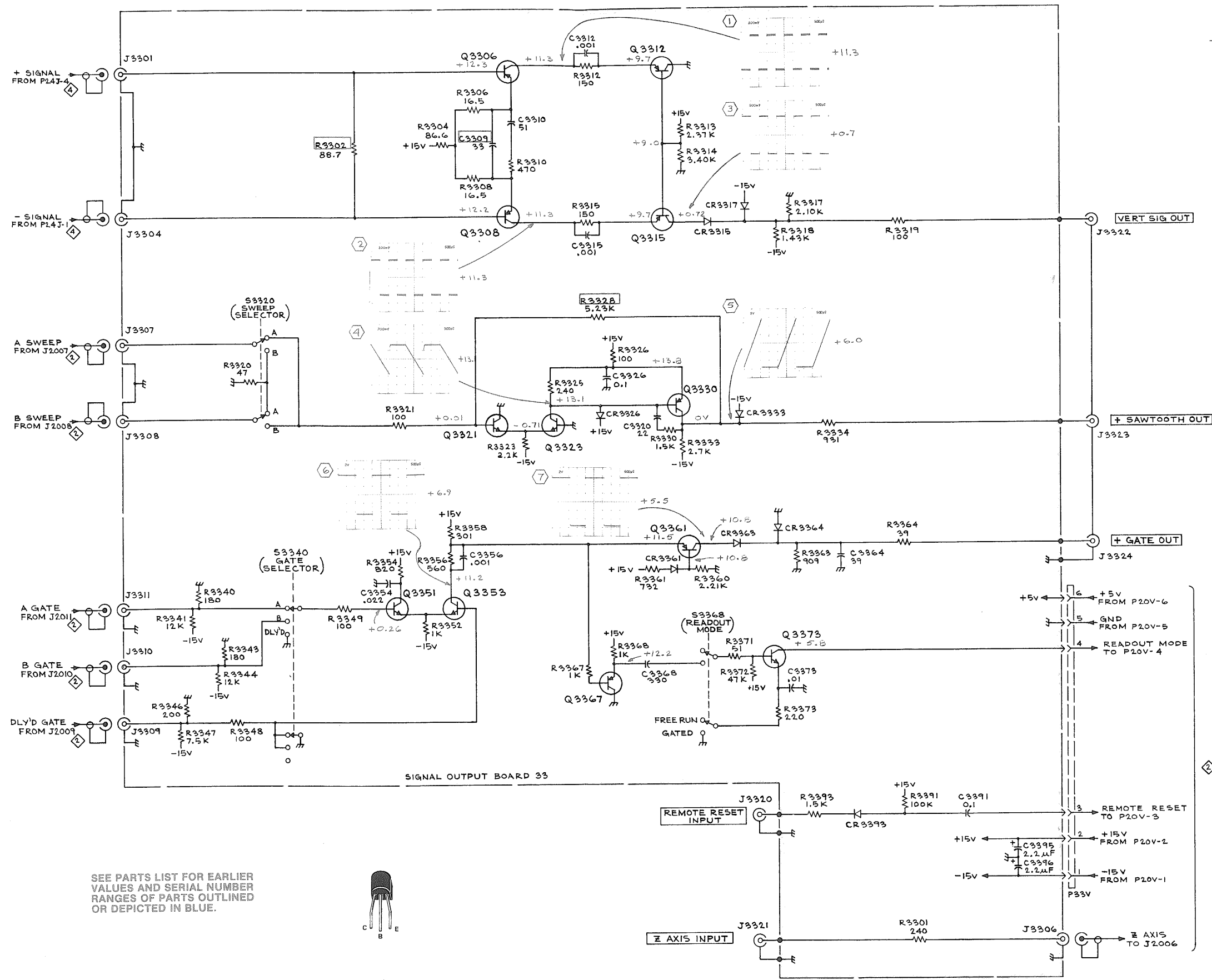

SEE PARTS LIST FOR EARLIER
VALUES AND SERIAL NUMBER
RANGES OF PARTS OUTLINED
OR DEPICTED IN BLUE.

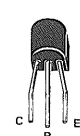

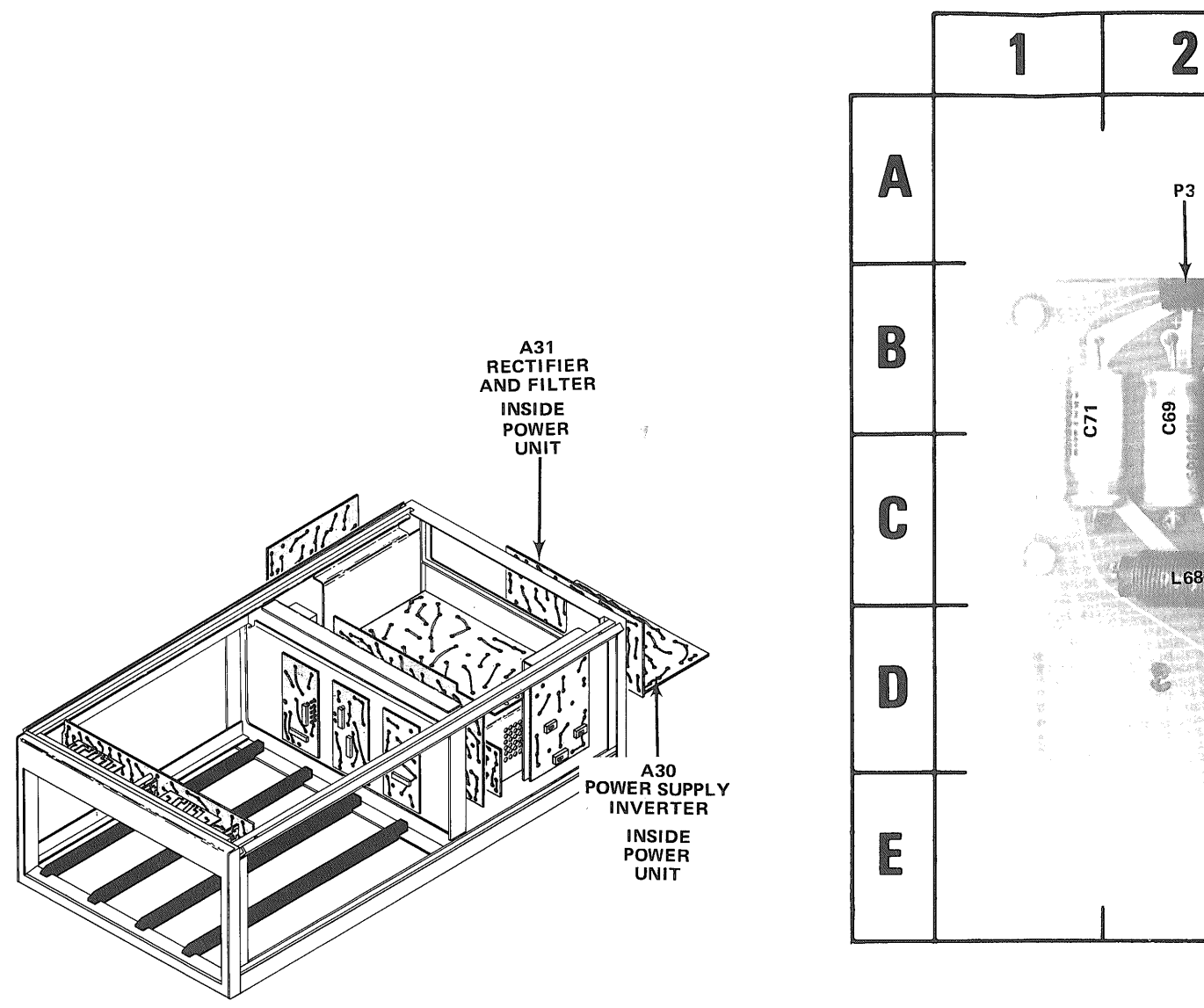
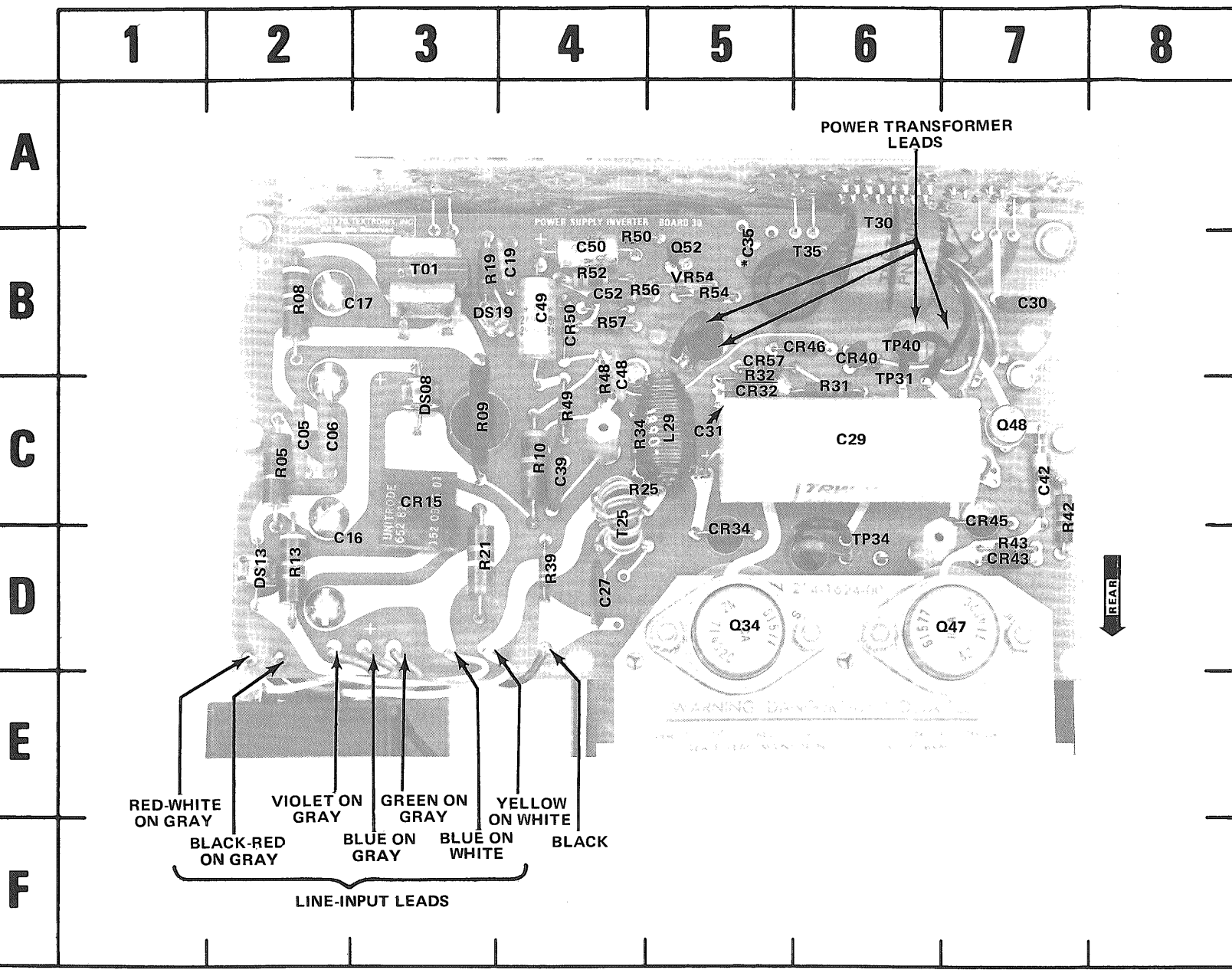

*See Parts List for serial number ranges.

Fig. 6-13. A30 - Power Supply Inverter circuit board.

CKT NO	GRID LOC	CKT NO	GRID LOC	CKT NO	GRID LOC	CKT NO	GRID LOC	CKT NO	GRID LOC	CKT NO	GRID LOC	CKT NO	GRID LOC	CKT NO	GRID LOC
C05	2C	C42	7C	CR43	6B	Q34	5D	R19	3B	R43	7D	T01	3B	VR54	5B
C06	2C	C48	4B	CR45	7C	Q47	7D	R21	3D	R48	4C	T25	4C		
C16	2D	C49	4B	CR46	6B	Q48	7C	R25	4C	R49	4C	T30	6A		
C17	3B	C50	4B	CR50	4B	Q52	5B	R31	6C	R50	4B	T35	6B		
C19	4B	C52	4B	CR57	5B			R32	5B	R52	4B				
C27	4D			DS08	3C	R05	2C	R34	4C	R54	5B	TP31	6B		
C29	6C	CR15	3C	DS13	2D	R08	2B	R39	4D	R56	4B	TP34	6D		
C30	7B	CR32	5C	DS19	3B	R09	3C	R42	7C	R57	4B	TP40	6B		
C31	5C	CR34	5D			R10	3C								
C35	5B	CR40	6B	L29	5C	R13	2D								
C39	4C														

CKT NO	GRID LOC	CKT NO
C05	8D	C54
C06	6D	C68
C08	6D	C69
C13	7D	C70
C14	6D	C71
C17	6D	C72
C25	6D	C73
C26	6C	C74
C27	4D	C75
C29	4D	C78
C34	6C	C79
C43	6C	C81
C50	6D	C82
C53	5D	

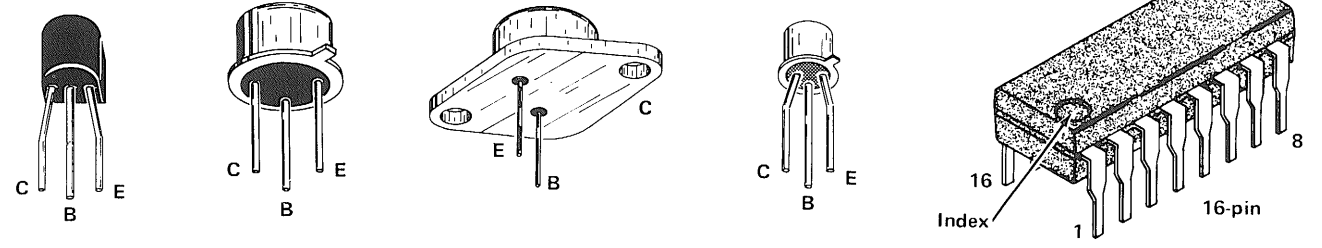

Fig. 6-15. Electrode configuration for semiconductors shown on diagram 8.

REV. MAR 1974

REV. C, NOV. 1974

8

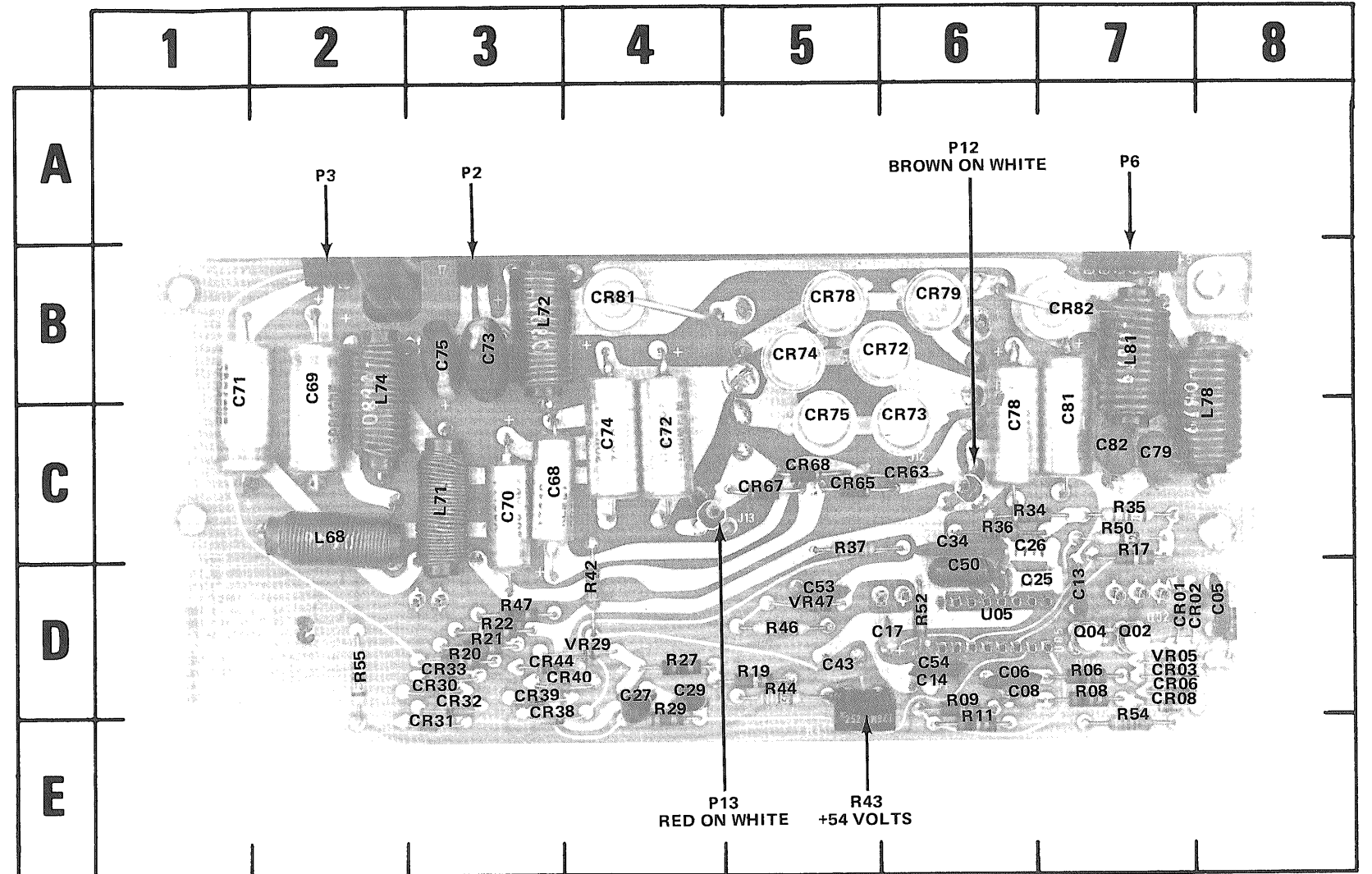
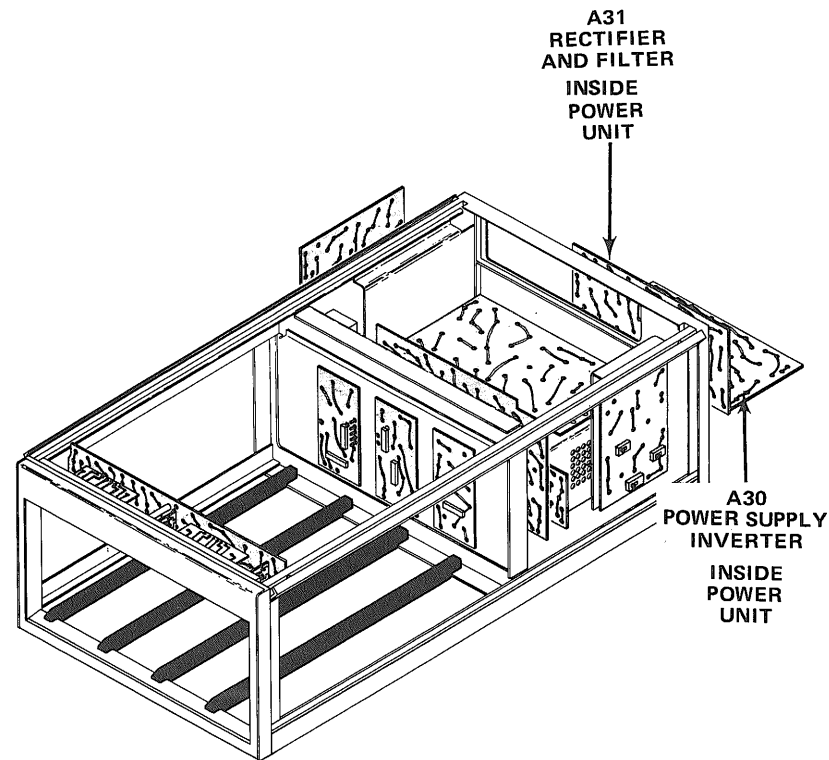

Fig. 6-14. A31 - Rectifier and Filter circuit board.

CKT NO	GRID LOC	CKT NO	GRID LOC	CKT NO	GRID LOC	CKT NO	GRID LOC	CKT NO	GRID LOC	CKT NO	GRID LOC	CKT NO	GRID LOC	CKT NO	GRID LOC
C05	8D	C54	6D	CR01	7D	CR63	6C	L68	2C	Q02	7D	R22	3D	R52	6D
C06	6D	C68	3C	CR02	8D	CR65	6C	L71	3C	Q04	7D	R29	4D	R54	7D
C08	6D	C69	2B	CR03	7D	CR67	5C	L72	3B	R05	8D	R34	6C	R55	2D
C13	7D	C70	3C	CR06	7D	CR68	5C	L74	2B	R06	7D	R35	7C	R77	4D
C14	6D	C71	1B	CR08	7D	CR72	6B	L78	8B	R08	7D	R36	6C		
C17	6D	C72	4C	CR30	3D	CR73	6C	L81	7B	R09	6D	R37	5C	U05	6D
C25	6D	C73	3B	CR31	3D	CR74	5B			R11	6D	R42	4D		
C26	6C	C74	4C	CR32	3D	CR75	5C	P2	3B	R17	7C	R43	5D	VR05	7D
C27	4D	C75	3B	CR33	3D	CR78	5B	P3	2B	R19	5D	R44	5D	VR29	4D
C29	4D	C78	6C	CR38	3D	CR79	6B	P6	7B	R20	3D	R46	5D	VR47	5D
C34	6C	C79	7C	CR39	3D	CR81	4B	P12	6C	R21	3D	R47	3D		
C43	6C	C81	7C	CR40	4D	CR82	7B	P13	4C	R50	7C				
C50	6D	C82	7C	CR44	3D										
C53	5D														

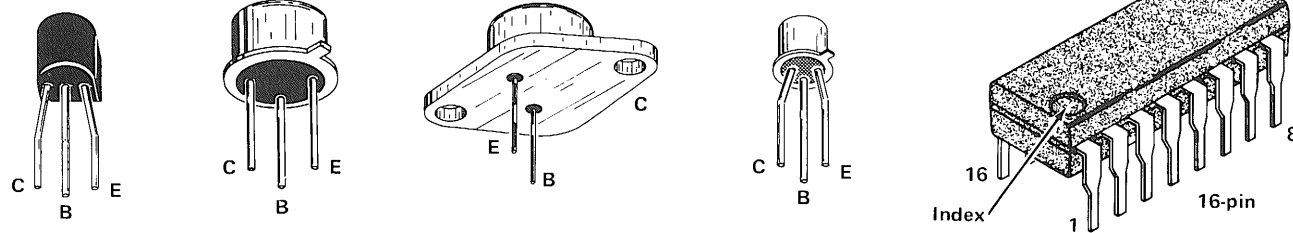

Fig. 6-15. Electrode configuration for semiconductors shown on diagram 8.

REV. MAR 1974

REV. B, NOV. 1974

VOLTAGE AND WAVEFORM CONDITIONS

The voltages and waveforms shown on this diagram were obtained with the test set-ups and equipment given below. These measurements are not absolute and may vary between instruments.

Recommended Test Equipment

Item	Specifications	Examples of Applicable Test Equipment
Test oscilloscope	Frequency response, dc to 65 MHz; deflection factor (with 10X probe), 500 mV/division to five or 10 V/division; fastest sweep rate, 500 ns/division.	a. Tektronix 7603 Oscilloscope with 7A15A Amplifier or 7A13 Differential Comparator, 7B50 Time Base, and P6053A Probe, or equivalent.
Dc voltmeter (non-loading digital multimeter)	Input impedance, 10 megohm; range, 0 to 500 volts dc.	a. Tektronix 7D13 Digital Multimeter (test oscilloscope must have readout system), or equivalent. b. Fairchild Model 7050.

Test Set-Up

7704A Under Test: Amplifier unit installed in LEFT VERT Compartment; no signal applied. Time-base unit installed in B HORIZ compartment. Time-base unit set for free-running sweep at 0.1-ms/division sweep rate. Line voltage source of 115 volts ac. Line Selector set for 90 to 132.

Front-Panel Controls

Knob-type controls	Midrange
VERTICAL MODE	LEFT
A AND B TRIGGER SOURCE	VERT MODE
HORIZONTAL MODE	B

Test Equipment: Voltmeter common is connected to 7704A chassis ground except for voltages marked *; for *, voltmeter is connected between the two points. Test Oscilloscope is internally triggered.

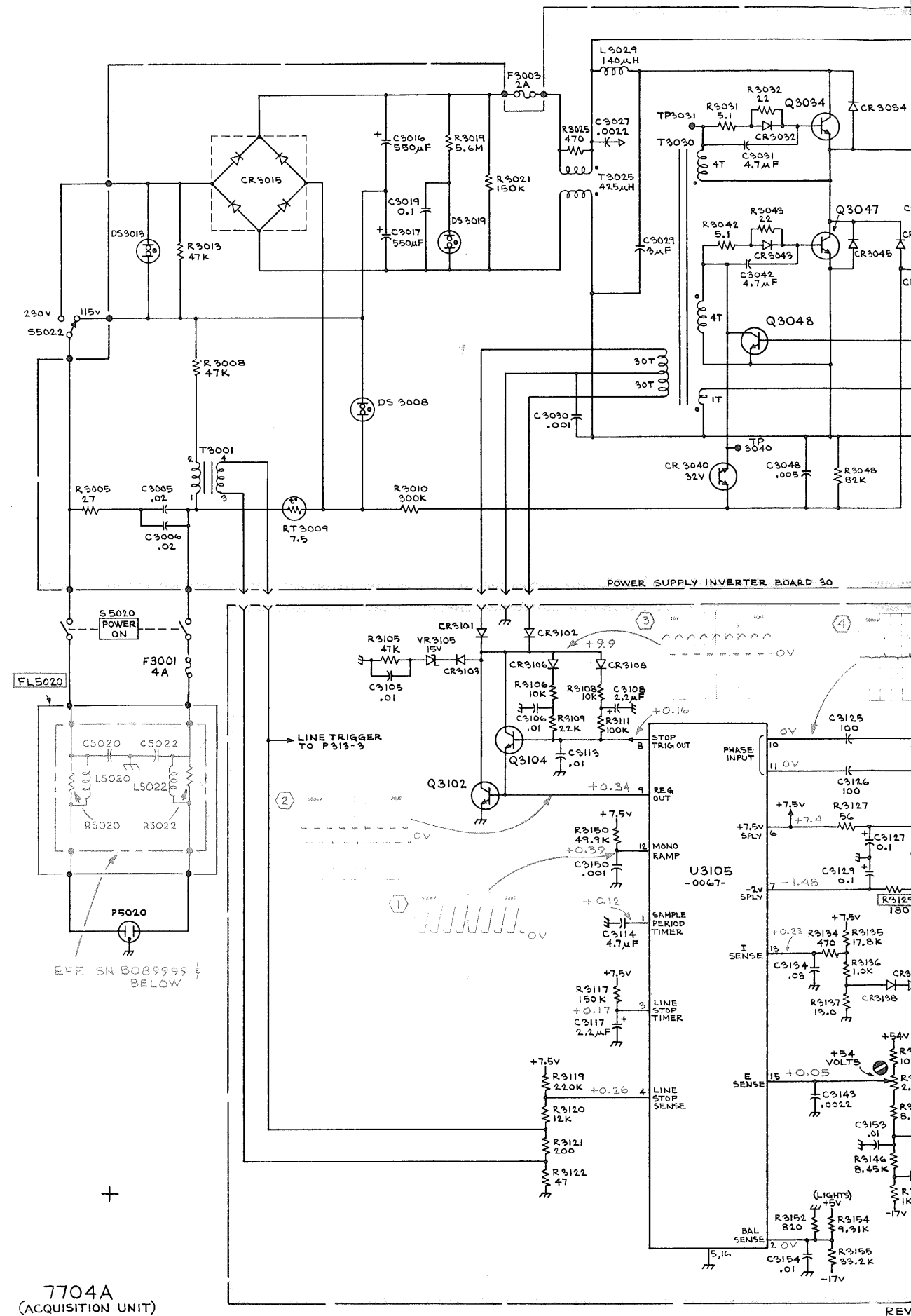

lements are

7A15A
varator,
be, or

r (test
m), or

B HORIZ
tor set for

connected

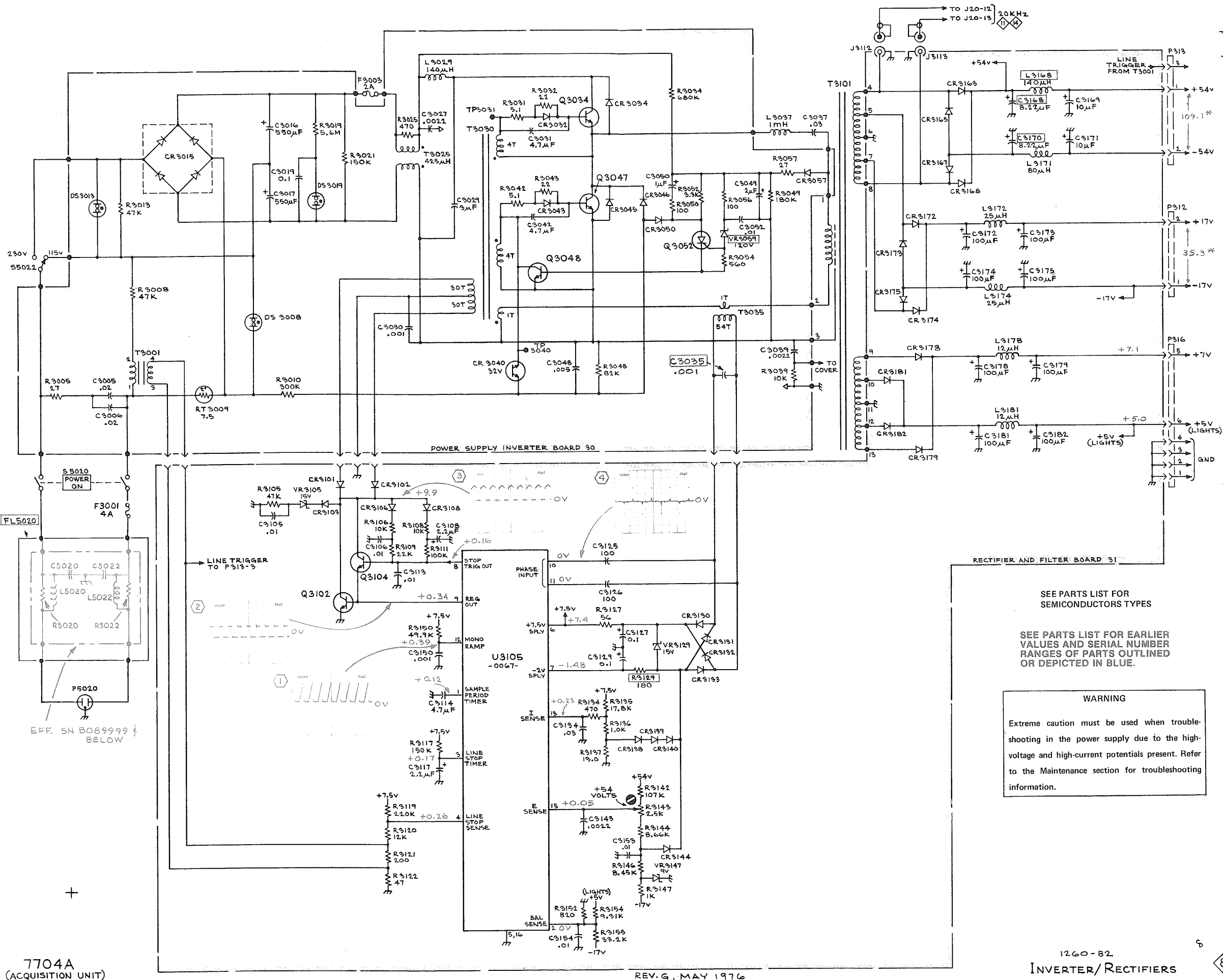

7704A
(ACQUISITION UNIT)

REV. G, MAY 1976

SEE PARTS LIST FOR SEMICONDUCTORS TYPES

SEE PARTS LIST FOR EARLIER VALUES AND SERIAL NUMBER RANGES OF PARTS OUTLINED OR DEPICTED IN BLUE.

WARNING

Extreme caution must be used when troubleshooting in the power supply due to the high-voltage and high-current potentials present. Refer to the Maintenance section for troubleshooting information.

1260-82
INVERTER/RECTIFIERS

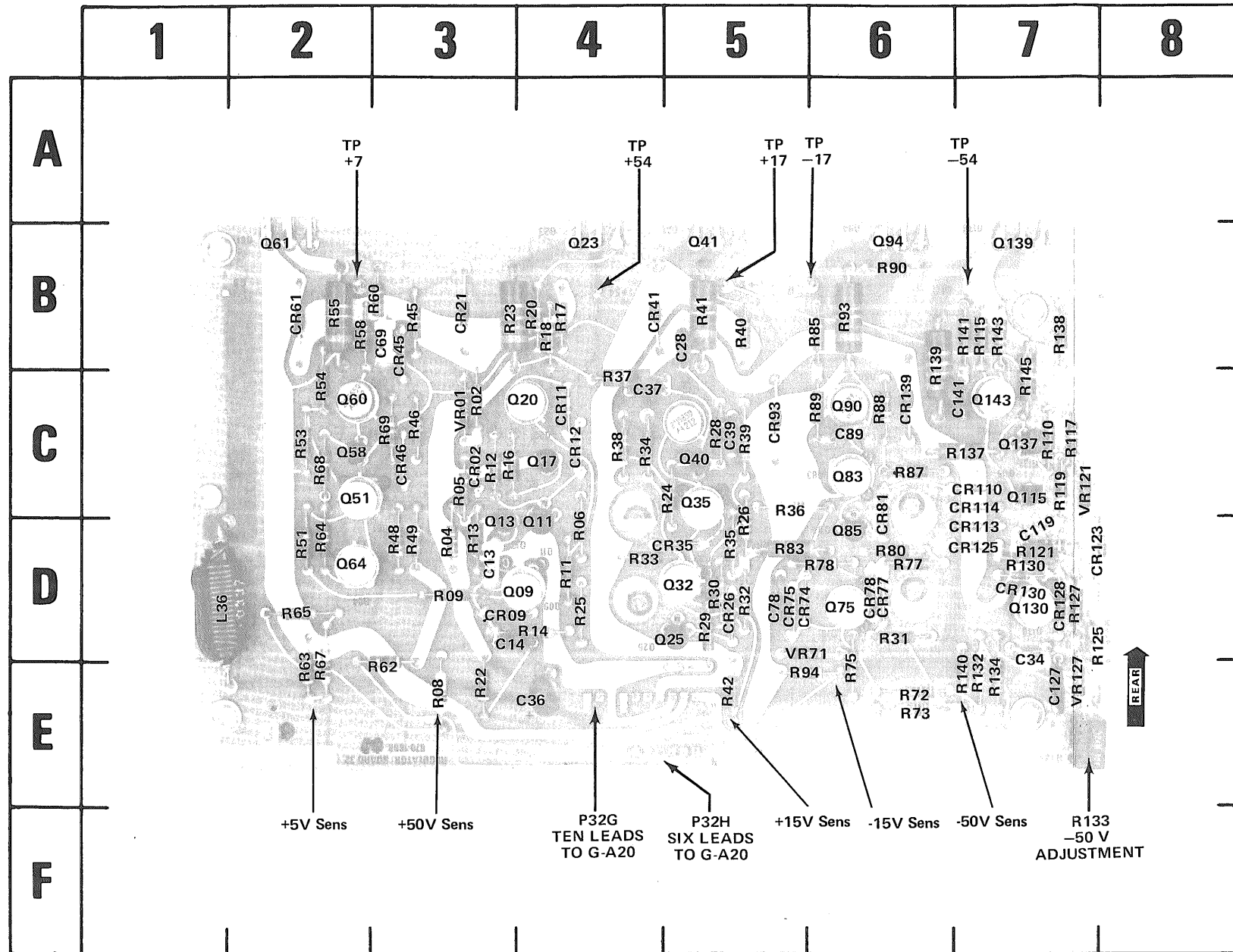
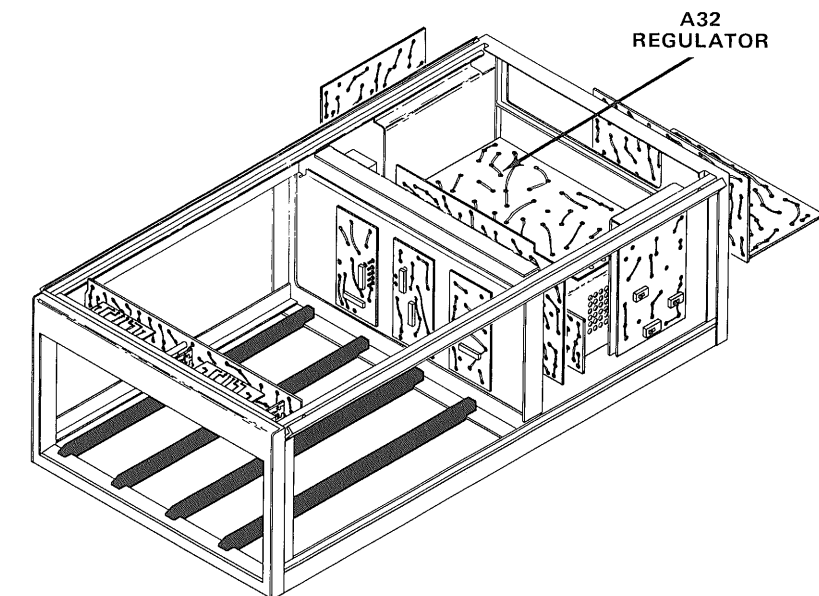
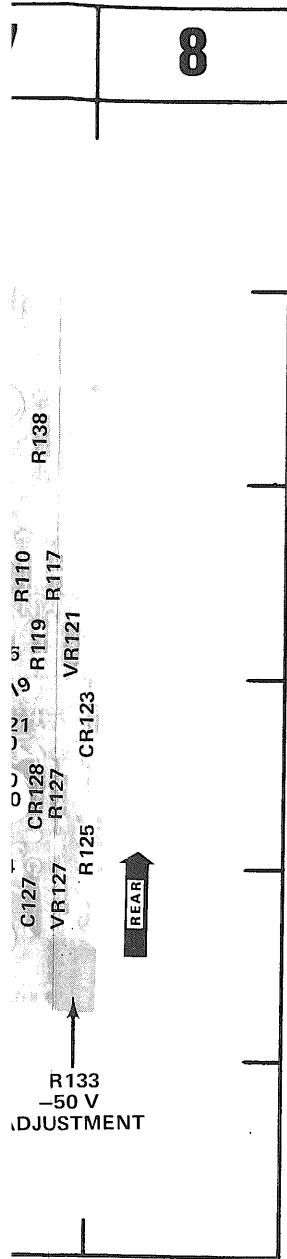

Fig. 6-16. A32-Regulator circuit board.



CKT NO	GRID LOC	CKT NO	GRID LOC	CKT NO	GRID LOC	CKT NO	GRID LOC	CKT NO	GRID LOC	CKT NO	GRID LOC	CKT NO	GRID LOC	CKT NO	GRID LOC
C13	3D	CR61	2B	Q09	4D	Q94	6B	R20	4B	R45	3B	R77	6D	R133	7E
C14	3D	CR74	5D	Q11	4D	Q115	7C	R22	3E	R46	3C	R78	6D	R134	7E
C28	5B	CR75	5D	Q13	3D	Q130	7D	R23	3B	R48	3D	R80	6D	R137	7C
C34	7D	CR77	6D	Q17	4C	Q137	7C	R24	5C	R49	3D	R83	5D	R138	7B
C36	4E	CR78	6D	Q20	4C	Q139	7B	R25	4D	R51	2D	R85	6B	R139	6C
C37	4C	CR81	6C	Q23	4B	Q143	7C	R26	5D	R53	2C	R87	6C	R140	7E
C39	5C	CR93	5C	Q25	5D			R28	5C	R54	2C	R88	6C	R141	7B
C69	3B	CR110	7C	Q32	5D	R02	3C	R29	5D	R55	2B	R89	6C	R143	7B
C78	5D	CR113	7D	Q35	5C	R04	3D	R30	5D	R58	2B	R90	6B	R145	7C
C89	6D	CR114	7C	Q40	5C	R05	3C	R31	6D	R60	3B	R93	6B		
C119	7D	CR123	7D	Q41	5B	R06	4D	R32	6D	R62	3E	R94	5E	TP +7	2B
C127	7D	CR125	7D	Q51	2C	R08	3E	R34	4C	R63	2E	R110	7C	TP +17	5B
C141	7C	CR128	7D	Q58	7C	R09	3D	R35	5D	R64	2D	R115	7B	TP -17	6B
		CR130	7D	Q60	2C	R11	4D	R36	5C	R65	2D	R117	7C	TP +54	4B
		CR139	6C	Q61	2B	R12	3C	R37	4C	R67	2E	R119	7C	TP -54	7B
CR02	3C			Q64	2D	R13	3D	R38	4C	R68	2C	R121	7D		
CR09	3D	L36	1D	Q75	6D	R14	4D	R39	5C	R69	3C	R125	7D	VR01	3C
CR11	4C			Q83	6C	R16	3C	R40	5B	R72	6E	R127	7D	VR71	5D
CR12	4C			Q85	6D	R17	4B	R41	5B	R73	6E	R130	7D	VR121	7C
CR21	3B	P32G	4E	Q90	6C	R18	4B	R42	5E	R75	6E	R132	7E	VR127	7E
CR26	5D	P32H	5E												
CR35	5D														
CR41	4B														
CR45	3B														
CR46	3C														





CKT NO	GRID LOC	CKT NO	GRID LOC	CKT NO	GRID LOC	CKT NO	GRID LOC	CKT NO	GRID LOC	CKT NO	GRID LOC	CKT NO	GRID LOC	CKT NO	GRID LOC
C13	3D	CR61	2B	Q09	4D	Q94	6B	R20	4B	R45	3B	R77	6D	R133	7E
C14	3D	CR74	5D	Q11	4D	Q115	7C	R22	3E	R46	3C	R78	6D	R134	7E
C28	5B	CR75	5D	Q13	3D	Q130	7D	R23	3B	R48	3D	R80	6D	R137	7C
C34	7D	CR77	6D	Q17	4C	Q137	7C	R24	5C	R49	3D	R83	5D	R138	7B
C36	4E	CR78	6D	Q20	4C	Q139	7B	R25	4D	R51	2D	R85	6B	R139	6C
C37	4C	CR81	6C	Q23	4B	Q143	7C	R26	5D	R53	2C	R87	6C	R140	7E
C39	5C	CR93	5C	Q25	5D			R28	5C	R54	2C	R88	6C	R141	7B
C69	3B	CR110	7C	Q32	5D	R02	3C	R29	5D	R55	2B	R89	6C	R143	7B
C78	5D	CR113	7D	Q35	5C	R04	3D	R30	5D	R58	2B	R90	6B	R145	7C
C89	6D	CR114	7C	Q40	5C	R05	3C	R31	6D	R60	3B	R93	6B		
C119	7D	CR123	7D	Q41	5B	R06	4D	R32	6D	R62	3E	R94	5E	TP +7	2B
C127	7D	CR125	7D	Q51	2C	R08	3E	R34	4C	R63	2E	R110	7C	TP +17	5B
C141	7C	CR128	7D	Q58	7C	R09	3D	R35	5D	R64	2D	R115	7B	TP -17	6B
		CR130	7D	Q60	2C	R11	4D	R36	5C	R65	2D	R117	7C	TP +54	4B
CR02	3C	CR139	6C	Q61	2B	R12	3C	R37	4C	R67	2E	R119	7C	TP -54	7B
CR09	3D			Q64	2D	R13	3D	R38	4C	R68	2C	R121	7D		
CR11	4C	L36	1D	Q75	6D	R14	4D	R39	5C	R69	3C	R125	7D	VR01	3C
CR12	4C			Q83	6C	R16	3C	R40	5B	R72	6E	R127	7D	VR71	5D
CR21	3B	P32G	4E	Q85	6D	R17	4B	R41	5B	R73	6E	R130	7D	VR121	7C
CR26	5D	P32H	5E	Q90	6C	R18	4B	R42	5E	R75	6E	R132	7E	VR127	7E
CR35	5D														
CR41	4B														
CR45	3B														
CR46	3C														

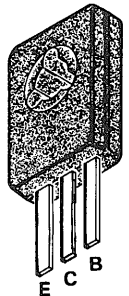
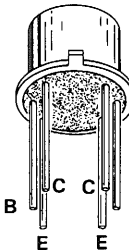
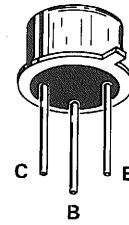
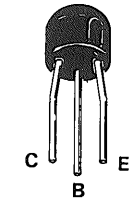
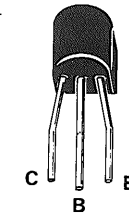
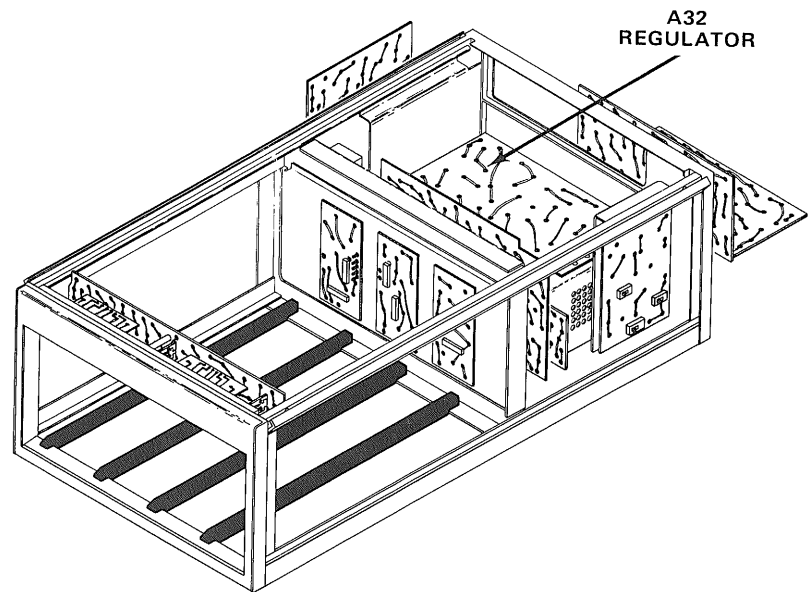

Fig. 6-17. Electrode configuration for semiconductors shown on diagram 9.

VOLTAGE AND WAVEFORM CONDITIONS

The voltages and waveforms shown on this diagram were obtained with the test set-ups and equipment listed below. These measurements are not absolute and may vary slightly between instruments.

Recommended Test Equipment

Item	Specifications	Examples of Applicable Test Equipment
Test oscilloscope	Frequency response, one Hz to 30 kHz; deflection factor (with 10X probe), one mV/division; sweep rate, five ms/division.	a. Tektronix 7603 Oscilloscope with 7A22 Differential Amplifier, 7B50 Time Base, and P6053A Probe, or equivalent.
Dc voltmeter (non-loading digital voltmeter)	Input impedance, 10 megohms; range, 0 to 100 volts dc.	a. Tektronix 7D13 Digital Multimeter (test oscilloscope must have readout system), or equivalent. b. Fairchild Model 7050.

Test Set-Up

7704A Under Test: Amplifier unit installed in LEFT VERT compartment; no signal applied. Time-base unit installed in B HORIZ compartment. Time-base unit set for free-running sweep at 0.1-ms/division sweep rate. Line-voltage source of 115 volts ac. Line Selector set for 90 to 132.

Front-Panel Controls

Knob-type controls	Midrange
VERTICAL MODE	LEFT
A AND B TRIGGER SOURCE	VERT MODE
HORIZONTAL MODE	B

Test Equipment: Voltmeter common is connected to 7704A chassis ground. Test oscilloscope is triggered from the internal Line source.

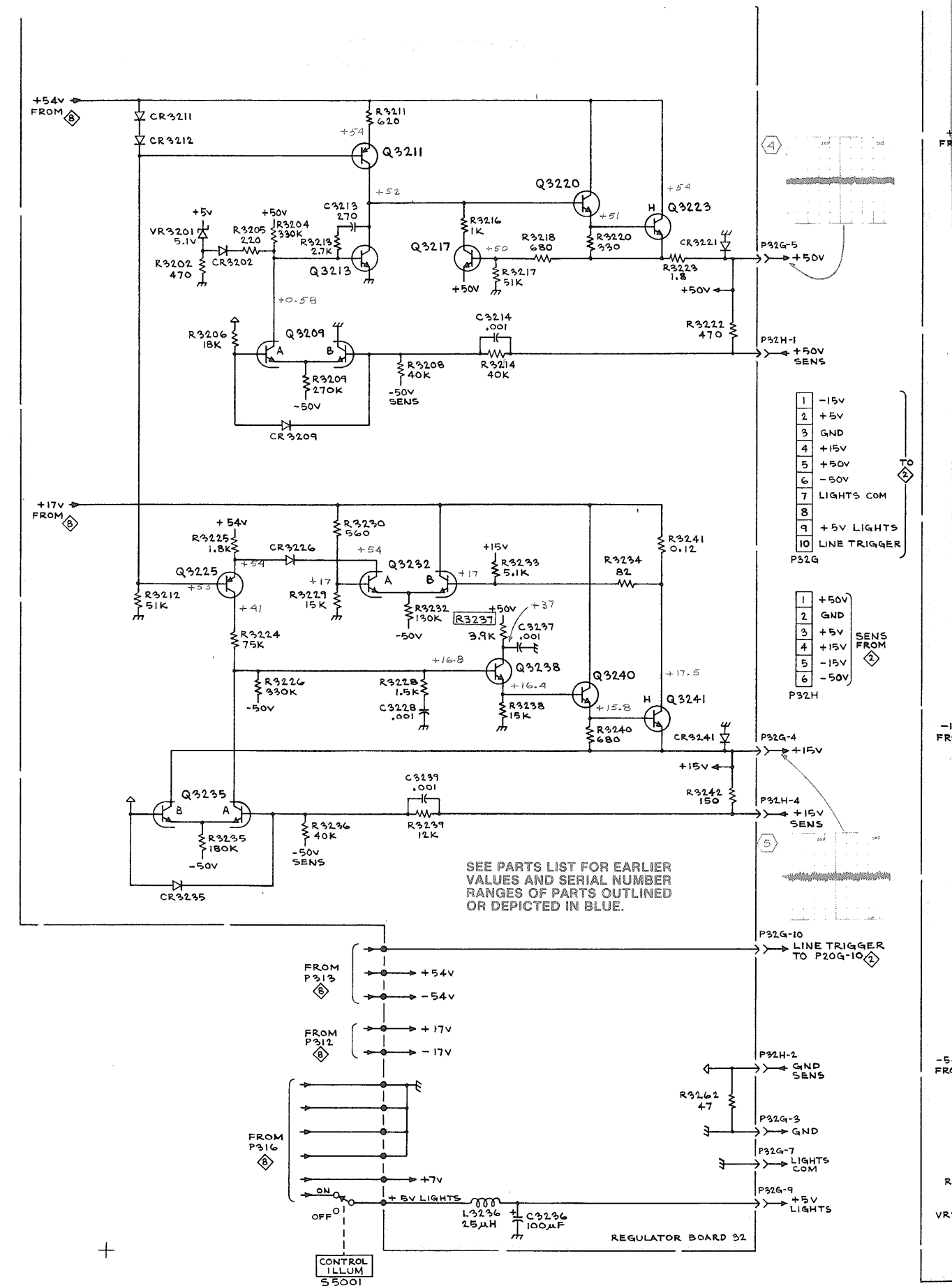

Measurements are

with 7A22 Base, and

meter (test stem), or

in B HORIZ selector set for

source.

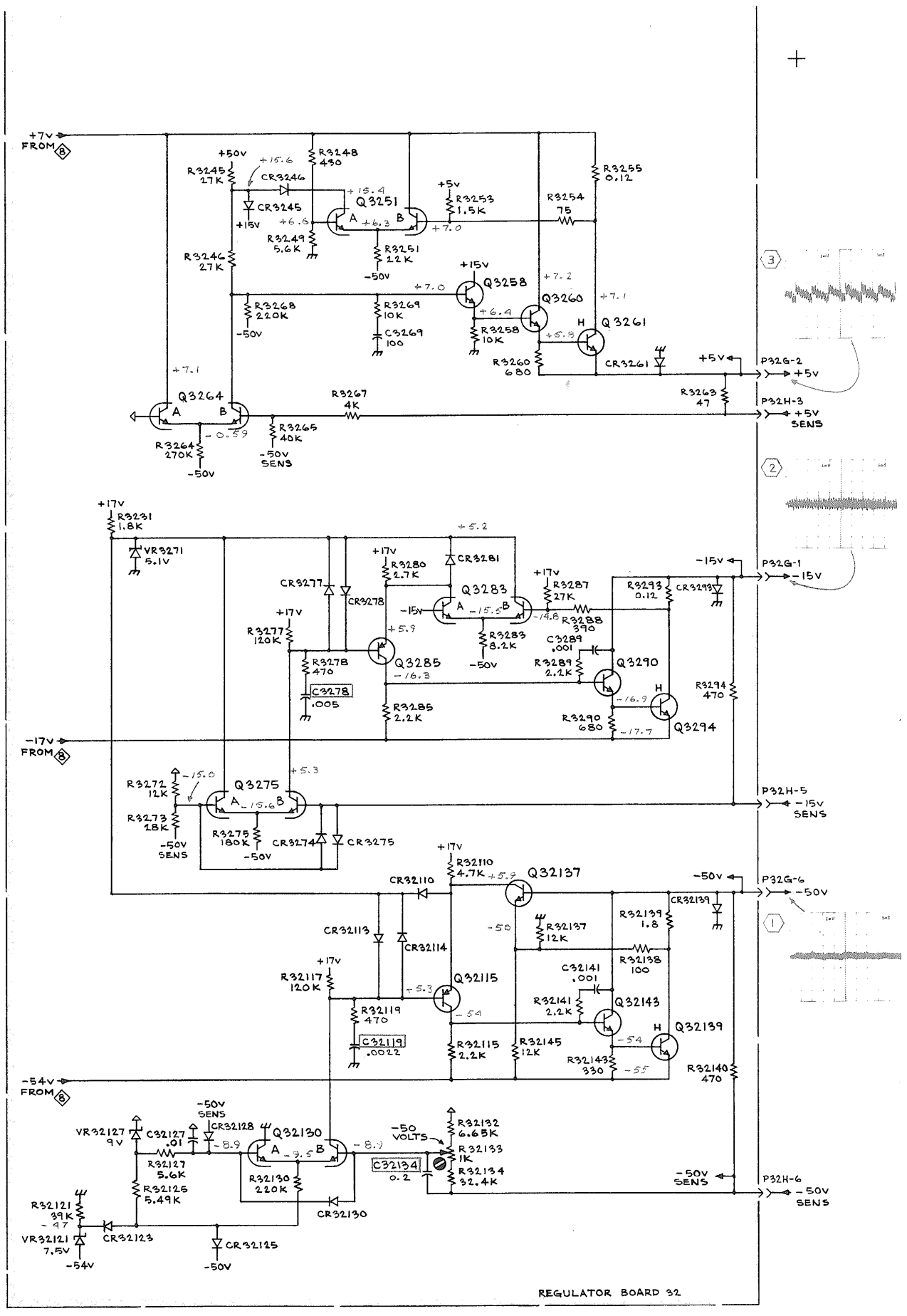
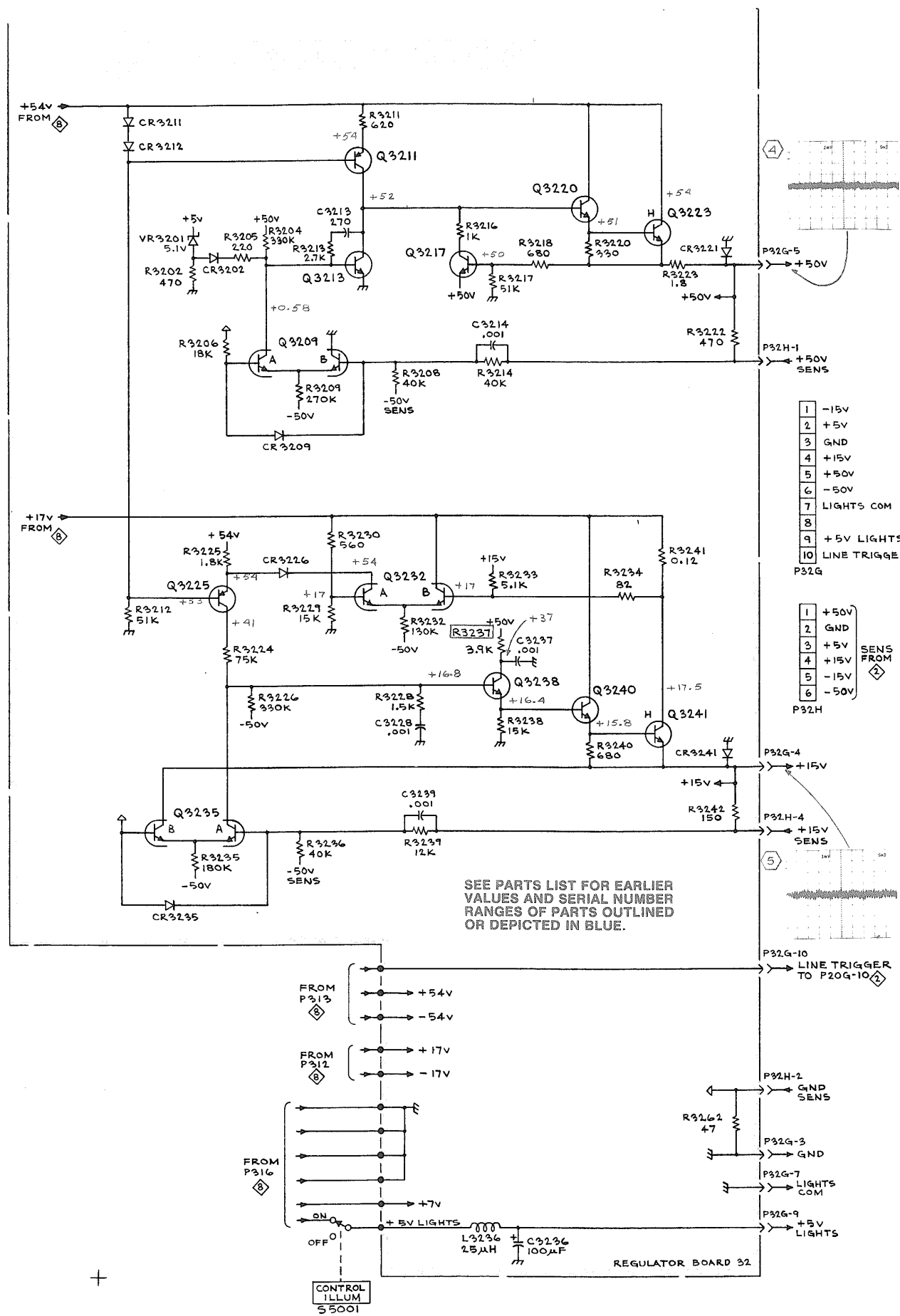

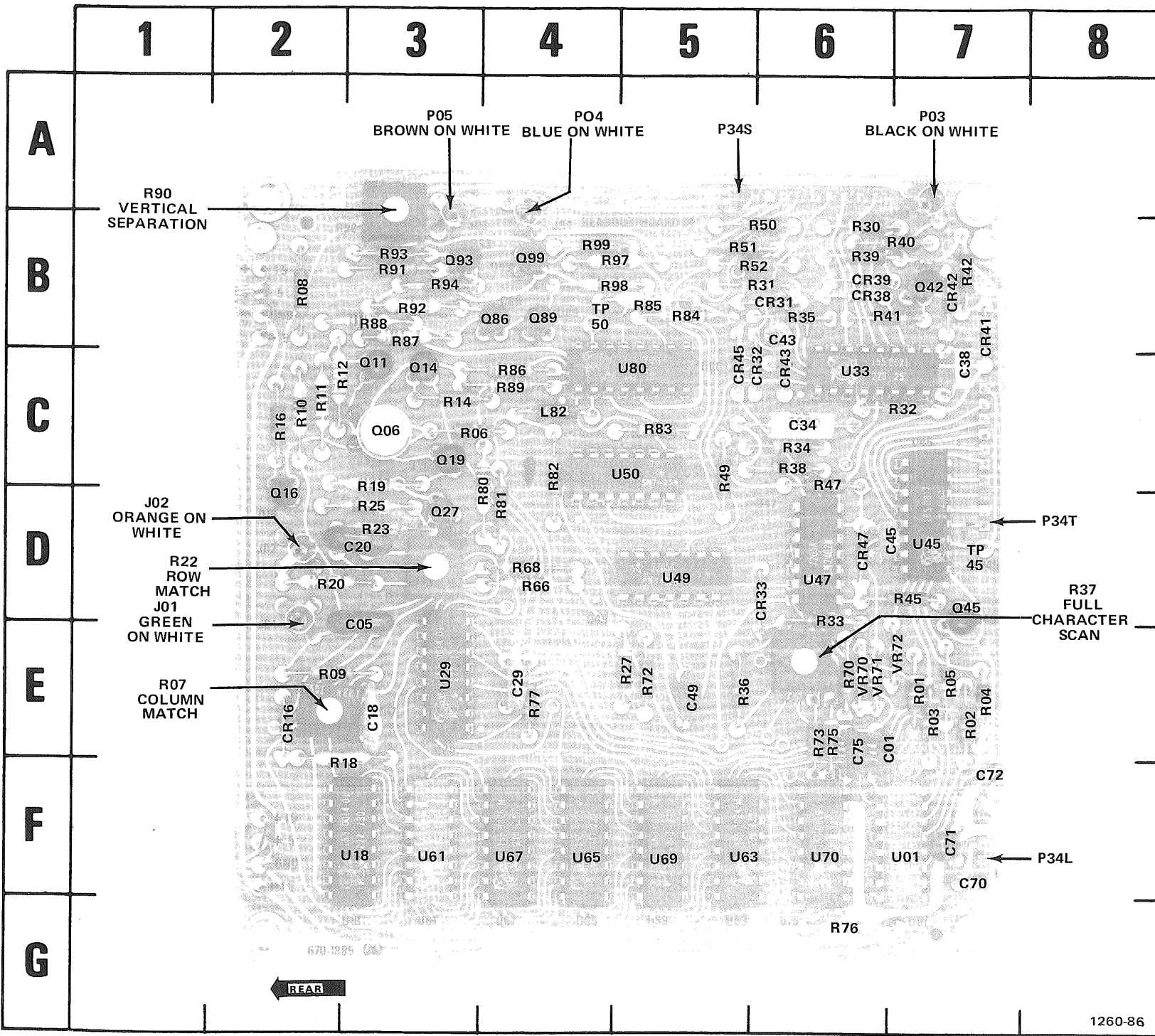
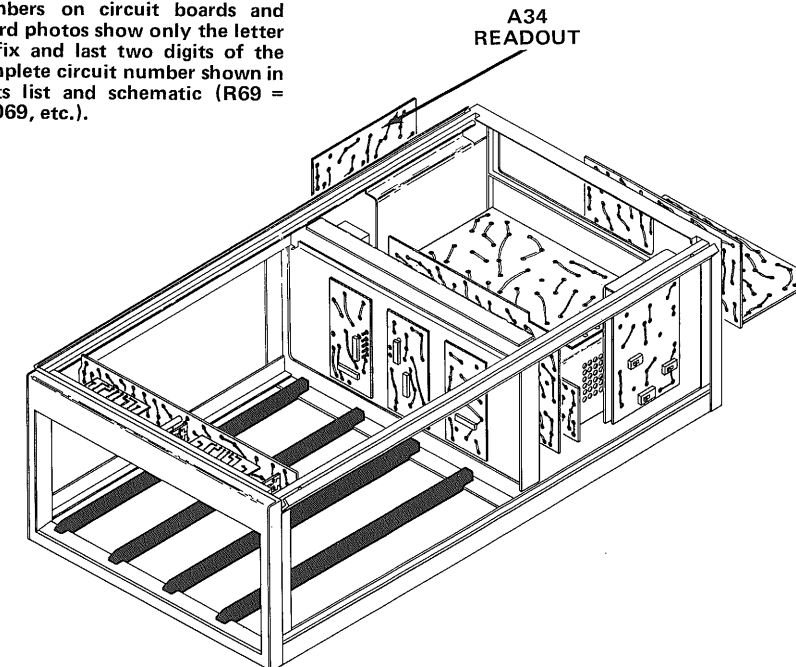

Fig. 6-18. A34-Readout circuit board.

CKT NO	GRID LOC	CKT NO	GRID LOC	CKT NO	GRID LOC	CKT NO	GRID LOC	CKT NO	GRID LOC	CKT NO	GRID LOC	CKT NO	GRID LOC	CKT NO	GRID LOC
C01	6E	CR33	6D	P34S	5A	R03	7E	R27	5E	R51	5B	R88	3B	U45	7D
C05	3E	CR38	6B	P34T	7D	R04	7E	R30	6B	R52	6B	R89	4C	U47	6D
C18	3E	CR39	6B			R05	7E	R31	6B	R66	4D	R90	3A	U49	5D
C20	3D	CR41	7B	Q06	3C	R06	3C	R32	7C	R68	4D	R91	3B	U50	5C
C29	4E	CR42	7B	Q11	3C	R07	2E	R33	6D	R70	6E	R92	3B	U61	3F
C34	6C	CR43	6C	Q14	3C	R08	2B	R34	6C	R72	5E	R93	3B	U63	5F
C38	7C	CR45	5C	Q16	2D	R09	2E	R35	6B	R73	6E	R94	3B	U65	4F
C43	6B	CR47	6D	Q19	3C	R10	2C	R36	5E	R75	6E	R97	4B	U67	4F
C45	6D			Q27	3D	R11	2C	R37	6E	R76	6G	R98	4B	U69	5F
C49	5E	J01	2E	Q42	7B	R12	2C	R38	6C	R77	4E	R99	4B	U70	6F
C70	7F	J02	2D	Q45	7D	R14	3C	R39	6B	R80	3D			U80	5C
C71	7F			Q86	4B	R16	2C	R40	7B	R81	4D	TP45	7D		
C72	7F	L82	4C	Q89	4B	R18	2E	R41	6B	R82	4C	TP50	4B	VR70	6E
C75	6E			Q93	3B	R19	3C	R42	7B	R83	5C			VR71	6E
CR16	2E	P03	7A	Q99	4B	R20	2D	R45	7D	R84	5B	U01	7F	VR72	7E
CR31	6B	P04	4A			R22	3D	R47	6C	R85	5B	U18	3F		
CR32	6C	P05	3A	R01	7E	R23	3D	R49	5C	R86	4C	U29	3E		
		P34L	7F	R02	7E	R25	3D	R50	6B	R87	3B	U33	6C		

NOTE
To conserve space, the circuit numbers on circuit boards and board photos show only the letter prefix and last two digits of the complete circuit number shown in parts list and schematic (R69 = R1069, etc.).



VOLTAGE AND WAVEFORM CONDITIONS

The voltages and waveforms shown on this diagram were obtained with the test set-ups and equipment given below. These measurements are not absolute and may vary between instruments.

Recommended Test Equipment

Item	Specifications	Examples of Applicable Test Equipment
Test oscilloscope	Frequency response, dc to 65 MHz; deflection factor (with 10X probe), 20 mV to five V/division; fastest sweep rate, 100 μ s/division.	a. Tektronix 7603 Oscilloscope with 7A13 Differential Comparator, 7B50 Time Base, and P6053A Probe, or equivalent. (7A13 Differential Comparator used to obtain dc offset). b. Use item (a) above with 7A15A Amplifier in place of 7A13.
Dc voltmeter (non-loading digital multimeter)	Input impedance, 10 megohms; range, 0 to 20 V dc.	a. Tektronix 7D13 Digital Multimeter (test oscilloscope must have readout system), or equivalent. b. Fairchild Model 7050.

Test Set-Ups

7704A Under Test: No plug-in units installed.

Front-Panel Controls

Knob-type controls	Midrange
VERTICAL MODE	LEFT
A AND B TRIGGER SOURCE	VERT MODE
HORIZONTAL MODE	B

Internal Control (on A33-Signal Output board)

Readout Mode	Free-Run
--------------	----------

Test Equipment: Voltmeter common is connected to 7704A chassis ground. Test oscilloscope is externally triggered from TP3450.

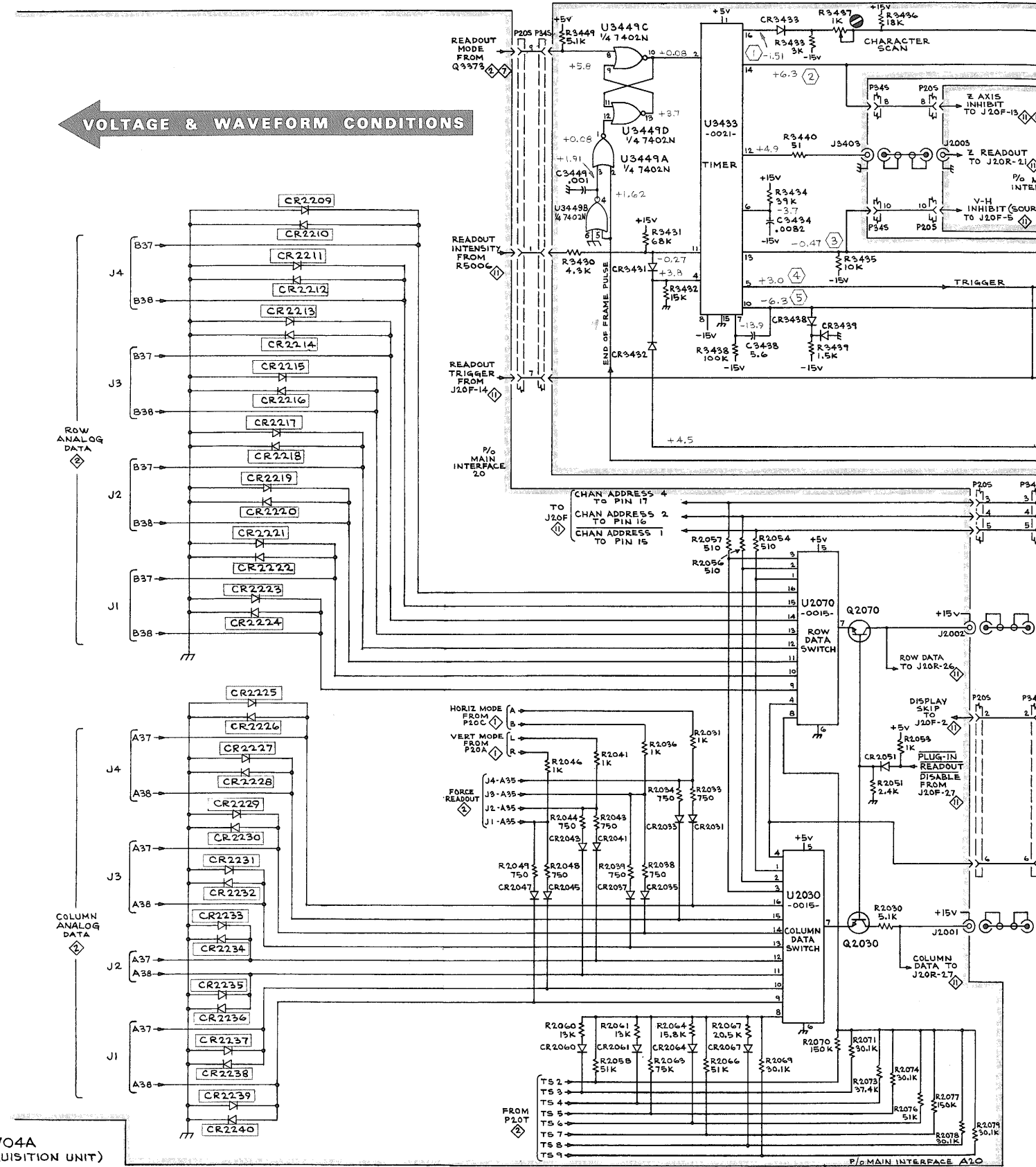
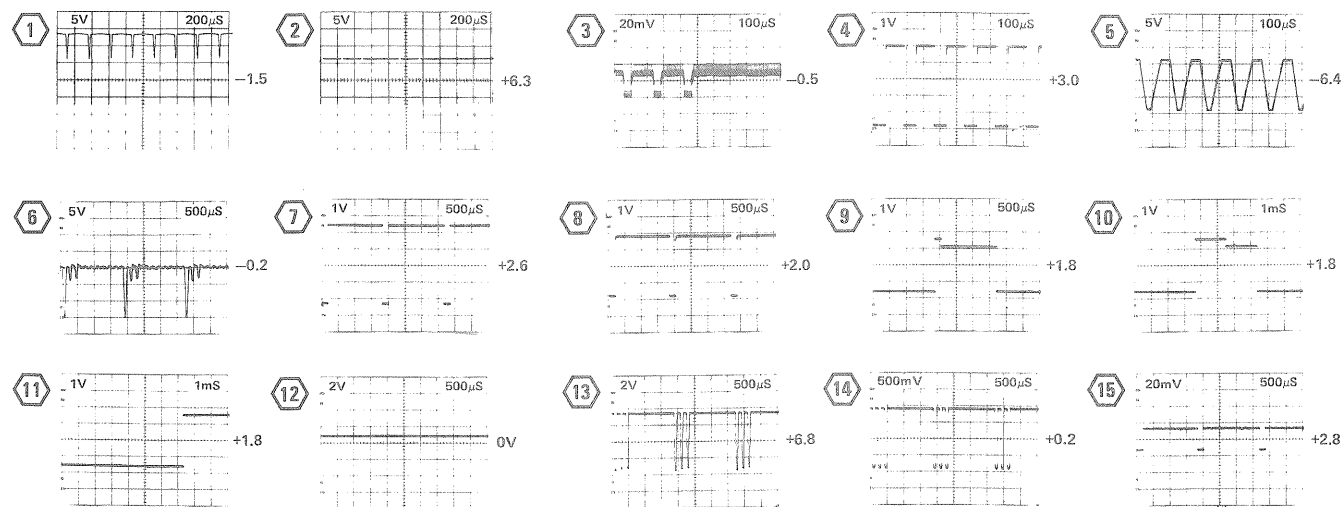

7704A (ACQUISITION UNIT)

Requirements are

th 7A13
base, and
3 Differ-
fset).

mplifier in

ter (test
item), or

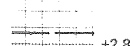
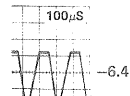

VOLTAGE & WAVEFORM CONDITIONS

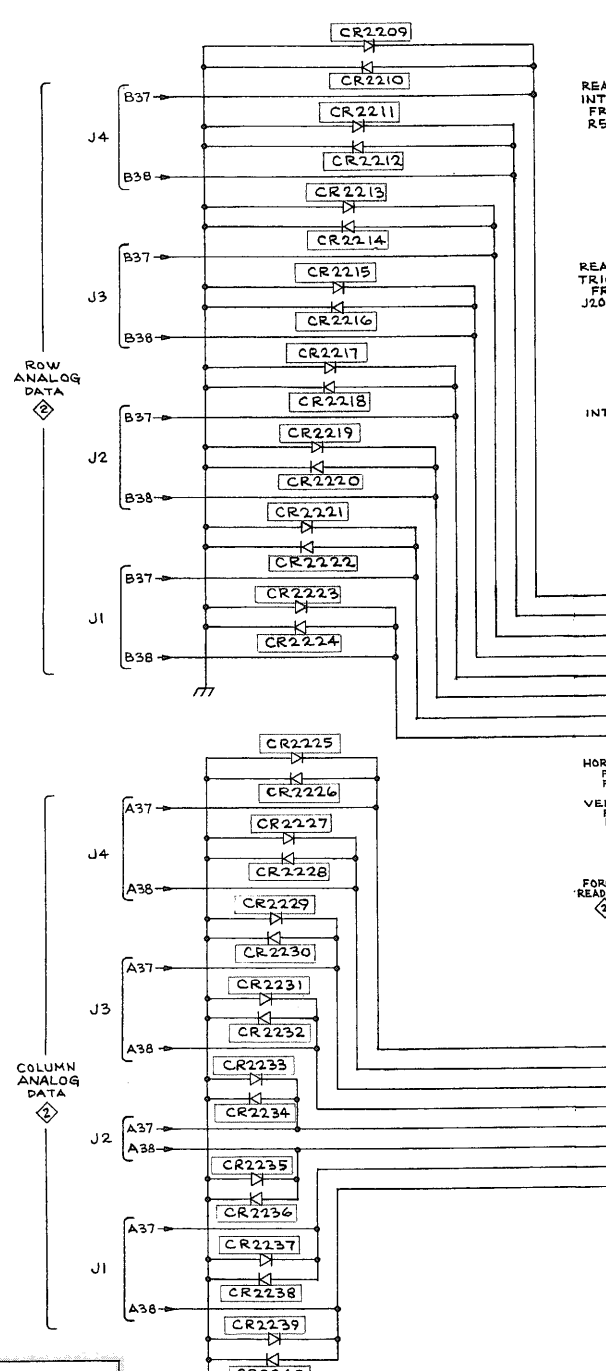

7704A
(ACQUISITION UNIT)

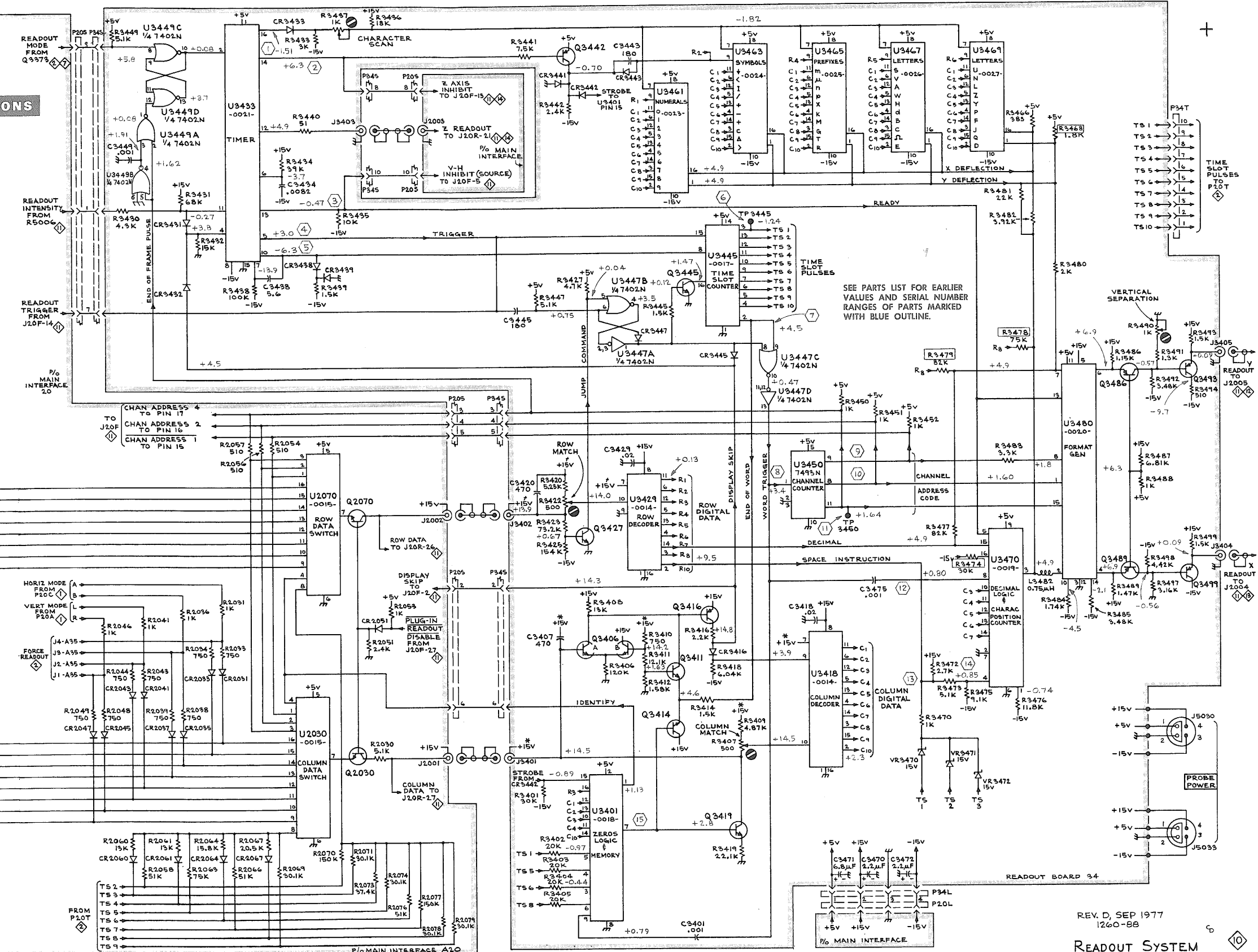

REV. D, SEP 1977
1260-88

READOUT SYSTEM

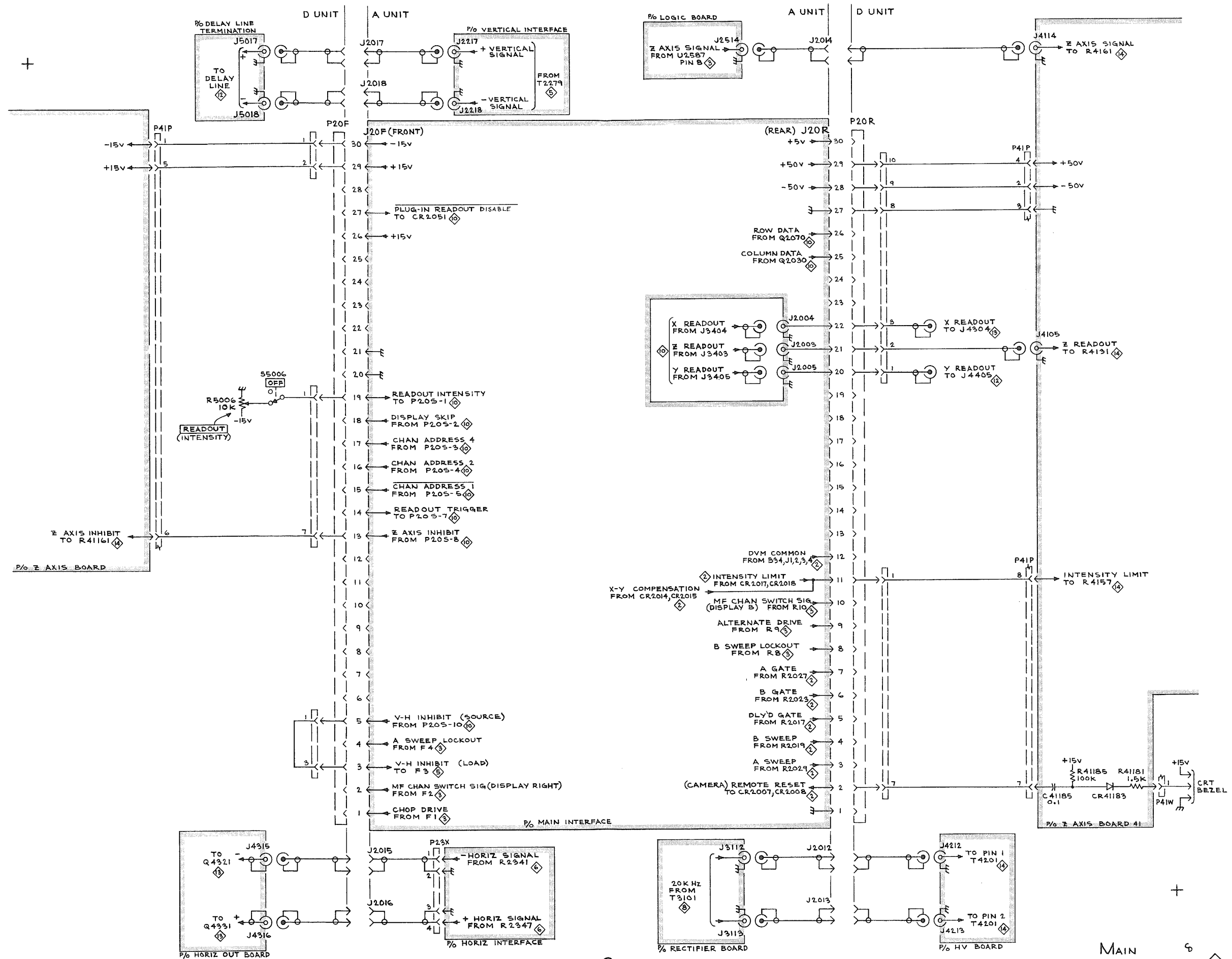

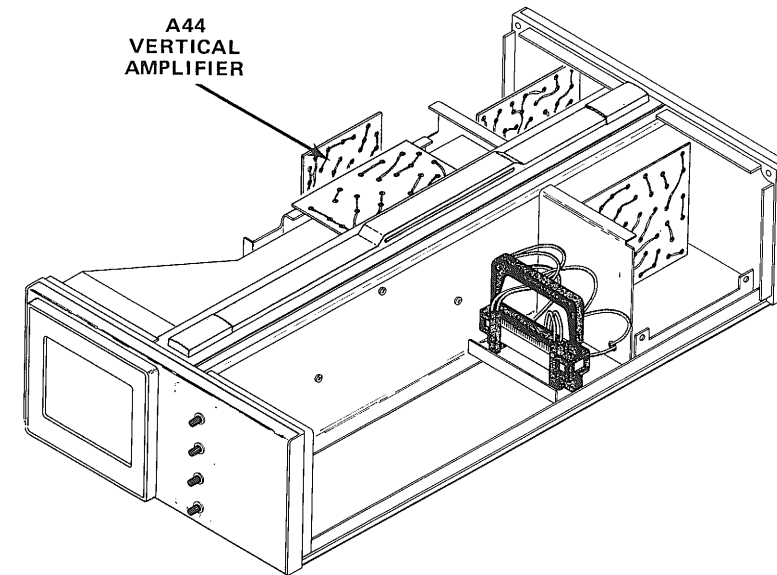
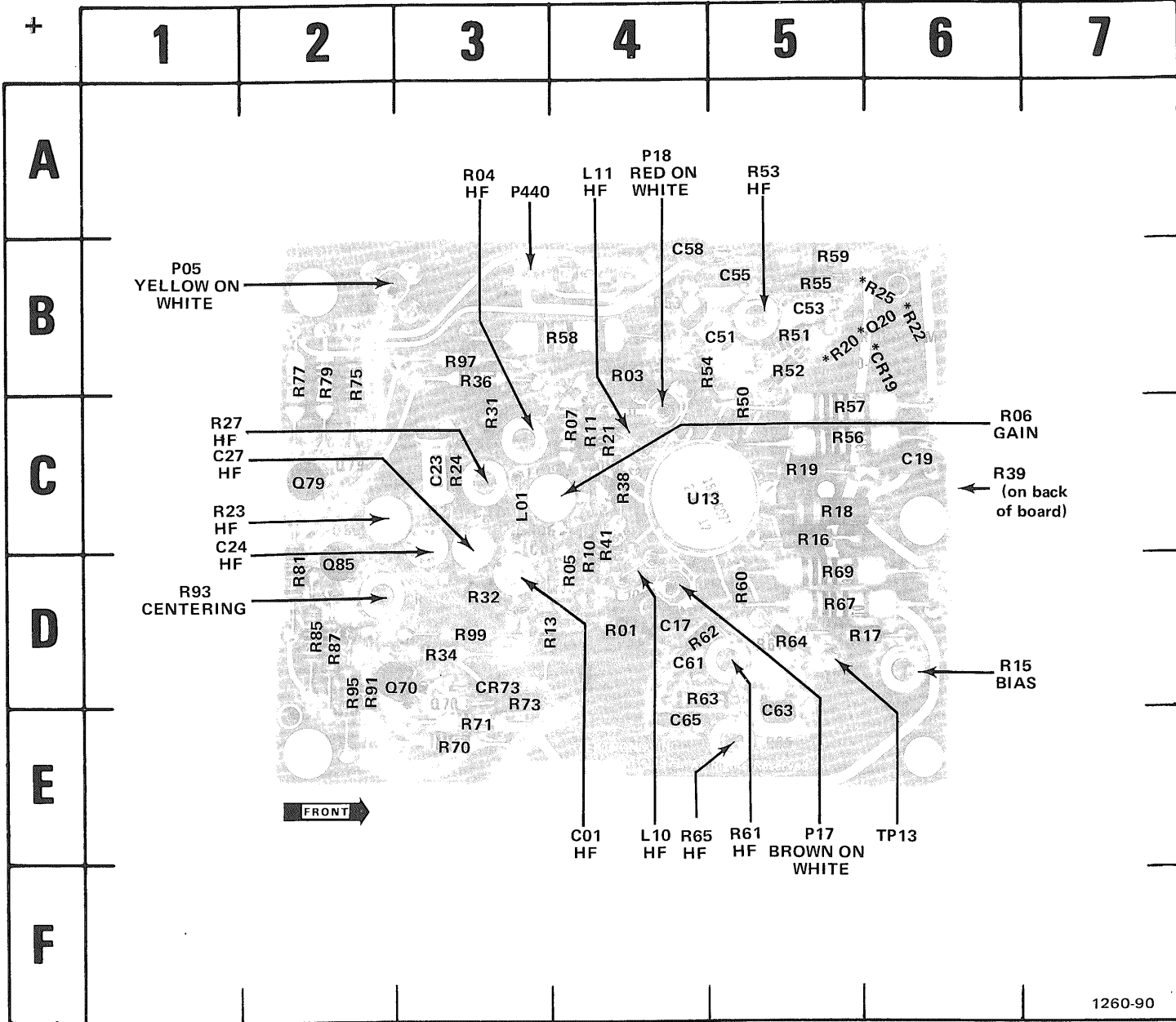

*See Parts List for serial number ranges.

Fig. 6-20. A44 - Vertical Amplifier circuit board.

REV. C, JUNE 1975

CKT NO	GRID LOC	CKT NO	GRID LOC	CKT NO	GRID LOC	CKT NO	GRID LOC	CKT NO	GRID LOC	CKT NO	GRID LOC	CKT NO	GRID LOC	CKT NO	GRID LOC
C01	3D	C63	5E	P18	4C	R06	4C	R23	2C	R52	5B	R63	4D	R81	2D
C17	4D	C65	4E	P44D	3B	R07	4C	R24	3C	R53	5B	R64	5D	R85	2D
C19	6C					R10	4C	R27	3C	R54	4B	R65	5E	R87	2D
C23	3C	CR73	3D	Q70	3D	R11	4C	R31	3D	R55	5B	R67	5D	R91	2D
C24	3C			Q79	2C	R13	3D	R32	3D	R56	5C	R69	5D	R93	2D
C27	3C	L01	3C	Q85	2D	R15	6D	R34	3D	R57	5C	R70	3E	R95	2D
C51	5B	L10	4D			R16	5C	R36	3B	R58	4B	R71	3E	R97	3B
C53	5B	L11	4C	R01	4D	R17	6D	R38	4C	R59	5B	R73	3D	R99	3D
C55	5B			R03	4B	R18	5C	R41	4C	R60	5D	R75	2B		
C58	4B	P05	2B	R04	3C	R19	5C	R50	5C	R61	5D	R77	2B	TP13	5D
C61	4D	P17	4D	R05	4D	R21	4C	R51	5B	R62	4D	R79	2B	U13	4C

VOLTAGE AND WAVEFORM CONDITIONS

The voltages and waveforms shown on this diagram were obtained with the test set-ups and equipment given below. These measurements are not absolute and may vary between instruments.

Recommended Test Equipment

Item	Specifications	Examples of Applicable Test Equipment
Test oscilloscope	Frequency response, dc to 65 MHz and selectable reduced bandwidth to five or 10 MHz; deflection factor (with 10X probe), 20 mV to two V/division; sweep rate, 500 μ s/division.	a. Tektronix 7603 Oscilloscope with 7A13 Differential Comparator, 7B50 Time Base, and P6053A Probe, or equivalent. (7A13 Differential Comparator used to obtain dc offset). b. Use item (a) above with 7A15A Amplifier in place of 7A13.
Dc voltmeter (non-loading digital multimeter)	Input impedance, 10 megohms; range, 0 to 100 V dc.	a. Tektronix 7D13 Digital Multimeter (test oscilloscope must have readout system), or equivalent. b. Fairchild Model 7050.

Test Set-Up

7704A Under Test: Amplifier unit installed in LEFT VERT compartment. No signal applied for voltage measurements; trace is centered. For waveforms, the 7704A Calibrator signal is applied to the amplifier unit to obtain a centered, four-division display. A time-base unit is installed in the B HORIZ compartment. The time-base is set for auto triggering at a 0.1-ms/division sweep rate.

Front-Panel Controls

Knob-type controls	Midrange
VERTICAL MODE	LEFT
A AND B TRIGGER SOURCE	VERT MODE
HORIZONTAL MODE	B

Test Equipment: Voltmeter common is connected to 7704A chassis ground. Test oscilloscope is externally triggered from 7704A +GATE OUT connector. * by waveform indicates that test oscilloscope was set for reduced bandwidth.

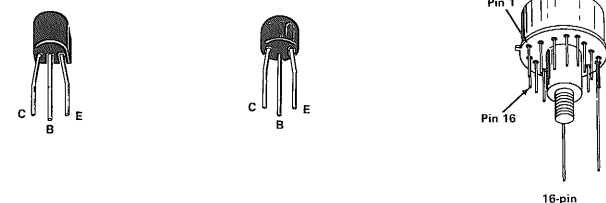
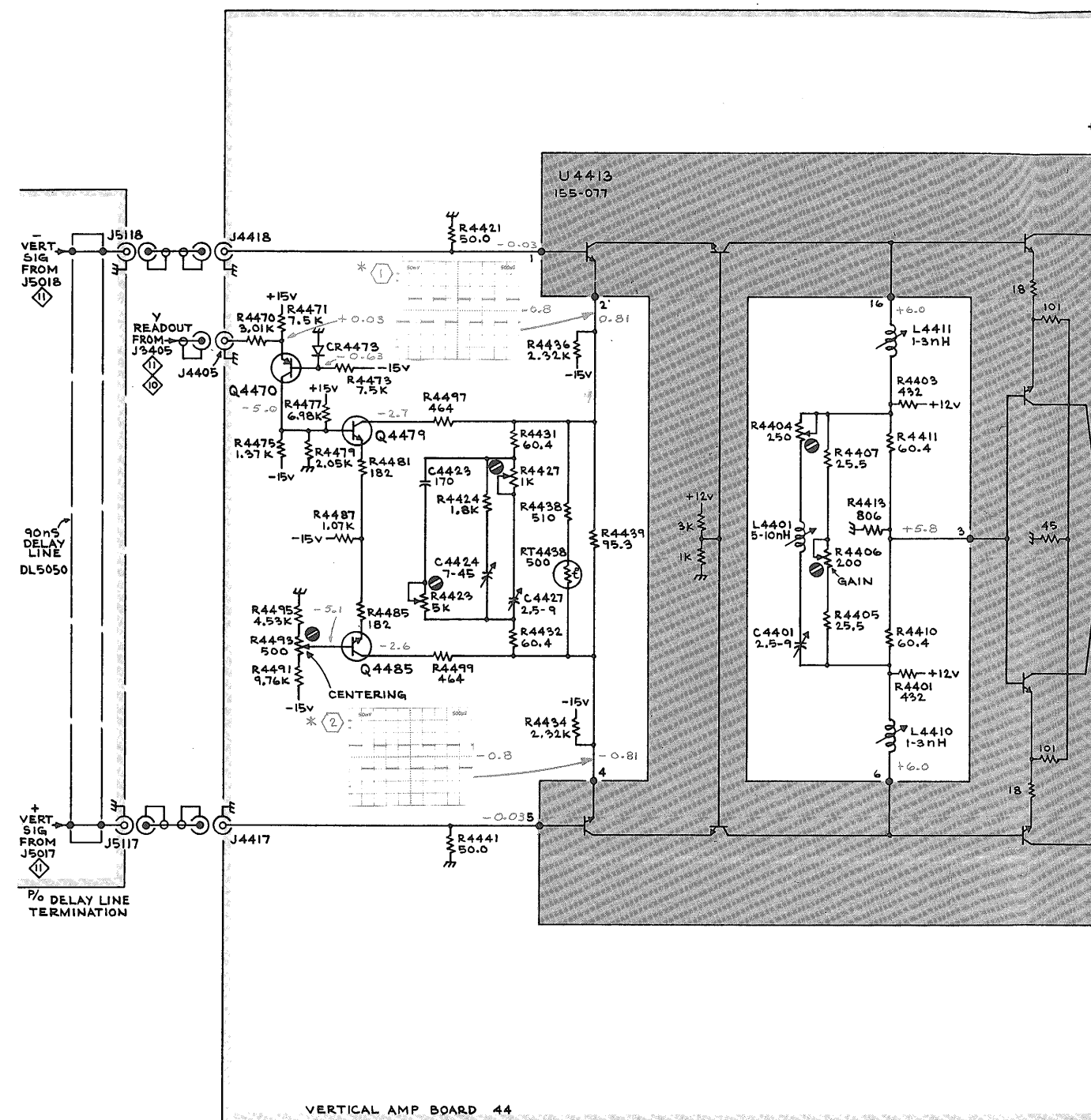

7704A (DISPLAY UNIT)

REV. D, SEP 1960-9

Measurements are

with 7A13 Base, and 3 Differential Offset).

Amplifier in

Center (test stem), or

Centered. For it is installed

+GATE OUT

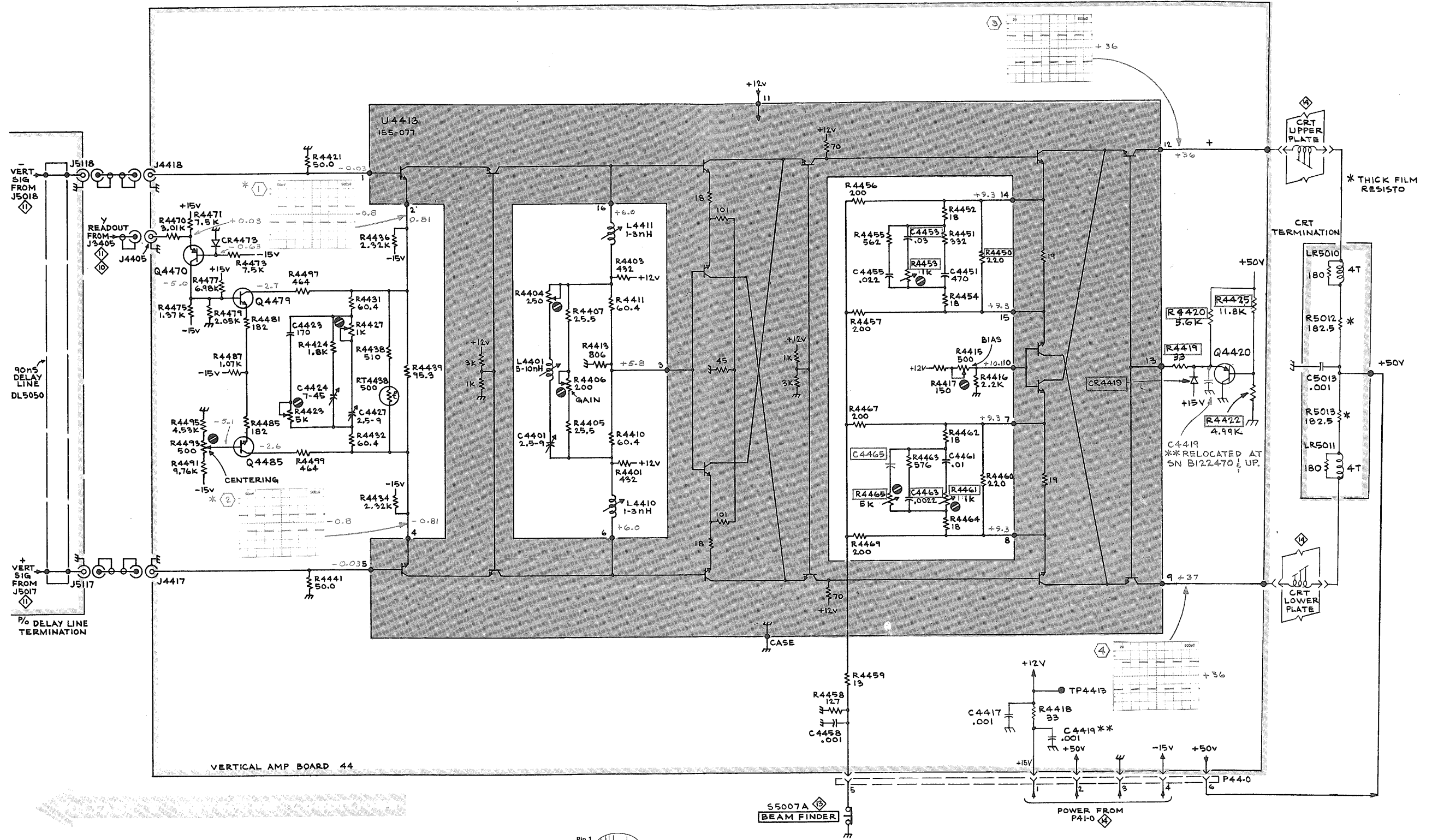

7704A (DISPLAY UNIT)

REV. D, SEP 1977
1260-91

VERTICAL AMPLIFIER
6-25

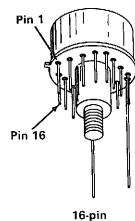
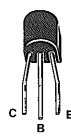

SEE PARTS LIST FOR EARLIER VALUES AND SERIAL NUMBER RANGES OF PARTS OUTLINED OR DEPICTED IN BLUE.

5

12

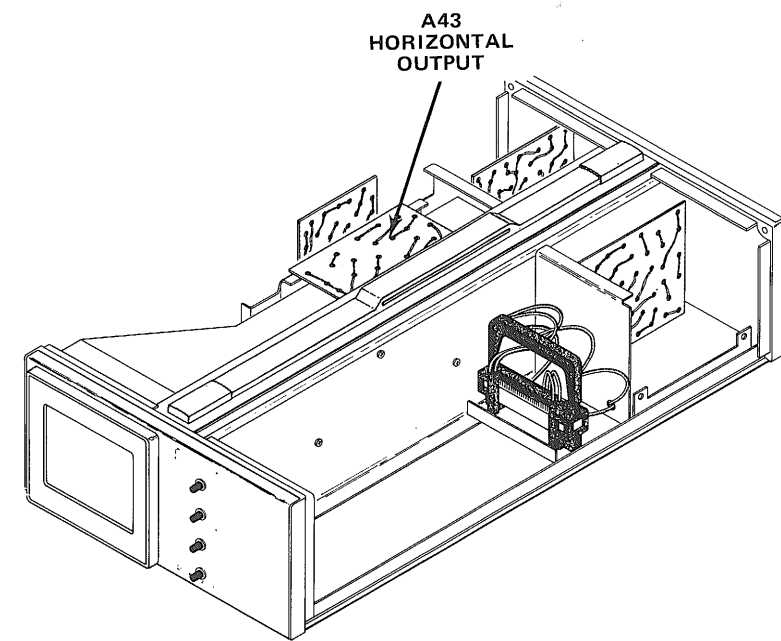
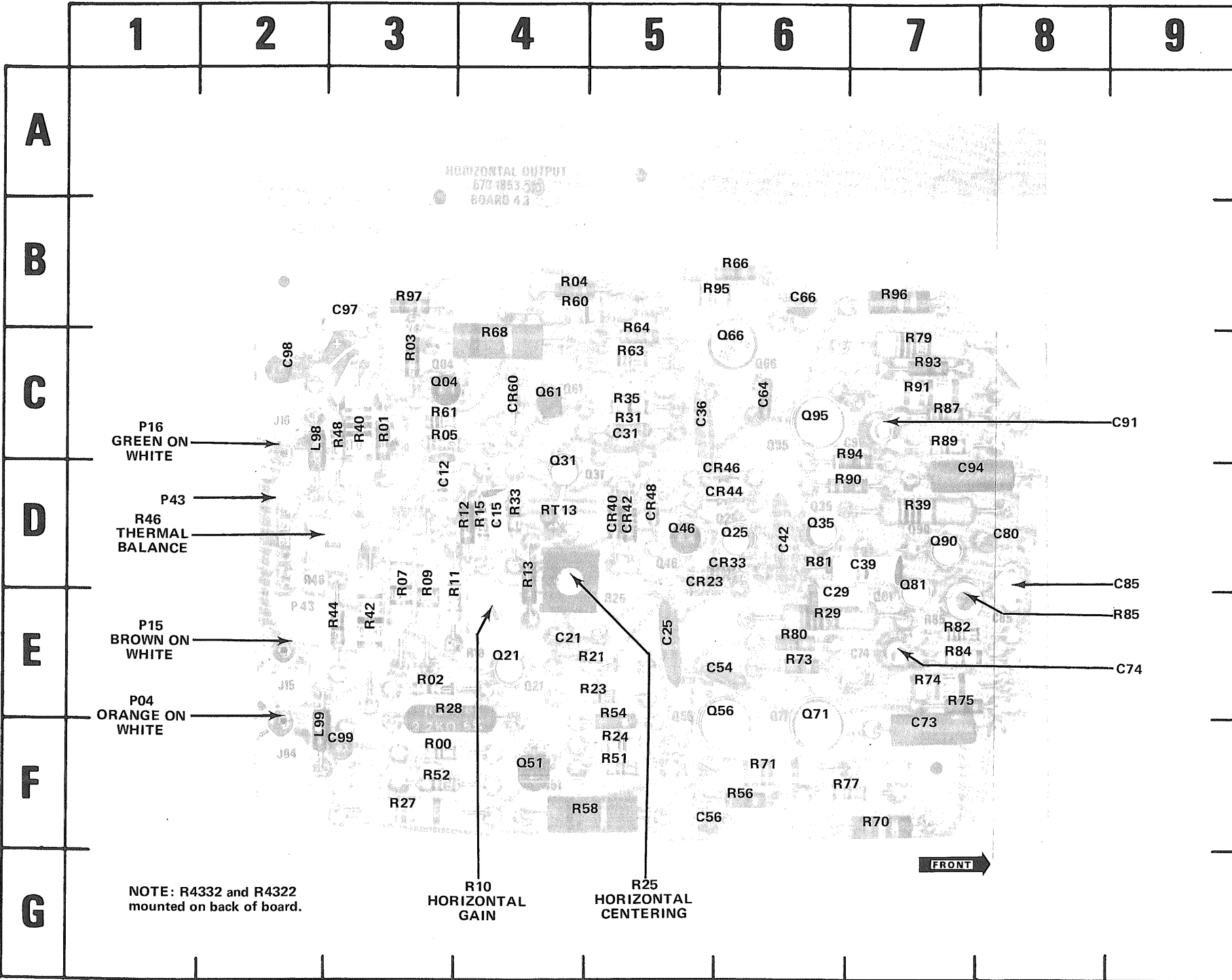

Fig. 6-21. A43-Horizontal Output circuit board.

CKT NO	GRID LOC	CKT NO	GRID LOC	CKT NO	GRID LOC	CKT NO	GRID LOC	CKT NO	GRID LOC	CKT NO	GRID LOC	CKT NO	GRID LOC	CKT NO	GRID LOC
C12	3D	C91	7C	P04	2E	R66	6C	R10	4E	R35	5C	R63	5C	R84	7E
C15	4D	C94	7D	P15	2E	Q71	6E	R11	3D	R39	7D	R64	5C	R85	7E
C21	4E	C97	3B	P16	2C	Q81	7D	R12	4D	R40	3C	R66	6B	R87	7C
C25	5E	C99	3F	P43	2D	Q90	7D	R13	4D	R42	3E	R68	4C	R89	7C
C31	5C					Q95	6C	R14	4D	R44	3E	R70	7F	R90	7D
C36	5C	CR23	5D	Q04	3C			R21	5E	R46	2D	R71	6F	R91	7C
C39	7D	CR33	6D	Q21	4E	R00	3F	R23	5E	R48	3C	R73	6E	R93	7C
C42	6D	CR40	5D	Q25	6D	R01	3C	R24	5F	R51	5F	R74	7E	R94	7C
C54	6E	CR42	5D	Q31	4C	R02	3E	R25	4D	R52	3F	R75	7E	R95	5B
C56	5F	CR44	6D	Q35	6D	R03	3C	R27	3F	R54	5E	R77	6F	R96	7B
C64	5F	CR46	6D	Q46	5D	R04	4B	R28	3E	R56	6F	R79	7C	R97	3B
C66	6B	CR48	5D	Q51	4F	R05	3C	R29	6E	R58	5F	R80	6E		
C73	7E	CR60	4C	Q56	6E	R07	3D	R31	5C	R60	4B	R81	6D	RT13	4D
C74	7E			Q61	4C	R09	3D	R33	4D	R61	3C	R82	7E		
C80	8D	L98	2C												
C85	8D	L99	2F												

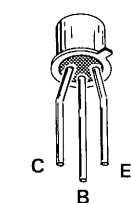
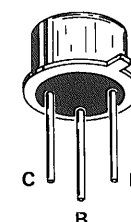
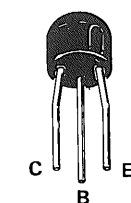
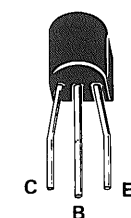
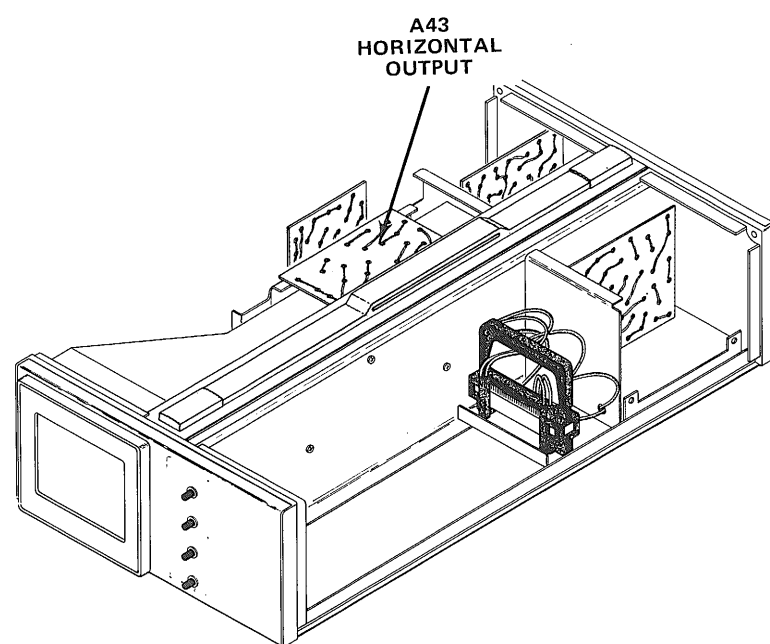
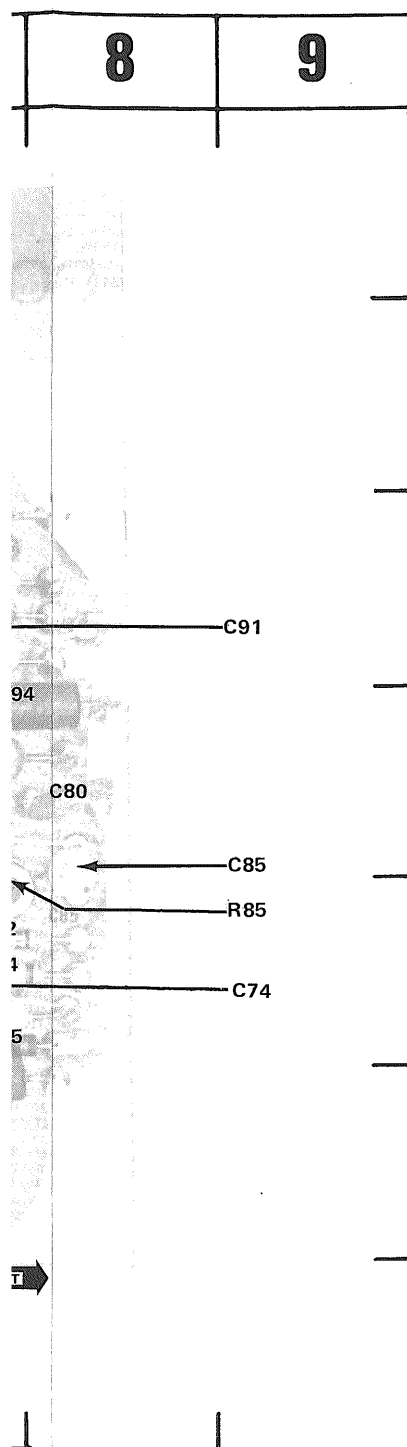

Fig. 6-22. Electrode configuration for semiconductors shown on diagram 13.

VOLTAGE AND WAVEFORM CONDITIONS

The voltages and waveforms shown on this diagram were obtained with the test set-ups and equipment given below. These measurements are not absolute and may vary between instruments.

Recommended Test Equipment

Item	Specifications	Examples of Applicable Test Equipment
Test oscilloscope	Frequency response, dc to 65 MHz; deflection factor (with 10X probe), 100 mV to 10 V/division; sweep rate, 500 μ s/division.	a. Tektronix 7603 Oscilloscope with 7A13 Differential Comparator, 7B50 Time Base, and P6053A Probe, or equivalent. (7A13 Differential Comparator used to obtain dc offset). b. Use item (a) above with 7A15A Amplifier in place of 7A13.
Dc voltmeter (non-loading digital multimeter)	Input impedance, 10 megohms; range, 0 to 200 V dc.	a. Tektronix 7D13 Digital Multimeter (test oscilloscope must have readout system), or equivalent. b. Fairchild Model 7050.

Test Set-Up

7704A Under Test: Amplifier unit installed in LEFT VERT compartment. No signal applied for voltage measurements. For waveforms, the 7704A Calibrator signal is applied to the amplifier unit to obtain a four-division display. A time-base unit is installed in the B HORIZ compartment. The time-base is set for auto triggering at a 0.1-ms/division sweep rate.

Front-Panel Controls

Knob-type controls	Midrange
VERTICAL MODE	LEFT
A AND B TRIGGER SOURCE	VERT MODE
HORIZONTAL MODE	B

Test Equipment: Voltmeter common is connected to 7704A chassis ground. Test oscilloscope is externally triggered from 7704A +GATE OUT connector.

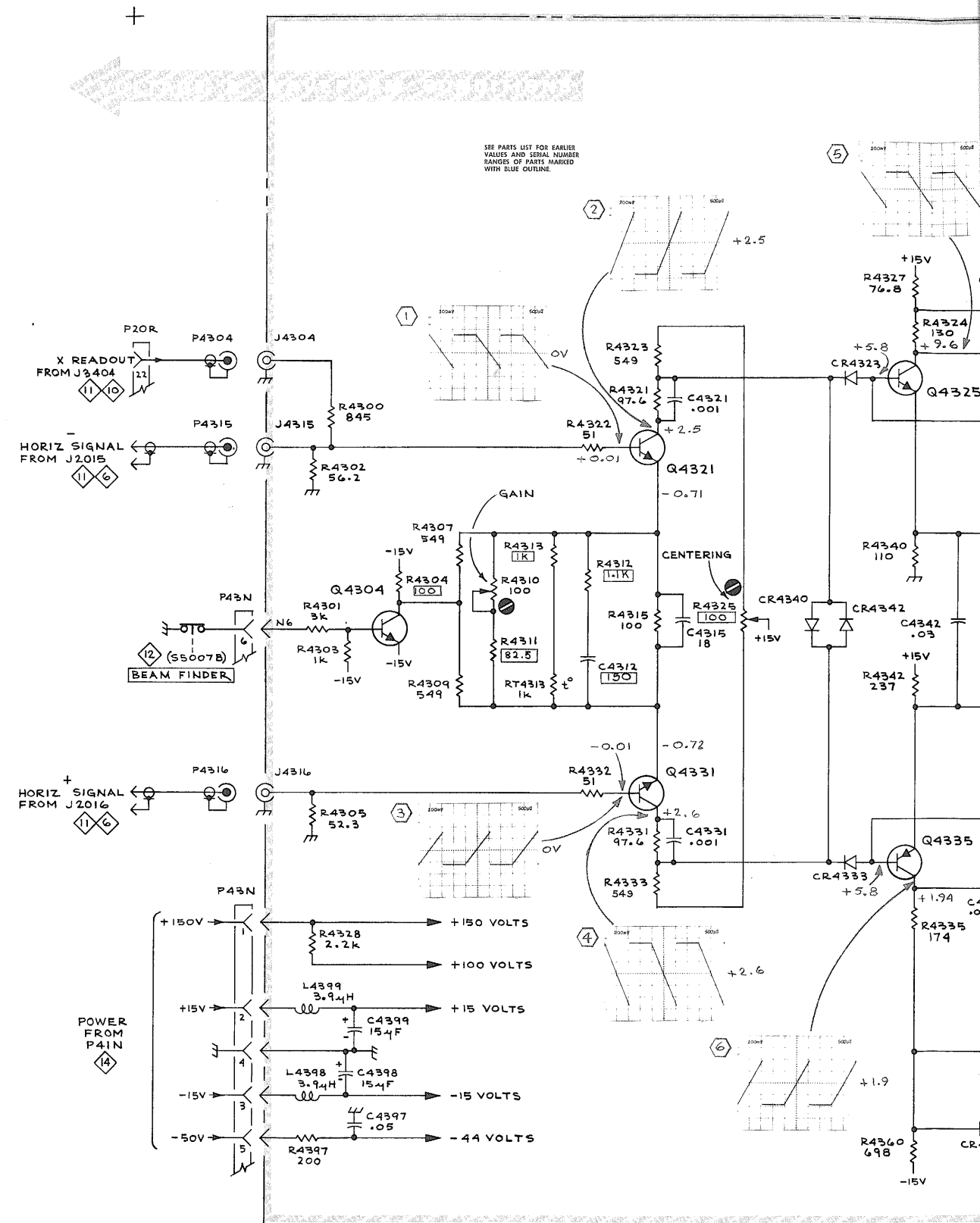

7704A (DISPLAY UNIT)

REV. D, NOV. 1974

Requirements are

h 7A13 base, and 3 Differential-set).

plier in

ter (test tem), or

reforms, the e B HORIZ

GATE OUT

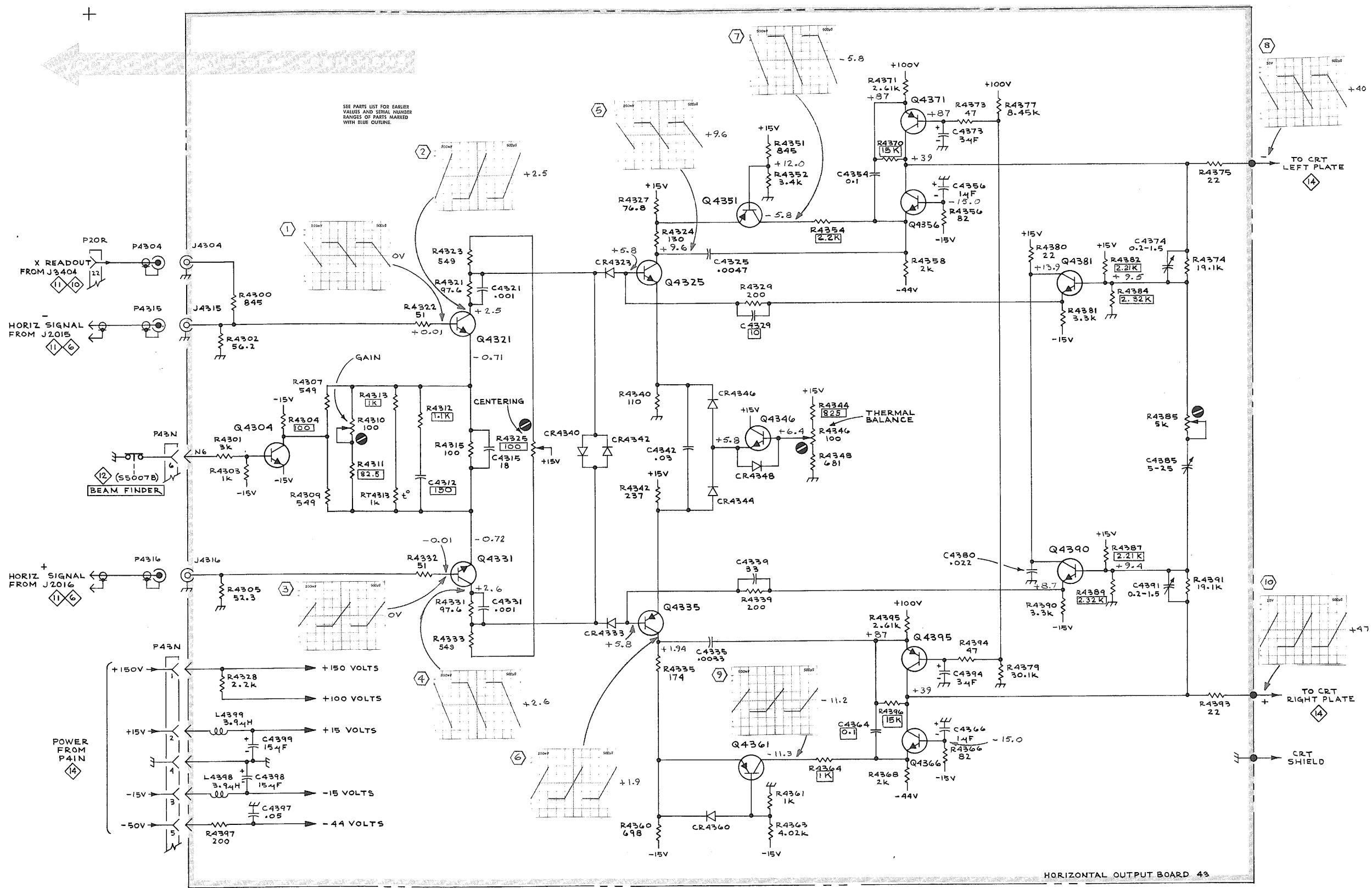

7704A (DISPLAY UNIT)

REV. D, NOV. 1974

HORIZONTAL AMPLIFIER 13 DEH

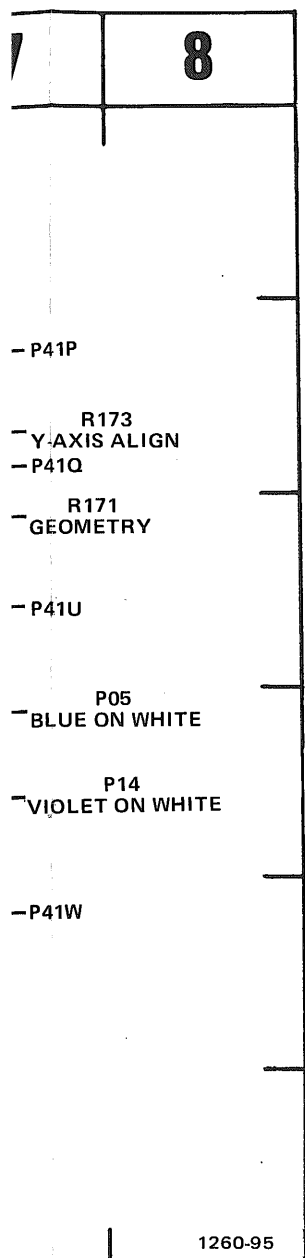

NOTE
To conserve space, the circuit numbers on circuit boards and board photos show only the letter prefix and last two digits of the complete circuit number shown in parts list and schematic (R69 = R1069, etc.).

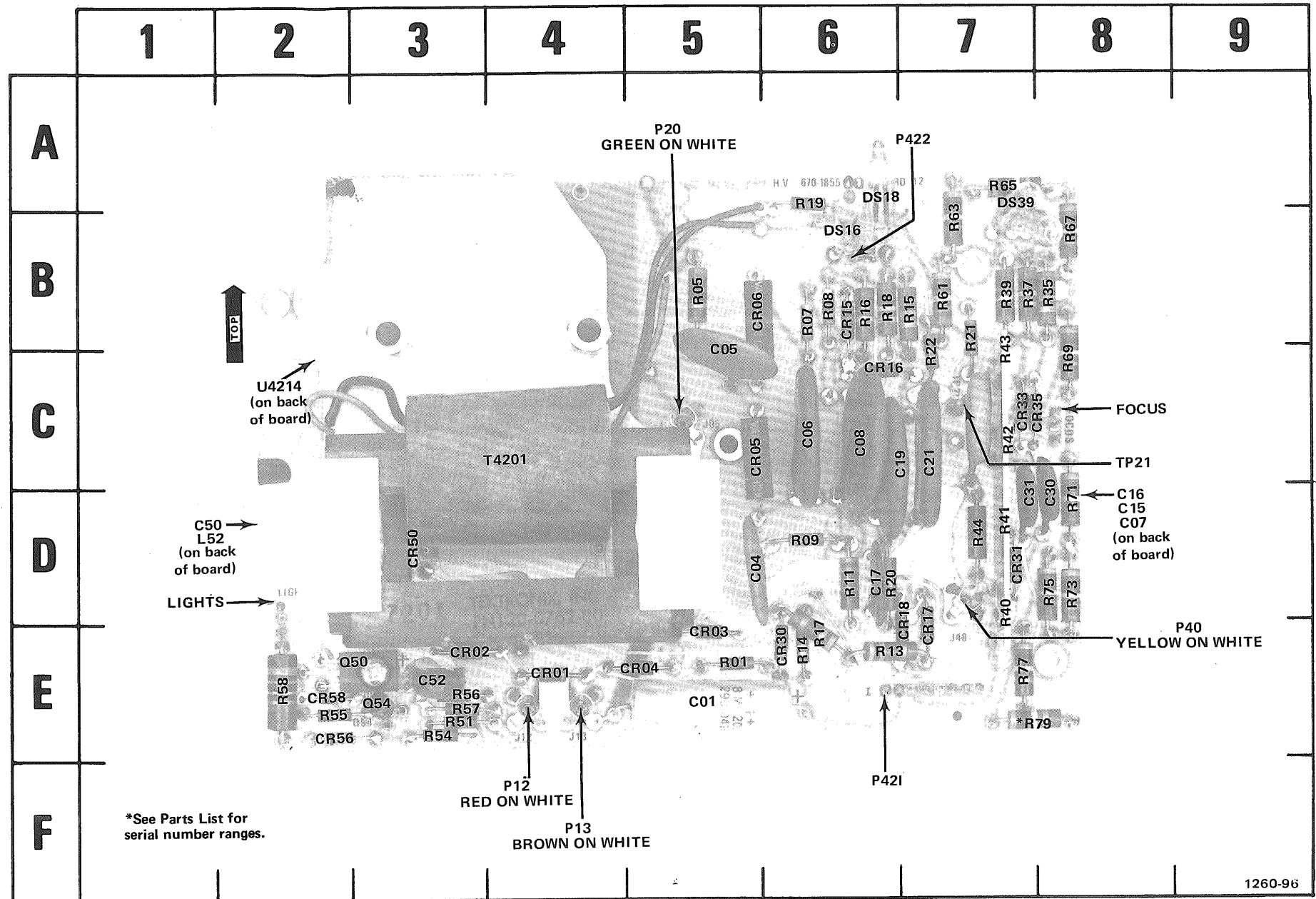

Fig. 6-24. A42-HV circuit board.

*See Parts List for serial number ranges.

CKT NO	GRID LOC	CKT NO	GRID LOC
R127	2C	TP120	3C
R129	2B	U10	6E
R131	2D	VR42	3B
R133	2C	VR75	6D
R137	3E	VR107	3D
R150	3B	VR120	3E
R151	2D	VR121	3C
R153	2D		
R155	2E		
R161	5C		
R171	6B		
R173	6B		
R175	6C		
R176*	7C		
R177	6C		
R181	6D		
R185	6C		

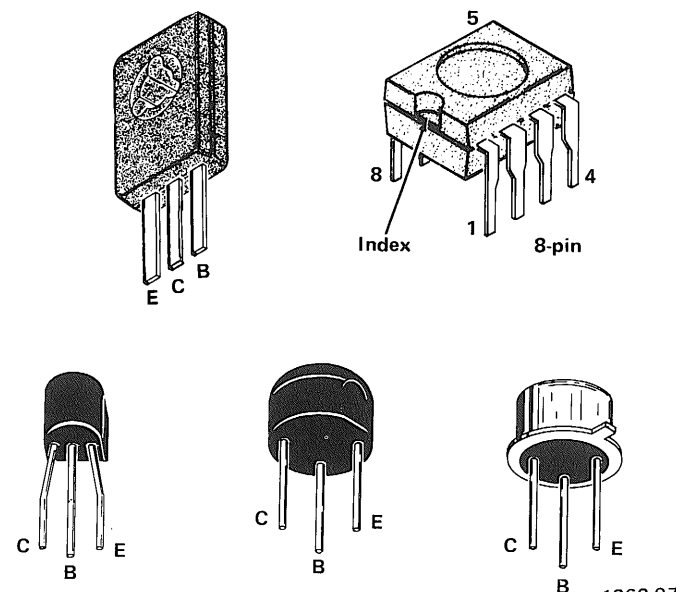

Fig. 6-25. Electrode configuration for semiconductors shown on diagram 14.

CKT NO	GRID LOC	CKT NO	GRID LOC	CKT NO	GRID LOC	CKT NO	GRID LOC	CKT NO	GRID LOC	CKT NO	GRID LOC	CKT NO	GRID LOC	CKT NO	GRID LOC
C01	5E	CR01	4E	CR31	7D	P12	4E	R05	5B	R19	6A	R44	7D	R71	8D
C04	5D	CR02	3E	CR33	7C	P13	4E	R07	6B	R20	6D	R51	3E	R73	8D
C05	5B	CR03	5E	CR35	7C	P20	5C	R08	6B	R21	7B	R54	3E	R75	8D
C06	6C	CR04	5E	CR50	3D	P40	7D	R09	6D	R22	7C	R55	2E	R77	7E
C08	6C	CR05	5C	CR56	2E	P421	6E	R11	6D	R35	8B	R56	3E	R79	7E
C17	6D	CR06	5B	CR58	2E	P422	6B	R13	6E	R37	7B	R57	3E		
C19	6C	CR15	6B					R14	6E	R39	7B	R58	2E	T4201	4C
C21	7C	CR16	6C	DS16	6B	Q50	3E	R15	7B	R40	7D	R61	7B		
C30	8D	CR17	7E	DS18	6A	Q54	3E	R16	6B	R41	7D	R63	7B	TP21	7C
C31	7D	CR18	6E	DS37	8B	R01	5E	R17	6E	R42	7C	R65	7A		
C52	3E	CR30	6E	DS39	7A			R18	6B	R43	7C	R67	8B		

VOLTAGE AND WAVEFORM CONDITIONS

The voltages and waveforms shown on this diagram were obtained with the test set-ups and equipment given below. These measurements are not absolute and may vary between instruments.

Recommended Test Equipment

Item	Specifications	Examples of Applicable Test Equipment
Test oscilloscope	Frequency response, dc to 65 MHz; deflection factor (with 10X probe), 100 mV to 10 V/division; sweep rate, 500 μ s/division.	a. Tektronix 7603 Oscilloscope with 7A13 Differential Comparator, 7B50 Time Base, and P6053A Probe, or equivalent. (7A13 Differential Comparator used to obtain dc offset). b. Use item (a) above with 7A15A Amplifier in place of 7A13.
Dc voltmeter (non-loading digital multimeter)	Input impedance, 10 megohms; range, 0 to 200 V dc.	a. Tektronix 7D13 Digital Multimeter (test oscilloscope must have readout system), or equivalent. b. Fairchild Model 7050.

Test Set-Up

7704A Under Test: Amplifier unit installed in LEFT VERT compartment. No signal applied for voltage measurements. For waveforms, the 7704A Calibrator signal is applied to the amplifier unit to obtain a four-division display. A time-base unit is installed in the B HORIZ compartment. The time-base is set for auto triggering at a 0.1-ms/division sweep rate.

Front-Panel Controls

Knob-type controls	Midrange
VERTICAL MODE	LEFT
A AND B TRIGGER SOURCE	VERT MODE
HORIZONTAL MODE	B

Test Equipment: Voltmeter common is connected to 7704A chassis ground. Test oscilloscope is externally triggered from 7704A +GATE OUT connector.

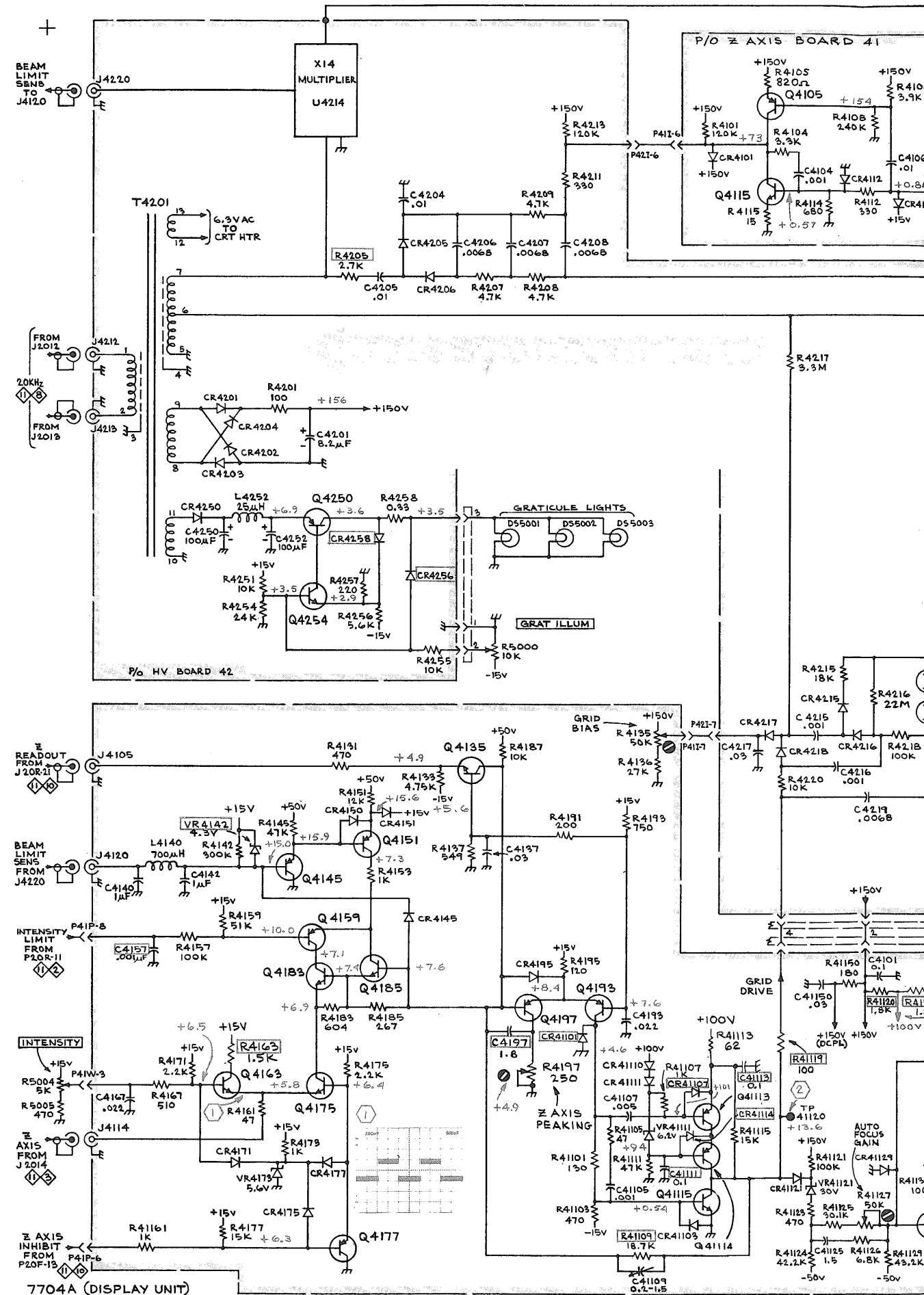

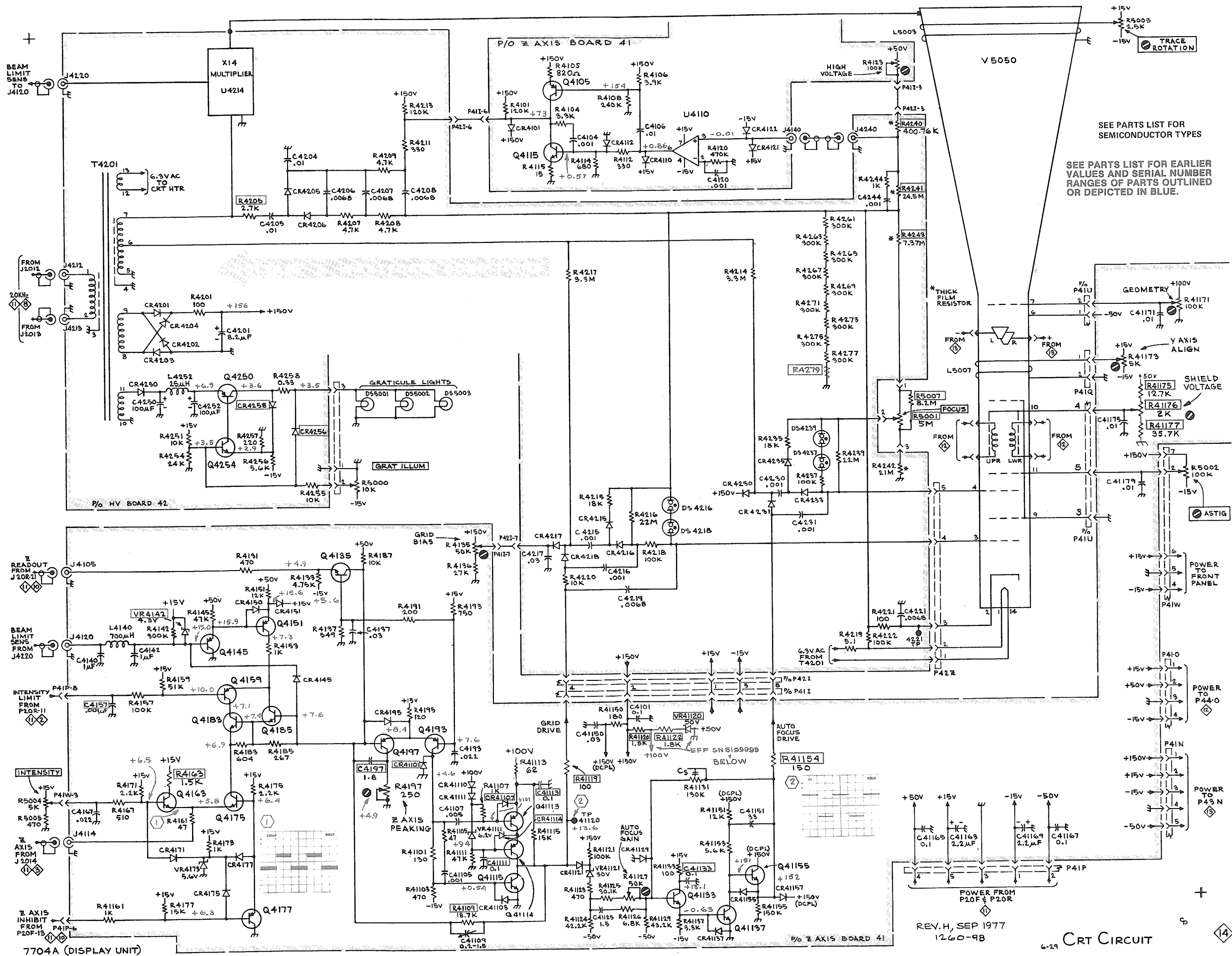

SEE PARTS LIST FOR SEMICONDUCTOR TYPES
SEE PARTS LIST FOR EARLIER VALUES AND SERIAL NUMBER RANGES OF PARTS OUTLINED OR DEPICTED IN BLUE.

REV. H, SEP 1977
1260-98

6-29 CRT CIRCUIT

ements are

1 7A13
ase, and
Differ-
set).

lifier in

er (test
em), or

orms, the
B HORIZ

GATE OUT

7704A (DISPLAY UNIT)

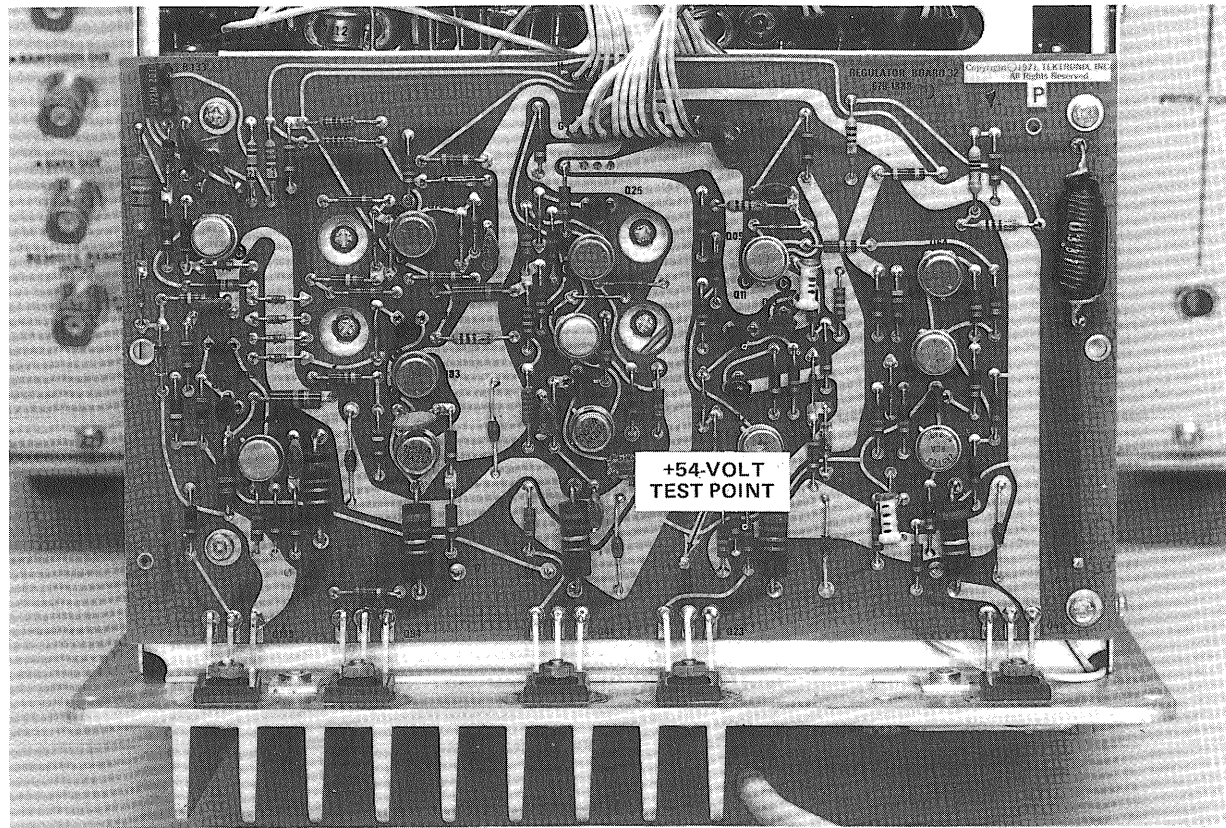

Fig. 6-26. +54-Volt test point location on A32 – Regulator board (top of power unit).

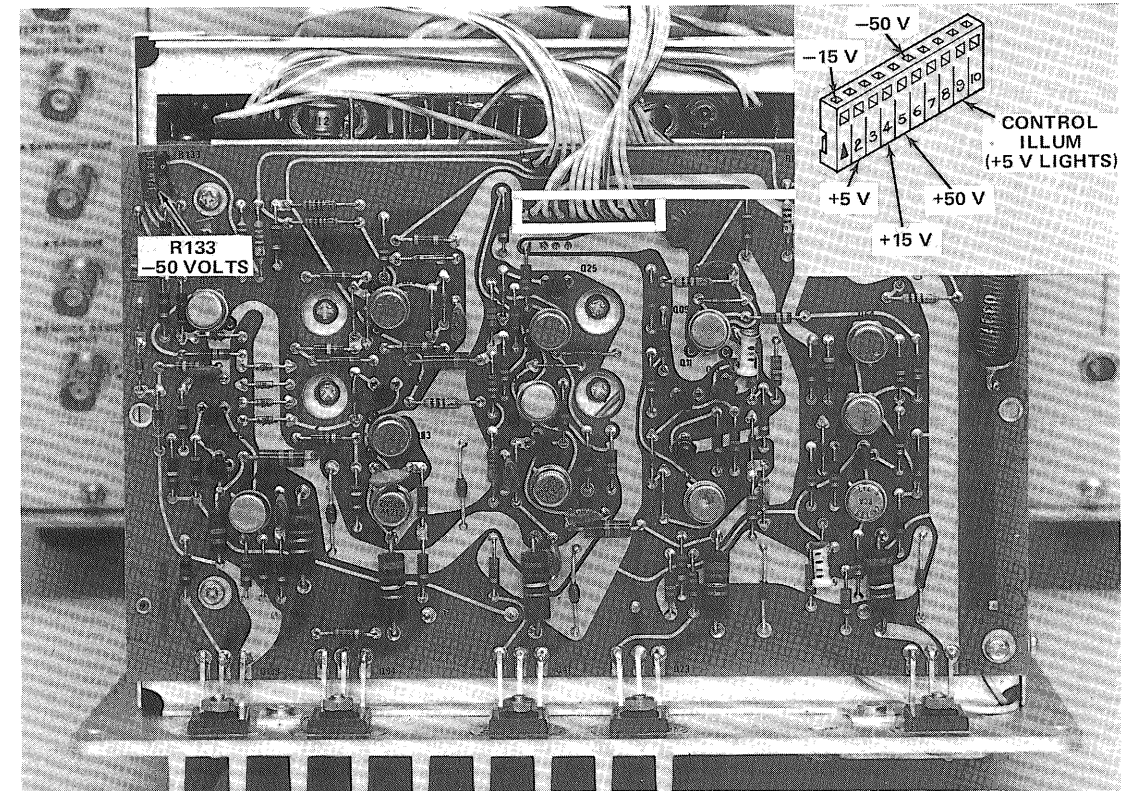

Fig. 6-28. Power-supply test points and -50 - Volt adjustment locations on A32 – Regulator board.

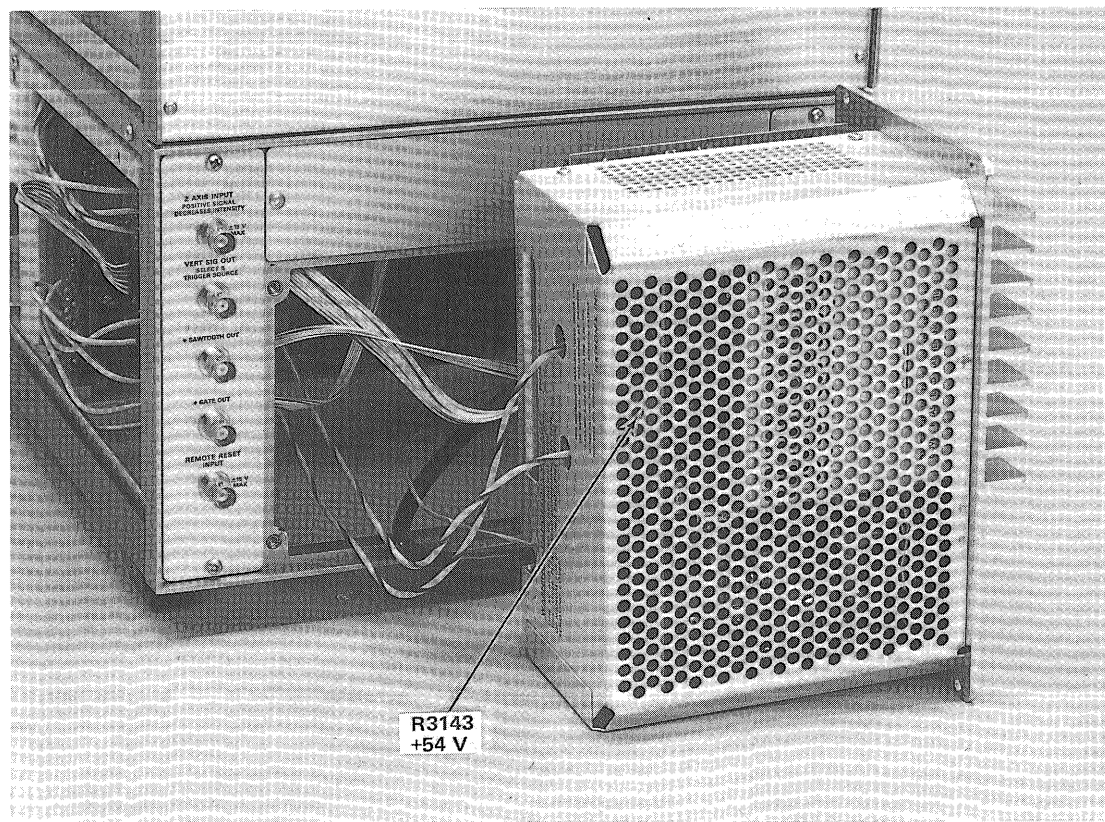

Fig. 6-27. +54-Volt adjustment, R3143, location in power unit.

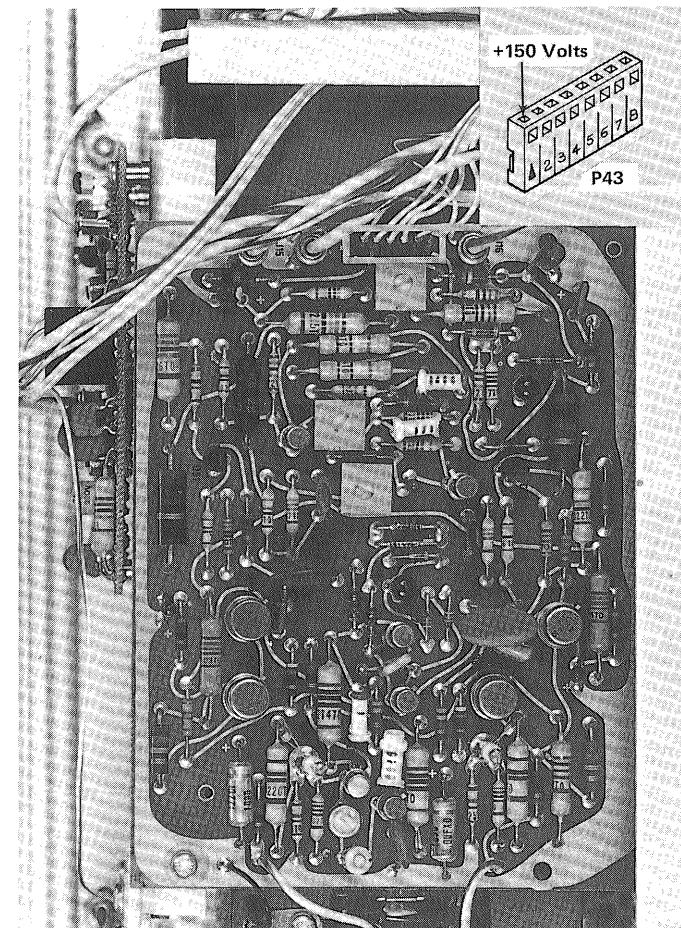

Fig. 6-29. +150-Volt test point location on A43 – Horizontal Output board.

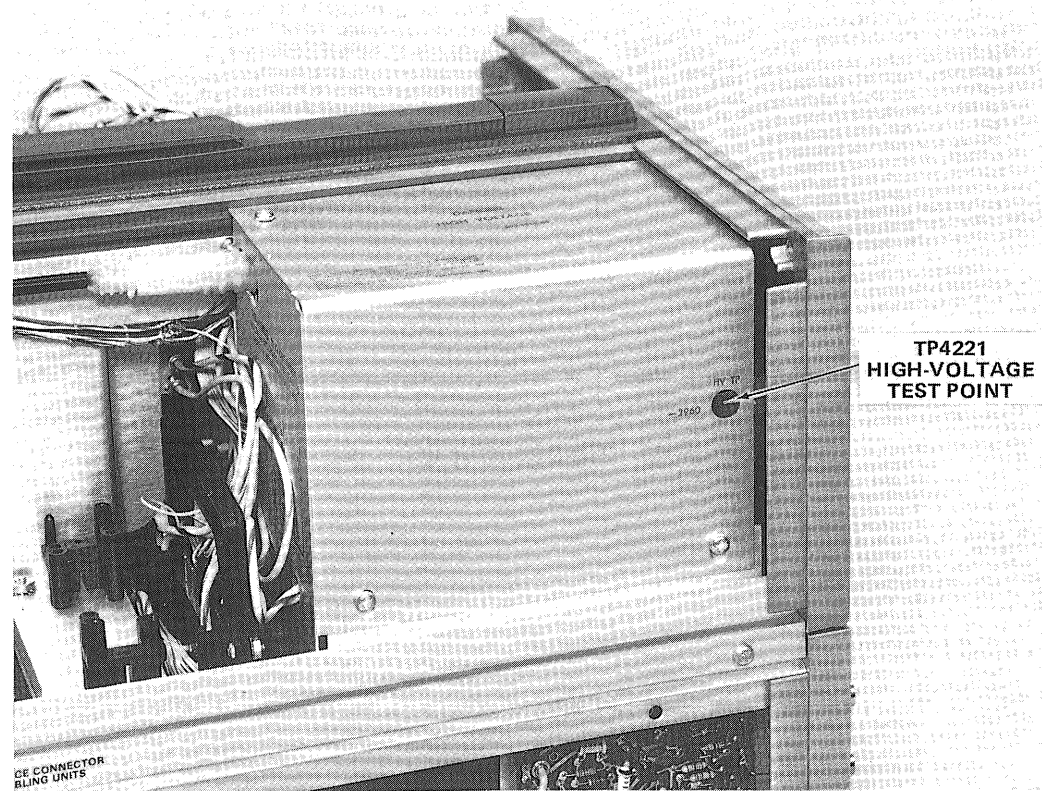

Fig. 6-30. TP4221, high-voltage test point location.

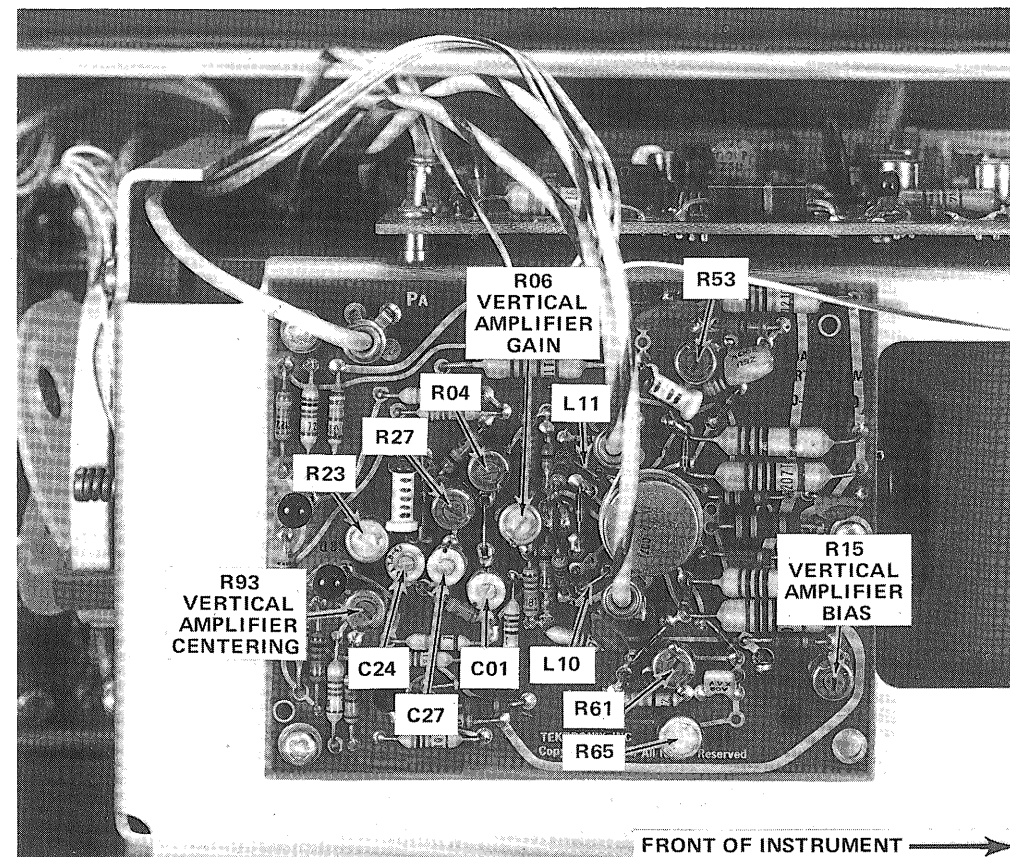

Fig. 6-32. Location of Vertical System calibration adjustments on A44 – Vertical Amplifier board.

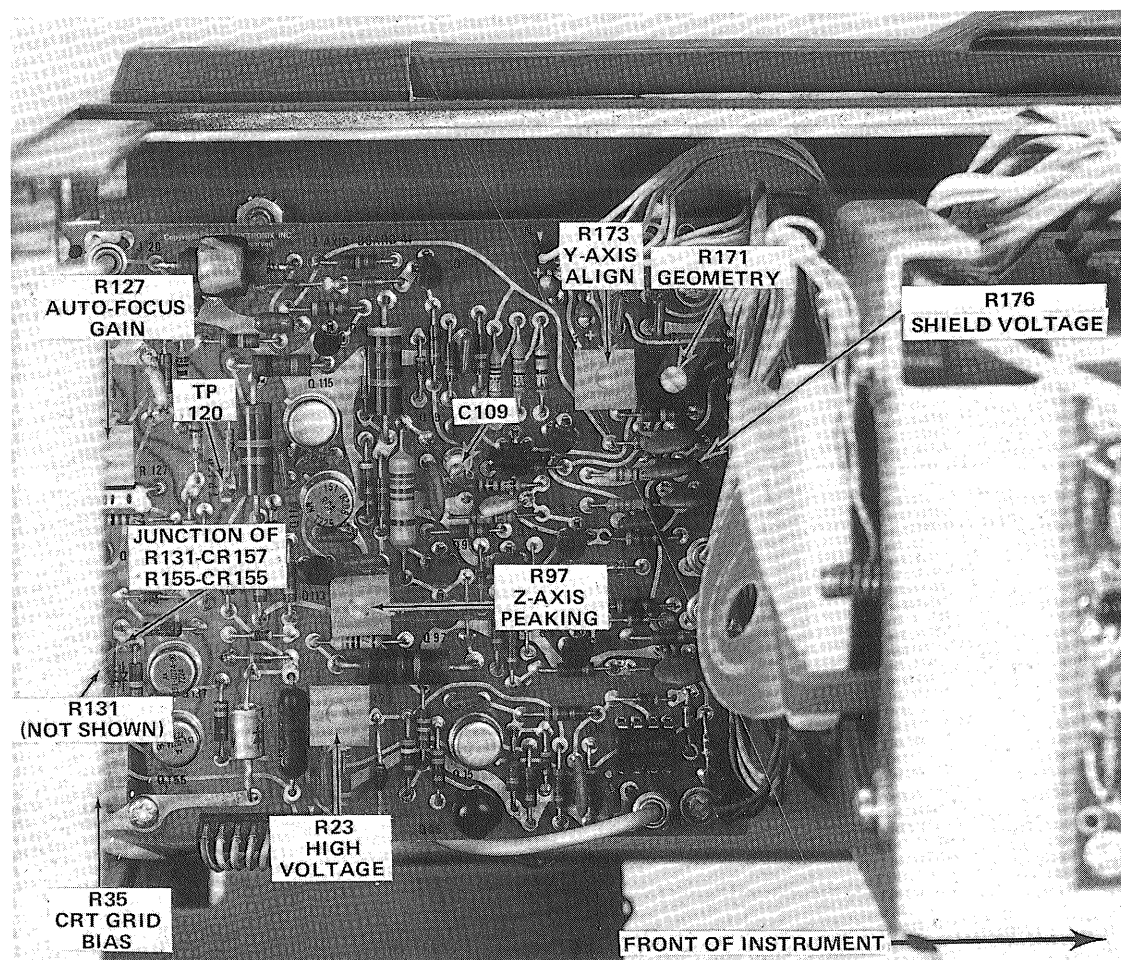

Fig. 6-31. Location of Z-Axis and Display calibration adjustments and test points on A41 – Z-Axis board.

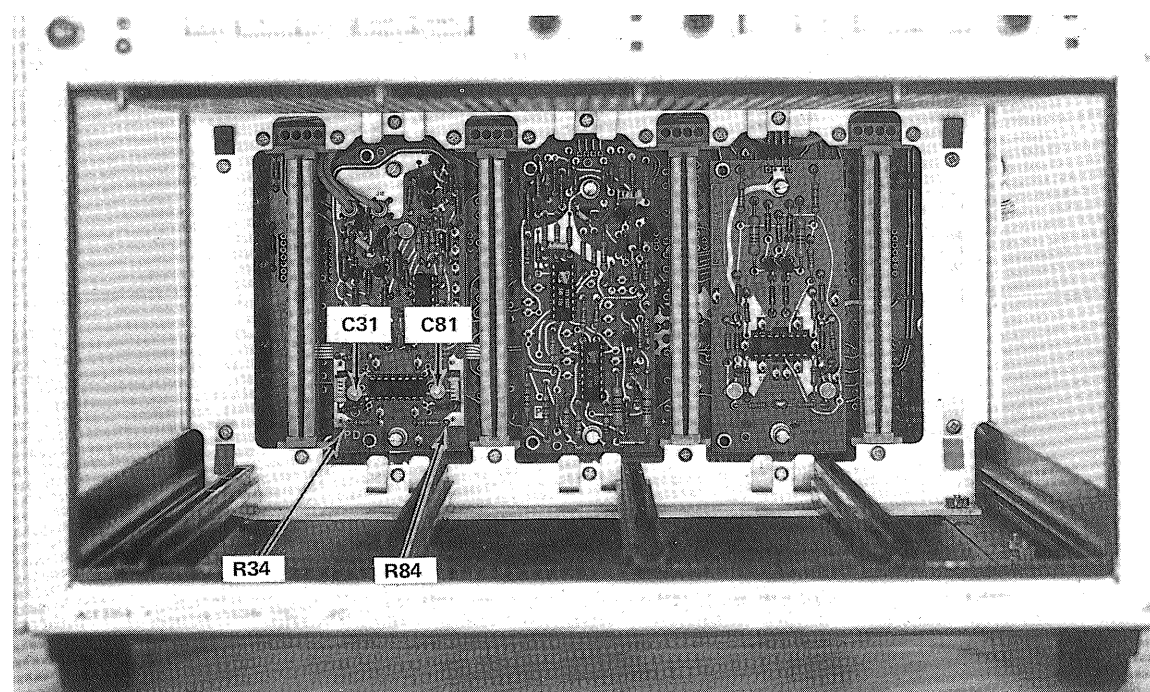

Fig. 6-33. Location of high-frequency compensation adjustments on A22 – Vertical Interface board.

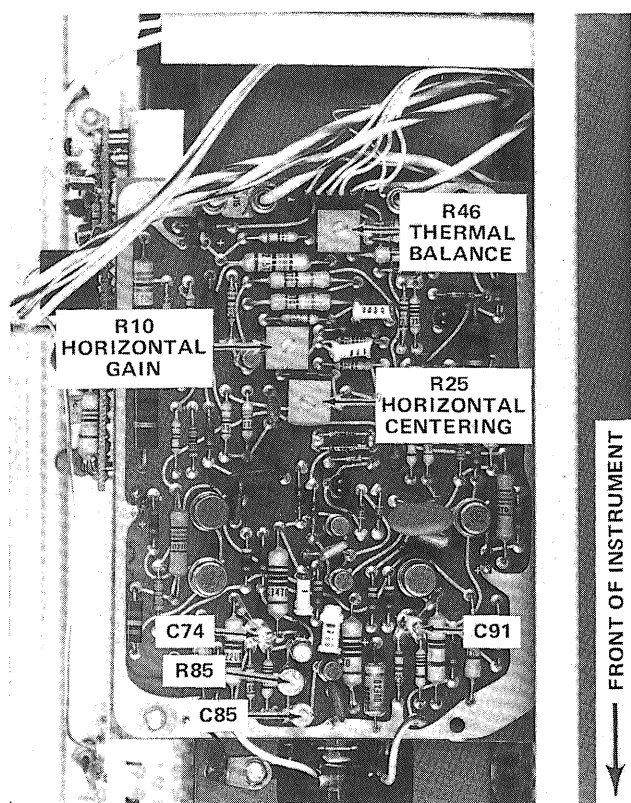

Fig. 6-34. Location of Horizontal System calibration adjustments on A43 – Horizontal Output board.

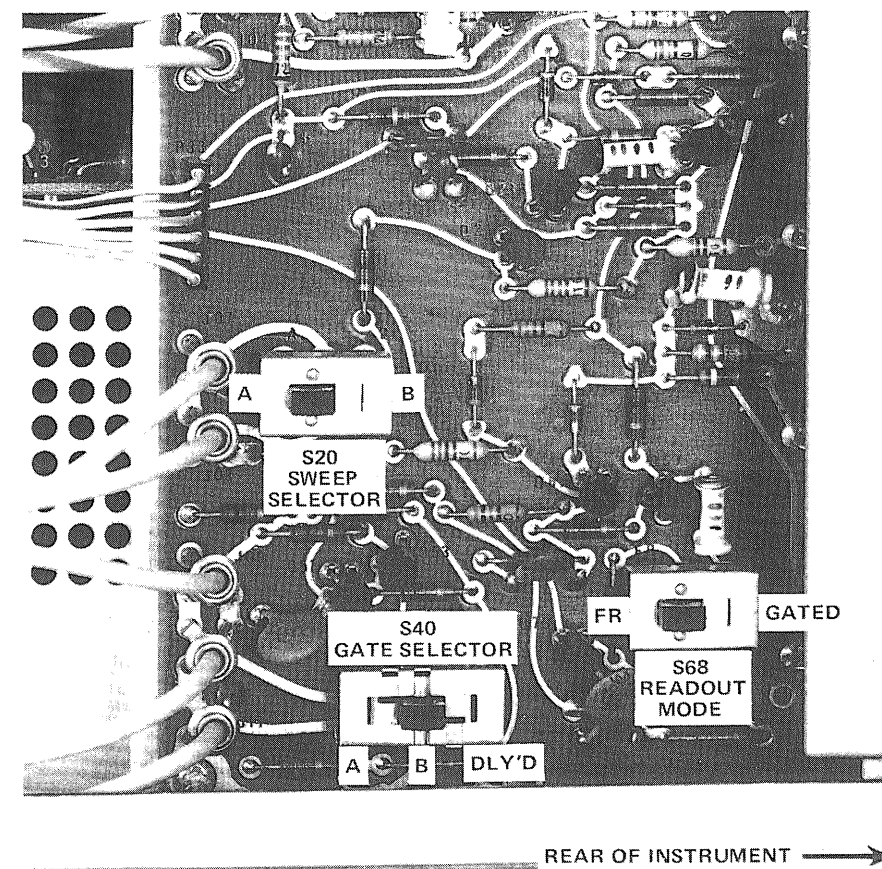

Fig. 6-36. Location of signal selector switches on A33 – Output Signals board.

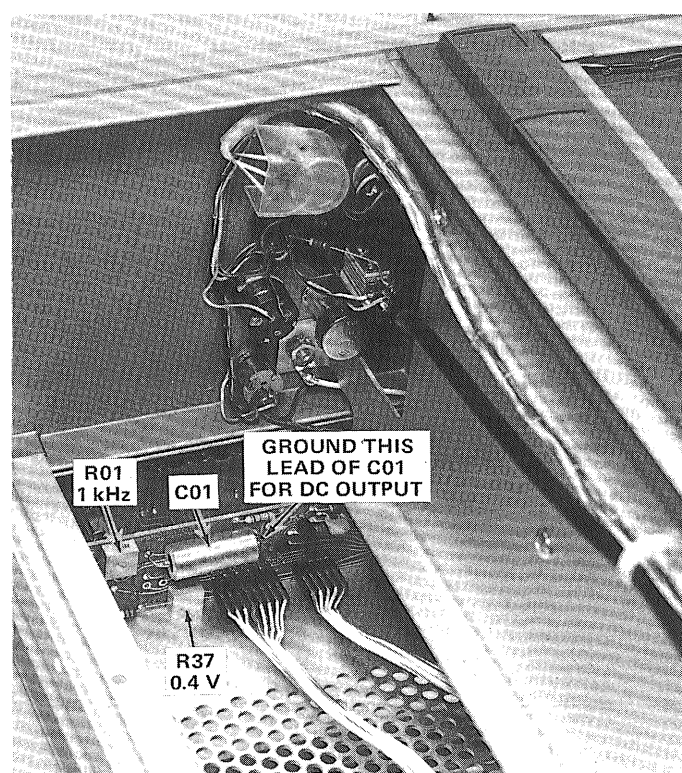

Fig. 6-35. Location of Calibrator adjustments on A10 – Calibrator board.

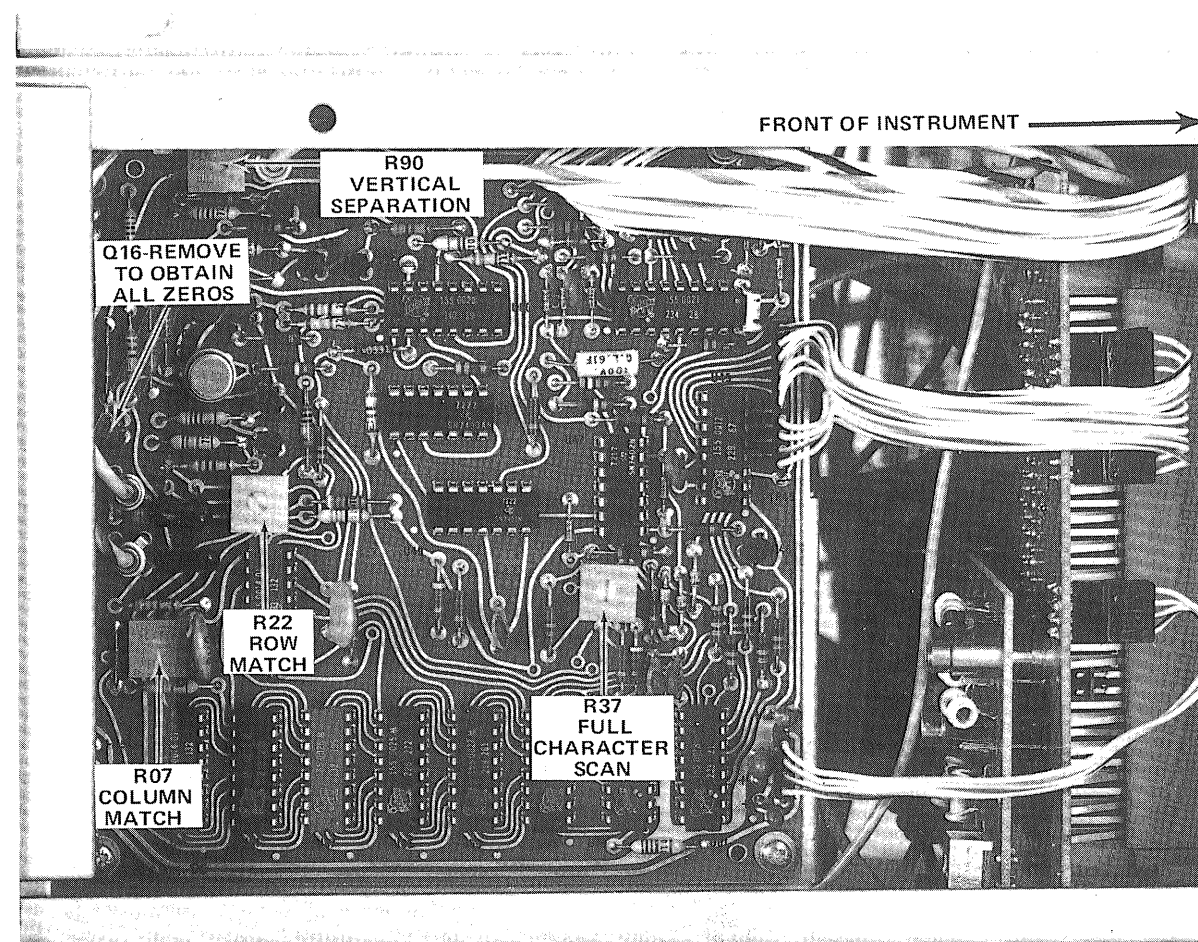
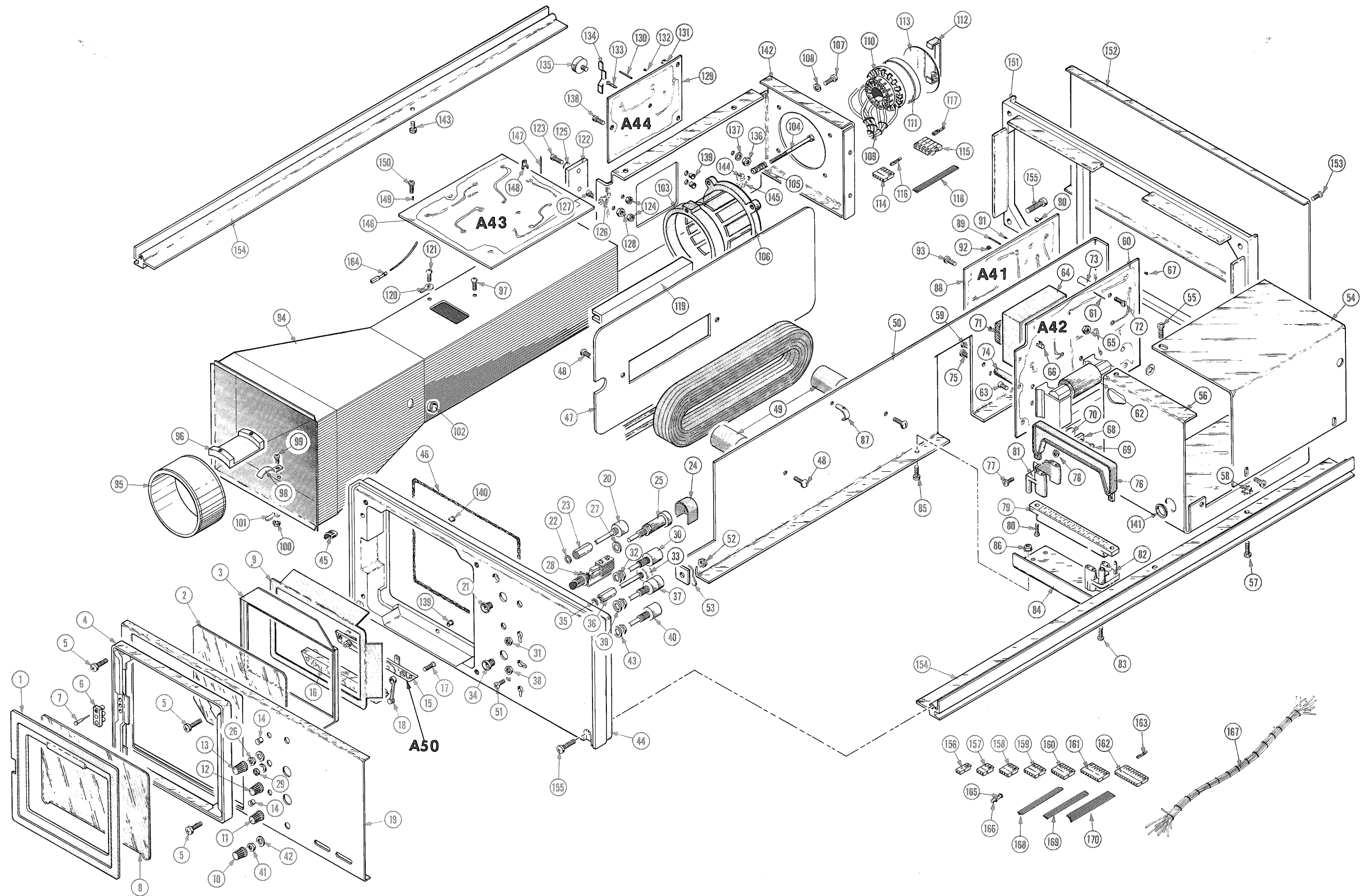

Fig. 6-37. Location of Readout System calibration adjustments on A34 – Readout board.

Replaceable Mechanical Parts—7704A

FIGURE 1 D7704 (CONT)

Fig. & Index No.	Tektronix Part No.	Serial/Model No. Eff Dscont	Qty	1	2	3	4	5	Name & Description	Mfr Code	Mfr Part Number
1-158	352-0162-00		1						CONN BODY, PL, EL:4 WIRE BLACK	80009	352-0162-00
	200-1167-00	XB101891	1						COVER, XSTR:TEMP STAB FOR 2 TO-18 CS STYLE	80009	200-1167-00
-159	352-0163-00		2						CONN BODY, PL, EL:5 WIRE BLACK	80009	352-0163-00
-160	352-0164-00		2						CONN BODY, PL, EL:6 WIRE BLACK	80009	352-0164-00
-161	352-0166-00		3						CONN BODY, PL, EL:8 WIRE BLACK	80009	352-0166-00
-162	352-0168-00		3						CONN BODY, PL, EL:10 WIRE BLACK	80009	352-0168-00
-163	131-0707-00		54						CONTACT, ELEC:0.48" L, 22-26 AWG, WIRE	22526	5999-00-396-6331
-164	195-0121-00		1						LEAD SET, CRT DE:	80009	195-0121-00
-165	210-0775-00		12						EYELET, METALLIC:0.126 OD X 0.23 INCH L, BRS	80009	210-0775-00
-166	210-0774-00		12						EYELET, METALLIC:0.152 OD X 0.245 INCH L, BRS	80009	210-0774-00
-167	179-1744-00		1						WIRING HARNESS, :FRONT PANEL	80009	179-1744-00
-168	175-0827-00		IN						WIRE, ELECTRICAL:4 WIRE RIBBON	80009	175-0827-00
-169	175-0828-00		IN						WIRE, ELECTRICAL:5 WIRE RIBBON	08261	OBD
-170	175-0831-00		IN						WIRE, ELECTRICAL:8 WIRE RIBBON	08261	OBD



+

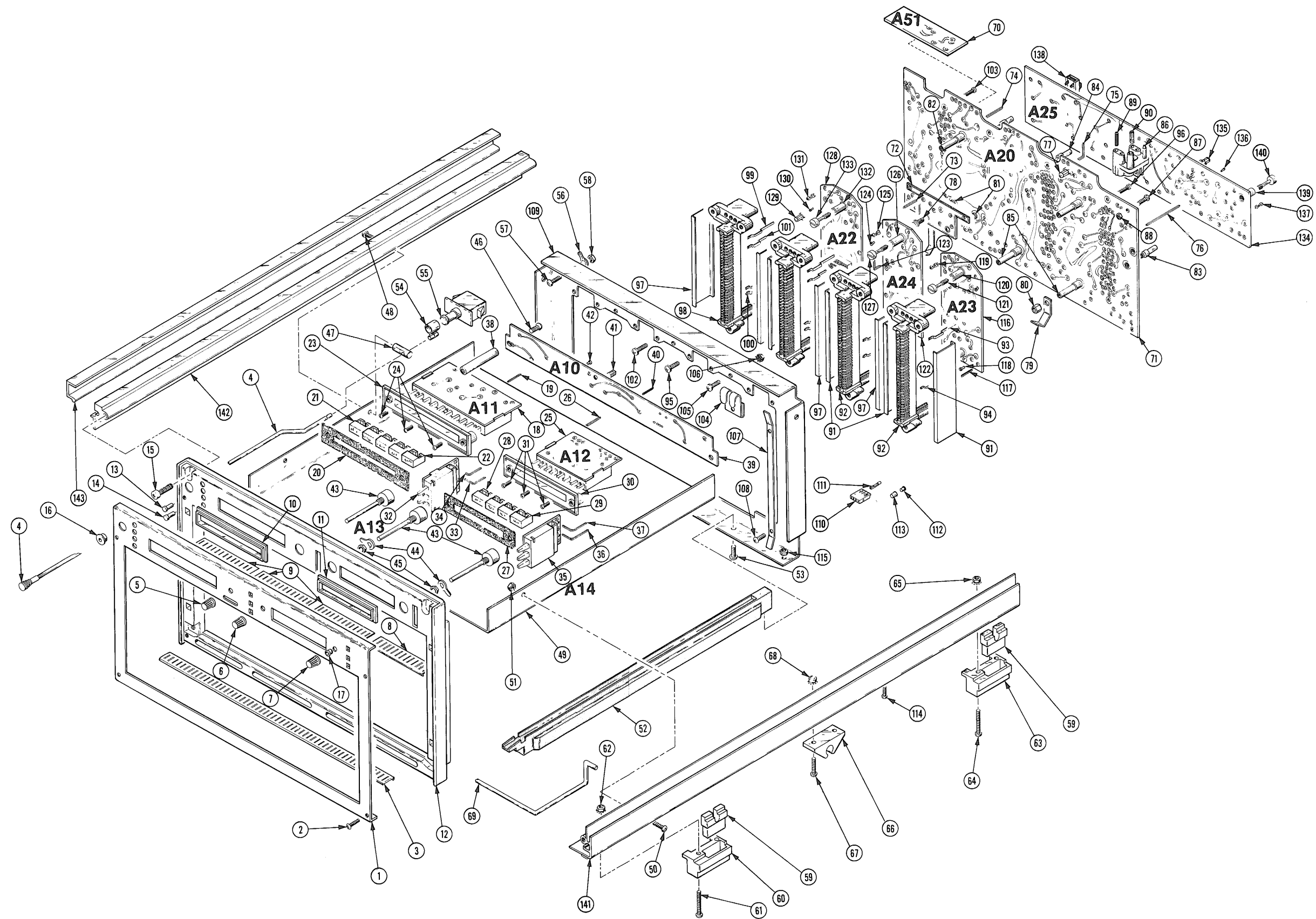

+

+

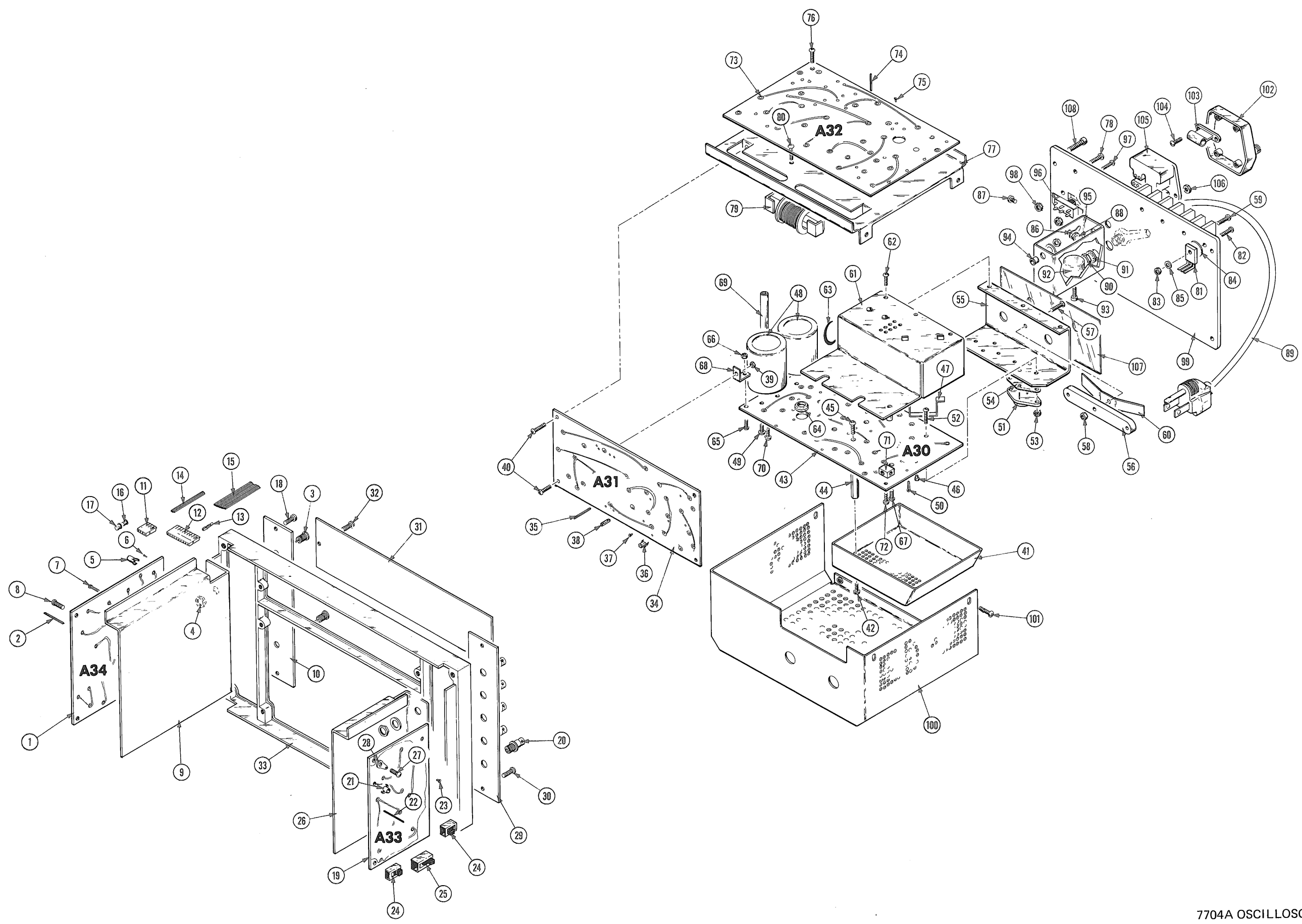

+

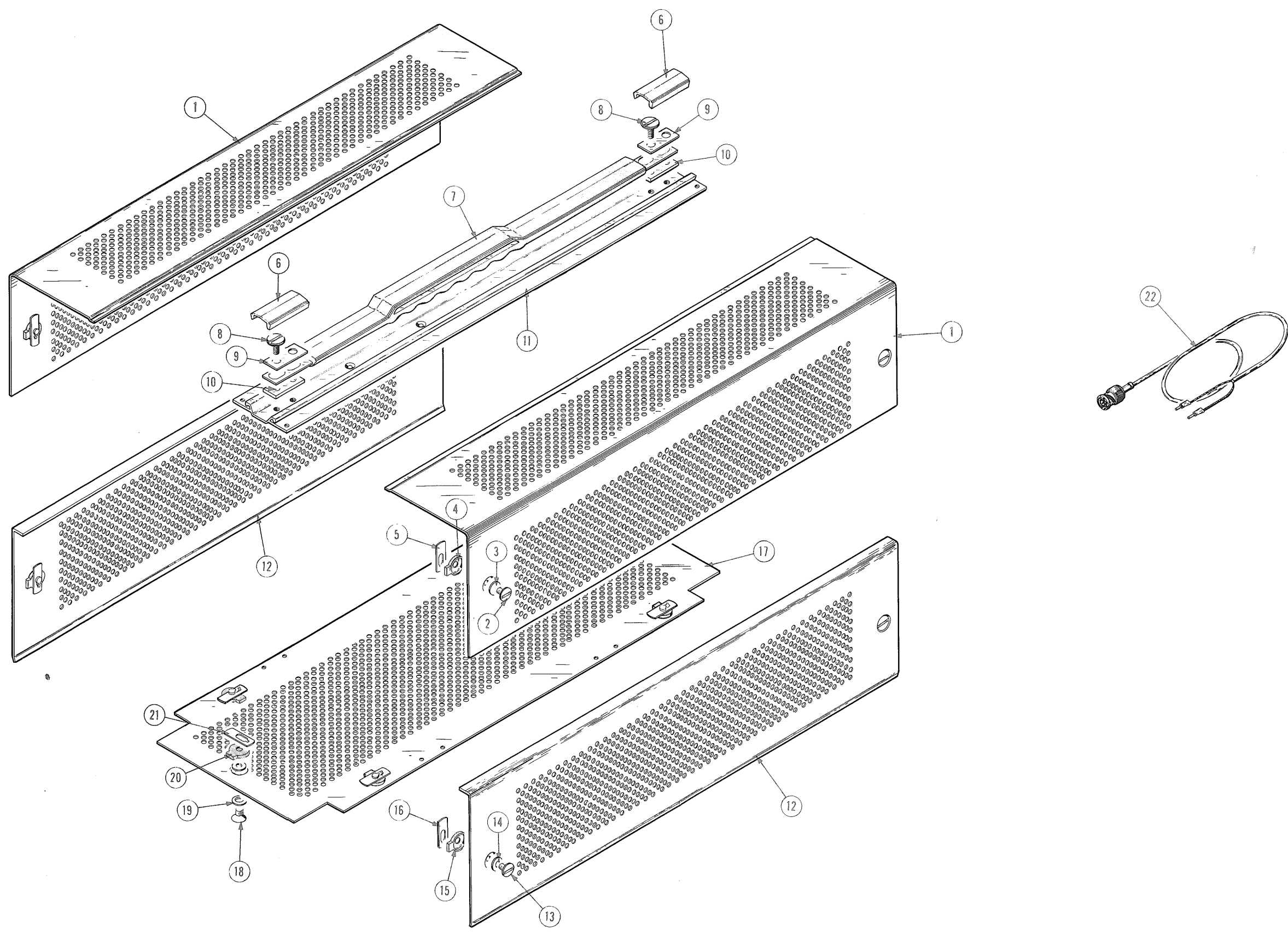

7704A OSCILLOSCOPE

Ⓐ +

REPLACEABLE PARTS FOR FACTORY INSTALLED OPTIONS

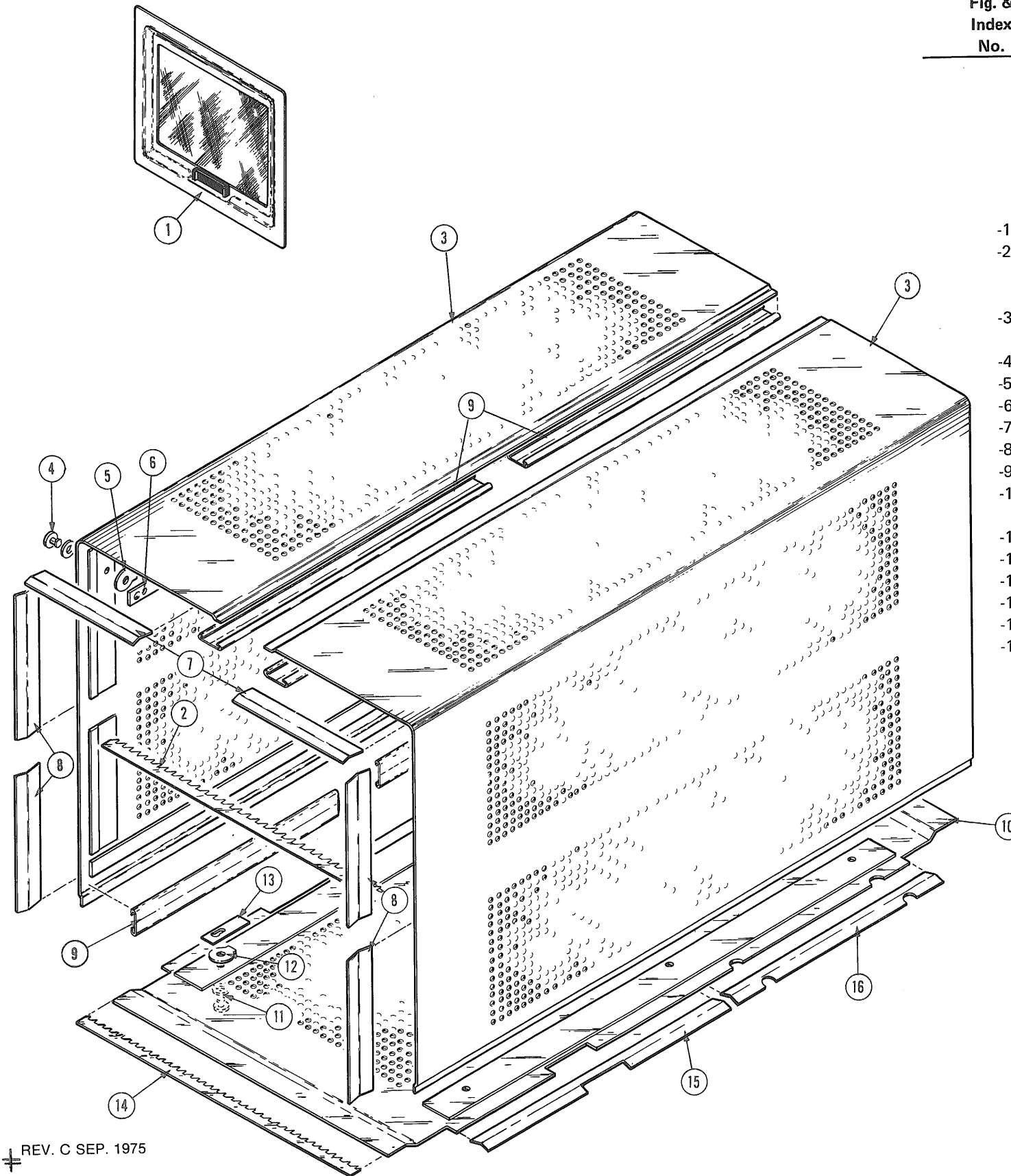

Fig. & Index No.	Tektronix Part No.	Serial/Model No. Eff	Disc	Qty					Description
				1	2	3	4	5	
OPTION 1 WITHOUT READOUT									
	200-1352-00			1					COVER, accessory cavity
OPTION 3 EMI MODIFICATION									
-1	378-0603-00			1					FILTER, mesh, CRT
-2	348-0274-00			1					SHIELDING GASKET, electronic, 24 inches long
	200-0678-00			5					COVER, BNC connector, non-shorting
	346-0045-00			5					STRAP, connector cover, plastic
-3	390-0294-00			2					CABINET SIDE
									each cabinet side includes:
-4	214-0603-02			4					PIN, securing, w/spring
-5	386-1634-00			4					PLATE, latch index
-6	386-1633-00			4					PLATE, latch locking
-7	348-0332-00			2					SHIELDING GASKET, electronic, 4.285 inches long
-8	348-0333-00			4					SHIELDING GASKET, electronic, 4.80 inches long
-9	348-0336-00			4					SHIELDING GASKET, electronic, 9.625 inches long
-10	390-0295-00			1					CABINET BOTTOM
									cabinet bottom includes:
-11	214-0603-02			6					PIN, securing, w/spring
-12	386-1634-00			6					PLATE, latch index
-13	386-1633-00			6					PLATE, latch locking
-14	348-0274-01			2					SHIELDING GASKET, electronic, 24 inches long
-15	348-0335-00			2					SHIELDING GASKET, electronic, 8.65 inches long
-16	348-0334-00			2					SHIELDING GASKET, electronic, 7.64 inches long
	016-0155-00			1					PANEL, BLANK, plug-in housing (not shown)
OPTION 7 WITHOUT SIGNAL OUTPUT									
	200-1352-00			1					COVER, accessory cavity