

Model 175A Autoranging Multimeter

Instruction Manual



Contain Operating and Servicing Information

KEITHLEY

WARRANTY

Keithley Instruments, Inc. warrants this product to be free from defects in material and workmanship for a period of 1 year from date of shipment.

Keithley Instruments, Inc. warrants the following items for 90 days from the date of shipment: probes, cables, rechargeable batteries, diskettes, and documentation.

During the warranty period, we will, at our option, either repair or replace any product that proves to be defective.

To exercise this warranty, write or call your local Keithley representative, or contact Keithley headquarters in Cleveland, Ohio. You will be given prompt assistance and return instructions. Send the product, transportation prepaid, to the indicated service facility. Repairs will be made and the product returned, transportation prepaid. Repaired or replaced products are warranted for the balance of the original warranty period, or at least 90 days.

LIMITATION OF WARRANTY

This warranty does not apply to defects resulting from product modification without Keithley's express written consent, or misuse of any product or part. This warranty also does not apply to fuses, software, non-rechargeable batteries, damage from battery leakage, or problems arising from normal wear or failure to follow instructions.

THIS WARRANTY IS IN LIEU OF ALL OTHER WARRANTIES, EXPRESSED OR IMPLIED, INCLUDING ANY IMPLIED WARRANTY OF MERCHANTABILITY OR FITNESS FOR A PARTICULAR USE. THE REMEDIES PROVIDED HEREIN ARE BUYER'S SOLE AND EXCLUSIVE REMEDIES.

NEITHER KEITHLEY INSTRUMENTS, INC. NOR ANY OF ITS EMPLOYEES SHALL BE LIABLE FOR ANY DIRECT, INDIRECT, SPECIAL, INCIDENTAL OR CONSEQUENTIAL DAMAGES ARISING OUT OF THE USE OF ITS INSTRUMENTS AND SOFTWARE EVEN IF KEITHLEY INSTRUMENTS, INC., HAS BEEN ADVISED IN ADVANCE OF THE POSSIBILITY OF SUCH DAMAGES. SUCH EXCLUDED DAMAGES SHALL INCLUDE, BUT ARE NOT LIMITED TO: COSTS OF REMOVAL AND INSTALLATION, LOSSES SUSTAINED AS THE RESULT OF INJURY TO ANY PERSON, OR DAMAGE TO PROPERTY.



Keithley Instruments, Inc. • 28775 Aurora Road • Cleveland, OH 44139 • 440-248-0400 • Fax: 440-248-6168 • <http://www.keithley.com>

BELGIUM:	Keithley Instruments B.V.	Bergensesteenweg 709 • B-1600 Sint-Pieters-Leeuw • 02/363 00 40 • Fax: 02/363 00 64
CHINA:	Keithley Instruments China	Yuan Chen Xin Building, Room 705 • 12 Yumin Road, Dewai, Madian • Beijing 100029 • 8610-62022886 • Fax: 8610-62022892
FRANCE:	Keithley Instruments Sarl	B.P. 60 • 3, allée des Garays • 91122 Palaiseau Cédex • 01 64 53 20 20 • Fax: 01 60 11 77 26
GERMANY:	Keithley Instruments GmbH	Landsberger Strasse 65 • D-82110 Germering • 089/84 93 07-40 • Fax: 089/84 93 07-34
GREAT BRITAIN:	Keithley Instruments Ltd	The Minster • 58 Portman Road • Reading, Berkshire RG30 1EA • 0118-9 57 56 66 • Fax: 0118-9 59 64 69
INDIA:	Keithley Instruments GmbH	Flat 2B, WILOCRISIA • 14, Rest House Crescent • Bangalore 560 001 • 91-80-509-1320/21 • Fax: 91-80-509-1322
ITALY:	Keithley Instruments s.r.l.	Viale S. Gimignano, 38 • 20146 Milano • 02/48 30 30 08 • Fax: 02/48 30 22 74
NETHERLANDS:	Keithley Instruments B.V.	Postbus 559 • 4200 AN Gorinchem • 0183-635333 • Fax: 0183-630821
SWITZERLAND:	Keithley Instruments SA	Kriesbachstrasse 4 • 8600 Dübendorf • 01-821 94 44 • Fax: 01-820 30 81
TAIWAN:	Keithley Instruments Taiwan	1 Fl. 85 Po Ai Street • Hsinchu, Taiwan, R.O.C. • 886-3572-9077 • Fax: 886-3572-9031

Model 175A Autorange Multimeter Instruction Manual

© 1990, Keithley Instruments, Inc.
Test Instrumentation Group
All rights reserved.
Cleveland, Ohio, U.S.A.
January 1990, First Printing
Document Number: 175A-901-01 Rev. A

All Keithley products are trademarks or registered trademarks of Keithley Instruments, Inc.

Other brand and product names are trademarks or registered trademarks of their respective holders.

SAFETY PRECAUTIONS

The following safety precautions should be observed before operating the Model 175A.

This instrument is intended for use by qualified personnel who recognize shock hazards and are familiar with the safety precautions required to avoid possible injury. Read over the manual carefully before operating this instrument.

Exercise extreme caution when a shock hazard is present at the instrument's input. The American National Standards Institute (ANSI) states that a shock hazard exists when voltage levels greater than 30V rms or 42.4V peak are present. **A good safety practice is to expect that a hazardous voltage is present in any unknown circuit before measuring.**

Inspect the test leads for possible wear, cracks or breaks before each use. If any defects are found, replace the test leads.

For optimum safety do not touch the test leads or the instrument while power is applied to the circuit under test. Turn the power off and discharge all capacitors before connecting or disconnecting the instrument.

Do not touch any object that could provide a current path to the common side of the circuit under test or power line (earth) ground. Always make measurements with dry hands while standing on a dry, insulated surface, capable of withstanding the voltage being measured.

Exercise extreme safety when testing high energy power circuits (AC line or mains, etc.). Refer to High Energy Circuit Safety Precautions found in paragraph 2.2.

Do not exceed the instrument's maximum allowable input as defined in the specifications and operation section.

Instrumentation and accessories should not be connected to humans.

Model 175A Autoranging DMM

DC VOLTS

RANGE	RESOLUTION	ACCURACY (1 Year) 18°-28°C	
		±(%rdg + counts)	
200 mV	10 µV	0.03 + 2	
2 V	100 µV	0.03 + 1	
20 V	1 mV	0.03 + 1	
200 V	10 mV	0.03 + 1	
1000 V	100 mV	0.03 + 1	

INPUT RESISTANCE: 11MΩ on 200mV, 2V, and 20V ranges. 10MΩ on 200V and 1000V ranges. (>1000MΩ on the 200mV and 2V ranges with all function buttons in the out position.)

NORMAL MODE REJECTION RATIO: >60dB at 50Hz, 60Hz ±0.15%.

MAXIMUM ALLOWABLE INPUT: 1000V DC or peak AC (<10s per minute on 200mV and 2V ranges; 300V rms continuous).

SETTLING TIME: 1 second to within 1 count of final reading on range.

dB MODE (ref: 600Ω): Accuracy: ±(0.02dB + 1 count) above -78dBm.

RESOLUTION: 0.01dB above 5% of range.

TRMS AC VOLTS

RANGE	ACCURACY (1 Year)* 18°-28°C ±(%rdg + counts)				
	20Hz-50Hz	50Hz-10kHz	10kHz-20kHz	20kHz-50kHz	50kHz-100kHz
2V-750V	1 + 20	0.5 + 20	1 + 40	2.5 + 75	5 + 200
200 mV	1 + 20	0.5 + 20	1.5 + 40	8 + 75	—

*Above 1800 counts.

MAXIMUM ALLOWABLE INPUT: 750V rms, 1000V peak (<10 seconds per minute on 200mV range; 300V rms continuous). 107V•Hz maximum.

3dB BANDWIDTH: 300kHz typical.

INPUT IMPEDANCE: 10MΩ paralleled by <75pF on 20V, 200V, and 1000V ranges. 11MΩ on 200mV and 2V ranges. Capacitively coupled.

SETTLING TIME: 2 seconds to within 15 counts of final reading on range.

dB MODE (ref: 600Ω):

RANGE	INPUT	ACCURACY (±dBm)			
		20Hz-10kHz	10kHz-20kHz	20kHz-50kHz	50kHz-100kHz
2V-750V	200 mV to 750 V (-12 to +59.8dBm)	0.2	0.26	0.56	1.2
200 mV	20 mV to 200 mV (-32 to -12 dBm)	0.2	0.3	1	—
	2 mV to 20 mV (-52 to -32 dBm)	2	3	—	—
	1 mV to 2 mV (-58 to -52 dBm)	2*	—	—	—

RESOLUTION: 0.01dB above 5% of range. *Up to 1kHz.

DC AMPS

RANGE	RESOLUTION	MAXIMUM VOLTAGE BURDEN	ACCURACY (1 Year) 18°-28°C	
			±(%rdg + counts)	
200 µA	10 nA	0.3 V	0.15 + 2	
2 mA	100 nA	0.3 V	0.15 + 2	
20 mA	1 µA	0.3 V	0.15 + 2	
200 mA	10 µA	0.3 V	0.2 + 2	
2000 mA	100 µA	0.8 V	0.2 + 2	
10 A	1 mA	0.3 V	0.5 + 2*	

*Above 5A derate 0.15% rdg per amp for self-heating.

OVERLOAD PROTECTION: mA Input: 2A fuse (250V), externally accessible. 10A Input: 20A for 15s, unfused.

SETTLING TIME: 1 second to within 1 count of final reading.

TRMS AC AMPS

RANGE	MAXIMUM VOLTAGE BURDEN	ACCURACY (1 Year)* 18°-28°C		
		±(%rdg+counts)		
		20Hz-50Hz	50Hz-10kHz	10kHz-30kHz
200µA-20mA	0.3 V	1 + 20	0.8 + 20	2 + 50
200 mA	0.3 V	1 + 20	0.8 + 20	—
2000 mA	0.8 V	1 + 20	0.8 + 20	—
10 A	0.3 V	1.5 + 20**	1 + 20**	—

*Above 1800 counts. **1kHz max. Above 5A derate 0.15% rdg./amp for self-heating.

SETTLING TIME: 2 seconds to within 15 counts of final reading.

OHMS

RANGE	RESOLUTION	ACCURACY (1 Year) 18°-28°C		MAX. VOLTAGE ACROSS UNKNOWN ON RANGE
		±(%rdg + counts)		
200 Ω	10 mΩ	0.05 + 2*		0.2 V
2 kΩ →	100 mΩ	0.05 + 1		2.0 V
20 kΩ	1 Ω	0.05 + 2		0.2 V
200 kΩ →	10 Ω	0.05 + 1		2.0 V
2MΩ **	100 Ω	0.05 + 2		0.2 V
20MΩ **	1 kΩ	0.2 + 1		2.0 V
200MΩ **	100 kΩ	2.0 + 1		2.0 V

*When properly zeroed. **Appropriate range selected automatically.

MAXIMUM ALLOWABLE INPUT: 450V DC or peak AC.

OPEN-CIRCUIT VOLTAGE: +5V.

DIODE TEST: Display reads junction voltage up to 2V. Test current: 0.7mA nominal.

SETTLING TIME: 2 seconds to within 1 count of final reading on range.

IEEE-488 BUS IMPLEMENTATION (Model 1753A Option)

MULTILINE COMMANDS: DCL, SDC, GET, GTL, UNT, UNL, SPE, SPD.

UNILINE COMMANDS: IFC, REN, EOI, SRQ, ATN.

INTERFACE FUNCTIONS: SH1, AH1, T5, TE0, L4, LE0, SR1, RL2, PP0, DC1, DT1, C0, E1.

PROGRAMMABLE PARAMETERS: Range, REL, dB, EOI, Trigger, Calibration, SRQ Status, Output Format, Terminator.

GENERAL

DISPLAY: 4½-digit LCD with backlight (switch selectable), 0.5 in. height; polarity, function, range, and status indication.

RANGING: Auto or manual on DC volts, AC volts, ohms; manual on AC amps, DC amps.

AUTORANGING TIME: 300ms per range.

RELATIVE: Pushbutton allows zeroing of on range readings. Allows readings to be made with respect to baseline value. Front panel annunciator indicates REL mode.

DATA LOGGER and MIN/MAX: 100 reading storage capacity; records data at one of six selectable rates from 3 readings/second to 1 reading/hour. Also detects and stores maximum and minimum readings continuously in data logger mode.

CONVERSION RATE: 3 readings per second.

OVERRANGE INDICATION: "OL" displayed.

CREST FACTOR (ratio of peak value to rms value), AC FUNCTIONS: 3.

MAXIMUM COMMON MODE VOLTAGE: 500V peak.

COMMON MODE REJECTION RATIO (1kΩ unbalance): >120dB at DC, 50Hz, 60Hz ±0.15%. >60dB in AC volts.

TEMPERATURE COEFFICIENT (0°-18°C & 28°-50°C): ±(0.1 × applicable accuracy specification)/°C except ±(0.07%+2)/°C for 50Hz-10kHz in AC volts.

ENVIRONMENT: Operating: 0° to 50°C; <80% relative humidity up to 35°C; linearly derate 3% RH/°C, 35° to 50°C. **Storage:** -40° to +70°C.

WARM-UP: 1 hour to rated accuracy.

POWER: 105-125V or 210-250V (external switch selected), 90-110V available; 50-60Hz, 12VA. Removable power cord. Optional 6-hour battery pack, Model 1758.

DIMENSIONS, WEIGHT: 89mm high × 235mm wide × 275mm deep (3½ in. × 9¼ in. × 10¾ in.). Net weight 1.8kg (3 lbs., 14 oz.).

ACCESSORIES SUPPLIED: Model 1751 Shrouded Test Leads, instruction manual.

Specifications subject to change without notice.

Table of Contents

SECTION 1 — General Information

1.1	INTRODUCTION	1-1
1.2	FEATURES	1-1
1.3	WARRANTY INFORMATION	1-1
1.4	MANUAL ADDENDA	1-1
1.5	SAFETY SYMBOLS AND TERMS	1-2
1.6	SPECIFICATIONS	1-2
1.7	INSPECTION	1-2
1.8	USING THE MODEL 175A MANUAL	1-2
1.9	GETTING STARTED	1-2
1.10	ACCESSORIES	1-3

SECTION 2 — Bench Operation

2.1	INTRODUCTION	2-1
2.2	HIGH ENERGY CIRCUIT SAFETY PRECAUTIONS	2-1
2.3	PREPARATION FOR USE	2-2
2.3.1	Line Power	2-2
2.3.2	Battery Pack Power	2-2
2.3.3	Battery Charging	2-2
2.4	FRONT PANEL FAMILIARIZATION	2-2
2.4.1	Display	2-2
2.4.2	Front Panel Controls	2-3
2.4.3	Input Terminals	2-4
2.4.4	Current Fuse Replacement	2-4
2.5	ERROR MESSAGES	2-4
2.6	OPERATING CONDITIONS	2-4
2.6.1	Environmental Conditions	2-4
2.6.2	Maximum Allowable Inputs	2-5
2.7	BASIC BENCH MEASUREMENTS	2-5
2.7.1	Power-Up	2-5
2.7.2	Relative Mode	2-6
2.7.3	Dc Voltage Measurements	2-6
2.7.4	TRMS AC Voltage Measurements	2-6
2.7.5	Resistance Measurements	2-7
2.7.6	Current Measurements (DC or TRMS AC)	2-8
2.7.7	AC plus DC Measurements	2-9
2.7.8	dB Measurements	2-10
2.7.9	dB Measurement Considerations and Applications	2-12
2.7.10	MIN/MAX and 100-Point Data Logger Operation	2-12
2.7.11	Diode Test	2-13
2.8	TRMS CONSIDERATIONS	2-13
2.8.1	TRMS Measurement Comparison	2-13

2.8.2	AC Voltage Offset	2-14
2.8.3	Crest Factor	2-14
2.8.4	Extended Frequency Response	2-14

SECTION 3 — Performance Verification

3.1	INTRODUCTION	3-1
3.2	ENVIRONMENTAL CONDITIONS	3-1
3.3	INITIAL CONDITIONS	3-1
3.4	RECOMMENDED TEST EQUIPMENT	3-1
3.5	VERIFICATION PROCEDURE	3-1
3.5.1	DC Voltage Verification	3-2
3.5.2	AC Voltage Verification	3-2
3.5.3	Resistance Verification	3-3
3.5.4	DC Current Verification	3-3
3.5.5	AC Current Verification	3-3

SECTION 4 — Principles of Operation

4.1	INTRODUCTION	4-1
4.2	OVERALL FUNCTIONAL DESCRIPTION	4-1
4.3	ANALOG CIRCUITRY	4-1
4.3.1	Multiplexer	4-1
4.3.2	Input Buffer Amplifier	4-2
4.3.3	-2V Reference Source	4-2
4.3.4	A/D Converter	4-2
4.3.5	Input Signal Conditioning	4-4
4.3.6	AC Converter	4-5
4.4	DIGITAL CIRCUITRY	4-6
4.4.1	Microcomputer	4-6
4.4.2	Address Decoding	4-6
4.4.3	PIA	4-6
4.4.4	Display Board	4-6
4.4.5	Display Backlight	4-7
4.5	DIGITAL CALIBRATION	4-7
4.6	POWER SUPPLY	4-7
4.7	MODEL 1758 BATTERY OPTION	4-7

SECTION 5 — Maintenance

5.1	INTRODUCTION	5-1
5.2	DISASSEMBLY INSTRUCTIONS	5-1
5.3	MODEL 1758 BATTERY PACK INSTALLATION	5-4
5.4	LINE VOLTAGE SELECTION	5-4
5.5	FUSE REPLACEMENT	5-5
5.5.1	Current Fuse	5-5
5.5.2	Line Fuse	5-5

5.6	CALIBRATION	5-5
5.6.1	Recommended Calibration Equipment	5-6
5.6.2	Environmental Conditions	5-6
5.6.3	Warm-Up Period	5-6
5.6.4	CALIBRATION Switch	5-6
5.6.5	DC Voltage Calibration From Front Panel	5-7
5.6.6	AC Voltage Calibration From Front Panel	5-7
5.6.7	Resistance Calibration From Front Panel	5-7
5.6.8	Frequency Composition	5-8
5.6.9	Calibration Storage	5-8
5.6.10	IEEE-488 Calibration	5-8
5.7	TROUBLESHOOTING	5-9
5.7.1	Recommended Test Equipment	5-9
5.7.2	Self Diagnostic Program	5-10
5.7.3	Power Supply and Battery Pack (Model 1758) Checks	5-14
5.7.4	A/D Converter and Display	5-14
5.7.5	Signal Conditioning	5-14
5.8	SPECIAL HANDLING OF STATIC SENSITIVE DEVICES	5-14

SECTION 6 — Replaceable Parts

6.1	INTRODUCTION	6-1
6.2	PARTS LIST	6-1
6.3	ORDERING INFORMATION	6-1
6.4	FACTORY SERVICE	6-1
6.5	SCHEMATIC DIAGRAMS AND COMPONENT LOCATION DRAWINGS	6-1

List of Illustrations

SECTION 2 — Bench Operation

Figure 2-1	Model 175A Front Panel	2-3
Figure 2-2	DC Voltage Measurements	2-7
Figure 2-3	AC Voltage Measurements	2-7
Figure 2-4	Resistance Measurements	2-8
Figure 2-5	Current Measurements between 2000mA and 20A	2-9
Figure 2-6	Current Measurements up to 2000mA	2-9
Figure 2-7	Model 175A Typical ACV Frequency Response	2-16

SECTION 4 — Principles of Operation

Figure 4-1	Simplified Block Diagram	4-2
Figure 4-2	Simplified Schematic of the Multiplexer	4-3
Figure 4-3	Simplified Schematic of the Input Buffer Amplifier	4-3
Figure 4-4	Simplified Schematic of the A/D Converter	4-4
Figure 4-5	Resistance Measurements – Ratiometric Techniques	4-5
Figure 4-6	Simplified Schematics of Ohms Circuitry	4-6

SECTION 5 — Maintenance

Figure 5-1	Model 175A Exploded View	5-2
Figure 5-2	Display Assembly	5-3
Figure 5-3	Model 175A Rear Panel	5-4
Figure 5-4	Segment Identification	5-10

List of Tables

Section 2 — Bench Operation

Table 2-1	Error Messages	2-4
Table 2-2	Model 175A Maximum Allowable Inputs	2-5
Table 2-3	dB Specifications for DC Volts (600 Ω Ref).	2-10
Table 2-4	dB Specifications for AC Volts (600 Ω Ref)	2-10
Table 2-5	Levels for Other Reference Impedances	2-11
Table 2-6	Comparison of Average and TRMS Meter Readings	2-15

Section 3 — Performance Verification

Table 3-1	Recommended Test Equipment	3-2
Table 3-2	Limits for DC Voltage Verification	3-2
Table 3-3	Limits for AC Voltage Verification	3-3
Table 3-4	Limits for Resistance Verification	3-3
Table 3-5	Limits for DC Current Verification	3-4

Section 5 — Maintenance

Table 5-1	Input Terminal Identification	5-3
Table 5-2	Fuse Replacements	5-5
Table 5-3	Recommended Calibration Equipment	5-6
Table 5-4	DC Voltage Calibration	5-7
Table 5-5	AC Voltage Calibration	5-7
Table 5-6	Resistance Calibration	5-8
Table 5-7	HP-85 and BASIC 2.0/4.0 Programming Language Differences	5-9
Table 5-8	Recommended Troubleshooting Equipment	5-10
Table 5-9	Sequential Display Test Steps	5-11
Table 5-10	Troubleshooting Modes	5-12
Table 5-11	Power Supply Checks and Battery Pack (Model 1758) Checks	5-14
Table 5-12	A/D Converter Checks	5-15
Table 5-13	Display Board Checks	5-15

SECTION 1

General Information

1.1 INTRODUCTION

The Keithley Model 175A is a 4-1/2 digit LCD bench/portable digital multimeter. The Model 175A can make the following basic measurements:

1. DC voltage measurements from 10 μ V to 1000V.
2. Resistance measurements from 10m Ω to 200M Ω .
3. True RMS AC voltage measurements from 10 μ V to 750V.
4. DC current measurements from 10nA to 10A.
5. True RMS AC current measurements from 10nA to 2A.

In addition to the above mentioned measurement capabilities, the Model 175A can make DC and AC dB voltage measurements.

1.2 FEATURES

Some important Model 175A features include:

- 4-1/2 digit LCD display
- Electroluminescent backlight
- Fast autoranging
- Bench or portable
- Digital calibration
- 100-point data logger
- 0.03% basic DCV accuracy
- True RMS ACV and ACA

- dBm/Relative functions
- Min/Max reading hold
- Safety input jacks
- 10A capability
- 100kHz specified AC bandwidth

Options include:

- Model 1758 Rechargeable Battery Pack
- Model 1753A IEEE-488 Interface

1.3 WARRANTY INFORMATION

Warranty information may be found on the inside front cover of this manual. Should it be necessary to exercise the warranty, contact your Keithley representative or the factory to determine the proper course of action. Keithley Instruments maintains service facilities in the United States, United Kingdom, and throughout Europe. Information concerning the application, operation, or service of your instrument may be directed to the applications engineer at any of these locations. Check the inside front cover for addresses.

1.4 MANUAL ADDENDA

Information concerning improvements or changes to the instrument that occur after the printing of this manual will be found on an addendum sheet included with the manual. Be sure to review these changes before attempting to operate or service the instrument.

1.5 SAFETY SYMBOLS AND TERMS

The following safety symbols and terms are used in this manual or found on the Model 175A.

The  symbol on the instrument denotes that the user should refer to the operating instructions in this manual.

The  on the instrument denotes that a hazardous potential may be present on the terminal(s). Standard safety practices should be observed when such dangerous levels are encountered.

The **WARNING** used in this manual explains dangers that could result in personal injury or death.

The **CAUTION** used in this manual explains hazards that could damage the instrument.

1.6 SPECIFICATIONS

Detailed Model 175A specifications may be found preceding the Table of Contents of this manual.

1.7 INSPECTION

The Model 175A Autoranging DMM was carefully inspected, both electrically and mechanically, before shipment. After unpacking all items from the shipping carton, check for any obvious signs of physical damage that might have occurred during transit. Report any damage to the shipping agent. Retain and use the original packing materials in case reshipment is necessary. The following items are shipped with every Model 175A order:

Model 175A Autoranging Multimeter

Model 175A Instruction Manual

Model 1751 Safety Test Leads

Additional accessories as ordered.

If an additional instruction manual is required, order the manual package (Keithley Part Number 175A-901-00). The manual package includes an instruction manual and any applicable addenda.

1.8 USING THE MODEL 175A MANUAL

This manual contains information necessary for operating and servicing the Model 175A Autoranging Multimeter and the Model 1758 Rechargeable Battery Pack. The information is divided into the following sections:

- Section 1 contains general information about the Model 175A and Model 1758, including that necessary to inspect the instrument and get it operating as quickly as possible.
- Section 2 contains detailed operating information on using the front panel controls, making connections, and basic measuring techniques for each of the available measuring functions.
- Section 3 contains performance verification procedures for the instrument. This information will be helpful if you wish to verify that the instrument is operating in compliance with its stated specifications.
- Section 4 contains a description of operating theory. Analog, digital, and power supply operation is included.
- Section 5 contains information for servicing the instrument. This section includes information on fuse replacement, line voltage selection, calibration and troubleshooting.
- Section 6 contains replaceable parts information.

NOTE

The Model 1753A IEEE-488 interface comes supplied with its own instruction manual.

1.9 GETTING STARTED

Perform the following steps in sequence to acquaint yourself quickly and safely with the basic operation of the Model 175A.

1. Referring to paragraph 2.3.1 for more complete information, set the **LINE VOLTAGE** switch to the available line power.
2. Connect the female end of the power cord to the AC receptacle on the rear panel of the instrument. Connect the other end of the cord to a grounded AC outlet. If the optional battery pack is installed the charge circuitry will be activated.
3. Turn on the Model 175A by pressing in the **POWER** pushbutton. All of the zeros will be displayed briefly.
4. Connect the supplied test leads to the **VOLTS/OHMS/mA** and **COM** jacks, and short them together.

5. Select AC volts and autoranging by pressing in the AC/DC, V, and AUTO pushbuttons. The AC, mV, and AUTO annunciators will be displayed. Pressing any of the other range pushbuttons will put the Model 175A in manual ranging as indicated by the absence of the AUTO annunciator.
6. Select DC volts by releasing (out) the AC/DC pushbutton (V still selected). The AC annunciator will turn off.
7. Select autoranging ohms by pressing in the Ω pushbutton (DC still selected) and AUTO pushbutton. The Ω annunciator will turn on. Press the AC/DC pushbutton in (AC selected) and note the "Err" message indicating that this is an invalid mode.
8. Select AC or DC current by setting the AC/DC pushbutton accordingly and pressing in the A pushbutton. The annunciator that reflects the selected range will turn on. Note that current will not autorange.
9. Select dB by placing the Model 175A in ac or DC volts and pressing the dB pushbutton. The dB annunciator will turn on. Press the dB button again to take the Model 175A out of the dB measurement mode.
10. REL (relative) can be used with any measurement function: volts, ohms, amps or dB. For example, place the Model 175A in ohms and autorange. The display will read approximately 00.14 Ω , which is the test lead resistance. Press the REL pushbutton. The REL annunciator will turn on and the display will now read 00.00 Ω . The relative level of 0.14 Ω will be subtracted from all subsequent ohm measurements. Press the REL pushbutton a second time to cancel the REL level.
11. To activate the 100-point DATA LOGGER with MIN/MAX, press and hold in the STO/CLR pushbutton. When the reading rate R=0 is displayed, let go of the button. The STO annunciator will turn on. Press the RCL pushbutton and the last data point will be displayed briefly followed by the reading (data). Other data points can be displayed by holding in the RCL button. Turn off the DATA LOGGER by pressing the STO/CLR pushbutton again.
12. Turn on the display backlight by pressing the DISPLAY BACKLIGHT button on the rear panel. Press again to turn off.
13. When you are comfortable with the controls of the Model 175A, go on and make the desired measurements using Section 2, Bench Operation as a guide.

1.10 ACCESSORIES

The following accessories are available to enhance Model 175A capabilities:

Model 1010 Single Rack Mounting Kit — Use to mount one Model 175A in a standard 5-1/4 × 19" rack.

Model 1017 Dual Rack Mounting Kit — Use to mount two Model 175A's in a standard 5-1/4 × 19" rack.

Model 1301 Temperature Probe — A rugged low cost temperature probe designed to allow precision temperature measurements from -55°C to 150°C.

Range: -55°C to 150°C

Output: 1mV/°C; compatible with any DMM with at least 10M Ω input impedance.

Accuracy: $\pm 2^\circ\text{C}$ from 0° to 100°C; $\pm 3^\circ\text{C}$ from -55° to 0°C and 100° to 150°C

Power: 9V alkaline or C-Zn (NEDA 1604) battery.

Model 1600A High Voltage Probe — Extends the DMM to 40kV.

Maximum Input: 40kV DC or peak AC to 300Hz

Input Resistance: 1000M Ω

Division Ratio: 1000:1

Ratio Accuracy: $\pm 2.5\%$ from 1kV to 40kV DC, $\pm 3.5\%$ if 200mV or 2V ranges of Model 175A are used;

-3dB at 300Hz AC.

Operating Temperature: 0° to 50°C

Model 1651 50-Ampere Current Shunt — The external 0.001 Ω $\pm 1\%$, 4-terminal shunt permits current measurements from 0-50A DC or AC.

Model 1681 Clip-On Test Lead Set — Contains two leads, 1.2m (48 inches) long terminated with banana plugs and spring action clip on probes.

Model 1682A RF Probe — Permits voltage measurements from 100kHz to 250MHz.

AC to DC transfer accuracy: $\pm 1\text{dB}$ from 100kHz to 250MHz at 1V, peak responding, calibrated in rms of a sine wave.

Maximum Allowable Input: 42V AC peak, 200V (DC + AC peak)

Model 1684 Hard Shell Carrying Case — Hard vinyl case, 100mm × 300mm × 350mm (4 × 13 × 14 inches) has a fitted foam insert with room for the Model 175A, instruction manual, and small accessories.

Model 1685 Clamp-On AC Probe — Measures AC current by clamping onto a single conductor. Interruption of

the circuit under test is unnecessary. The Model 1685 detects current by sensing the changing magnetic field produced by the current flow.

Range: 2, 20 and 200A rms

Accuracy: $\pm 4\%$ of range at 60Hz; $\pm 6\%$ of range at 50Hz

Temperature Coefficient: $\pm 0.05\%/^{\circ}\text{C}$ on 20A and 200A range; $\pm 0.3\%/^{\circ}\text{C}$ on 2A range

Maximum Allowable Current: 300A rms

Maximum Conductor Voltage: 600V rms

Conversion Ratio: 0.1V/A rms

Model 1751 Safety Test Leads — This is the test lead set supplied with each Model 175A. Finger guards and shrouded banana plugs help minimize the chance of making contact with live circuitry.

Model 1753A IEEE-488 Interface — Field installable programmable option provides isolated data output. Switch selectable talk only or addressable modes. Mounts within and powered by the Model 175A.

Model 1754 Universal Test Lead Kit — 12 piece test lead kit, with interchangeable plug-in accessories. Kit includes: one set of test leads (1-red, 1-black), two spade lugs, two standard banana plugs, two phone tips (.060 dia.), two hooks and two miniature alligator clips (with boots).

Model 1755 Calibration Interface — Permits automated IEEE-488 based verification and calibration of Model 175A without installed interface. An IEEE-488 interface must be installed in the 1755.

Model 1758 Rechargeable Battery Pack — Provides six hours minimum operation from full charge, recharges within 10 hours and is field installable.

Model 7008 IEEE-488 Digital Cable — Useful for connecting the Model 1753A to the IEEE-488 bus. The Model 7008-3 is 0.9m (3ft) in length and has a standard IEEE-488 connector at each end. The Model 7008-6 is 1.8m (6ft) in length.

SECTION 2

Bench Operation

2.1 INTRODUCTION

This section contains the information needed to prepare and operate the Model 175A as a bench DMM. Bench operation consists of using the Model 175A to perform basic voltage, current, resistance and dB measurements. Also, the operation of the data logger is covered here. The capabilities of the Model 175A can be enhanced with the addition of the Model 1753A IEEE-488 interface. IEEE operation is covered in the Model 1753A Instruction Manual.

2.2 HIGH ENERGY CIRCUIT SAFETY PRECAUTIONS

To optimize safety when measuring voltage in high energy distribution circuits, read and use the directions in the following warning.

WARNING

Dangerous arcs of an explosive nature in a high energy circuit can cause severe personal injury or death. If the meter is connected to a high energy circuit when set to a current range, low resistance range, or any other low impedance range, the circuit is virtually shorted. Dangerous arcing can result when the meter is set to a voltage range if the minimum voltage spacing is reduced.

When making measurements in high energy circuits use test leads that meet the following requirements:

- Test leads should be fully insulated.
- Only use test leads that can be connected to the circuit (e.g., alligator clips or spade lugs) for hands-off measurement.
- Do not use test leads that decrease voltage spacing. This diminishes arc protection and creates a hazardous condition.

Use the following sequence when testing power circuits:

1. De-energize the circuit using the regular installed connect-disconnect device such as the circuit breaker, main switch, etc.
2. Attach the test leads to the circuit under test. Use appropriate safety rated leads for this application.
3. Set the DMM to the proper function and range.
4. Energize the circuit using the installed connect-disconnect device and make measurements without disconnecting the DMM.
5. De-energize the circuit using the installed connect-disconnect device.
6. Disconnect the test leads from the circuit under test.

CAUTION

The maximum common-mode input voltage (the voltage between input LO and chassis

ground) is 500V peak. Exceeding this value may damage the instrument.

2.3 PREPARATION FOR USE

2.3.1 Line Power

Use the following procedure to connect the Model 175A to line power and power up the instrument.

1. Check that the instrument is set to correspond to the available line power. Ranges are 105V-125V or 210V-250V 50/60Hz AC. If the line voltage setting of the instrument needs to be changed, set switch as required.

NOTE

Although the Model 175A is specified at 50 and 60Hz, the instrument may be operated at 400Hz and 440Hz. Add one count to instrument specifications under this condition.

2. Connect the female end of the power cord to the AC receptacle on the rear panel of the instrument. Connect the other end of the cord to a grounded AC outlet.

WARNING

The Model 175A is equipped with a 3-wire power cord that contains a separate ground wire and is designed to be used with grounded outlets. Failure to use a grounded outlet may result in personal injury or death because of electric shock.

CAUTION

Be sure that the power line voltage agrees with the indicated range on the rear panel of the instrument. Failure to observe this precaution may result in instrument damage.

2.3.2 Battery Pack Power

The Model 175A may also be operated from rechargeable sealed nickel-cadmium batteries contained in the optional Model 1758 Rechargeable Battery Pack. The bat-

tery pack will operate the Model 175A for up to six hours. The BAT annunciator will turn on when the battery charge is insufficient to maintain accurate readings. Refer to Section 5, paragraph 5.3 for installation and removal procedures.

2.3.3 Battery Charging

The Model 1758 Battery Pack in the Model 175A can be charged and recharged as follows:

1. Connect the instrument to line power as described in paragraph 2.3.1.
2. With the power switch off, the battery charge circuitry is automatically energized to charge the battery at the maximum rate. When the battery pack is first installed, or if it is completely discharged, allow it to charge for ten hours.

NOTE

For maximum battery efficiency, only charge the battery pack after it has become discharged and only charge until it is fully charged (≈ 10 hours). Continuous charging over long periods of time will not damage the batteries but useful life will gradually decrease. This loss is not permanent and may be restored by cycling the battery pack through several complete charge/discharge cycles. The battery pack is capable of 500 to 1000 charge/discharge cycles before replacement is needed. Do not make measurements with the BAT annunciator on as the readings may be erroneous.

3. When the Model 175A is in use on line power, the battery charger maintains a trickle charge on the battery pack.

2.4 FRONT PANEL FAMILIARIZATION

The following paragraphs and Figure 2-1 provide a brief description of the display, front panel controls, and input terminals.

2.4.1 Display

The Model 175A has a 4-1/2 digit liquid crystal display (LCD) with a switch selectable electroluminescent backlight. The minus sign is displayed. The plus sign is im-

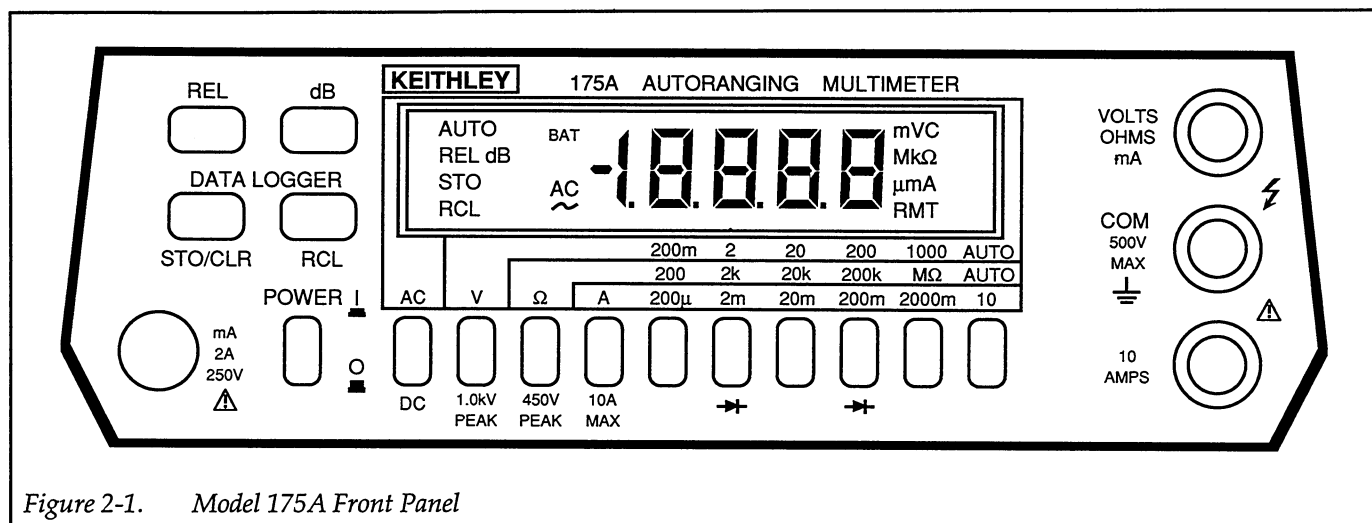

Figure 2-1. Model 175A Front Panel

plied by the absence of the minus sign. The following annunciators are displayed on the LCD.

BAT — Low battery indicator for the Model 1758.

AC — AC selected (DC implied by absence of AC annunciator).

mV or V — Millivolts or volts selected.

Ω , k Ω , or M Ω — Ohms, kilohms, or megohms selected.

μ , mA, or A — Microamps, milliamps, or amps selected.

RMT (Remote) — Model 175A being controlled over the IEEE-488 bus (Model 1753A installed).

C — Model 175A in calibration mode.

AUTO — Autorange selected.

REL — Relative selected.

dB — Decibel selected.

STO — Data being stored.

RCL — Data being recalled. RCL flashes when buffer is full during logging cycle.

A display backlight is incorporated to enhance the display under low light and dark operating conditions. The backlight is turned on/off with the rear panel switch DISPLAY BACKLIGHT.

The brightness of the electroluminescent backlight is affected by the aging of its phosphor layer. The lamp ages rapidly at first, leveling off to 20% brightness after 5000 to 7000 hours of usage. It is recommended to turn the backlight off under bright conditions to extend its useful life.

2.4.2 Front Panel Controls

POWER — Pressing in this pushbutton turns the Model 175A on. Releasing (out) this pushbutton turns the instrument off.

REL (Relative) — This pushbutton allows readings to be made with respect to any baseline value. Also allows zeroing of on range readings. See paragraph 2.7.2 for more detailed information on REL.

dB — This pushbutton selects the dB function and is used along with the ACV or DCV function. Measurements are made in dBm referenced to 600 Ω . REL can be used to make any voltage level the 0dB reference point for dB measurements.

DATA LOGGER — Has min/max and 100-point reading storage capacity; records data at one of six selectable rates from 3 rdg/sec to 1 rdg/hr. Readings for minimum and maximum are sampled at the rate of 3 per second regardless of the selected rate.

1. STO/CLR — Pressing this button initiates the logging sequence. Pressing the button a second time shuts off the data logger.
2. RCL — Pressing and holding this button in scrolls the data pointer. To read the data at a particular point, simply release the button.

Table 2-1. Error Messages

Display	Message	Comments
	RAM Error	Model 175A locks up. See Section 5 for troubleshooting information.
	Calibration Error (NVRAM Failure)	Model 175A locks up, but operation can be restored by pressing any one of the four momentary pushbuttons. If restored, calibration is invalid as indicated by the flashing "C" annunciator. See Section 5 for troubleshooting information.
	Overrange	Overrange input applied to the Model 175A. Leading minus sign indicates that input signal has a negative value.
	Invalid Ω Function	"AC" and "Ω" annunciators flash. Correct problem by releasing (out) AC/DC pushbutton.

AC/DC — This switch is used along with the volts (V), current (A), and dB functions. Depressing (in) this pushbutton selects AC and releasing (out) this pushbutton selects DC.

V — Depressing this pushbutton selects the volts function.

Ω — Depressing this pushbutton selects the ohms function. The AC/DC pushbutton must be released (out).

A — Depressing this pushbutton selects the current function.

Range Push Buttons

1. AUTO — Depressing this pushbutton causes volts and ohms to autorange (no autoranging in current).
2. Manual ranging is accomplished by depressing the appropriate range button.

2.4.3 Input Terminals

The input terminals are intended to be used with safety shrouded test leads to help minimize the possibility of

contact with live circuits. Safety shrouded test leads are supplied with the Model 175A.

VOLTS/OHMS/mA and COM (Red and Black) – Use this pair of terminals for all volt, ohm, milliamp, and dB measurements.

10AMPS and COM (White and Black) – Use this pair exclusively for measuring current up to 10A (up to 20A for 15 seconds).

2.4.4 Current Fuse Replacement

The current fuse protects the 200μA through 2000mA ranges from an input current greater than 2A. See paragraph 5.5 for fuse replacement procedures.

2.5 ERROR MESSAGES

Table 2-1 lists the error messages associated with basic front panel operation. Note that the instrument has a number of other messages that are discussed in the appropriate sections of this manual.

2.6 OPERATING CONDITIONS

2.6.1 Environmental Conditions

All measurements should be made at an ambient temperature within the range of 0°C to 50°C, and with a rela-

tive humidity of 0% to 80% up to 35°C. For instruments above 35°C derate humidity 3% per °C up to 50°C. If the instrument has been subjected to extremes of temperature, allow sufficient time for internal temperatures to reach environmental conditions. Typically, it takes one hour to stabilize a unit that is 10°C (18°F) out of specified temperature range.

2.6.2 Maximum Allowable Inputs

Table 2-2 lists the maximum allowable inputs for the Model 175A.

2.7 BASIC BENCH MEASUREMENTS

Basic measurement techniques for using the Model 175A to measure AC and DC volts, resistance, AC and DC current, and dB are covered in the following paragraphs. Also included is the operation of the MIN/MAX and 100-point data logger.

WARNING

Before operating the Model 175A, observe the safety precautions found preceding Section 1. When testing high energy power circuits follow the procedure found in paragraph 2.2, High Energy Circuit Safety Precautions. Failure to observe these and other

safety precautions found in this manual could result in severe injury or death.

The COM terminal on the Model 175A is designed to float above earth ground to avoid ground loop problems.

WARNING

Hazardous voltages may be applied to the COM terminal. The maximum allowable voltage between the COM terminal and chassis ground is 500V. Destruction of insulation, which could present a shock hazard, may occur if the 500V maximum is exceeded.

CAUTION

Do not exceed the maximum input limits shown in Table 2-2.

2.7.1 Power-Up

NOTE

The software revision level of the Model 175A can be displayed upon power-up by running the diagnostic program. See Section 5, Maintenance, for more information.

Turn on the Model 175A by pressing in the POWER switch. The following will occur:

1. Reset — All zeros will be briefly displayed before going into the measurement mode.

Table 2-2. Model 175A Maximum Allowable Inputs

Function	Ranges	Maximum Allowable Inputs
DC Volts	200mV, 2V	1000VDC or peak AC for less than 10sec per minute. 300Vrms continuous.
	20-1000V	1000VDC or peak AC.
AC Volts	200mV	750Vrms, 1000V peak for less than 10sec per minute. 300Vrms continuous. 10 ⁷ V•Hz maximum.
	2-750V	750Vrms, 1000V peak. 10 ⁷ V•Hz maximum.
DC and AC Current	200μ-2000mA 10A	2A, 250VDC or rms (fuse protected). 10A continuous, 20A for 15sec (unfused).
Ω	All	450VDC or peak AC

2. RAM Test — If this test fails the Model 175A will lock up with zeros displayed.
3. NVRAM Test — If this test fails the display will show the error message “cErr”.

Refer to Table 2-1 for more information pertaining to error messages.

2.7.2 Relative Mode

When the relative mode is selected with an on-scale reading on the display the following occurs:

1. The REL annunciator is displayed.
2. The next reading is stored.
3. The stored reading is then algebraically subtracted from all subsequent readings and displayed.

A REL level can be established for any measurement function (Volts, Ohms, Amps, and dB) and is effective only on that function. Changing functions will not affect a REL level already established. However, if another REL level is set (on any function), the previous REL level will be cancelled.

For example, place the 175A in the Ω function and select the 200 Ω range. Short the test leads and press the REL button. Note that the REL annunciator is on. Select DCV and note that the REL annunciator is off, indicating that there is not a REL level established for DCV. Switch back to Ω and note that the REL level is still there. Again, go to DCV and set a REL level of +1V. The REL annunciator will go on. Switch back to Ω and note that the REL annunciator is off, indicating that the REL level for Ω is cancelled.

Once a REL level is established for a measurement function, that stored level will be the same regardless of what range the Model 175A is on. For example, if +1V is established as the REL level on the 20VDC range, +1V will also be the REL level on the 1000VDC range.

It is important to note that the use of REL reduces the dynamic range of measurements by that level. For instance, assume that the REL level is +1V and the Model 175A is manually set to the 2V range. The maximum positive displayed reading, before overranging, would be +0.9999V. This is because the A/D converter would be seeing 1.9999V (maximum) from the input. Thus, the dynamic

range of measurement is -1.9999V to $+0.9999\text{V}$ (2.9998V) as compared to the normal -1.9999V to $+1.9999\text{V}$ (3.9998V). The dynamic range of measurement has been reduced by 1V. The effects on dynamic range can be reduced by selecting a higher range or using autorange.

2.7.3 DC Voltage Measurements

The Model 175A can make DC voltage measurements between 10 μV and 1000V. The basic procedure is as follows:

1. Connect the test leads to the VOLTS and COM terminals of the Model 175A.
2. Select the DCV function.
3. Select a range consistent with the expected voltage. For automatic range selection, press in the AUTO pushbutton.

NOTE

Manual ranging is recommended for routine measurements above 200V.

4. Connect the test leads to the source as shown in Figure 2-2. If the positive source terminal is connected to the COM terminal of the instrument, the display will show a negative value. If the negative source terminal is connected to the COM terminal, the display will show a positive value.
5. Observe the display; if the “OL” message is shown, select a higher range until a normal reading is shown. Always use the lowest possible range for the best resolution.
6. Take the reading from the display.

NOTE

High input impedance ($>1000\text{M}\Omega$) DC volts measurements can be made on the 200mV and 2V ranges by releasing (out) all the function pushbuttons (AC/DC, V, Ω , A).

2.7.4 TRMS AC Voltage Measurements

The Model 175A can make AC voltage measurements between 10 μV and 750V. Proceed as follows:

1. Connect the test leads to the VOLTS and COM terminals of the Model 175A.
2. Select the ACV function.
3. Select a range consistent with the expected voltage. For automatic range selection, press in the AUTO pushbutton.

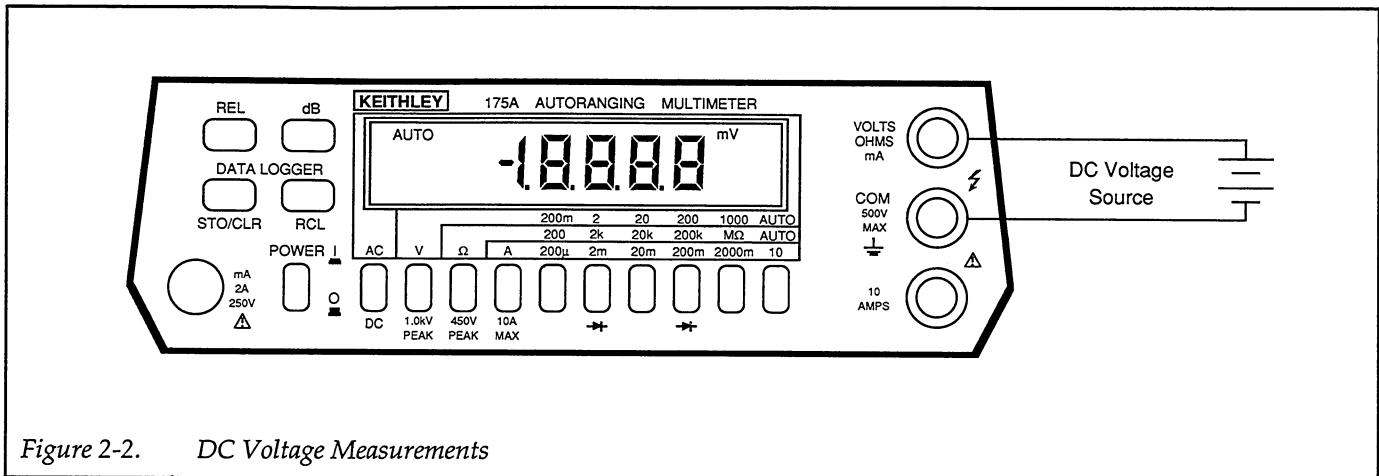

Figure 2-2. DC Voltage Measurements

NOTE

Manual ranging is recommended for routine measurements above 200V.

4. Connect the test leads to the source as shown in Figure 2-3.
5. Observe the display; if the "OL" message is shown, select a higher range until a normal reading is shown. Always use the lowest possible range for the best resolution.
6. Take the reading from the display.

NOTE

See paragraph 2.8 for TRMS considerations.

2.7.5 Resistance Measurements

The Model 175A can make resistance measurements between 10mΩ and 200MΩ. The 2MΩ, 20MΩ, and 200MΩ ranges will autorange when the MΩ pushbutton is pressed in. Proceed as follows to make resistance measurements:

1. Connect the test leads to the OHMS and COM terminals of the Model 175A.
2. Select the Ω function.

NOTE

The message "Err" and flashing Ω and AC annunciators will be displayed if the AC/DC pushbutton is pressed in. This is an invalid mode. To correct, simply release (out) the AC/DC pushbutton.

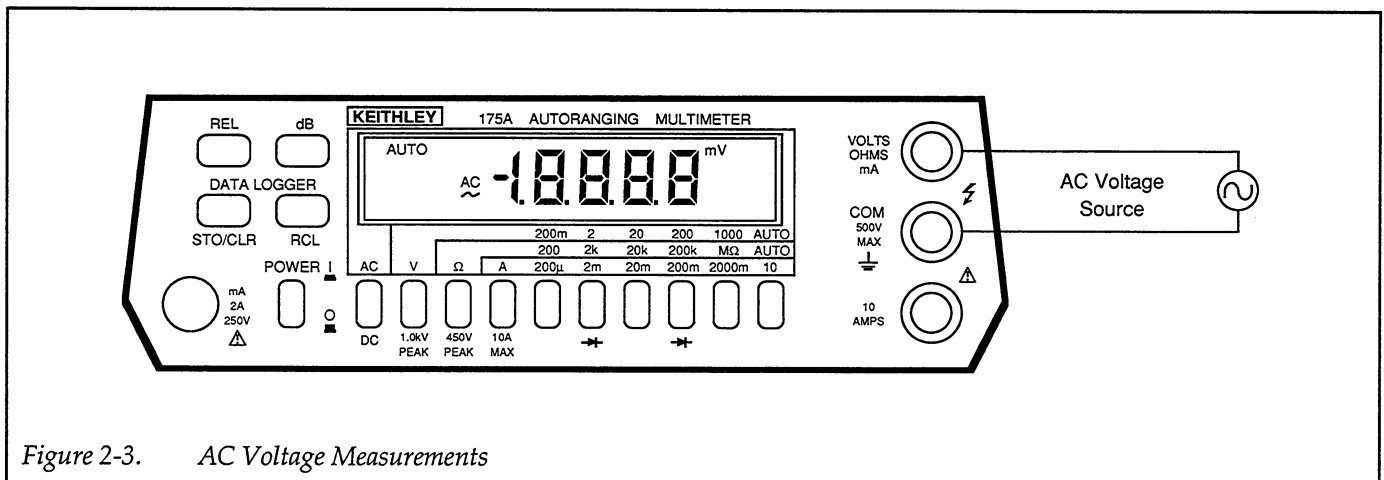

Figure 2-3. AC Voltage Measurements

3. Select a range consistent with the expected resistance. For automatic range selection, use the autorange mode.

NOTE

Zeroing may be necessary to compensate for test lead resistance on the 200Ω and 2kΩ ranges. Zero the display as follows:

- A. Short the test leads together.
 - B. Press the REL pushbutton. The display will zero.
 - C. Proceed to step 4.
4. Connect the test leads to the resistance to be measured as shown in Figure 2-4.
 5. Observe the display; if the "OL" message reading is shown, select a higher range until a normal reading is shown. Always use the lowest possible range for the best resolution.
 6. Take the reading from the display.

NOTE

It is helpful to shield resistances greater than 10⁶Ω (1MΩ) if a stable reading is expected. Place the resistance in a shielded enclosure and electrically connect the shield to COM of the Model 175A.

2.7.6 Current Measurements (DC or TRMS AC)

The Model 175A can make DC or TRMS AC current measurements between 10nA and 10A (20A for 15 seconds). If the expected current level is in question, make the initial measurement with the 10A range. This will

help prevent the inadvertent blowing of the 2A current fuse.

NOTE

For routine measurements above 10A it is recommended that the Model 1651, 50-Ampere current shunt be used.

For current measurements between 2000mA and 20A:

1. Connect the test leads to the 10 AMPS and COM terminals of the Model 175A.

NOTE

The test leads used must be capable of handling 20A. It is recommended that they be twisted (see Figure 2-5) to minimize external fields that could affect the Model 175A or other equipment. Also, keep the test leads as short as possible to minimize voltage drop.

2. Select the ACA or DCA function.
3. Select the 10A range. Current measurements do not autorange.
4. Connect the test leads to the current source as shown in Figure 2-5 and make the reading from the display.

NOTE

Up to 5A may be applied continuously without degradation of the measurement due to self-heating effects. Above 5A derate 0.15% readings per amp for self-heating. For currents between 10A and 20A, specified accuracy can only be obtained when measure-

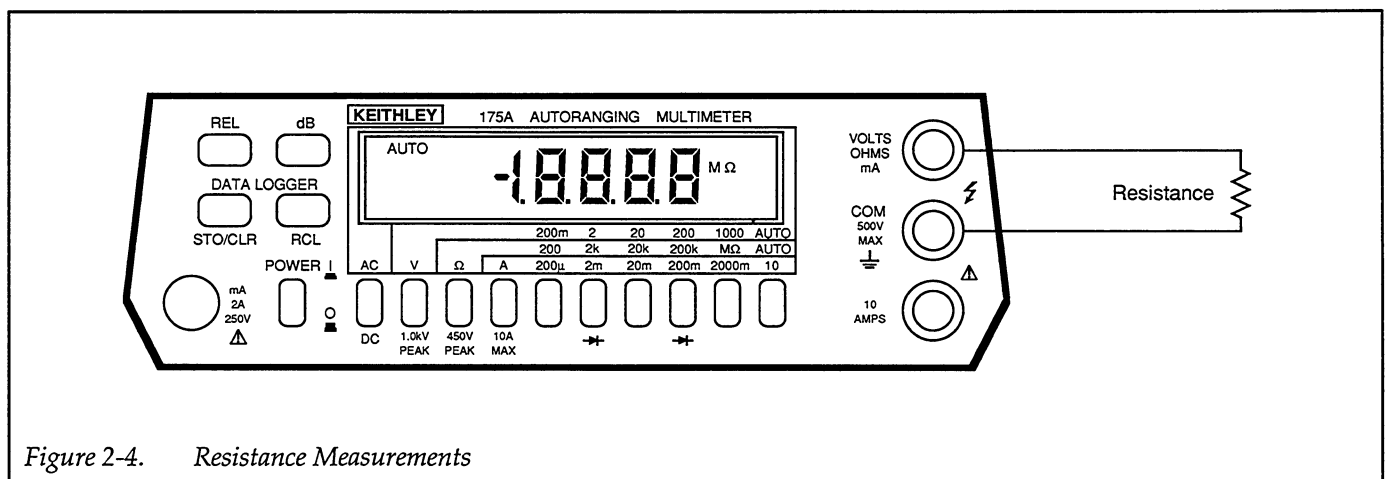

Figure 2-4. Resistance Measurements

ments are limited to a maximum of 15 seconds.

2.7.7 AC plus DC Measurements

Use the Model 175A to measure TRMS on a signal that has both AC and DC components as follows.

For current measurements up to 2000mA:

1. Connect the test leads to the mA and COM terminals of the Model 175A.
2. Select the ACA or DCA function.
3. Select an appropriate range for the expected current. Current measurements cannot autorange.
4. Connect the test leads to the current source as shown in Figure 2-6. If an overrange indication is displayed, select a higher range until a normal reading is shown. Use the lowest possible range for the best accuracy.
5. Make the reading from the display.

1. Measure and record the TRMS AC component as described in paragraph 2.7.4.
2. Measure and record the DC component as described in paragraph 2.7.3.
3. Compute the rms value from the following equation:

$$E_{RMS} = \sqrt{(E_{AC})^2 + (E_{DC})^2}$$

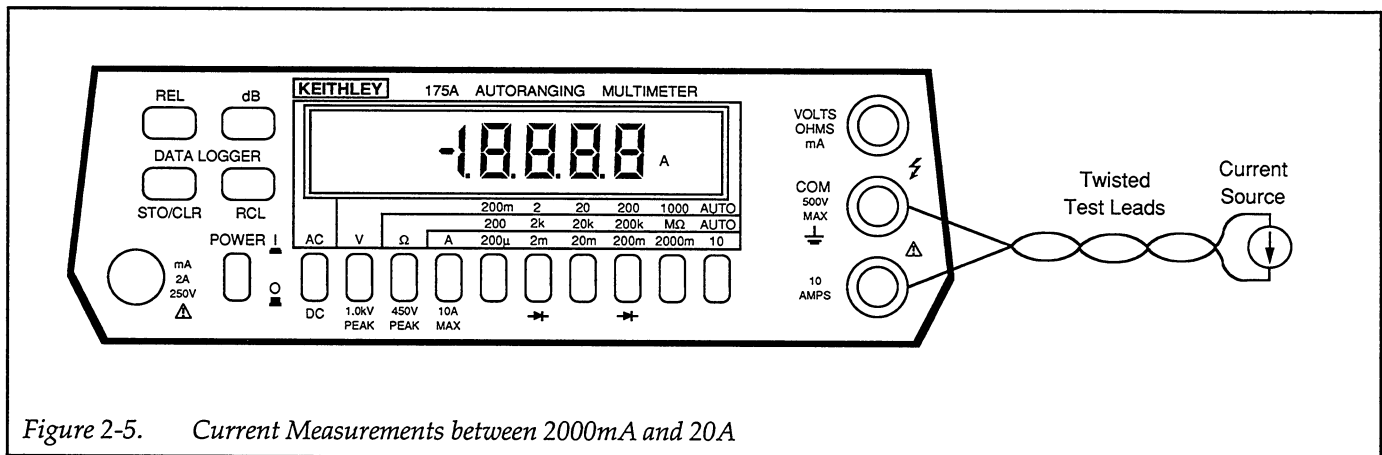

Figure 2-5. Current Measurements between 2000mA and 20A

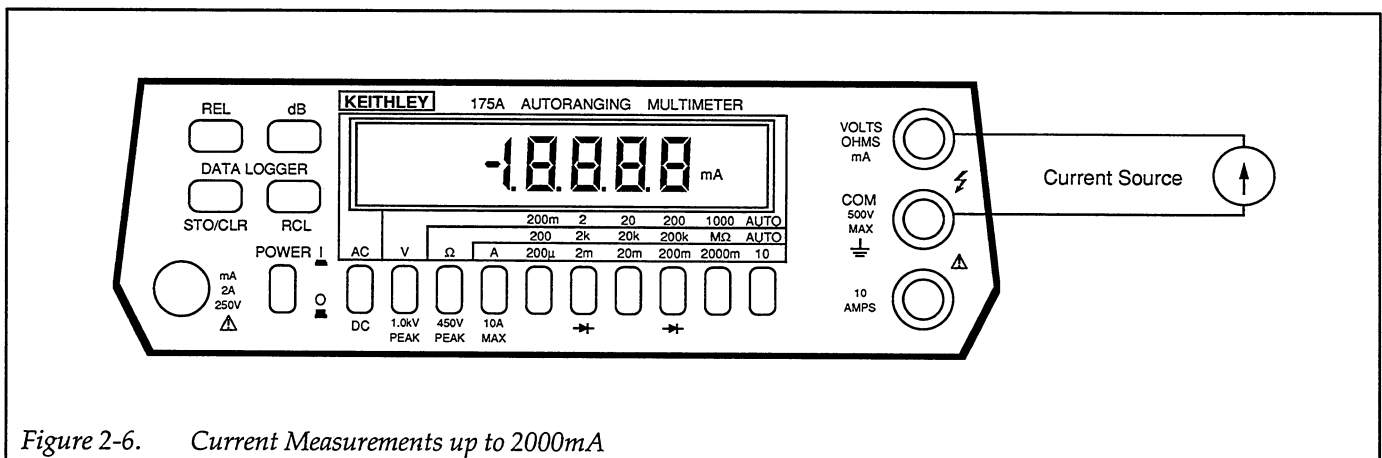

Figure 2-6. Current Measurements up to 2000mA

2.7.8 dB Measurements

The dB function makes it possible to compress a large range of readings into a much smaller scope. The relationship between dB and voltage can be expressed by the following equation.

$$\text{dB} = 20 \log \frac{V_{\text{OUT}}}{V_{\text{REF}}}$$

Tables 2-3 and 2-4 list the dB specifications for DC volts and AC volts.

Table 2-3. dB Specifications for DC Volts (600Ω Ref).

Linear Counts	Resolution	Accuracy
10 – 99	1 dBm	±1 dBm
100 – 999	0.1 dBm	±0.1 dBm
1000 – 20000	0.01 dBm	±0.02 dBm

The Model 175A can make dBm measurements referenced to the standard 600Ω impedance or to other impedances. The relative feature allows measurements in dB independent of impedance.

The basic procedure for placing the instrument in the dB mode is to first select AC or DC volts and then press the dB button. Note that once dB is selected (dB annunciator

on) pressing in the Ω or A function pushbuttons will turn dB off.

dBm Measurements with 600Ω Reference Impedance

A dBm measurement is defined as decibels above or below a 1mW reference. The standard reference impedance of the Model 175A is 600Ω. What this means is that the Model 175A is designed to read 0dBm when the calculated voltage needed to dissipate 1mW through a 600Ω impedance is applied to the Model 175A. That calculated voltage level is 0.7746V as derived from the basic power equation.

$$E = \sqrt{P \cdot R}$$

$$E = \sqrt{10^{-3}\text{W} \cdot 600\Omega}$$

$$E = 0.7746\text{V}$$

Thus, with a 600Ω reference impedance, the Model 175A will read 0dBm whenever 0.7746V is applied.

NOTE

Do not confuse reference impedance with input impedance. The input impedance of the instrument is still 10MΩ (see specifications) in the dB mode.

To make dBm measurements referenced to 600Ω, proceed as follows:

1. Connect the test leads to the VOLTS and COM terminals of the Model 175A.

Table 2-4. dB Specifications for AC Volts (600Ω Ref)

dB Mode (ref: 600Ω)		Accuracy (± dBm)			
Range	Input	20Hz-10kHz	10kHz-20kHz	20kHz-50kHz	50kHz-100kHz
200mV	1mV to 2mV (-58 to -52dBm)	2*	—	—	—
	2mV to 20mV (-52 to -32dBm)	2	3	—	—
	20mV to 200mV (-32 to -12dBm)	0.2	0.3	1	—
2V-750V	200mV to 750V (-12 to +59.8dBm)	0.2	0.26	0.56	1.2

*Up to 1kHz

2. Select the ACV or DCV function.
3. Select autorange for optimum resolution.
4. Press the dB button.
5. Connect the test leads to the voltage source.
6. Make the dBm reading from the display.

dBm Measurements with Other Reference Impedances

A dBm measurement can be made with other reference impedances. The most convenient method for using other reference impedances is to algebraically subtract the calculated dB offset for the desired reference impedance from the reading on the display of the Model 175A. Table 2-5 lists common reference impedances and the corresponding offset values. The following equation can be used to calculate the offset for impedances not listed in Table 2-5:

$$\text{Offset (for dBm)} = 10 \log \frac{\text{New ref } Z}{600\Omega}$$

Table 2-5. Levels for Other Reference Impedances

Reference Impedance (Ω)	Equiv. Voltage Level for:		Offset (600Ω Ref)	
	0dBm	0dBW	0dBm	0dBW
8	0.0894	2.828	-18.75	11.25
50	0.2236		-10.79	
75	0.2739		-9.03	
150	0.3873		-6.02	
300	0.5477		-3.01	
600	0.7746		0.00	
1000	1.0000		2.22	

$$V_{\text{equiv. for 0dBm}} = \sqrt{10^{-3}\text{W} \cdot Z_{\text{REF}}}$$

$$V_{\text{equiv. for 0dBW}} = \sqrt{Z_{\text{REF}}}$$

$$\text{Offset (for 0dBm)} = 10 \log \left(\frac{Z_{\text{REF}}}{600\Omega} \right)$$

$$\text{Offset (for 0dBW)} = 10 \log \left(\frac{Z_{\text{REF}}}{600\Omega \cdot .001} \right)$$

To make dBm measurements referenced to another impedance, proceed as follows:

1. Choose the desired reference impedance.
2. Calculate or look up the offset value in Table 2-5 for the desired reference impedance.
3. Determine dBm at the desired reference impedance as follows:

$$\text{dBm (at ref } Z) = (175\text{A reading}) - \text{offset}$$

For example, when making dBm measurements referenced to a 100Ω reference impedance, the offset is calculated as follows:

$$\text{Offset} = 10 \log \frac{100\Omega}{600\Omega} = -7.78\text{dB}$$

This offset value must be subtracted from all subsequent displayed readings on the Model 175A.

For those dBm measurements which are referenced to another impedance, they can be read directly from the display of the Model 175A by using the REL feature, and an accurate voltage source. The basic procedure is as follows:

- Calculate or look up the equivalent voltage level (Table 2-5) for 0dBm at the desired reference impedance.
- Input that voltage level to the Model 175A.
- With the Model 175A in the dB mode, press the REL button.
- dBm measurements referenced to the desired impedance can now be read directly from the display of the Model 175A.

dBW Measurements

A dBW measurement is defined as decibels above or below a one watt reference. The procedure is the same as that found under dBm Measurements with Other Reference Impedances. The only difference is that the reference point is 0dBW (1W) rather than 0dBm (1mW).

dBV Measurements

A dBV measurement is defined as decibels above or below 1V (0dBV point). This is a voltage relationship independent of impedance. The basic procedure is to simply

subtract 2.22dB (Table 2-5) from all subsequent displayed readings on the Model 175A.

Relative dB Measurements

Just about any voltage level within the measurement limits of the Model 175A can be established as the 0dB point. The basic procedure is to establish that level as the 0dB point by using REL and make the desired dB measurements.

2.7.9 dB Measurement Considerations and Applications

Typical Instrument Performance

Typically, the Model 175A will perform better than its published dB specification. The following example will illustrate this point:

1. Using the Model 175A in the dB mode (600Ω ref), measure a 1mV rms, 1kHz source (common application in the communications field). Typically, the Model 175A will read -57.7dBm.
2. The calculated dBm level for that source is -57.8dBm.
3. The 0.1dBm error is considerably better than the +2dBm specification. The specifications are intended to cover worst measurement conditions.

Measuring Circuit Gain/ Loss

Any point in a circuit can be established as the 0dB point. Measurements in that circuit are then referenced to that point expressed in terms of gain (+dB) or loss (-dB). To set the 0dB point:

1. Place the Model 175A in volts, autorange, and dB.
2. Connect the Model 175A to the desired location in the circuit.
3. Press the REL button. The display will read 0dB.
4. Gain/loss measurements can now be made referenced to the 0dB point.

Measuring Bandwidth

The Model 175A can be used to determine the bandwidth of an amplifier as follows:

1. Connect a signal generator to the input of the amplifier.
2. Set the Model 175A to ACV and autorange.
3. Connect the DMM and a frequency counter to the load of the amplifier.
4. Adjust the frequency of the signal generator (<300kHz) until a peak AC voltage reading is measured on the Model 175A.
5. Press the dB button and then press the REL button. The 0dB point is now established.
6. Increase the frequency input until the Model 175A reads -3.00dB. The frequency measured on the frequency counter is the high end limit of the bandwidth.
7. Decrease the frequency input until the dB reading again falls to -3dB. The frequency measured on the signal generator is the low end limit of the bandwidth.

Determining Q

The Q of a tuned circuit can be determined as follows:

1. Determine the center frequency and bandwidth as explained in Measuring Bandwidth.
2. Calculate Q by using the following formula:

$$Q = \text{Center Frequency} / \text{Bandwidth}$$

2.7.10 MIN/MAX and 100-Point Data Logger Operation

The data logger can store up to 100 readings and store the minimum and maximum readings recorded during the period that the data logger is active. The data logger remains active even after 100 points of data are stored, which means the MIN/MAX readings continue to update. The only way to deactivate the data logger is to press the STO/CLR button (STO annunciator off) or cycle power.

The 100 points of data are stored at one of six selectable rates from three per second to one reading per hour. Readings for minimum and maximum are sampled at the rate of three per second regardless of the selected rate. The procedure for operating the data logger is as follows:

1. Connect the desired measurement configuration to the Model 175A. Make sure that the controls of the Model 175A are set appropriately.
2. Logging data:
 - A. Press and hold the STO/CLR pushbutton. The following reading rates will scroll on the display:

- r = 0 (every reading)
- r = 1 (1 rdg/sec)
- r = 2 (1rdg/10sec)
- r = 3 (1 rdg/min)
- r = 4 (1 rdg/10 min)
- r = 5 (1 rdg/hr)

NOTE

There is no need to select a rate if just minimum/maximum readings are desired. Momentarily press the STO/CLR button to start the logger.

- B. Release the STO/CLR pushbutton when the desired reading rate is displayed. The STO annunciator will turn on and data will be logged at the selected rate.

NOTE

The logging cycle can be terminated at any time by pressing the STO/CLR button. This shuts off the data logger. However, data is retained and can be recalled at any time as long as the instrument remains on.

- 3. Data retrieval — Data can be retrieved at any time, but a flashing RCL annunciator indicates that the maximum number of readings (100) has been stored.
 - A. Press and hold in the RCL pushbutton. The display will scroll through the data points and MIN/MAX (LO/HI). The first data point displayed will be the last stored reading. The next two data points will be the HI and LO readings made during that logging cycle. Notice that the longer the RCL pushbutton is held in the faster the data points will scroll on the display.
 - B. Release the RCL pushbutton at the desired data point and note the reading (data) on the display. The data pointer can be incremented by steps of one by momentarily holding in the RCL pushbutton.
- 4. Shut off the data logger by pressing the STO/CLR pushbutton. All stored data will be retained until a new store cycle has commenced.

2.7.11 Diode Test

The 2kΩ and 200kΩ ranges can be used for testing semiconductor junctions as follows:

- 1. Select Ω function.
- 2. Press 2k and 200k pushbuttons (diode symbols) in simultaneously.
- 3. Display reads forward V drop of diode at 0.7mA (up to 2V). Red terminal is positive.

2.8 TRMS CONSIDERATIONS

Most DMMs actually measure the average value of an input waveform but are calibrated to read its rms equivalent. This poses no problem as long as the waveform being measured is a pure, low-distortion sine wave. For complex, non-sinusoidal waveforms, however, measurements made with an averaging type meter can be inaccurate.

Because of its TRMS (true root mean square) measuring capabilities, the Model 175A provides accurate AC measurements for a wide variety of AC input waveforms.

2.8.1 TRMS Measurement Comparison

The rms value of a pure sine wave is equal to 0.707 times its peak value. The average value of such a waveform is 0.637 times the peak value. Thus, for an average-responding meter, a correction factor must be designed in. This correction factor (K) can be found by dividing the rms value by the average value as follows:

$$K = \frac{0.707}{0.637} = 1.11$$

By applying this correction factor to an averaged reading, a typical meter can be designed to give the rms equivalent. This works fine as long as the waveform is a pure sine, but the ratios between the rms and average values of different waveforms can vary considerably.

Table 2-6 shows a comparison of common types of waveforms. For reference, the first waveform is an ordinary sine wave with a peak amplitude of 10V. The average value of the voltage is 6.37V, while its rms value is 7.07V. If we apply the 1.11 correction factor to the average reading, it can be seen that the average reading will equal the rms value, resulting in no error for an average-type meter reading.

The situation changes with the half-wave rectified sine wave. As before, the peak value of the waveform is 10V, but the average value drops to 3.18V. The rms value of this waveform is 5.00V, but an average responding meter will give a reading of 3.53V (3.18×1.11), creating an error of 29.4%.

A similar situation exists for the rectified square wave, which has an average value of 5V and an rms value of 5V. The average responding meter gives a reading of 5.55V (5×1.11), while the Model 175A give a TRMS reading of 5V. Other waveform comparisons can be found in Table 2-6.

2.8.2 AC Voltage Offset

Typically the Model 175A will display 25 counts or less of offset on AC volts with the input shorted. This offset is caused by amplifier noise and offset of the TRMS converter. This offset will not affect reading accuracy and should not be zeroed out using the REL feature. The following equation expresses how this offset (V_{OFFSET}) is added to the signal input (V_{IN}):

$$\text{Displayed Reading} = \sqrt{(V_{\text{IN}})^2 + (V_{\text{OFFSET}})^2}$$

As long as V_{IN} is at least 10 times larger than V_{OFFSET} , negligible error will occur.

Example: Range = 2VAC
Offset = 25 counts
Input = 200mV rms

$$\begin{aligned} \text{Displayed Reading} &= \sqrt{(0.2)^2 + (.0025)^2} \\ &= \sqrt{0.04 + 0.0000063} \\ &= \sqrt{0.0400063} \\ &= .20000\text{V rms} \end{aligned}$$

If REL is used to zero the display, the 25 counts of offset would be subtracted from V_{IN} , resulting in an error of 25 counts in the displayed reading.

2.8.3 Crest Factor



The crest factor of a waveform is the ratio of its peak value to its rms value. Thus, the crest factor specifies the dynamic range of a TRMS instrument. For sinusoidal waveforms, the crest factor is 1.414. For a symmetrical square wave, the crest factor is unity.

The crest factor of other waveforms will, of course, depend on the waveform in question because the ratio of peak to rms value will vary. For example, the crest factor of a rectangular pulse is related to its duty cycle; as the duty cycle decreases, the crest factor increases. The Model 175A has a crest factor of three, which means the instrument will give accurate measurements of rectangular waveforms with duty cycles as low as 10%.

2.8.4 Extended Frequency Response

Figure 2-6 illustrates the extended frequency response of the AC voltage ranges up to 1MHz.

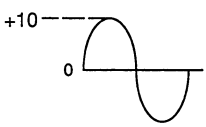
Table 2-6. Comparison of Average and TRMS Meter Readings

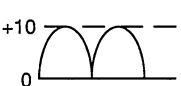
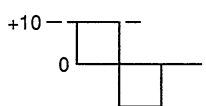
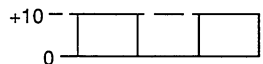
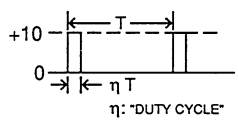
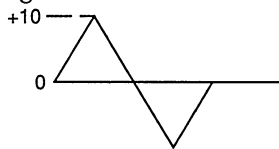
Waveform	AC Coupled Peak Value	RMS Value	Average Responding Meter Reading	AC Coupled TRMS Meter Reading	Averaging Meter Percent Error
Sine 	10V	7.07V	7.07V	7.07V	0%
Half-Wave Rectified Sine 	10V	5.00V	3.53V	5.00V	29.4%
Full-Wave Rectified Sine 	10V	7.07V	7.07V	7.07V	0%
Square 	10V	10.00V	11.10V	10.00V	11%
Rectified Square Wave 	10V	5.00V	5.55V	5.00V	11%
Rectangular Pulse 	10V	$10V \cdot \sqrt{\eta}$	$11.1V \cdot \eta$	$10V \cdot \sqrt{\eta}$	$(1.11 \sqrt{\eta} - 1) \times 100\%$
Triangular Sawtooth 	10V	5.77V	5.55V	5.77V	3.8%

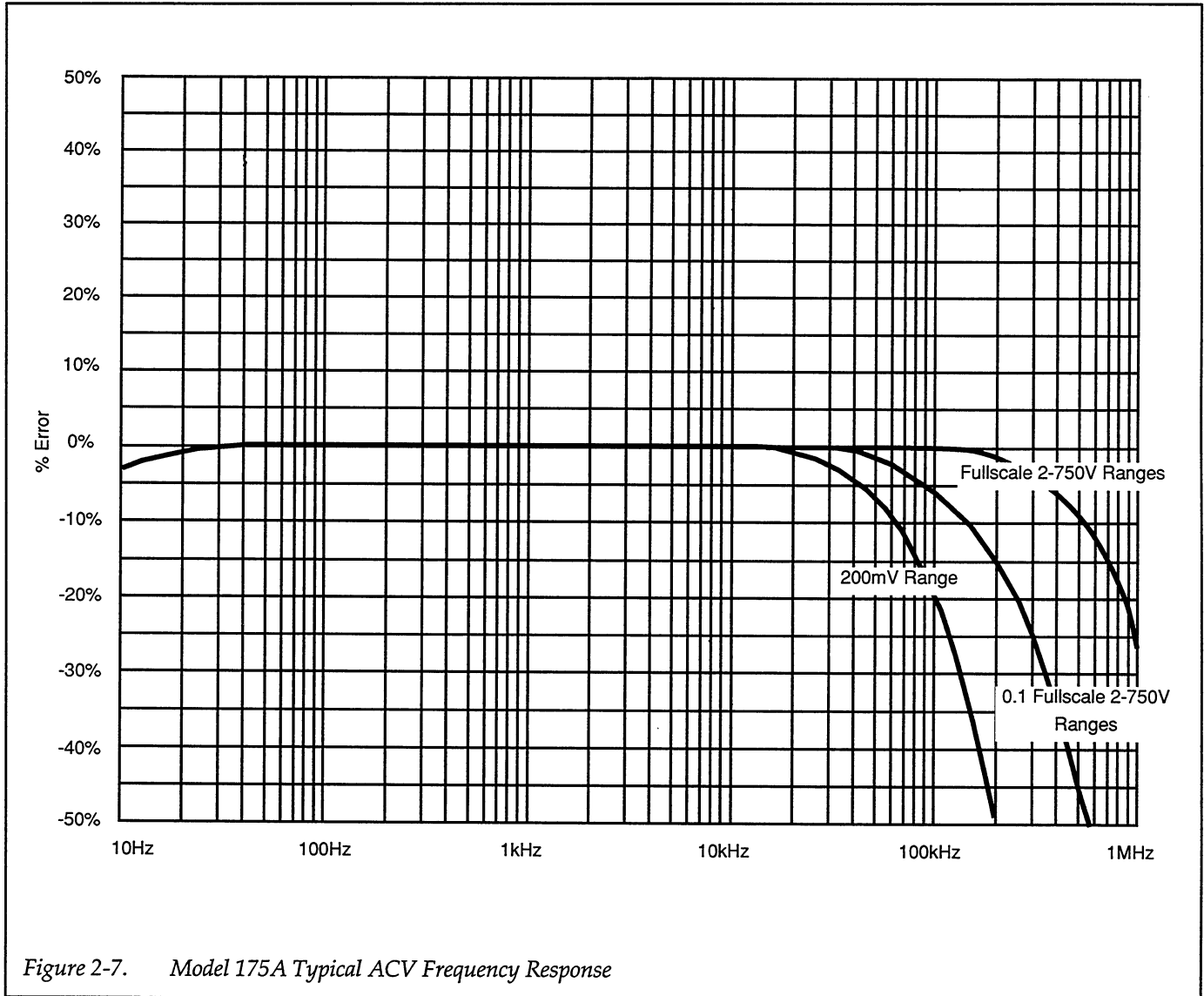

Figure 2-7. Model 175A Typical ACV Frequency Response

SECTION 3

Performance Verification

3.1 INTRODUCTION

The procedures outlined in this section may be used to verify that the instrument is operating within the limits stated in the specifications at the front of this manual. Performance verification may be done when the instrument is first received to ensure that no damage or misadjustment has occurred during shipment. Verification may also be performed whenever there is a question of instrument accuracy, or following calibration, if desired.

NOTE

If the instrument is still under warranty (less than one year from the date of shipment), and its performance falls outside the specified range, contact your Keithley representative or the factory to determine the correct course of action.

3.2 ENVIRONMENTAL CONDITIONS

All measurements should be made at 18-28°C (65-82°F) and at less than 80% relative humidity.

3.3 INITIAL CONDITIONS

The Model 175A must be turned on and allowed to warm up for at least one hour before beginning the verification procedures. The instrument may be operated from either line power or battery pack power, as long as the battery

pack has been fully charged as described in paragraph 2.3.3.

If the instrument has been subject to extremes of temperature (outside the range specified in paragraph 3.2), additional time should be allowed for internal temperatures to reach normal operating temperature. Typically, it takes one additional hour to stabilize a unit that is 10°C (18°F) outside the specified temperature range.

3.4 RECOMMENDED TEST EQUIPMENT

Table 3-1 lists all test equipment required for verification. Alternate equipment may be used as long as the substitute equipment has specifications at least as good as those listed in the table.

NOTE

The verification limits in this section do not include test equipment tolerance.

3.5 VERIFICATION PROCEDURE

The following paragraphs contain procedures for verifying the specifications of the instrument for each of its five measuring functions: DC volts, AC volts, ohms, DC amps, and AC amps. These procedures are intended for use only by qualified personnel using accurate and reliable test equipment. If the unit is out of specifications and not under warranty, refer to Section 5 for calibration procedures.

Table 3-1. Recommended Test Equipment

Manufacturer	Model	Description	Specifications
Fluke	5101B	DC Voltage Calibrator	200mV, 2V, 20V, 200V, 1000V ranges, $\pm 0.005\%$
		AC Voltage Calibrator	200mV, 2V, 20V, 100V, 50Hz to 10kHz, $\pm 0.05\%$
		Resistance Calibrator	100 Ω , 1k Ω , 10k Ω , 100k Ω ranges, $\pm 0.005\%$; 1M Ω range $\pm 0.01\%$; 10M Ω range, $\pm 0.05\%$
		DC Current Calibrator	200 μ A, 2mA, 20mA, 200mA, 2000mA ranges, $\pm 0.025\%$
Fluke	5200A	AC Voltage Calibrator	100mV, 1V, 10V, 100V ranges; 20Hz-50Hz, $\pm 0.1\%$; 20kHz-100kHz, $\pm 0.05\%$
Fluke	5205A	Power Amplifier	1000V range; 10Hz-30Hz, $\pm 0.12\%$; 50kHz-100kHz, $\pm 0.10\%$

WARNING

The maximum common-mode voltage (voltage between input low and chassis ground) is 500V peak. Exceeding this value may cause a shock hazard. Some of the procedures in this section may expose the user to dangerous voltages. Use standard safety precautions when such dangerous voltages are encountered.

Table 3-2. Limits for DC Voltage Verification

DCV Range	Applied DC Voltage	Allowable Readings (18°C to 28°C)
200 mV	100.000 mV	99.94 to 100.06
2 V	1.00000 V	0.9995 to 1.0005
20 V	10.0000 V	9.995 to 10.005
200 V	100.000 V	99.95 to 100.05
1000 V	1000.00 V	999.5 to 1000.5

3.5.1 DC Voltage Verification

CAUTION

Do not exceed 1000V between the VOLTS/OHMS/mA and COM terminals or damage to the instrument may occur.

1. Select the DCV function and 200mV range.
2. Connect the calibrator to the instrument.
3. Apply +100.000mVDC to the Model 175A. The reading must be within the limits specified in Table 3-2.
4. For each remaining range, apply the required voltage as specified in Table 3-2, and verify that the reading is within specifications.
5. Repeat all checks with negative voltage.

3.5.2 AC Voltage Verification

CAUTION

Do not exceed 750V rms, 1000V peak, 10⁷V•Hz, between the VOLTS/OHMS/mA and COM terminals or instrument damage may occur.

1. Select the ACV function and 200mV range.
2. Connect the calibrator to the DMM.
3. Set the calibrator output to 100.000mV AC at a frequency of 20Hz. Verify that the reading is within the limits specified in Table 3-3.
4. Repeat the 100mV AC measurement at the other frequencies specified in Table 3-3.
5. Check the 2V, 20V, 200V, and 750V ranges by applying the required voltages and frequencies specified in Table 3-3 and verifying that the readings are within the specified limits.

Table 3-3. Limits for AC Voltage Verification

ACV Range	Applied AC Voltage	Allowable Readings (18°C to 28°C)					
		20Hz	50Hz	10kHz	20kHz	50kHz	100kHz
200 mV	100.000 mV	98.80 to 101.20	99.30 to 100.70	98.10 to 101.90	91.25 to 108.75	—	—
2 V	1.00000 V	0.9880 to 1.0120	0.9930 to 1.0070	0.9860 to 1.0140	0.9675 to 1.0325	0.9300 to 1.0700	—
20 V	10.0000 V	9.880 to 10.120	9.930 to 10.070	9.860 to 10.140	9.675 to 10.325	9.300 to 10.700	—
200 V	100.000 V	98.80 to 101.20	99.30 to 100.70	98.60 to 101.40	96.75 to 103.25	93.00 to 107.00	—
750 V	750.00 V	740.5 to 759.5	744.2 to 755.8	—	—	—	—

3.5.3 Resistance Verification

CAUTION

Do not exceed 450VDC or peak AC between the VOLTS/OHMS/mA and COM terminals or instrument damage may occur.

1. Select the Ω function (AC/DC pushbutton must be out) and the 200 Ω range.
2. Connect the test leads to the Model 175A and short the other ends together.
3. Press the REL pushbutton to compensate for the test lead resistance.
4. Disconnect the short and connect the test leads to the calibrator.
5. Set the calibrator to 100.000 Ω and verify that the reading is within the limits specified in Table 3-4.
6. Check the 2k Ω , 20k Ω , 200k Ω , and M Ω ranges by applying the required resistances specified in Table 3-4 and verifying that the readings are within the specified limits.

Table 3-4. Limits for Resistance Verification

Ω Range	Applied Resistance	Allowable Readings (18°C to 28°C)
200 Ω	100.000 Ω	99.93 to 100.07
2 k Ω	1.00000 k Ω	0.9994 to 1.0006
20 k Ω	10.0000 k Ω	9.993 to 10.007
200 k Ω	100.000 k Ω	99.94 to 100.06
2M Ω	1.00000 M Ω	0.9993 to 1.0007
20M Ω	10.0000 M Ω	9.979 to 10.021

3.5.4 DC Current Verification

CAUTION

Do not exceed 2A to the VOLTS/OHMS/mA and COM terminals or the current fuse will blow.

1. Select the DCA function and, initially, the 2000mA range.
2. Connect the calibrator to the VOLTS/OHMS/mA and COM terminals of the Model 175A.
3. Apply 100.000 μ A and switch the Model 175A to the 200 μ A range. The reading must be within the limits specified in Table 3-5.
4. Check the 2mA through 2000mA ranges by applying the required current specified in Table 3-5 and verifying that the readings are within the specified limits.

CAUTION

Do not exceed 10A continuously or 20A for 15 seconds to the 10 AMP and COM terminals or instrument damage may occur.

5. Set the Model 175A to the 10A range and connect the DC current source to the 10 AMPS and COM terminals.
6. Apply a current of 1.90000A to the Model 175A. The reading must be within the limits specified in Table 3-5.

Table 3-5. Limits for DC Current Verification

DCA Range	Applied DC Current	Allowable Readings (18°C to 28°C)
200 μ A	100.000 μ A	99.83 to 100.17
2 mA	1.00000 mA	0.9983 to 1.0017
20 mA	10.0000 mA	9.983 to 10.017
200 mA	100.000 mA	99.78 to 100.22
2000 mA	1000.00 mA	997.8 to 1002.2
10 A	1.90000 A	1.888 to 1.912

3.5.5 AC Current Verification

Since AC current uses the same circuitry as AC volts and DC current already checked in paragraphs 3.5.2 and 3.5.4, no additional accuracy checks are necessary.

SECTION 4

Principles of Operation

4.1 INTRODUCTION

This section contains an overall functional description of the Model 175A. Information pertaining to the Model 1758 Battery Pack option is also included. Detailed schematics and component location drawings are at the end of this instruction manual.

4.2 OVERALL FUNCTIONAL DESCRIPTION

The Model 175A is a 4-1/2 digit, $\pm 20,000$ count DMM with five AC and DC voltage ranges, seven resistance ranges, and five AC and DC current ranges. A simplified block diagram of the Model 175A is shown in Figure 4-1. The heart of the Model 175A is the A/D converter that translates the conditioned analog input signals into a form usable by the microcomputer.

4.3 ANALOG CIRCUITRY

The following paragraphs contain a description of the input multiplexer, buffer amplifier, $-2V$ reference, and

A/D converter circuits. These circuits may be found on schematic diagram number 175A-106 located at the end of this manual.

4.3.1 Multiplexer

The multiplexer connects one of four signals to the buffer amplifier: signal, zero, ohms reference, or reference. The multiplexer, shown in Figure 4-2, is made up of four JFETS, which are controlled by the microprocessor through U114. The FETs are driven by U109 and part of U106. The drivers convert the digital signals of the microprocessor to signals usable by the FETs.

Ordinarily, FET switching creates transients that could be seen in the final measurement. These effects are minimized in the Model 175A through the use of software generated delays and by shorting the multiplexer bus to signal common before each signal measurement through Q111.

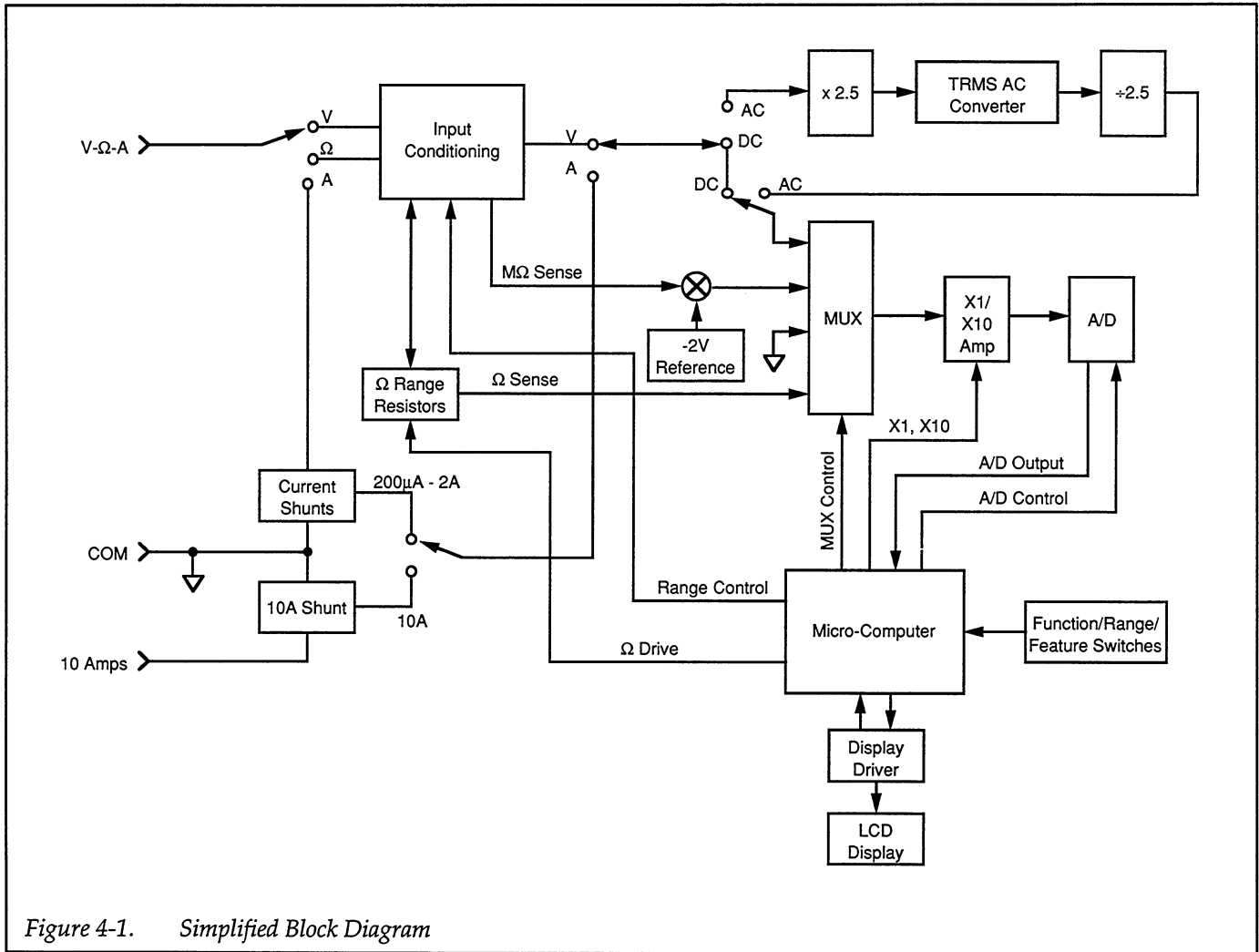

Figure 4-1. Simplified Block Diagram

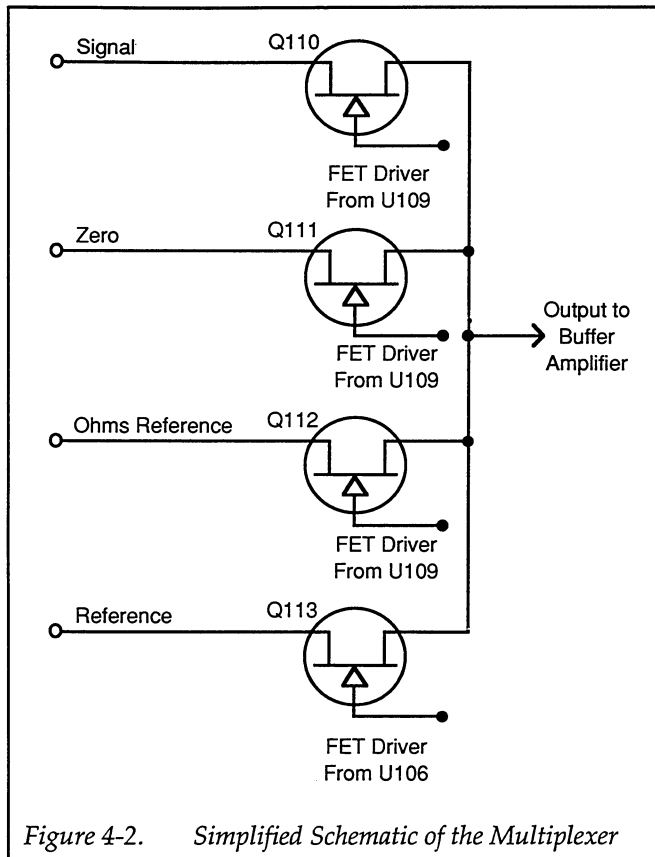

Figure 4-2. Simplified Schematic of the Multiplexer

4.3.2 Input Buffer Amplifier

The input buffer amplifier provides the necessary isolation between the input signal and the A/D converter. The amplifier is a non-inverting, low noise, high impedance circuit with $\times 1$ or $\times 10$ gain. The amplifier gain is controlled by the microprocessor and is range and function dependent. Figure 4-3 shows the simplified schematic of the input buffer amplifier.

4.3.3 -2V Reference Source

The Model 175A voltage and current measurements are based on comparing the unknown signal with an internal -2V reference voltage. During each measurement cycle the microprocessor samples the unknown and uses it along with a zero measurement and -2V signal measurement to compute the unknown voltage.

The -2V reference is made up of a highly stable zener diode (VR101), an op-amp and a resistive voltage divider. U103 and R120 A, B, C act as a constant current source to minimize the zener voltage variations. R117 C, D is then used to divide down the -6.35V zener voltage to -2V.

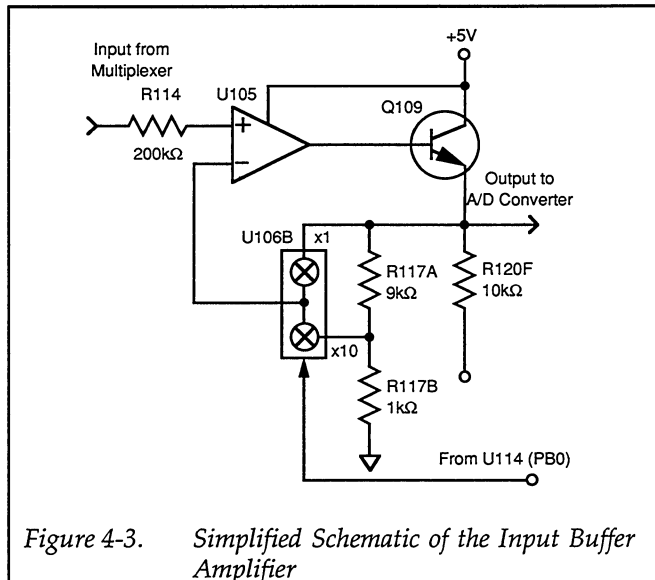

Figure 4-3. Simplified Schematic of the Input Buffer Amplifier

The output of U103 (-7V) is used as a reference voltage for the A/D converter and as a negative supply for various components.

4.3.4 A/D Converter

The Model 175A uses a combination constant frequency charge balance, single slope analog-to-digital converter. A simplified schematic of the A/D used in the Model 175A is shown in Figure 4-4 with an associated output waveform.

The charge balance phase begins when the input enable/disable line is set high. This occurs at the end of a software-generated delay period that allows the signal to settle after the appropriate multiplexer FET is turned on. The actual delay period depends on the selected range and function.

Once this occurs, the signal from the buffer amplifier is added to the offset from R120H. This converts the bipolar signal from the buffer ($\pm 2V$) to a unipolar input to the integrator.

The integrator ramps up until it just passes the charge balance comparator threshold voltage. When the rising edge of Q3 occurs from U122 or when U119 goes low, Q goes high forcing I_{CB} into the integrator input. Since I_{CB} is much greater than the current through R120G and R120H, the integrator output voltage will ramp in the

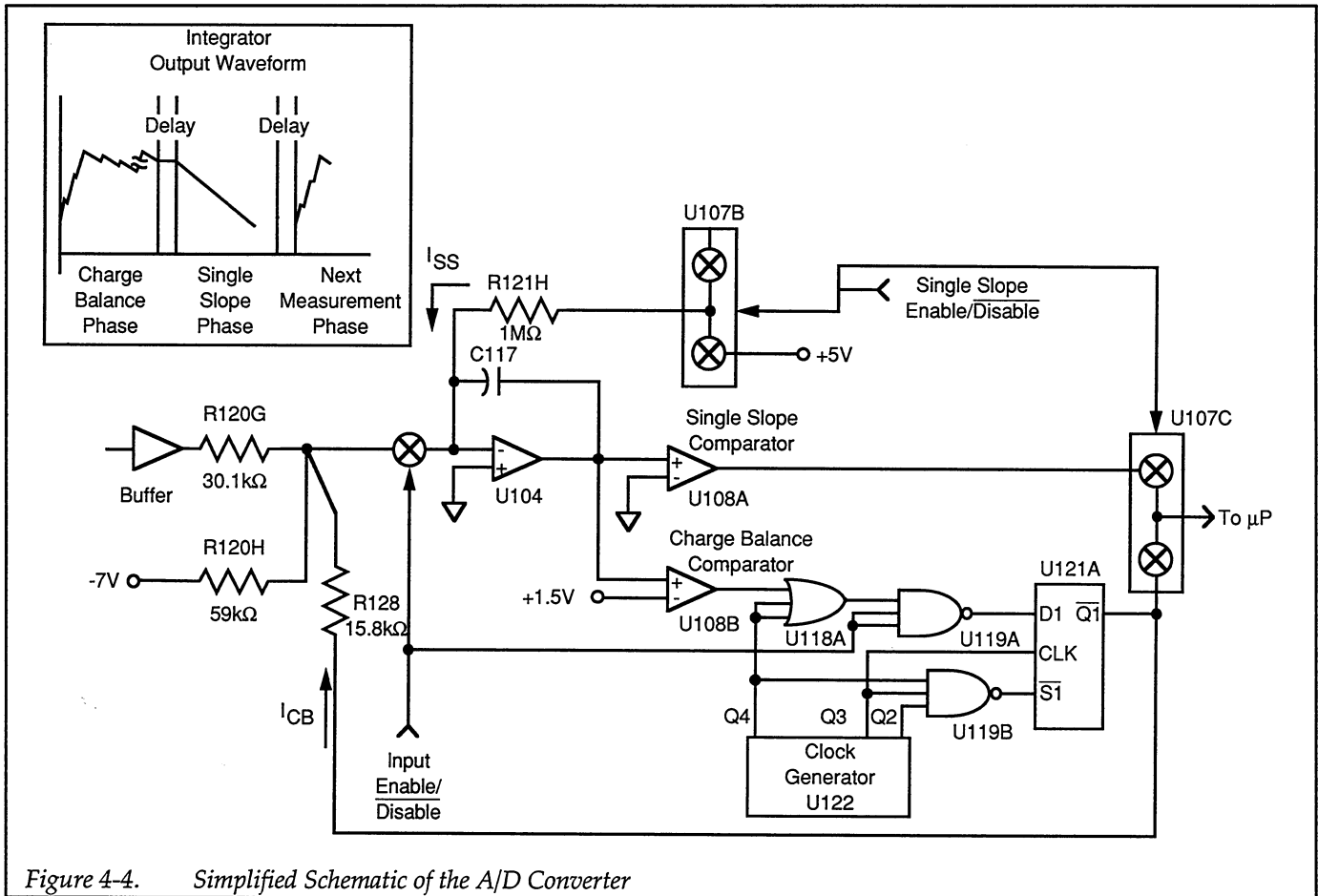

Figure 4-4. Simplified Schematic of the A/D Converter

negative direction. The integrator will continue ramping downward until U119B goes low. Each time the output of U121A goes high, it is gated (inside the microprocessor) with the microprocessor's internal clock and these pulses are counted. Once U121A goes low the process repeats itself.

The charge balance phase continues for 100msec. At the end of the charge balance phase, the output of the integrator is resting at some positive voltage. Since the integrator output is connected to the non-inverting input of U108A, its output will stay high until the integrator ramps negative. During single slope, Q114 is turned off and R121H is connected to +5V. The single slope comparator is then gated with the microprocessor's internal clock and counted. Once the comparator output goes low, the microprocessor stops counting and can compute the reading.

4.3.5 Input Signal Conditioning

For DCV and ACV, the signal conditioning is performed by R106, its shunt capacitors, K101, K102, K103, and Q106.

The following attenuation is provided:

In the DCV mode:

- +1 is used on the 200mV and 2V ranges
- +10 is used on the 20V range
- +100 is used on the 200V range
- +1000 is used on the 1000V range

In the ACV mode:

- +1 is used on the 200mV range
- +10 is used on the 2V range
- +100 is used on the 20V range
- +1000 is used on the 200V and 1000V range

Protection for the AC and DC voltage ranges is provided by R103, R108, Q107, and Q108. R103 and R108 are used exclusively on the lower ranges of ACV and DCV to limit current to Q107 and Q108 during overload. During the overload, Q107 and Q108 clamp the maximum voltage on the signal FET line to within 0.7V of the supplies.

Signal conditioning for current is performed by R109 and R110 current shunts. For DC current measurements, the shunt voltage drop (200mV full scale) is applied directly to the input signal FET for conversion. In AC current, the shunt voltage drop is treated as a 200mV AC signal and is switched to the AC converter section. Overload clamping occurs at three diode voltage drops, which is a level high enough to permit high crest factor current waveforms.

In DCV, the properly scaled signal is applied directly to Q110 through R107 and C110. In the ACV mode, the scaled analog signal is applied to the AC converter for transformation to a DC signal that is applied to Q110.

Resistance measurements are made using the ratiometric technique (see Figure 4-5). When the resistance function is selected, a series circuit is formed among the ohms source, reference resistor, and the external unknown resistance.

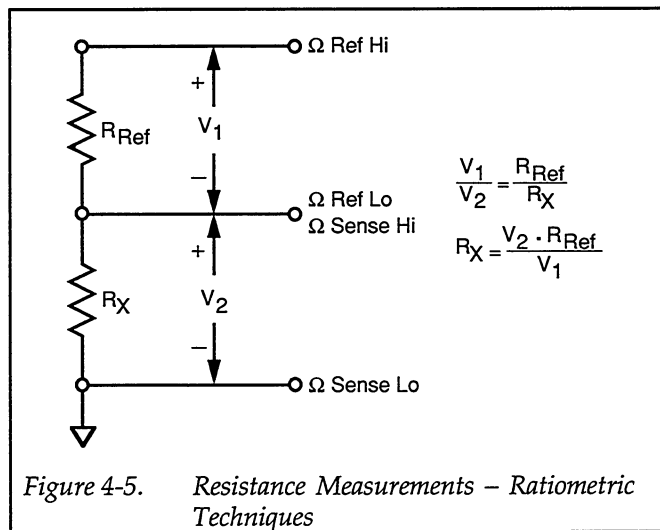

Three reference resistors are used on the ohms ranges: R101, R102, and R106A. R101 is used for the 200Ω and 2kΩ ranges, R102 for the 20kΩ and 200kΩ ranges, and R106A for 2MΩ, 20MΩ, and 200MΩ. Drive for the ohms ranges is ultimately controlled by the microprocessor through U111 and U112.

Switching for the ohms ranges is done using low leakage base to collector diodes of Q102, Q104, and Q105. The appropriate transistor is turned on by driving the base high (+5V). The simplified schematics for the ohms circuitry are shown in Figure 4-6.

By measuring the four inputs to the A/D converter, the unknown resistance can be computed by the microprocessor using the equation:

$$R_X = \frac{\Omega \text{ SENSE HI} - \Omega \text{ SENSE LO}}{\Omega \text{ REF HI} - \Omega \text{ REF LO}}$$

For the 200Ω, 20kΩ, 2MΩ ranges, Ω SENSE HI is actually multiplied by a factor of ten in the buffer circuit.

Protection on the ohms ranges is accomplished by Q103, RT101, Q101, R103, Q107, and Q108. For a voltage applied to the input terminals, Q101 clamps the voltage across R101 to a safe level. RT101 limits current to Q103, which clamps the voltage at Q104 to a safe limit (<12V).

For the 20kΩ and 200kΩ ranges, protection is provided by R102, R104, and R105. R106A provides protection for the 2MΩ, 20MΩ, and 200MΩ ranges by limiting current.

4.3.6 AC Converter

All AC voltage inputs pass through U101 for a ×2.5 voltage amplification. The gain stage is used to permit accurate voltage measurement at higher frequencies and lower input levels.

The output of U101 is applied to the TRMS converter chip (U102), which converts the AC input signal to the corresponding DC level. The DC output is then ÷2.5 and applied to the signal FET.

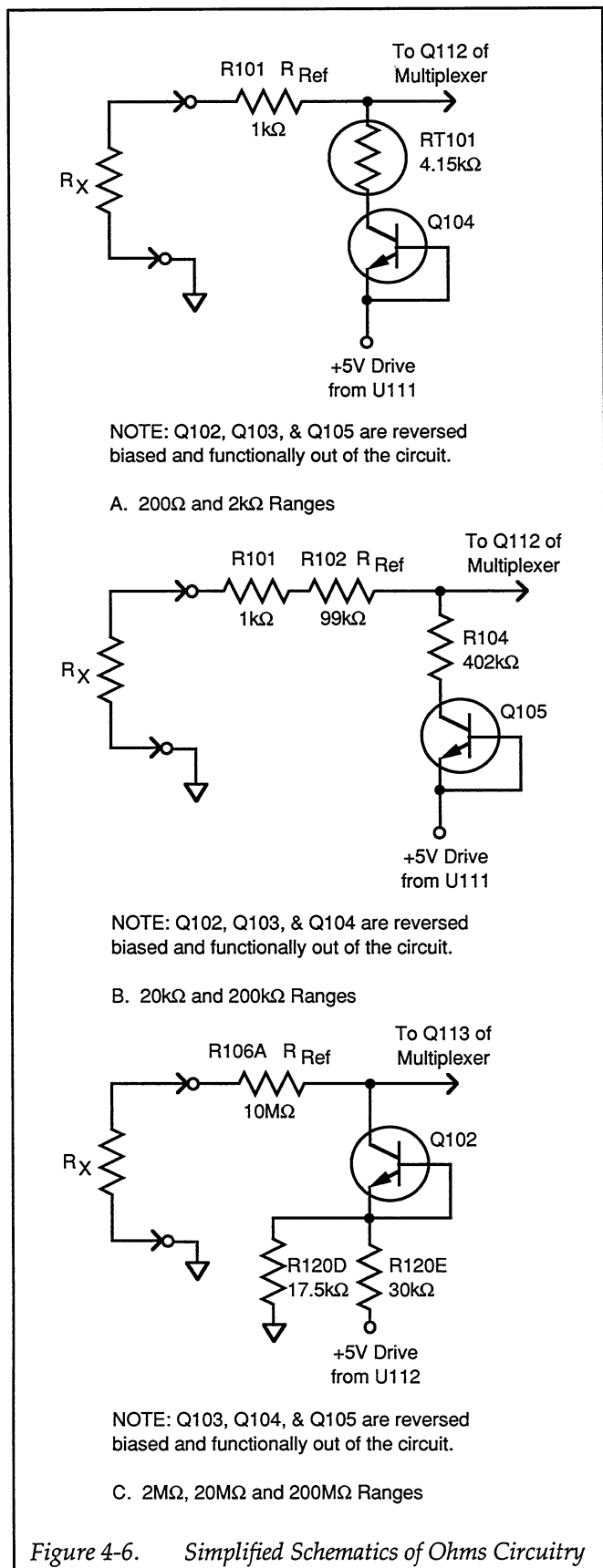

Figure 4-6. Simplified Schematics of Ohms Circuitry

4.4 DIGITAL CIRCUITRY

Model 175A operation is controlled by the internal microcomputer. The following paragraphs briefly describe the operation of the various sections of the microcomputer and associated digital circuitry. A simplified block diagram is included for user reference; for more complete circuit details refer to schematic diagram number 175A-106 at the end of this manual.

4.4.1 Microcomputer

The microcomputer centers around the 146805E2 CMOS microprocessor. It is an 8-bit microprocessor with direct addressing of up to 8K bytes on a shared address and data bus.

Timing of the microprocessor is accomplished by the use of Y101, a 3.2768MHz crystal. Internally, this frequency is divided down by five to obtain a bus operating frequency of 655.36kHz. This is present on the address strobe of U123 (pin 6) and supplies timing to all other parts of the instrument through the binary divider U122.

The software for the microprocessor is stored in U115 (PROM). Temporary storage is provided by U113. U113 is used to share the calibration constants on power-up and as RAM for the microprocessor's in-house functions. It also stores readings for the data logger. U110 is the NVRAM and stores the calibration constants.

4.4.2 Address Decoding

U120 latches in the address that is on the bus when the address strobe of U123 goes high and presents it to the PROM (U115) during data strobe.

4.4.3 PIA

U114 provides for most of the control of the instrument. It controls all ranging hardware, A/D converter, and data output and input for the IEEE-488 option.

4.4.4 Display Board

The LCD display is driven by a flat pack LCD controller chip (U201), which communicates to the microprocessor through four control lines. During power-up, the microprocessor configures U201 to drive the triplexed display.

To drive the display correctly, four voltages are obtained from R126. The clock required by U201 is obtained from U122.

The display board also houses the special function keys: dB, REL, STO/CLR, and RCL.

4.4.5 Display Backlight

The electroluminescent lamp is essentially a capacitor with a phosphor compound between the plates that is excitable by an AC source. U202 is the DC to AC inverter for the backlight and is controlled by switch S104 on the rear panel.

4.5 DIGITAL CALIBRATION

The Model 175A uses digital calibration to eliminate all potentiometers in the instrument to facilitate calibration. The constants that the Model 175A uses are stored in a nonvolatile, electrically alterable, read-only memory (U110), and are read on power-up of the instrument. There is one constant for each range on DCV, ACV, and Ω . On the DCA and ACA functions, the 200mV DC and 200mV AC constants are used respectively.

4.6 POWER SUPPLY

Fuse F102 is the line fuse, which is internally accessible. S101 is the power on/off switch and S102 selects 115V or

230V operation by placing the transformer primary windings in parallel or series.

T101, the power transformer, has two secondary windings: one for the Model 175A and the other for the IEEE-488 option (Model 1753A). The bridge rectifier (CR104) functions as a full-wave rectifier for both the plus and minus supplies. R123 limits current to the 12V zener (VR102) and to the batteries (if installed) for charging. The zener acts as a pre-regulator to the +5V regulator.

4.7 MODEL 1758 BATTERY OPTION

The maximum battery charging rate is achieved when the instrument is connected to line power and the ON/OFF switch is off. Full-wave rectified voltage from CR104 is applied to R102 and BT101 to charge the batteries. Q101 acts as a current sink if the charging current rises above 150mA. The batteries are of the quick recharge type and will charge in 8 to 10 hours. With the instrument turned on, the batteries will trickle charge at approximately 40mA.

With the battery pack installed, the negative supply is generated using a CMOS voltage inverter (U101). The output of the inverter is applied to CR101 and C101 for filtering.

Low battery detection is done by the comparator (U102) and the microprocessor. A voltage level of 8.8V across BT101 signals the end of useful battery life. The trip level for the comparator is set by R103 and R104.

SECTION 5

Maintenance

5.1 INTRODUCTION

This section contains information necessary to maintain, calibrate, and troubleshoot the Model 175A. Line voltage selection, fuse replacement, and Model 1758 Battery Pack installation procedures are also included.

WARNING

The procedures included in this section are for use only by qualified service personnel. Do not perform these procedures unless qualified to do so. Many of the steps in this section may expose you to potentially lethal voltages that could result in personal injury or death if normal safety precautions are not observed.

5.2 DISASSEMBLY INSTRUCTIONS

Use the following disassembly procedure if it is necessary to install an option, replace the line fuse, or troubleshoot the instrument. Disassembly should be done in the order that is presented since, in general, each step depends on previous ones. Most parts referred to are shown in the exploded view of Figure 5-1.

WARNING

Disconnect the line cord and any test leads from the instrument.

Top Cover Removal

1. Turn off the power, disconnect the line cord, and remove all test leads from the terminals of the Model 175A.
2. Turn the unit over and remove the four screws from the bottom of the case.
3. Turn the unit over again and separate the top cover from the rest of the unit.

NOTE

When reinstalling the top cover, make sure to properly position the tilt-bail/handle into the bottom cover.

IEEE-488 Interface Removal (if installed)

The interface board is secured to the mother board by a 6-pin male connector (P1008) and a rear standoff. To remove the interface board, gently lift it upward until it separates from the connector and standoff.

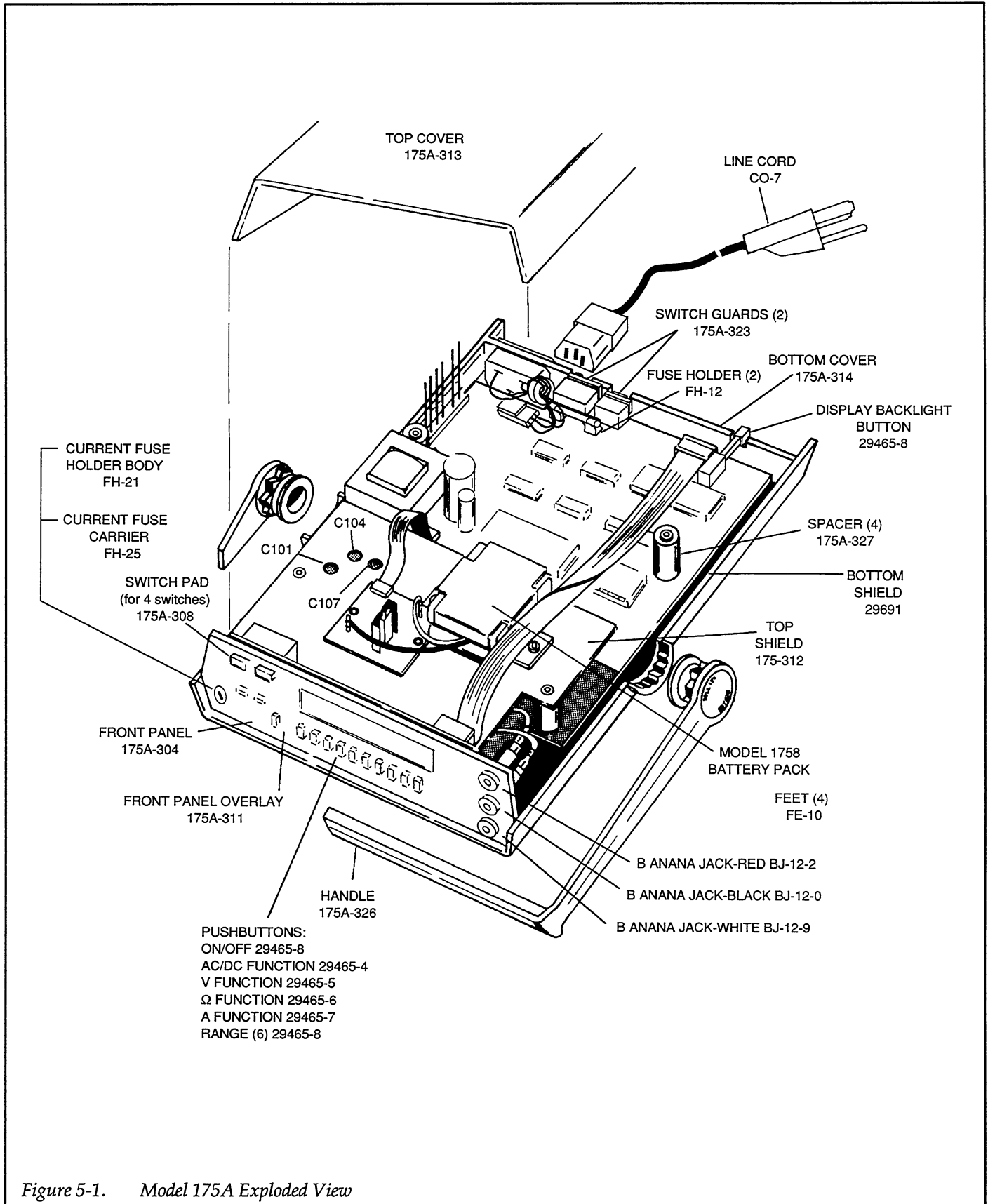

Figure 5-1. Model 175A Exploded View

Battery Pack Removal (if installed)

The Model 1758 battery pack is mounted on top of the mother board top shield. Perform the following steps to remove the complete shield/battery pack assembly:

1. Disconnect the battery pack ribbon cable connector from P1009 on the mother board.
2. Remove the one screw that secures the top shield to the mother board. The screw is located at the rear of the shield.
3. Carefully remove the shield/battery pack assembly from the unit.

Display Board Removal

1. Disconnect the display board ribbon cable from the mother board at J/P1006.
2. Disconnect the input leads from the input jack terminals. Table 5-1 provides terminal identification for reassembly.
3. Remove the front panel assembly from the unit.
4. The display board assembly is secured to the front panel with three screws. Remove these screws and separate the display board assembly from the front panel.

5. The LCD (liquid crystal display) assembly is secured to the display board by five tabs. To remove, gently push the tabs away from the display board and pull the LCD assembly away from the display board. The phosphor layer of the electroluminescent backlight will remain intact with the display board. An exploded view of the display assembly is shown in Figure 5-2.

Table 5-1 Input Terminal Identification

Input Terminal	Conductor Insulator Color
VOLTS/OHMS/mA	Red
COM	Black
10 AMPS	White

Mother board Removal

1. Disconnect the AC power receptacle from the mother board at J/P 1002.
2. Remove the four case spacers.
3. Carefully lift the mother board out of the bottom case cover.

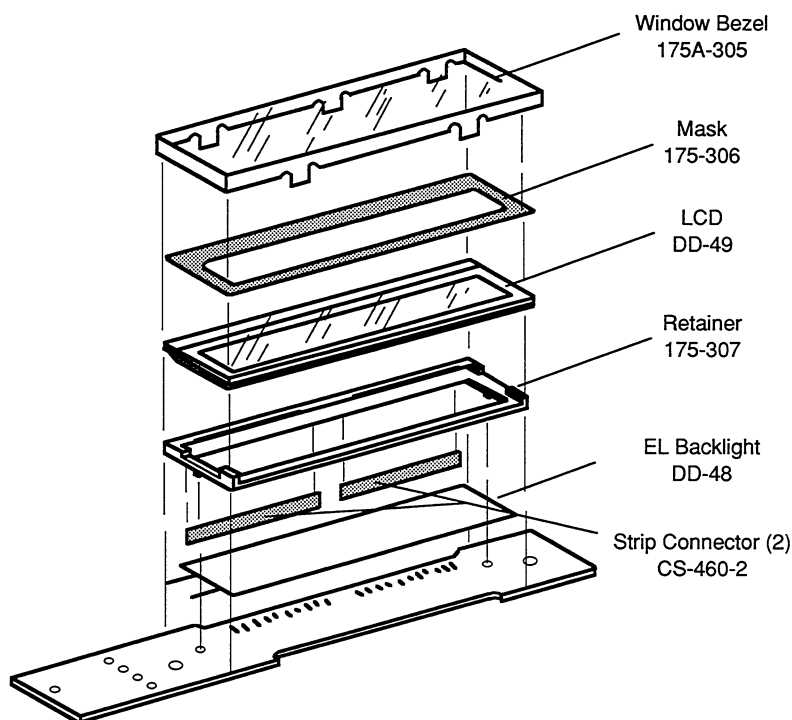

Figure 5-2. Display Assembly

WARNING

When reinstalling the mother board, make sure the two switch guards are installed on the rear panel CALIBRATION and LINE VOLTAGE slide switches. These switch guards block openings in the rear panel, eliminating access to hazardous voltage.

5.3 MODEL 1758 BATTERY PACK INSTALLATION

Refer to Figure 5-1 and perform the following procedure to install the battery pack.

WARNING

Installation of the battery pack should only be performed by qualified personnel. Disconnect the line cord and remove all test leads from the Model 175A.

CAUTION

Do not allow the battery leads to short together or damage to the batteries may occur.

NOTE

It is not recommended that the battery packs be stored at temperatures above 50°C.

1. Remove the top cover as explained in paragraph 5.2.
2. Remove the screw that connects the shield to the PC board. Ease the shield out of the unit.

3. Position the battery board as shown in Figure 5-1 and secure it to the shield using two supplied screws. The screws are fed through the shield into the battery board fasteners.
4. Place the battery pack in the bracket and position it on the shield as shown. Feed the two screws through the shield into the bracket and tighten.
5. Carefully place the shield (with battery pack) back into the Model 175A so that it seats properly on the two spacers. Replace the screw that connects the shield to the PC board.
6. Connect the ribbon cable from the battery board to the male connector (marked BATT.) on the mother board.

CAUTION

Make a close visual inspection to ensure that the connectors are properly mated or damage to the instrument may result.

7. Connect the red battery lead to the +RED terminal pin on the battery board. Connect the black battery lead to the -BLK terminal pin on the battery board.
8. Reinstall the top cover.
9. Charge the battery pack per the instructions in paragraph 2.3.3.

5.4 LINE VOLTAGE SELECTION

The Model 175A may be operated from either 105-125V or 210-250V, 50 or 60Hz power sources. If the line voltage setting of the instrument needs to be changed, set the line voltage switch, located on the rear panel, in the desired position. (See Figure 5-3.)

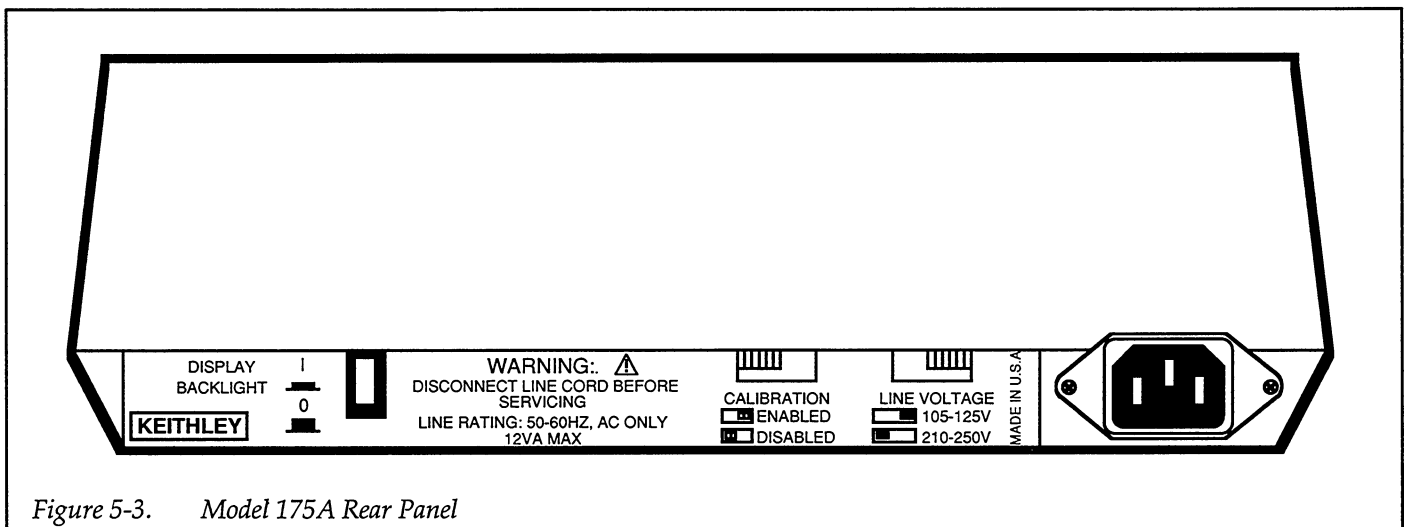

Figure 5-3. Model 175A Rear Panel

WARNING

Disconnect the power cord and all other equipment from the Model 175A.

NOTE

Although the Model 175A is specified at 50 and 60Hz, the instrument may be operated at 400Hz and 440Hz. Add one count to instrument specifications under this condition.

5.5 FUSE REPLACEMENT

The Model 175A has two fuses for protection in case of overload. The current fuse protects the current function from excessive current, and the line fuse protects the line power input of the instrument. The fuses may be replaced by using the procedures found in the following paragraphs.

WARNING

Disconnect the instrument from the power line and from other equipment before replacing fuses.

5.5.1 Current Fuse

The current fuse protects the current ranges from an input greater than 2A. To replace the current fuse, perform the following steps:

1. Turn off the power and disconnect the line cord and all test leads from the instrument.
2. Place the end of a flat-blade screwdriver into the slot in the fuse holder on the front panel. Press in slightly and rotate the fuse carrier one-quarter turn counter-clockwise. Release pressure and remove the fuse carrier and the fuse.
3. Remove the defective fuse and replace it using Table 5-2 as a guide.

CAUTION

Use only the recommended fuse type. If a fuse with a higher current rating is installed, instrument damage may occur.

4. To replace the fuse carrier with the fuse, reverse the procedure in step 2.

Table 5-2. Fuse Replacements

Function	Fuse Type	Keithley Part No.
Current Fuse	2A, 250V, 3AG, Normal-Blo,	FU-13
Line Fuse	1/8A, 250V, 3AG, Slo-Blo	FU-20

5.5.2 Line Fuse

The line fuse is located internally in the Model 175A. For exact fuse location, refer to Figure 5-1.

1. Remove the top cover to gain access to the fuse. If the Model 1753A IEEE-488 interface is installed, it also must be removed. (See paragraph 5.2.)
2. Remove the fuse and replace it with the proper type using Table 5-2 as a guide.

CAUTION

Do not use a fuse with a rating higher than specified or instrument damage may occur. If the instrument repeatedly blows fuses, locate and correct the cause of the trouble before replacing the fuse.

3. Reinstall the IEEE-488 interface, if necessary, and the top cover. (See paragraph 5.2.)

5.6 CALIBRATION

Calibration should be performed every 12 months, or if the performance verification procedures in Section 3 show that the Model 175A is out of specification. If any of the calibration procedures cannot be performed properly, refer to the troubleshooting information in this section. If the problem persists, contact your Keithley representative or the factory for further information.

The entire calibration procedure may be performed without having to make any internal adjustments if frequency compensation has been verified, as explained in paragraph 5.6.8. It is suggested that the 2V, 20V, and 200V ranges at 10kHz be checked (Section 3, Performance Verification) before proceeding.

Calibration can be performed from the front panel or over the IEEE-488 bus. The Model 1755 Calibration Interface can be used for IEEE-488 bus calibration of Model 175A units without installed interfaces.

WARNING

Some procedures require the use of high voltage. Take care to prevent contact with live circuits, which could cause electrical shock resulting in injury or death.

NOTE

Calibration can be stopped at any time and only selected ranges can be calibrated if needed.

NOTE

There is one calibration constant for each range on DCV, ACV, and Ω . On the DCA and ACA functions, the 200mV DC and 200mV AC constants are used, respectively.

5.6.1 Recommended Calibration Equipment

Table 5-3 lists recommended calibration equipment. Alternate equipment may be used as long as equipment accuracy is at least as good as the specifications listed in the table.

5.6.2 Environmental Conditions

Calibration should be performed under laboratory conditions having an ambient temperature of $23 \pm 3^\circ\text{C}$ and a relative humidity of less than 70%.

5.6.3 Warm-Up Period

Turn on the instrument power and allow it warm up for at least one hour before beginning the calibration procedure. If the instrument has been subjected to extremes of temperature or humidity, allow at least one additional hour for the instrument to stabilize before beginning the calibration procedure.

5.6.4 CALIBRATION Switch

The Model 175A is shipped from the factory with its external CALIBRATION switch in the DISABLED position. In this position, calibration constants are not stored in non-volatile memory, when entered from the front panel or over the IEEE-488 bus. The switch must be moved to the ENABLED position to allow calibration constant storage.

The CALIBRATION switch is shown in Figure 5-3. Slide the switch to ENABLED. Turn the instrument off, then on, and press in the REL and dB pushbuttons simultaneously until the message "CAL" is displayed. Release the buttons. The unit is now in the calibration mode as indicated by the "C" annunciator.

Table 5-3. Recommended Calibration Equipment

Description	Specifications	Manufacturer and Model
DC Voltage Calibrator	200mV, 2V, 20V, 200V, 1100V ranges, $\pm 0.005\%$ accuracy.	Fluke 5101B
AC Voltage Calibrator	200mV, 2V, 20V, 200V, 1100V ranges, $\pm 0.05\%$ accuracy.	Fluke 5101B
Resistance Calibrator	100 Ω , 1k Ω , 10k Ω , 100k Ω ranges, $\pm 0.005\%$; 1M Ω range, $\pm 0.01\%$; 10M Ω range, $\pm 0.05\%$	Fluke 5101B

5.6.5 DC Voltage Calibration From Front Panel

Connect the calibration source to the VOLTS/OHMS/mA and COM terminals of the Model 175A.

1. Ensure that the Model 175A is in the calibration mode ("C" annunciator on), as explained in paragraph 5.6.4.
2. Select the 200mV DC range on the Model 175A.
3. Set the voltage calibrator to output 0V.
4. Press the REL button (REL on).
5. Set the voltage calibrator output (+190.000mV for the 200mV range, see Table 5-4 for other ranges).
6. Adjust the Model 175A displayed reading (190.00mV for the 200mV range, also see Table 5-4) with the use of the STO/CLR and RCL buttons. The STO/CLR button increments the displayed reading; the RCL button decrements the displayed reading.
7. Select the next DC voltage range on the Model 175A.
8. Repeat steps 3 through 7 for the remaining ranges, calibrator voltages, and readings as listed in Table 5-4.

Table 5-4. DC Voltage Calibration

175A Range	Calibrator Voltage	175A Reading
200 mV	190.000 mV	190.00 mV
2 V	1.90000 V	1.9000 V
20 V	19.00000 V	19.0000 V
200 V	190.00000 V	190.0000 V
1000 V	1000.00000 V	1000.0000 V

5.6.6 AC Voltage Calibration From Front Panel

With the Model 175A still in the calibration mode ("C" annunciator on), select the AC volts function and connect the calibrator to the VOLTS/OHMS/mA and COM terminals of the Model 175A. Steps 1 through 6 must be performed in the exact sequence listed.

1. Select the 200mV range and set the calibrator to output 190.000mV @ 200Hz.
2. Adjust the Model 175A display using the STO/CLR and RCL buttons to read 190.00mV AC.
3. Press the dB button and verify that the dB annunciator is on.
4. Set the calibrator to output 19.00000mV @ 200Hz.
5. Adjust the display to read 19.00mV.

6. Press the REL button and verify that the dB annunciator is off.
7. Repeat only steps 1 and 2 for the remaining ranges using Table 5-5 as a guide.

Table 5-5. AC Voltage Calibration

175A Range	Calibrator Voltage	Calibrator Frequency	175A Reading
200 mV	190.000 mV	200Hz	190.00 mV
200 mV*	19.00000 mV	200Hz	19.000 mV
2 V	1.900000 V	200Hz	1.90000 V
20 V	19.00000 V	200Hz	19.0000 V
200 V	190.00000 V	200Hz	190.0000 V
750 V	750.00000 V	200Hz	750.0000 V

*dB annunciator must be on (indicated two-point calibration).

5.6.7 Resistance Calibration From Front Panel

With the Model 175A still in the calibration mode ("C" annunciator on), select the Ω function and connect the test leads to the VOLTS/OHMS/mA and COM terminals of the Model 175A. Table 5-6 summarizes the procedure.

1. With the test leads connected to the Model 175A, short the other ends together.
2. Select the 200 Ω range and press the REL button on the Model 175A. The REL annunciator will turn on and the display will zero (test lead compensation).
3. Disconnect the short and connect the test leads to the calibrator.
4. Set the calibrator to output 100 Ω and adjust the Model 175A display, using the STO/CLR and RCL buttons for a reading of 100.00 Ω .
5. Press the REL button and note that the REL annunciator turns off.
6. Select the 2k Ω range and again short the test leads together.
7. Press the REL button. The REL annunciator will turn on and the display will zero.
8. Reconnect the test leads, set the calibrator to output 1k Ω , and adjust the Model 175A for a reading of 1.0000k Ω .
9. Press the REL button to turn off REL.
10. Select the 20k Ω range and set the calibrator to output 10k Ω . Adjust the Model 175A to read 10.000k Ω .
11. Repeat step 8 for the 200k Ω , 2M Ω and 20M Ω ranges using Table 5-6 as a guide.

Table 5-6. Resistance Calibration

175A Range	REL*	Calibration Resistance	175A Reading
200 Ω	on	100 Ω	100.00 Ω
2 kΩ	on	1 kΩ	1.0000 kΩ
20 kΩ	off	10 kΩ	10.000 kΩ
200 kΩ	off	100 kΩ	100.00 kΩ
2 MΩ	off	1 MΩ	1.0000 MΩ
20 MΩ	off	10 MΩ	10.000 MΩ

*REL is used to compensate for test lead resistance on the 200Ω and 2kΩ ranges.

5.6.8 Frequency Compensation

Check high frequency (10kHz) AC volts accuracy as explained in Section 3, Performance Verification. In the event that frequency compensation must be performed, three internal trimmer capacitors will have to be adjusted. When making adjustments use a flat-bladed, insulated calibration tool.

The trimmer capacitors are accessible through the shield (see Figure 5-1). Once the top cover is removed, as described in paragraph 5.2, the shield and PC board must be secured to the bottom cover to prevent movement. This assembly can be secured with two screws and nuts in place of the top cover. Proceed as follows:

1. Set the Model 175A for 200VAC and set the calibrator to output 100.000V @ 10kHz.
2. Adjust C101 for a reading of 100.00 ±3 counts.
3. Select the 2V range and set the calibrator to output 1.00000V @ 10kHz.
4. Adjust C104 for a reading of 1.0000 ±8 counts.
5. Repeat steps 1 and 2.
6. Select the 20V range and set the calibrator to output 10.0000V @ 10kHz.
7. Adjust C107 for a reading of 10.000 ±8 counts.

5.6.9 Calibration Storage

To store the calibration constants, simultaneously press the REL and dB buttons until the message "Stor" is displayed.

If instead the message "out" is displayed, then calibration storage was not enabled and the calibration constants will only be valid until the Model 175A is turned off.

To save the calibration constants after "out" appears on the display, slide the CALIBRATION switch to ENABLED. Press REL and dB simultaneously until "CAL" appears on the display. Then simultaneously press REL and dB until "Stor" is displayed. The calibration constants are now stored in non-volatile memory.

Slide the CALIBRATION switch back to the DISABLED position.

5.6.10 IEEE-488 Bus Calibration

The Model 175A, with the Model 1753A installed, can be calibrated over the IEEE-488 bus with the use of a programmable calibrator and a controller.

The example program at the end of this section can be used to calibrate the Model 175A over the IEEE-488 bus. Use the equipment listed below:

- Keithley Model 1753A IEEE-488 Interface
- Fluke Model 5100 Series B Calibrator with Model 5100A-05 IEEE-488 Interface.
- Hewlett-Packard Model HP-85 Computer with the following:
 1. Model HP 82937A HP-IB Interface
 2. Model HP 82936A ROM Drawer
 3. I/O ROM (0085-15003)

The example calibration program is written in HP-85 BASIC. The syntax used by other Hewlett-packard computers running under BASIC 2.0 or BASIC 4.0 is very similar. However, there are a few differences between these programming languages, as indicated in Table 5-7.

Detailed operating instructions for the Model 1753A bus interface can be found in the Model 1753A Instruction Manual.

Table 5-7. HP-85 and BASIC 2.0/4.0 Programming Language Differences

HP-85 Statement	BASIC 2.0 (4.0) Equivalent Statement(s)	Comments
CLEAR	C\$=CHR\$(255) & CHR\$(75) H\$=CHR\$(255) & CHR\$(84) OUTPUT KBD; C\$; H\$	Clear screen, home cursor
DISP	PRINT	Display variables or literals on CRT
ENABLE INTR 7; 8	ENABLE INTR 7; 2	Enable SRQ interrupt
STATUS 7, 1; S	STATUS 7, 5; S	Clear SRQ interrupt
DISP "MESSAGE", INPUT A\$	INPUT "MESSAGE", A\$	Prompt for and input variable
IF ... THEN ... ELSE ...	IF ... THEN ELSE END IF	Conditional branching
ABORTIO 7	ABORT 7	Send IFC

Programming Example

Use the following procedure, along with the equipment listed previously, to calibrate a Model 175A over the IEEE-488 bus.

1. Place the rear panel CALIBRATION switch in the ENABLED position and enter calibration mode as described in paragraph 5.6.4.
2. Configure the Model 175A/1753A, HP-85, and the Model 5100 Calibrator as a system by connecting the instruments together with IEEE-488 cables.
3. Set the primary address of the Model 175A/1753A to 24 (11000). Set the Model 5100 Calibrator to 17 (10001).
4. Turn the instruments on and allow a one hour warm-up.
5. Type the program listed at the end of this section into the HP-85.
6. After step 5 is complete, check the program to make sure there are no mistakes. If the program has even a small mistake it will not operate as intended.
7. Connect the output of the Model 5100 Calibrator to VOLTS/OHMS/mA and COM terminals of the Model 175A.
8. Press the RUN key on the HP-85 to initiate the program.
9. The program will stop at certain pre-determined points to prompt the user to change functions. When the prompt instructions have been completed, press CONT on the HP-85 to resume the program.
10. When the "calibration is now complete" message is displayed, slide the CALIBRATION switch back to the DISABLED position.

5.7 TROUBLESHOOTING

The troubleshooting information contained in this section is intended for use by qualified personnel having a basic understanding of analog and digital circuitry. The individual should also be experienced at using typical test equipment as well as ordinary troubleshooting procedures.

The information presented here has been written to assist in isolating a defective circuit or circuit section. Isolation of the specific component is left to the technician. Note that schematic diagrams and component location drawings, which are an essential aid in troubleshooting, are located at the end of Section 6.

NOTE

Avoid touching the PC board or its component parts. Handle the PC board by its edges.

5.7.1 Recommended Test Equipment

Success in troubleshooting instruments like the Model 175A depends not only on the skill of the technician, but relies on the use of accurate, reliable test equipment. Table 5-8 lists the equipment recommended for troubleshooting the Model 175A. Other equipment, such as logic analyzers and capacitance meters, could also be helpful, especially in difficult situations.

Table 5-8. Recommended Troubleshooting Equipment

Equipment	Use
Five-function DMM with 0.05% basic DC accuracy, 10MΩ input impedance.	Power supply and DC voltage checks, analog signal tracing, continuity, static logic levels.
Dual-trace, triggered-sweep oscilloscope, DC to 50MHz bandwidth.	Digital and analog waveform checks.

5.7.2 Self Diagnostic Program

To use the self diagnostic program, hold in the dB button and turn on the Model 175A. The following will occur:

1. All LCD digits and annunciators will turn on.
2. The software revision level will be displayed (e.g., A1).
3. The sequential display test will run.
4. The Model 175A will go into the troubleshooting test mode.

If the dB button is released, the instrument will flag either RAM or NVRAM self test failures, should they occur. If neither RAM nor NVRAM fails, the instrument will default to the troubleshooting test mode.

RAM Test

If the RAM test fails, the Model 175A will lock up with all zeros displayed. Replacing U113 may correct problem.

Non-volatile RAM Test

If the NVRAM test fails, the following message will be displayed:

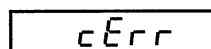

This message indicates that the instrument is probably not properly calibrated, since calibration constants are stored in the non-volatile RAM. The Model 175A will

lock up at this point if the test fails, but operation may be restored for troubleshooting by pressing any front panel control button. The flashing "C" annunciator will indicate that the unit failed the NVRAM test.

At this point, try calibrating the instrument with the constants already entered by simultaneously pressing in REL and dB until "CAL" is displayed, and then again until "Stor" is displayed. If the error gets corrected, indicating that the NVRAM is probably good, a full calibration will be needed. If the error persists, try replacing the NVRAM chip (U110). Again, the Model 175A must undergo a complete calibration after the problem is corrected.

Sequential Display Test

Segments and annunciators are sequentially displayed in eight steps. Use Figure 5-4 for segment identification. The steps are as listed in Table 5-9.

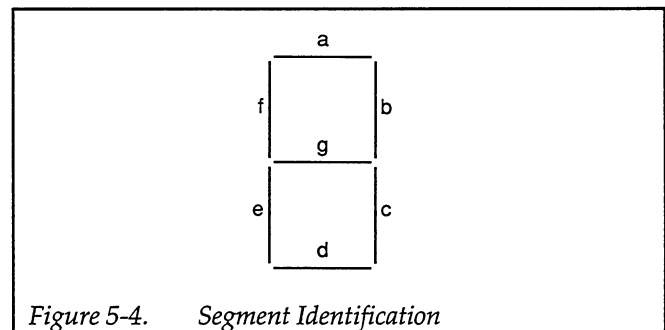

Troubleshooting Test Modes

The troubleshooting mode is designed to switch on various switching FETs, transistors, and logic levels to allow signal tracing through the instrument. The first displayed mode will reflect the selected function and range. For example, assume that "0u1" is displayed. The "0" is the test number, the "u" corresponds to the volts function, and the "1" corresponds to the 200mV range. The test number can be changed by pressing in the dB button. Table 5-10 lists the test modes for all functions and ranges.

To update the test mode, select the new function and range and hold in the dB button until the function symbol changes.

Troubleshooting consists of selecting the desired test mode and using the data found in Table 5-10 to signal trace the circuit.

Table 5-9. Sequential Display Test Steps

Step	Segment of Digits	Annunciators
1	a	dB, V
2	b	none
3	c	none
4	d	m (mA), RCL, RMT
5	e	minus sign, REL, M, Ω
6	f	AUTO, BAT, m (mV), C
7	g	AC, k
8	none	decimal points, most significant digit, STO, μ , A

Notes:

1. When a different function or range is selected, the dB button must be pressed and held in to update the display with the corresponding test mode.
2. Do not use AUTO when in AC or DC volts.
3. Use AUTO when checking circuitry on the 20M Ω and 200M Ω ranges (Xo6).

Table 5-10. Troubleshooting Modes

Function & Range	Test Mode	AMP Gain (U105*)	Multiplexer FET On	Ohms Range Transistor On	Range Control Logic level on U114			
					PA0	PA1	PA2	PA3
200mVDC	0u1	x10	Q110		1	1	1	1
	1u1	x10	Q111		1	1	1	1
	2u1	x1	Q113		1	1	1	1
	3u1	x1	Q111		1	1	1	1
2VDC	0u2	x1	Q110		1	1	1	1
	1u2	x1	Q111		1	1	1	1
	2u2	x1	Q113		1	1	1	1
	3u2	x1	Q111		1	1	1	1
20VDC	0u3	x1	Q110		1	0	1	1
	1u3	x1	Q111		1	0	1	1
	2u3	x1	Q113		1	0	1	1
	3u3	x1	Q111		1	0	1	1
200VDC	0u4	x1	Q110		1	0	0	1
	1u4	x1	Q111		1	0	0	1
	2u4	x1	Q113		1	0	0	1
	3u4	x1	Q111		1	0	0	1
1000VDC	0u5	x1	Q110		0	0	1	1
	1u5	x1	Q111		0	0	1	1
	2u5	x1	Q113		0	0	1	1
	3u5	x1	Q111		0	0	1	1
200mVAC	0u1	x10	Q110		1	1	1	1
	1u1	x10	Q111		1	1	1	1
	2u1	x1	Q113		1	1	1	1
	3u1	x1	Q111		1	1	1	1
2VAC	0u2	x10	Q110		1	0	1	1
	1u2	x10	Q111		1	0	1	1
	2u2	x1	Q113		1	0	1	1
	3u2	x1	Q111		1	0	1	1
20VAC	0u3	x10	Q110		1	0	0	1
	1u3	x10	Q111		1	0	0	1
	2u3	x1	Q113		1	0	0	1
	3u3	x1	Q111		1	0	0	1
200VAC	0u4	x10	Q110		1	0	1	1
	1u4	x10	Q111		1	0	1	1
	2u4	x1	Q113		1	0	1	1
	3u4	x1	Q111		1	0	1	1
750VAC	0u5	x10	Q110		0	0	1	1
	1u5	x10	Q111		0	0	1	1
	2u5	x1	Q113		0	0	1	1
	3u5	x1	Q111		0	0	1	1
ACA & DCA ALL Ranges	0A1-0A6	x10	Q110		0	0	0	1
	1A1-1A6	x10	Q111		0	0	0	1
	2A1-2A6	x1	Q113		0	0	0	1
	3A1-3A6	x1	Q111		0	0	0	1

Troubleshooting Modes (Cont.)

Function & Range	Test Mode	AMP Gain (U105*)	Multiplexer FET On	Ohms Range Transistor On	Range Control Logic level on U114			
					PA0	PA1	PA2	PA3
200 Ω	0o1	x10	Q110	Q104	1	1	1	0
	1o1	x10	Q111	Q104	1	1	1	0
	2o1	x1	Q112	Q104	1	1	1	0
	3o1	x1	Q110	Q104	1	1	1	0
	4o1							
	5o1	x1	Q111	Q104	1	1	1	0
	6o1	x1	Q113	Q104	1	1	1	0
2k Ω	0o2	x1	Q110	Q104	1	1	1	0
	1o2	x1	Q111	Q104	1	1	1	0
	2o2	x1	Q112	Q104	1	1	1	0
	3o2	x1	Q110	Q104	1	1	1	0
	4o2							
	5o2	x1	Q111	Q104	1	1	1	0
	6o2	x1	Q113	Q104	1	1	1	0
20k Ω	0o3	x10	Q110	Q105	0	1	1	1
	1o3	x10	Q111	Q105	0	1	1	1
	2o3	x1	Q112	Q105	0	1	1	1
	3o3	x1	Q110	Q105	0	1	1	1
	4o3							
	5o3	x1	Q111	Q105	0	1	1	1
	6o3	x1	Q113	Q105	0	1	1	1
200k Ω	0o4	x1	Q110	Q105	0	1	1	1
	1o4	x1	Q111	Q105	0	1	1	1
	2o4	x1	Q112	Q105	0	1	1	1
	3o4	x1	Q110	Q105	0	1	1	1
	4o4							
	5o4	x1	Q111	Q105	0	1	1	1
	6o4	x1	Q113	Q105	0	1	1	1
2M Ω (M Ω)	0o5	x10	Q110	Q102	1	1	0	1
	1o5	x10	Q111	Q102	1	1	0	1
	2o5	x1	Q113	Q102	1	1	0	1
	3o5	x1	Q110	Q102	1	1	0	1
	4o5							
	5o5	x1	Q111	Q102	1	1	0	1
	6o5	x1	Q113	Q102	1	1	0	1
20 & 200M Ω (M Ω)	0o6	x1	Q110	Q102	1	1	0	1
	1o6	x1	Q111	Q102	1	1	0	1
	2o6	x1	Q113	Q102	1	1	0	1
	3o6							
	4o6							
	5o6	x1	Q111	Q102	1	1	0	1
	6o6	x1	Q113	Q102	1	1	0	1

*+4 to 5V (Logic 1) at pin 9 of U106B selects x10 gain, 0V (Logic 0) at pin 9 of U106B selects x1 gain.

5.7.3 Power Supply and Battery Pack (Model 1758) Checks

Table 5-11 shows the various checks that can be made to the power supplies within the Models 175A and 1758. In addition to the normal voltage checks, it is a good idea to check the various supplies with an oscilloscope to make sure no noise or ringing are present.

5.7.4 A/D Converter and Display

Make sure the A/D converter and display are operating properly before attempting to troubleshoot the signal conditioning circuits. Check these circuits using the information in Tables 5-11 and 5-12.

5.7.5 Signal Conditioning

These circuits can be checked by using the diagnostic program (troubleshooting modes). See paragraph 5.7.2.

5.8 SPECIAL HANDLING OF STATIC SENSITIVE DEVICES

CMOS devices operate at very high impedance levels for low power consumption. As a result, any static charge that builds up on your person or clothing may be suffi-

cient to destroy these devices, if they are not handled properly.

CAUTION

Since the many CMOS devices installed in the Model 175A are not denoted in this manual, all ICs and transistors should be handled as static-sensitive devices.

When handling these devices, use the following precautions to avoid damaging them:

1. Transport such devices only in containers designed to prevent static build-up. Typically, these parts will be received in anti-static containers of plastic or foam. Always leave the devices in question in their original containers until ready for installation.
2. Remove the devices from their protective containers only at a properly grounded work station. Also ground yourself with a suitable wrist strap.
3. Handle the devices only by the body; do not touch the pins or terminals.
4. Any printed circuit board into which the device is to be inserted must also be properly grounded to the bench or table.
5. Use only anti-static type de-soldering tools.
6. Use only soldering irons with properly grounded tips.
7. Once the device is installed on the PC board, it is usually adequately protected, and normal handling can resume.

Table 5-11. Power Supply Checks and Battery Pack (Model 1758) Checks

Step	Item/Component	Required Condition	Remarks
1	S102 Line Switch	Set to 115 or 230V as required.	S102 externally accessible from rear panel.
2	F102 Line Fuse	Continuity.	
3	Line Cord	Plugged into line receptacle; power on.	
4	U116** Input (Vin)	+12V \pm 10%	+5V regulator input.
5	U116** Output (Vo)	+5V \pm 5%	+5V regulator output.
6	U117 Input (Vin)	-20V to -14V	Negative supply input.
7	U117 Output (Vo)	-10V \pm 10%	Negative supply output.
8	VR101	-6.25V to -6.45V	Reference zener diode.
9	U103 pin 6	-7V \pm 5%	Low noise negative supply.
10*	Q101 base	0.6V while charging (power switch off)	Current sink.
11*		Line cord disconnected, battery pack charged, power switch on.	
12*	U101 pin 8	>8.8V	Voltage inverter.
13*	U102 pin 7	+5V with batteries charged.	Voltage comparator.

*Checks for the Model 1758

**If U116 is replaced, be sure that the device is properly seated on the mother board so that it will not touch the IEEE board (if installed).

Table 5-12. A/D Converter Checks

Step	Item/Component	Required Condition	Remarks
1		Turn on power; select 2V DC range. Short input.	
2	U123, pin 38	3.2768MHz clock	Crystal (Y101)
3	U122, pin 10	655.36kHz clock	Address strobe
4	U122, pin 6	81.92kHz clock	Synchronous clock for A/D
5	U122, pin 5	40.96kHz clock	Synchronous clock for A/D
6	U122, pin 7	163.84kHz clock	Synchronous clock for A/D
7	U122, pin 12	1.28kHz clock	Integrator timebase and real time interrupt.
8	U119B, pin 6	+5V to \approx 0V pulse train, 3 μ sec duration every 22 μ sec	Charge balance synchronization signal.
9	U104, pin 6	Integrator Ramp	
10	U108, pin 6	\approx 1.5V	Comparator reference
11	U108B, pin 7	Variable pulse train 0V to +5V.	Comparator output
12	U121A, pin 6	Variable pulse train, 0V to +5V.	Reference current generator
13	U107A, pin 15	Variable pulse train, 0V to +5V.	
14	U107A, pin 10	\approx 5msec positive going pulses.	Control line for charge balance/single slope.
15	U121B, pin 9	100msec positive going pulse.	Control line for integrator

Table 5-13. Display Board Checks

Step	Item/Component	Required Condition	Remarks
1		Turn on power; select the 2VDC range.	
2	P1006, pin 6	+3.33V	Vlcd1
3	P1006, pin 7	+1.66V	Vlcd2
4	P1006, pin 8	+5V \pm 5%	Power to display
5	P1006, pin 3	81.92kHz	clock.
6	P1006, pin 2	0V to +5V pulses	Data from microprocessor
7	P1006, pin 13	0V to +5V pulses	Data from microprocessor
8	P1006, pin 14	0V to +5V pulses	Data from microprocessor
9	P1006, pin 15	+5V to 0V pulses	Data from microprocessor
10	P1006, pin 1	+4.7V, backlight on	
11	LCD	Check that LCD is positioned properly.	
12	Connector (P1006)	Check that connector is not reversed. If reversed, display test will run, then display will blank.	
13	Strip Connectors	Check that they are positioned properly.	

Note: There is a twist in the cable to mate pin 1 of P1006 to pin 1 of the socket on the mother board.

PROGRAM	COMMENTS
10 REMOTE 724, 717	
20 CLEAR	
30 DISP " "	
40 DISP "THIS PROGRAM RUNS A FULL CALI BRATION ON THE MODEL 175A USING THE FLUKE MODEL 5101B"	
50 DISP " "	
60 DISP "PRESS CONT TO RESUME PROGRAM"	
70 PAUSE	
80 CLEAR	
90 DISP " "	
100 DISP "SELECT THE DCV FUNCTION AND CON NECT THE CALIBRATION SOURCE"	DC VOLTS CALIBRATION
110 DISP " "	
120 DISP " "	
130 DISP "PRESS CONT TO RESUME PROGRAM"	
140 DISP " "	
150 PAUSE	
160 OUTPUT 724; "R1X"	Sets 175A to 200mV range.
170 OUTPUT 717; "0V,N"	Outputs 0V to 175A.
180 WAIT 1000	
185 OUTPUT 724; "V.1X"	Put 175A in CAL mode.
190 OUTPUT 724; "Z1X"	Turns REL on.
200 WAIT 1000	
210 OUTPUT 717; ".19V,N"	Outputs 190mV to 175A.
220 WAIT 5000	
230 OUTPUT 724; "V.19X"	Calibrates 200mV range.
240 WAIT 2000	
250 OUTPUT 724; "R2X"	Sets 175A to 2V range.
260 OUTPUT 717; "0V,N"	Outputs 0V to 175A.
270 WAIT 1000	
280 OUTPUT 724; "Z1X"	Turns REL on.
290 WAIT 1000	
300 OUTPUT 717; "1.9V, N"	Outputs 1.9V to 175A.
310 WAIT 5000	
320 OUTPUT 724; "V1.9X"	Calibrates 2V range.
330 WAIT 2000	
340 OUTPUT 724; "R3X"	Sets 175A to 20V range.
342 OUTPUT 717; "0V,N"	Outputs 0V to 175A.
344 WAIT 1000	
346 OUTPUT 724; "Z1X"	Turns REL on.
348 WAIT 1000	
350 OUTPUT 717; "19V,N"	Outputs 19V to 175A.
360 WAIT 5000	
370 OUTPUT 724; "V19X"	Calibrates 20V range.
380 WAIT 2000	
390 OUTPUT 717; "S"	Sets 5101B to standby.
400 OUTPUT 724; "R4X"	Sets 175A to 200V range.
410 CLEAR	
420 BEEP 50, 1000	
430 DISP " "	

PROGRAM	COMMENTS
440 DISP "WARNING! THE FOLLOWING STEPS USE HIGH VOLTAGE!"	
450 DISP " "	
460 DISP "PRESS CONT TO RESUME PROGRAM"	
470 DISP " "	
480 PAUSE	
490 DISP " "	
492 OUTPUT 717; "0V,N"	Outputs 0V to 175A.
494 WAIT 1000	
496 OUTPUT 724; "Z1X"	Turns REL on.
498 WAIT 1000	
500 OUTPUT 717; "190V,N"	Outputs 190V to 175A.
510 WAIT 5000	
520 OUTPUT 724; "V190X"	Calibrates 200V range.
530 WAIT 2000	
540 OUTPUT 724; "R5X"	Sets 175A to 1000V range.
542 OUTPUT 717; "0V,N"	Outputs 0V to 175A.
544 WAIT 1000	
546 OUTPUT 724; "Z1X"	Turns REL on.
548 WAIT 1000	
550 OUTPUT 717; "1000V,N"	Outputs 1000V to 175A.
560 WAIT 5000	
570 OUTPUT 724; "V1000X"	Calibrates 1000V range.
580 WAIT 2000	
590 OUTPUT 717; "S"	Sets 5101B to standby.
600 CLEAR	
610 BEEP 50, 1000	
620 DISP " "	
630 DISP "DC VOLTS CALIBRATION IS NOW COMPLETE"	
640 DISP " "	
650 DISP "SELECT AC VOLTS and ..."	AC VOLTS CALIBRATION
660 WAIT 2000	
670 DISP " "	
680 DISP "PRESS CONT TO RESUME PROGRAM"	
690 PAUSE	
700 OUTPUT 724; "R1X"	Sets 175A to 200mV range.
710 OUTPUT 717; ".19V200H,N"	Outputs 190mV at 200Hz to 175A.
720 WAIT 5000	
730 OUTPUT 724; "V.19X"	Calibrates high end of 200mV range.
740 WAIT 2000	
750 OUTPUT 724; "D1X"	Turns dB annunciator on.
760 OUTPUT 717; "19E-3V200H,N"	Outputs 19mV at 200Hz to 175A.
770 WAIT 5000	
780 OUTPUT 724; "V19E-3X"	Calibrates low end of 200mV range.
790 WAIT 2000	
800 OUTPUT 724; "Z0X"	Turns dB annunciator off.
810 WAIT 5000	
820 OUTPUT 724; "R2X"	Sets 175A to 2V range.
830 OUTPUT 717; "1.9V200H,N"	Outputs 1.9V at 200Hz to 175A.
840 WAIT 5000	
850 OUTPUT 724; "V1.9X"	Calibrates 2V range.
860 WAIT 2000	

PROGRAM	COMMENTS
870 OUTPUT 724;"R3X"	Sets 175A to 20V range.
880 OUTPUT 717;"19V200H,N"	Outputs 19V at 200Hz to 175A.
890 WAIT 5000	
900 OUTPUT 724;"V19X"	Calibrates 20V range.
910 WAIT 2000	
920 OUTPUT 717;"S"	Sets 5101B to standby.
930 OUTPUT 724;"R4X"	Sets 175A to 200V range.
940 CLEAR	
950 BEEP 50, 1000	
960 DISP " "	
970 DISP "WARNING! THE NEXT STEPS USE HIGH VOLTAGE!"	
980 DISP " "	
990 DISP "PRESS CONT TO RESUME PROGRAM"	
1000 PAUSE	
1010 OUTPUT 717;"190V200H,N"	Outputs 190V at 200Hz to 175A.
1020 WAIT 5000	
1030 OUTPUT 724;"V190X"	Calibrates 200V range.
1040 WAIT 2000	
1050 OUTPUT 717;"S"	Sets 5101B to standby.
1060 OUTPUT 724;"R5X"	Sets 175A to 750V range.
1070 OUTPUT 717;"750V400H,N"	Outputs 750V at 400Hz to 175A.
1080 WAIT 5000	
1090 OUTPUT 724;"V750X"	Calibrates 750V range.
1100 WAIT 2000	
1110 OUTPUT 717;"S"	Sets 5101B to standby.
1120 CLEAR	
1130 BEEP 50, 1000	
1140 DISP " "	
1150 DISP "AC VOLTS CALIBRATION IS COMPLETE"	
1160 WAIT 2000	
1170 DISP " "	
1180 DISP "SELECT OHMS and REMEMBER TO RELEASE THE AC BUTTON"	OHMS CALIBRATION
1190 WAIT 2000	
1200 DISP " "	
1210 DISP "PRESS CONT TO RESUME PROGRAM"	
1220 PAUSE	
1230 CLEAR	
1240 OUTPUT 724;"R1X"	Sets 175A to 200Ω range.
1250 FOR H=0 TO 1	Sets program for one loop.
1260 GOTO 1270	
1270 OUTPUT 717;"1Z,N"	Outputs 1Ω to 175A.
1280 WAIT 5000	
1290 ENTER 724; D	Enter displayed reading (D).
1300 A=D-1	A = Test lead resistance and cal error.
1310 OUTPUT 717;"100Z,N"	Output 100Ω to 175A.
1320 WAIT 5000	
1330 B=100	B = 100Ω from 5101B.
1340 F=B+A	F = Cal point plus lead resistance and cal error.
1350 C\$="V"&VAL\$(F)&"X"	C\$ = Command that calibrates 175A using F.
1360 OUTPUT 724; C\$	Calibrate 200Ω range.

PROGRAM	COMMENTS
1370 WAIT 2000	
1380 NEXT H	Loops to line 1250 once.
1390 OUTPUT 724; "R2X"	Sets 175A to 2k Ω range.
1400 FOR H=0 TO 1	Sets program for one loop.
1410 GOTO 1420	
1420 OUTPUT 717; "1Z,N"	Outputs 1 Ω to 175A.
1430 WAIT 5000	
1440 ENTER 724; D	Enter displayed reading (B).
1450 A=D-1	A = Test lead resistance and cal error.
1460 OUTPUT 717; "1E3Z,N"	Output 1k Ω to 175A.
1470 WAIT 5000	
1480 B=1000	B = 1000 Ω from 5101B.
1490 F=B+A	F = Cal points plus lead resistance and cal error.
1500 C\$="V"&VAL\$(F)&"X"	C\$ = Command that calibrates 175A using F.
1510 OUTPUT 724; C\$	Calibrates 2k Ω range.
1520 WAIT 2000	
1530 NEXT H	Loops to line 1400 once.
1540 OUTPUT 724; "R3X"	Sets 175A to 20k Ω range.
1550 OUTPUT 717; "10E3Z,N"	Outputs 10k Ω to 175A.
1560 WAIT 5000	
1570 OUTPUT 724; "V10E3X"	Calibrates 20k Ω range.
1580 WAIT 2000	
1590 OUTPUT 724; "R4X"	Sets 175A to 200k Ω range.
1600 OUTPUT 717; "100E3Z, N"	Outputs 100k Ω to 175A.
1610 WAIT 5000	
1620 OUTPUT 724; "V100E3X"	Calibrates 200k Ω range.
1630 WAIT 2000	
1640 OUTPUT 724; "R5X"	Sets 175A to M Ω ranges.
1650 OUTPUT 717; "1E6Z,N"	Outputs 1M Ω to 175A.
1660 WAIT 5000	
1670 OUTPUT 724; "V1E6X"	Calibrates 2M Ω range.
1680 WAIT 2000	
1690 OUTPUT 717; "10E6Z,N"	Outputs 10M Ω to 175A.
1700 WAIT 5000	
1710 OUTPUT 724; "V10E6X"	Calibrates 20M Ω range.
1720 WAIT 2000	
1730 BEEP 50, 1000	
1740 DISP "CAL POINTS ARE NOW ENTERED"	
1750 WAIT 1000	
1760 DISP " "	
1770 DISP "DO YOU WISH TO STORE CAL POINTS IN NVRAM?"	
1780 WAIT 1000	
1790 DISP " "	
1800 DISP "IF YES, PRESS Y and END LINE"	
1810 DISP "IF NO, PRESS N and END LINE"	
1820 INPUT A\$	
1830 IF A\$="Y" THEN 1850	
1840 IF A\$="N" THEN 1910	
1850 OUTPUT 724; "L0X"	Stores calibration points in NVRAM.
1860 WAIT 2000	

SECTION 5
Maintenance

PROGRAM	COMMENTS
1870 FOR I=1 TO 25	
1880 BEEP I*RND+1, 50	
1890 NEXT I	
1900 BEEP 40, 3000	
1910 "DISP "*****"	
1920 DISP "THE MODEL 175A CALIBRATION IS NOW COMPLETE."	
1930 "DISP "*****"	
1940 END	

SECTION 6

Replaceable Parts

6.1 INTRODUCTION

This section contains replacement parts information, component location drawings, and schematic diagrams for the Model 175A.

6.2 PARTS LIST

Parts are listed alphanumerically in order of their circuit designations. Table 6-1 contains parts list information for the Model 175A. Table 6-2 contains information for miscellaneous parts not called out in Figures 5-1 and 5-2. Table 6-3 contains a parts list for the Model 1758 Battery Pack.

6.3 ORDERING INFORMATION

To place an order, or to obtain information concerning replacement parts, contact your Keithley representative or the factory. See inside front cover for addresses. When ordering, include the following information:

- Instrument model number

- Instrument serial number
- Parts description
- Circuit designation (if applicable)
- Keithley part number

If an additional instruction manual is required, order the manual package (Keithley part number 175A-901-00). The manual package contains an instruction manual and any applicable addenda.

6.4 FACTORY SERVICE

If the instrument is to be returned to the factory for service, please complete the service form, which follows this section, and return it with the instrument.

6.5 SCHEMATIC DIAGRAMS AND COMPONENT LOCATION DRAWINGS

Schematic diagrams and component location drawings follow the parts lists.

TABLE 6-1. MODEL 175A PARTS LIST

Circuit Design.	Description	Keithley Part No.
C101	CAPACITOR	C-184
C102	CAPACITOR	C-349-6.2P
C103	CAP,15PF,5%,100V,CERAMIC	C-372-15P
C104	CAP, 3-10PF, 500V VARIABLE	C-346
C105	CAP, 8200PF, 1%,50V, CERAMIC	C-347-8200P
C106	CAPACITOR, CERAMIC	C-316-.02
C107	CAP, 7-70PF, 500V VARIABLE	C-345
C108	CAP,710PF,2%,50V,CERAMIC	C-348-710P
C109	CAPACITOR	C-360-.01
C110,117	CAP, .01UF, 10%,100V POLYPROPYLENE	C-306-.01
C111	CAP, 1UF, 20%,50V POLYESTER	C-350-1
C112	CAP, 15UF, 10%,20V TANTALUM	C-204-15
C113,123	CAP,1UF,20%,50V, CERAMIC	C-237-1
C114,124,127..131	CAP,.1UF,20%,50V,CERAMIC	C-237-.1
C115	CAP, 2UF,10%,100V POLYESTER	C-294-2
C116	CAP, 10UF,-20+100%,25V,ALUM ELEC	C-314-10
C118	CAP,1500UF,-20,+100%,25V,ALUM ELEC	C-314-1500
C119,120,122	CAP,4.7UF,-20+100%,25V,ALUM ELEC	C-314-4.7
C121	CAP,220UF,-20+100%,25V,ALUM ELEC	C-314-220
C125,126	CAP,22PF,10%,1000V,CERAMIC	C-64-22P
C133	CAP, 1PF, 25%, 1000V CERAMIC	C-367-1P
C201	CAP,470UF,20%,6.3V, ALUM ELEC	C-445-470
CR102	DIODE,BRIDGE,KBP02 (CASE KBP)	RF-36
CR103	DIODE	RF-34
CR104	DIODE,BRIDGE,VM18	RF-52
DS202	ELECTROLUMINESCENT PANEL	DD-48
F101	FUSE, 2A/3AG	FU-13
F102	FUSE, .125A, 250V,3AG SLO-BLO	FU-20
J1001	A.C. RECEPTACLE	CS-254
J1006	16-PIN SOCKET (FOR DISPLAY CABLE)	SO-65
J1009	CONN,DUAL 5-PIN-BERG	CS-389-4
K101	RELAY, (SPST)	RL-82
K102,103	RELAY, REED (SPST)	RL-59
P1002	CONN, MALE, MODIFIED	175-316
P1006	16 CONDUCTOR CABLE ASSEMBLY	CA-30-5
P1008	CONN, IEEE, MODIFIED	175-321
Q101,Q109	TRANS,NPN SILICON,2N3904 (TO-92)	TG-47
Q102,Q115	TRANS,NPN COMP SILICON AMP,2N5089	TG-62-1
Q103	TRANS,NPN SILICON,5818 (TO-92)	TG-138-1
Q104,105,107,108	TG-62 SELECTION	175-601
Q106	TRANS,P CHANNEL JFET,J270 (TO-92)	TG-166

Q110,Q111,Q112,Q113 Q114	TRANS,N CHANNEL JFET,SELECTED J210 TRANS,N CHANNEL FET,2N4392 (TO-92)	TG-167-1 TG-128-1
R101	RES, 1K,1%,1/8W METAL FILM	R-177-1K
R102	RES, 99K,1%,1/8W METAL FILM	R-177-99K
R103	RES, 220K, 10%, 1W COMPOSITION	R-2-220K
R104	RESISTOR, CARBON COMP	R-12-402K
R105	RES,1M,5%,1/4W, COMPOSITION OR FILM	R-76-1M
R106	THICK FILM	TF-170
R107	RES, 390K, 5%, 1/4W, COMPOSITION OR FILM	R-76-390K
R108	RESISTOR	R-320-43K
R109	RES NET, 900 90,9, 10%	TF-168-1
R110	RESISTOR	R-318
R111	RES,10K,5%,1/4W,COMPOSITION OR FILM	R-76-10K
R112	RES, 2.5K, .1%, 1/8W METAL FILM	R-176-2.5K
R113	RES, 1.6K,.1%,1/8W, METAL FILM	R-176-1.6K
R114,R129,R130	RES,200K,5%,1/4W,COMPOSITION OR FILM	R-76-200K
R115	RES,100K,.1%,1/8W,METAL FILM,T2	R-176-100K
R116	RES, 64K, .1%, 1/8W METAL FILM	R-176-64K
R117	THICK FILM	TF-169
R118	RES,3.3K,5%,1/4W, COMPOSITION OR FILM	R-76-3.3K
R119	RES, .01, .25%, 1W, WIREWOUND	R-388-.01
R120	THICK FILM	TF-171
R121	THICK FILM	TF-172
R123	RES, 22, 10%, 2W COMPOSITION	R-3-22
R124	RES, 8.06K, 1%, 1/8W, METAL FILM	R-88-8.06K
R125	RES,1.24K,1%,1/8W,METAL FILM	R-88-1.24K
R126	THICK FILM	TF-173
R127	RES,10M,5%,1/4W,COMPOSITION OR FILM	R-76-10M
R128	RES,2.2K,5%,1/4W,COMPOSITION OR FILM	R-76-2.2K
R131	RES,10,5%,1/4W,COMPOSITION OR FILM	R-76-10
R132,133	RES,1K,5%,1/4W,COMPOSITION OR FILM	R-76-1K
R134	RES, 22K 5%, 1/4W, COMPOSITION OR FILM	R-76-22K
R135	RES,47K,5%,1/4W,COMPOSITION OR FILM	R-76-47K
R136	RES,2K,5%,1/4,COMPOSITION OR FILM	R-76-2K
R139	RES, 100M, .5%,1/4W METAL OXIDE	R-269-100M
RT101	THERMISTOR	RT-9-1
S101	SWITCH	SW-448
S102	SWITCH, SLIDE (DPDT)	SW-318
S103	SWITCH, SLIDE (4PDT)	SW-465
S104	SWITCH, PUSHBUTTON (FOR DISPLAY BACKLIGHT)	SW-410
T101	TRANSFORMER	TR-201
U101	IC, WIRE BAND JFET INPUT OP-AMP, 4	IC-248-1
U102	IC, TRMS TO DC CONVERTER, 637	IC-352
U103	IC, 18V OP-AMP, TLC 271	IC-347-1
U104	IC, 18V OP-AMP, TL061	IC-227
U105	IC-347 SELECTION	175-600
U106,U107,U109	IC,TRIPLE 2 CH MULTI/DEMUX,4053	IC-283-1
U108	IC, DUAL COMP,LM393	IC-343
U110	IC, 16X16 BIT SERIAL RAM, X2443P	IC-353

U111	IC,HEX INVERTER,74HC04	IC-354
U112	IC,QUAD 2 INPUT NAND,74HC00	IC-351
U113	LARGE SCALE IC, 1024 X 4 STATIC CMOS ROM	LSI-62
U114	IC, PERIPHERAL INTERFACE ADAPTER, 65C21	LSI-61
U115	IC, (8K X 8) UV ERASABLE PROM, 27C64	175A-800-*
U116	IC,+5V VOLTAGE REGULATOR, 7805	IC-93
U117	IC, 3-TERM, ADJUST, REGULATOR, LM337L	IC-345
U118	IC, TRIPLE 3-ONPUT OR, CD4075BE	IC-143
U119	IC, TRIPLE 3 INPUT NAND, 74HC10	IC-341
U120	IC, OCTAL D-LATCH W/3 STATE OUT, 7	IC-338
U121	IC,DUAL D-TYPE FLIP FLOP,74HC74	IC-337
U122	IC, 12-STAGE BINARY COUNTER, 4040B	IC-348
U123	IC, CMOS 8 BIT MICROPROCESSOR, 146	LSI-60
U124	IC,SUPPLY VOLTAGE SUPERVISOR,TL7705AC	IC-602
U201	IC, LCD CONTROLLER/DRIVER, 7225	LSI-59
U202	MODULE, INVERTER	MO-31-1
VR101	DIODE,ZENER 6.44V,IN4577AGED (DO-7)	DZ-58
VR102	DIODE, ZENER 12V, IN5349B (CASE 17)	DZ-72-1
VR103	DIODE, ZENER 5.1V,IN751(DO-7)	DZ-59
VR104	DIODE, ZENER, 12V,IN9638	DZ-54
W1	JUMPER,CIRCUIT	J-3
Y101	CRYSTAL, 3.276800MHZ	CR-21

*Order same software as presently installed. For example, if A01 is the displayed software, order 175A-800-A01.

TABLE 6-2. MODEL 175A MISCELLANEOUS PARTS LIST

Circuit Desig.	Description	Keithley Part No.
	CONNECTOR (FOR CO-7)	CS-276
	CONNECTOR, HOUSING	CS-287-3
	DISPLAY BD ASSY TO FRONT PANEL	4-40X1/4
	FOOT, BLACK MOLDED POLY	FE-12
	GROUND CONTACT	26533
	LABEL, INSTRUCTION	MC-587
	LABEL, REAR	MC-583
	LABEL, TRANSFORMER	MC-221
	TEST LEADS	CA-22
	40-PIN SOCKET (FOR U114)	SO-84-40
	40-PIN SOCKET (FOR U123)	SO-84-40
	28-PIN SOCKET (FOR U115)	SO-69

