

Section 7

DIAGRAMS AND SCHEMATICS

Symbols and Reference Designators

Electrical components shown on the diagrams are in the following units unless noted otherwise:

Capacitors = Values one or greater are in picofarads (pF).
 Values less than one are in microfarads (μ F).

Resistors = Ohms (Ω).

Graphic symbols and class designation letters are based on ANSI Standard Y32.2-1975.

Logic symbology is based on ANSI Y32.14-1973 in terms of positive logic. Logic symbols depict the logic function performed and may differ from the manufacturer's data.

Abbreviations are based on ANSI Y1.1-1972. Other ANSI standards that are used in the preparation of diagrams by Tektronix, Inc., are:

- Y14.15, 1966 Drafting Practices.
- Y14.2, 1973 Line Conventions and Lettering.
- Y10.5, 1968 Letter Symbols for Quantities Used in Electrical Science and Electrical Engineering.

The following prefix letters are used as reference designators to identify components or assemblies on the diagrams.

A	Assembly, separable or repairable (circuit board, etc.)	H	Heat dissipating device (heat sink, heat radiator, etc.)	S	Switch or contactor
AT	Attenuator, fixed or variable	HR	Heater	T	Transformer
B	Motor	HY	Hybrid circuit	TC	Thermocouple
BT	Battery	J	Connector, stationary portion	TP	Test point
C	Capacitor, fixed or variable	K	Relay	U	Assembly, inseparable or non-repairable (integrated circuit, etc.)
CB	Circuit breaker	L	Inductor, fixed or variable	V	Electron tube
CR	Diode, signal or rectifier	M	Meter	VR	Voltage regulator (zener diode, etc.)
DL	Delay line	P	Connector, movable portion	W	Wirestrap or cable
DS	Indicating device (lamp)	Q	Transistor or silicon-controlled rectifier	Y	Crystal
E	Spark Gap, Ferrite bead	R	Resistor, fixed or variable	Z	Phase shifter
F	Fuse	RT	Thermistor		
FL	Filter				

The following special symbols may appear on the diagrams:

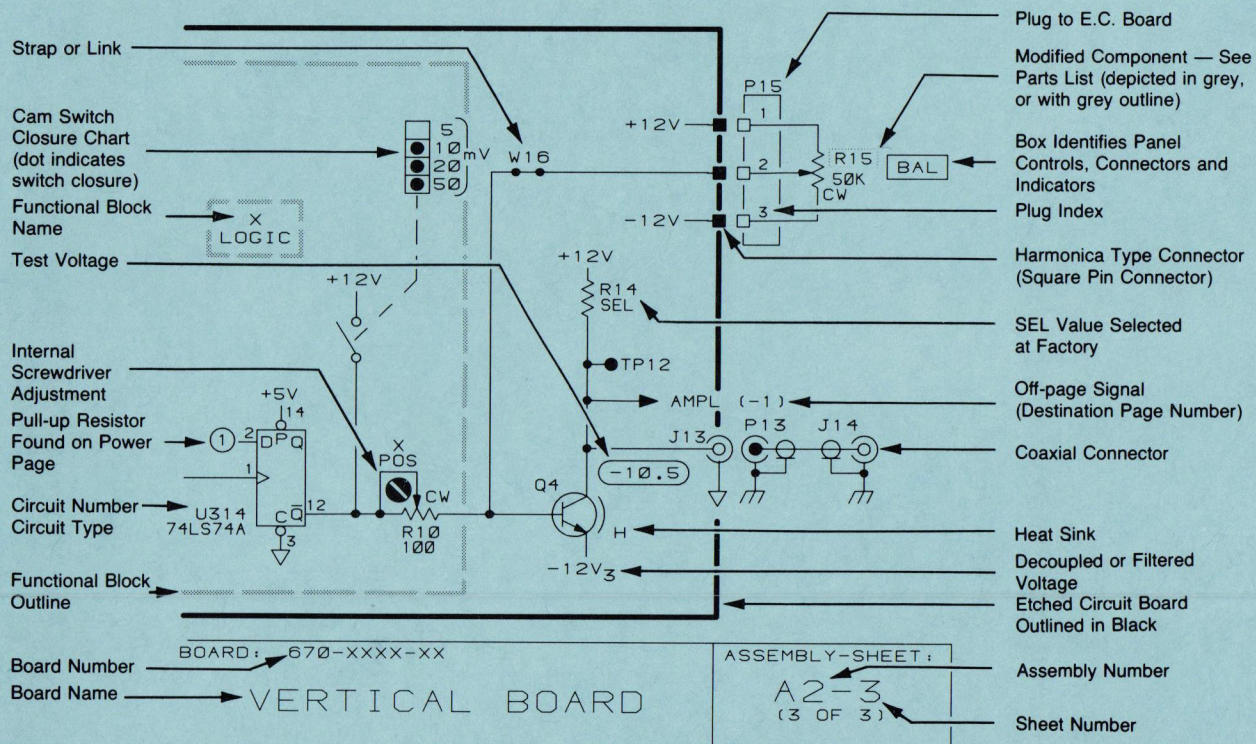

1. True High and True Low Signals

Signal names on the schematics are followed by -1 or a -0. A TRUE HIGH signal is indicated by -1, and a TRUE LOW signal is indicated by -0.

SIGNAL -1 = TRUE HIGH
SIGNAL -0 = TRUE LOW

2. Cross-References

Schematic cross-references (from/to information) are included on the schematics. The "from" reference only indicates the signal "source," and the "to" reference lists all loads where the signal is used. All from/to information will be enclosed in parentheses.

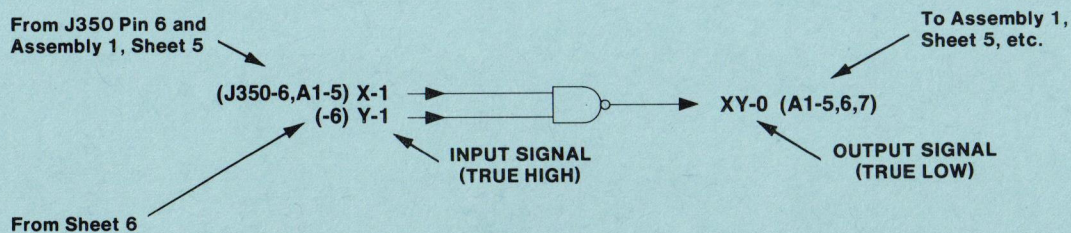

3. Component Number Example

COMPONENT NUMBER EXAMPLE

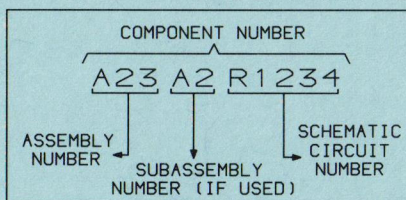

CHASSIS-MOUNTED COMPONENTS HAVE NO ASSEMBLY NUMBER
PREFIX—SEE END OF REPLACEABLE ELECTRICAL PARTS LIST.

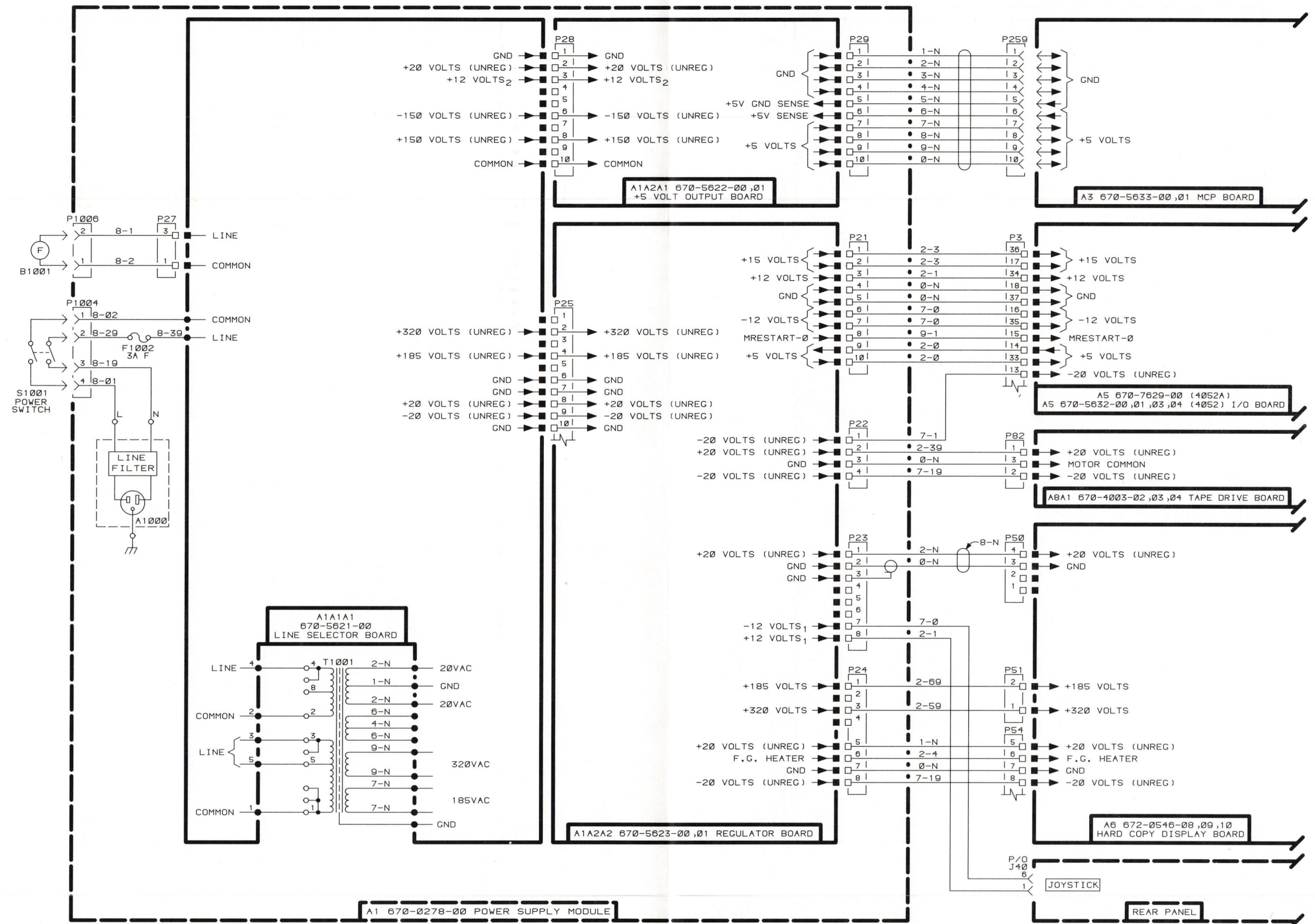

INSTRUMENT:
4052/4052A

NOTES:

2829-11

DIAGRAM:
SYSTEM INTERCONNECT
POWER SUPPLY

SHEET:
1 OF 7

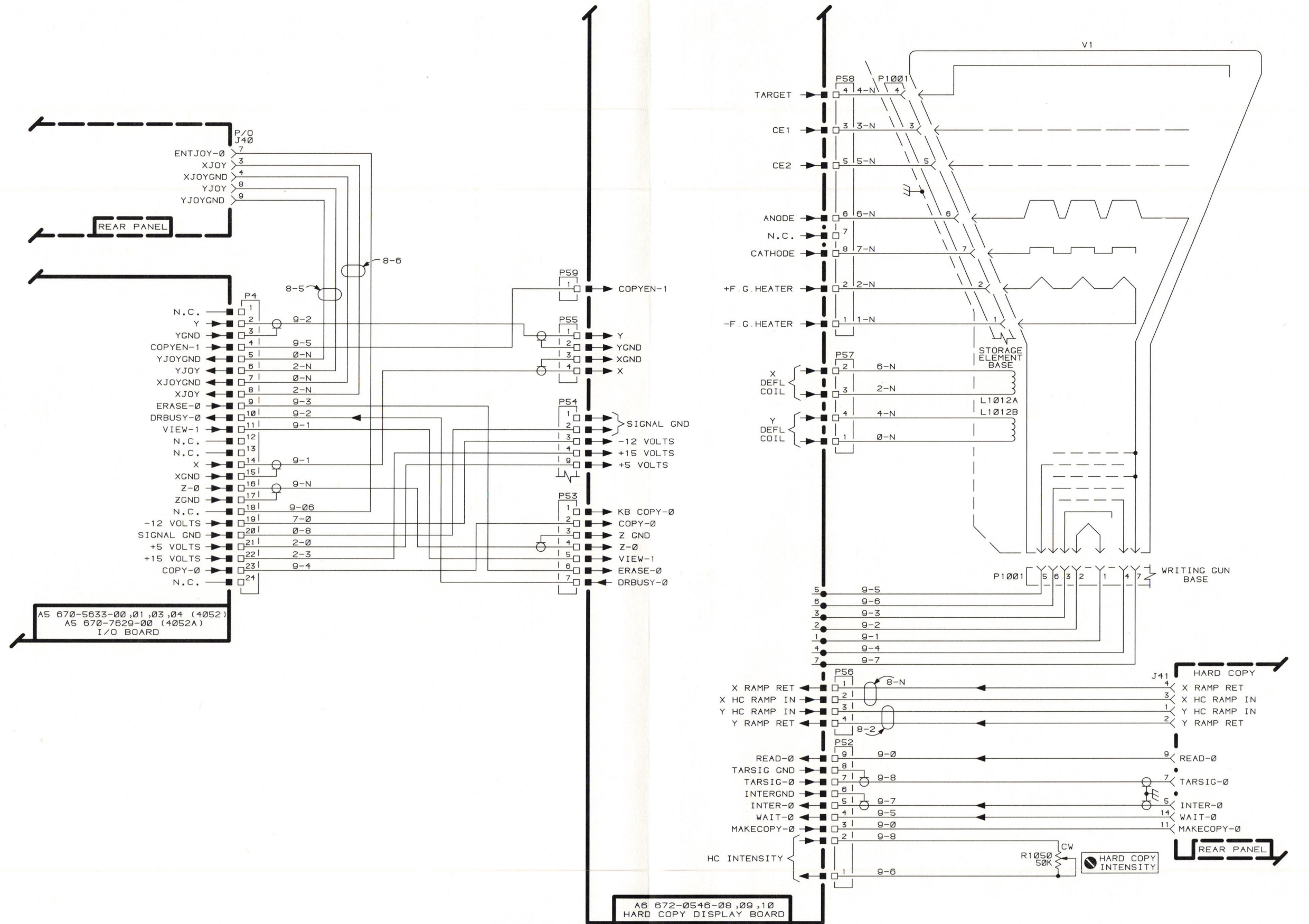

INSTRUMENT:
4052/4052A

NOTES:

2829-12

DIAGRAM:
SYSTEM INTERCONNECT
DISPLAY

SHEET:
2 OF 7

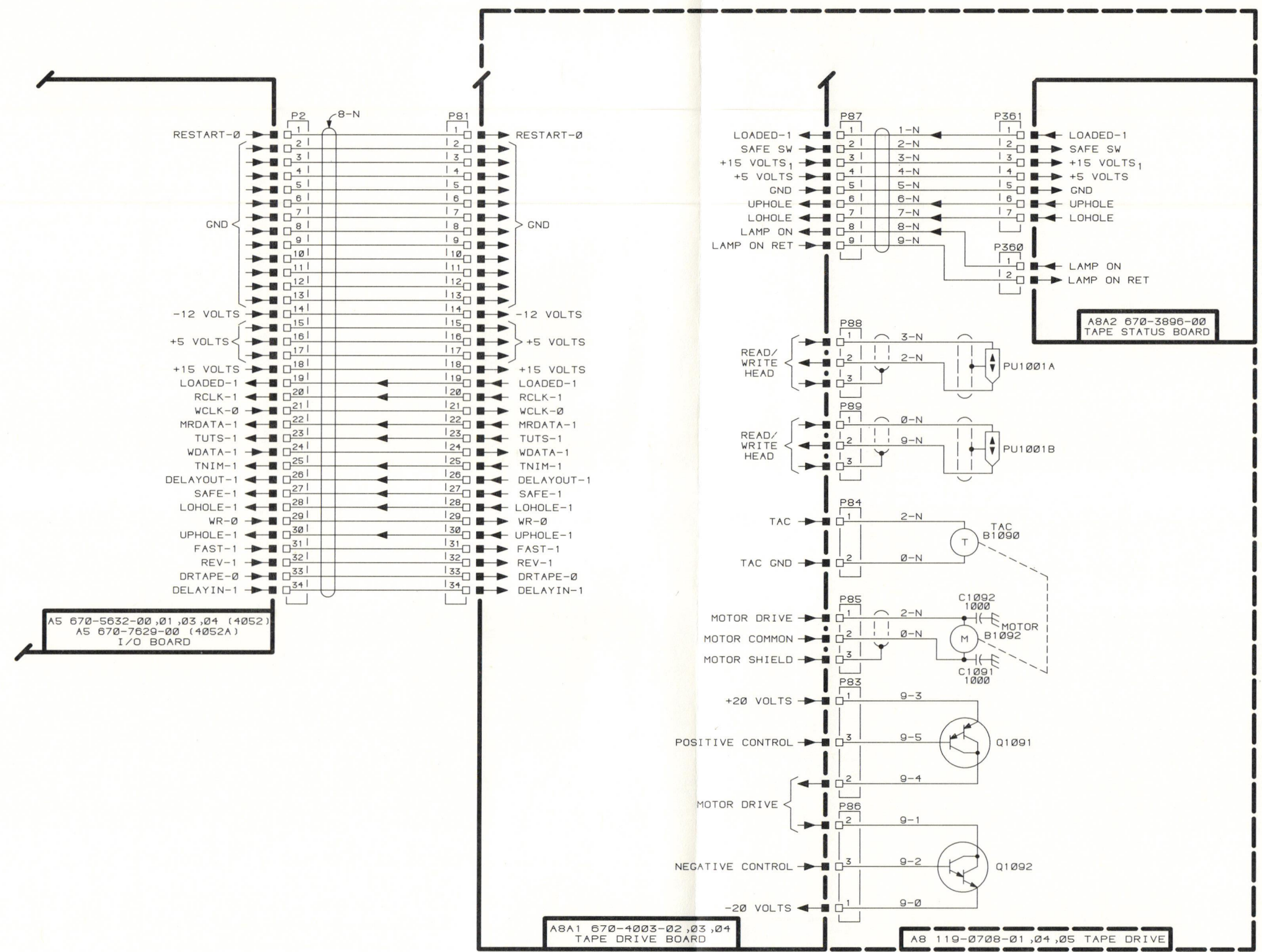

INSTRUMENT: 4052/4052A	NOTES: 2829-13	DIAGRAM: SYSTEM INTERCONNECT TAPE DRIVE	SHEET: 3 OF 7
---------------------------	-----------------------	---	------------------

TAPE DRIVE INTERCONNECT

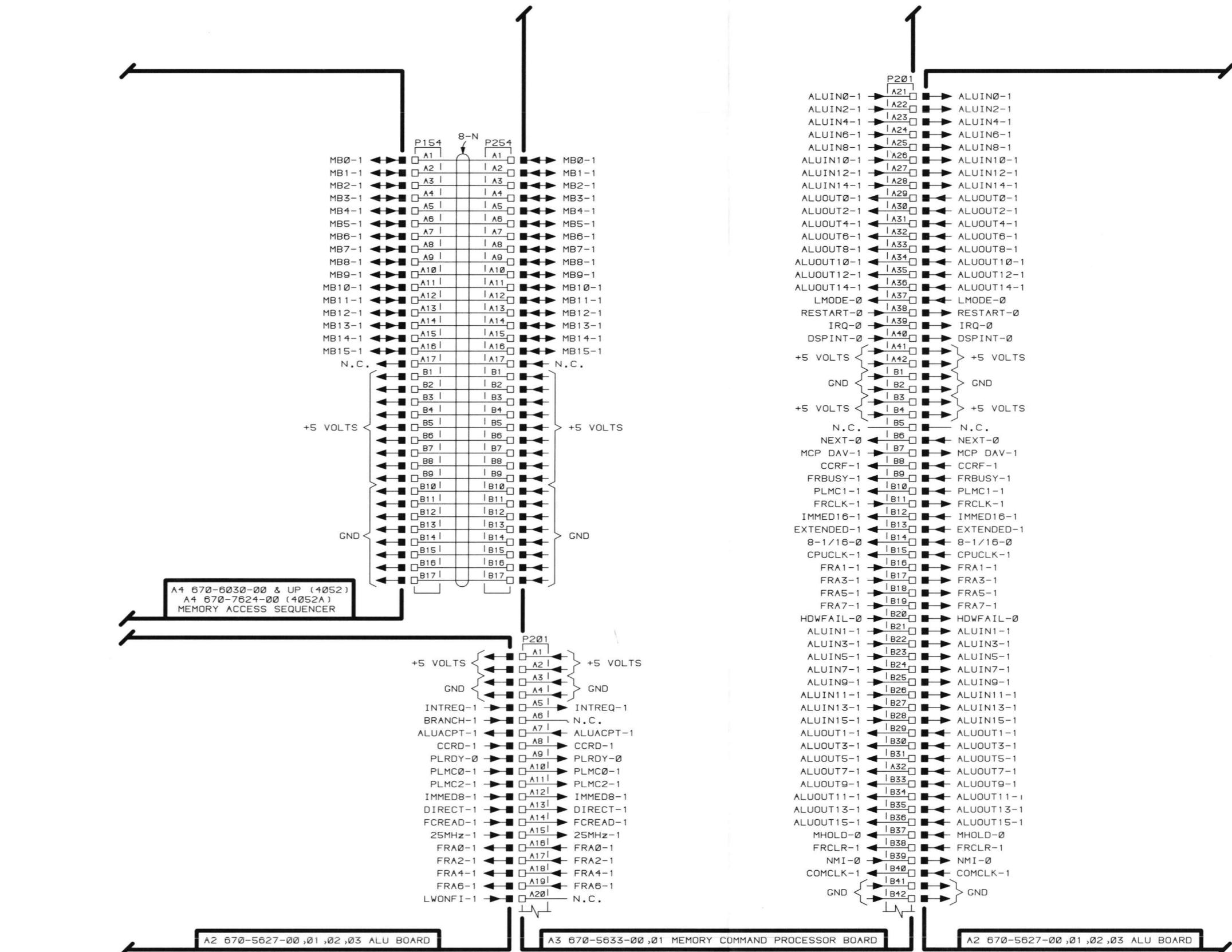

INSTRUMENT: 4052/4052A	NOTES: 2829-14	DIAGRAM: SYSTEM INTERCONNECT MEMORY COMMAND PROCESSOR	SHEET: 4 OF 7
---------------------------	-------------------	---	------------------

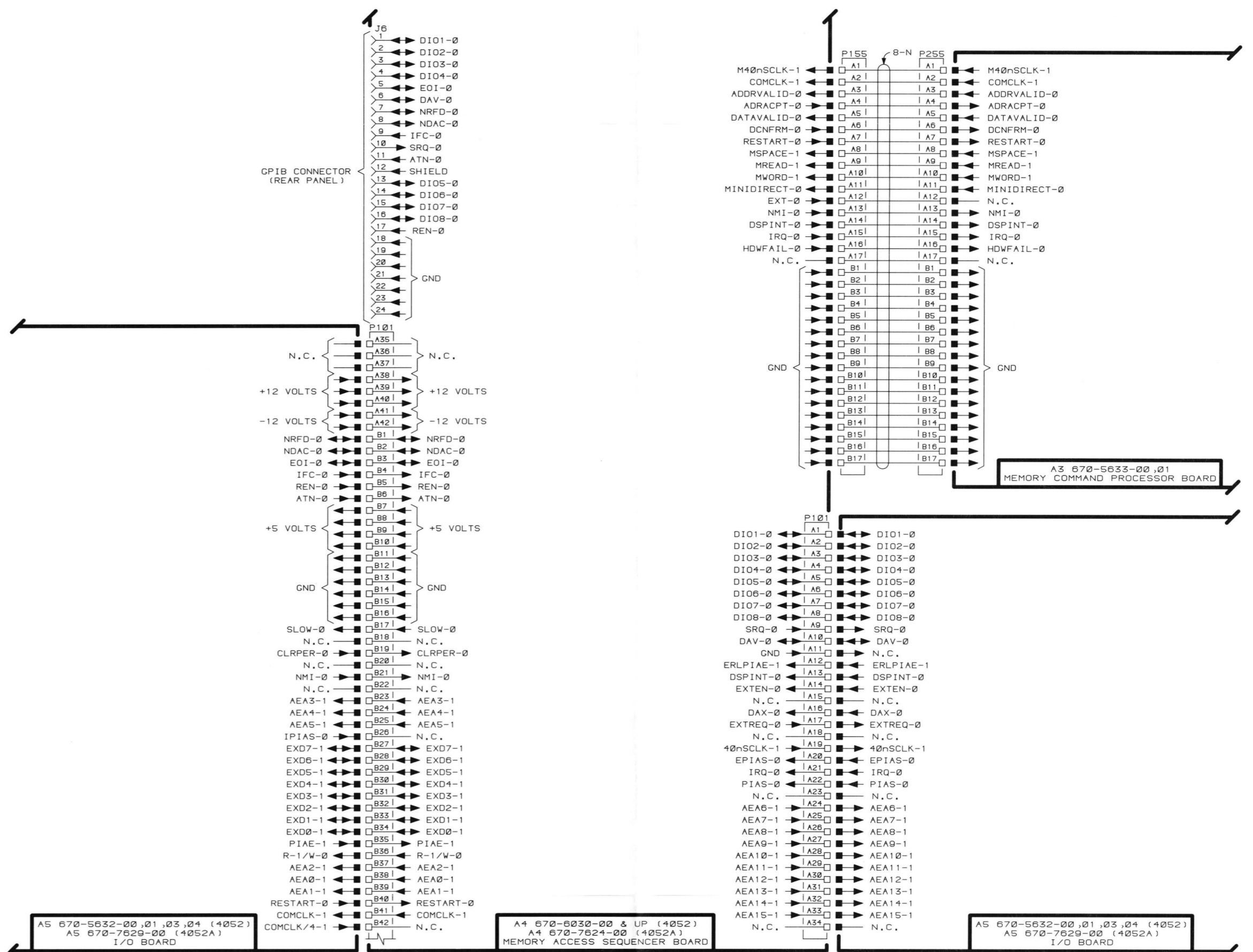

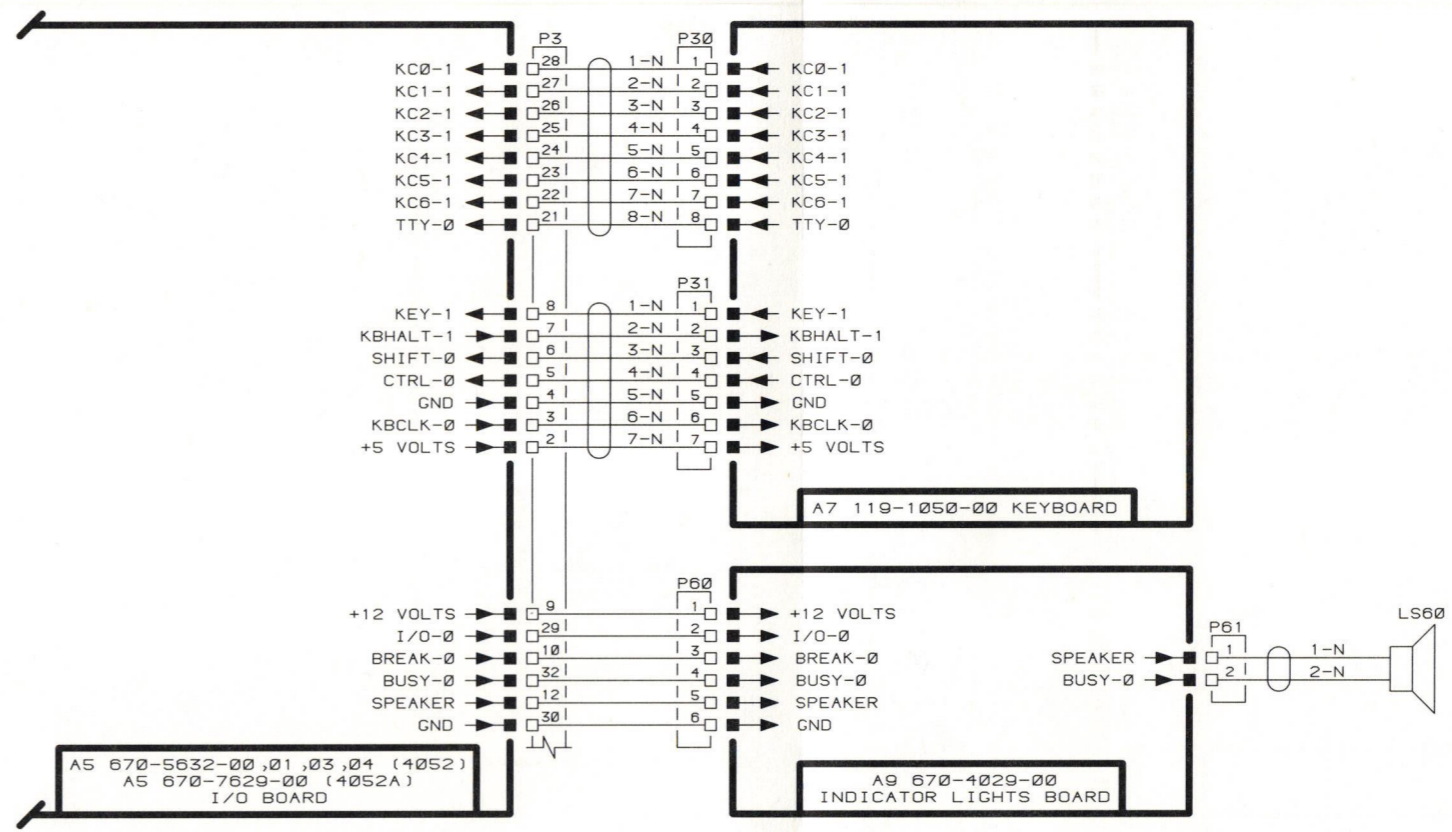

INSTRUMENT: 4052/4052A	NOTES: 2829-16	DIAGRAM: SYSTEM INTERCONNECT KEYBOARD & INDICATOR LIGHTS	SHEET: 6 OF 7
---------------------------	---------------------------	--	------------------

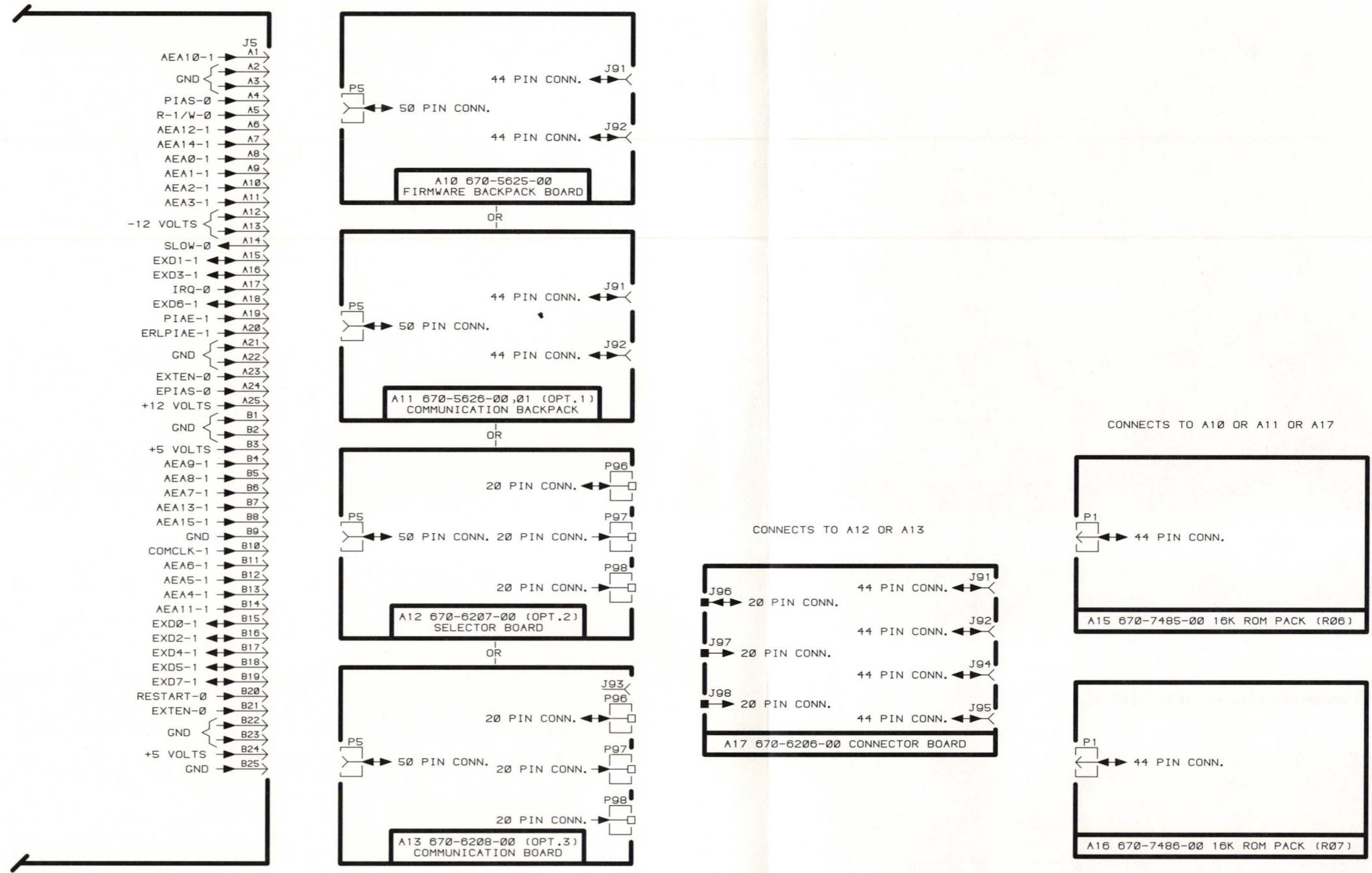

INSTRUMENT: 4052/4052A	NOTES:	2829-17	DIAGRAM: SYSTEM INTERCONNECT BACKPACK OPTIONS	SHEET: 7 OF 7
---------------------------	--------	---------	---	------------------

BACKPACK OPTIONS
INTERCONNECT

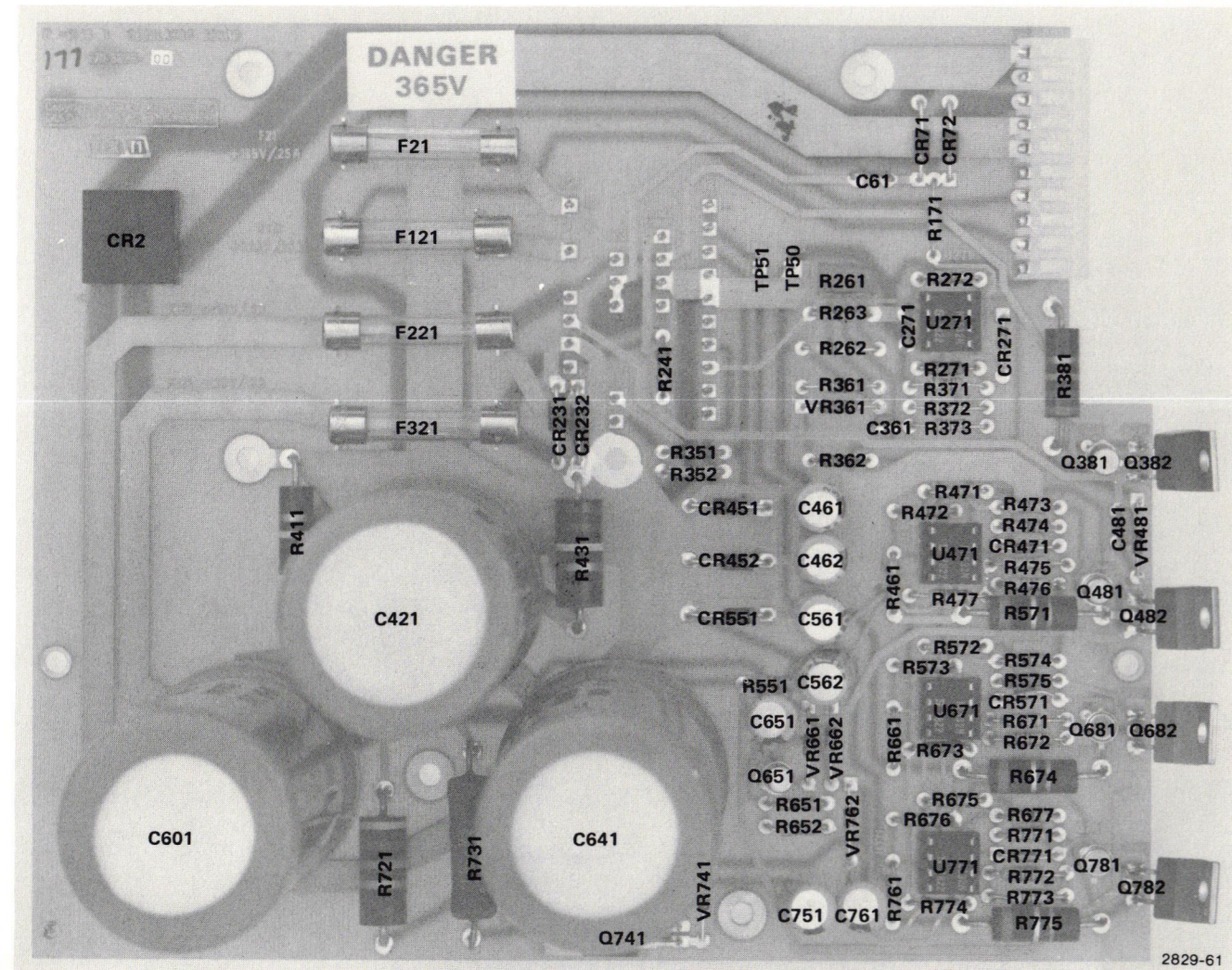

Regulator Board Component Locations (670-5623-00,01).

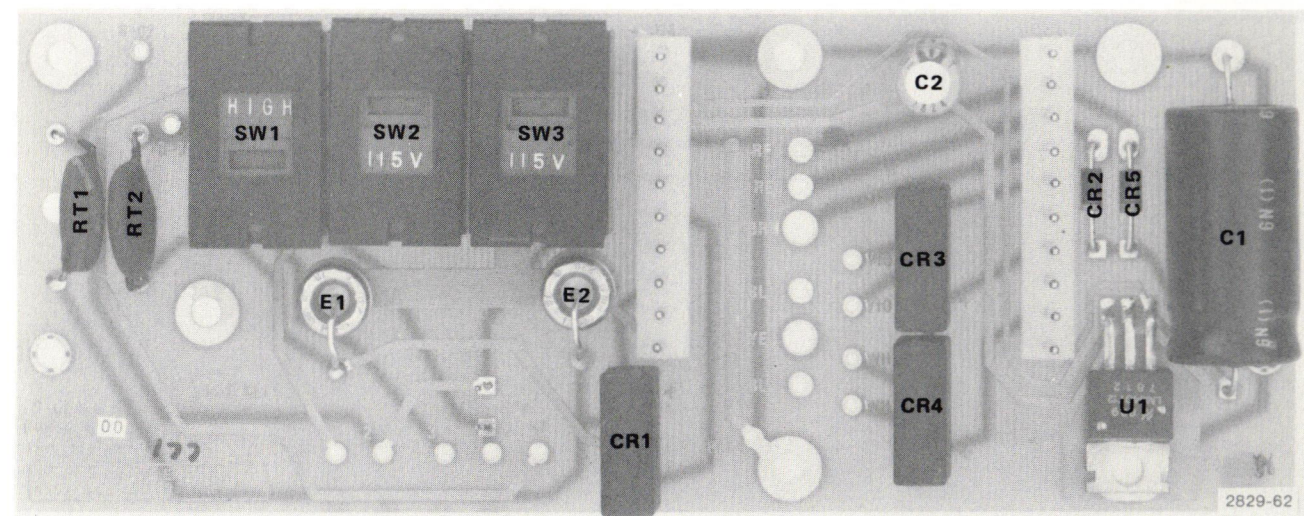

Line Selector Board Component Locations (670-5621-00).

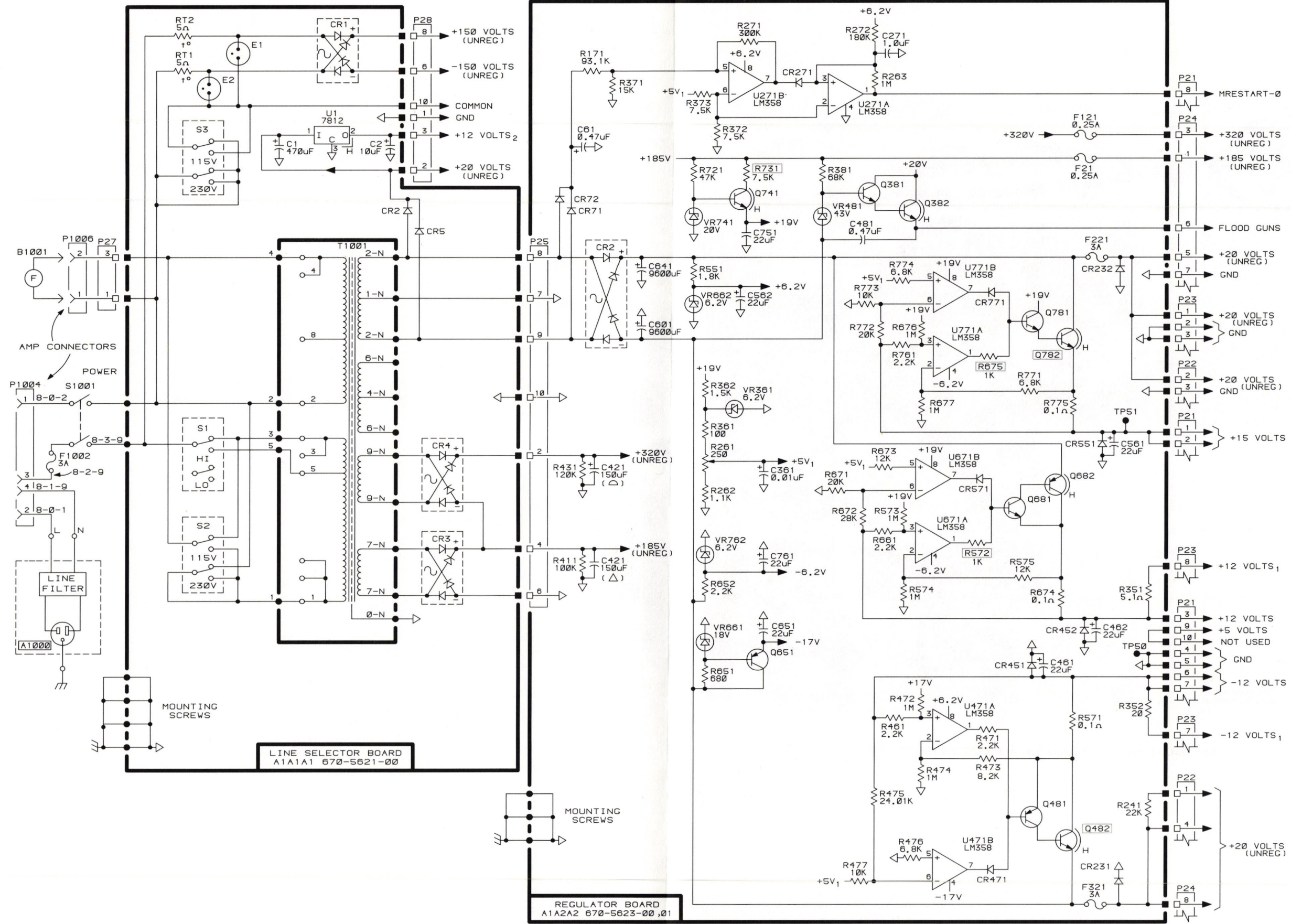

INSTRUMENT:
620-0278-00
(FOR USE WITH 4052/4052A)

NOTES: SEE PARTS LIST FOR EARLIER VALUES AND SERIAL NUMBER RANGES OF PARTS OUTLINED OR DEPICTED IN GREY.

REV, JULY 1982
2829-S1

BOARD: 672-0831-00, 670-5621-00, 672-0833-00, 670-5623-00, 01
LINE SELECTOR BOARD
REGULATOR BOARD

ASSEMBLY-SHEET:
A1-1
(1 OF 2)

LINE SELECTOR & REGULATOR A1-1
670-5621-00, 670-5623-00, 01

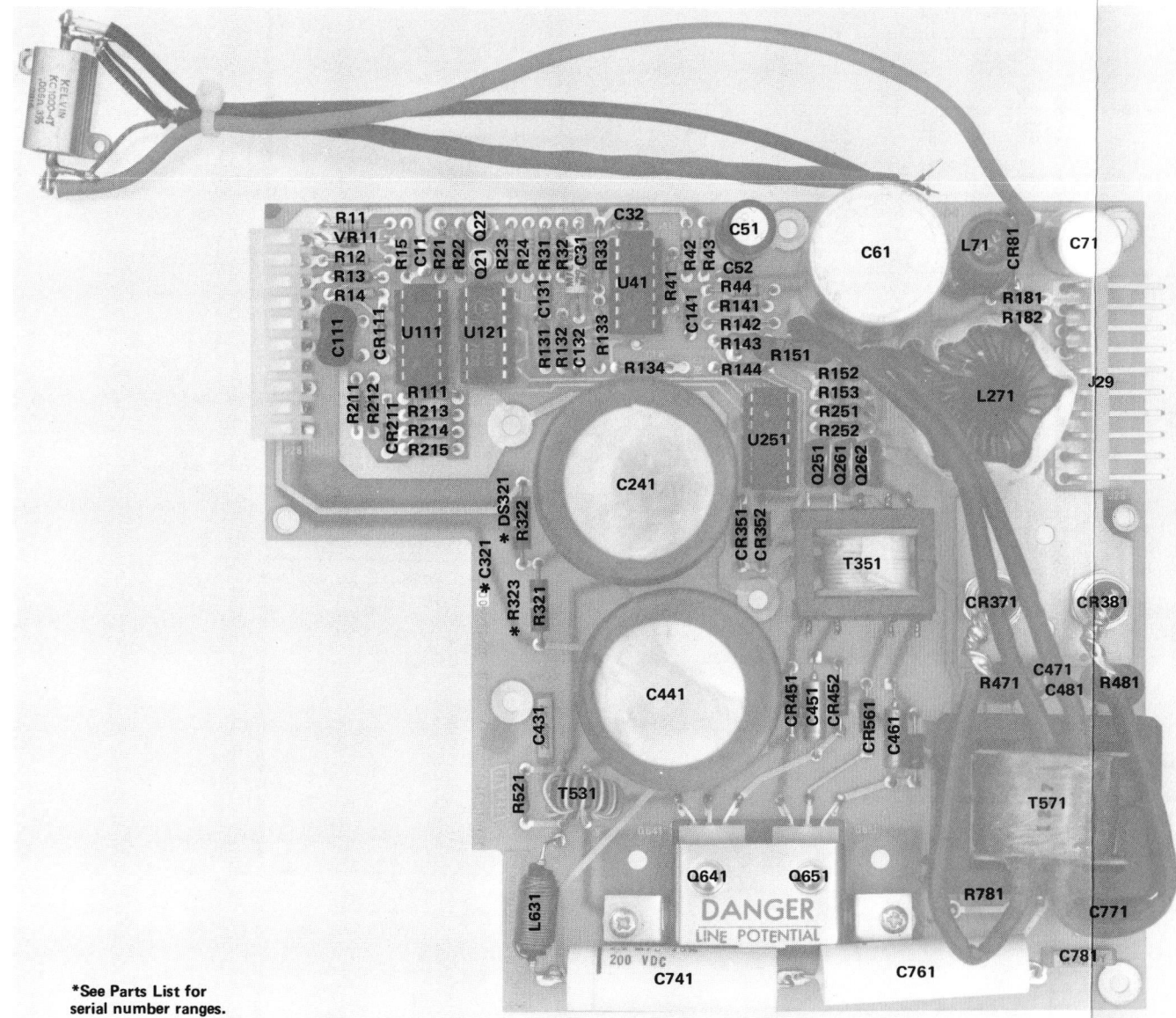

*See Parts List for serial number ranges.

2829-63A

+5 Volt Output Board Component Locations (670-5622-00,01,02).

+5 VOLT OUTPUT COMPONENT LOCATIONS

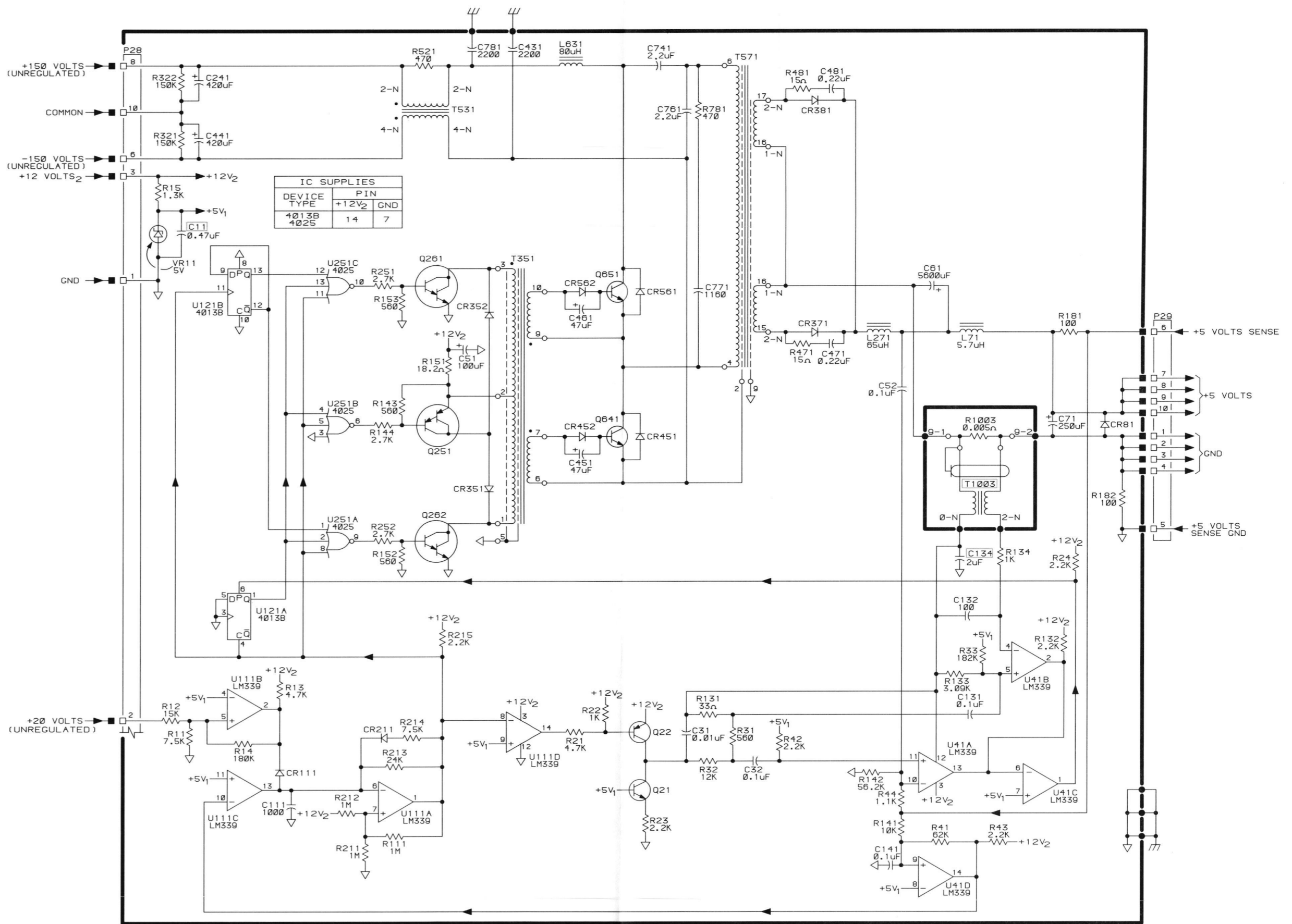

IC SUPPLIES		
DEVICE TYPE	PIN	
4013B	14	
4025	7	

<p>INSTRUMENT: 620-0278-00 (FOR USE WITH 4052/4052A)</p>	<p>NOTES: SEE PARTS LIST FOR EARLIER VALUES AND SERIAL NUMBER RANGES OF PARTS OUTLINED OR DEPICTED IN GREY.</p>	<p>REV, JULY 1982 2829-S2</p>	<p>BOARD: 670-5622-00, 01 / 672-0833-00, 01 +5 VOLT OUTPUT BOARD</p>	<p>ASSEMBLY-SHEET: A1-2 (2 OF 2)</p>
--	---	-----------------------------------	---	--

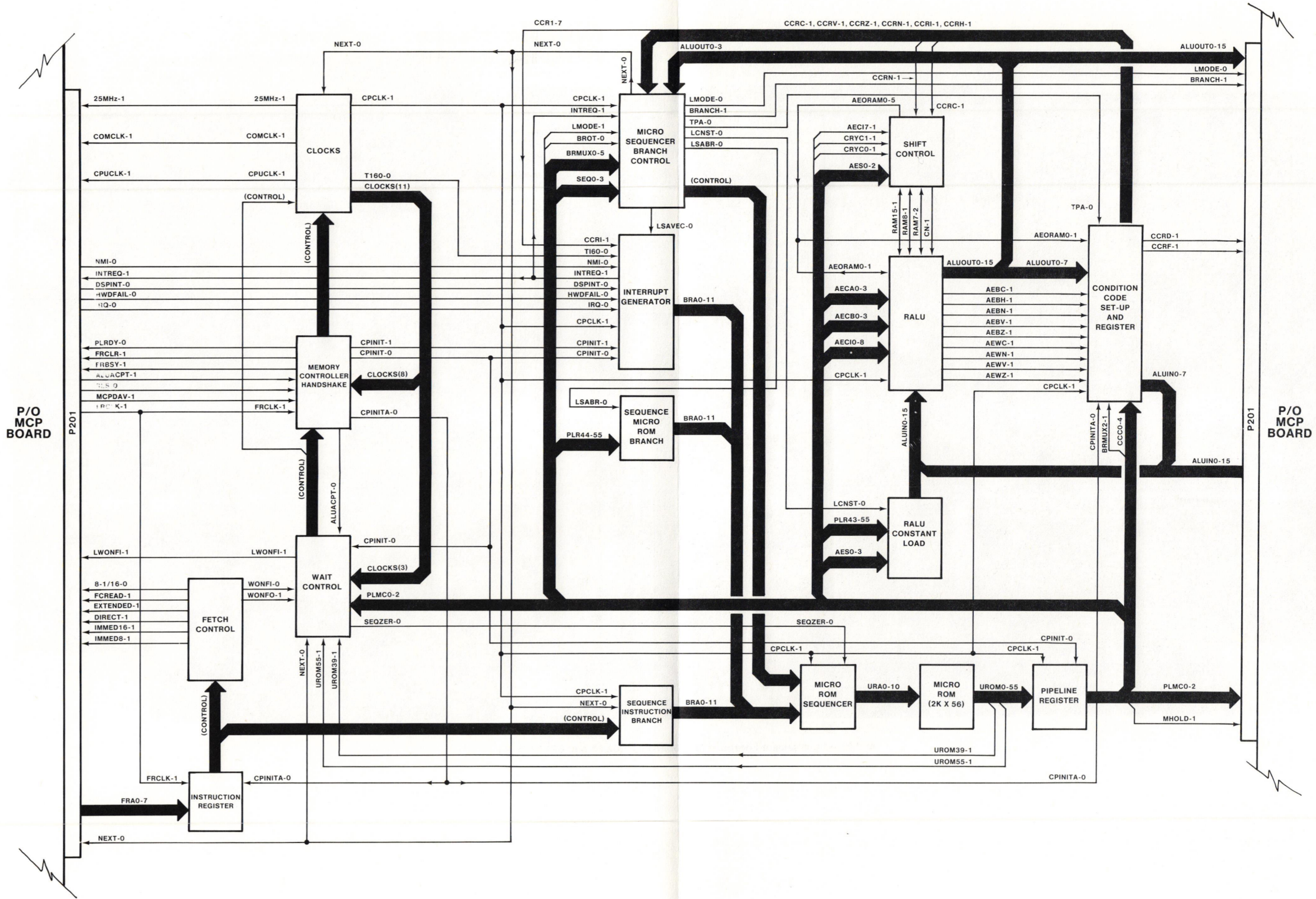

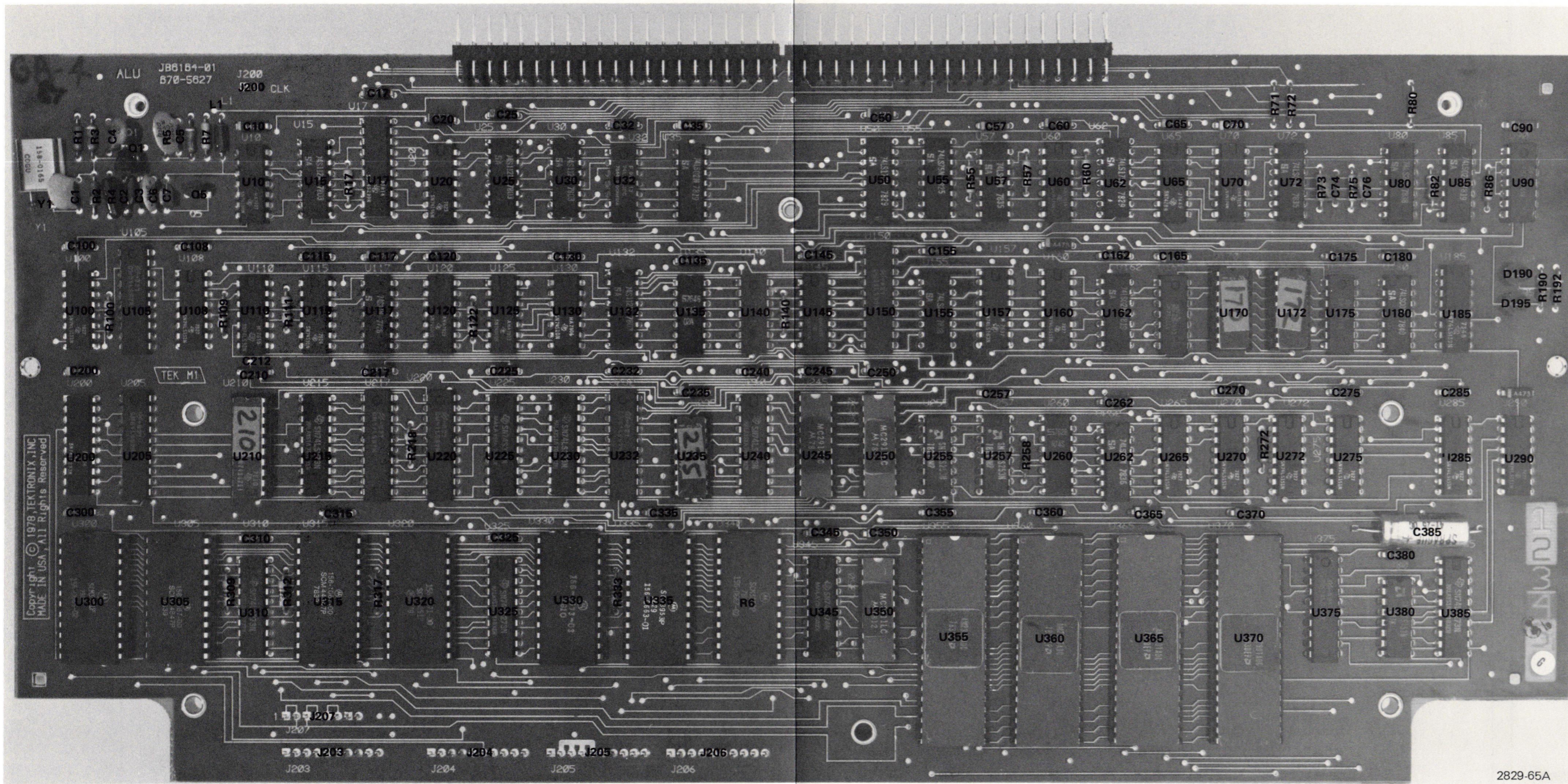

ALU Board Component Locations (670-5627-00,01,02,03 and 670-7705-00).

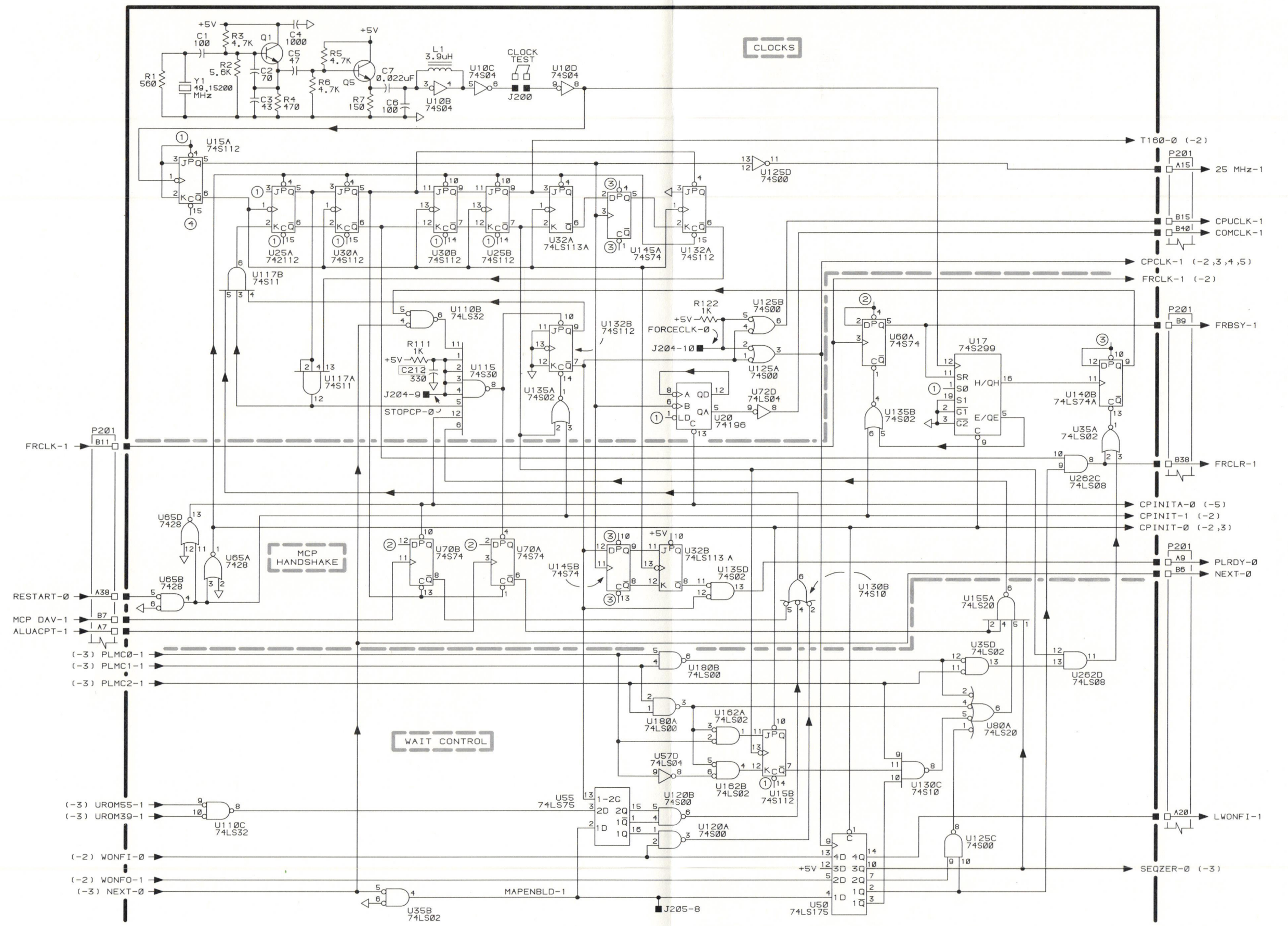

INSTRUMENT: 4052/4052A	NOTES: SEE PARTS LIST FOR EARLIER VALUES AND SERIAL NUMBER RANGES OF PARTS OUTLINED OR DEPICTED IN GREY.	REV, JULY 1982 2829-S3	BOARD: 670-5627-00,01,02,03 ALU BOARD	ASSEMBLY-SHEET: A2-1 (1 OF 5)
----------------------------------	--	---------------------------	---	--

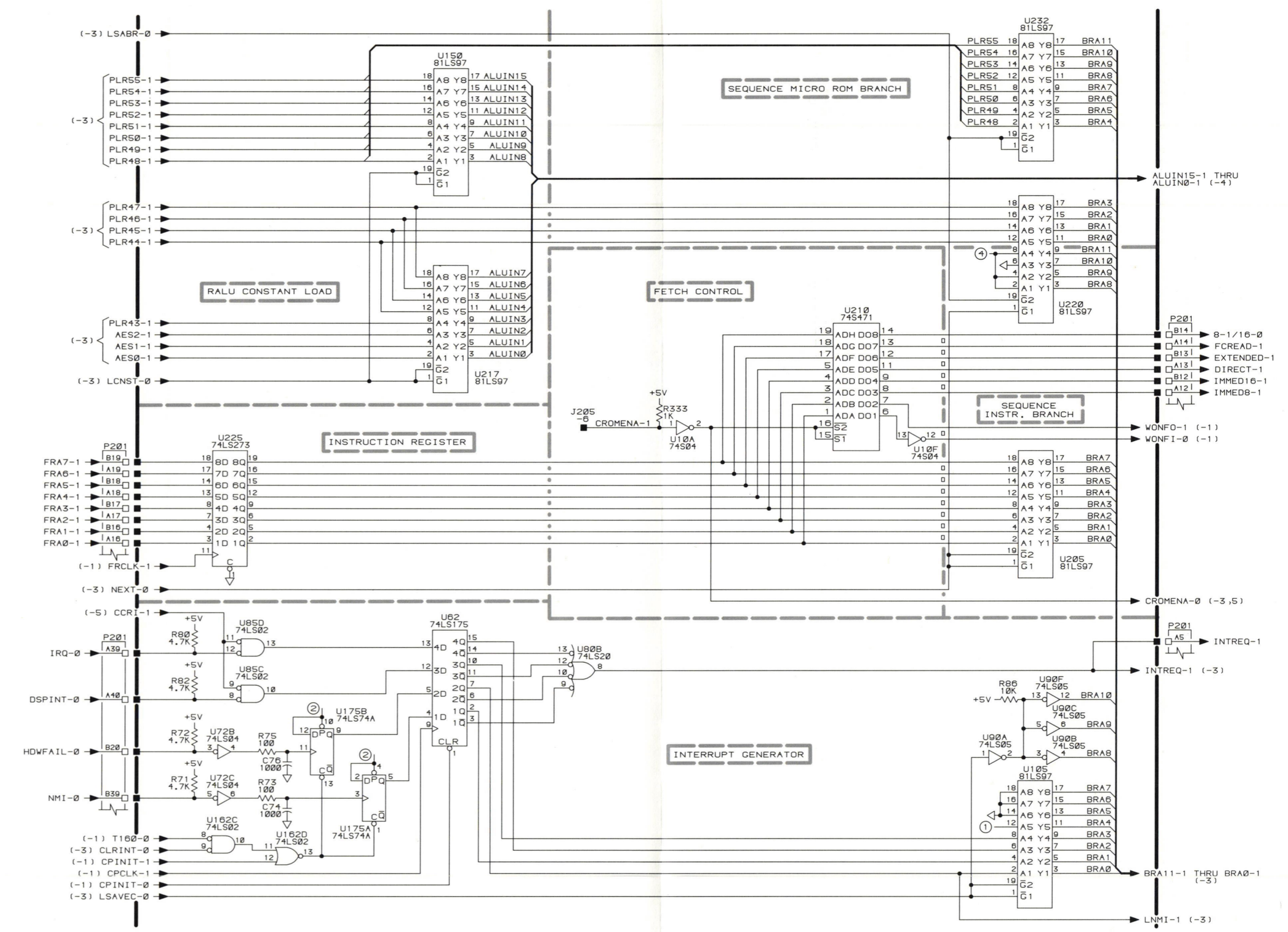

INSTRUMENT: 4052/4052A	NOTES: REV, JULY 1982 2829-S4	BOARD: 670-5627-00,01,02,03 ALU BOARD	ASSEMBLY-SHEET: A2-2 (2 OF 5)
---------------------------	-------------------------------------	--	-------------------------------------

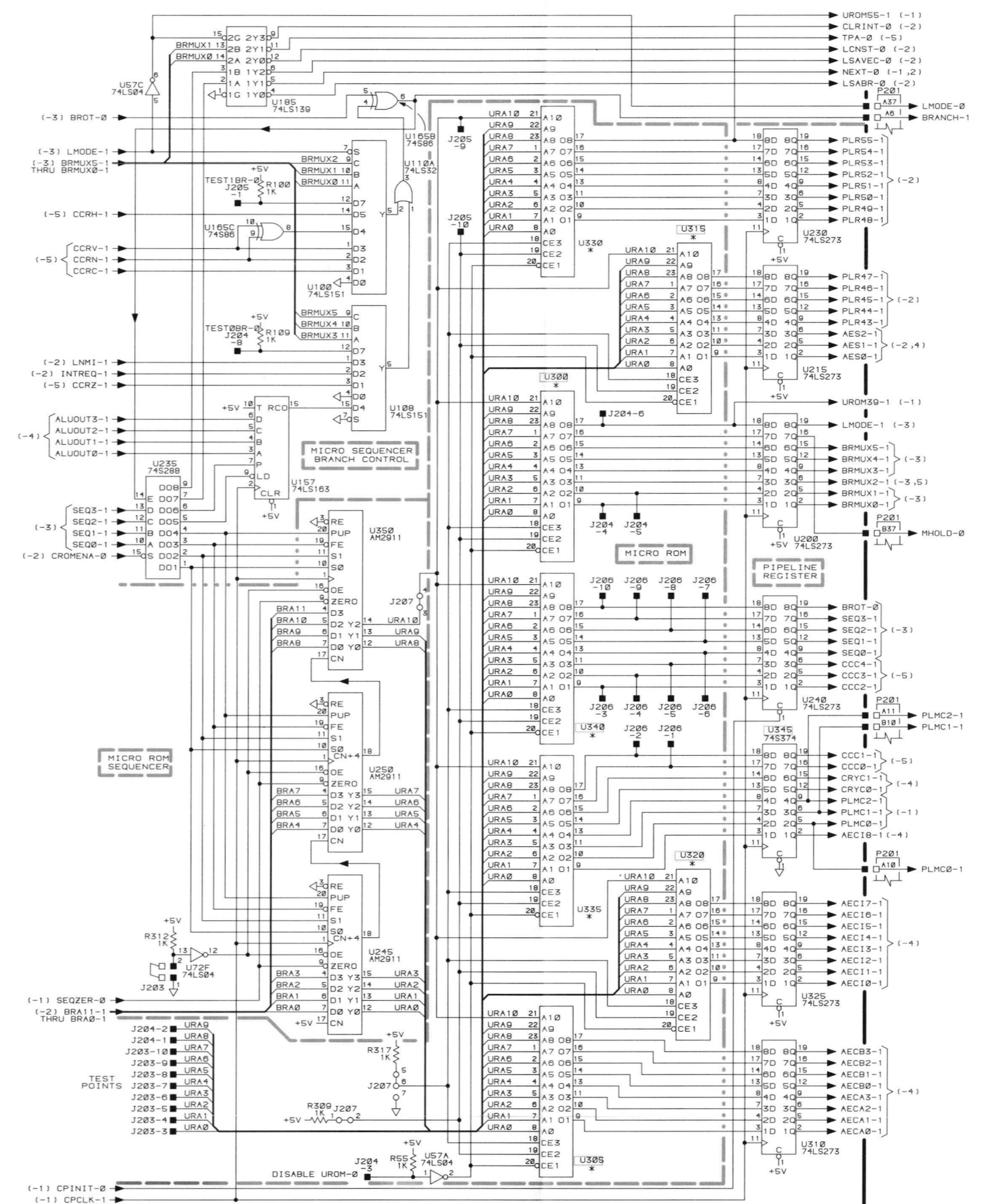

INSTRUMENT: 4052/4052A	NOTES: SEE PARTS LIST FOR EARLIER VALUES AND SERIAL NUMBER RANGES. ON PARTS LIST, LINE OR DELETED IN GREY. REV. JULY 1982 * MAY BE EITHER 8252708 OR 825181	BOARD: 670-5627-00,01,02,03	ALU BOARD	ASSEMBLY-SHEET: A2-3 (3 OF 5)
---------------------------	---	--------------------------------	-----------	-------------------------------------

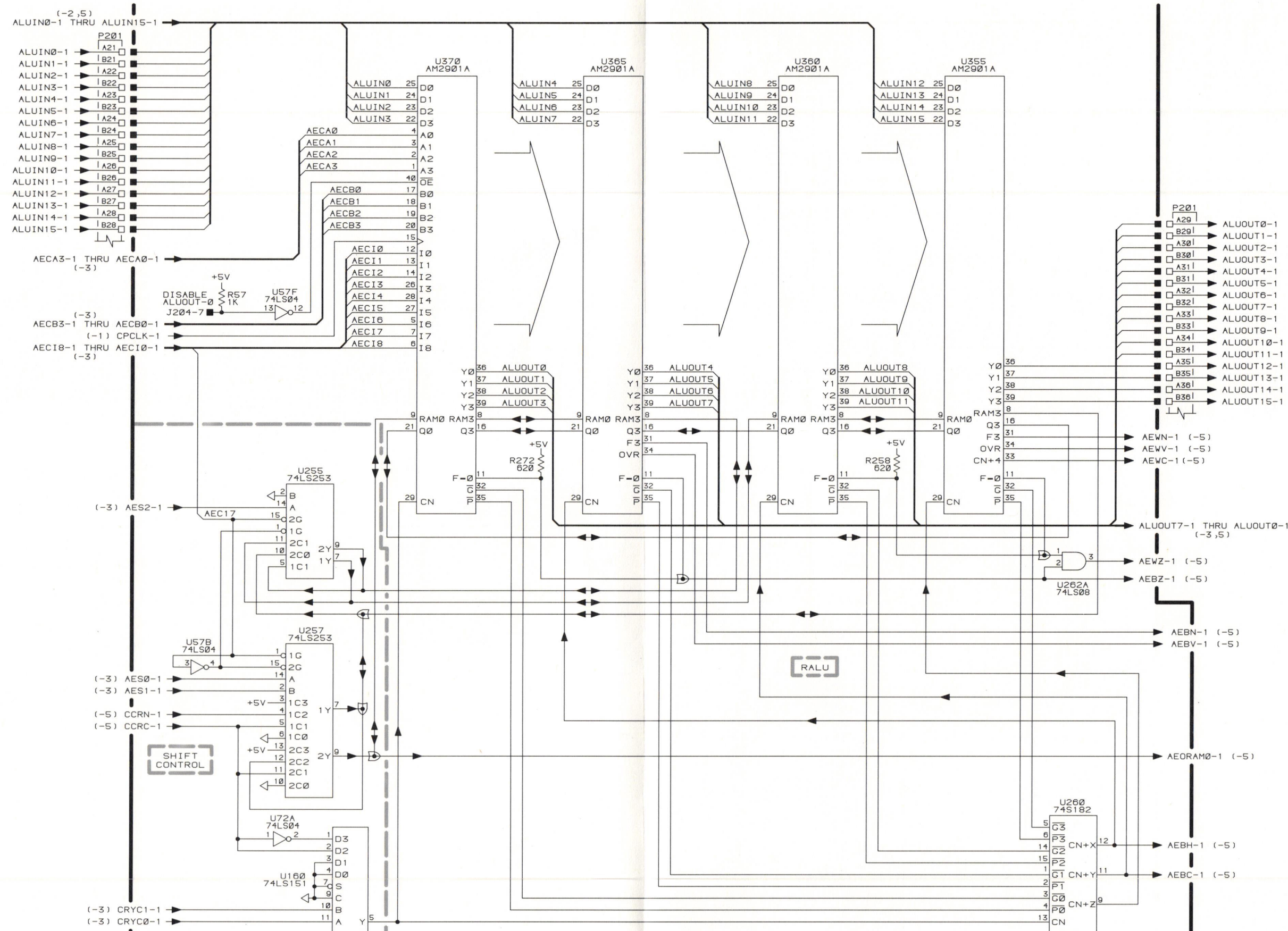

INSTRUMENT: 4052/4052A	NOTES: REV, JULY 1982 2829-56	BOARD: 670-5627-00,01,02,03 ALU BOARD	ASSEMBLY-SHEET: A2-4 (4 OF 5)
---------------------------	-------------------------------------	--	-------------------------------------

4052 670-5627-00,01,02,03
4052A 670-7705-00

A2-4

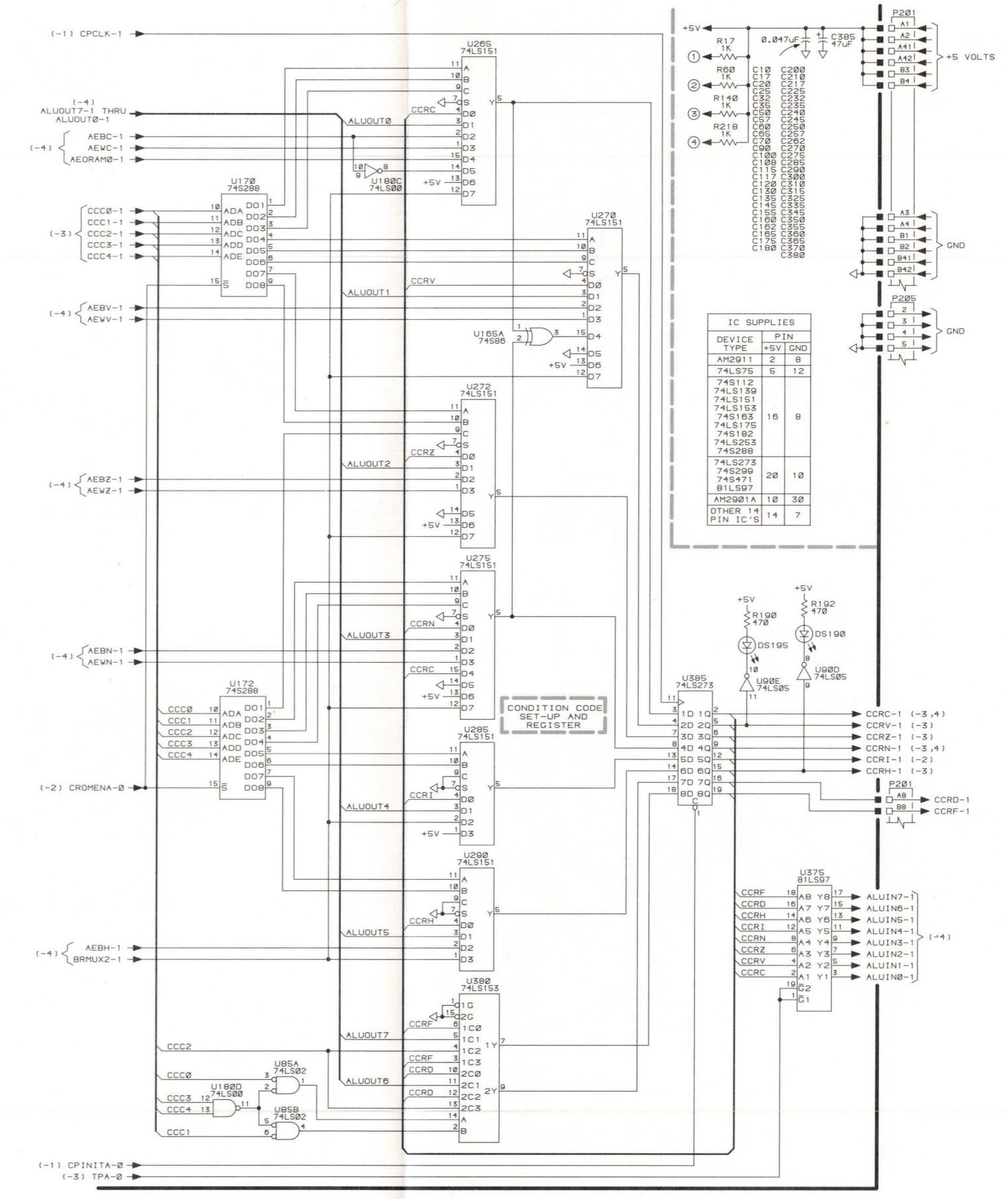

INSTRUMENT:	NOTES:	REV, JULY 1982	BOARD: 670-5627-00,01,02,03	ASSEMBLY-SHEET:
4052/4052A		2829-57	ALU BOARD	A2-5 (5 OF 5)

4052 ALU BOARD
 670-5627-00,01,02,03
 A2-5
 4052A 670-7705-00

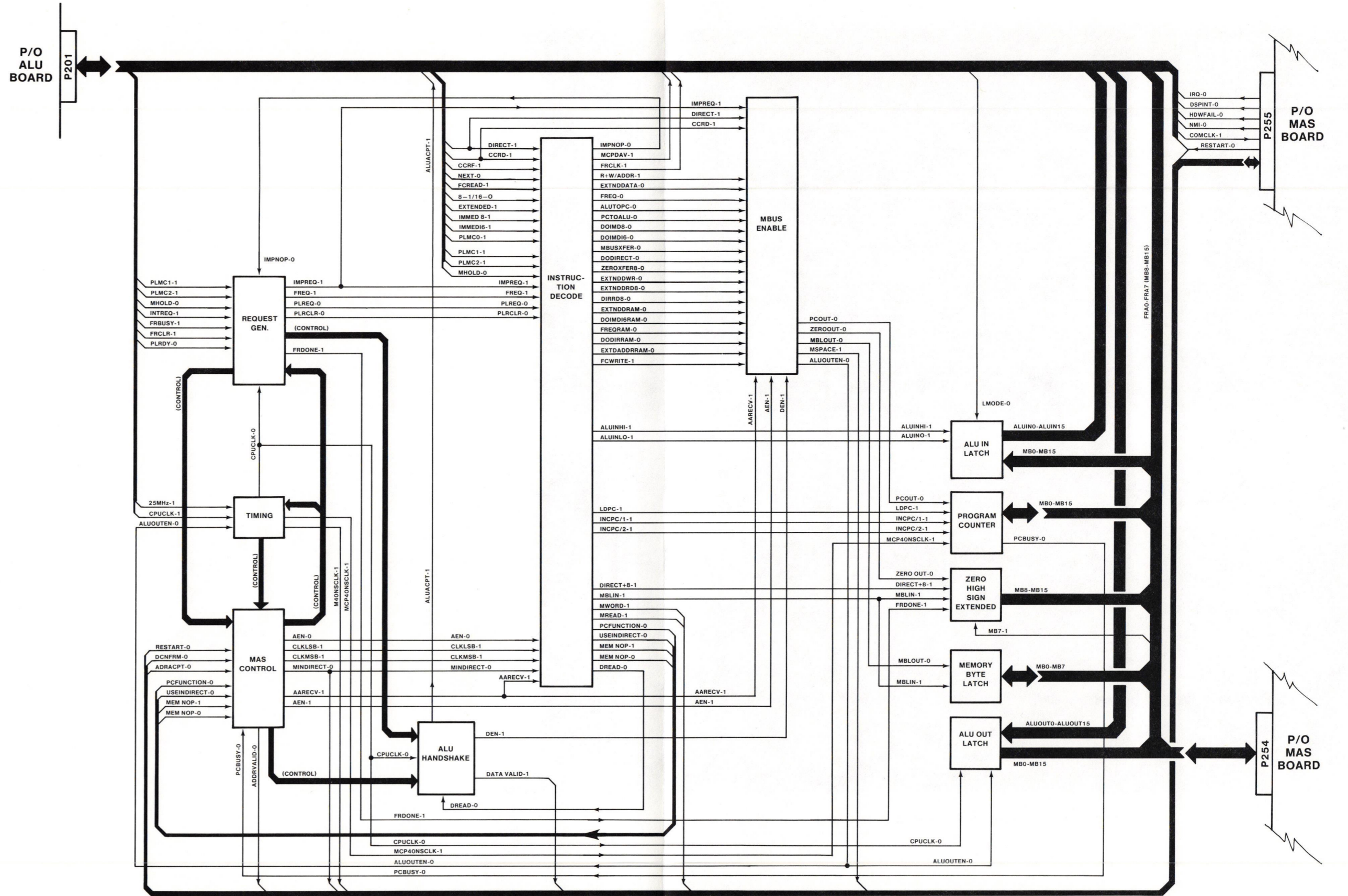

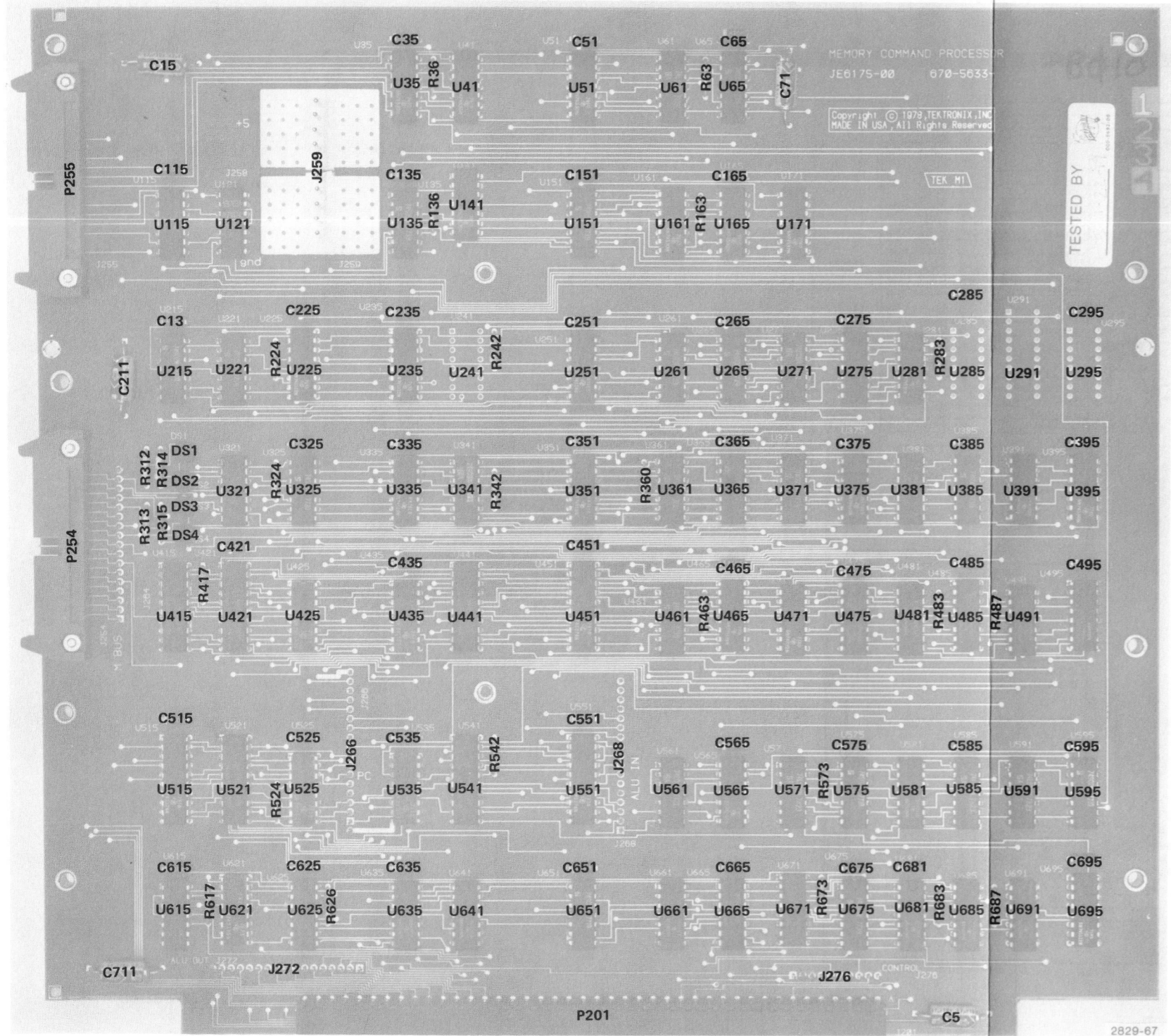

MCP Board Component Locations (670-5633-00,01).

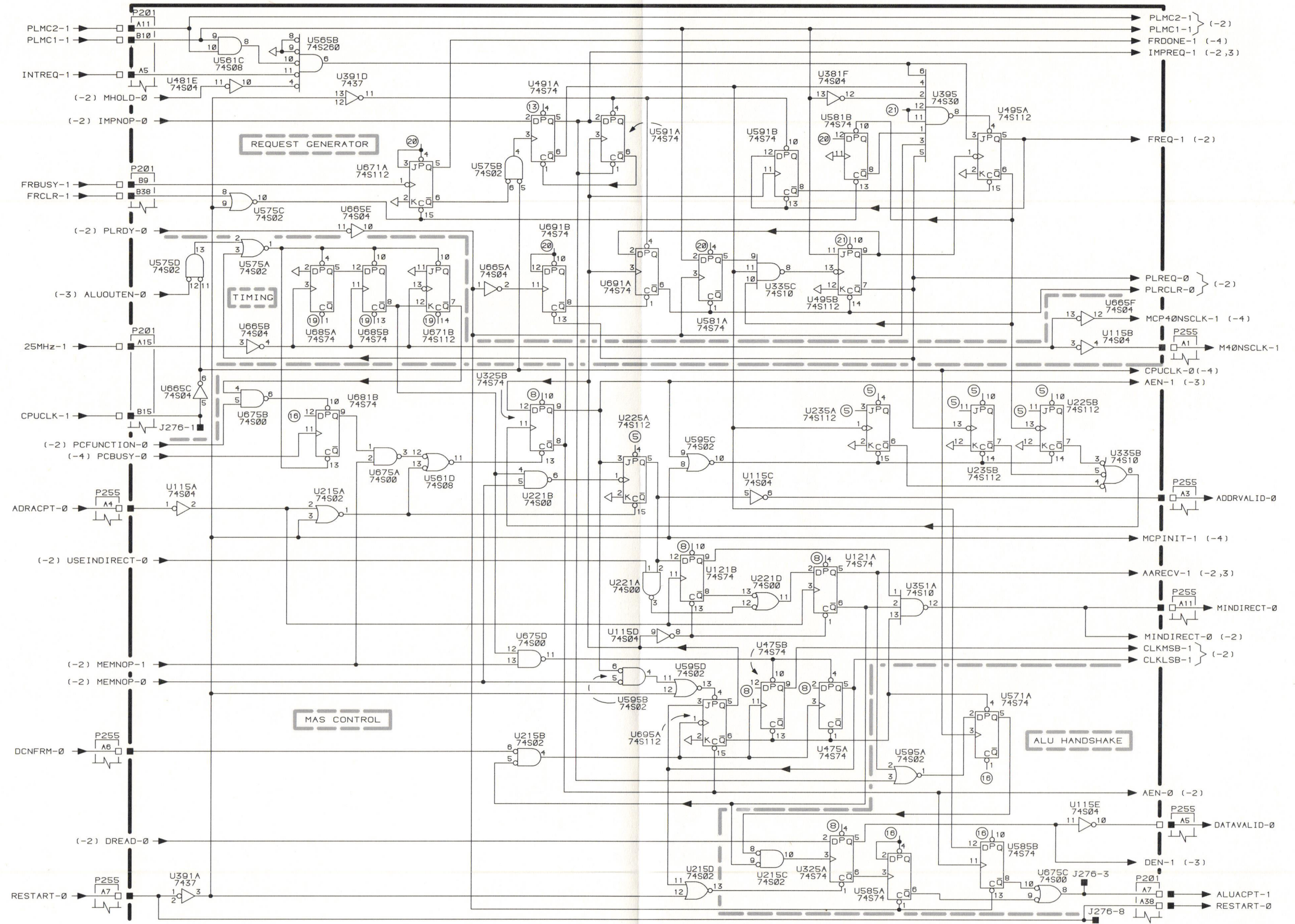

INSTRUMENT:
4052/4052A

NOTES:

REV. JULY 1982
2829-S8

BOARD: 670-5633-00,01

MEMORY COMMAND PROCESSOR

ASSEMBLY-SHEET:
A3-1
(1 OF 4)

MCP BOARD 670-5633-00, 01 A3-1

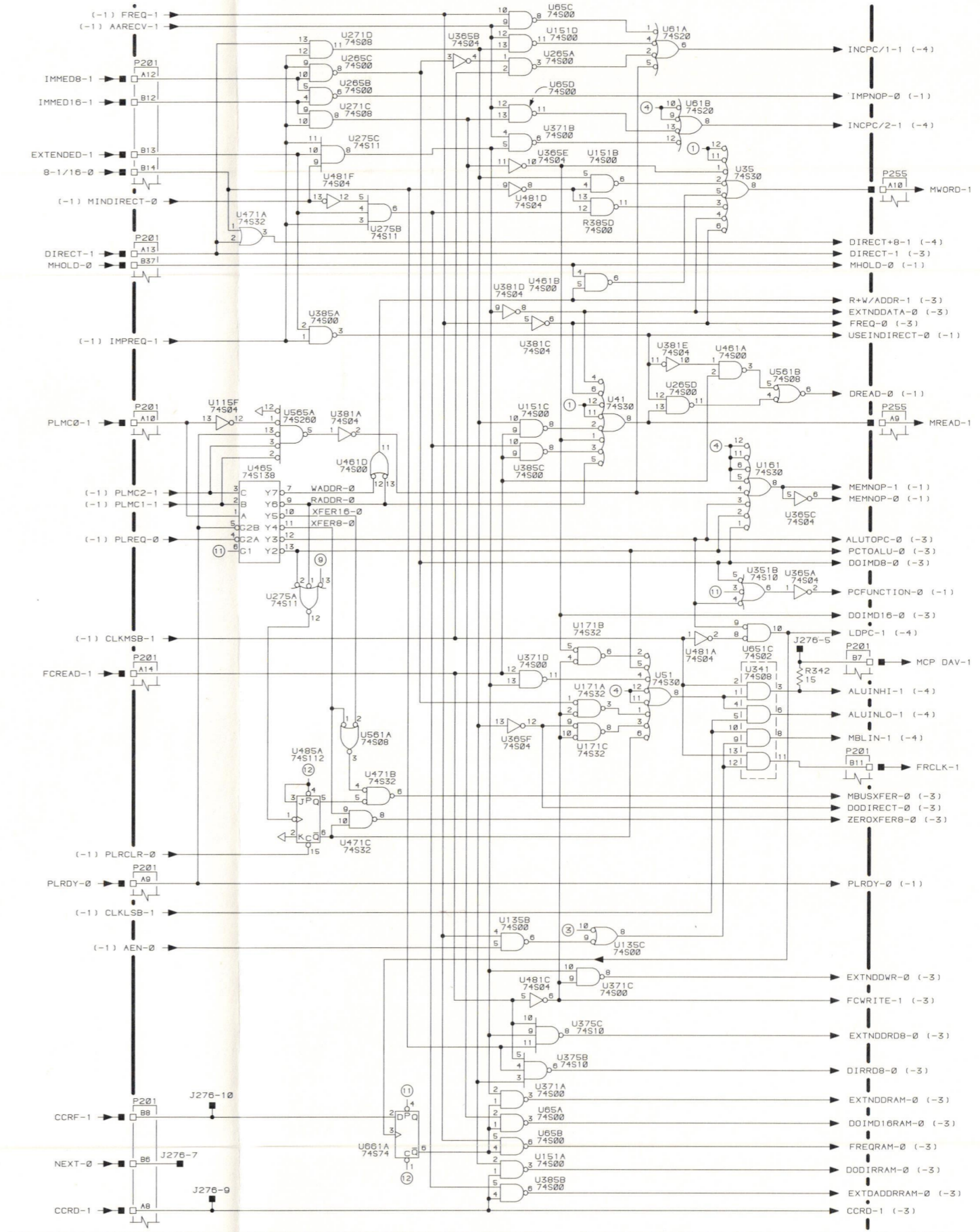

INSTRUMENT: 4052/4052A	NOTES: REV, JULY 1982 2829-S9	BOARD: 670-5633-00,01 MEMORY COMMAND PROCESSOR INSTRUCTION DECODE	ASSEMBLY-SHEET: A3-2 (2 OF 4)
---------------------------	-------------------------------------	---	-------------------------------------

MCP BOARD 670-5633-00,01 A3-2

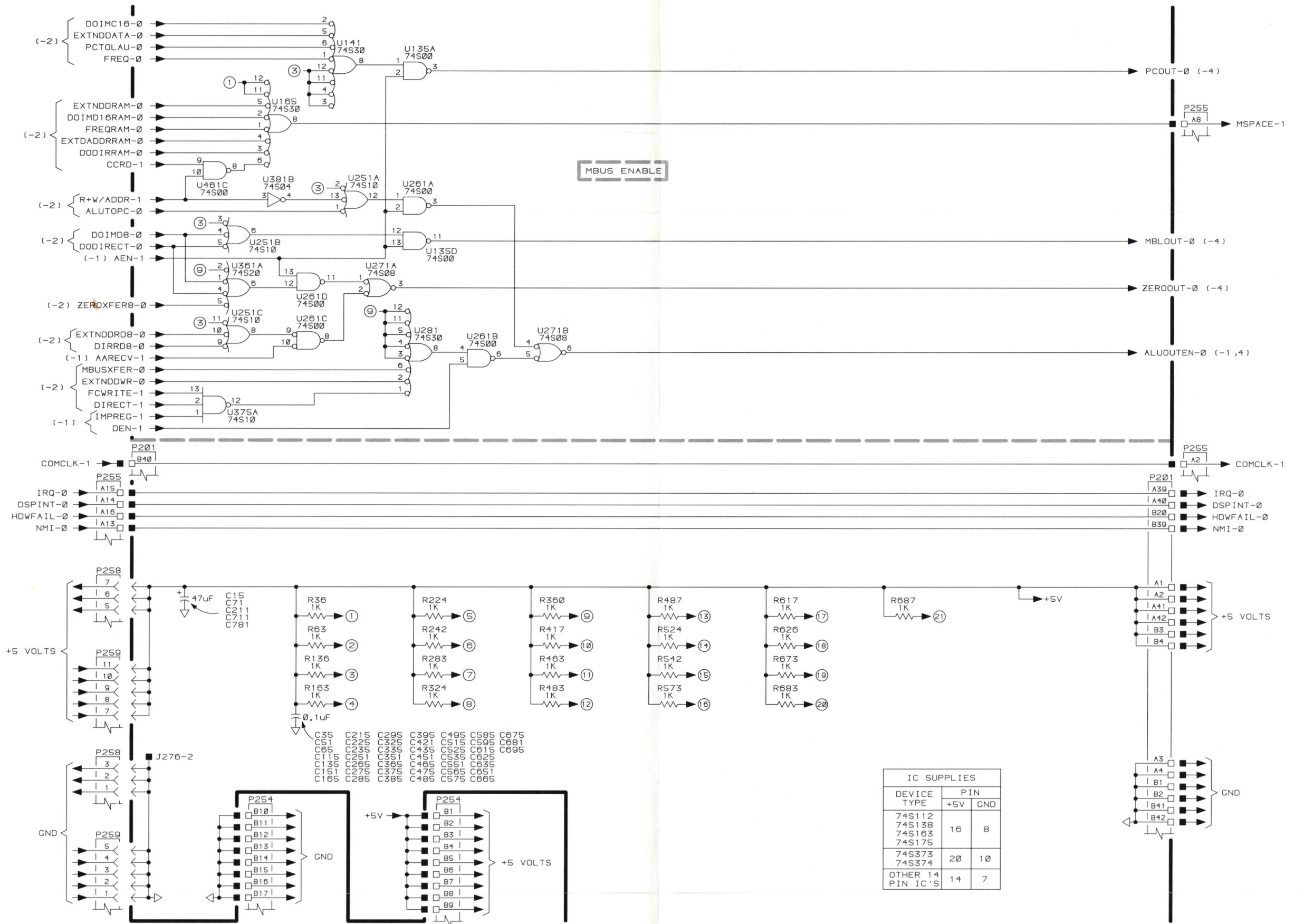

INSTRUMENT: 4052/4052A NOTES: REV, JULY 1982 BOARD: 670-5633-00,01 ASSEMBLY-SHEET: A3-3 (3 OF 4)

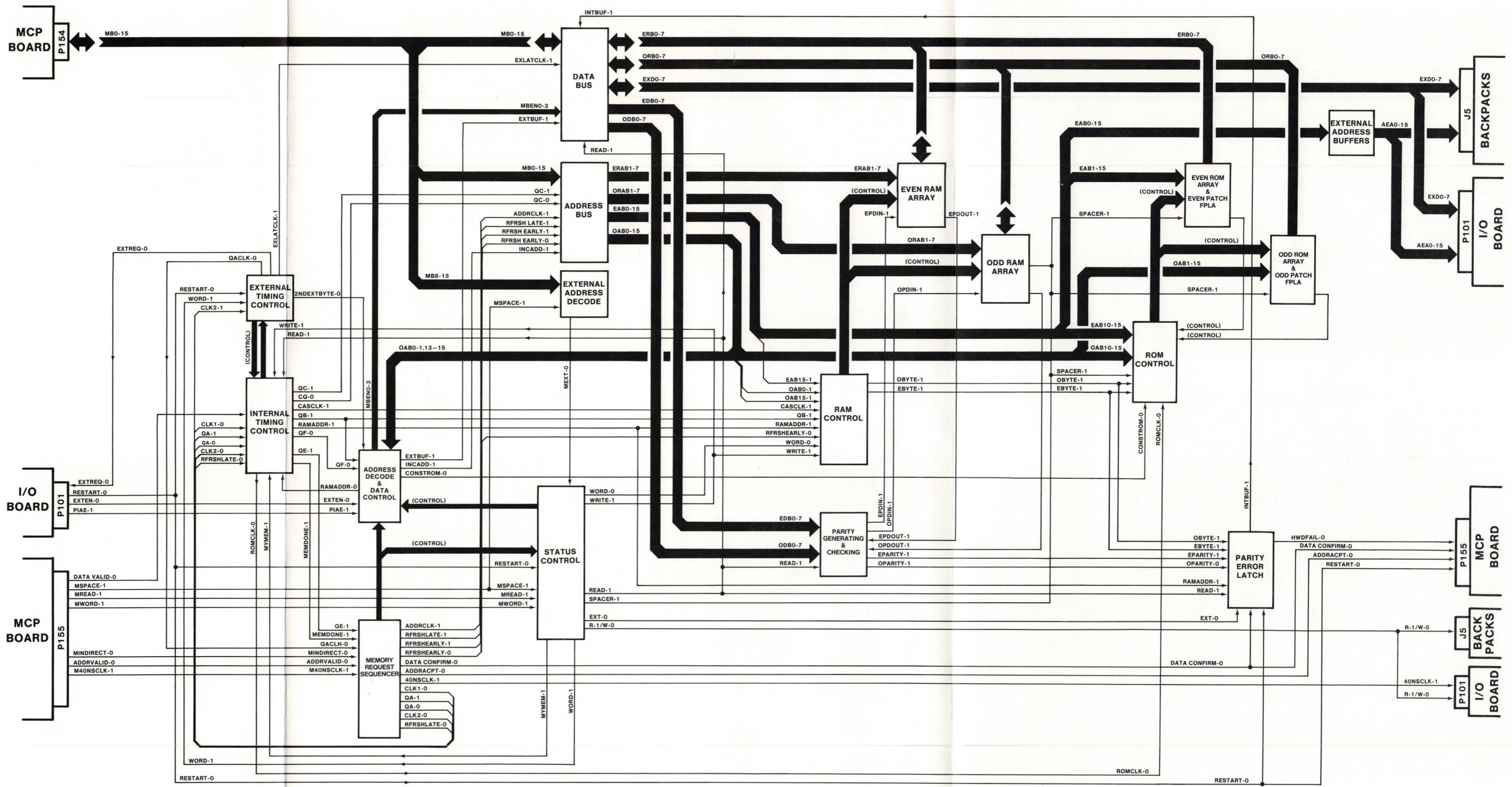

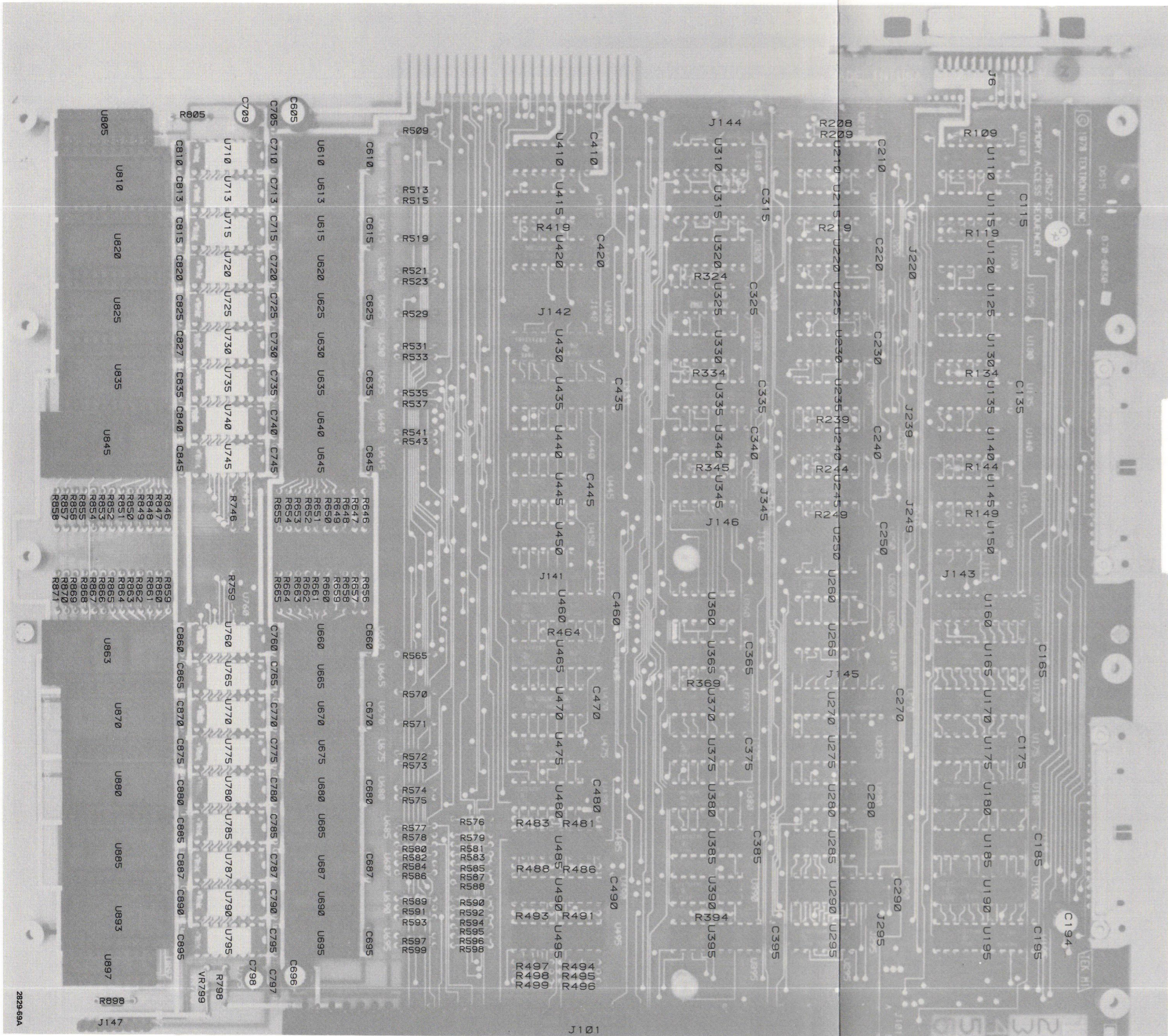

4052 MAS Board Component Locations (670-6030-00 and up).

REV, JUL 1982

4052/4052A PARTS AND SCHEMATICS

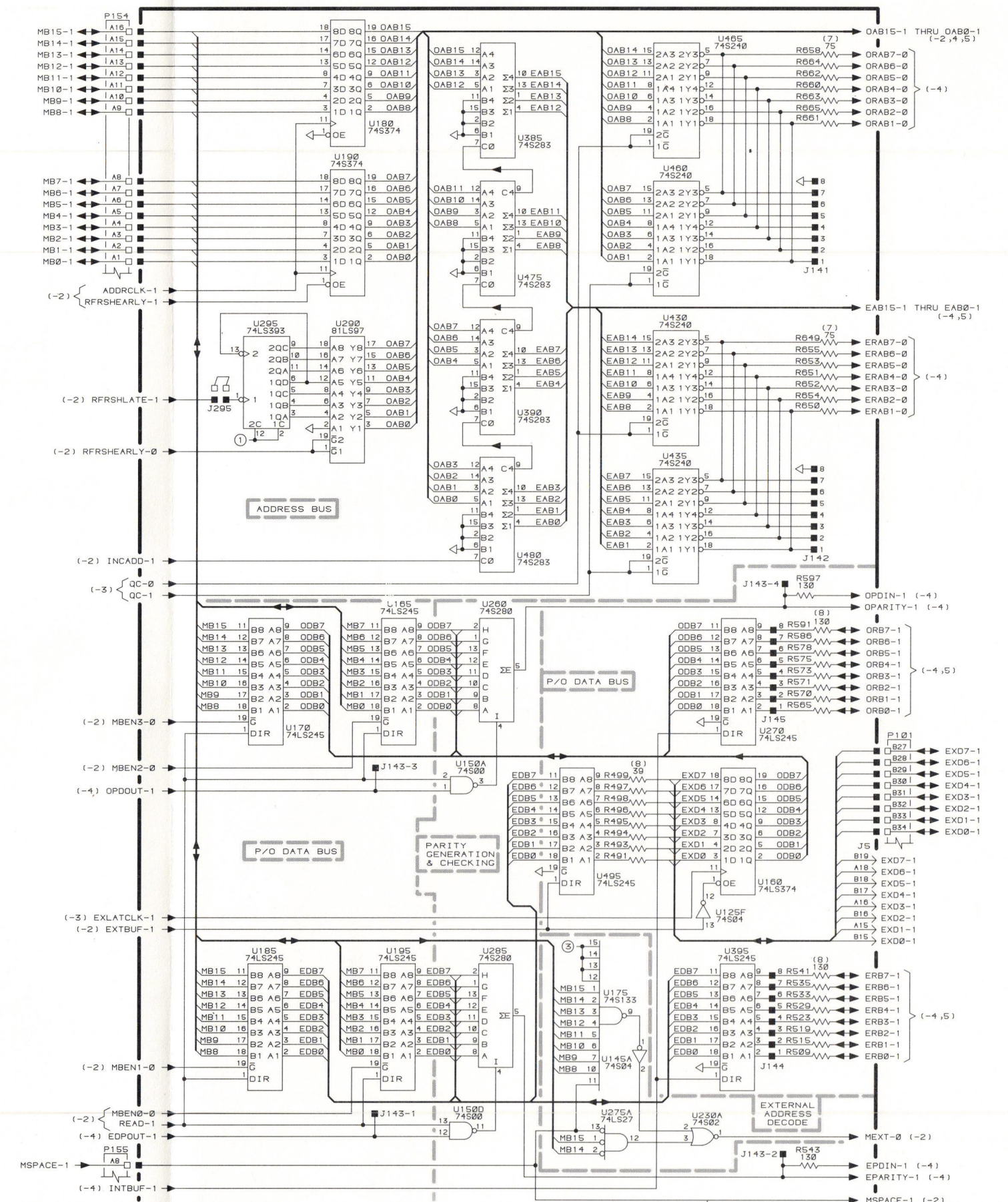

INSTRUMENT: 4052	NOTES:	REV, JULY 1982 2029-512	BOARD: 670-6030-00 & UP MEMORY ACCESS SEQUENCER	ASSEMBLY-SHEET: A4-1 (1 OF 5)
---------------------	--------	----------------------------	--	-------------------------------------

4052 MAS BOARD AND UP A4-1

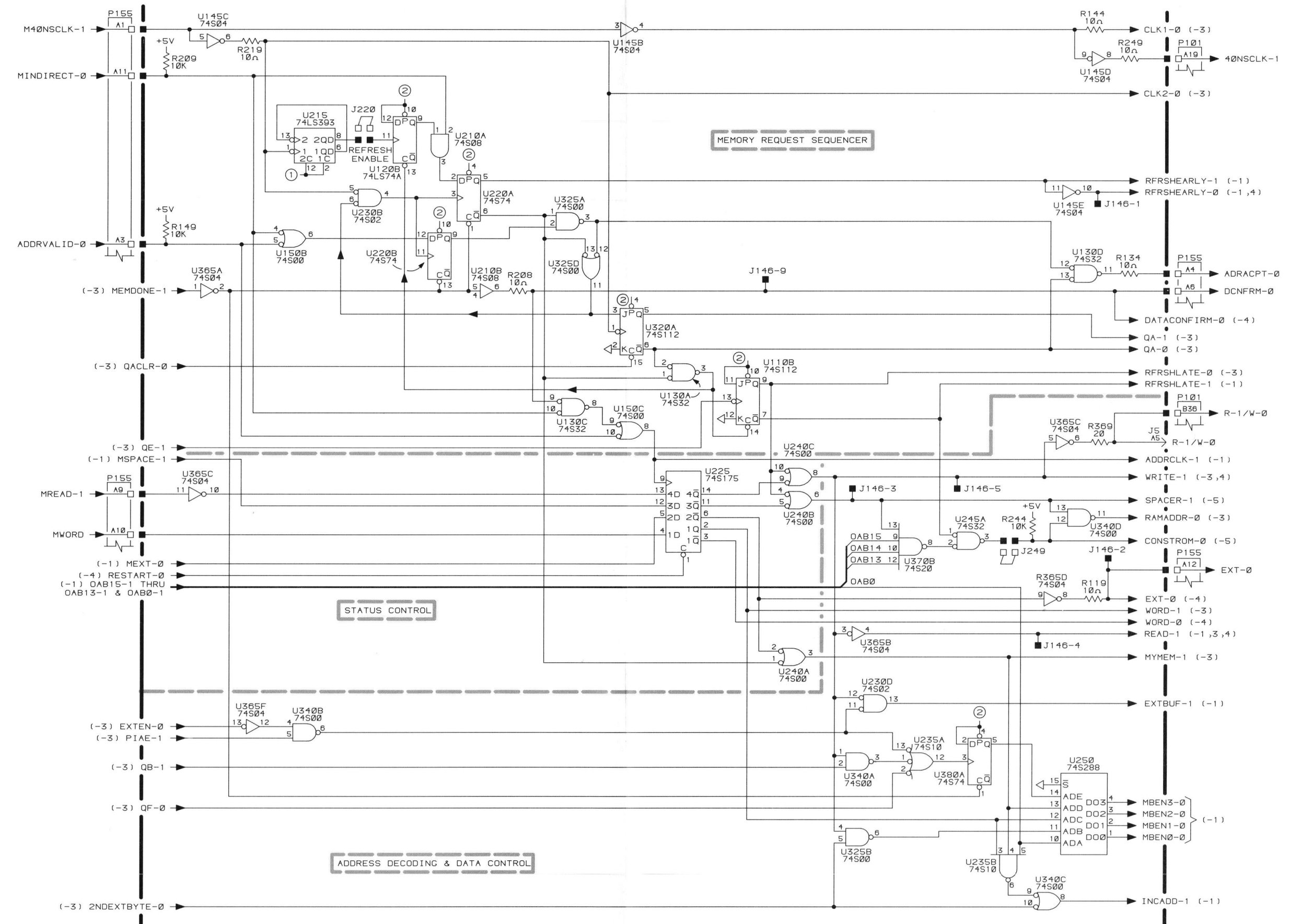

INSTRUMENT: 4052	NOTES: 	REV, JULY 1982 2829-S13	BOARD: 670-6030-00 & UP MEMORY ACCESS SEQUENCER	ASSEMBLY-SHEET: A4-2 (2 OF 5)
---------------------	----------------	----------------------------	--	-------------------------------------

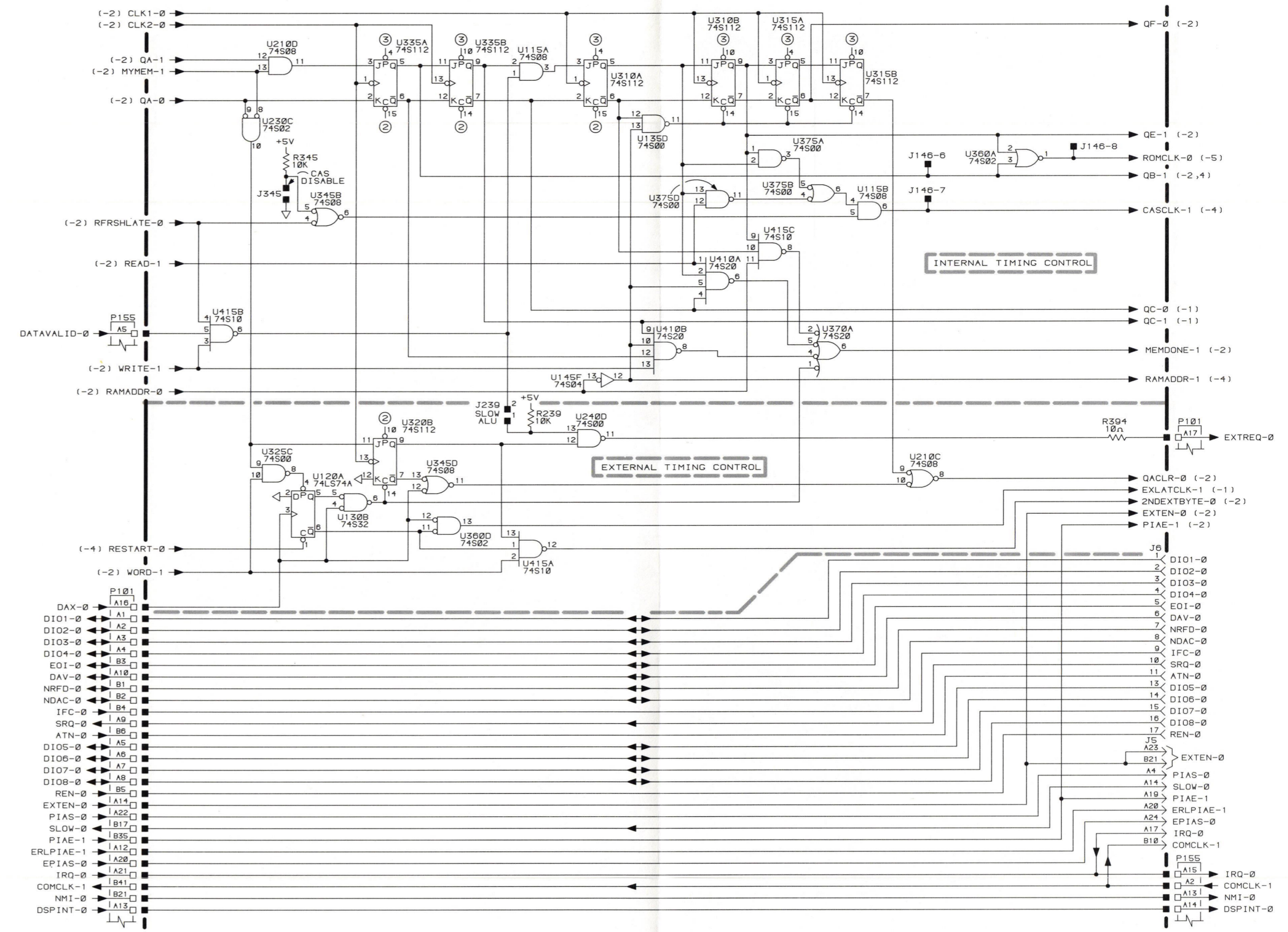

INSTRUMENT: 4052	NOTES:	REV, JULY 1982 2829-S14	BOARD: 670-6030-00 & UP MEMORY ACCESS SEQUENCER	ASSEMBLY-SHEET: A4-3 (3 OF 5)
---------------------	--------	----------------------------	--	-------------------------------------

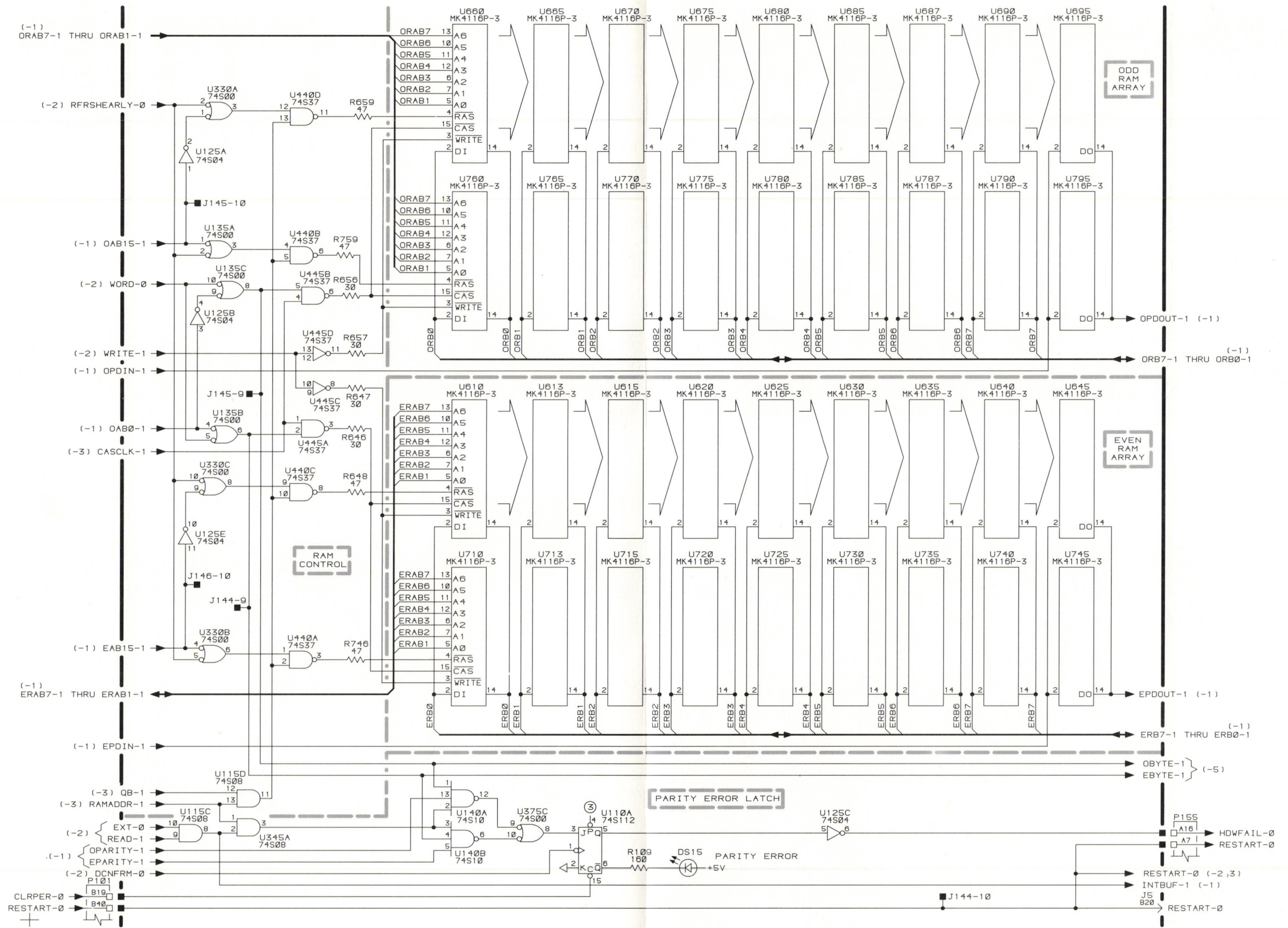

INSTRUMENT: 4052	NOTES: REV, JULY 1982 2829-S15	BOARD: 670-6030-00 & UP MEMORY ACCESS SEQUENCER	ASSEMBLY-SHEET: A4-4 (4 OF 5)
---------------------	--------------------------------------	--	-------------------------------------

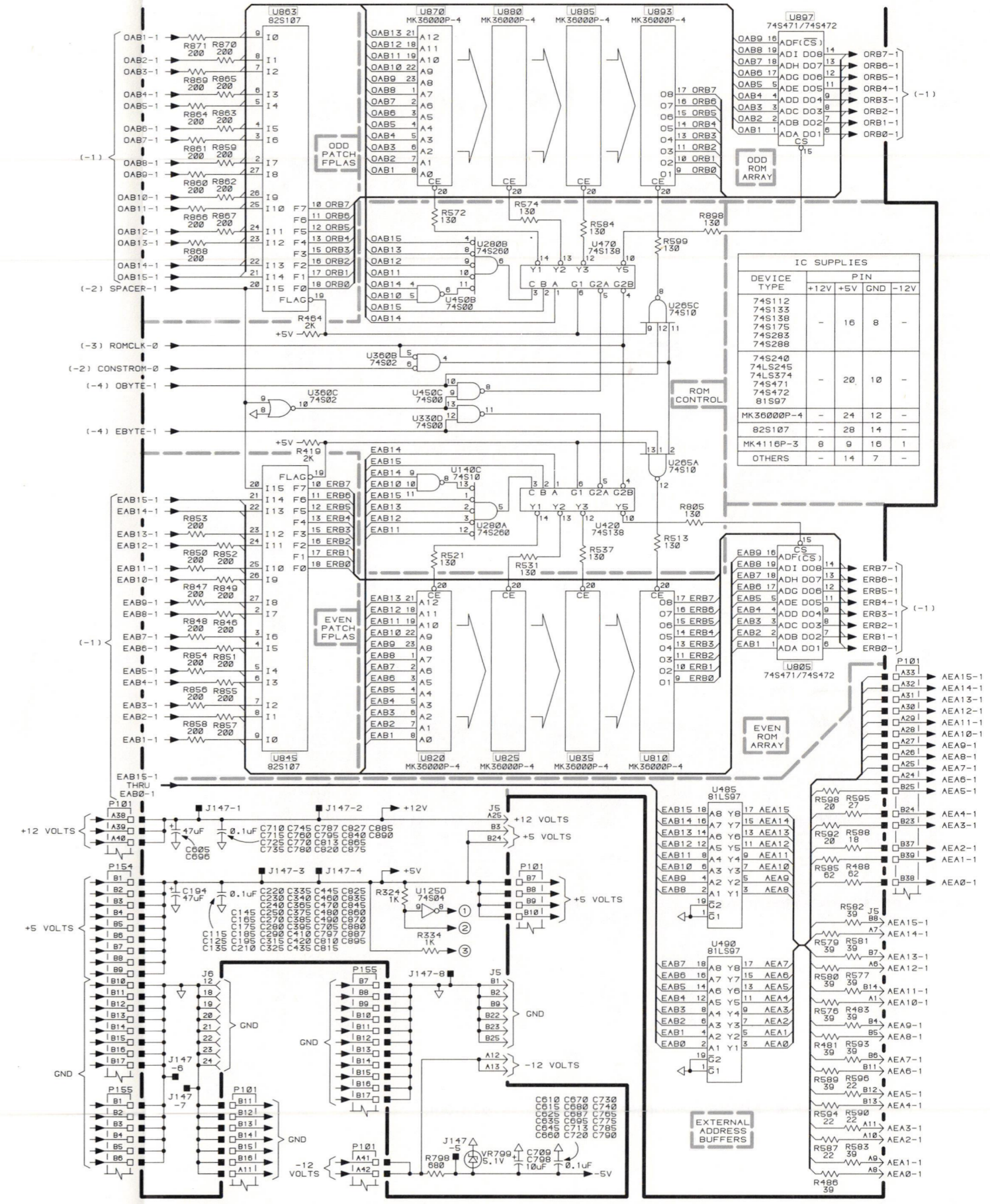

INSTRUMENT: 4052
 NOTES: SEE PARTS LIST FOR EARLIER VALUES AND SERIAL NUMBER RANGES OF PARTS OUTLINED OR DEPICTED IN GREY.
 BOARD: 670-6030-00 & UP
 REV, JULY 1982
 2829-516
 MEMORY ACCESS SEQUENCER
 ASSEMBLY-SHEET: A4-5 (5 OF 5)

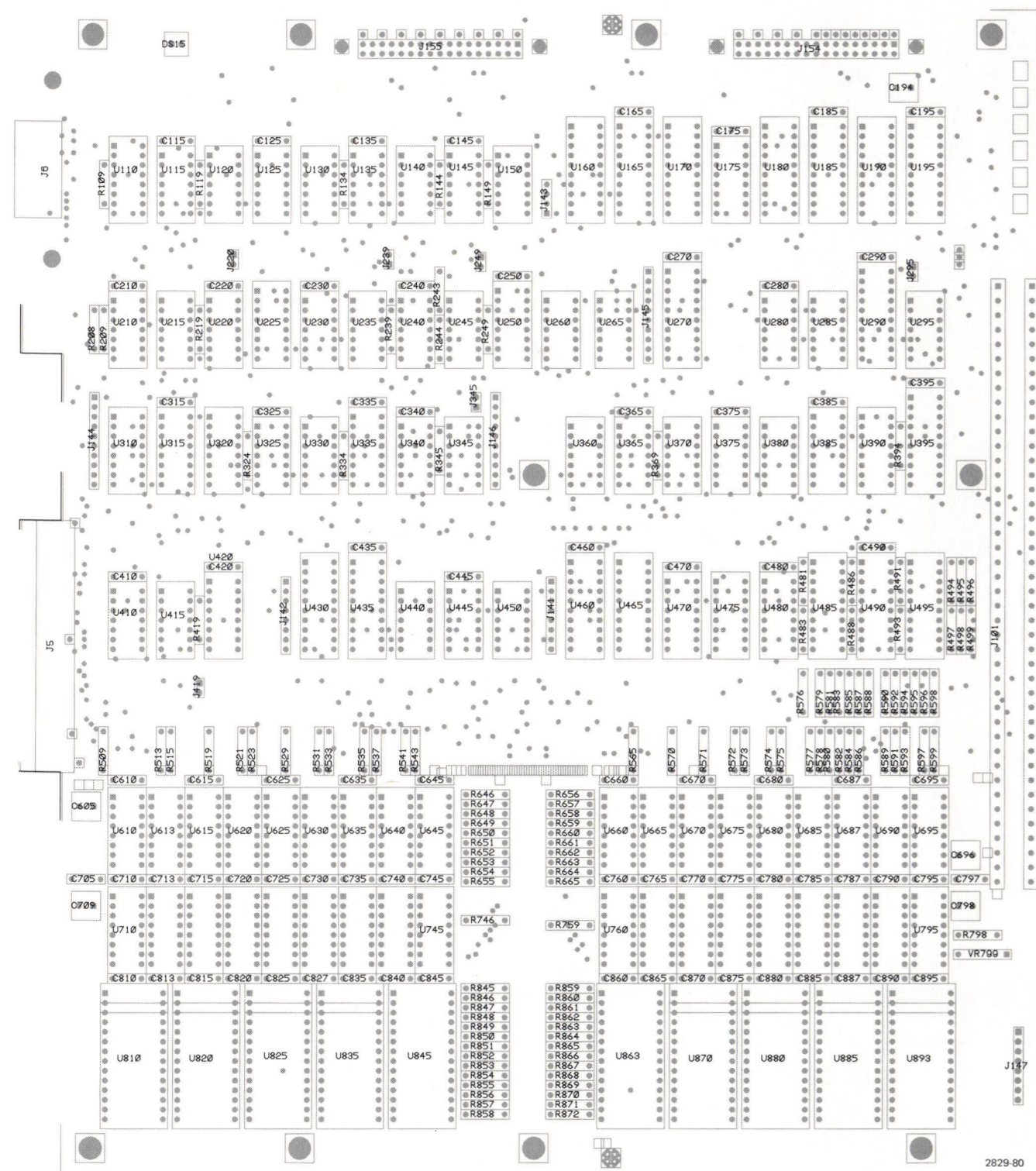

4052A MAS Board Component Locations (670-7624-00).

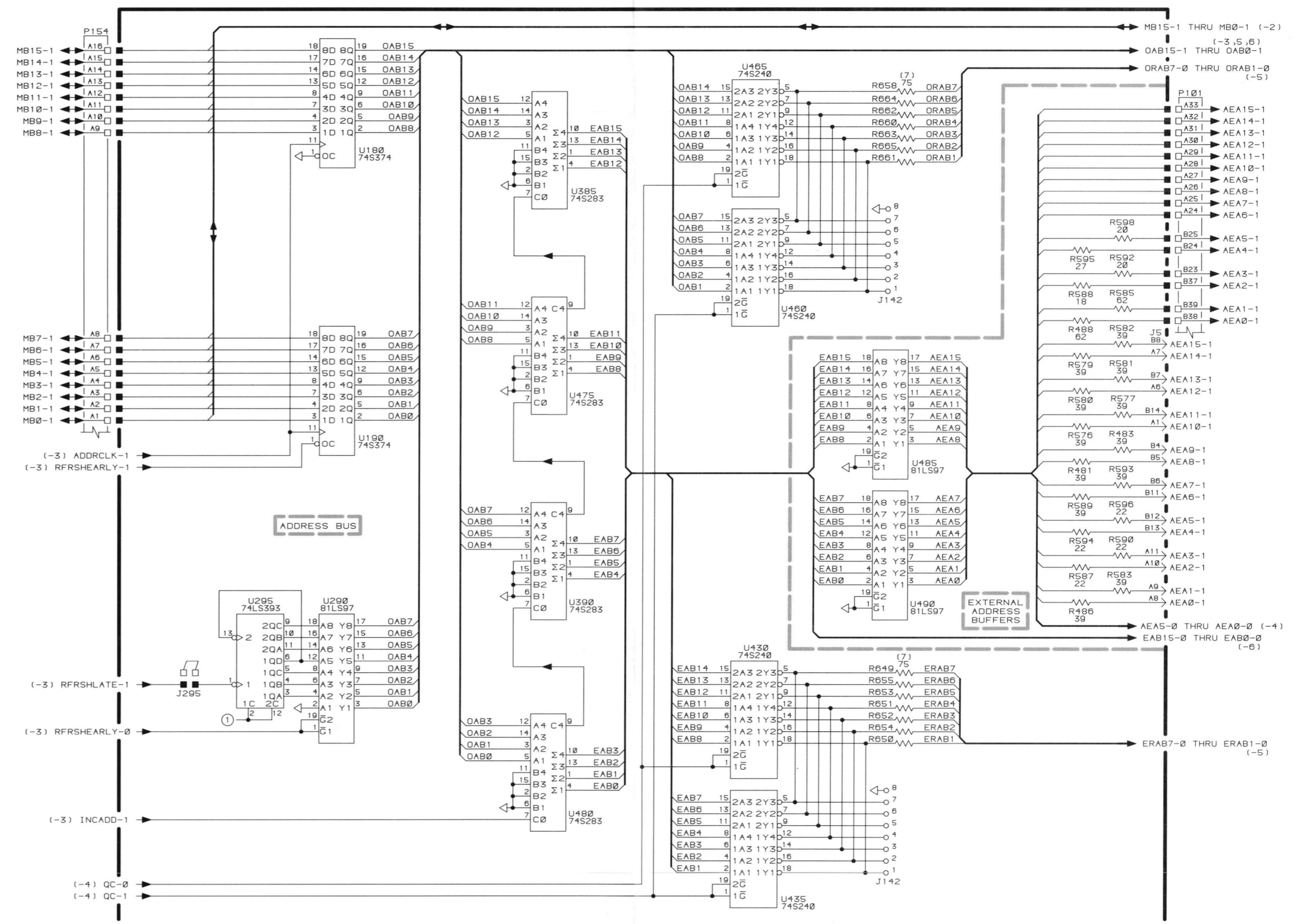

INSTRUMENT: 4052A	NOTES:	ADD, JULY 1982 2829-S17	BOARD: 670-7624-00 MEMORY ACCESS SEQUENCER	ASSEMBLY-SHEET: A4-1 (1 OF 7)
----------------------	--------	----------------------------	---	-------------------------------------

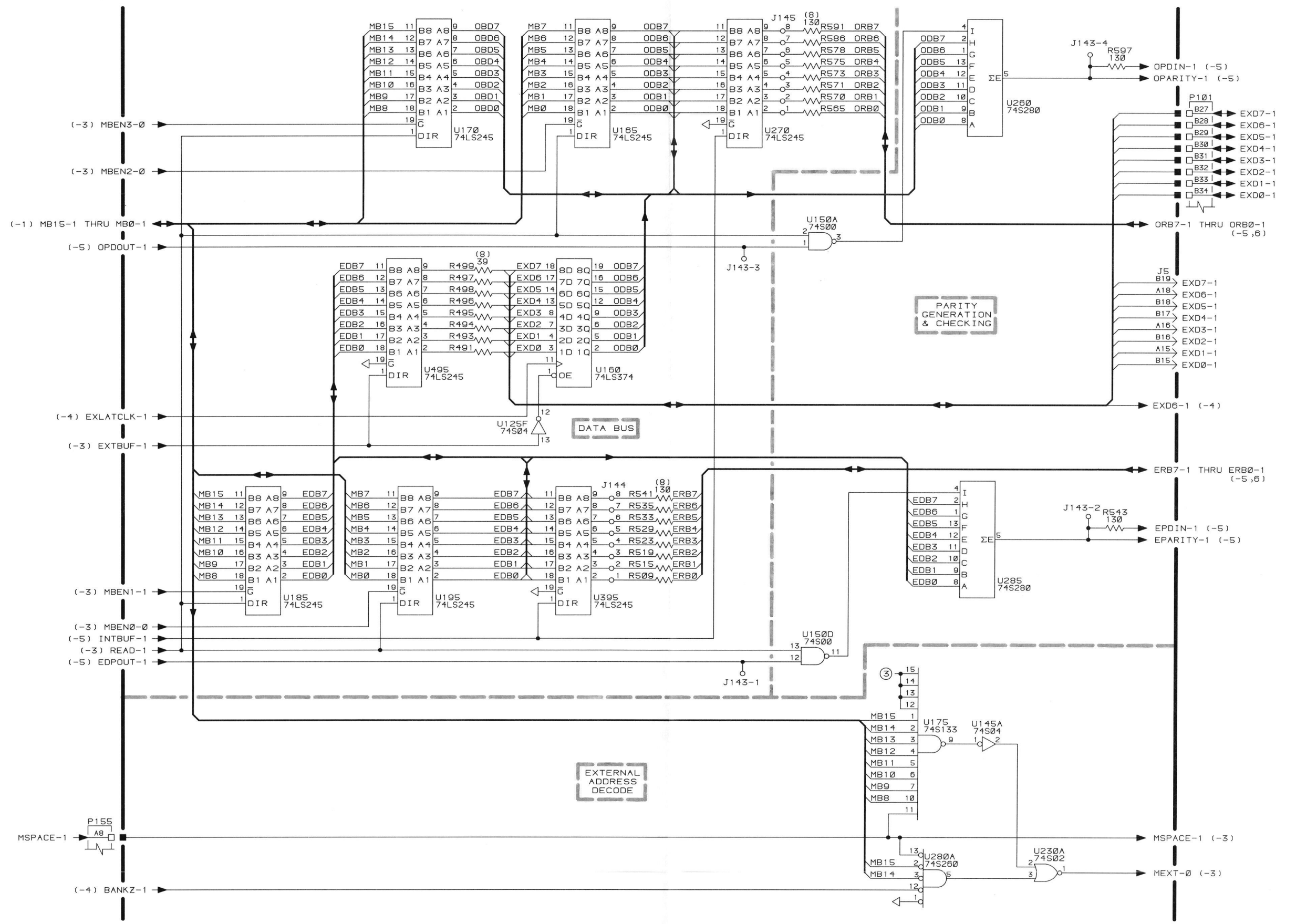

INSTRUMENT: 4052A	NOTES:	ADD, JULY 1982 2829-S18	BOARD: 670-7624-00 MEMORY ACCESS SEQUENCER	ASSEMBLY-SHEET: A4-2 (2 OF 7)
----------------------	--------	----------------------------	---	-------------------------------------

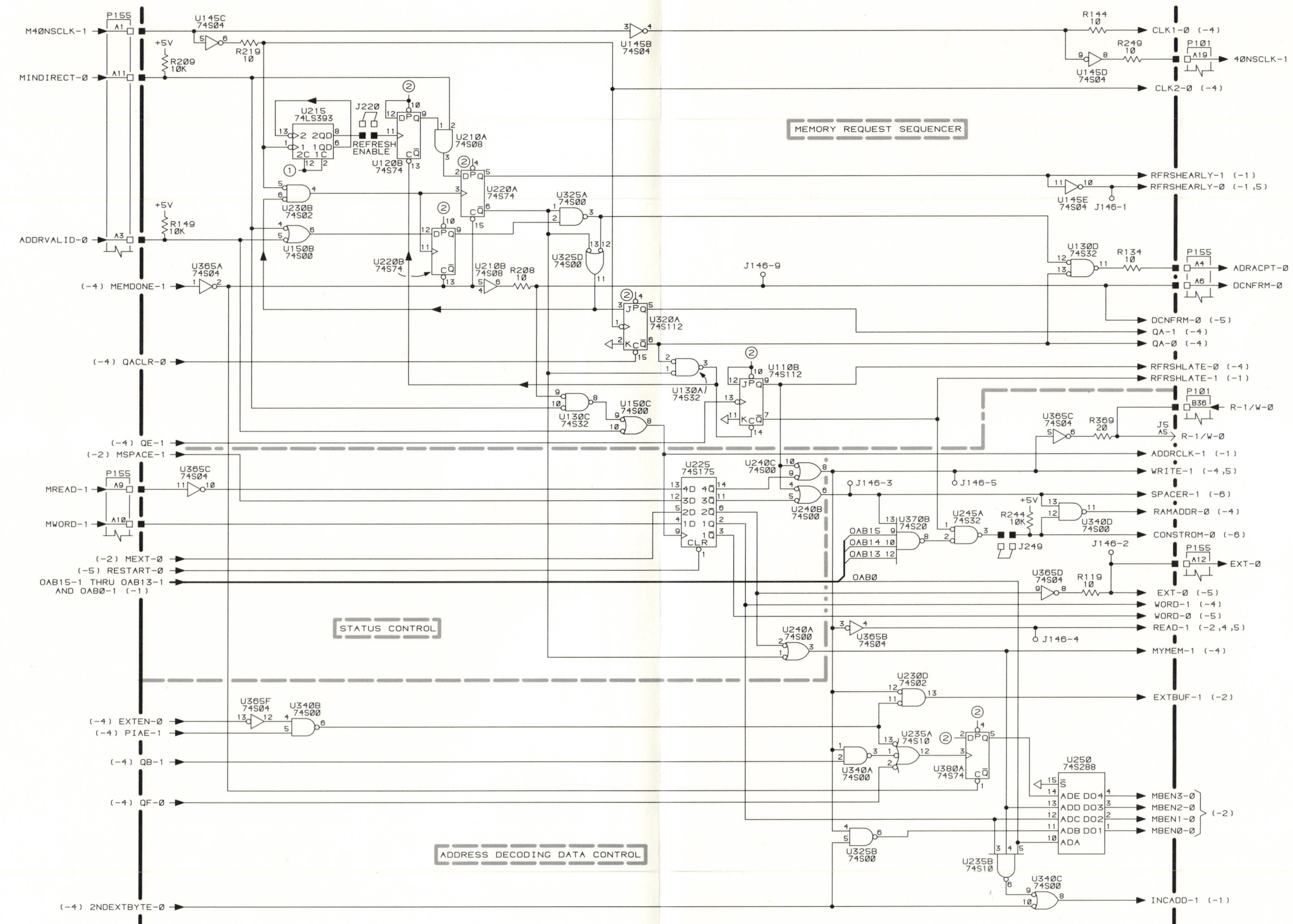

INSTRUMENT: 4052A	NOTES: ADD, JULY 1982 2829-S19	BOARD: 670-7624-00 MEMORY ACCESS SEQUENCER	ASSEMBLY-SHEET: A4-3 (3 OF 7)
----------------------	--------------------------------------	---	-------------------------------------

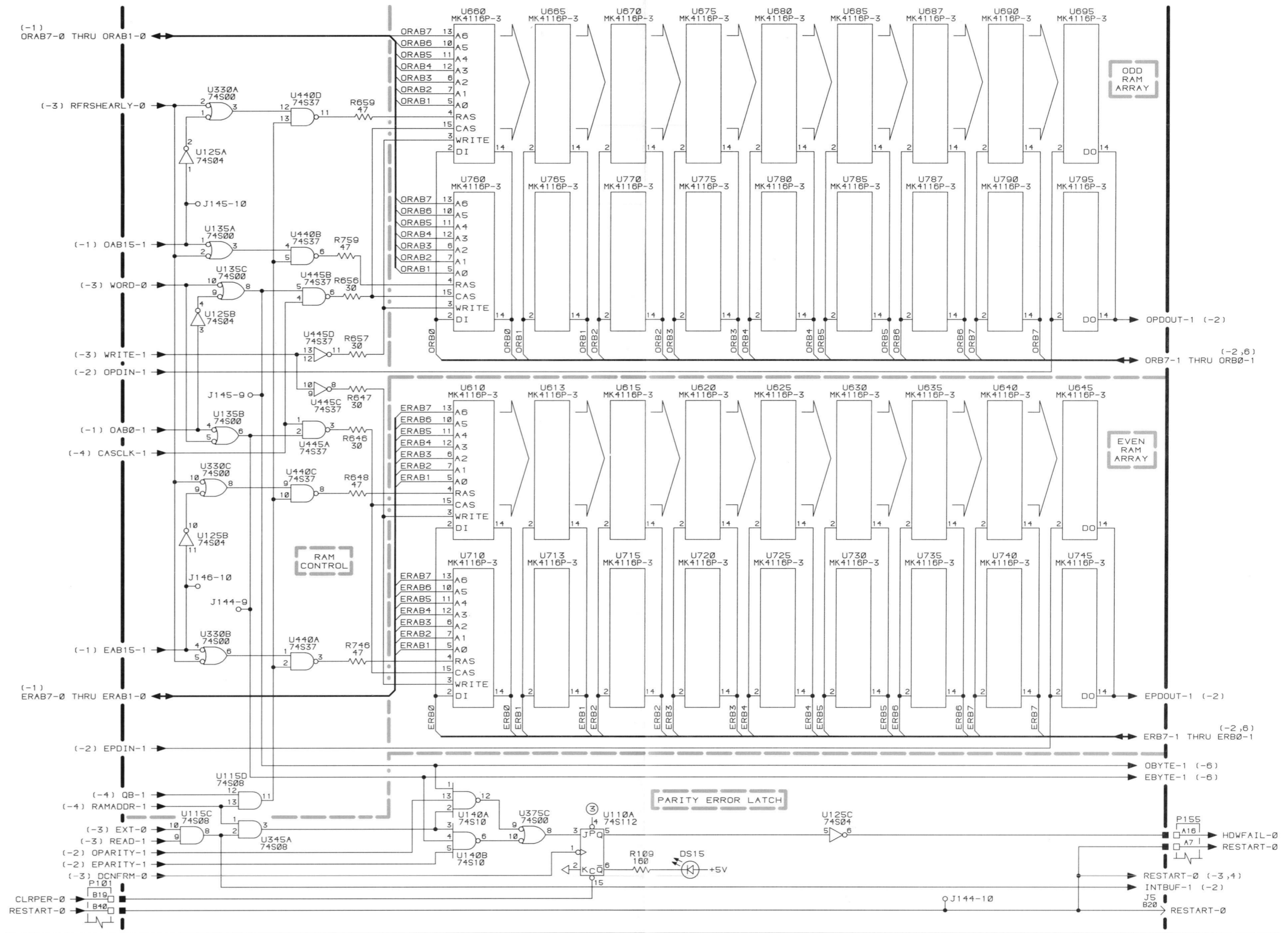

INSTRUMENT: 4052A	NOTES:	ADD, JULY 1982 2829-521	BOARD: 670-7624-00 MEMORY ACCESS SEQUENCER	ASSEMBLY-SHEET: A4-5 (5 OF 7)
----------------------	--------	----------------------------	---	-------------------------------------

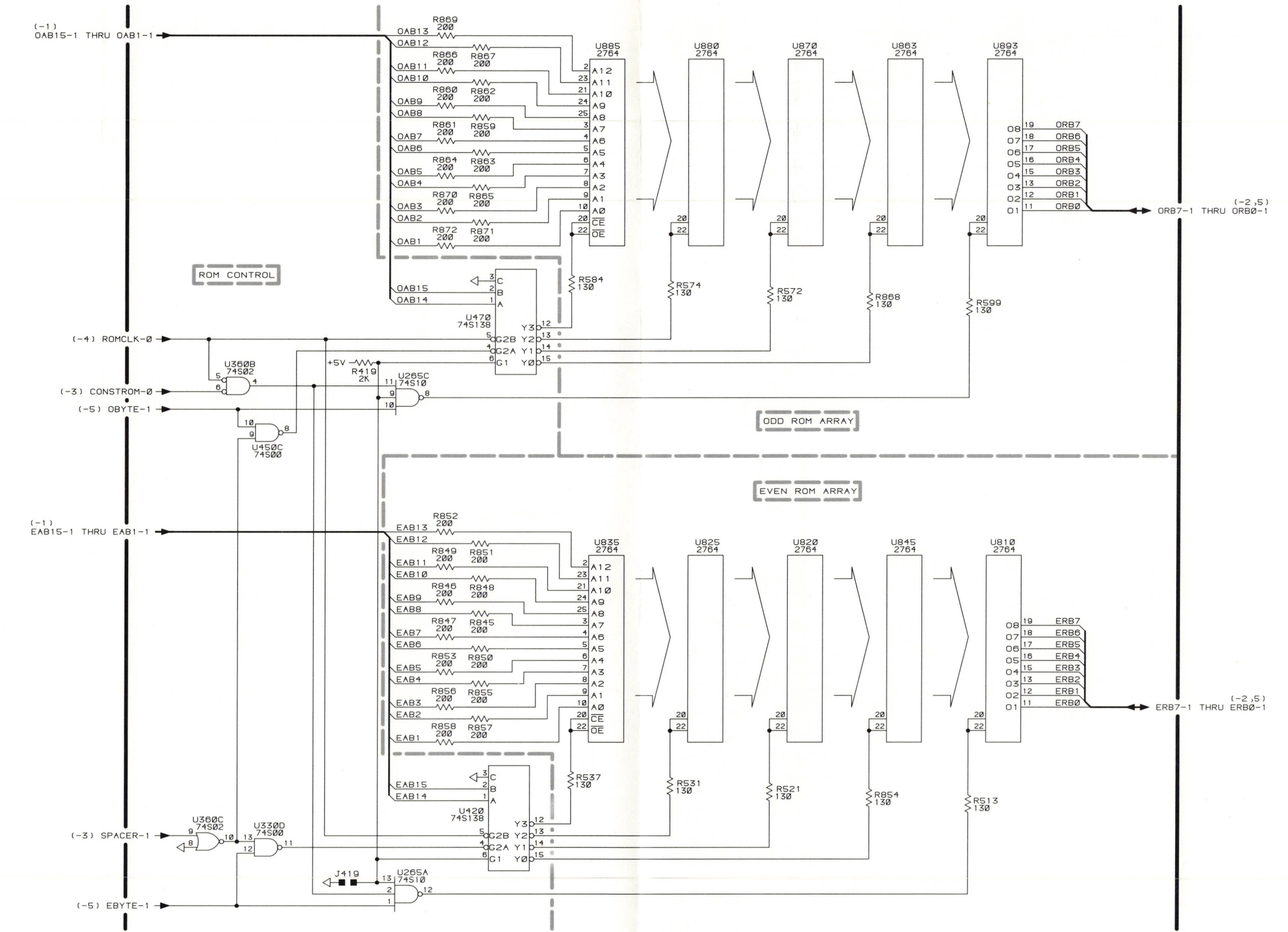

INSTRUMENT: 4052A	NOTES:	ADD, JULY 1982 2829-S22	BOARD: 670-7624-00 MEMORY ACCESS SEQUENCER	ASSEMBLY-SHEET: A4-6 (6 OF 7)
----------------------	--------	----------------------------	---	-------------------------------------

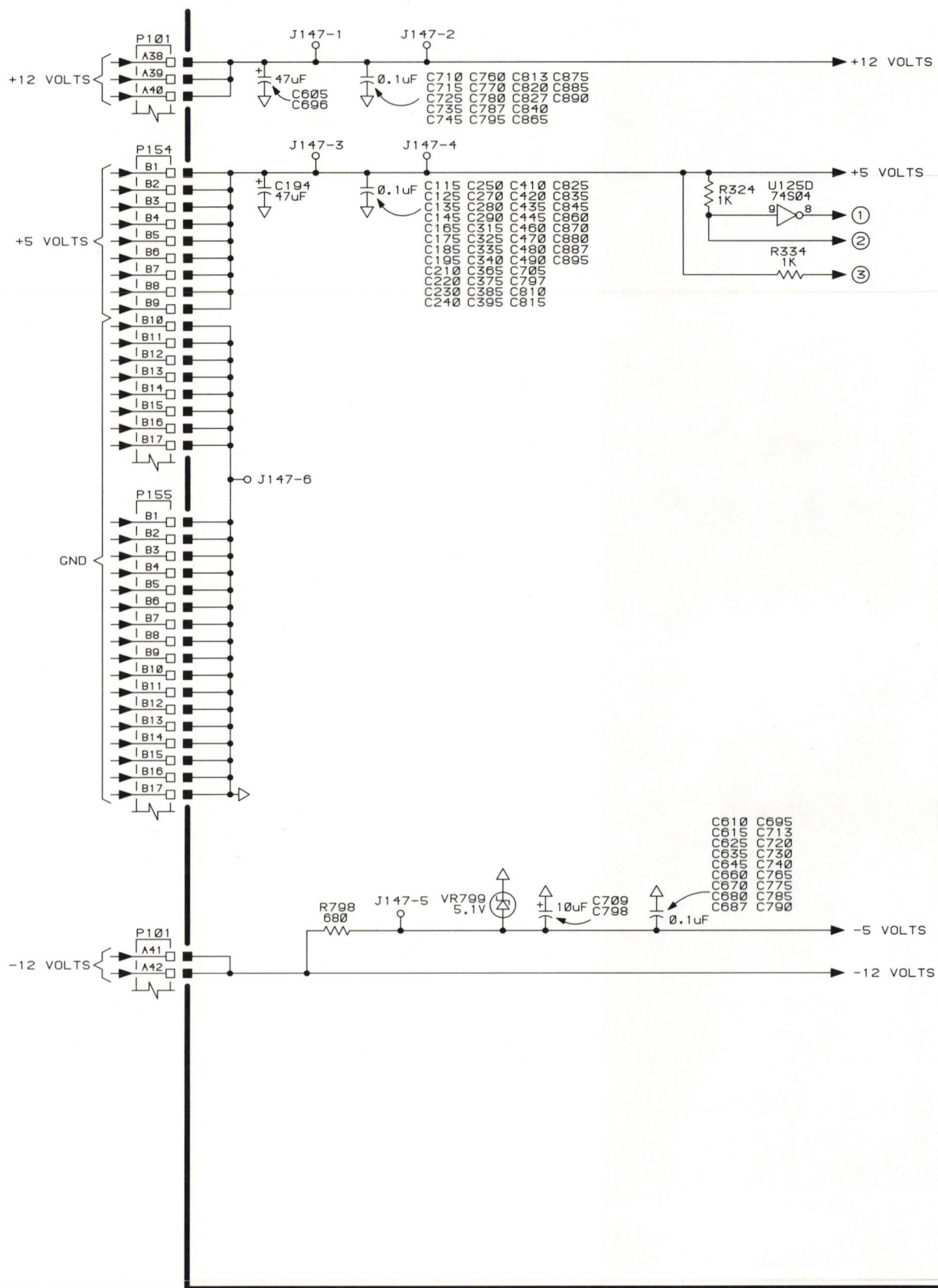

DEVICE TYPE	PIN			
	+12V	+5V	GND	-5V
74S112				
74S133				
74S138	-	16	8	-
74S175				
74S283				
74S288				
74S240				
74LS245				
74LS374				
81S97				
2764	-	1,26 27,28	14	-
MK4116P-3	8	9	16	1
OTHER 14 PIN IC'S	-	14	7	-

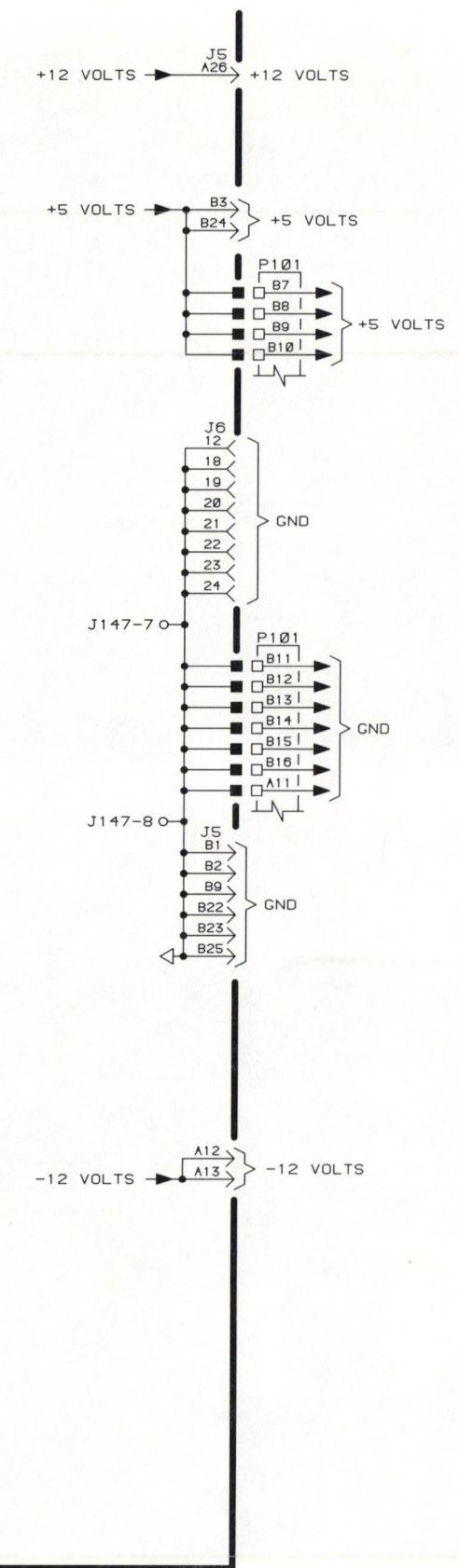

INSTRUMENT:
4052A

NOTES:

ADD, JULY 1982
2829-S23

BOARD: 870-7624-00
MEMORY ACCESS SEQUENCER

ASSEMBLY-SHEET:
A4-7
(7 OF 7)

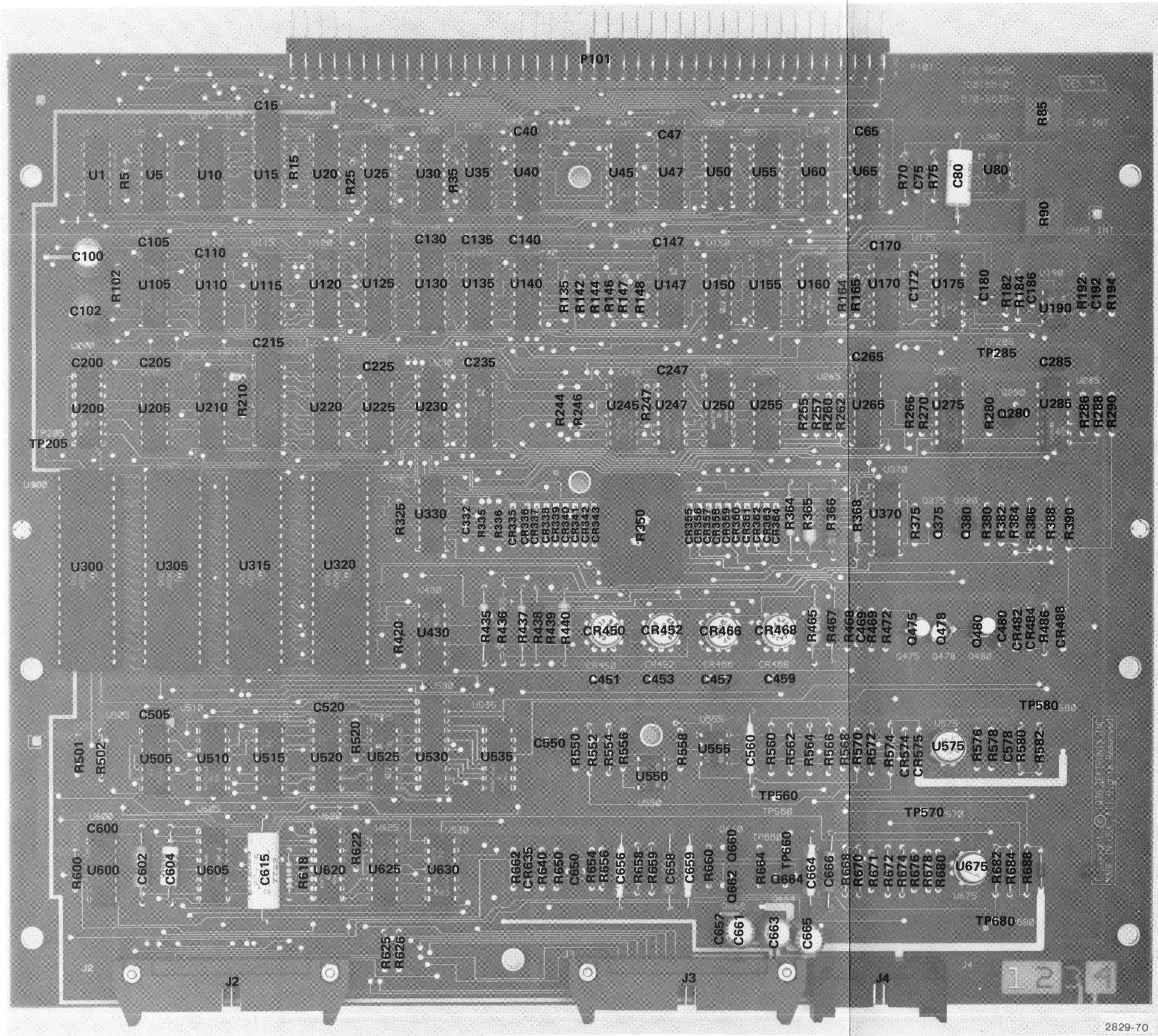

4052 I/O Board Component Locations (670-5632-00,01,02,03,04).

REV, JUL 1982

4052/4052A PARTS AND SCHEMATICS

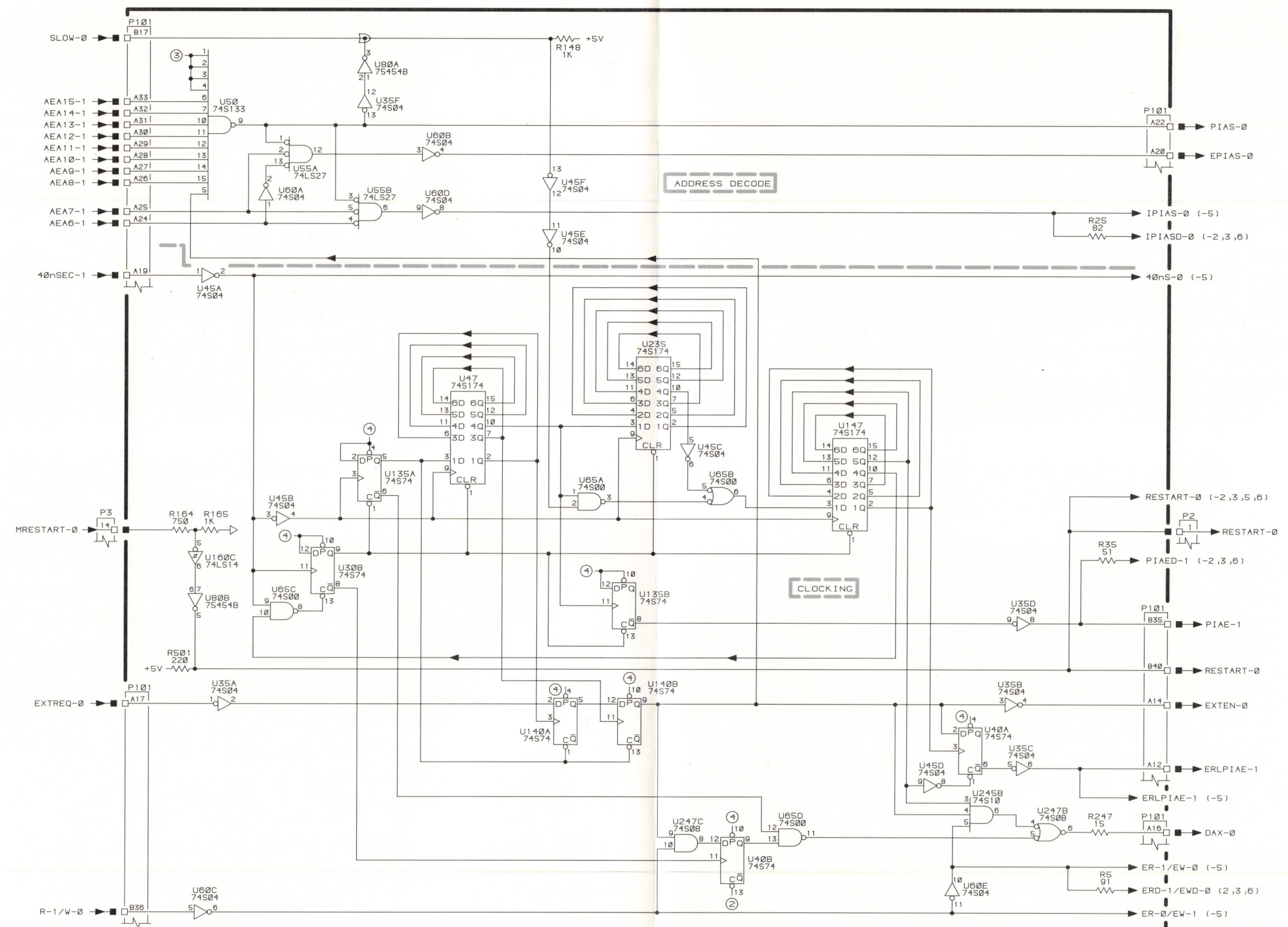

INSTRUMENT: 4052	NOTES:	REV, JULY 1982 2829-S24	BOARD: 670-5632-00,01,03,04 I/O BOARD	ASSEMBLY-SHEET: A5-1 (1 OF 6)
---------------------	--------	----------------------------	--	-------------------------------------

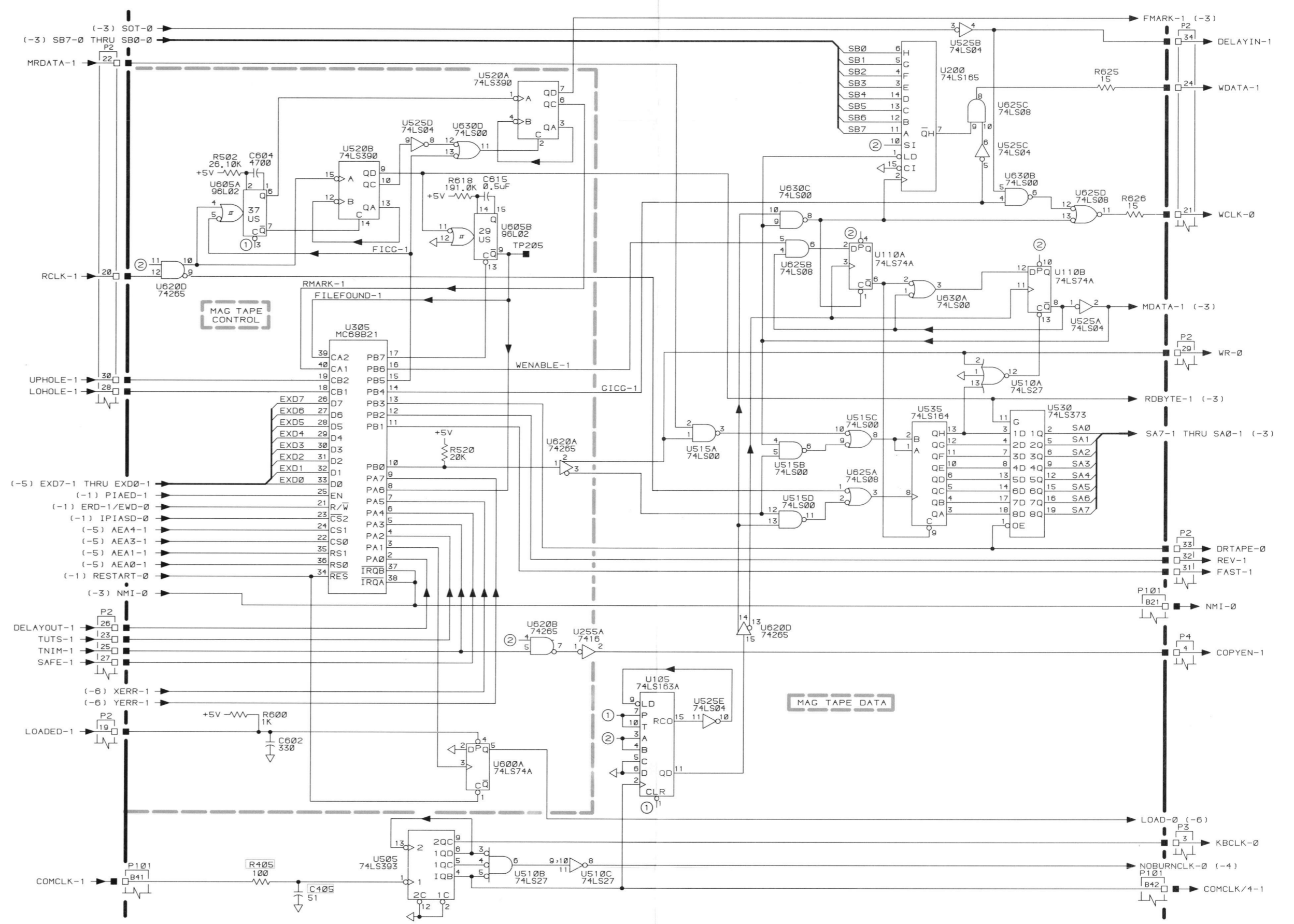

INSTRUMENT: 4052	NOTES: SEE PARTS LIST FOR EARLIER VALUES AND SERIAL NUMBER RANGES OF PARTS OUTLINED OR DEPICTED IN GREY.	REV, JULY 1982 2829-S25	BOARD: 670-5632-00,01,03,04 I/O BOARD	ASSEMBLY-SHEET: A5-2 (2 OF 6)
---------------------	--	----------------------------	--	-------------------------------------

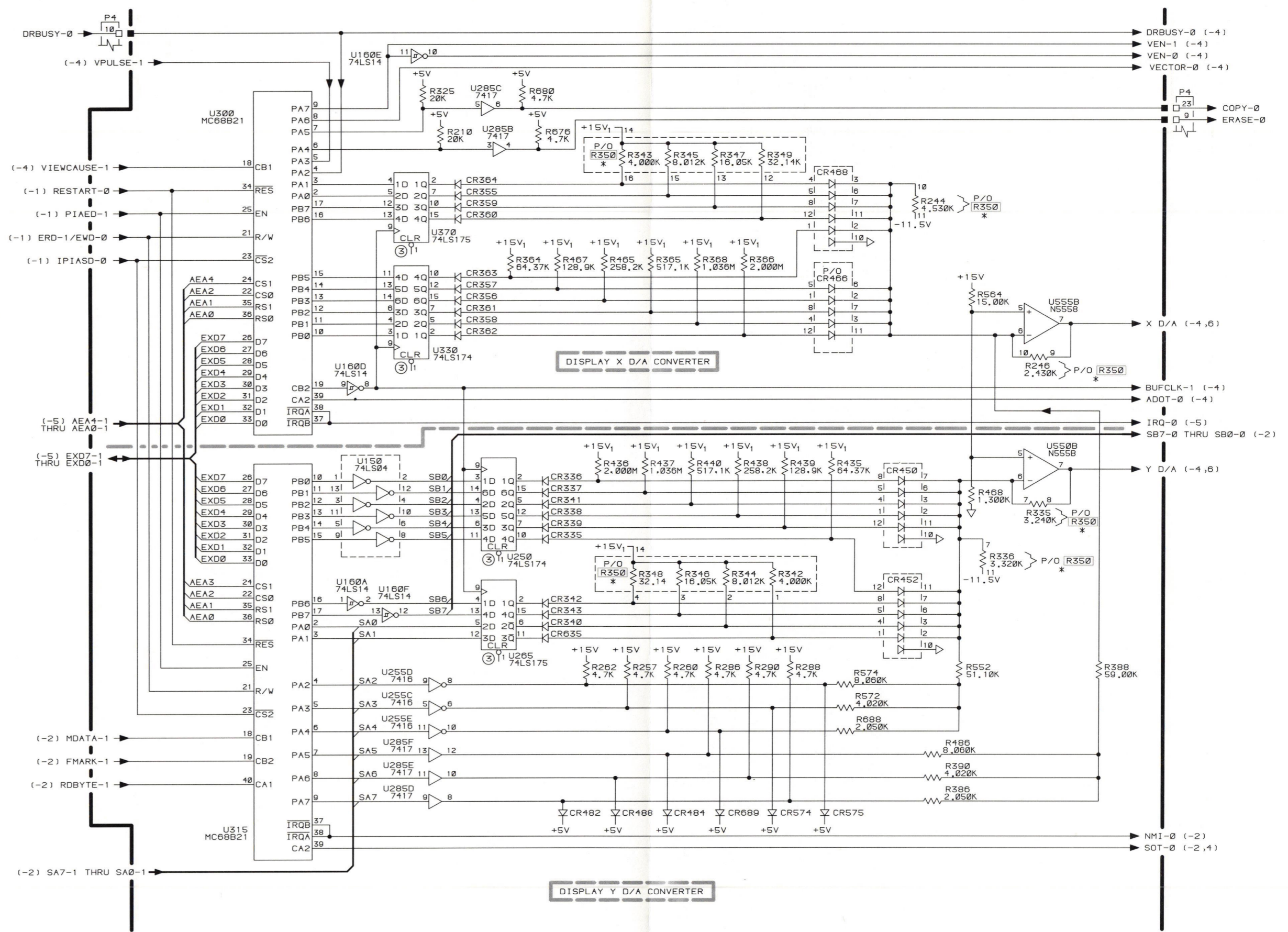

INSTRUMENT: <p style="text-align: center;">4052</p>	NOTES: *R350 MAY BE USED INSTEAD OF DISCRETE RESISTORS. <small>SEE PARTS LIST FOR EARLIER VALUES AND SERIAL NUMBER RANGES OF PARTS OUTLINED OR DEPICTED IN GREY.</small>	REV: JULY 1982 <p style="text-align: center;">2829-S26</p>	BOARD: 670-5632-00,01,03,04 <p style="text-align: center;">I/O BOARD</p>	ASSEMBLY-SHEET: <p style="text-align: center;">A5-3 (3 OF 6)</p>
--	---	---	---	---

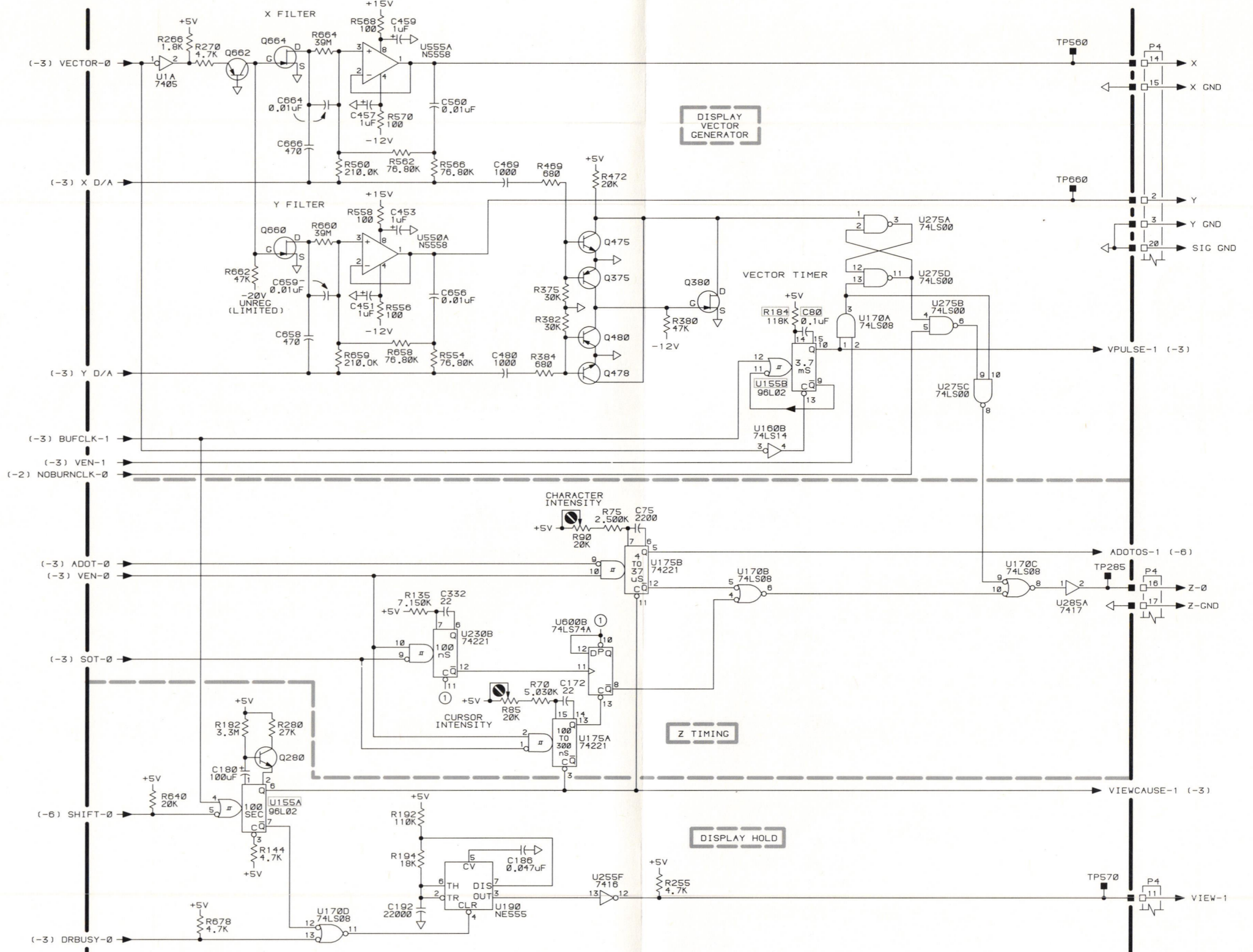

INSTRUMENT: 4052	NOTES: SEE PARTS LIST FOR EARLIER VALUES AND SERIAL NUMBER RANGES OF PARTS OUTLINED OR DEPICTED IN GREY.	REV, JULY 1982 2829-S27	BOARD: 670-5632-00,01,03,04 I/O BOARD	ASSEMBLY-SHEET: AS-4 (4 OF 6)
---------------------	--	----------------------------	--	-------------------------------------

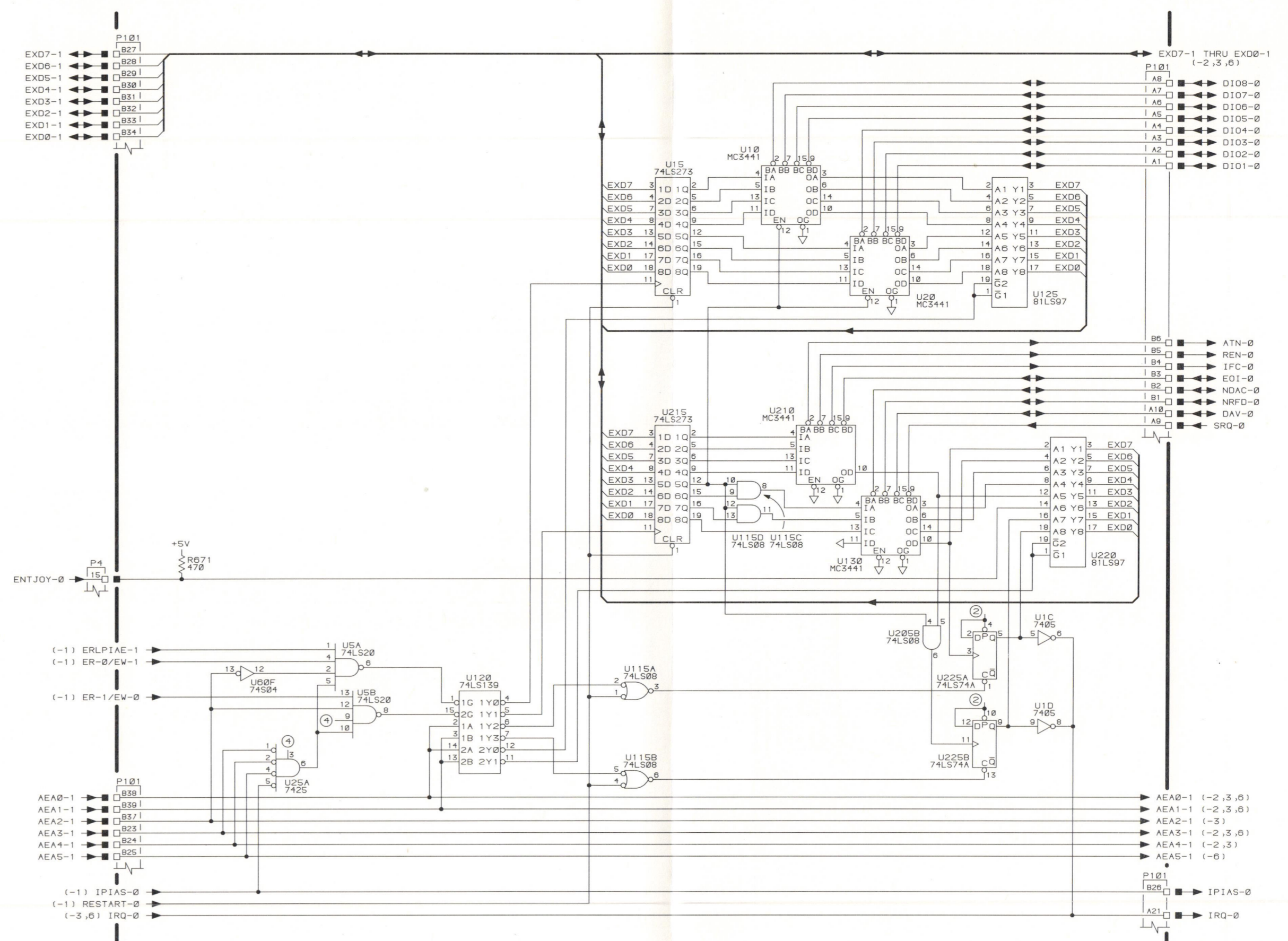

INSTRUMENT: 4052	NOTES:	REV, JULY 1982 2829-S28	BOARD: 670-5632-00,01,03,04 I/O BOARD GPIB INTERFACE	ASSEMBLY-SHEET: A5-5 (5 OF 6)
---------------------	--------	----------------------------	--	-------------------------------------

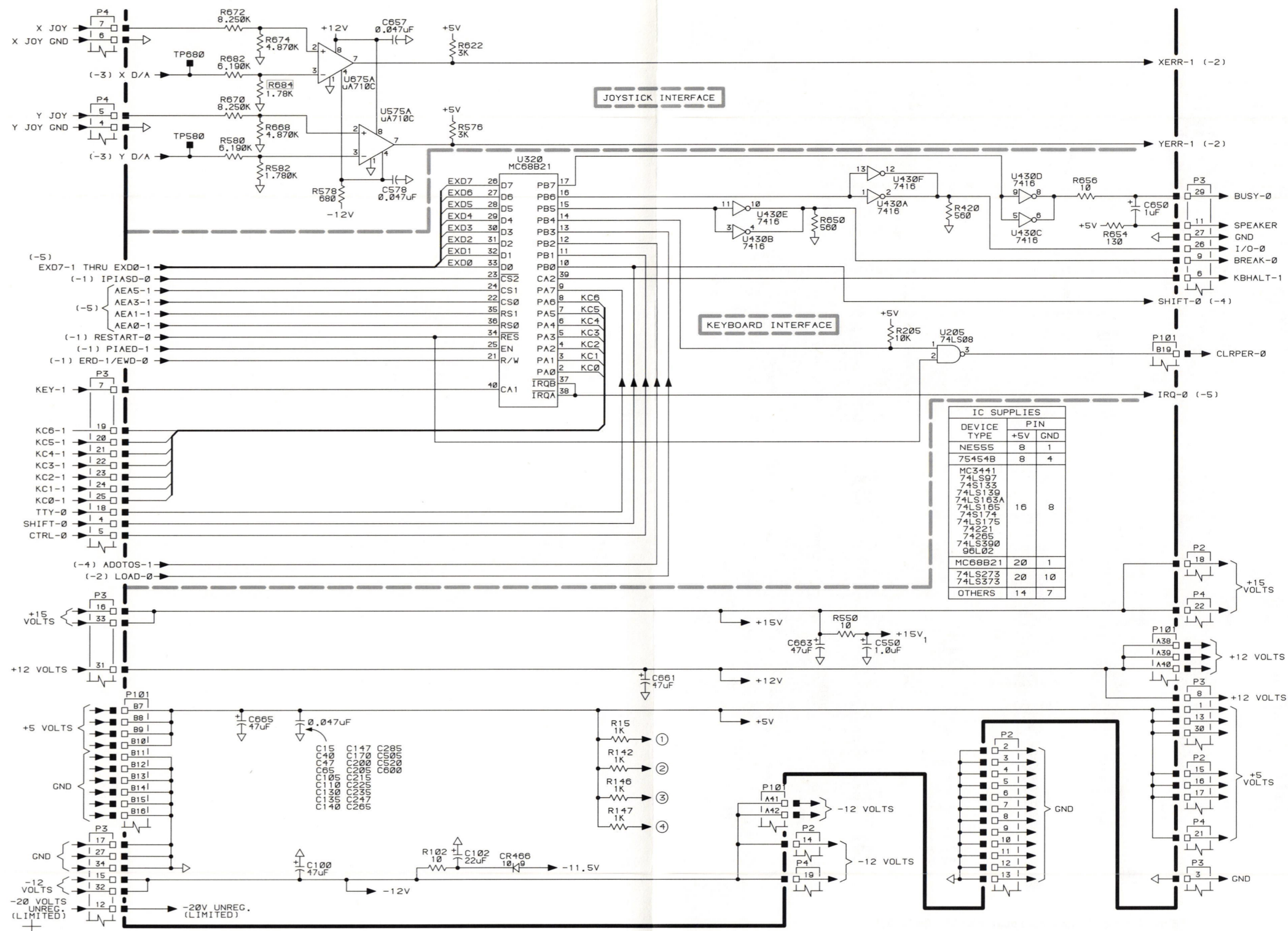

IC SUPPLIES		
DEVICE TYPE	+5V	GND
NE555	8	1
75454B	8	4
MC3441		
74LS97		
74LS133		
74LS139		
74LS163A		
74LS165	16	8
74LS174		
74LS175		
74221		
74265		
74LS300		
96L02		
MC68B21	20	1
74LS273	20	10
74LS373		
OTHERS	14	7

INSTRUMENT: 4052

NOTES: SEE PARTS LIST FOR EARLIER VALUES AND SERIAL NUMBER RANGES OF PARTS OUTLINED OR DEPICTED IN GREY.

REV, JULY 1982
2829-S29

BOARD: 670-5632-00,01,03,04

I/O BOARD

ASSEMBLY-SHEET:
A5-6
(6 OF 6)

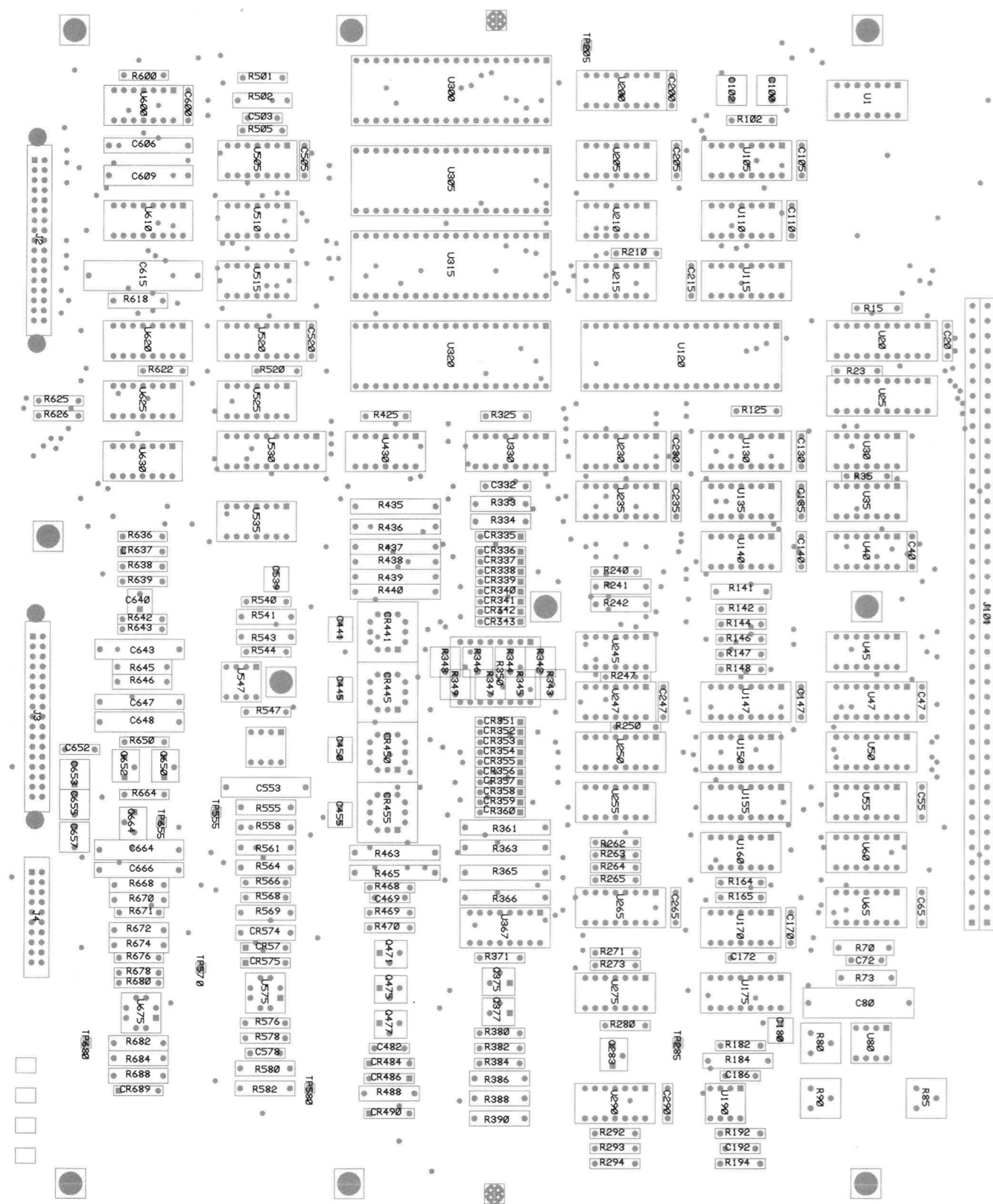

4052A I/O Board Component Locations (670-7629-00).

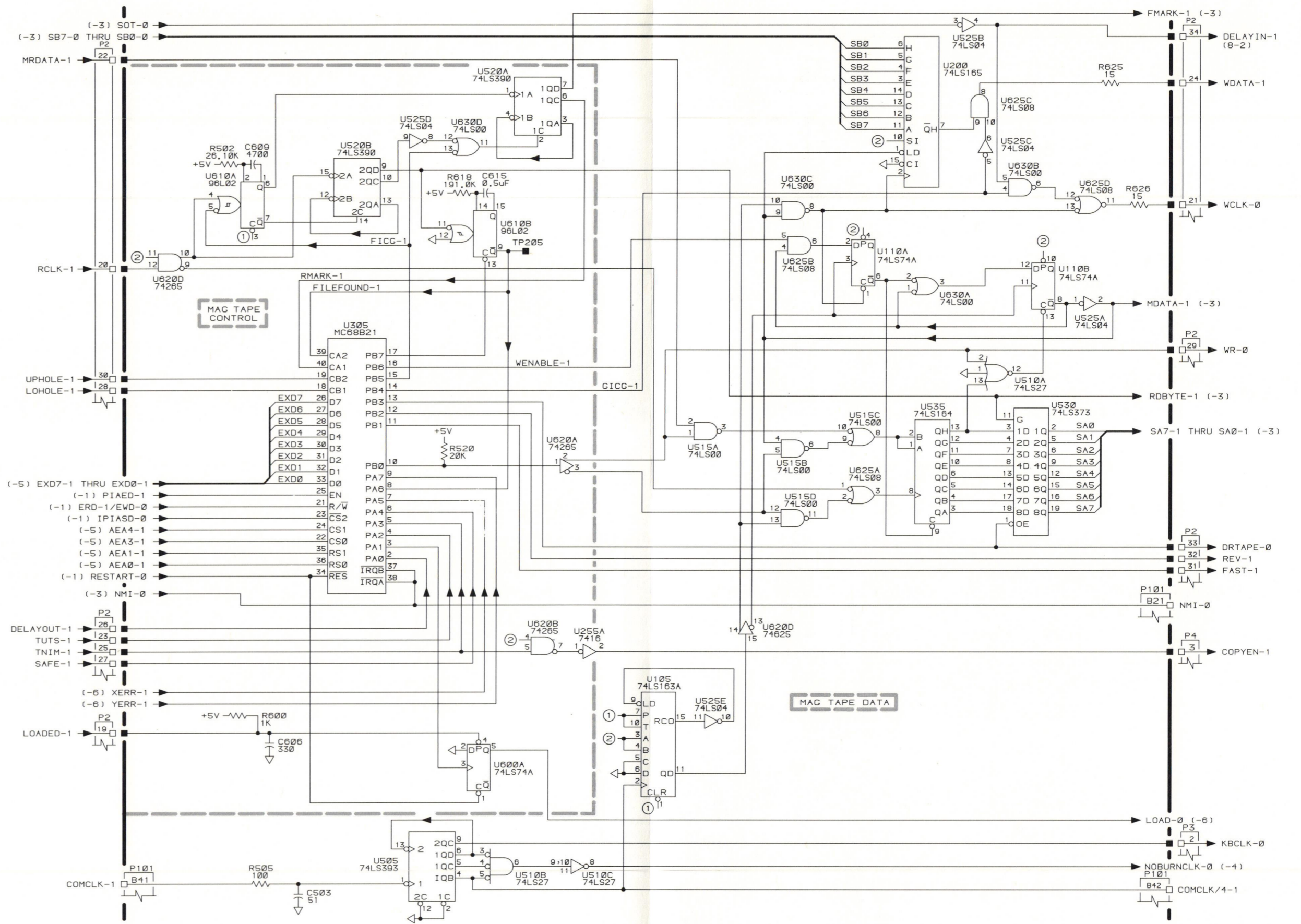

INSTRUMENT: 4052A	NOTES:	ADD, JULY 1982 2829-S31	BOARD: 670-7629-00 I/O BOARD	ASSEMBLY-SHEET: A5-2 (2 OF 6)
----------------------	--------	----------------------------	---------------------------------	-------------------------------------

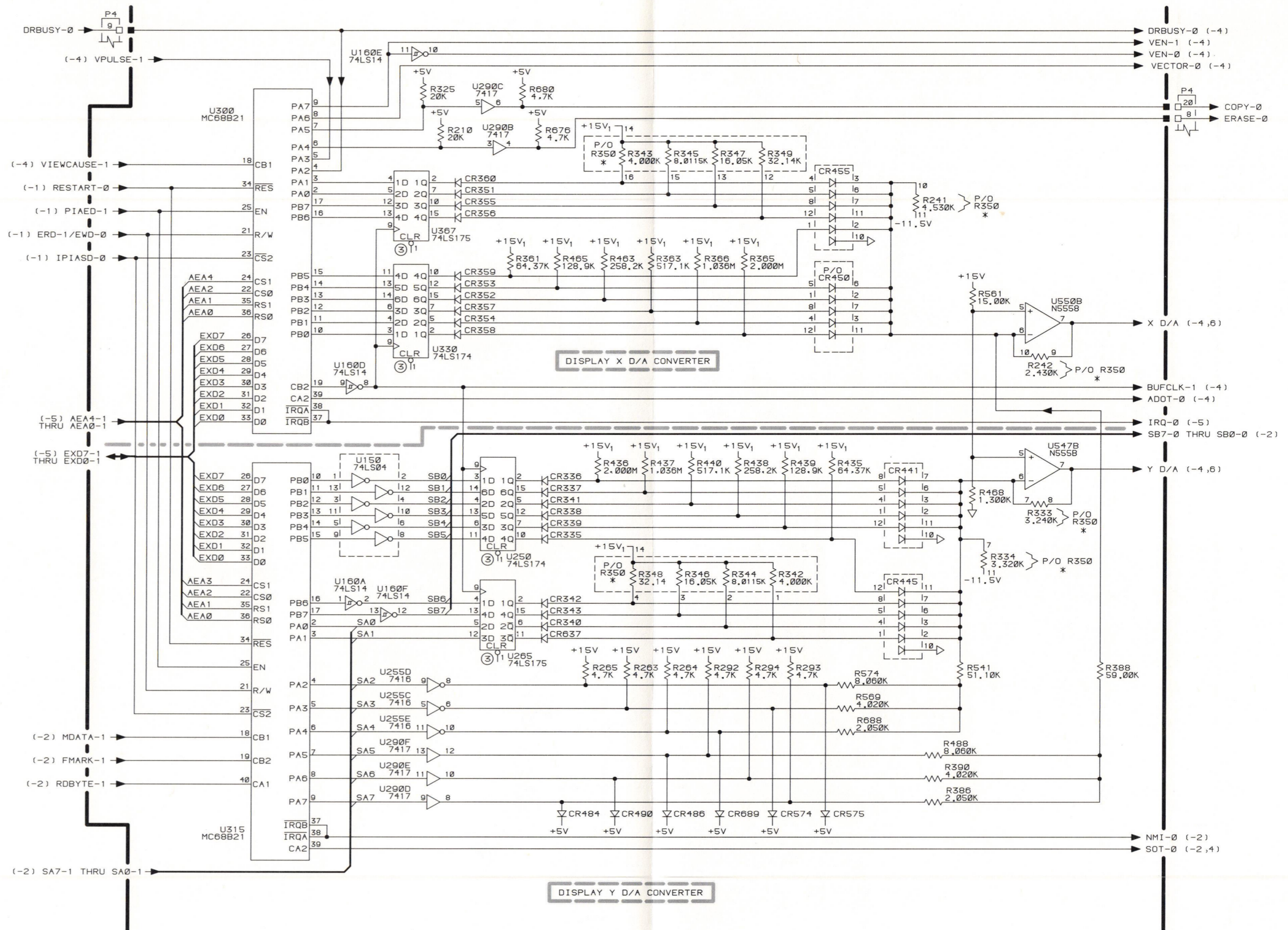

INSTRUMENT: 4052A	NOTES: *R350 MAY BE USED INSTEAD OF DISCRETE RESISTORS. ADD, JULY 1982 2829-532	BOARD: 670-7629-00	ASSEMBLY-SHEET: I/O BOARD A5-3 (3 OF 6)
----------------------	---	--------------------	--

4052A I/O BOARD A5-3

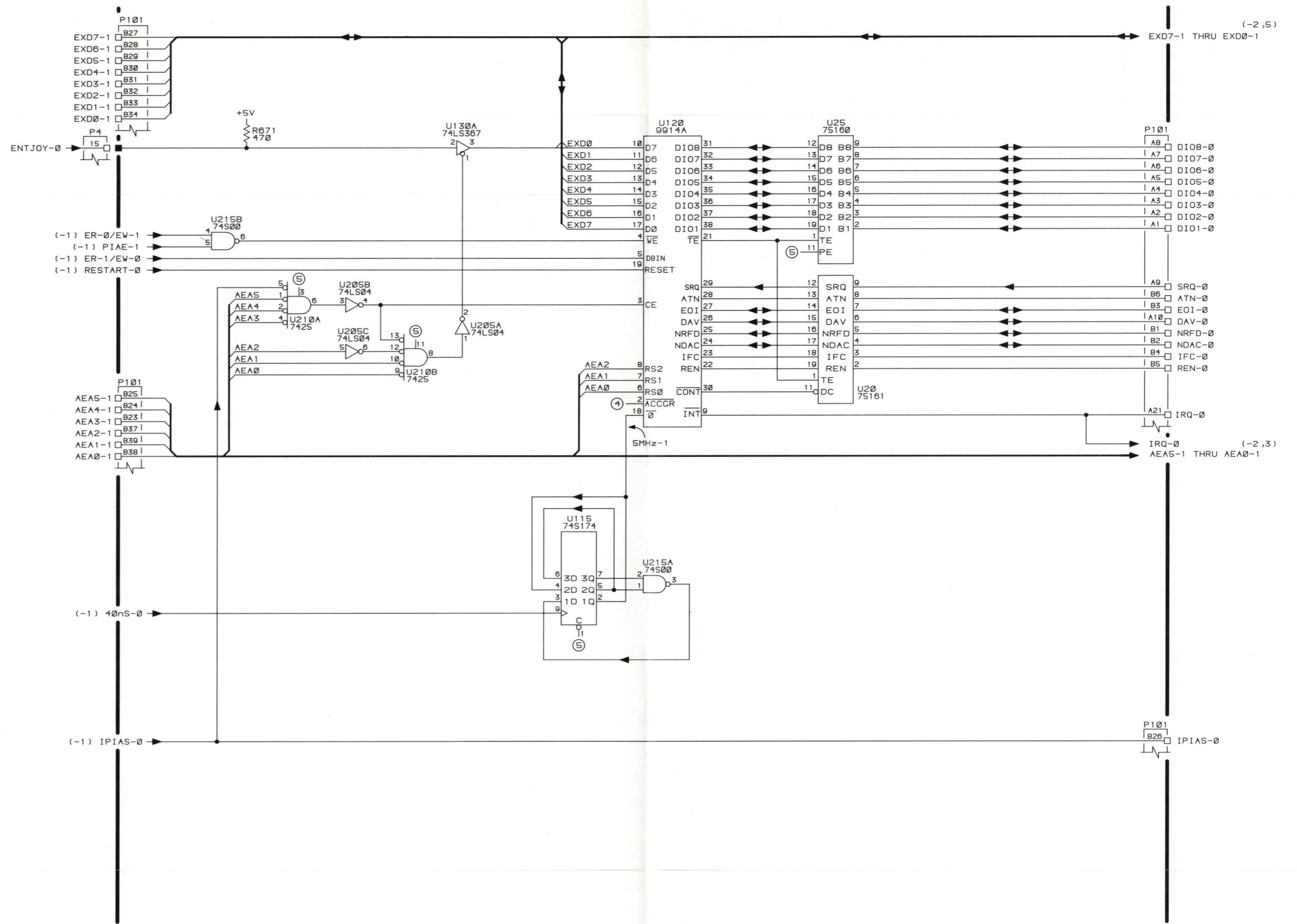

INSTRUMENT: 4052A	NOTES:	ADD, JULY 1982 2829-S34	BOARD: 670-7629-00 I/O BOARD	ASSEMBLY-SHEET: A5-5 (5 OF 6)
----------------------	--------	----------------------------	---------------------------------	-------------------------------------

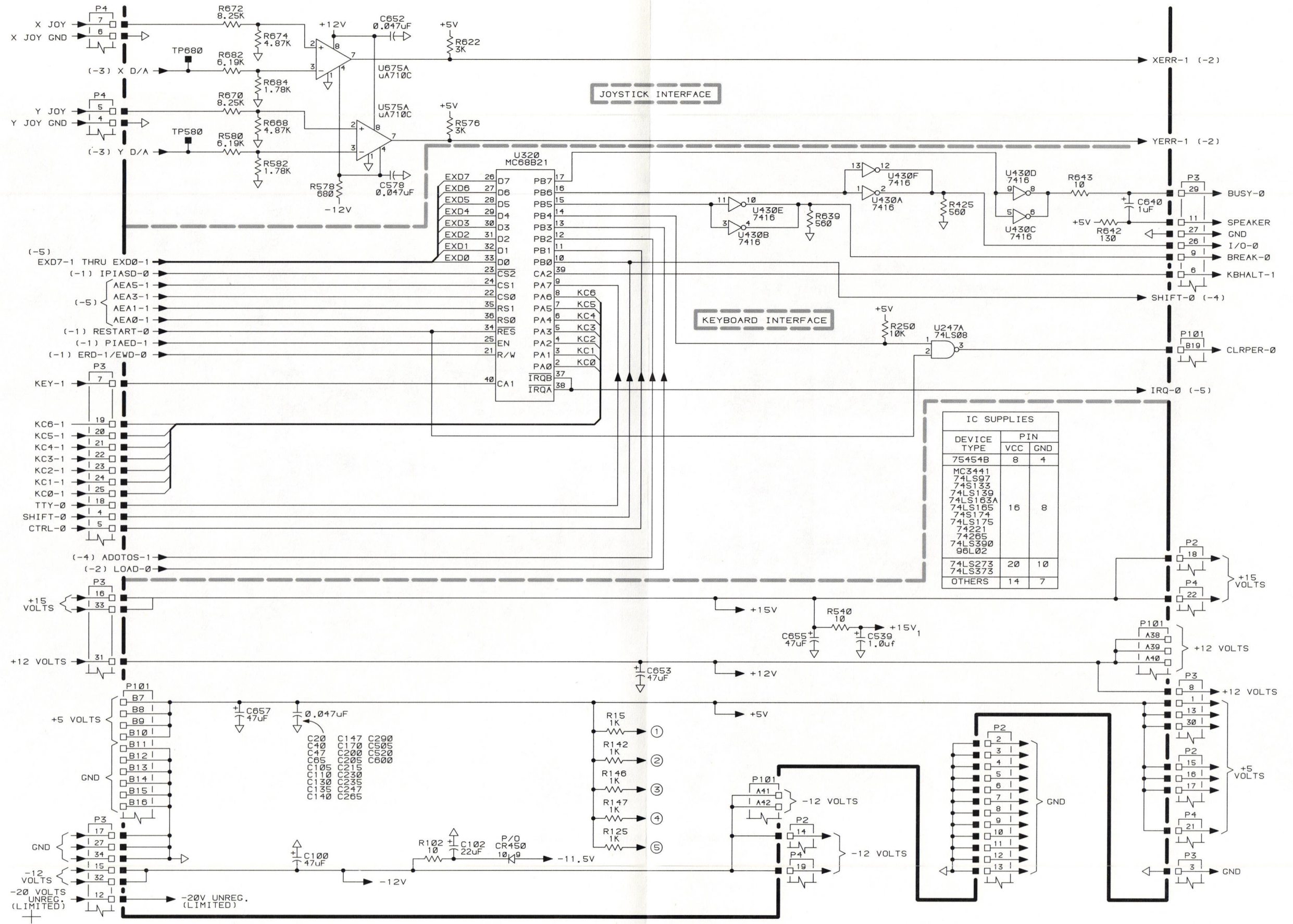

INSTRUMENT: 4052A

NOTES:

ADD, JULY 1982
2829-S35

BOARD: 670-7629-00

I/O BOARD

ASSEMBLY-SHEET: A5-6 (6 OF 6)

4052A I/O BOARD A5-6 670-7629-00

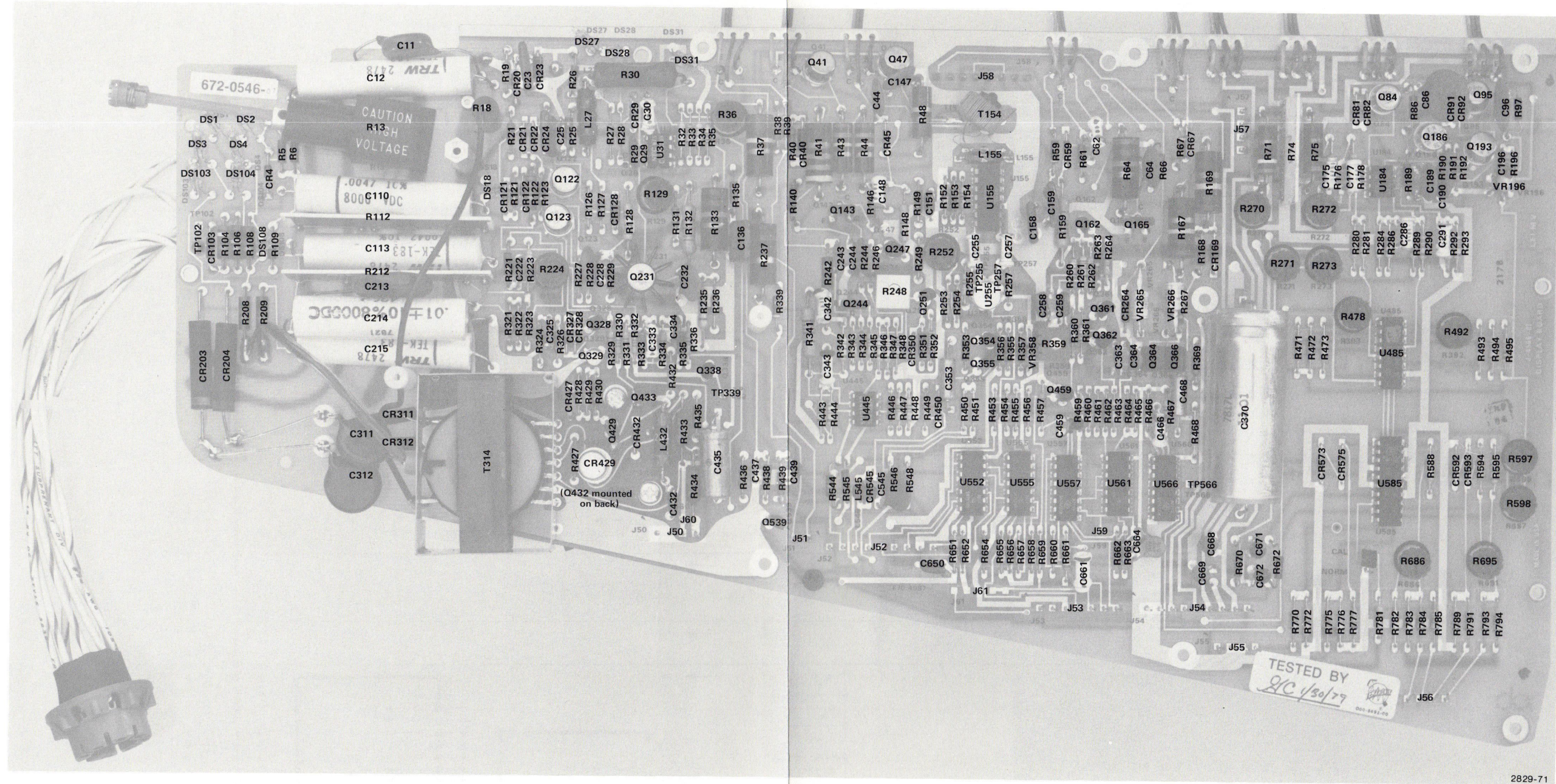

Display Board Component Locations (670-4087-05 and up).

2829-71

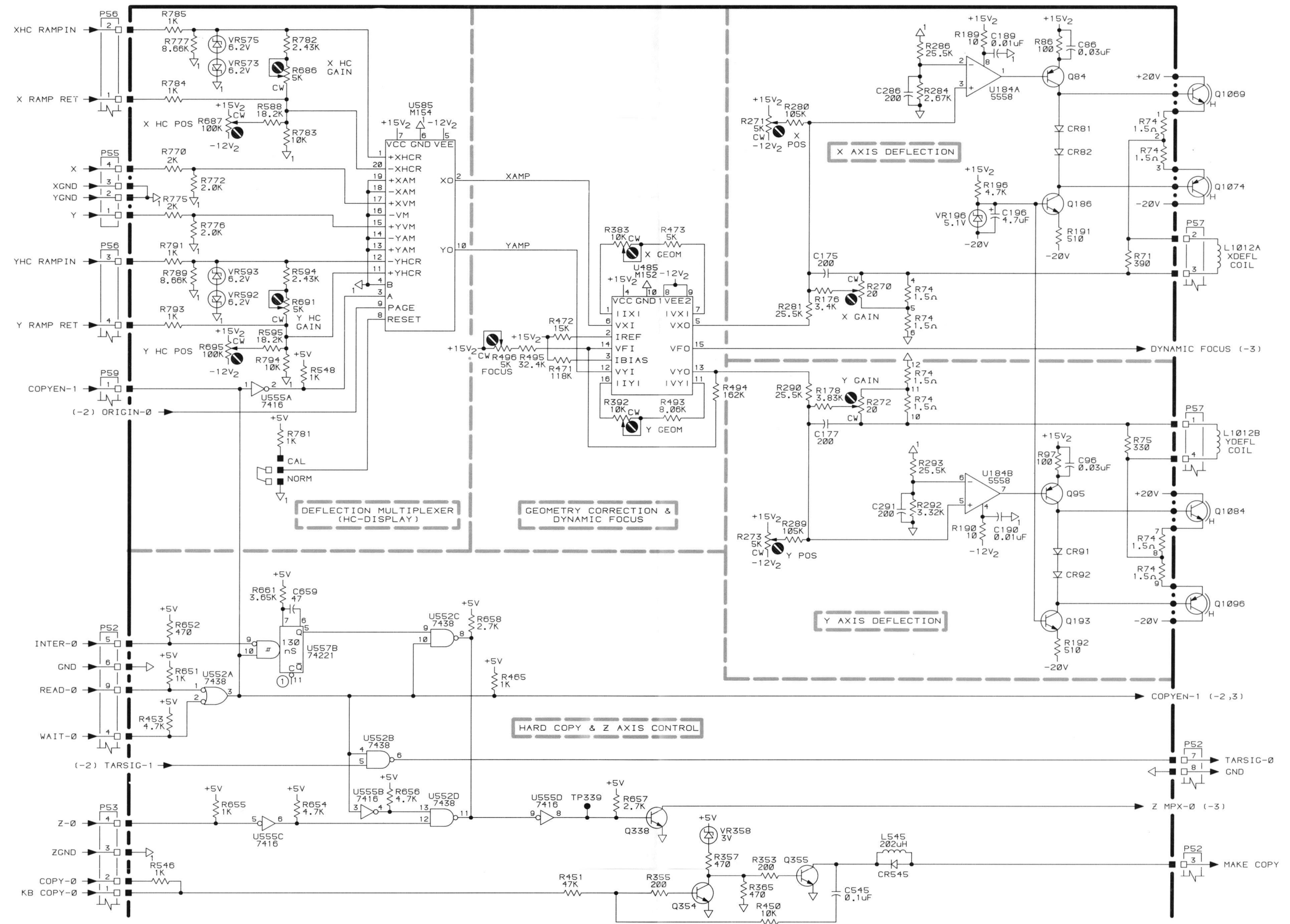

INSTRUMENT: 4052/4052A	NOTES: 	REV, JULY 1982 2829-S36	BOARD: 672-0546-08,09,10 ; 670-4087-05 & UP HARD COPY DISPLAY BOARD DEFLECTION CIRCUITRY	ASSEMBLY-SHEET: A6-1 (1 OF 4)
---------------------------	----------------	----------------------------	--	-------------------------------------

DISPLAY BOARD UP
 670-4087-05 AND UP
 A6-1

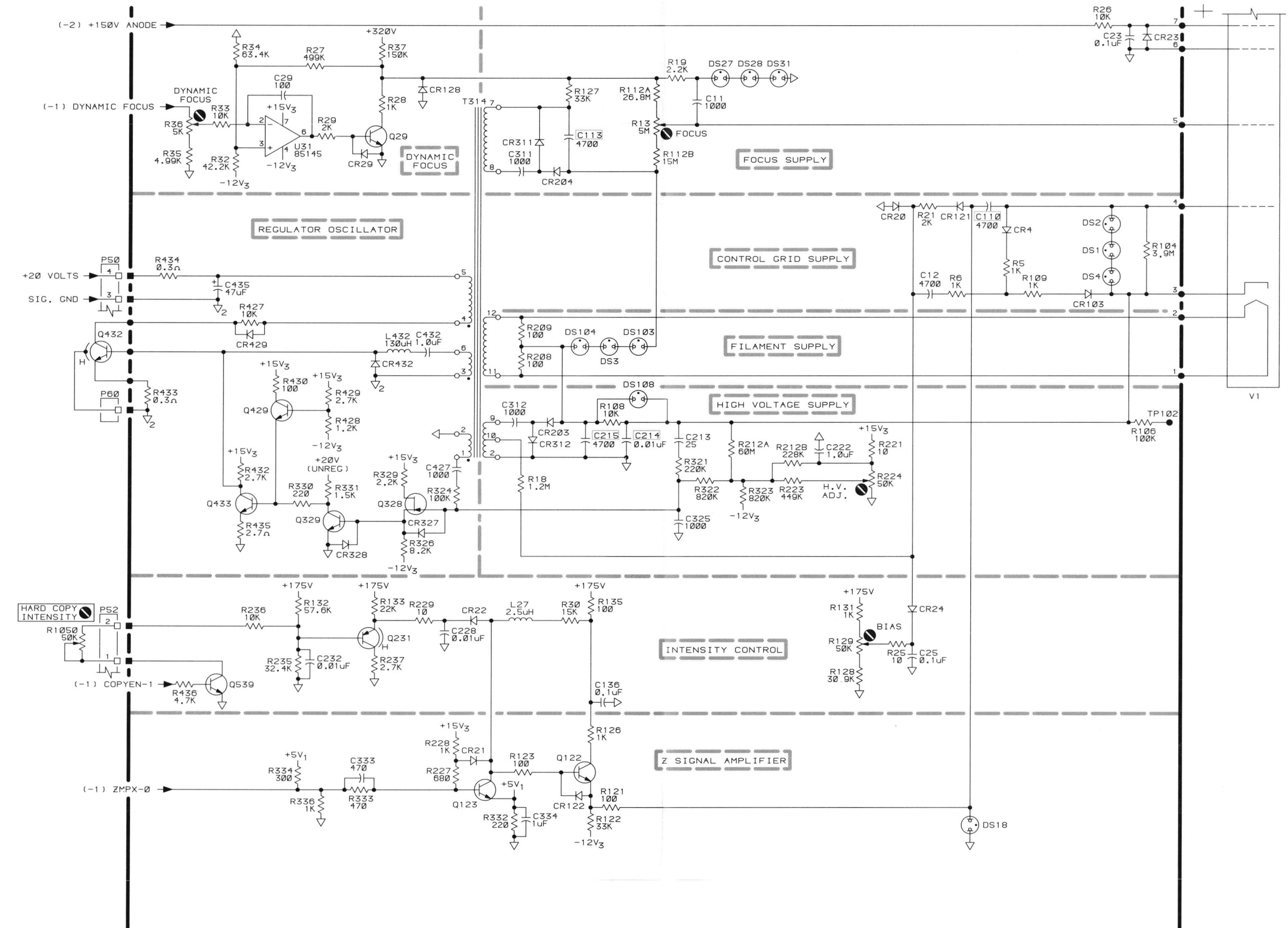

INSTRUMENT: 4052/4052A	NOTES: SEE PARTS LIST FOR EARLIER VALUES AND SERIAL NUMBER RANGES OF PARTS OUTLINED OR DEPICTED IN GREY. REV, JULY 1982 2829-538	BOARD: 672-0546-08,09,10 ; 670-4087-05 & UP HARD COPY DISPLAY BOARD HIGH VOLTAGE & Z AXIS	ASSEMBLY-SHEET: A6-3 (3 OF 4)
---------------------------	--	---	-------------------------------------

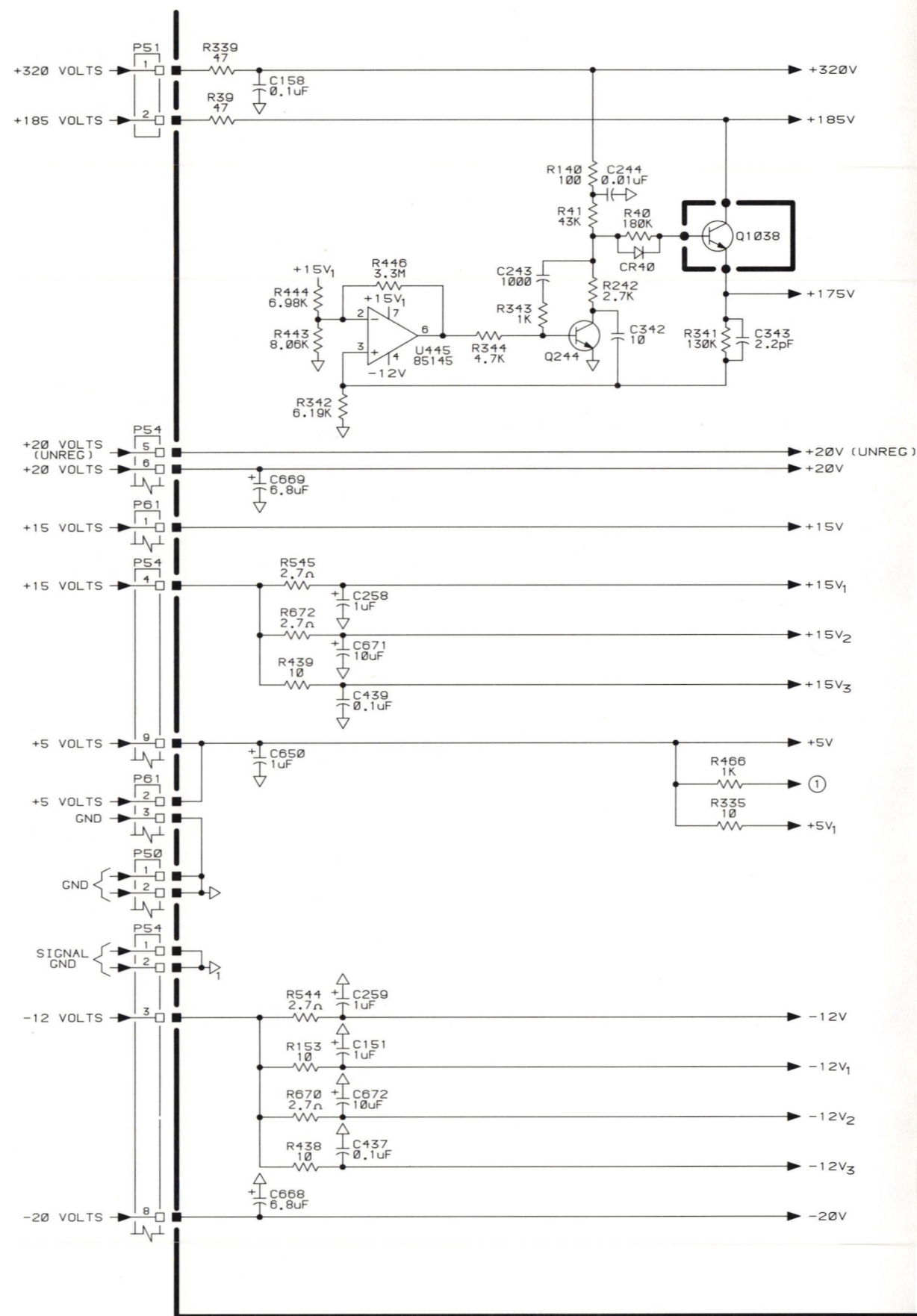

INSTRUMENT:
4052/4052A

NOTES:

REV, JULY 1982
2829-539

BOARD: 672-0546-08,09,10 ; 670-4087-05 & UP
HARD COPY DISPLAY BOARD
POWER

ASSEMBLY-SHEET:
A6-4
(4 OF 4)



2829-72

Keyboard Component Locations (670-4002-00).

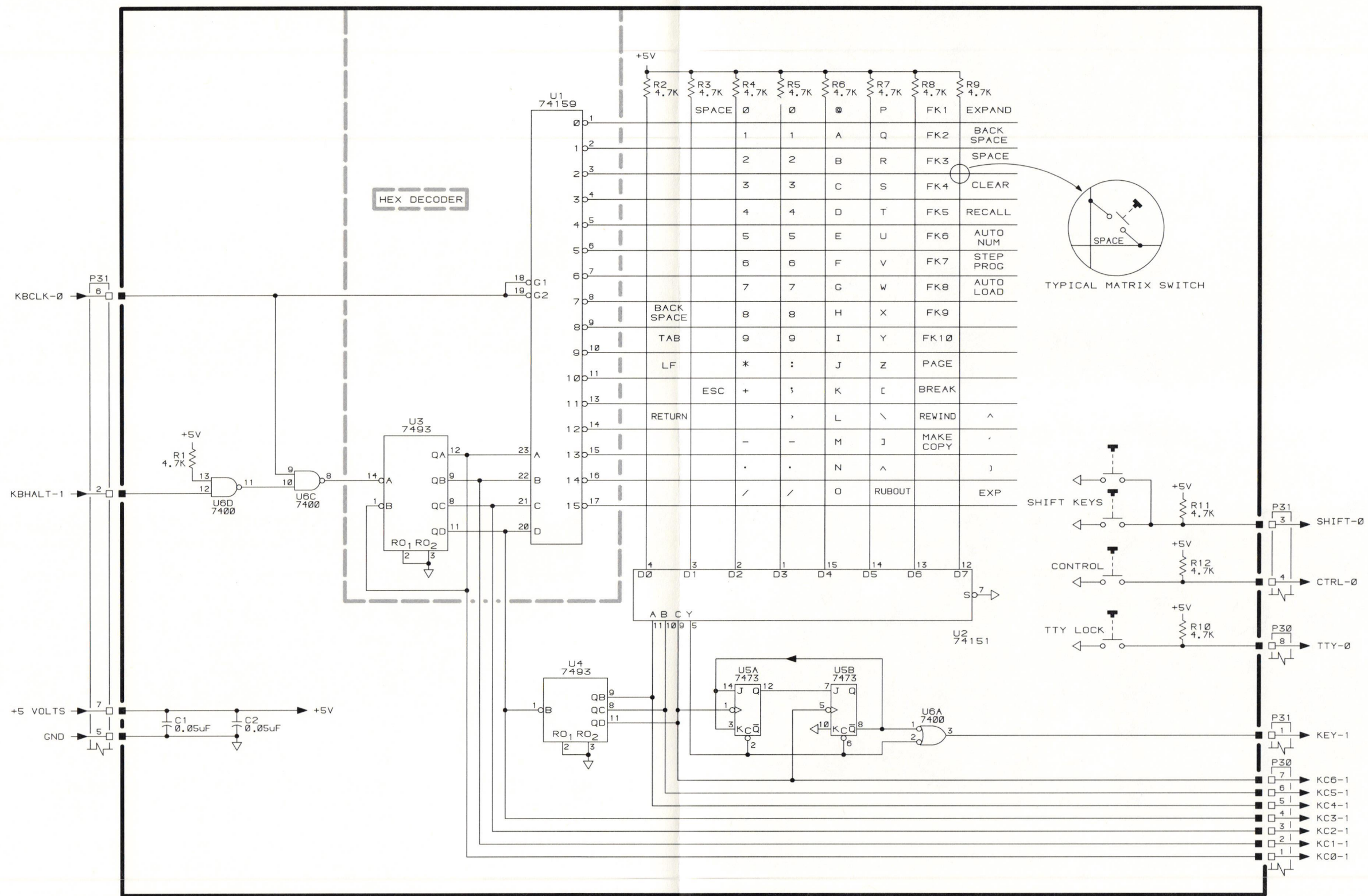

INSTRUMENT:
119-1050-00
(FOR USE WITH 4052/4052A)

NOTES:

REV, JULY 1982
CHERRY ELECTRICAL PRODUCTS CORP.
2929-S40

BOARD:

KEYBOARD

ASSEMBLY-SHEET:
A7-1
(1 OF 3)

TAPE DRIVE 670-4003-00 thru 03
COMPONENT LOCATIONS

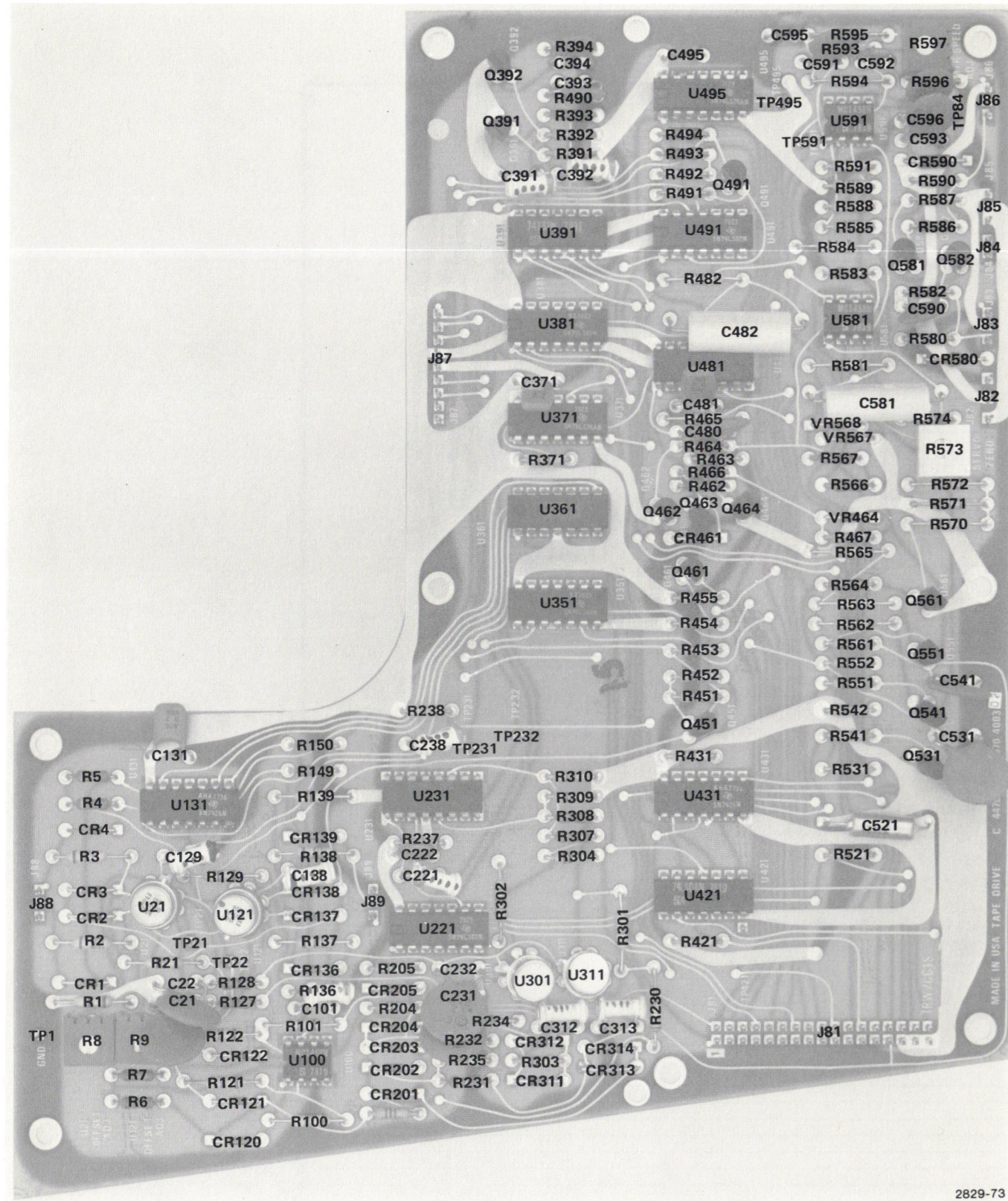

Tape Drive Board Component Locations (670-4003-00,01,02,03).

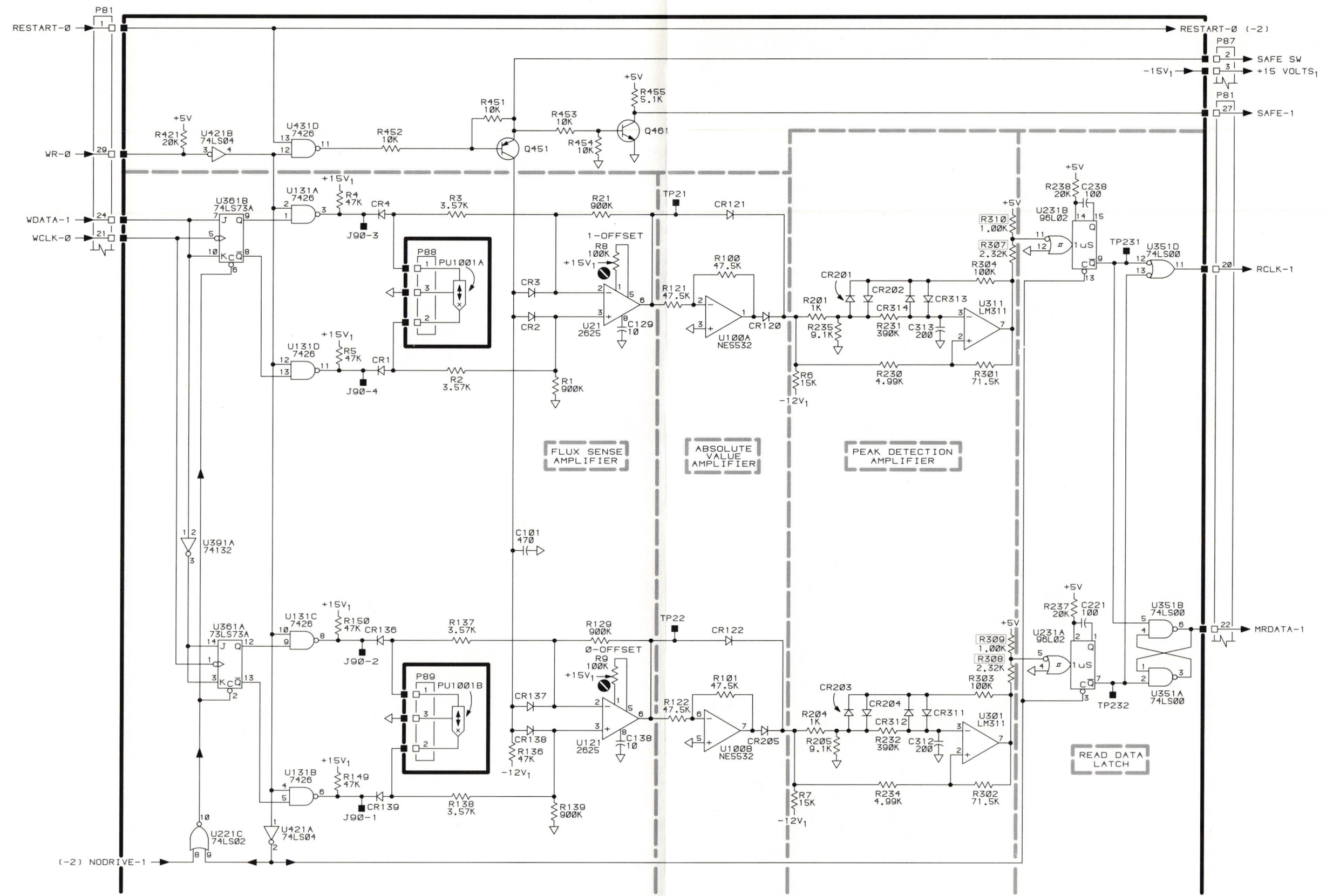

INSTRUMENT:
119-0708-01,04
(FOR USE WITH 4052/4052A)

NOTES: SEE PARTS LIST FOR EARLIER
VALUES AND SERIAL NUMBER
RANGES OF PARTS OUTLINED
OR DEPICTED IN GREY.

REV, JULY 1982
2829-S41

BOARD: 670-1003-02,03

TAPE DRIVE BOARD
HEAD AMPLIFIER

ASSEMBLY-SHEET:
A8A1-1
(1 OF 3)

TAPE DRIVE BOARD
670-1003-02,03
A8A1-1

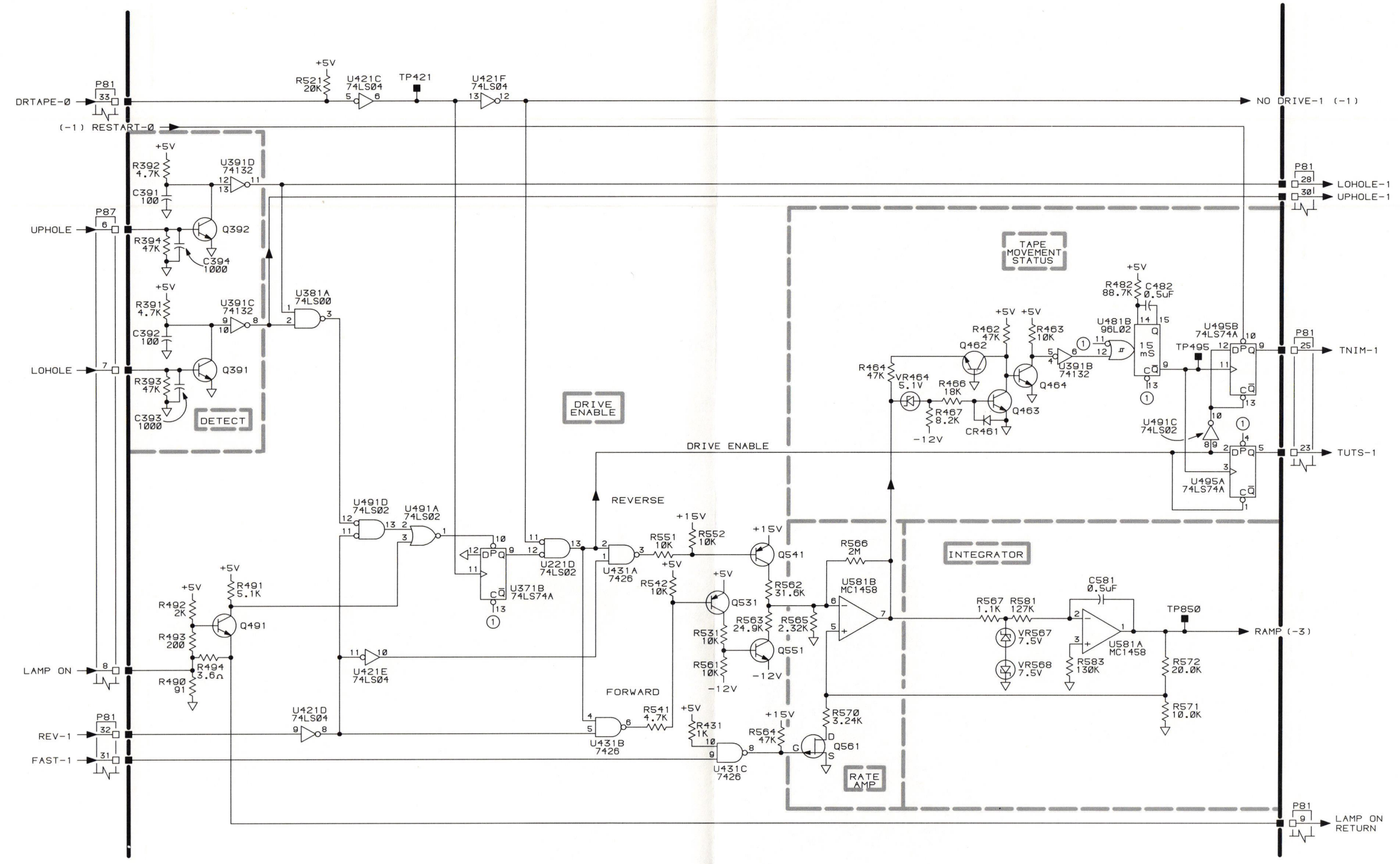

INSTRUMENT:
119-0708-01,04
(FOR USE WITH 4052/4052A)

NOTES:
REV, JULY 1982
2829-542

BOARD: 670-4003-02,03
TAPE DRIVE BOARD
MOTOR CONTROL

ASSEMBLY-SHEET:
A8A1-2
(2 OF 3)

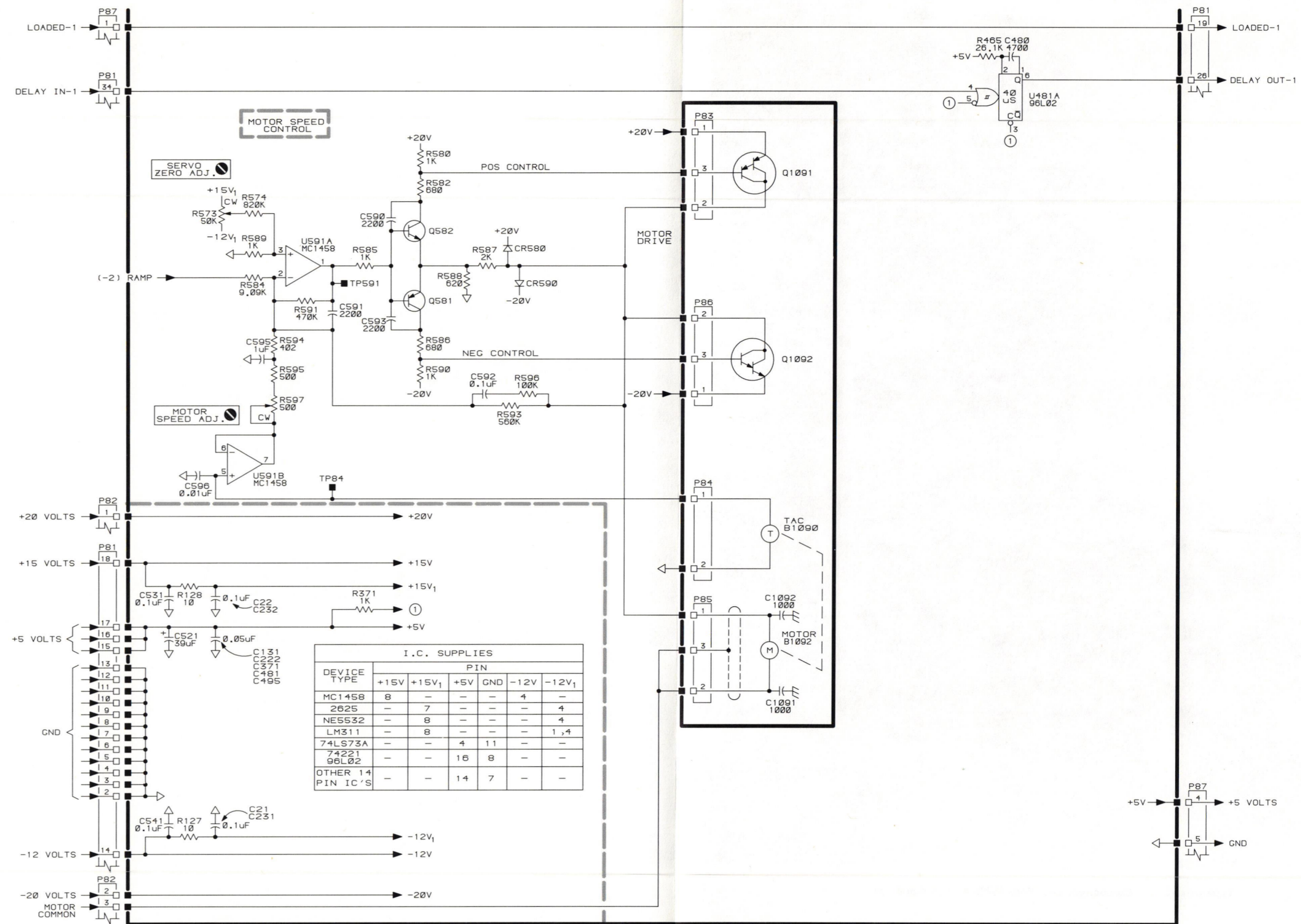

INSTRUMENT:
119-0708-01, 04
(FOR USE WITH 4052/4052A)

NOTES:
REV, JULY 1982
2829-S43

BOARD: 670-4003-02, 03
TAPPE DRIVE BOARD
MOTOR DRIVE

ASSEMBLY-SHEET:
A8A1-3
(3 OF 3)

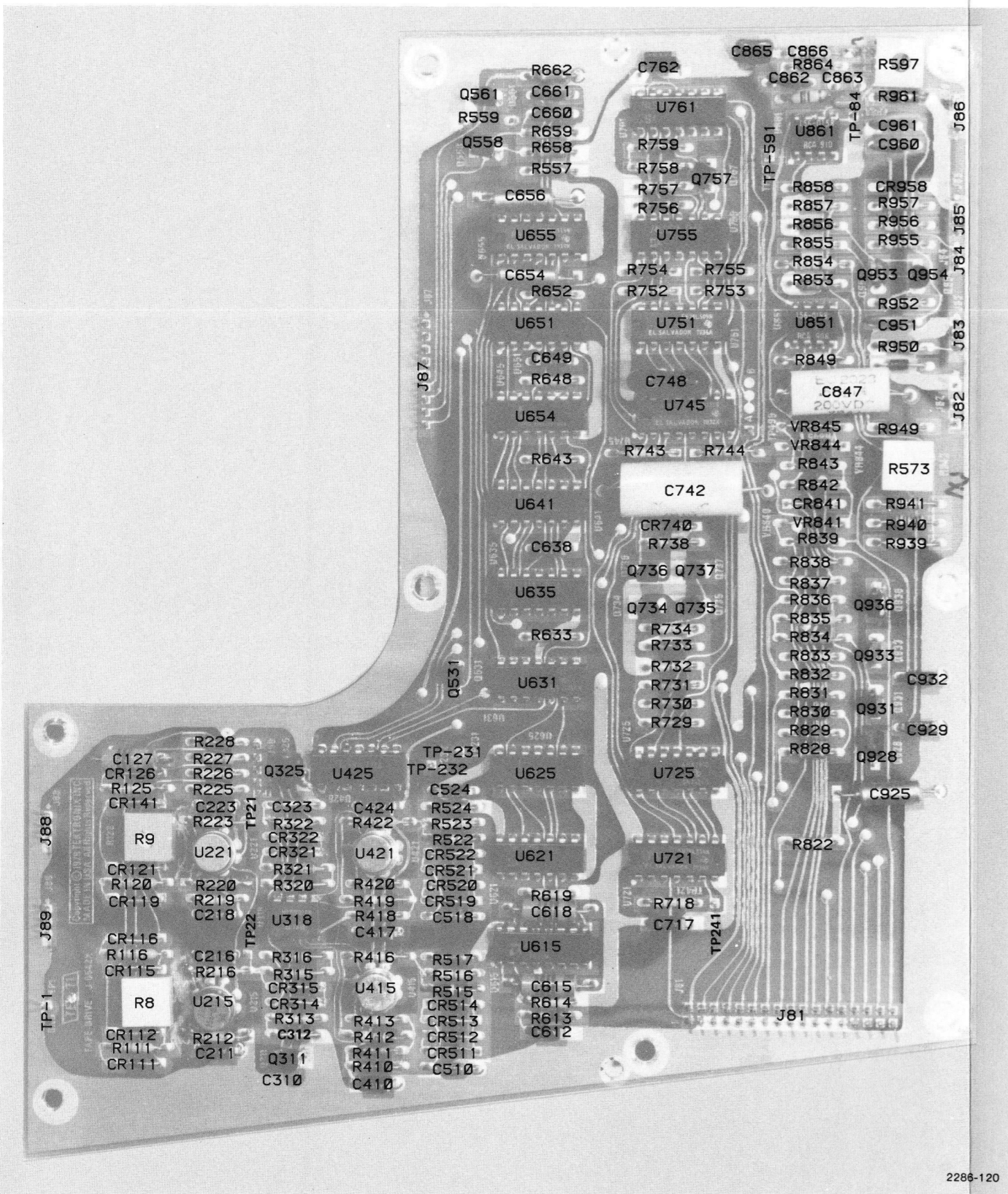

2288-120

Tape Drive Board Component Locations (670-4003-04 and up).

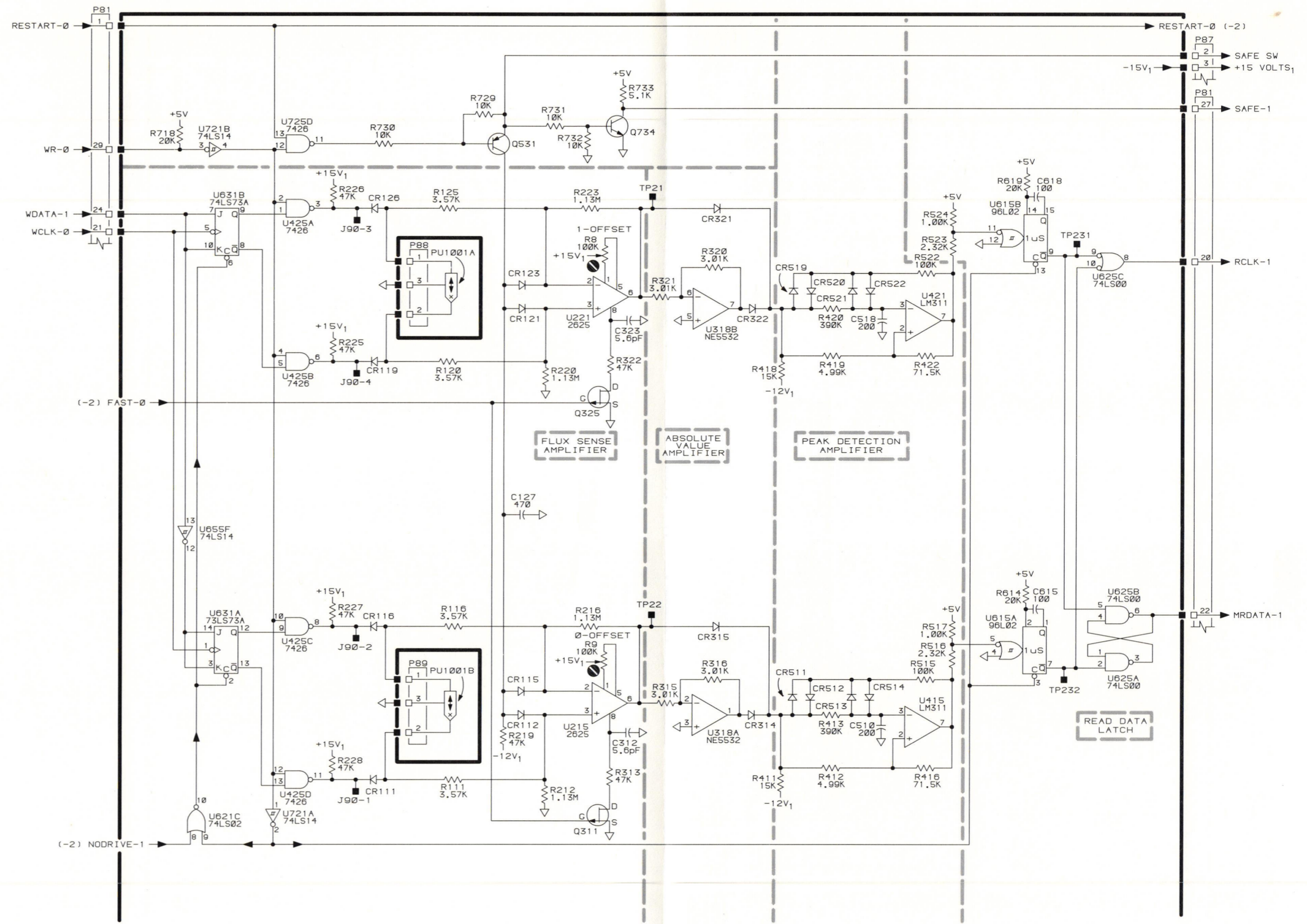

INSTRUMENT:
119-0708-05
(FOR USE WITH 4052/4052A)

NOTES:

ADD, JULY 1982
2829-544

BOARD: 670-4003-04
TAPE DRIVE BOARD
HEAD AMPLIFIER

ASSEMBLY-SHEET:
ASA1-1
(1 OF 3)

TAPE DRIVE BOARD
670-4003-04
ASA1-1

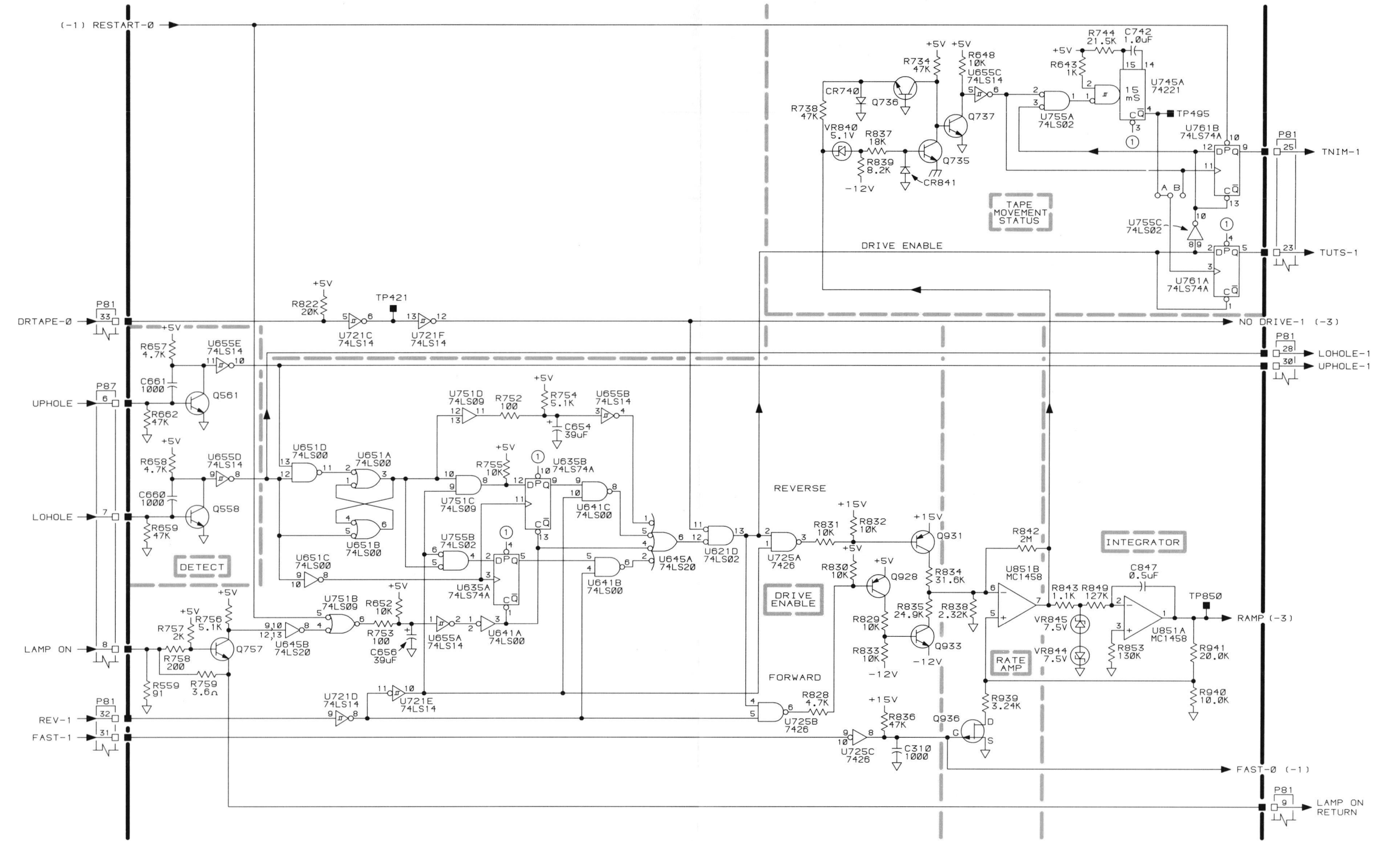

INSTRUMENT:
119-0708-05
(FOR USE WITH 4052/4052A)

NOTES:

ADD, JULY 1982
2820-545

BOARD: 670-4003-04

TAPE DRIVE BOARD
MOTOR CONTROL

ASSEMBLY-SHEET:
A8A1-2
(2 OF 3)

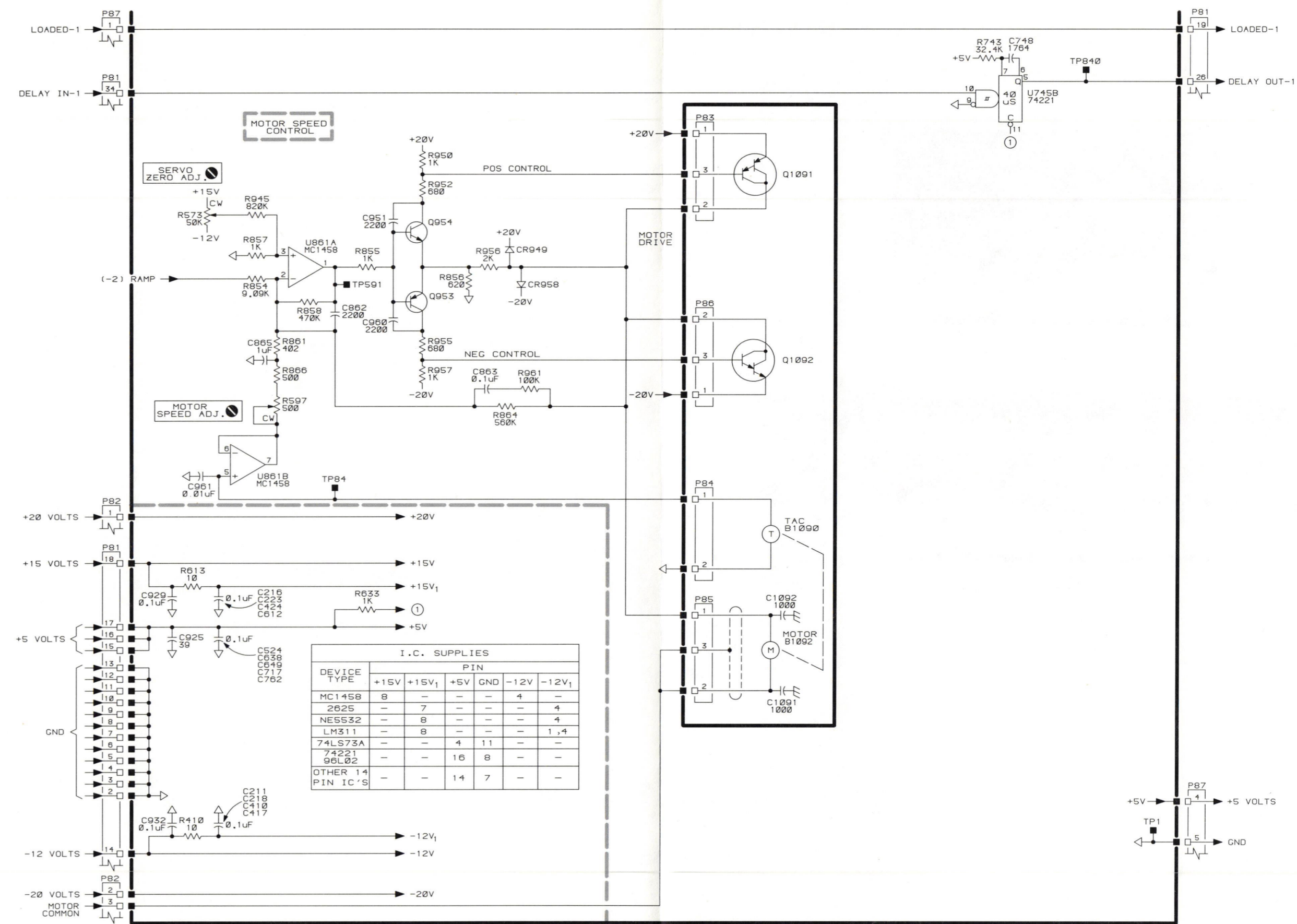

INSTRUMENT:
119-0708-05
(FOR USE WITH 4052/4052A)

NOTES:

ADD, JULY 1982
2829-546

BOARD: 670-4003-04
TAPE DRIVE BOARD
MOTOR DRIVE

ASSEMBLY-SHEET:
A8A1-3
(3 OF 3)

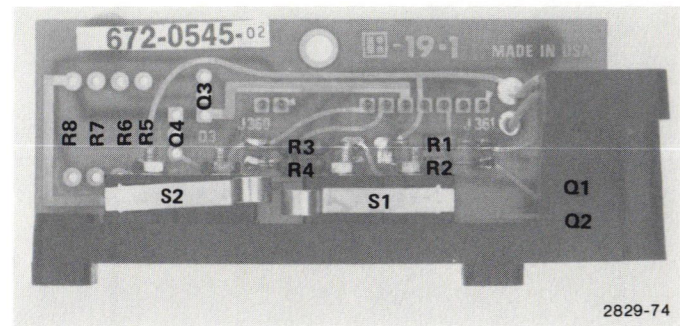

Tape Status Component Location (670-3896-00).

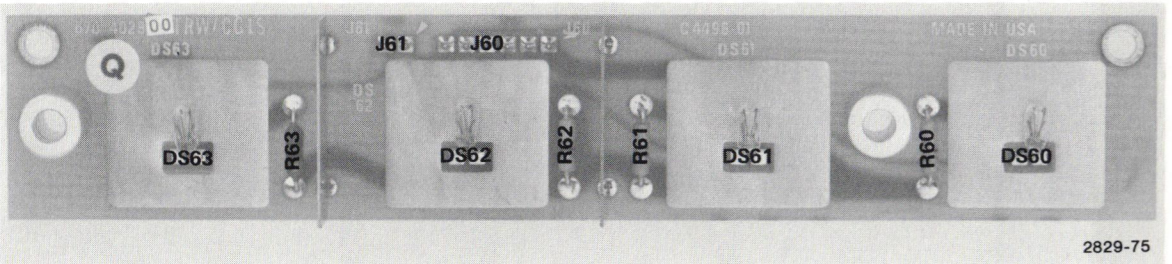

Indicator Lights Component Location (670-4029-00).

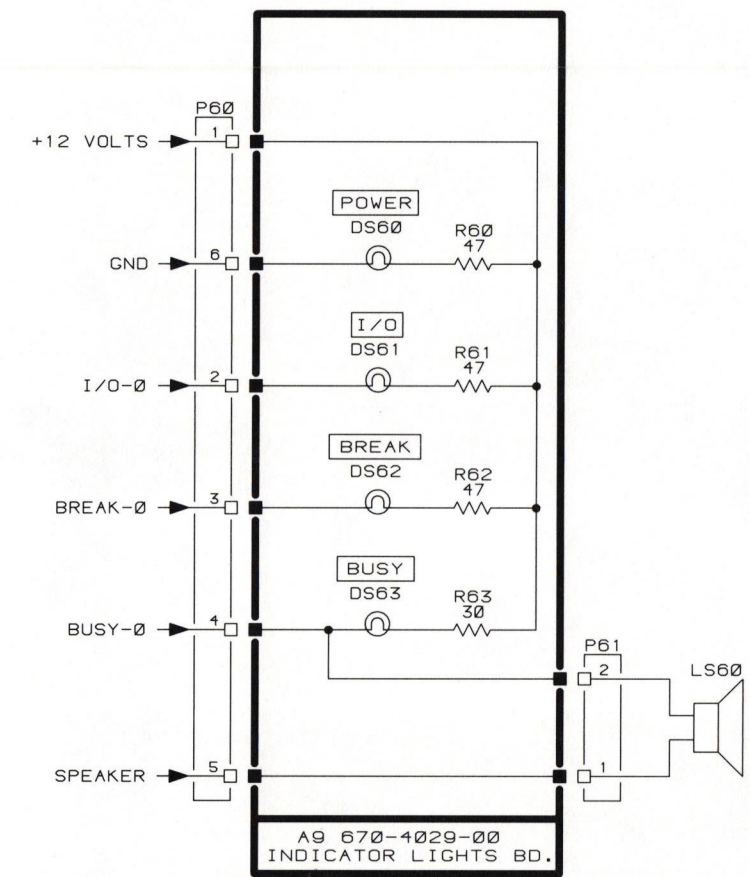
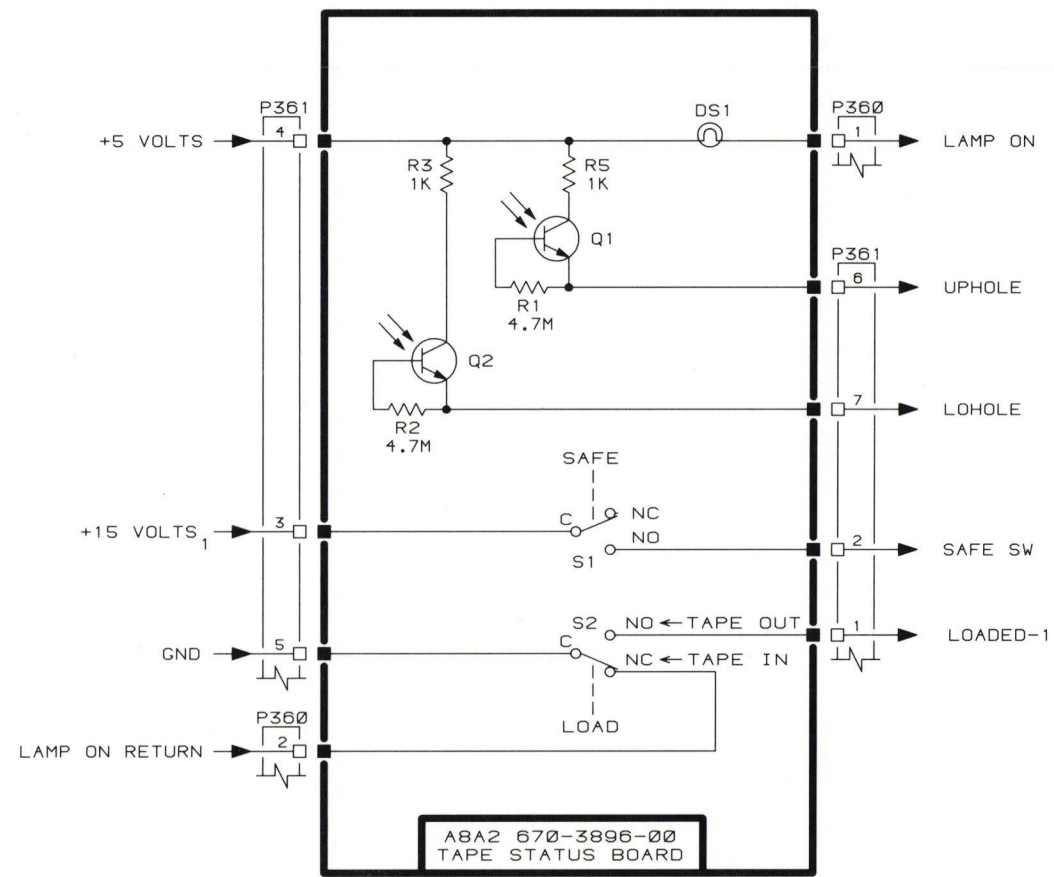

INSTRUMENT: 4052/4052A	NOTES:	REV, JULY 1982 2829-S47	BOARD: 672-0545-02 ; 670-3896-00 / 670-4029-00 TAPE STATUS BOARD INDICATOR LIGHTS BOARD	ASSEMBLY-SHEET: A8A2-1 AG-1 (1 OF 1)
---------------------------	--------	----------------------------	---	---

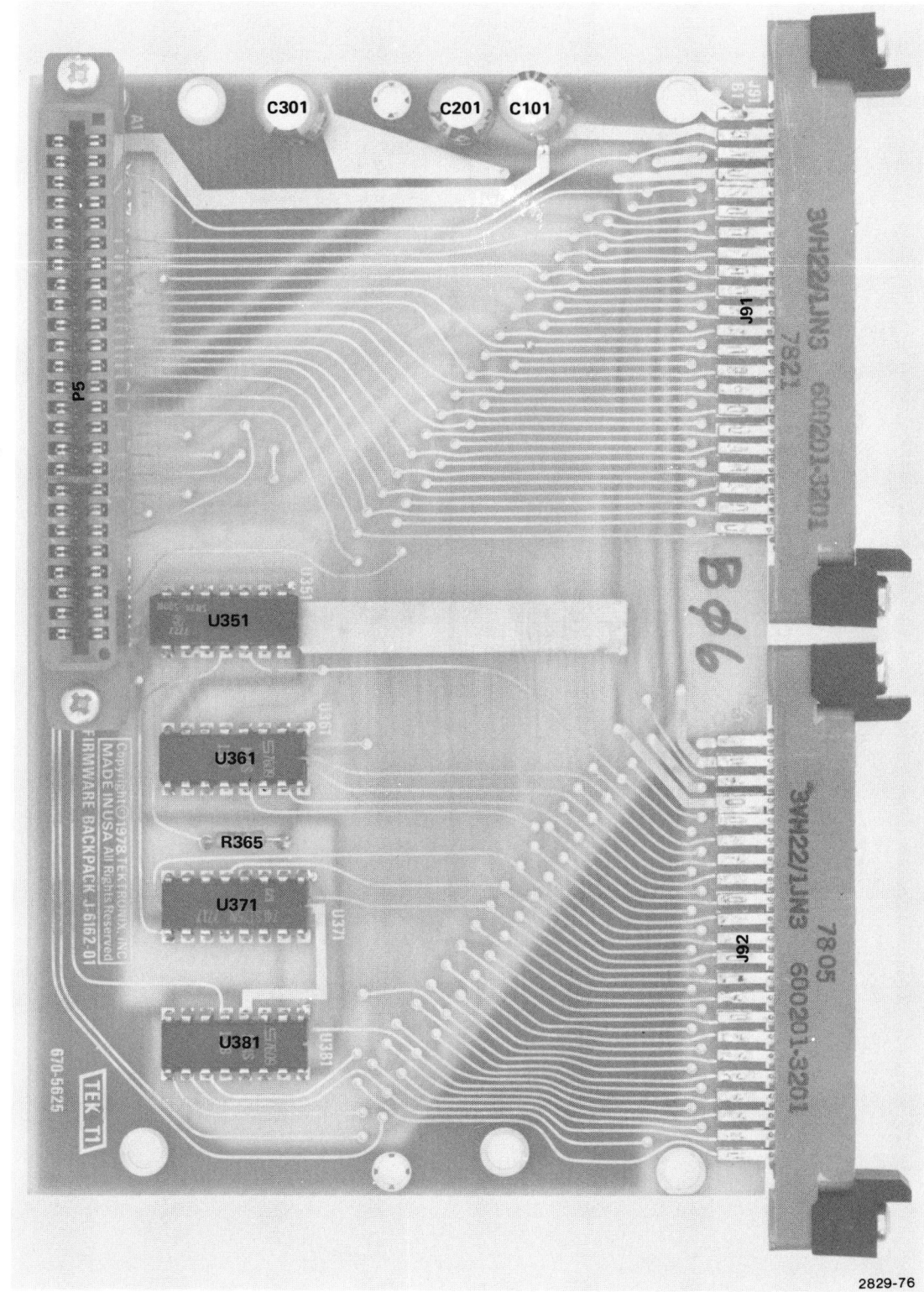

Firmware Backpack Board Component Locations (670-5625-00).

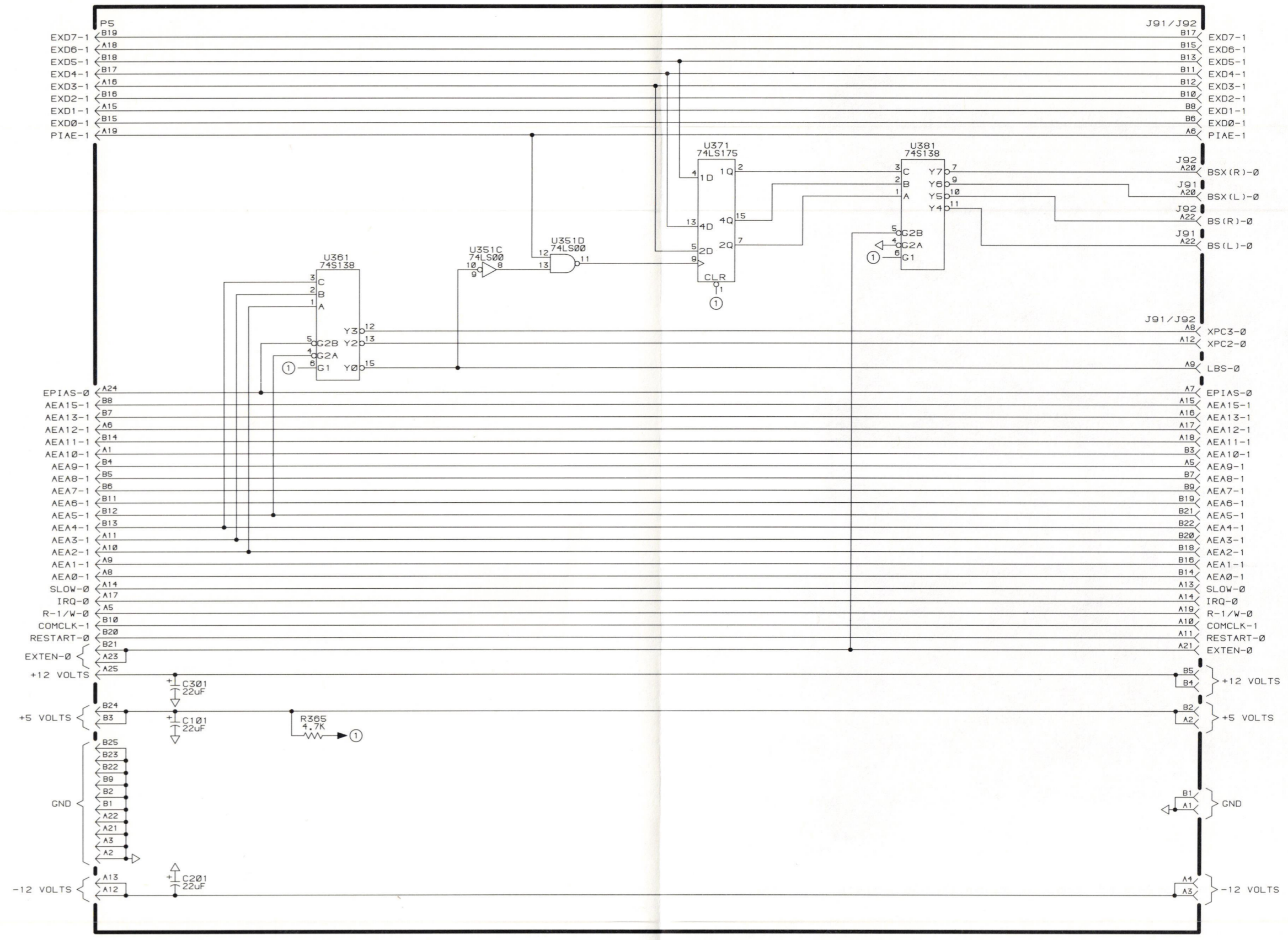

INSTRUMENT: 4052/4052A	NOTES: KEY LOCATED BETWEEN A15/B15 & A16/B16 ON J5.	REV, JULY 1982 2829-549	BOARD: 670-5625-00 FIRMWARE BACKPACK BOARD	ASSEMBLY-SHEET: A10-1 (1 OF 1)
---------------------------	---	----------------------------	---	--------------------------------------

FIRMWARE BACKPACK BRD A10-1 670-5625-00

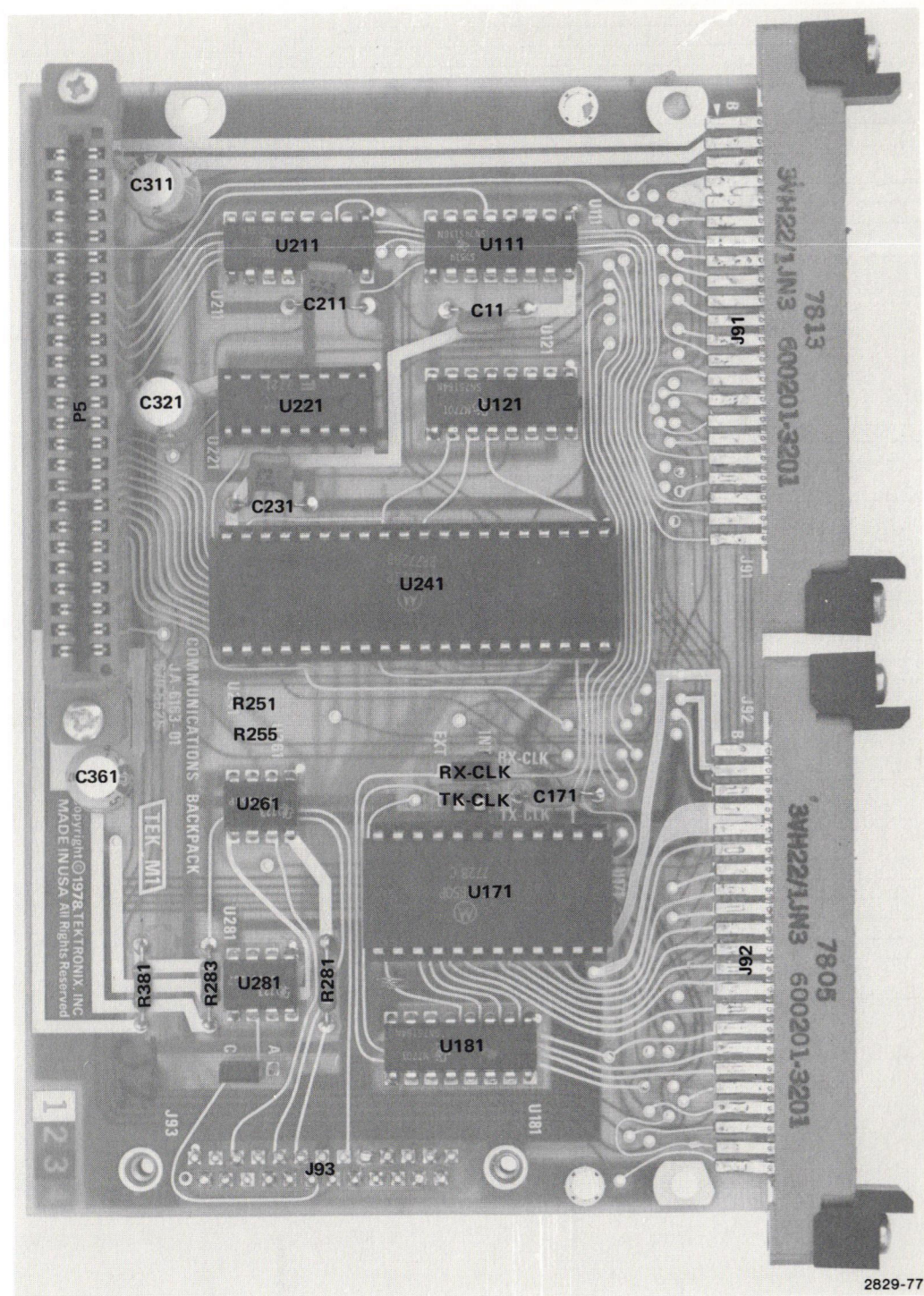

Option 01 Communication Backpack Component Locations (670-5626-00,01).

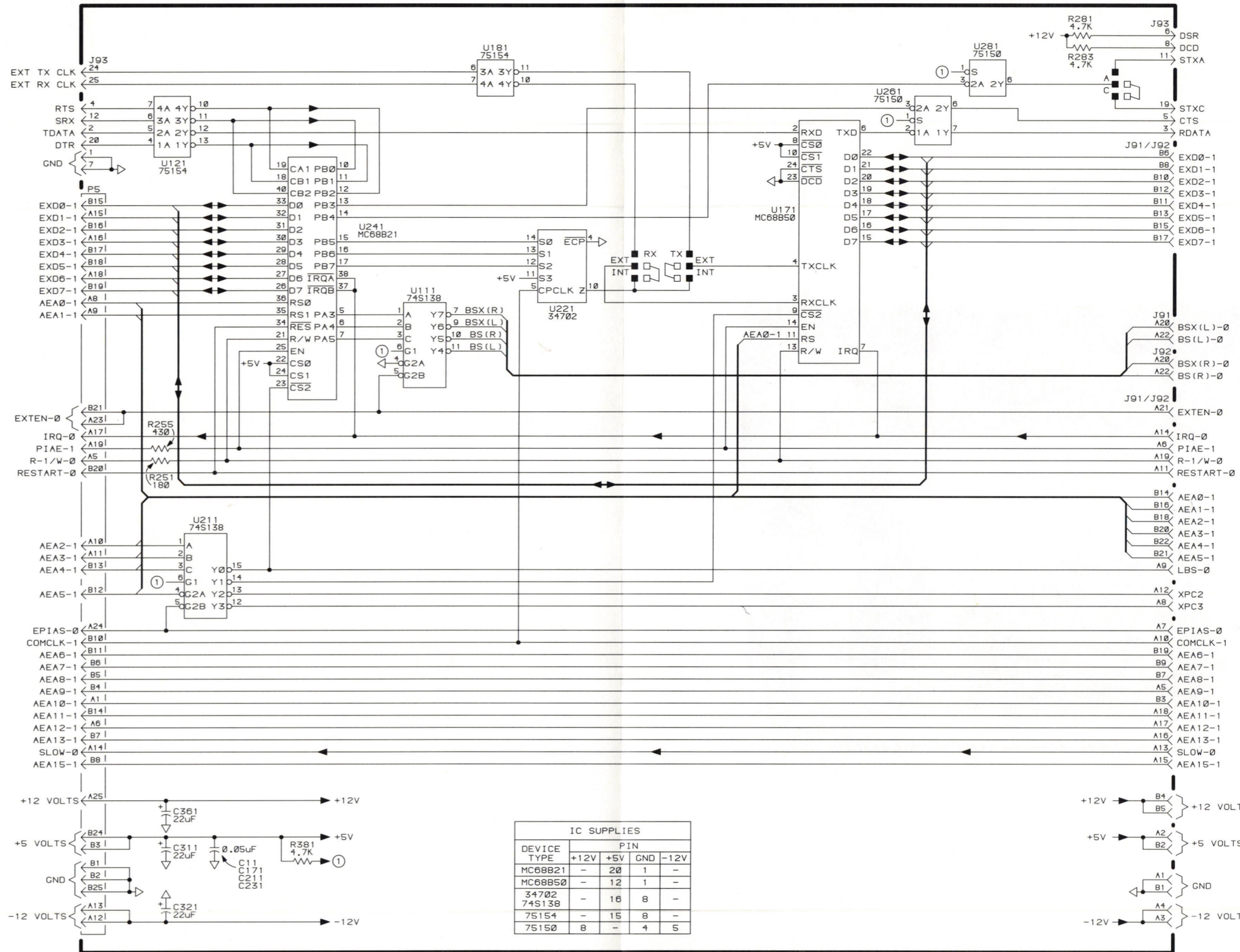

IC SUPPLIES				
DEVICE TYPE	+12V	+5V	GND	-12V
MC68821	-	20	1	-
MC68850	-	12	1	-
34702	-	16	8	-
74S138	-	15	8	-
75154	8	-	4	5

INSTRUMENT: 4052/4052A OPT. 1

NOTES: KEY LOCATED BETWEEN A15/B15 & A16/B16 ON J5

REV, JULY 1982
2829-550

BOARD: 670-5626-00,01

COMMUNICATION BACKPACK

ASSEMBLY-SHEET: A11-1 (1 OF 1)

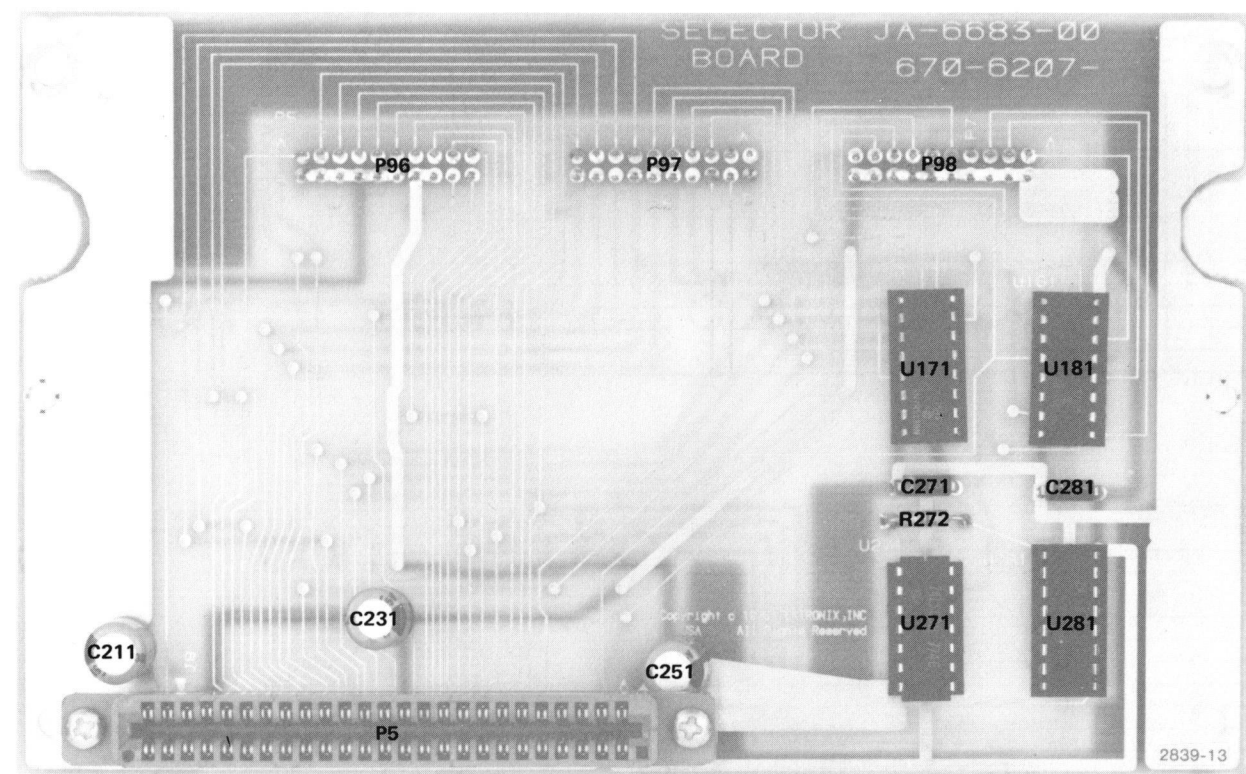

Option 02 Selector Board Component Locations (670-6207-00).

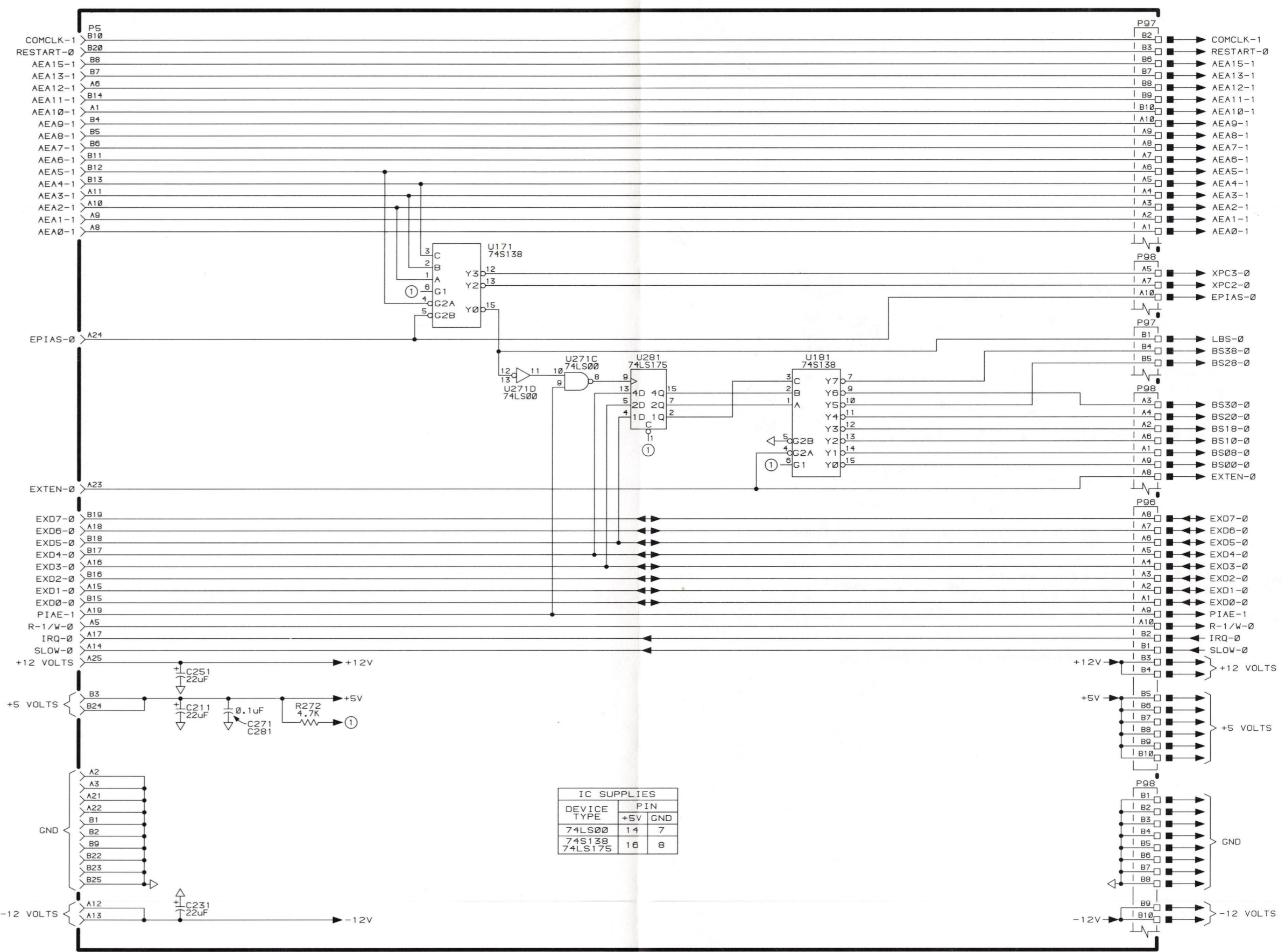

IC SUPPLIES		
DEVICE TYPE	+5V	PIN
74LS00	14	7
74LS138	16	8
74LS175		

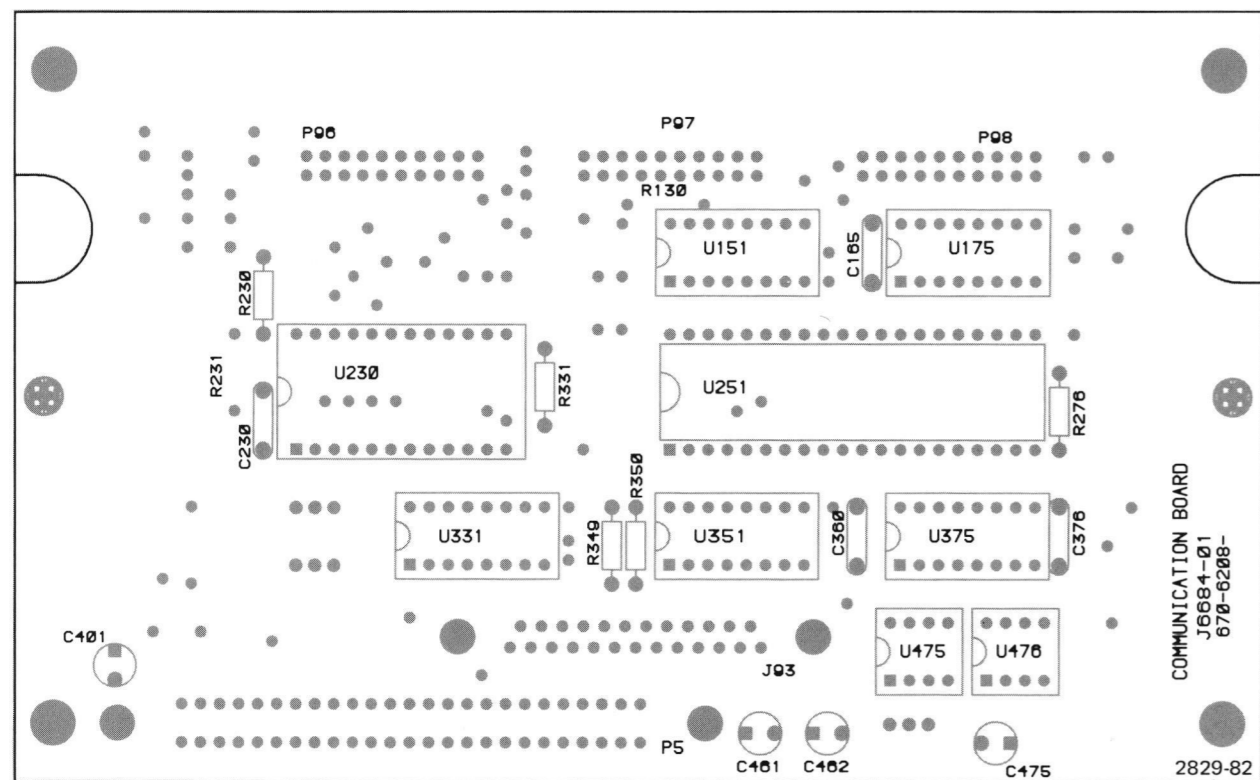

Option 03 Communication Board Component Locations (670-6208-00).

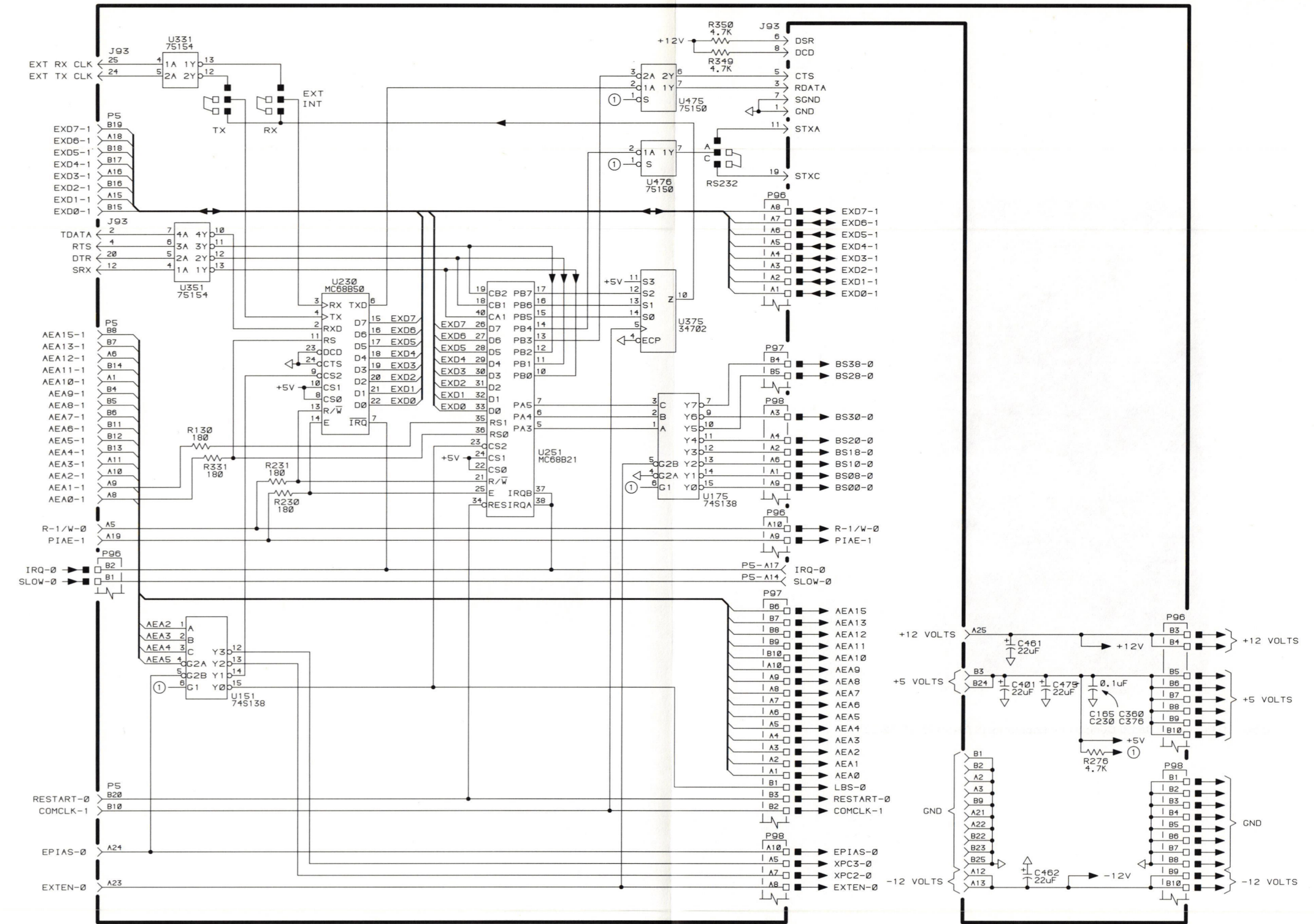

INSTRUMENT: 4052/4052A OPT. 3	NOTES: KEY LOCATED BETWEEN A15/B15 & A16/B16 OF P5.	REV, JULY 1982 2829-552	BOARD: 670-6208-00 COMMUNICATION BOARD	ASSEMBLY-SHEET: A13-1 (1 OF 1)
-------------------------------------	---	----------------------------	---	--------------------------------------

OPT. 03 COMM. BOARD
670-6208-00
A13-1

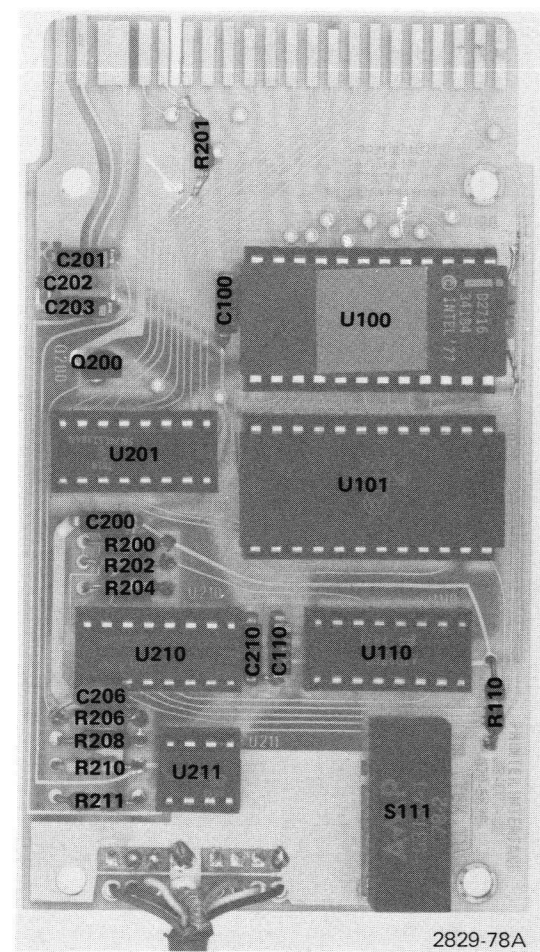

Option 10 Printer I/F Board Component Locations (670-5636-00,02,03).

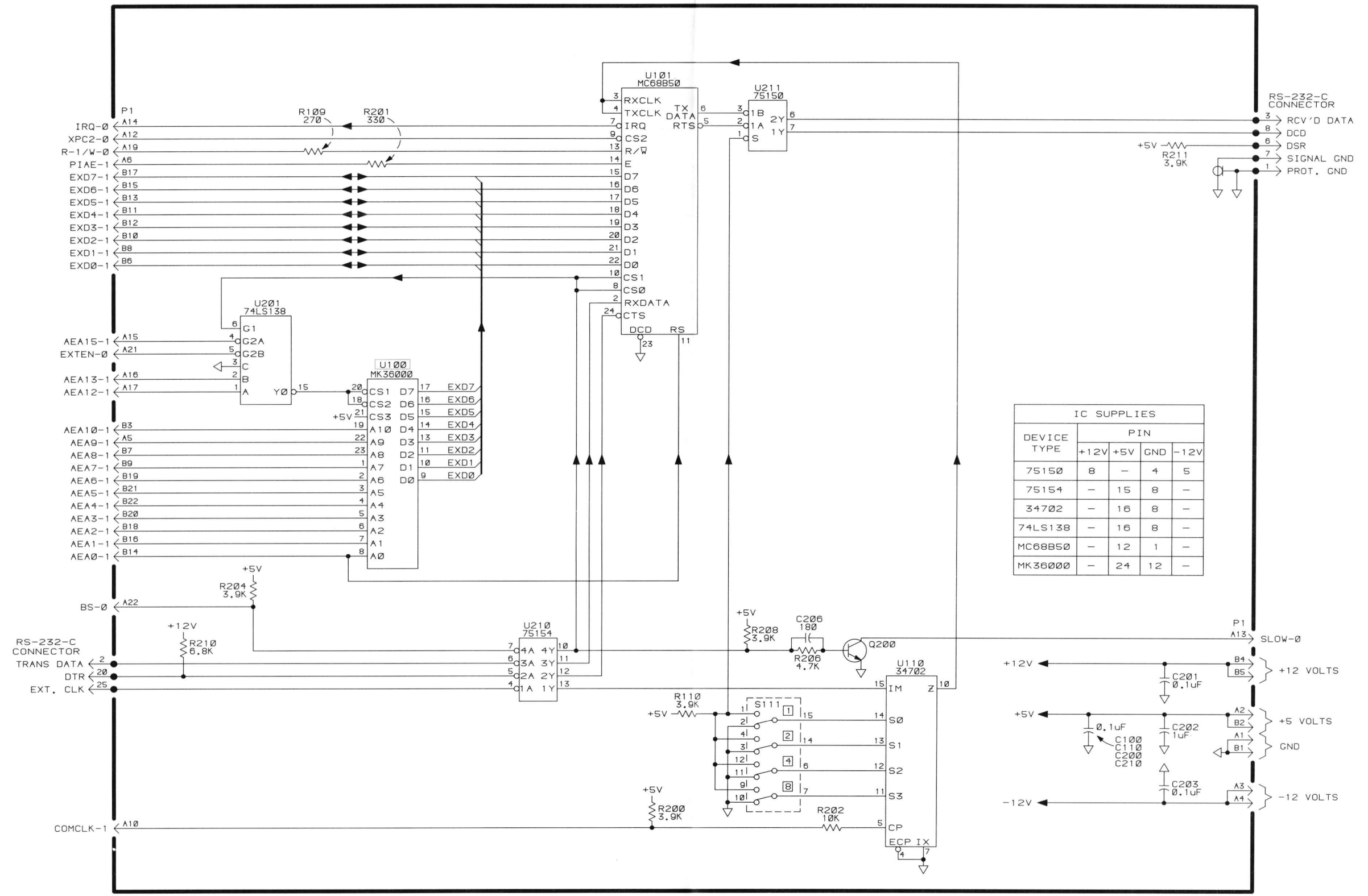

IC SUPPLIES				
DEVICE TYPE	PIN			
	+12V	+5V	GND	-12V
75150	8	-	4	5
75154	-	15	8	-
34702	-	16	8	-
74LS138	-	16	8	-
MC68850	-	12	1	-
MK36000	-	24	12	-

INSTRUMENT:
4052/4052A
OPT. 10

NOTES: SEE PARTS LIST FOR EARLIER VALUES AND SERIAL NUMBER RANGES OF PARTS OUTLINED OR DEPICTED IN GREY.

REV, JULY 1982
2829-SS3

BOARD: 670-5636-00,02,03
PRINTER INTERFACE BOARD

ASSEMBLY-SHEET:
A14-1
(1 OF 1)

OPT. 10 PRINTER I/F
670-5636-00,02,03
A14-1

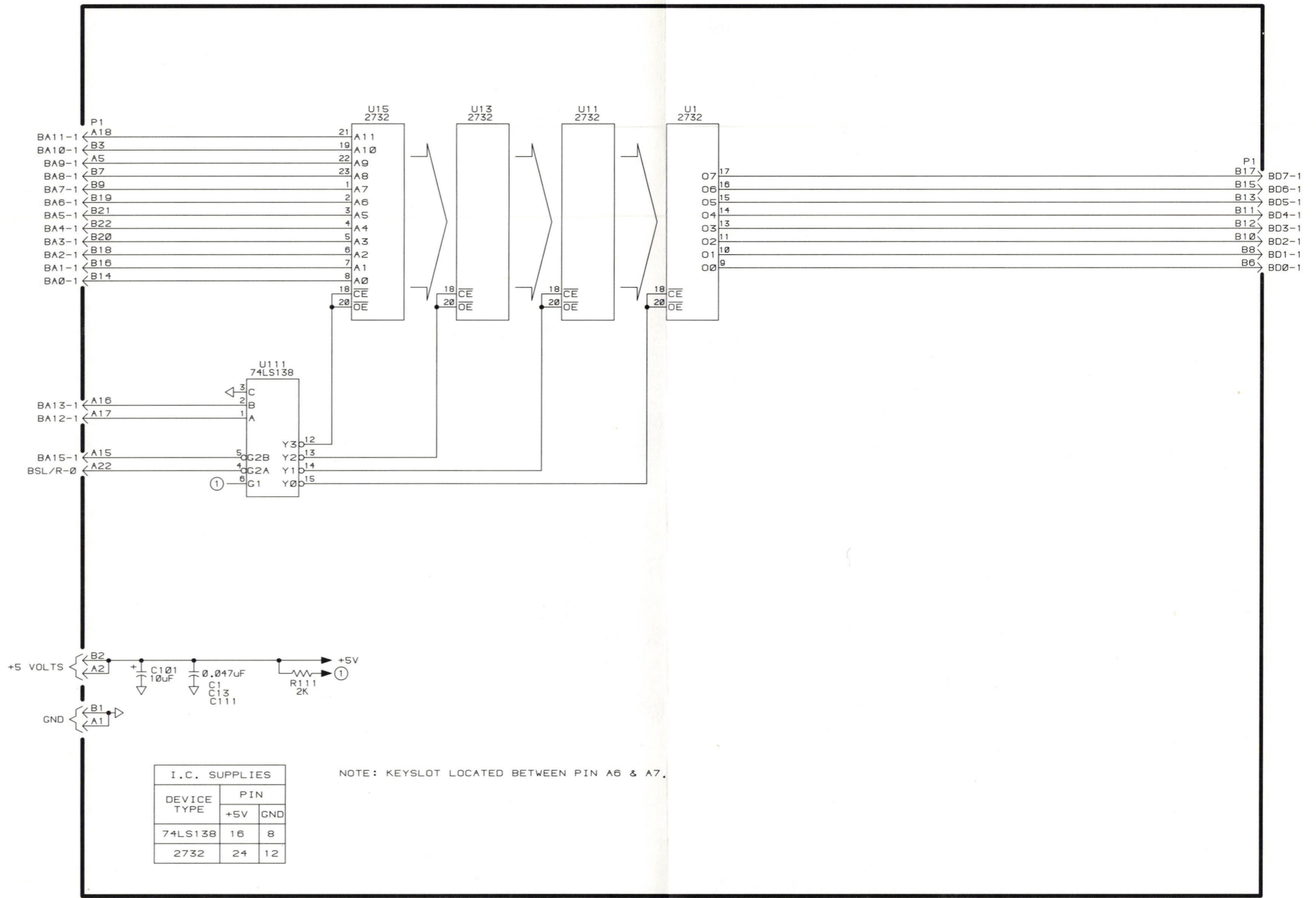

I.C. SUPPLIES		
DEVICE TYPE	PIN	
	+5V	GND
74LS138	16	8
2732	24	12

NOTE: KEYSLOT LOCATED BETWEEN PIN A6 & A7.

INSTRUMENT: 4052/4052A R06	NOTES:	REV, JULY 1982 2829-554	BOARD: 670-7485-00 16K ROM PACK	ASSEMBLY-SHEET: A15-1 (1 OF 1)
----------------------------------	--------	----------------------------	------------------------------------	--------------------------------------

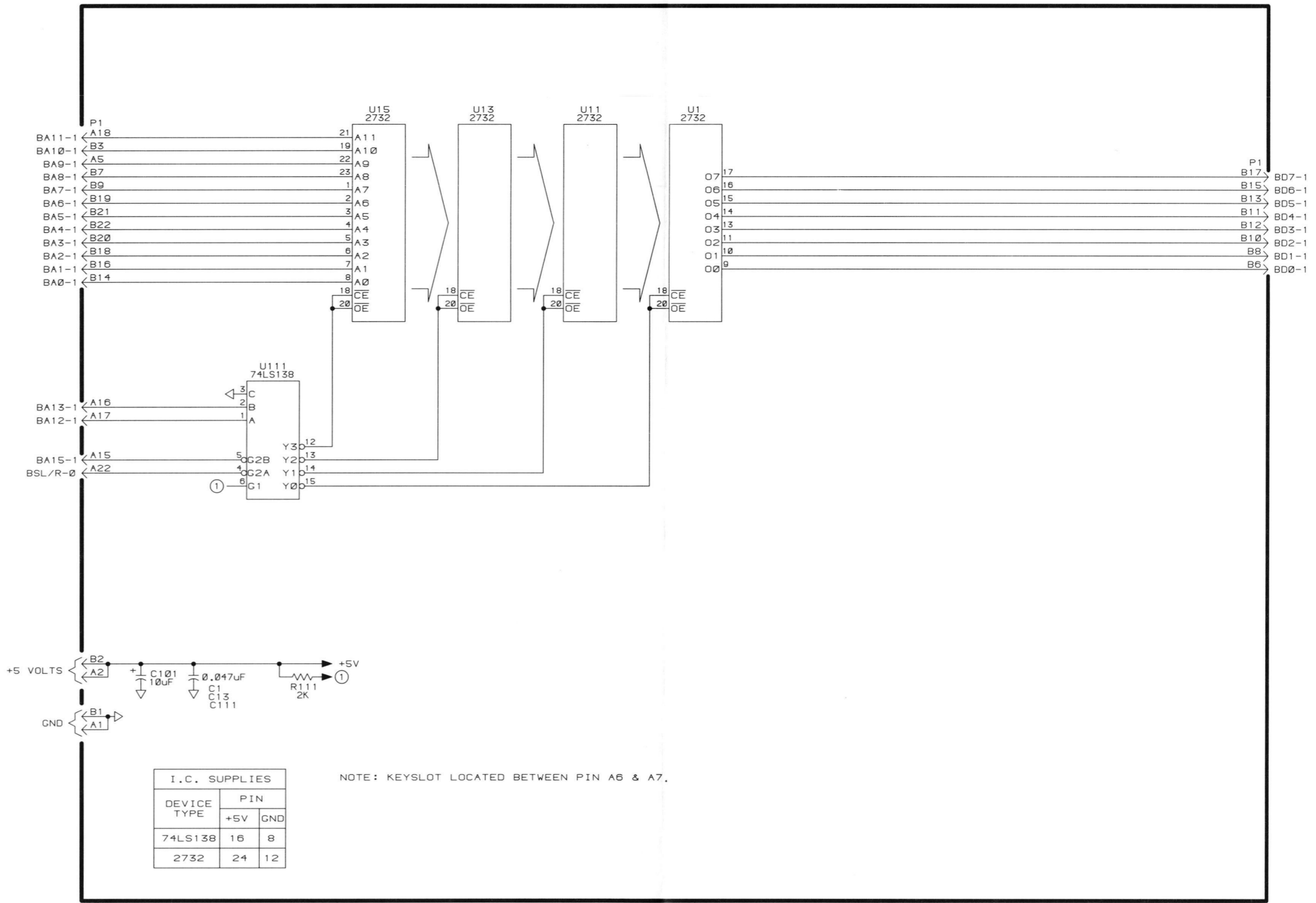

I.C. SUPPLIES		
DEVICE TYPE	PIN	
	+5V	GND
74LS138	16	8
2732	24	12

NOTE: KEYSLOT LOCATED BETWEEN PIN A6 & A7.

INSTRUMENT: 4052/4052A R07	NOTES:	REV, JULY 1982 2829-555	BOARD: 670-7486-00 16K ROM PACK SIGNAL PROCESSING ROM PACK NO.1	ASSEMBLY-SHEET: A16-1 (1 OF 1)
----------------------------------	--------	----------------------------	--	--------------------------------------

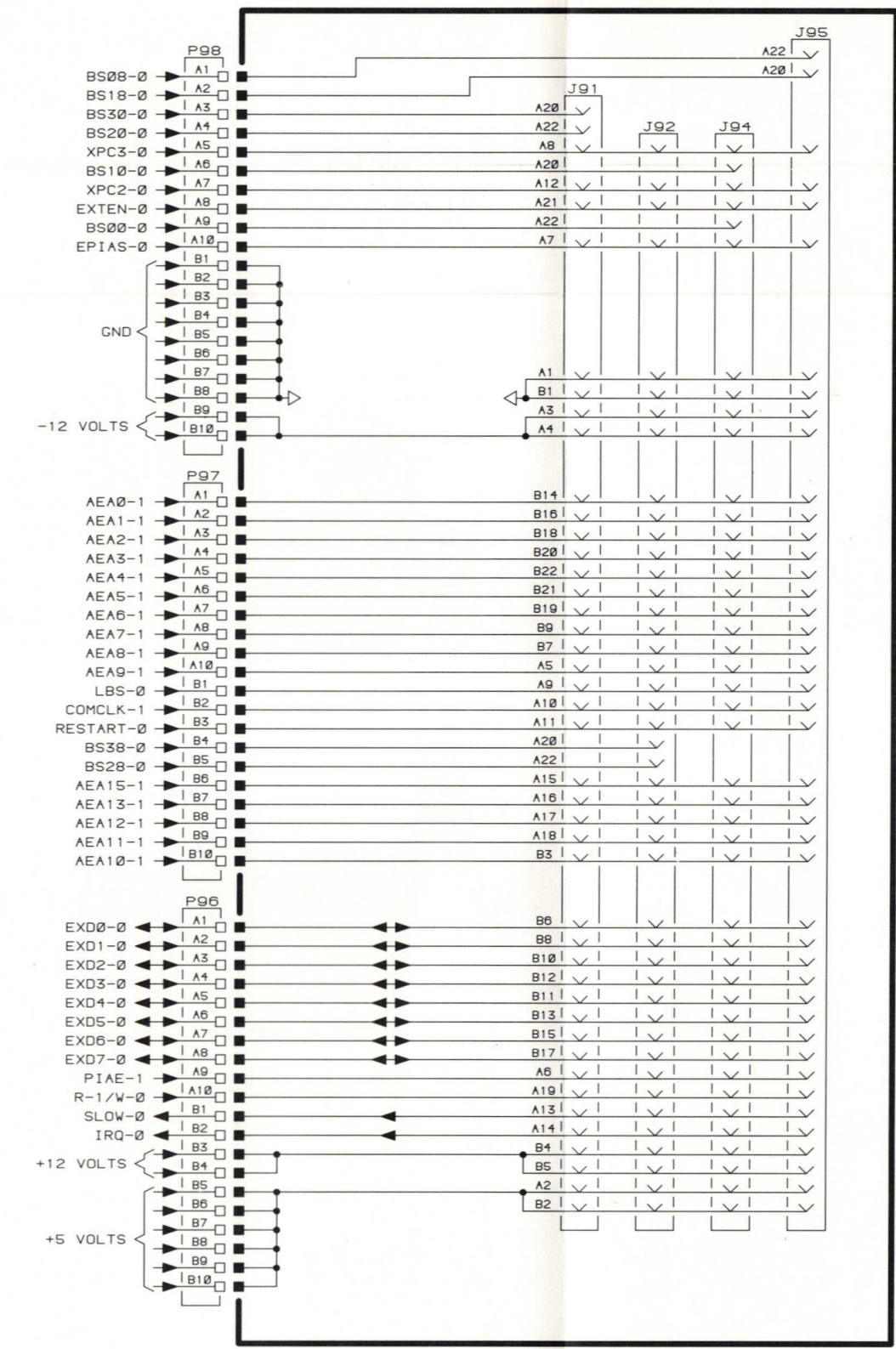

INSTRUMENT: 4052/4052A OPT. 2 & 3	NOTES: KEYS ARE LOCATED BETWEEN A6/B6 & A7/B7 OF J91, J92, J94, & J95 REV. JULY 1982 2829-S56	BOARD: 670-6206-00 CONNECTOR BOARD	ASSEMBLY-SHEET: A17-1 (1 OF 1)
---	---	---------------------------------------	--------------------------------------

Section 8

REPLACEABLE MECHANICAL PARTS

PARTS ORDERING INFORMATION

Replacement parts are available from or through your local Tektronix, Inc. Field Office or representative.

Changes to Tektronix instruments are sometimes made to accommodate improved components as they become available, and to give you the benefit of the latest circuit improvements developed in our engineering department. It is therefore important, when ordering parts, to include the following information in your order: Part number, instrument type or number, serial number, and modification number if applicable.

If a part you have ordered has been replaced with a new or improved part, your local Tektronix, Inc. Field Office or representative will contact you concerning any change in part number.

Change information, if any, is located at the rear of this manual.

ITEM NAME

In the Parts List, an Item Name is separated from the description by a colon (:). Because of space limitations, an Item Name may sometimes appear as incomplete. For further Item Name identification, the U.S. Federal Cataloging Handbook H6-1 can be utilized where possible.

FIGURE AND INDEX NUMBERS

Items in this section are referenced by figure and index numbers to the illustrations.

INDENTATION SYSTEM

This mechanical parts list is indented to indicate item relationships. Following is an example of the indentation system used in the description column.

```

1 2 3 4 5           Name & Description
Assembly and/or Component
Attaching parts for Assembly and/or Component
    --- * ---
Detail Part of Assembly and/or Component
Attaching parts for Detail Part
    --- * ---
Parts of Detail Part
Attaching parts for Parts of Detail Part
    --- * ---
  
```

Attaching Parts always appear in the same indentation as the item it mounts, while the detail parts are indented to the right. Indented items are part of, and included with, the next higher indentation. The separation symbol --- * --- indicates the end of attaching parts.

Attaching parts must be purchased separately, unless otherwise specified.

ABBREVIATIONS

#	INCH	ELECTRN	ELECTRON	IN	INCH	SE	SINGLE END
ACTR	NUMBER SIZE	ELEC	ELECTRICAL	INCAND	INCANDESCENT	SECT	SECTION
ADPTR	ACTUATOR	ELCTLT	ELECTROLYTIC	INSUL	INSULATOR	SEMICON	SEMICONDUCTOR
ALIGN	ADAPTER	ELEM	ELEMENT	INTL	INTERNAL	SHLD	SHIELD
AL	ALIGNMENT	EPL	ELECTRICAL PARTS LIST	LPHLDR	LAMPHOLDER	SHLDR	SHOULDERED
ASSEM	ALUMINUM	EQPT	EQUIPMENT	MACH	MACHINE	SKT	SOCKET
ASSY	ASSEMBLED	EXT	EXTERNAL	MECH	MECHANICAL	SL	SLIDE
ATTEN	ASSEMBLY	FIL	FILLISTER HEAD	MTG	MOUNTING	SLFLKG	SELF-LOCKING
AWG	ATTENUATOR	FLEX	FLEXIBLE	NIP	NIPPLE	SLVG	SLEEVING
BD	AMERICAN WIRE GAGE	FLH	FLAT HEAD	NON WIRE	NOT WIRE WOUND	SPR	SPRING
BRKT	BOARD	FLTR	FILTER	OBD	ORDER BY DESCRIPTION	SQ	SQUARE
BRS	BRACKET	FR	FRAME or FRONT	OD	OUTSIDE DIAMETER	SST	STAINLESS STEEL
BRZ	BRASS	FSTNR	FASTENER	OVH	OVAL HEAD	STL	STEEL
BSHG	BRONZE	FT	FOOT	PH BRZ	PHOSPHOR BRONZE	SW	SWITCH
CAB	BUSHING	FXD	FIXED	PL	PLAIN or PLATE	T	TUBE
CAP	CABINET	GSKT	GASKET	PLSTC	PLASTIC	TERM	TERMINAL
CER	CAPACITOR	HDL	HANDLE	PN	PART NUMBER	THD	THREAD
CHAS	CERAMIC	HEX	HEXAGON	PNH	PAN HEAD	THK	THICK
CKT	CHASSIS	HEX HD	HEXAGONAL HEAD	PWR	POWER	TNSN	TENSION
COMP	CIRCUIT	HEX SOC	HEXAGONAL SOCKET	RCPT	RECEPTACLE	TPG	TAPPING
CONN	COMPOSITION	HLCPS	HELICAL COMPRESSION	RES	RESISTOR	TRH	TRUSS HEAD
COV	CONNECTOR	HLEXT	HELICAL EXTENSION	RGD	RIGID	V	VOLTAGE
CPLG	COVER	HV	HIGH VOLTAGE	RLF	RELIEF	VAR	VARIABLE
CRT	COUPLING	IC	INTEGRATED CIRCUIT	RTNR	RETAINER	W/	WITH
DEG	CATHODE RAY TUBE	ID	INSIDE DIAMETER	SCH	SOCKET HEAD	WSHR	WASHER
DWR	DEGREE	IDENT	IDENTIFICATION	SCOPE	OSCILLOSCOPE	XFMR	TRANSFORMER
	DRAWER	IMPLR	IMPELLER	SCR	SCREW	XSTR	TRANSISTOR

REPLACEABLE MECHANICAL PARTS

CROSS INDEX—MFR. CODE NUMBER TO MANUFACTURER

Mfr. Code	Manufacturer	Address	City, State, Zip
000AE	GARDNER SPRING COMPANY	1115 N UTICA	TULSA, OK 74110
000AH	STANDARD PRESSED STEEL CO., UNBRAKO DIV.	8535 DICE ROAD	SANTA FE SPRINGS, CA 90670
000BK	STAUFFER SUPPLY	105 SE TAYLOR	PORTLAND, OR 97214
000CY	NORTHWEST FASTENER SALES, INC.	7923 SW CIRRUUS DRIVE	BEAVERTON, OR 97005
000JA	J. PHILLIP INDUSTRIES INC.	5713 NORTHWEST HIGHWAY	CHICAGO, ILL 60646
000LI	TOPTRON CORP		TOKYO, JAPAN
00779	AMP, INC.	P.O. BOX 3608	HARRISBURG, PA 17105
01295	TEXAS INSTRUMENTS, INC. SEMICONDUCTOR GROUP	P.O. BOX 5012	DALLAS, TX 75222
01881	ANACONDA AMERICAN BRASS COMPANY, A DIV. OF ANACONDA COMPANY	414 MEADOW STREET	WATERBURY, CT 06720
01963	CHERRY ELECTRICAL PRODUCTS CORPORATION	3600 SUNSET AVENUE	WAUKEGAN, IL 60085
02777	HOPKINS ENGINEERING COMPANY	12900 FOOTHILL BLVD.	SAN FERNANDO, CA 91342
04009	ARROW-HART, INC.	103 HAWTHORNE STREET	HARTFORD, CT 06106
04919	COMPONENT MANUFACTURING SERVICE, INC.	1 COMPONENT PARK WEST	BRIDGEWATER, MA 02379
04963	MINNESOTA MINING AND MFG. CO., ADHESIVES COATINGS AND SEALERS DIVISION	3M CENTER	ST. PAUL, MN 55101
05574	VIKING INDUSTRIES, INC.	21001 NORDHOFF STREET	CHATSORTH, CA 91311
05820	WAKEFIELD ENGINEERING, INC.	AUDUBON ROAD	WAKEFIELD, MA 01880
06383	PANDUIT CORPORATION	17301 RIDGELAND	TINLEY PARK, IL 60477
07322	MINNESOTA RUBBER CO.	3630 WOODDALE AVENUE	MINNEAPOLIS, MN 55416
07416	NELSON NAME PLATE CO.	3191 CASITAS	LOS ANGELES, CA 90039
08261	SPECTRA-STRIP CORP.	7100 LAMPSON AVE.	GARDEN GROVE, CA 92642
09922	BURNDY CORPORATION	RICHARDS AVENUE	NORWALK, CT 06852
11897	PLASTIGLIDE MFG. CORPORATION	P O BOX 867, 1757 STANFORD ST.	SANTA MONICA, CA 90406
11983	NORTRONICS COMPANY, INC.	8101 10TH AVENUE NORTH	MINNEAPOLIS, MN 55427
12327	FREEWAY CORPORATION	9301 ALLEN DRIVE	CLEVELAND, OH 44125
15819	SINCLAIR AND RUSH INC.	6919 SOUTH BROADWAY	ST. LOUIS, MO 63111
18722	RCA CORP., SOLID STATE DIVISION	CRESTWOOD ROAD	MOUNTAINTOP, PA 18707
22526	BERG ELECTRONICS, INC.	YOUK EXPRESSWAY	NEW CUMBERLAND, PA 17070
22599	ESNA, DIV. OF AMERACE CORPORATION	16150 STAGG STREET	VAN NUYS, CA 91409
24931	SPECIALTY CONNECTOR CO., INC.	2620 ENDRESS PLACE	GREENWOOD, IN 46142
26365	GRIES REPRODUCER CO., DIV. OF COATS AND CLARK, INC.	125 BEECHWOOD AVE.	NEW ROCHELLE, NY 10802
27264	MOLEX PRODUCTS CO.	5224 KATRINE AVE.	DOWNERS GROVE, IL 60515
28520	HEYMAN MFG. CO.	147 N. MICHIGAN AVE.	KENILWORTH, NJ 07033
50778	PORTESCAP, US	730 FIFTH AVENUE	NEW YORK, NEW YORK 10019
52905	SIMPLEX MFG. COMPANY	5224 NE 42ND AVENUE	PORTLAND, OREGON 97218
55285	BERGQUIST CO. INC.	5300 EDINA INDUSTRIAL BLVD	MINNEAPOLIS, MN 55435
56289	SPRAGUE ELECTRIC CO.	87 MARSHALL ST.	NORTH ADAMS, MA 01247
70276	ALLEN MFG. CO.	P. O. DRAWER 570	HARTFORD, CT 06101
70485	ATLANTIC INDIA RUBBER WORKS, INC.	571 W. POLK ST.	CHICAGO, IL 60607
70903	BELDEN CORP.	2000 S BATAVIA AVENUE	GENEVA, IL 60134
71468	ITT CANNON ELECTRIC	666 E. DYER RD.	SANTA ANA, CA 92702
71785	TRW, CINCH CONNECTORS	1501 MORSE AVENUE	ELK GROVE VILLAGE, IL 60007
73743	FISCHER SPECIAL MFG. CO.	446 MORGAN ST.	CINCINNATI, OH 45206
73803	TEXAS INSTRUMENTS, INC., METALLURGICAL MATERIALS DIV.	34 FOREST STREET	ATTLEBORO, MA 02703
74868	BUNKER-RAMO CORP., THE AMPHENOL RF DIV.	33 E. FRANKLIN ST.	DANBURY, CT 06810
74921	ITEN FIBRE CO.,	4001 BENEFIT AVE., P O BOX 9	ASHTABULA, OH 44004
77250	PHEOLL MANUFACTURING CO., DIVISION OF ALLIED PRODUCTS CORP.	5700 W. ROOSEVELT RD.	CHICAGO, IL 60650
78189	ILLINOIS TOOL WORKS, INC. SHAKEPROOF DIVISION	ST. CHARLES ROAD	ELGIN, IL 60120
79136	WALDES, KOHINOOR, INC.	47-16 AUSTEL PLACE	LONG ISLAND CITY, NY 11101
80009	TEKTRONIX, INC.	P O BOX 500	BEAVERTON, OR 97077
81041	HOWARD INDUSTRIES, DIVISION OF MSL INDUSTRIES, INC.	P O BOX 287	MILFORD, IL 60953
83385	CENTRAL SCREW CO.	2530 CRESCENT DR.	BROADVIEW, IL 60153
85471	BOYD, A. B., CO.	2527 GRANT AVENUE	SAN LEANDRO, CA 94579
86445	PENN FIBRE AND SPECIALTY CO., INC.	2032 E. WESTMORELAND ST.	PHILADELPHIA, PA 19134
86928	SEASTROM MFG. COMPANY, INC.	701 SONORA AVENUE	GLENDALE, CA 91201
87308	N. L. INDUSTRIES, INC., SOUTHERN SCREW DIV.	P. O. BOX 1360	STATESVILLE, NC 28677
91260	CONNOR SPRING AND MFG. CO.	1729 JUNCTION AVE.	SAN JOSE, CA 95112
93907	TEXTRON INC. CAMCAR DIV	600 18TH AVE	ROCKFORD, IL 61101
95987	WECKESSER CO., INC.	4444 WEST IRVING PARK RD.	CHICAGO, IL 60641
98291	SEALECTRO CORP.	225 HOYT	MAMARONECK, NY 10544

CROSS INDEX—MFR. CODE NUMBER TO MANUFACTURER

Mfr. Code	Manufacturer	Address	City, State, Zip
98938	PITTMAN CORPORATION, A SUBSIDIARY OF PENN ENGINEERING AND MFG. CORPORATION	P O BOX 150 W PARK AVE.	SELLERSVILLE, PA 18960
S3109	C/O PANEL COMPONENTS CORP.	P.O. BOX 6626	SANTA ROSA, CA 95406
S3629	PANEL COMPONENTS CORP.	2015 SECOND ST.	BERKELEY, CA 94170

REPLACEABLE MECHANICAL PARTS

Fig. & Index No.	Tektronix Part No.	Serial/Model No. Eff	Dscont	Qty	1	2	3	4	5	Name & Description	Mfr Code	Mfr Part Number
1-1	390-0490-03			1						CAB.TOP,CALC:W/BRACKETS & CLIP *****ATTACHING PARTS*****	80009	390-0490-03
-2	212-0543-00			2						SCREW,MACHINE:10-32 X 3.750 HEX HD	83385	OBD
-3	210-0805-00			2						WASHER,FLAT:0.204 ID X 0.438 INCH OD,ST	12327	OBD
-4	210-0010-00			2						WASHER,LOCK:INT,0.20 ID X 0.376" OD,STL	78189	1210-00-00-0541C
-5	348-0020-00			2						GROMMET,RUBBER:0.25 INCH	70485	374
-6	212-0507-00			2						SCREW,MACHINE:10-32 X 0.375 INCH,PNH STL *****END ATTACHING PARTS*****	83385	OBD
	334-3741-00			1						MARKER,IDENT:MKD FIRMWARE LEVEL	80009	334-3741-00
-7	334-3374-00			1						MARKER,IDENT:MARKED TEKTRONIX	80009	334-3374-00
-8	333-2510-00			1						PANEL,FRONT:4052	80009	333-2510-00
-9	426-1253-01			1						FRAME SECT,CAB.:FRONT *****ATTACHING PARTS*****	80009	426-1253-01
-10	211-0559-00			2						SCREW,MACHINE:6-32 X 0.375" 100 DEG,FLH ST	83385	OBD
-11	211-0512-00			2						SCREW,MACHINE:6-32 X 0.50" 100 DEG,FLH ST	83385	OBD
-12	212-0075-00			2						SCREW,MACHINE:8-32 X 0.250,TRH,STL,NI PL *****END ATTACHING PARTS*****	77250	OBD
-13	131-1846-00			1						CONTACT,ELEC:GROUNDING *****ATTACHING PARTS*****	80009	131-1846-00
-14	213-0088-00			1						SCR,TPG,THD CTG:4-24 X 0.25 INCH,PNH STL *****END ATTACHING PARTS*****	83385	OBD
-15	260-1842-00			1						SWITCH,ROCKER:DPST,16A,250VAC (PART OF 175-2302-00)	04009	2600-11E 718
-16	200-2301-00			1						COVER,SWITCH:POWER,SILICONE RUBBER (PART OF 175-2302-00)	80009	200-2301-00
-17	390-0483-01	B010100	B020955	1						CABINET SIDE:LEFT	80009	390-0483-01
	390-0700-00	B020956		1						CAB.SIDE,CALC:LEFT,FINISHED	80009	390-0700-00
-18	390-0484-01	B010100	B020955	1						CABINET SIDE:RIGHT	80009	390-0484-01
	390-0699-00	B020956		1						CAB.SIDE,CALC:RIGHT,FINISHED *****ATTACHING PARTS*****	80009	390-0699-00
-19	211-0510-00	B010100	B020955	6						SCREW,MACHINE:6-32 X 0.375,PNH,STL,CD PL	83385	OBD
	211-0510-00	B020956		10						SCREW,MACHINE:6-32 X 0.375,PNH,STL,CD PL	83385	OBD
-20	210-0006-00	B010100	B020955	6						WASHER,LOCK:#6 INTL,0.018 THK,STL CD PL	78189	1206-00-00-0541C
	210-0006-00	B020956		10						WASHER,LOCK:#6 INTL,0.018 THK,STL CD PL *****END ATTACHING PARTS*****	78189	1206-00-00-0541C
-21	348-0178-00			4						BUMPER,PLASTIC:2.0 W X 0.40 INCH H	80009	348-0178-00
-22	348-0177-00			4						PAD,CABINET FT:1.25 W X 0.50 INCH H *****ATTACHING PARTS*****	80009	348-0177-00
-23	213-0041-00			8						SCR,TPG,THD CTG:6-32 X 0.375 INCH,TRH STL	83385	OBD
-24	210-0803-00			8						WASHER,FLAT:0.15 ID X 0.032 THK,STL CD *****END ATTACHING PARTS*****	12327	OBD
-25	407-1696-00			1						BRACKET,ANGLE:REAR PANEL,ALUMINUM *****ATTACHING PARTS*****	80009	407-1696-00
-26	212-0004-00			2						SCREW,MACHINE:8-32 X 0.312 INCH,PNH STL	83385	OBD
-27	210-0008-00			1						WASHER,LOCK:INTL,0.172 ID X 0.331"OD,S *****END ATTACHING PARTS*****	78189	1208-00-00-0541C
-28	390-0482-02	B010100	B023163	1						CAB.BOT,CALC:	80009	390-0482-02
	390-0482-04	B023164		1						CABINET BOTTOM:	80009	390-0482-04
-29	334-3410-00			1						OVERLAY,KYBD:MARKED USER DEFINABLE/LINE	80009	334-3410-00
-30	333-2499-00			1						PANEL,FRONT: *****ATTACHING PARTS*****	80009	333-2499-00
-31	211-0019-00			10						SCREW,MACHINE:4-40 X 1.0 INCH,PNH STL *****END ATTACHING PARTS*****	83385	OBD
-32	-----			1						KEYBOARD,CALC:(SEE A7 REPL) *****ATTACHING PARTS*****		
-33	211-0542-00			2						SCREW,MACHINE:6-32 X 0.312 INCH,TRH STL	83385	OBD
-34	210-0803-00			2						WASHER,FLAT:0.15 ID X 0.032 THK,STL CD	12327	OBD
-35	210-0009-00			2						WASHER,LOCK:EXT,0.193ID X 0.40" OD,STL *****END ATTACHING PARTS*****	78189	1110-00
	-----			-						KEYBOARD ASSY INCLUDES:		
-36	260-1393-01			2						.SWITCH,PUSH:SPST,NO,KYBD SW,HIGH ACTG F	01963	M51-0101
-37	118-0081-00			1						.SWITCH,PUSH:4051 KEYBOARD	01963	M61-0800
-38	260-1393-00			95						.SWITCH,PUSH:SPST,NO KEYBOARD SWITCH	01963	M61-0100

REPLACEABLE MECHANICAL PARTS

Fig. & Index No.	Tektronix Part No.	Serial/Model No.		Qty						Name & Description	Mfr	
		Eff	Dscont		1	2	3	4	5		Code	Mfr Part Number
1-39	119-0423-00			1						.SPACE BAR ASSY:	01963	B99-0003
-40	366-1790-02			1						.PUSH BUTTON:GOLD,HOME PAGE	01963	223-0201
	366-1790-01			1						.PUSH BUTTON:TV GRAY,LEFT BRACE/LEFT BRK	01963	223-0187
	366-1766-05			1						.PUSH BUTTON:LT GRAY,RIGHT BRACKET/1	01963	223-0094
	366-1790-18			1						.PUSH BUTTON:	01963	223-0180
	366-1766-03			1						.PUSH BUTTON:LT GRAY,#/3	01963	223-0096
	366-1766-02			1						.PUSH BUTTON:LT GRAY,DOLLAR/4	01963	223-0097
	366-1766-12			1						.PUSH BUTTON:LT GRAY,%/5	01963	223-0098
	366-1790-22			1						.PUSH BUTTON:TEK TAN,&/6	01963	223-0181
	366-1790-21			1						.PUSH BUTTON:TEK TAN '/7	01963	223-0182
-41	366-1790-19			1						.PUSH BUTTON:TEK TAN,(/8	01963	223-0183
	366-1790-20			1						.PUSH BUTTON:TEK TAN,)/9	01963	223-0184
	366-1790-17			1						.PUSH BUTTON:TEK TAN,0	01963	223-0190
	366-1790-16			1						.PUSH BUTTON:TEK TAN,*:/	01963	223-0185
	366-1790-15			1						.PUSH BUTTON:TEK TAN,=/-	01963	223-0186
	366-1790-14			1						.PUSH BUTTON:TV GRAY,RIGHT BRACE/RIGHT	01963	223-0188
	366-1790-13			1						.PUSH BUTTON:TV GRAY,BACK SPACE	01963	223-0191
	366-1790-12			1						.PUSH BUTTON:TV GRAY,ESC	01963	223-1128
	366-1790-11			1						.PUSH BUTTON:TV GRAY,TILDE/ARROW UP	01963	223-1129
	366-1766-63			1						.PUSH BUTTON:LT GRAY,Q	01963	223-1068
	366-1766-20			1						.PUSH BUTTON:LT GRAY,W	01963	223-1069
	366-1766-52			1						.PUSH BUTTON:LT GRAY,E	01963	223-1070
	366-1766-64			1						.PUSH BUTTON:LT GRAY,R	01963	223-1071
	366-1766-65			1						.PUSH BUTTON:LT GRAY,T	01963	223-1072
	366-1766-70			1						.PUSH BUTTON:LT GRAY,Y	01963	223-1073
	366-1766-67			1						.PUSH BUTTON:LT GRAY,U	01963	223-1074
	366-1766-43			1						.PUSH BUTTON:DK GRAY,1	01963	223-1075
	366-1766-61			1						.PUSH BUTTON:LT GRAY,O	01963	223-1076
	366-1766-62			1						.PUSH BUTTON:LT GRAY,P	01963	223-1077
	366-1790-10			1						.PUSH BUTTON:TEK TAN,@/BACK SPACE	01963	223-1130
	366-1790-09			1						.PUSH BUTTON:TV GRAY,LF	01963	223-1131
	366-1790-08			1						.PUSH BUTTON:TV GRAY,RETURN	01963	223-5554
	366-1790-07			1						.PUSH BUTTON:TV GRAY,TAB	01963	228-2016
	366-1766-42			1						.PUSH BUTTON:DK GRAY,CTRL	01963	228-3106
	366-1766-48			1						.PUSH BUTTON:LT GRAY,A	01963	228-6703
	366-1766-66			1						.PUSH BUTTON:LT GRAY,S	01963	228-6704
	366-1766-51			1						.PUSH BUTTON:LT GRAY,D	01963	228-6705
	366-1766-53			1						.PUSH BUTTON:LT GRAY,F	01963	228-5921
	366-1766-54			1						.PUSH BUTTON:LT GRAY,G	01963	228-6707
	366-1766-55			1						.PUSH BUTTON:LT GRAY,H	01963	228-6708
	366-1766-56			1						.PUSH BUTTON:LT GRAY,J	01963	228-5922
	366-1766-57			1						.PUSH BUTTON:LT GRAY,K	01963	228-6710
	366-1766-58			1						.PUSH BUTTON:LT GRAY,L	01963	228-6711
	366-1790-06			1						.PUSH BUTTON:TEK TAN,+;/	01963	228-6712
	366-1790-05			1						.PUSH BUTTON:TV GRAY,BACK SLASH/'	01963	228-6674
	366-1790-04			1						.PUSH BUTTON:TV GRAY,RUB OUT	01963	228-6887
-42	366-1790-03			1						.PUSH BUTTON:TV GRAY,TTY LOCK	01963	223-2106
	366-1766-29			1						.PUSH BUTTON:DK GRAY,SHIFT	01963	223-4502
	366-1766-71			1						.PUSH BUTTON:LT GRAY,Z	01963	223-2056
	366-1766-69			1						.PUSH BUTTON:LT GRAY,X	01963	223-2057
	366-1766-50			1						.PUSH BUTTON:LT GRAY,C	01963	223-2058
	366-1766-68			1						.PUSH BUTTON:LT GRAY,V	01963	223-2059
	366-1766-49			1						.PUSH BUTTON:LT GRAY,B	01963	223-2060
	366-1766-60			1						.PUSH BUTTON:LT GRAY,N	01963	223-2061
	366-1766-66			1						.PUSH BUTTON:LT GRAY,S	01963	228-6704
	366-1766-28			1						.PUSH BUTTON:LT GRAY,</	01963	223-2064
	366-1766-27			1						.PUSH BUTTON:LT GRAY,>/	01963	223-2064
	366-1766-26			1						.PUSH BUTTON:DK GRAY,?/SLASH	01963	223-2065
	366-1766-29			1						.PUSH BUTTON:DK GRAY,SHIFT	01963	223-4502
	366-1790-00			1						.PUSH BUTTON:GOLD,BREAK	01963	223-2105
	366-1790-23			1						.PUSH BUTTON:TV GRAY,(01963	228-6675
	366-1790-24			1						.PUSH BUTTON:TEK TAN,ENTER EXP	01963	228-6889
	366-1790-23			1						.PUSH BUTTON:TV GRAY,(01963	228-6675

REPLACEABLE MECHANICAL PARTS

Fig. & Index No.	Tektronix Part No.	Serial/Model No.		Qty	1	2	3	4	5	Name & Description	Mfr Code	Mfr Part Number
		Eff	Dscont									
1-	366-1790-26			1						.PUSH BUTTON:TV GRAY,ARROW UP	01963	228-6676
	366-1790-27			1						.PUSH BUTTON:TEK TAN,7	01963	228-6723
	366-1790-28			1						.PUSH BUTTON:TEK TAN,8	01963	228-6724
	366-1790-29			1						.PUSH BUTTON:TEK TAN,9	01963	228-6725
	366-1790-30			1						.PUSH BUTTON:TV GRAY,/	01963	228-6677
	366-1790-41			1						.PUSH BUTTON:TEK TAN,4	01963	228-6726
	366-1790-40			1						.PUSH BUTTON:TEK TAN,5	01963	228-3615
	366-1790-29			1						.PUSH BUTTON:TEK TAN,9	01963	228-6725
	366-1790-38			1						.PUSH BUTTON:TV GRAY,*	01963	228-6890
	366-1790-37			1						.PUSH BUTTON:TEK TAN,1	01963	228-6728
	366-1790-36			1						.PUSH BUTTON:TEK TAN,2	01963	228-6729
	366-1790-35			1						.PUSH BUTTON:TEK TAN,3	01963	228-6730
	366-1790-34			1						.PUSH BUTTON:TV GRAY,-	01963	228-6678
	366-1790-33			1						.PUSH BUTTON:TEK TAN,0	01963	228-0136
	366-1790-32			1						.PUSH BUTTON:TEK TAN,.	01963	228-6731
	366-1790-31			1						.PUSH BUTTON:TV GRAY,+	01963	228-6679
-43	366-1502-00			10						PUSH BUTTON:SIL GY,0.715 X 0.23 X 0.41	80009	366-1502-00
-44	366-1671-00			10						PUSH BUTTON:BLANK,DARK GRAY	80009	366-1671-00
-45	337-2662-00			1						SHIELD,ELEC:KEYBOARD	80009	337-2662-00
										*****ATTACHING PARTS*****		
-46	211-0021-00			2						SCREW,MACHINE:4-40 X 1.25 INCH,PNH STL	83385	OBD
										*****END ATTACHING PARTS*****		
-47	175-2302-00			1						CA ASSY,SP,ELEC:4,18 AWG,25.0 L	80009	175-2302-00
-48	131-0945-00			4						.CONTACT,ELEC:CONNECTOR,BRASS TIN PL	27264	02-09-2101
-49	131-0946-00			1						.CONNECTOR BODY,.;FEMALE,4 CONTACT	27264	03-09-2041
	-----			-						(SEE P1004 REPL)		
-50	175-1577-00			AR						.CABLE,SP,ELEC:4,18 AWG,TWISTED	80009	175-1577-00

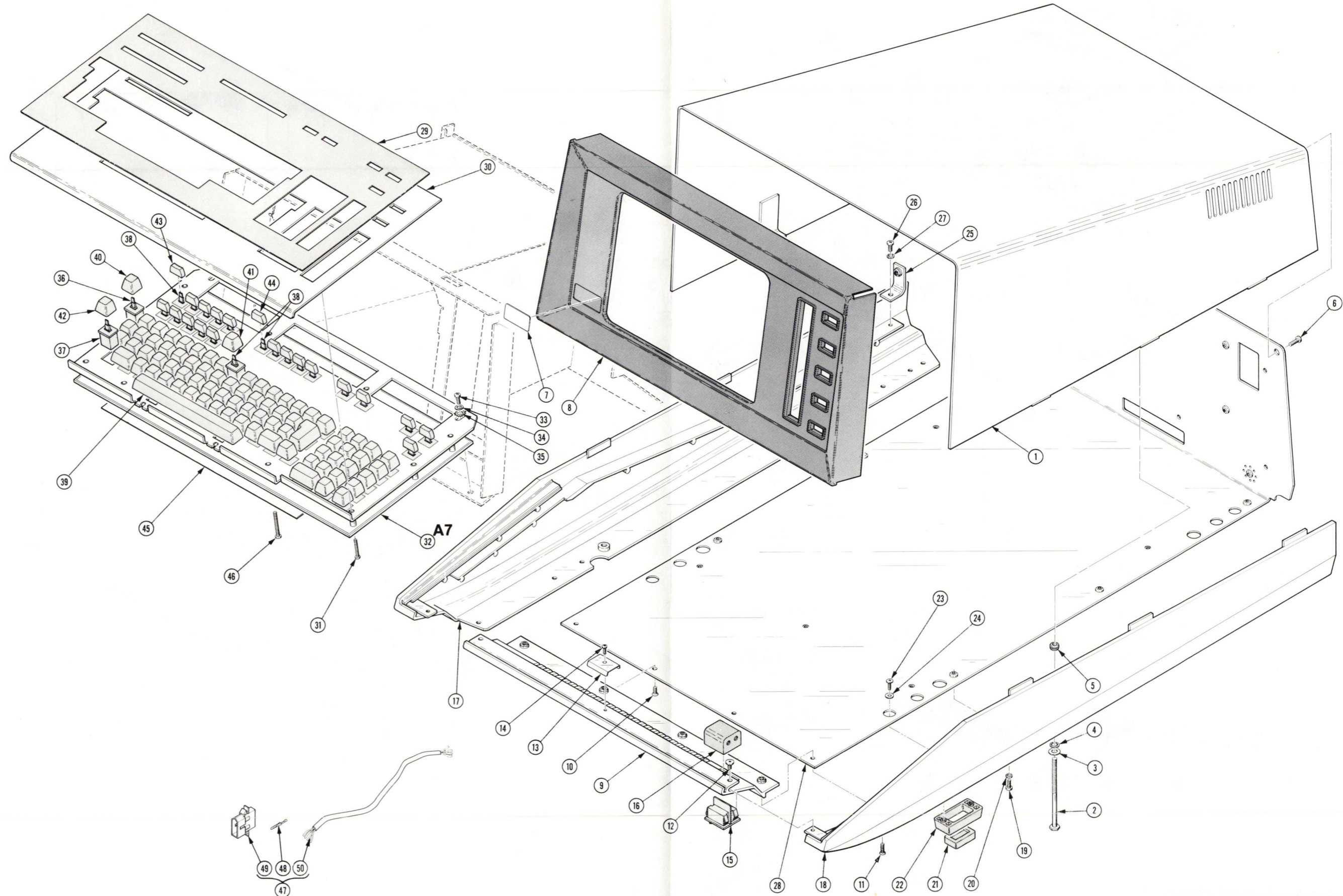

REV JUL 1982

4052/4052A PARTS AND SCHEMATICS

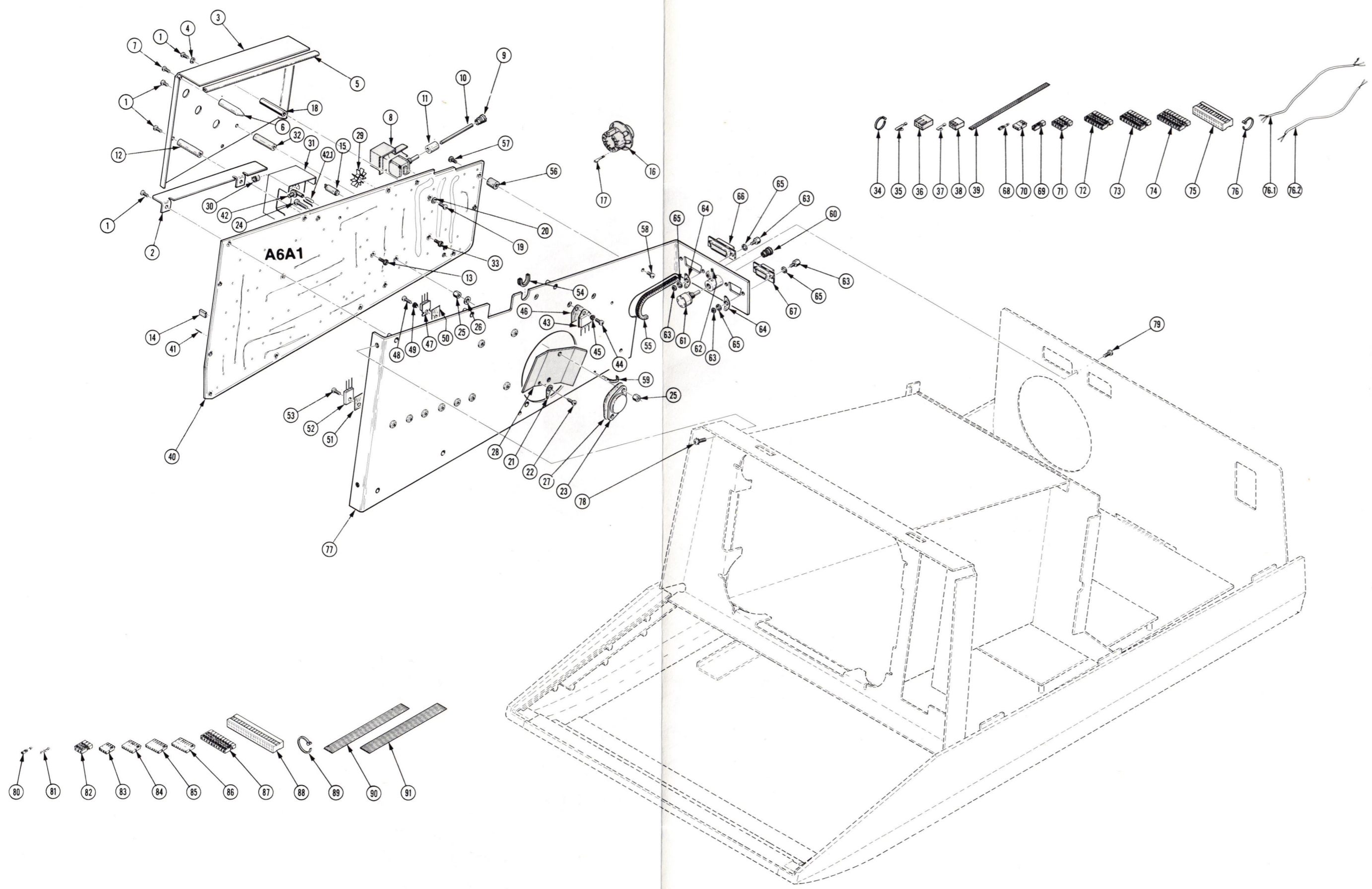

REPLACEABLE MECHANICAL PARTS

Fig. & Index No.	Tektronix Part No.	Serial/Model No.		Qty	1	2	3	4	5	Name & Description	Mfr Code	Mfr Part Number
		Eff	Dscont									
2-	-----			1						CKT BOARD ASSY:HARD COPY DISPLAY(SEE A6 RE *****ATTACHING PARTS)*****		
-1	211-0008-00			9						SCREW,MACHINE:4-40 X 0.250,PNH,STL,CD PL *****END ATTACHING PARTS)*****	83385	OBD
	-----			-						CKT BOARD ASSY INCLUDES:		
-2	337-2265-00			1						.SHIELD,ELEC:CIRCUIT CARD	80009	337-2265-00
-3	337-2251-00			1						.SHIELD,ELEC:HIGH VOLTAGE POWER SUPPLY *****ATTACHING PARTS)*****	80009	337-2251-00
-4	210-0004-00			1						.WASHER,LOCK:#4 INTL,0.015 THK,STL CD PL *****END ATTACHING PARTS)*****	000BK	OBD
-5	252-0571-00			1						.NEOPRENE EXTR:CHAN,0.234 X 0.156	85471	DIE#1353
-6	129-0588-00			1						.POST,ELEC-MECH:1.4 L,W/4-40 THD,NYLON *****ATTACHING PARTS)*****	80009	129-0588-00
-7	211-0008-00			1						.SCREW,MACHINE:4-40 X 0.250,PNH,STL,CD PL *****END ATTACHING PARTS)*****	83385	OBD
-8	200-1327-00			1						.SHIELD,RESISTOR:	80009	200-1327-00
-9	366-0261-00	B010100	B010299	1						.KNOB:0.312 OD X 0.406 INCH LONG	80009	366-0261-00
	366-0261-02	B010300		1						.KNOB:GRAY,0.129 ID X 0.312 OD X	80009	366-0261-02
-10	384-1181-00			1						.EXTENSION SHAFT:1.840 INCH LONG	80009	384-1181-00
-11	376-0029-00			1						.CPLG,SHAFT,RGD:0.128 ID X 0.312 OD X 0.5"	80009	376-0029-00
	213-0075-00			1						..SETSCREW:4-40 X 0.094,STL BK OXD,HEX	000BK	OBD
-12	129-0369-00			1						.INSULATOR,STDF:1.370 INCH,W/4-40 THREAD *****ATTACHING PARTS)*****	80009	129-0369-00
-13	211-0040-00			1						.SCREW,MACHINE:4-40 X 0.25",BDGH PLSTC *****END ATTACHING PARTS)*****	26365	OBD
-14	131-0993-00			1						.BUS,CONDUCTOR:2 WIRE BLACK	00779	850100-01
-15	131-1834-00			2						.TERMINAL,STUD:0.89 L,W/NYLON INSULATOR	98291	023-3000-000-689
	136-0647-01			1						.SKT,PL-IN ELEK:ELCTR N TUBE,7 CONT,W/LEADS	80009	136-0647-01
-16	136-0278-00			1						..SOCKET,PLUG-IN:WITH PINS	80009	136-0278-00
-17	214-0464-00			7						..CONTACT,ELEC:CRT	80009	214-0464-00
-18	384-0616-00			1						.POST,ELEC-MECH:HEX,0.25 X 1.370 INCH LONG *****ATTACHING PARTS)*****	80009	384-0616-00
-19	211-0008-00			1						.SCREW,MACHINE:4-40 X 0.250,PNH,STL,CD PL	83385	OBD
-20	210-0004-00			1						.WASHER,LOCK:#4 INTL,0.015 THK,STL CD PL *****END ATTACHING PARTS)*****	000BK	OBD
-21	210-0201-00			1						.TERMINAL,LUG:0.12 ID,LOCKING,BRZ TIN PL *****ATTACHING PARTS)*****	86928	OBD
-22	213-0138-00			1						.SCR,TPG,TF:4-24 X 0.188 INCH,PNH STL *****END ATTACHING PARTS)*****	83385	OBD
-23	-----			1						.TRANSISTOR:(SEE A6A1Q432 REPL) *****ATTACHING PARTS)*****		
-24	211-0514-00			2						.SCREW,MACHINE:6-32 X 0.750 INCH,PNH STL	83385	OBD
-25	210-0561-00			4						.NUT,PLAIN,HEX.:0.188 INCH L,0.188 HEX BRS	80009	210-0561-00
-26	210-0935-00			2						.WASHER,NONMETAL:FIBER,0.14 ID X 0.375"OD *****END ATTACHING PARTS)*****	74921	OBD
-27	386-0978-00			1						.INSULATOR,PLATE:TRANSISTOR,MICA	80009	386-0978-00
-28	214-1713-01			1						.HEAT SINK,XSTR:TO-3,AL	80009	214-1713-01
-29	214-1292-00			1						.HEAT SINK,ELEC:TRANSISTOR	05820	205SB
-30	348-0055-00			1						.GROMMET,PLASTIC:0.25 INCH DIA	80009	348-0055-00
-31	337-2267-00			1						.SHIELD,ELEC:HV TRANSFORMER	80009	337-2267-00
-32	361-0137-00			1						.POST,ELEC-MECH:1.345 INCH,W/4-40 THREAD *****ATTACHING PARTS)*****	80009	361-0137-00
-33	211-0040-00			1						.SCREW,MACHINE:4-40 X 0.25",BDGH PLSTC *****END ATTACHING PARTS)*****	26365	OBD
-34	343-0549-00			1						.STRAP,TIEDOWN:0.091 W X 3.62 INCH LONG	06383	PLT1M
	198-3024-00			1						.WIRE SET,ELEC:	80009	198-3024-00
	198-3079-00			1						.WIRE SET,ELEC:	80009	198-3079-00
-35	131-1790-00			12						..CONTACT,ELEC:18-24 AWG,FEMALE,BRASS	27264	08-56-0105
-36	204-0671-00			4						..CONN BODY,PLUG:1 X 3 CONTACTS NYLON	27264	09-50-7031
-37	131-1815-00			15						..CONTACT,ELEC:22-30 AWG,FEMALE,BRASS	27264	08-56-0110
-38	204-0678-00			5						..CONN BODY,PL,EL:FOR 3 FEMALE CONTACTS	27264	10-17-2032
-39	175-0862-00			AR						..WIRE,ELECTRICAL:3 WIRE RIBBON	08261	SS-0322-1910610C
	175-0826-00			AR						..WIRE,ELECTRICAL:3 WIRE RIBBON	80009	175-0826-00

REPLACEABLE MECHANICAL PARTS

Fig. & Index No.	Tektronix Part No.	Serial/Model No. Eff	Dscont	Qty	1	2	3	4	5	Name & Description	Mfr Code	Mfr Part Number
2-40	----			1						.CKT BOARD ASSY:DISPLAY(SEE A6A1 REPL)		
-41	131-0589-00			60						..TERMINAL,PIN:0.46 L X 0.025 SQ	22526	48283-029
-42	352-0134-00			1						..HOLDER,COIL:TOROIDAL,0.472 X 0.417 INCH	80009	352-0134-00
-42.1	214-0506-00			1						..CONTACT,ELEC:0.045 SQ X 0.375 INCH L	80009	214-0506-00
-43	----			2						TRANSISTOR:(SEE CHASSIS Q1091,Q1092 REPL) *****ATTACHING PARTS*****		
-44	211-0012-00			2						SCREW,MACHINE:4-40 X 0.375,PNH STL CD PL	83385	OBD
-45	210-1171-00			2						WSHR,SHOULDERED:0.116 ID X 0.138 INCH OD *****END ATTACHING PARTS*****	52905	A7148516P2
-46	342-0311-00			2						INSULATOR,PLATE:TRANSISTOR,MICA	01295	64-21-023-212
-47	----			5						TRANSISTOR:(SEE CHASSIS Q1036,Q1039,Q1044, Q1059,AND Q1067 REPL) *****ATTACHING PARTS*****		
-48	211-0012-00			5						SCREW,MACHINE:4-40 X 0.375,PNH STL CD PL	83385	OBD
-49	210-1171-00			5						WSHR,SHOULDERED:0.116 ID X 0.138 INCH OD *****END ATTACHING PARTS*****	52905	A7148516P2
-50	342-0328-00			1						INSULATOR,PLATE:XSTR,ALUMINUM	80009	342-0328-00
-51	342-0203-00			8						INSULATOR,PLATE:XSTR,0.675 X 0.625 X 0.001	18722	DF103C
-52	----			4						TRANSISTOR:(SEE CHASSIS Q1069,Q1074, Q1084,AND Q1096 REPL) *****ATTACHING PARTS*****		
-53	211-0507-00			4						SCREW,MACHINE:6-32 X 0.312 INCH,PNH STL *****END ATTACHING PARTS*****	83385	OBD
-54	348-0115-01			1						GROMMET,PLASTIC:U-SHAPED	80009	348-0115-01
-55	255-0334-00			AR						PLASTIC CHANNEL:12.75 X 0.175 X 0.155,NYL	11897	122-37-2500
-56	129-0212-00			2						SPACER,POST:0.312 OD X 0.435 INCH L,NYL *****ATTACHING PARTS*****	80009	129-0212-00
-57	211-0040-00			2						SCREW,MACHINE:4-40 X 0.25",BDGH PLSTC	26365	OBD
-58	211-0008-00			2						SCREW,MACHINE:4-40 X 0.250,PNH,STL,CD PL *****END ATTACHING PARTS*****	83385	OBD
-59	343-0089-00			4						CLAMP,LOOP:LARGE	80009	343-0089-00
-60	366-0261-00	B010100	B010299	1						KNOB:0.312 OD X 0.406 INCH LONG	80009	366-0261-00
	366-0261-02	B010300		1						KNOB:GRAY,0.129 ID X 0.312 OD X	80009	366-0261-02
-61	----			1						RESISTOR,VAR:(SEE R1050 REPL) *****ATTACHING PARTS*****		
-62	213-0020-00			1						SETSCREW:6-32 X 0.125 INCH,HEX,SOC S *****END ATTACHING PARTS*****	70276	OBD
	179-2354-00			1						WIRING HARNESS,:DISPLAY *****ATTACHING PARTS*****	80009	179-2354-00
-63	131-0890-00			4						LOCK,CONNECTOR:4-40 X 0.312 L	71468	D 20418-2
-64	210-0204-00			2						TERMINAL,LUG:0.146 INCH DIA DE,45 DEG BE	78189	2157-06-01-2520N
-65	210-0004-00			8						WASHER,LOCK:#4 INTL,0.015 THK,STL CD PL *****END ATTACHING PARTS*****	000BK	OBD
	----			-						WIRING HARNESS INCLUDES:		
-66	131-0458-00			1						.CONNECTOR,RCPT,:15 PIN,FEMALE	71468	DA15S
-67	131-1006-00			1						.CONN,RCPT,ELEC:9 CONTACT,FEMALE	71468	DE 9S
-68	131-0621-00			31						.CONNECTOR,TERM:22-26 AWG,BRS & CU BE GOLD	22526	46231
	131-0622-00			5						.CONTACT,ELEC:0.577"L,28-32 AWG WIRE	22526	46241
	131-0707-00			22						.CONNECTOR,TERM:22-26 AWG,BRS & CU BE GOLD	22526	47439
	131-0708-00			3						.CONTACT,ELEC:0.48"L,28-32 AWG WIRE	22526	47437
	131-0792-00			4						.CONNECTOR,TERM:18-20 AWG,CU BE GOLD PL	22526	46221
-69	352-0197-00			1						.CONN BODY,PL,EL:1 WIRE BLACK	80009	352-0197-00
-70	352-0161-03			1						.CONN BODY,PL,EL:3 WIRE ORANGE	80009	352-0161-03
	352-0161-06			1						.CONN BODY,PL,EL:3 WIRE BLUE	80009	352-0161-06
-71	352-0200-00			1						.HLDR,TERM CONN:4 WIRE BLACK	80009	352-0200-00
	352-0200-05			1						.CONN BODY,PL,EL:4 WIRE GREEN	80009	352-0200-05
	352-0200-06			1						.CONN BODY,PL,EL:4 WIRE BLUE	80009	352-0200-06
-72	352-0203-03			1						.HLDR,TERM CONN:7 WIRE,ORANGE	80009	352-0203-03
-73	352-0204-03			1						.HLDR,TERM CONN:8 WIRE,ORANGE	80009	352-0204-03
	352-0204-04			1						.HLDR,TERM CONN:8 WIRE,YELLOW	80009	352-0204-04
-74	352-0205-02			1						.CONN BODY,PL,EL:9 WIRE RED	80009	352-0205-02
	352-0205-04			1						.CONN BODY,PL,EL:9 WIRE YELLOW	80009	352-0205-04
-75	352-0428-00			1						.CONN BODY,PLUG:2/12 FEM CONT	22526	65043-070

REPLACEABLE MECHANICAL PARTS

Fig. & Index No.	Tektronix Part No.	Serial/Model No.		Qty	1	2	3	4	5	Name & Description	Mfr Code	Mfr Part Number
		Eff	Dscont									
2-76	343-0549-00			20						.STRAP,TIEDOWN:0.091 W X 3.62 INCH LONG	06383	PLT1M
	346-0128-00			1						.STRAP,TIE DOWN:0.1W X 8.0" LONG,NYLON	06383	PLT2M
-76.1	175-0072-00			AR						.CABLE,RF:2 CONDUCTOR	80009	175-0072-00
-76.2	175-0152-01			AR						.CABLE,SP,ELEC:	80009	175-0152-01
-77	441-1291-00			1						CHAS,ELEC EQPT:LEFT *****ATTACHING PARTS)*****	80009	441-1291-00
-78	211-0534-00			2						SCR,ASSEM,WSHR:6-32 X 0.312 INCH,PNH STL	83385	OBD
-79	211-0507-00			1						SCREW,MACHINE:6-32 X 0.312 INCH,PNH STL *****END ATTACHING PARTS)*****	83385	OBD
	179-2355-00			1						WIRING HARNESS,,:POWER	80009	179-2355-00
-80	131-0621-00			17						.CONNECTOR,TERM:22-26 AWG,BRS & CU BE GOLD	22526	46231
-81	131-0707-00			53						.CONNECTOR,TERM:22-26 AWG,BRS & CU BE GOLD	22526	47439
-82	352-0199-02			1						.CONN BODY,PL,EL:3 WIRE RED	80009	352-0199-02
-83	352-0200-02			1						.CONN BODY,PL EL:4 WIRE RED	80009	352-0200-02
-84	352-0164-00			1						.CONN BODY,PL,EL:6 WIRE BLACK	80009	352-0164-00
-85	352-0165-00			1						.CONN BODY,PL,EL:7 WIRE BLACK	80009	352-0165-00
-86	352-0166-00			1						.CONN BODY,PL,EL:8 WIRE BLACK	80009	352-0166-00
-87	352-0206-01			1						.HLDR,TERM CONN:10 WIRE BROWN	80009	352-0206-01
-88	352-0429-00			1						.CONN BODY,PLUG:2/19 FEM CONT	22526	65043-071
-89	343-0549-00			9						.STRAP,TIEDOWN:0.091 W X 3.62 INCH LONG	06383	PLT1M
-90	175-0830-00			AR						.WIRE,ELECTRICAL:7 WIRE RIBBON	08261	SS-0726-710610C
-91	175-0831-00			AR						.WIRE,ELECTRICAL:8 WIRE RIBBON	08261	SS-0826-710610C

REPLACEABLE MECHANICAL PARTS

Fig. & Index No.	Tektronix Part No.	Serial/Model No.		Qty	Name & Description					Mfr Code	Mfr Part Number
		Eff	Dscont		1	2	3	4	5		
3-	----			1	POWER SUPPLY:(SEE A1 REPL) *****ATTACHING PARTS*****						
-1	212-0004-00			7	SCREW,MACHINE:8-32 X 0.312 INCH,PNH STL					83385	OBD
-2	210-0008-00			3	WASHER,LOCK:INTL,0.172 ID X 0.331"OD,S *****END ATTACHING PARTS*****					78189	1208-00-00-0541C
-3	200-2287-00			-	POWER SUPPLY ASSY INCLUDES: ..COVER,PWR,SPLY:TOP *****ATTACHING PARTS*****					80009	200-2287-00
-4	211-0507-00			2	..SCREW,MACHINE:6-32 X 0.312 INCH,PNH STL *****END ATTACHING PARTS*****					83385	OBD
-5	200-2288-00			1	..COVER,PWR,SPLY:BOTTOM *****ATTACHING PARTS*****					80009	200-2288-00
-6	211-0538-00			2	..SCREW,MACHINE:6-32 X 0.312"100 DEG,FLH ST *****END ATTACHING PARTS*****					83385	OBD
-7	175-2300-00			1	..CA ASSY,SP,ELEC:10,22 AWG,8.0 L					80009	175-2300-00
-8	131-1790-00			20	..CONTACT,ELEC:18-24 AWG,FEMALE,BRASS					27264	08-56-0105
-9	352-0462-00			2	..HLDR,TERM. CONN:10 FEMALE,NYLON					27264	09-50-7101
-9	175-5061-00			AR	..CABLE,SP,ELEC:10,18 AWG,RIBBON					08261	SS101819(1007)-X
-10	386-4038-00			1	..CKT BOARD ASSY:LINE SEL(SEE A1A1 REPL) ..SUPPORT,XFMR:					80009	386-4038-00
-11	119-0389-00	B010100	B024216	1	..FILTER,RAD INTE:115/230V,3A					02777	F11935-3
-11	119-1306-00	B024217		1	..FILTER,RFI:6A,250V,50-400HZ *****ATTACHING PARTS*****					56289	6JX5431A
-12	211-0025-00			2	..SCREW,MACHINE:4-40 X 0.375 100 DEG,FLH S					83385	OBD
-13	210-0586-00			2	..NUT,PL,ASSEM WA:4-40 X 0.25,STL *****END ATTACHING PARTS*****					83385	OBD
-14	200-1788-01			1	..COV,PROT,LINE:					80009	200-1788-01
-15	----			1	..XFMR,PWR,SDN&SU:(SEE A1A1T1001 REPL) *****ATTACHING PARTS*****						
-16	212-0515-00			4	..SCREW,MACHINE:10-32 X 2.250" HEX.HD STL					83385	OBD
-17	210-0812-00			4	..WASHER,NONMETAL:#10,FIBER					86445	OBD
-18	166-0227-00			4	..INS SLV,ELEC:0.187 ID X 1.50 INCH LONG					80009	166-0227-00
-19	220-0410-00			4	..NUT,EXTENDED WA:10-32 X 0.375 INCH,STL *****END ATTACHING PARTS*****					83385	OBD
-20	200-0237-03			1	..COVER,FUSE HLDR:					80009	200-0237-03
-21	200-2264-00			1	..CAP, FUSEHOLDER:3AG FUSES					S3629	FEK 031 1666
-22	204-0832-00			1	..BODY,FUSEHOLDER:3AG,5 X 20MM FUSES					S3629	031.1673(MDLFEU)
-22.1	210-1039-00			1	..WASHER,LOCK:INT,0.521 ID X 0.625 INCH O					24931	OBD
-23	210-0202-00			1	..TERMINAL,LUG:0.146 ID,LOCKING,BRZ TINNED *****ATTACHING PARTS*****					78189	2104-06-00-2520N
-24	211-0512-00			1	..SCREW,MACHINE:6-32 X 0.50" 100 DEG,FLH S					83385	OBD
-25	210-0457-00			2	..NUT,PL,ASSEM WA:6-32 X 0.312,STL CD PL *****END ATTACHING PARTS*****					83385	OBD
-25.1	334-3379-02			1	..MARKER,IDENT:MARKED GROUND SYMBOL					80009	334-3379-02
-26	348-0056-00			1	..GROMMET,PLASTIC:0.375 INCH DIA					80009	348-0056-00
-27	343-0213-00			1	..CLAMP,LOOP:0.2 ID,PLASTIC					80009	343-0213-00
	198-4188-00			1	..WIRE SET,ELEC:					80009	198-4188-00
	175-2301-00			1	..CA ASSY,SP,ELEC:4,18 AWG,14.5 L					80009	175-2301-00
-28	131-0947-00			1	..CONN BODY,RCPT:MALE,SNAP-IN PNL MT,4 CO					27264	03-09-1041
-29	131-0948-00			4	..CONTACT,ELEC:CONNECTOR,BRASS TIN PL					27264	02-09-1103
-30	175-1577-00			AR	..CABLE,SP,ELEC:4,18 AWG,TWISTED					80009	175-1577-00
-31	----			1	..CKT BOARD ASSY:(SEE A1A1A1 REPL) *****ATTACHING PARTS*****						
-32	211-0008-00			5	..SCREW,MACHINE:4-40 X 0.250,PNH,STL,CD PL *****END ATTACHING PARTS*****					83385	OBD
-33	----			-	..CKT BOARD ASSY INCLUDES: ..MICROCIRCUIT:(SEE A1A1A1U1 REPL) *****ATTACHING PARTS*****						
-34	211-0008-00			1	..SCREW,MACHINE:4-40 X 0.250,PNH,STL,CD P *****END ATTACHING PARTS*****					83385	OBD
-35	----			2	..TERM,FEEDTHRU:(SEE A1A1A1J25,J28 REPL)						
-36	131-0787-00			2	..CONTACT,ELEC:0.64 INCH LONG					22526	47359
-37	352-0425-00			4	..FUSEHOLDER:PLASTIC					80009	352-0425-00

REPLACEABLE MECHANICAL PARTS

Fig. & Index No.	Tektronix Part No.	Serial/Model No. Eff	Dscont	Qty	1	2	3	4	5	Name & Description	Mfr Code	Mfr Part Number
3-	----			1						..CKT BOARD ASSY:STD REG(SEE A1A2 REPL)(ATTACHING PARTS).....		
-38	212-0023-00			2						..SCREW,MACHINE:8-32 X 0.375,PNH,STL CD PL(END ATTACHING PARTS).....	83385	OBD
-39	----			-						..CKT BOARD ASSY INCLUDES: ..TRANSISTOR:(SEE A1A2Q382,Q482,Q682, ..AND Q782 REPL)(ATTACHING PARTS).....		
-40	211-0097-00			4						..SCREW,MACHINE:4-40 X 0.312 INCH,PNH STL	83385	OBD
-41	210-1171-00			4						..WSHR,SHOULDERED:0.116 ID X 0.138 INCH OD(END ATTACHING PARTS).....	52905	A7148516P2
-42	342-0203-00			4						..INSULATOR,PLATE:XSTR,0.675 X 0.625 X 0.0	18722	DF103C
-43	----			1						..CKT BOARD ASSY:(SEE A1A2A2 REPL)(ATTACHING PARTS).....		
-44	211-0008-00			7						..SCREW,MACHINE:4-40 X 0.250,PNH,STL,CD PL(END ATTACHING PARTS).....	83385	OBD
-45	344-0154-00			8						..CLIP,ELECTRICAL:FUSE,CKT BD MT	80009	344-0154-00
-46	334-2151-00			1						..MARKER,IDENT:MKD DANGER 365 V	80009	334-2151-00
-47	131-0589-00			27						..TERMINAL,PIN:0.46 L X 0.025 SQ	22526	48283-029
-48	136-0514-00			4						..SKT,PL-IN ELEC:MICROCIRCUIT,8 DIP	73803	CS9002-8
-49	131-2264-00			1						..CONN,RCPT,ELEC:CKT BD,10 CONTACT,R ANGL	80009	131-2264-00
-50	----			1						..TRANSISTOR:(SEE A1A2A2Q741 REPL)(ATTACHING PARTS).....		
-51	211-0097-00			1						..SCREW,MACHINE:4-40 X 0.312 INCH,PNH STL	83385	OBD
-52	210-0586-00			1						..NUT,PL,ASSEM WA:4-40 X 0.25,STL(END ATTACHING PARTS).....	83385	OBD
-53	211-0001-00			2						..SCREW,MACHINE:2-56 X 0.25 INCH,PNH STL	87308	OBD
-54	342-0426-00			1						..INSULATOR,FILM:HEAT SINK,PLASTIC	80009	342-0426-00
-55	342-0424-00			1						..INSULATOR,FILM:HEAT SINK,PLASTIC	55285	OBD
-56	385-0012-00			4						..SPACER,POST:0.312 OD,0.562 L W/8-32 THD	80009	385-0012-00
-57	175-2499-00			1						..CA ASSY,SP,ELEC:2,22 AWG,8.5 L	80009	175-2499-00
-57.1	131-1815-00			2						..CONTACT,ELEC:22-30 AWG,FEMALE,BRASS	27264	08-56-0110
-58	131-0948-00			2						..CONTACT,ELEC:CONNECTOR,BRASS TIN PL	27264	02-09-1103
-58	204-0826-00			1						..CONN BODY,RCPT:2 CONT,FEMALE	27264	03-09-1021
-59	150-0035-00	B022742		1						..LAMP,GLOW:90V,0.3MA,AID-T,WIRE LD	000LI	JH005/3011JA
-59	204-0678-00			1						..CONN BODY,PL,EL:FOR 3 FEMALE CONTACTS	27264	10-17-2032
-60	----			1						..CKT BOARD ASSY:(SEE A1A2A1 REPL)(ATTACHING PARTS).....		
-61	211-0008-00			6						..SCREW,MACHINE:4-40 X 0.250,PNH,STL,CD PL(END ATTACHING PARTS).....	83385	OBD
-62	361-0909-00			1						..SPACER,PLATE:0.562 X 1.3 X 1.25 AL(ATTACHING PARTS).....	80009	361-0909-00
-63	211-0008-00			2						..SCREW,MACHINE:4-40 X 0.250,PNH,STL,CD P(END ATTACHING PARTS).....	83385	OBD
-64	361-0908-00			1						..SPACER,PLATE:0.562 X 2.4 X 1.0 AL(ATTACHING PARTS).....	80009	361-0908-00
-65	211-0008-00			2						..SCREW,MACHINE:4-40 X 0.250,PNH,STL,CD P(END ATTACHING PARTS).....	83385	OBD
-66	342-0425-00			1						..INSULATOR,FILM:TRANSISTOR,PLASTIC	80009	342-0425-00
-67	386-3928-00			1						..SUPPORT,XSTR:(ATTACHING PARTS).....	80009	386-3928-00
-68	211-0008-00			2						..SCREW,MACHINE:4-40 X 0.250,PNH,STL,CD P(END ATTACHING PARTS).....	83385	OBD
-69	342-0389-00			2						..INSULATOR,PLATE:TRANSISTOR,PLASTIC	80009	342-0389-00
-70	----			1						..CONN,RCPT,ELEC:CKT BD,10 CONTACT,R ANGL		
-71	136-0252-01	B010100	B022741	9						..CONTACT,ELEC:0.178 INCH LONG	00779	1-332095-2
-71	136-0252-07	B022742		9						..SOCKET,PIN CONN:W/O DIMPLE	22526	75060-012
-72	136-0269-02			4						..SKT,PL-IN ELEC:MICROCIRCUIT,14 DIP,LOW	73803	CS9002-14
-73	----			2						..DIODE:(SEE A1A2A1CR371,CR381 REPL)(ATTACHING PARTS).....		
	210-0224-00	B021519		2						..TERMINAL,LUG:0.20 ID X 0.344 OD,SE,BRS	86928	A373-148-1
	210-0010-00	B021519		2						..WASHER,LOCK:INT,0.20 ID X 0.376" OD,STL(END ATTACHING PARTS).....	78189	1210-00-00-0541C

REPLACEABLE MECHANICAL PARTS

Fig. & Index No.	Tektronix Part No.	Serial/Model No.		Qty	1	2	3	4	5	Name & Description	Mfr	
		Eff	Dscont								Code	Mfr Part Number
3-74	346-0128-00			1						...STRAP,TIE DOWN:0.1W X 8.0" LONG,NYLON	06383	PLT2M
-75	131-2182-00			2						...TERM. SET,PIN:1 X 5,0.156 SPACING,RTANG	27264	09-47-1052
	175-2436-00			1						...CA ASSY,SP,ELEC:2,26 AWG,2,18 AWG,7.25	80009	175-2436-00
-76	175-0072-00			AR						...CABLE,RF:2 CONDUCTOR	80009	175-0072-00
-76.1	354-0538-00	B021305		1						...PACKING,PREFMD:0.119 ID X 0.125" OD,NPR	07322	8006-366Y
-77	-----			1						...RES,FXD,WW:(SEE A1A2A1R1003 REPL)		
-78	343-0549-00			1						...STRAP,TIEDOWN:0.091 W X 3.62 INCH LONG	06383	PLT1M
-79	441-1457-00			1						..CHASSIS,CKT BD:	80009	441-1457-00

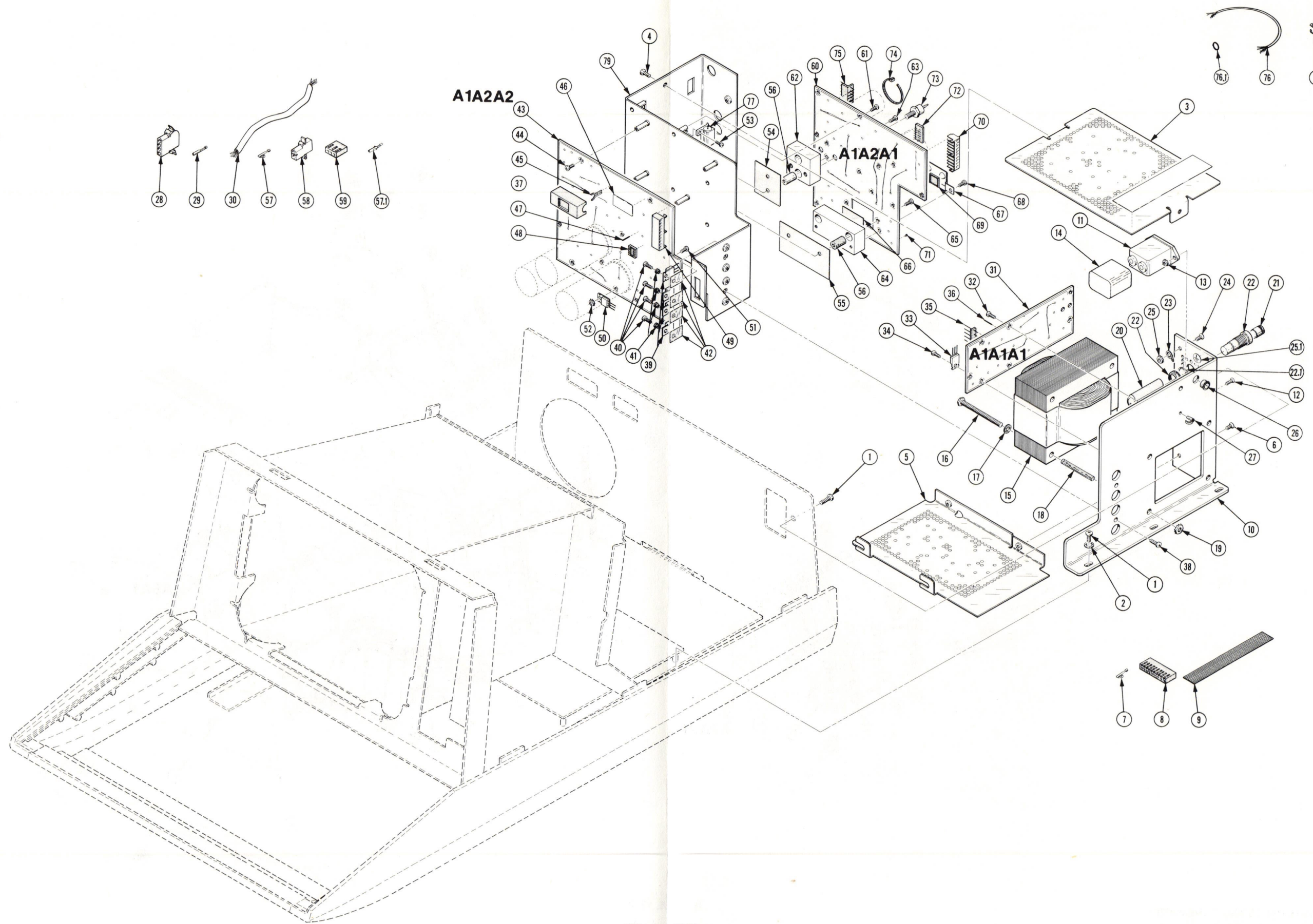

REV JUL 1982

4052/4052A PARTS AND SCHEMATICS

FIG. 3 POWER SUPPLY

FIG. 4 TAPE DRIVE ASSY

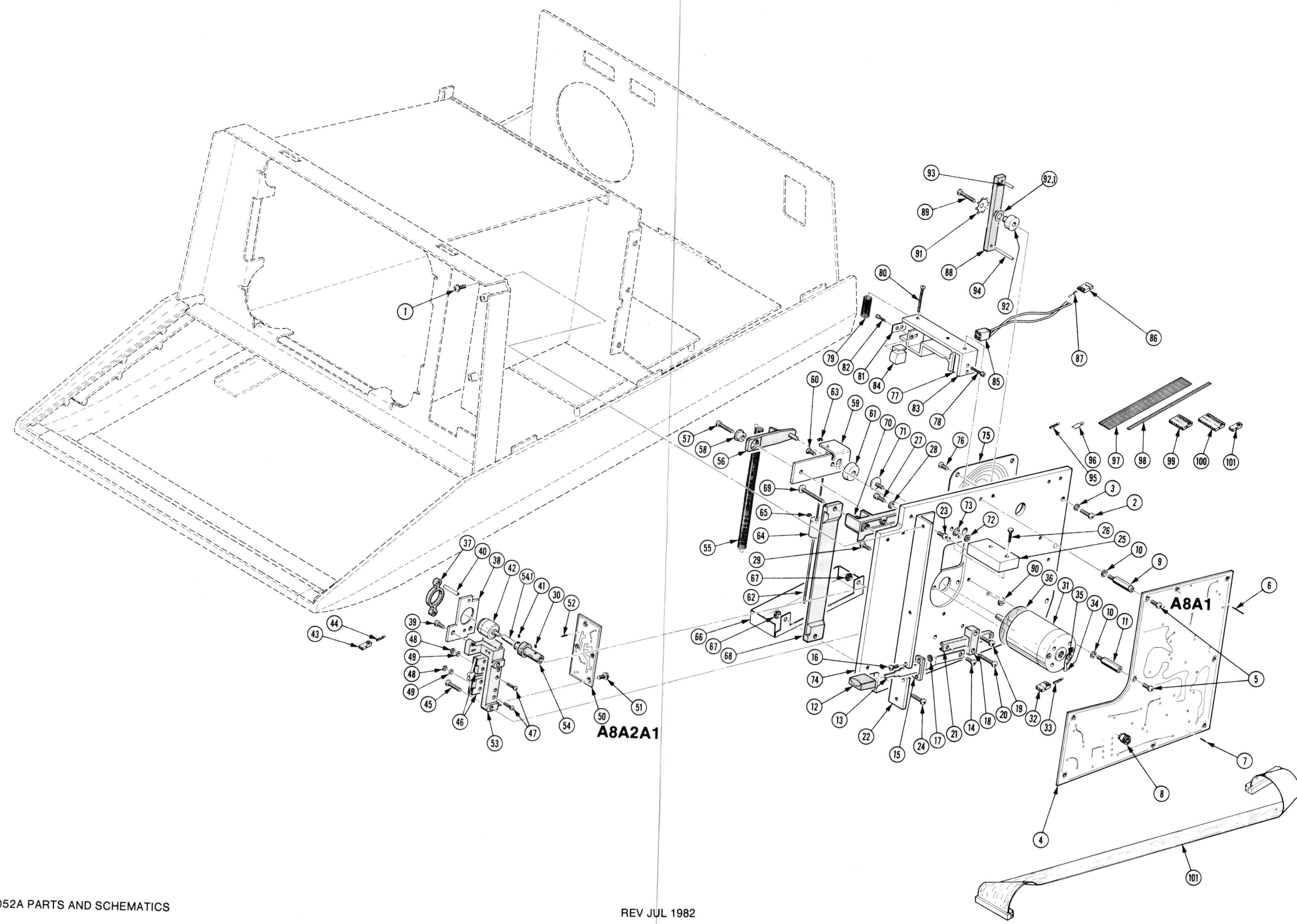

REPLACEABLE MECHANICAL PARTS

Fig. & Index No.	Tektronix Part No.	Serial/Model No. Eff	Dscont	Qty	1	2	3	4	5	Name & Description	Mfr Code	Mfr Part Number
4-	-----			1						DRIVE,MAG TAPE:(SEE A8 REPL) ***** (ATTACHING PARTS)*****		
-1	211-0534-00			2						SCR,ASSEM,WSHR:6-32 X 0.312 INCH,PNH STL	83385	OBD
-2	211-0551-00			3						SCREW,MACHINE:6-32 X 0.562 INCH,PNH STL	83385	OBD
-3	210-0006-00			3						WASHER,LOCK:#6 INTL,0.018 THK,STL CD PL ***** (END ATTACHING PARTS)*****	78189	1206-00-00-0541C
-4	-----			1						CKT BOARD ASSY:TAPE DRIVER(SEE A8A1 REPL) ***** (ATTACHING PARTS)*****		
-5	211-0507-00			8						SCREW,MACHINE:6-32 X 0.312 INCH,PNH STL ***** (END ATTACHING PARTS)*****	83385	OBD
-6	131-0589-00			12						CKT BOARD ASSY INCLUDES: ..TERMINAL,PIN:0.46 L X 0.025 SQ	22526	48283-029
-7	131-0608-00			60						..TERMINAL,PIN:0.365 L X 0.025 PH BRZ GOLD	22526	47357
-8	136-0237-00			2						..SOCKET,PLUG-IN:8 CONTACT,ROUND	71785	133-98-12-062
-9	129-0539-00			7						.POST,ELEC-MECH:6-32 THD EXT/INT,1.250 L	80009	129-0539-00
-10	210-0055-00			8						.WASHER,LOCK:SPLIT,0.145 ID X 0.253 OD,S	83385	OBD
-11	129-0295-00			1						.SPACER,POST:0.250 HEX X 0.894 INCH L,AL	80009	129-0295-00
-12	366-1629-01			1						.PUSH BUTTON:GRAY,EJECT	80009	366-1629-01
-13	214-2316-00			1						.LVR,CRTG EJECT:4.875 L,ALUMINUM ***** (ATTACHING PARTS)*****	80009	214-2316-00
-14	213-0054-00			1						.SCR,TPG,THD FOR:6-32 X 0.312 INCH,PNH STL ***** (END ATTACHING PARTS)*****	93907	OBD
-15	351-0455-00			1						.GUIDE,LEVER:EJECT ***** (ATTACHING PARTS)*****	80009	351-0455-00
-16	211-0012-00			2						.SCREW,MACHINE:4-40 X 0.375,PNH STL CD PL	83385	OBD
-17	210-0586-00			2						.NUT,PL,ASSEM WA:4-40 X 0.25,STL ***** (END ATTACHING PARTS)*****	83385	OBD
-18	391-0139-00			2						.BLOCK,GUIDE:CARTRIDGE EJEC ***** (ATTACHING PARTS)*****	80009	391-0139-00
-19	211-0513-00			2						.SCREW,MACHINE:6-32 X 0.625 INCH,PNH STL	83385	OBD
-20	211-0516-00			2						.SCREW,MACHINE:6-32 X 0.875 INCH,PNH STL ***** (END ATTACHING PARTS)*****	83385	OBD
-21	381-0365-00			2						.BAR,CRTG EJECT:DEL RIN	80009	381-0365-00
-22	407-1697-00			1						.BRACKET,ANGLE:TAPE DECK,ALUMINUM ***** (ATTACHING PARTS)*****	80009	407-1697-00
-23	211-0510-00			1						.SCREW,MACHINE:6-32 X 0.375,PNH,STL,CD PL	83385	OBD
-24	211-0513-00			1						.SCREW,MACHINE:6-32 X 0.625 INCH,PNH STL ***** (END ATTACHING PARTS)*****	83385	OBD
-25	391-0144-01			1						.BLOCK,SUPPORT:HEAD ALIGNMENT ***** (ATTACHING PARTS)*****	80009	391-0144-01
-26	211-0588-00			2						.SCREW,MACHINE:6-32 X 0.75 INCH,HEX.HD STL	83385	OBD
-27	211-0564-00			2						.SCREW,CAP,SCH:6-32 X 0.375" L HEX	80009	211-0564-00
-28	210-0803-00			2						.WASHER,FLAT:0.15 ID X 0.032 THK,STL CD ***** (END ATTACHING PARTS)*****	12327	OBD
	-----			1						.MOTOR,DC:(SEE A8B1092 REPL) ***** (ATTACHING PARTS)*****		
-29	211-0507-00			2						.SCREW,MACHINE:6-32 X 0.312 INCH,PNH STL	83385	OBD
-30	213-0228-01			1						.SETSCREW:6-32 X 0.125,STL,CD PL,HEX ***** (END ATTACHING PARTS)*****	000CY	OBD
	-----			-						.MOTOR ASSY INCLUDES:		
-31	147-0046-00			1						.MOTOR,DC:TAPE DRIVE,12V	98938	9213
-32	352-0161-05			1						..CONN BODY,PL,EL:3 WIRE GREEN	80009	352-0161-05
-33	131-0707-00			3						..CONNECTOR,TERM:22-26 AWG,BRS & CU BE GOL	22526	47439
-34	210-0203-00			1						..TERMINAL,LUG:SE #6 ***** (ATTACHING PARTS)*****	78189	2103-06-00-2520N
-35	213-0124-00			1						..SCR,TPG,THD FOR:6-20 X 0.250 INCH,PNH ST ***** (END ATTACHING PARTS)*****	83385	OBD
-36	361-0747-00			1						.SPACER,PLATE:0.562 ID X 0.02 THK	80009	361-0747-00
-37	352-0424-00			1						.HOLDER,TACH:SILCONE RUBBER	80009	352-0424-00
-38	386-3369-01			1						.PLATE,TACH: ***** (ATTACHING PARTS)*****	80009	386-3369-01
-39	211-0507-00			2						.SCREW,MACHINE:6-32 X 0.312 INCH,PNH STL ***** (END ATTACHING PARTS)*****	83385	OBD

REPLACEABLE MECHANICAL PARTS

Fig. & Index No.	Tektronix Part No.	Serial/Model No. Eff	Dscont	Qty	1 2 3 4 5	Name & Description	Mfr Code	Mfr Part Number
4-40	214-1474-00			2		.PIN,SPRING:0.75 L X 0.135 OD,CS BLACK	22599	59-028-125-0750
	-----			1		.MOTOR,DC:(SEE A8B1090 REPL)(ATTACHING PARTS).....		
-41	213-0228-01			1		.SETSCREW:6-32 X 0.125,STL,CD PL,HEX(END ATTACHING PARTS).....	000CY	OBD
	-----			-		.MOTOR ASSY INCLUDES:		
-42	147-0045-00			1		..MOTOR,DC:6V,17,000 RPM	50778	16C14-207-9
-43	352-0169-04			1		..CONN BODY,PL,EL:2 WIRE YELLOW	80009	352-0169-04
-44	131-0707-00			2		..CONNECTOR,TERM:22-26 AWG,BRS & CU BE GOL	22526	47439
	-----			1		.CKT BOARD ASSY:STATUS W/MICRO SW		
	-----			1		(SEE A8A2 REPL)(ATTACHING PARTS).....		
-45	211-0513-00			2		.SCREW,MACHINE:6-32 X 0.625 INCH,PNH STL(END ATTACHING PARTS).....	83385	OBD
	-----			-		.CKT BOARD ASSY INCLUDES:		
-46	-----			2		..SWITCH,PUSH:(SEE A8A2S1,S2 REPL)(ATTACHING PARTS).....		
-47	211-0034-00			4		..SCREW,MACHINE:2-56 X 0.50 INCH,PNH	83385	OBD
-48	210-0405-00			4		..NUT,PLAIN,HEX.:2-56 X 0.188 INCH,BRS	73743	12157-50
-49	210-0001-00			4		..WASHER,LOCK:INTL,0.092 ID X 0.18"OD,ST(END ATTACHING PARTS).....	78189	1202-00-00-0541C
-50	-----			1		..CKT BOARD ASSY:(SEE A8A2A1 REPL)(ATTACHING PARTS).....		
-51	211-0601-00			2		..SCR,ASSEM WSHR:6-32 X 0.312,DOUBLE SEMS(END ATTACHING PARTS).....	83385	OBD
	-----			-		.CKT BOARD ASSY INCLUDES:		
-52	131-0608-00			8		...TERMINAL,PIN:0.365 L X 0.025 PH BRZ GOL	22526	47357
-53	-----			1		..BRKT,SENSOR MTG:POLYCARBONATE		
-54	401-0342-01	B010100	B024747	1		.HUB,TAPE DRIVE:W/0.645 DIA HYPALON WHEEL	80009	401-0342-01
	401-0342-04	B024748		1		.HUB,TAPE DRIVE:W/0.645 DIA HYPALON WHEEL	80009	401-0342-04
-54.1	214-2419-00			1		.PIN,SPRING:0.5 L X 0.188 OD,AL	80009	214-2419-00
-55	214-2261-00			1		.SPRING,HLCPS:0.035 DIA,5.5 L MUSIC WIRE	80009	214-2261-00
-56	214-2264-00			2		.ARM,DETENT:TAPE POSITIONING(ATTACHING PARTS).....	80009	214-2264-00
-57	211-0514-00			2		.SCREW,MACHINE:6-32 X 0.750 INCH,PNH STL	83385	OBD
-58	343-0551-00			2		.RTNR,DETENT ARM:0.14 ID X 0.373 OD,AL(END ATTACHING PARTS).....	80009	343-0551-00
-59	351-0451-00			1		.GUIDE,TAPE CRTG:TOP LEFT(ATTACHING PARTS).....	80009	351-0451-00
-60	211-0522-00			1		.SCREW,MACHINE:6-32 X 0.625 FLH,100 DEG ST(END ATTACHING PARTS).....	83385	OBD
	351-0462-00			1		.GUIDE,TAPE CRTG:TOP RIGHT(ATTACHING PARTS).....	80009	351-0462-00
	211-0522-00			1		.SCREW,MACHINE:6-32 X 0.625 FLH,100 DEG ST(END ATTACHING PARTS).....	83385	OBD
-61	214-2263-00			2		.WHEEL,DETENT:0.187 ID X 0.6 OD,SST	80009	214-2263-00
-62	384-1383-00			1		.SHAFT,HOLDDOWN:0.093 DIA X 7.66 L,STL(ATTACHING PARTS).....	80009	384-1383-00
-63	354-0350-00			2		.RING,RETAINING:0.073"FREE ID X 0.015",ST(END ATTACHING PARTS).....	79136	5133-9MD
-64	401-0349-00			1		.ROLLER,HOLDDOWN:0.50 DIA X 0.75 L,NYLON(ATTACHING PARTS).....	80009	401-0349-00
-65	354-0554-00			2		.RING,RETAINING:EXT LUG GRIPPING,0.094 D(END ATTACHING PARTS).....	79136	G5555-9
-66	337-2260-00			1		.SHIELD:TRAY,SAFETY(ATTACHING PARTS).....	80009	337-2260-00
-67	210-0457-00			2		.NUT,PL,ASSEM WA:6-32 X 0.312,STL CD PL(END ATTACHING PARTS).....	83385	OBD
-68	351-0459-00	B010100	B023310	1		.GUIDE,TAPE CRTG:ENTRANCE	80009	351-0459-00
	351-0629-00	B023311		1		.GUIDE,TAPE CRTG:ENTRANCE(ATTACHING PARTS).....	80009	351-0629-00
-69	211-0545-00			2		.SCREW,MACHINE:6-32 X 1.250 INCH,TRH STL(END ATTACHING PARTS).....	83385	OBD

REPLACEABLE MECHANICAL PARTS

Fig. & Index No.	Tektronix Part No.	Serial/Model No.		Qty	Name & Description					Mfr Code	Mfr Part Number
		Eff	Dscont		1	2	3	4	5		
4-70	351-0454-00			1						80009	351-0454-00
	351-0453-00			1						80009	351-0453-00
-71	361-0781-00			2						80009	361-0781-00
											***** (ATTACHING PARTS) *****
-72	210-0407-00			2						73743	3038-0228-402
-73	210-0006-00			2						78189	1206-00-00-0541C
											***** (END ATTACHING PARTS) *****
-74	386-3368-00	B010100	B021666	1						80009	386-3368-00
	386-3368-01	B021667		1						80009	386-3368-01
-75	-----			1							..LOUDSPEAKER,PM:(SEE A8LS60 REPL) ***** (ATTACHING PARTS) *****
-76	211-0507-00			4						83385	OBD
											***** (END ATTACHING PARTS) *****
-77	386-3554-00			1						80009	386-3554-00
											***** (ATTACHING PARTS) *****
-78	211-0164-00			1						83385	OBD
	211-0093-00			1						000BK	OBD
											***** (END ATTACHING PARTS) *****
-79	214-2430-00			1						000AE	C36C
											***** (ATTACHING PARTS) *****
-80	211-0248-00			1						000AH	OBD
											***** (END ATTACHING PARTS) *****
-81	386-2823-00			1						80009	386-2823-00
											***** (ATTACHING PARTS) *****
-82	211-0206-00			2						000AH	OBD
											***** (END ATTACHING PARTS) *****
-83	352-0450-01			1						80009	352-0450-01
-84	-----			1							..HEAD,SRR:(SEE A8PU1001 REPL)
	119-0421-03			1						80009	119-0421-03
-85	119-0421-01			1						11983	139077
-86	352-0161-08			1						80009	352-0161-08
	352-0161-09			1						80009	352-0161-09
-87	131-0707-00			6						22526	47439
-88	214-2319-00			1						80009	214-2319-00
											***** (ATTACHING PARTS) *****
-89	211-0517-00			1						83385	OBD
-90	210-0457-00			1						83385	OBD
-91	210-1252-00	B010100	B021666	1						78189	3522-06-01
	210-0803-00	B021667		1						12327	OBD
-92	214-2320-00			1						80009	214-2320-00
-92.1	210-0992-00	B021667		1						80009	210-0992-00
											***** (END ATTACHING PARTS) *****
-93	214-2351-00			1						22599	52-022-094-0375
-94	214-1534-00			1						22599	59-022-094-1250
	198-0725-00			1						80009	198-0725-00
-95	131-0707-00			20						22526	47439
-96	131-2512-00			2						00779	62138-1
-97	175-0832-00			AR						08261	SS-0926(1061)0C
-98	175-0863-00			AR						08261	SS-0222-7(1061)
-99	352-0165-00			1						80009	352-0165-00
-100	352-0167-07			1						80009	352-0167-07
-101	352-0169-00			1						80009	352-0169-00
	352-0169-01			1						80009	352-0169-01
	175-2123-00			1						80009	175-2123-00

REPLACEABLE MECHANICAL PARTS

Fig. & Index No.	Tektronix Part No.	Serial/Model No. Eff Dscnt	Qty	1 2 3 4 5	Name & Description	Mfr Code	Mfr Part Number
5-1	407-0997-00		2		BRACKET,ANGLE:IMPLOSION SHLD RTNR,AL ***** (ATTACHING PARTS) *****	80009	407-0997-00
-2	211-0008-00		4		SCREW,MACHINE:4-40 X 0.250,PNH,STL,CD PL ***** (END ATTACHING PARTS) *****	83385	OBD
-3	253-0056-00		AR		CUSHION:POLYURETHANE FOAM,PRESSURE	04963	4116
-4	337-1482-00		1		FILTER,LT,CRT:	80009	337-1482-00
-5	426-0834-01		1		FR,IMPLOSION SH: ***** (ATTACHING PARTS) *****	80009	426-0834-01
-6	212-0553-00		4		SCREW,MACHINE:10-32 X 1.50 INCH,PNH STL	83385	OBD
-7	361-0541-00		4		SPACER,SLEEVE:0.50 OD X 0.976 INCH LONG ***** (END ATTACHING PARTS) *****	80009	361-0541-00
-8	131-1385-00		4		CONTACT,ELEC:GROUNDING	80009	131-1385-00
-8.1	210-0632-00		8		EYELET,METALLIC:0.089 OD X 0.125" LONG,BRS	01881	3168
-9	378-0064-00		1		FILTER,LIGHT:6.276 X 1.0,0.06 R ACRYLIC ***** (ATTACHING PARTS) *****	80009	378-0064-00
-10	211-0017-00		2		SCREW,MACHINE:4-40 X 0.375 INCH,PNH STL ***** (END ATTACHING PARTS) *****	83385	OBD
-11	-----		1		CKT BOARD ASSY:INDICATOR LIGHT(SEE A9 REPL		
-12	131-0608-00		8		.TERMINAL,PIN:0.365 L X 0.025 PH BRZ GOLD	22526	47357
-13	337-2235-00		2		.SHIELD,LIGHT:CKT CD MT,1.0 X 0.355 INCH	80009	337-2235-00
-14	361-0751-00		2		.SPACER,SLEEVE:0.156 ID X 0.312 OD X 0.493	80009	361-0751-00
-15	-----		1		ELECTRON TUBE:CRT(SEE CHASSIS V1 REPL)		
-16	354-0316-01		1		.RING,CRT MTG:NEOPRENE	80009	354-0316-01
-16.1	344-0294-00		1		CLIP,GROUND:BRS SATIN NICKEL PL	80009	344-0294-00
-16.2	343-0628-00		1		RETAINER,CLIP:GROUNDING,AL	80009	343-0628-00
-16.3	211-0008-00		1		SCREW,MACHINE:4-40 X 0.250,PNH,STL,CD PL	83385	OBD
-17	386-3367-00		1		SUPPORT,CRT:FRONT ***** (ATTACHING PARTS) *****	80009	386-3367-00
-18	212-0004-00		2		SCREW,MACHINE:8-32 X 0.312 INCH,PNH STL	83385	OBD
-19	210-0008-00		2		WASHER,LOCK:INTL,0.172 ID X 0.331" OD,S ***** (END ATTACHING PARTS) *****	78189	1208-00-00-0541C
-20	129-0569-00		2		POST,ELEC-MECH:0.543 L,W/4-40 THD,AL	80009	129-0569-00
-21	343-0298-00		1		CLAMP,LOOP:PLASTIC,W/ADHESIVE BACK	95987	HPC25
-22	386-3420-00		1		STIFFENER,CHAS:DISPLAY ***** (ATTACHING PARTS) *****	80009	386-3420-00
-23	211-0097-00		3		SCREW,MACHINE:4-40 X 0.312 INCH,PNH STL ***** (END ATTACHING PARTS) *****	83385	OBD
-24	334-1379-00		1		LABEL:CRT,ADHESIVE BACK	80009	334-1379-00
-25	348-0115-01		1		GROMMET,PLASTIC:U-SHAPED	80009	348-0115-01
-26	343-0006-00		1		CLAMP,LOOP:0.50 INCH DIAMETER,PLSTC ***** (ATTACHING PARTS) *****	95987	1-2-6B
-27	211-0014-00		1		SCREW,MACHINE:4-40 X 0.50 INCH,PNH STL	83385	OBD
-28	210-0994-00		1		WASHER,FLAT:0.125 ID X 0.25" OD,STL	86928	5702-201-20
-29	210-0863-00		1		WSHR,LOOP CLAMP:0.187 ID U/W 0.5 W CLP,STL ***** (END ATTACHING PARTS) *****	95987	C191
-30	348-0013-00		4		FOOT,CABINET:BLACK RUBBER	70485	1561
-31	358-0566-00		1		.INSULATOR,BSHG:0.625 ID X 0.406 THK,NYLON	28520	SB-812-10
-32	337-1519-00		1		SHLD,ELCTR N TUB:FRONT ***** (ATTACHING PARTS) *****	80009	337-1519-00
-33	211-0590-00		4		SCREW,MACHINE:6-32 X 0.250,PNH,BRS,CD PL ***** (END ATTACHING PARTS) *****	83385	OBD
-34	343-0089-00		2		CLAMP,LOOP:LARGE	80009	343-0089-00
-35	343-0213-00		2		CLAMP,LOOP:0.2 ID,PLASTIC	80009	343-0213-00
-36	255-0334-00		AR		PLASTIC CHANNEL:12.75 X 0.175 X 0.155,NYL	11897	122-37-2500
-37	386-3349-01		1		SUPPORT,CRT:CENTER ***** (ATTACHING PARTS) *****	80009	386-3349-01
-38	212-0004-00		2		SCREW,MACHINE:8-32 X 0.312 INCH,PNH STL	83385	OBD
-39	210-0008-00		2		WASHER,LOCK:INTL,0.172 ID X 0.331" OD,S ***** (END ATTACHING PARTS) *****	78189	1208-00-00-0541C
-40	407-1749-00		1		BRACKET,YOKE:ALUMINUM ***** (ATTACHING PARTS) *****	80009	407-1749-00
-41	211-0581-00		2		SCREW,MACHINE:6-32 X 0.375 INCH,TRH STL	83385	OBD
-42	210-0006-00		2		WASHER,LOCK:#6 INTL,0.018 THK,STL CD PL ***** (END ATTACHING PARTS) *****	78189	1206-00-00-0541C
-42.1	358-0561-00		1		BUSHING,SLEEVE:1.15 ID X 2.0 L,SI,1.2 OD	80009	358-0561-00

REPLACEABLE MECHANICAL PARTS

Fig. & Index No.	Tektronix Part No.	Serial/Model No. Eff	Dscont	Qty	1	2	3	4	5	Name & Description	Mfr Code	Mfr Part Number
5-43	119-0745-00			1						COIL,TUBE DEFL:	80009	119-0745-00
-44	337-2263-00			1						SHLD,ELECTRON T:REAR	80009	337-2263-00
										*****ATTACHING PARTS*****		
-45	210-0458-00			2						NUT,PL,ASSEM WA:8-32 X 0.344 INCH,STL	83385	OBD
										*****END ATTACHING PARTS*****		
	198-2604-00			1						WIRE SET,ELEC:	80009	198-2604-00
-46	131-0621-00			4						.CONNECTOR,TERM:22-26 AWG,BRS & CU BE GOLD	22526	46231
-47	343-0549-00			2						.STRAP,TIEDOWN:0.091 W X 3.62 INCH LONG	06383	PLT1M
-48	352-0198-01			1						.HLDR,TERM CONN:2 WIRE BROWN	80009	352-0198-01
-49	380-0332-01			1						HSG,FAN GUARD:ABS	80009	380-0332-01
										*****ATTACHING PARTS*****		
-50	211-0514-00			4						SCREW,MACHINE:6-32 X 0.750 INCH,PNH STL	83385	OBD
-51	210-0457-00			4						NUT,PL,ASSEM WA:6-32 X 0.312,STL CD PL	83385	OBD
										*****END ATTACHING PARTS*****		
-52	200-2222-00			2						GUARD,FAN:	81041	6-182-033
										*****ATTACHING PARTS*****		
-53	211-0551-00			4						SCREW,MACHINE:6-32 X 0.562 INCH,PNH STL	83385	OBD
-54	210-0457-00			4						NUT,PL,ASSEM WA:6-32 X 0.312,STL CD PL	83385	OBD
										*****END ATTACHING PARTS*****		
-55	119-0721-00			1						FAN,VENTILATING:75 CFM,7W,115VAC,50/60HZ	80009	119-0721-00
	175-2501-00			1						CA ASSY,SP,ELEC:2,18 AWG,4.5 L	80009	175-2501-00
-56	131-0945-00			2						.CONTACT,ELEC:CONNECTOR,BRASS TIN PL	27264	02-09-2101
-57	131-0945-00			2						.CONTACT,ELEC:CONNECTOR,BRASS TIN PL	27264	02-09-2101
-58	204-0827-00			1						.CONN BODY,PLUG:2 CONT FEMALE	27264	03-09-2022
-59	175-2203-00			AR						.CABLE,SP,ELEC:2,18 AWG,W/VINYL JACKET	80009	175-2203-00
-60	175-2456-00			2						CA ASSY,SP,ELEC:34,28 AWG,2.0 L	22526	80564-001
-61	386-4052-00			1						SUPPORT,CKT BD:RIGHT	80009	386-4052-00
										*****ATTACHING PARTS*****		
-62	211-0514-00			5						SCREW,MACHINE:6-32 X 0.750 INCH,PNH STL	83385	OBD
-63	211-0538-00			8						SCREW,MACHINE:6-32 X 0.312"100 DEG,FLH ST	83385	OBD
										*****END ATTACHING PARTS*****		
-64	386-4053-00			1						SUPPORT,CKT BD:LEFT	80009	386-4053-00
										*****ATTACHING PARTS*****		
-64.1	211-0514-00			5						SCREW,MACHINE:6-32 X 0.750 INCH,PNH STL	83385	OBD
-64.2	211-0538-00			8						SCREW,MACHINE:6-32 X 0.312"100 DEG,FLH ST	83385	OBD
										*****END ATTACHING PARTS*****		
-65	-----			1						CKT BOARD ASSY:ALU(SEE A2 REPL)		
-66	136-0634-00	B010100	B024075	4						.SOCKET,PLUG-IN:20 LEAD DIP,CKT BD MTG	73803	CS9002-20
	136-0634-00	B024076		3						.SOCKET,PLUG-IN:20 LEAD DIP,CKT BD MTG	73803	CS9002-20
	136-0752-00	B024076		1						.SKT,PL-IN ELEK:MICROCIRCUIT,20 DIP	09922	DILB20P-108
-67	-----			50						.TERMINAL,PIN:(SEE A2J200,J203,J204,J205,		
	-----			-						J206,AND J207 REPL)		
-68	136-0578-00	B010100	B010502	7						.SKT,PL-IN ELEK:MICROCKT,24 PIN,LOW PROFIL	73803	C S9002-24
	136-0751-00	B010503		7						.SKT,PL-IN ELEK:MICROCKT,24 PIN	09922	DILB24P108
-69	136-0623-00			4						.SOCKET,PLUG-IN:40 DIP,LOW PROFILE	73803	CS9002-40
-70	129-0753-00			1						.SPACER,POST:0.413 L,W/6-32 THRU THD,BRS	80009	129-0753-00
										*****ATTACHING PARTS*****		
-71	211-0558-00	B010100	B010502	1						.SCREW,MACHINE:6-32 X 0.250 BDGH,NYL,SLOT	26365	921-1150-0014
	200-2486-00	B010503		1						.CAP.,INSULATING:0.187 OD,BLACK,VINYL	15819	.187-4 TRIMLINE
										*****END ATTACHING PARTS*****		
-72	361-0562-00			5						.SPACER,SLEEVE:0.156 ID X 0.25 OD X 0.375	80009	361-0562-00
-73	129-0750-00			2						.SPACER,POST:1.073 L,W/6-32 THD EA END,A	80009	129-0750-00
-74	136-0260-02	B010100	B024075	3						.SKT,PL-IN ELEK:MICROCIRCUIT,16 DIP,LOW CL	71785	133-51-92-008
	136-0729-00	B024076		3						.SKT,PL-IN ELEK:MICROCKT,16 CONTACT	09922	DILB16P-108T
-75	-----			2						.CONN,RCPT,ELEC:(SEE A2J201A,J201B REPL)		
-76	131-0993-00			1						.BUS,CONDUCTOR:2 WIRE BLACK	00779	850100-01
-77	-----			1						CKT BOARD ASSY:MCP(SEE A3 REPL)		
-78	-----			79						.TERMINAL,PIN:(SEE A3J264,J266,J268,		
	-----			-						J272,AND J276 REPL)		
-79	-----			1						.CONN,RCPT,ELEC:(SEE A3J20 REPL)		
-79.1	131-2448-00			1						.TERM SET,PIN:7 MALE CONTACTS	27264	09-61-1071
-80	361-0562-00			8						.SPACER,SLEEVE:0.156 ID X 0.25 OD X 0.375	80009	361-0562-00
-81	129-0753-00			2						.SPACER,POST:0.413 L,W/6-32 THRU THD,BRS	80009	129-0753-00
										*****ATTACHING PARTS*****		
-82	211-0558-00			2						.SCREW,MACHINE:6-32 X 0.250 BDGH,NYL,SLOT	26365	921-1150-0014
										*****END ATTACHING PARTS*****		

REPLACEABLE MECHANICAL PARTS

Fig. & Index No.	Tektronix Part No.	Serial/Model No. Eff	Dscont	Qty	1 2 3 4 5	Name & Description	Mfr Code	Mfr Part Number
5-83	-----			2		.CONN,RCPT,ELEC:(SEE A3J1 REPL)		
-84	-----			2		.CONNECTOR,RCPT.:(SEE A3J54,J55 REPL) *****ATTACHING PARTS*****		
-85	211-0159-00			4		.SCREW,MACHINE:2-56 X 0.375 INCH,PNH STL	87308	OBD
-86	210-0405-00			4		.NUT,PLAIN,HEX.:2-56 X 0.188 INCH,BRS *****END ATTACHING PARTS*****	73743	12157-50
-87	-----			1		CKT BOARD ASSY:MAS(SEE A4 REPL)		
-88	136-0634-00			2		.SOCKET,PLUG-IN:20 LEAD DIP,CKT BD MTG	73803	CS9002-20
-89	136-0260-02	B010100	B024075	19		.SKT,PL-IN ELEK:MICROCIRCUIT,16 DIP,LOW CL	71785	133-51-92-008
	136-0729-00	B024076		19		.SKT,PL-IN ELEK:MICROCKT,16 CONTACT	09922	DILB16P-108T
-90	131-0993-00			3		.BUS,CONDUCTOR:2 WIRE BLACK	00779	850100-01
-91	136-0694-00			2		.SKT,PL-IN ELEK:MICROCIRCUIT,28 CONTACT	73803	CS9002-28
-92	136-0578-00	B010100	B024075	8		.SKT,PL-IN ELEK:MICROCKT,24 PIN,LOW PROFIL	73803	C S9002-24
	136-0751-00	B024076		8		.SKT,PL-IN ELEK:MICROCKT,24 PIN	09922	DILB24P108
-93	129-0747-00			8		.SPACER POST:0.633 L,W/6-32 THRU THD,AL	80009	129-0747-00
-94	-----			4		.TERM. SET,PIN:(SEE A4J141 THRU A4J147 REP		
-94.1	131-0346-01			1		.CONN,RCPT,ELEC:24 CONTACT,FEMALE	71785	222-22-24-242
-95	129-0435-00			2		.SPACER,POST:0.625 L,W-6-32 THD THRU,BRS *****ATTACHING PARTS*****	80009	129-0435-00
-96	211-0558-00			2		.SCREW,MACHINE:6-32 X 0.250 BDGH,NYL,SLOT *****END ATTACHING PARTS*****	26365	921-1150-0014
-97	-----			1		.CONN,RCPT,ELEC:(SEE A4J101 REPL)		
-98	-----			2		.CONNECTOR,RCPT:(SEE A4J155 REPL) *****ATTACHING PARTS*****		
-99	211-0159-00			4		.SCREW,MACHINE:2-56 X 0.375 INCH,PNH STL	87308	OBD
-100	210-0405-00			4		.NUT,PLAIN,HEX.:2-56 X 0.188 INCH,BRS *****END ATTACHING PARTS*****	73743	12157-50
-101	-----			1		CKT BOARD ASSY:1/O(SEE A5 REPL)		
-102	-----			2		.CONN,RCPT,ELEC:(SEE A5P101A,P101B REPL)		
-103	131-0608-00			7		.TERMINAL,PIN:0.365 L X 0.025 PH BRZ GOLD	22526	47357
-104	136-0623-00			4		.SOCKET,PLUG-IN:40 DIP,LOW PROFILE	73803	CS9002-40
-105	129-0435-00			2		.SPACER,POST:0.625 L,W-6-32 THD THRU,BRS *****ATTACHING PARTS*****	80009	129-0435-00
-106	211-0558-00			2		.SCREW,MACHINE:6-32 X 0.250 BDGH,NYL,SLOT *****END ATTACHING PARTS*****	26365	921-1150-0014
-107	129-0747-00			6		.SPACER POST:0.633 L,W/6-32 THRU THD,AL	80009	129-0747-00
-108	-----			2		.CONNECTOR,RCPT:(SEE A5J2,J3 REPL) *****ATTACHING PARTS*****		
-109	211-0159-00			4		.SCREW,MACHINE:2-56 X 0.375 INCH,PNH STL	87308	OBD
-110	210-0405-00			4		.NUT,PLAIN,HEX.:2-56 X 0.188 INCH,BRS *****END ATTACHING PARTS*****	73743	12157-50
-111	361-0980-00			1		.SPACER,SLEEVE:0.640 L X 0.156 ID,BRASS CU	80009	361-0980-00
-112	-----			1		.CONN,RCPT,ELEC:(SEE A5J4 REPL)		
-113	211-0510-00			1		.SCREW,MACHINE:6-32 X 0.375,PNH,STL,CD PL	83385	OBD
-114	210-0006-00			1		.WASHER,LOCK:#6 INTL,0.018 THK,STL CD PL	78189	1206-00-00-0541C
-115	366-1522-00			1		KNOB:LINE VOLTAGE INDICATOR *****ATTACHING PARTS*****	80009	366-1522-00
-116	211-0507-00			1		SCREW,MACHINE:6-32 X 0.312 INCH,PNH STL *****END ATTACHING PARTS*****	83385	OBD
-117	136-0651-00			1		SKT,PL-IN ELEK:ANODE,7 CONTACT	80009	136-0651-00
-118	136-0271-00			1		.SOCKET,PLUG-IN:7 PIN	71785	111-01-10-012
-119	200-0811-00			1		.COVER,SKT TERM:0.81 OD X 0.849 L,PLASTIC	80009	200-0811-00
-120	352-0204-08			1		.HLDR,TERM CONN:8 WIRE,GRAY	80009	352-0204-08
-121	131-0621-00			7		.CONNECTOR,TERM:22-26 AWG,BRS & CU BE GOLD	22526	46231
-122	175-0830-00			AR		.WIRE,ELECTRICAL:7 WIRE RIBBON	08261	SS-0726-710610C

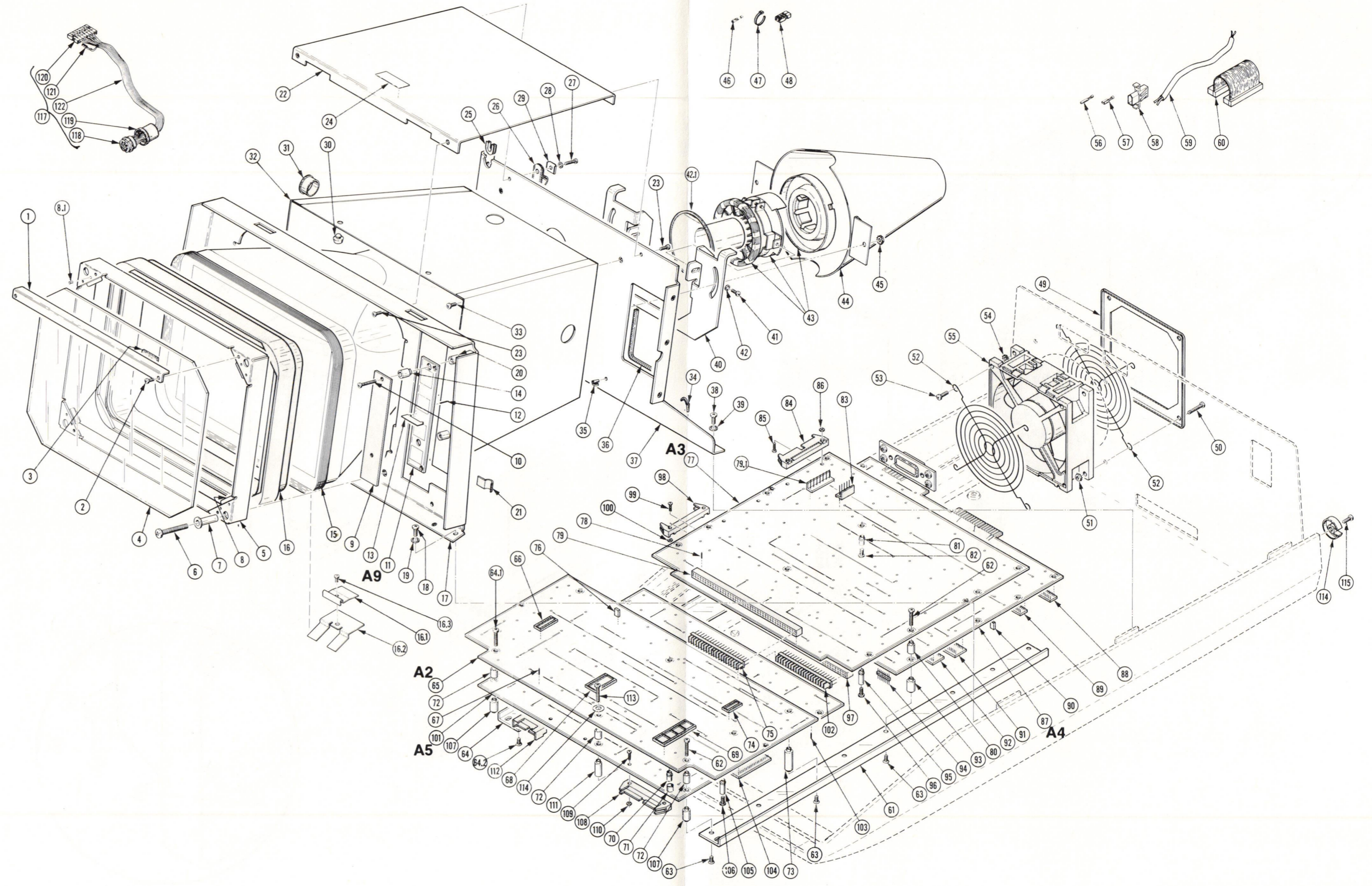

REV JUL 1982

4052/4052A PARTS AND SCHEMATICS

FIG. 5 CRT, FAN, AND RAIL ASSEMBLY

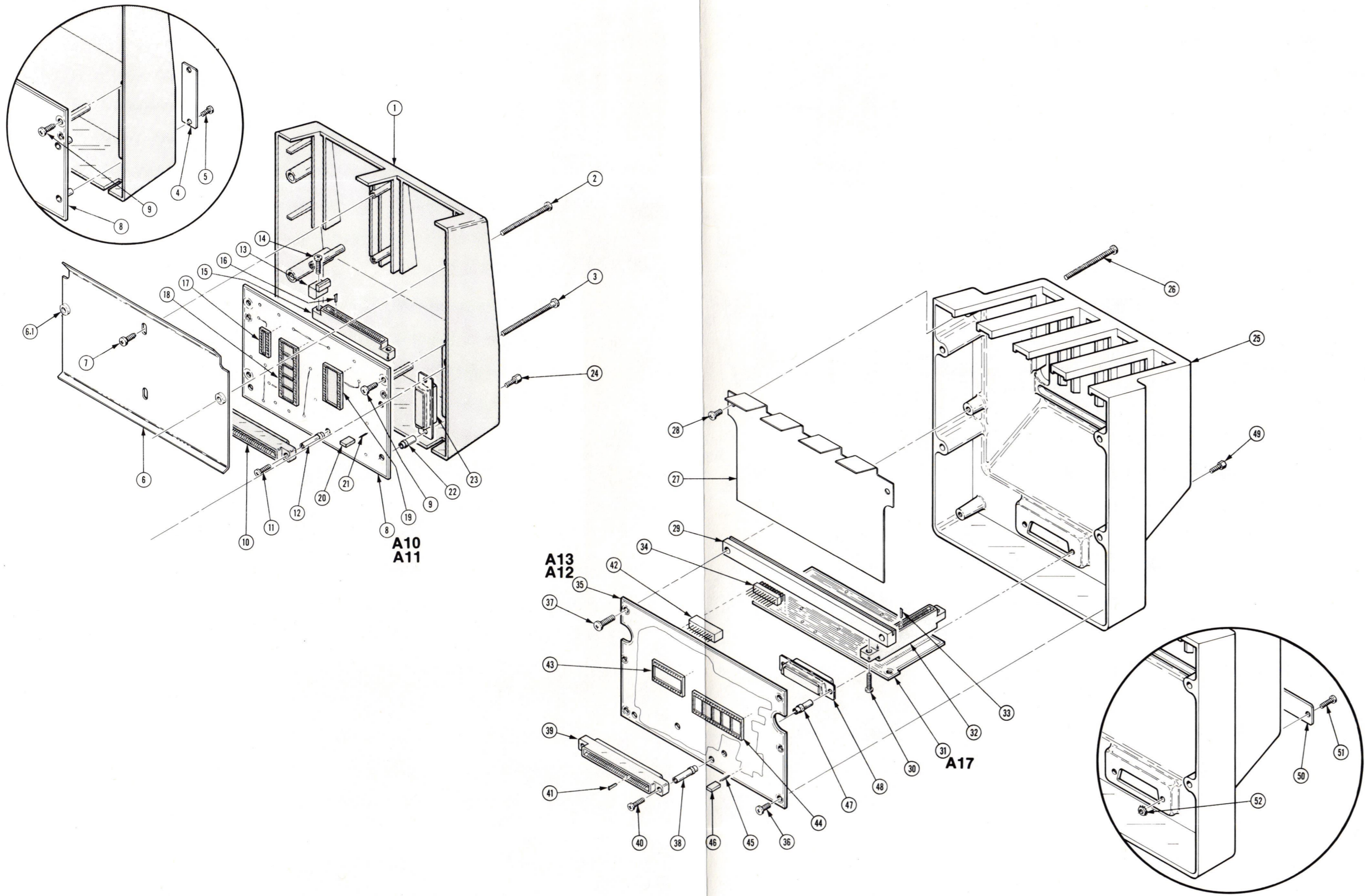

REPLACEABLE MECHANICAL PARTS

Fig. & Index No.	Tektronix Part No.	Serial/Model No.		Qty	1	2	3	4	5	Name & Description	Mfr	
		Eff	Dscont								Code	Mfr Part Number
6-1	200-1851-03			1						COVER,ROM PACK:PLASTIC,SILVER GRAY (STANDARD ONLY)	80009	200-1851-03
	200-1851-01	B010100	B022999	1						COVER,ROM PACK:PLASTIC,SILVER (OPTION 1 ONLY)	80009	200-1851-01
	200-1851-03	B023000		1						COVER,ROM PACK:PLASTIC,SILVER GRAY (OPTION 1 ONLY)	80009	200-1851-03
										*****ATTACHING PARTS*****		
-2	211-0530-00			2						SCREW,MACHINE:6-32 X 1.75 INCH,PNH STL	83385	OBD
-3	211-0623-00			2						SCREW,MACHINE:6-32 X 2.25 INCHES,PNH,STL *****END ATTACHING PARTS*****	83385	OBD
										*****ATTACHING PARTS*****		
-4	200-1887-00			1						.COVER,FIRMWARE:PLASTIC (STANDARD ONLY)	80009	200-1887-00
										*****ATTACHING PARTS*****		
-5	211-0008-00			2						.SCREW,MACHINE:4-40 X 0.250,PNH,STL,CD PL (STANDARD ONLY)	83385	OBD
										*****END ATTACHING PARTS*****		
-6	351-0452-01			1						.GUIDE,ROM PACK:ALUMINUM	80009	351-0452-01
-6.1	361-1012-00			2						.SPACER,SLEEVE:0.295 L X 0.188 ID,BRASS *****ATTACHING PARTS*****	80009	361-1012-00
										*****END ATTACHING PARTS*****		
-7	213-0054-00			2						.SCR,TPG,THD FOR:6-32 X 0.312 INCH,PNH STL *****END ATTACHING PARTS*****	93907	OBD
										*****ATTACHING PARTS*****		
-8				1						.CKT BOARD ASSY:FIRMWARE/COMM BACKPACK (SEE A10 AND A11 REPL)		
										*****ATTACHING PARTS*****		
-9	213-0054-00			3						.SCR,TPG,THD FOR:6-32 X 0.312 INCH,PNH STL *****END ATTACHING PARTS*****	93907	OBD
										*****ATTACHING PARTS*****		
										.CKT BOARD ASSY INCLUDES:		
-10				1						.CONN,RCPT,ELEC:(SEE A10,A11P5 REPL) *****ATTACHING PARTS*****		
										*****END ATTACHING PARTS*****		
-11	211-0198-00			2						.SCREW,MACHINE:4-40 X 0.438 PNH,STL,POZ *****END ATTACHING PARTS*****	77250	OBD
										*****ATTACHING PARTS*****		
-12	129-0248-00			2						.SPACER,POST:0.663 INCH LONG,BRS	80009	129-0248-00
-13	351-0500-00			4						.GUIDE,CKT CARD: *****ATTACHING PARTS*****	80009	351-0500-00
										*****END ATTACHING PARTS*****		
-14	211-0198-00			4						.SCREW,MACHINE:4-40 X 0.438 PNH,STL,POZ *****END ATTACHING PARTS*****	77250	OBD
										*****ATTACHING PARTS*****		
-15				2						.CONN,RCPT,ELEC:(SEE A10,A11J91,J92 REPL)		
-16	214-1458-00	B010100	B022499	3						.KEY,CONN PLZN:CKT BOARD	05574	091-0071-000
-17	136-0260-02			1						.SKT,PL-IN ELEK:MICROCIRCUIT,16 DIP,LOW C (OPTION 1 ONLY)	71785	133-51-92-008
										*****ATTACHING PARTS*****		
-18	136-0623-00			1						.SOCKET,PLUG-IN:40 DIP,LOW PROFILE (OPTION 1 ONLY)	73803	CS9002-40
										*****ATTACHING PARTS*****		
-19	136-0578-00			1						.SKT,PL-IN ELEK:MICROCKT,24 PIN,LOW PROFI (OPTION 1 ONLY)	73803	C S9002-24
										*****ATTACHING PARTS*****		
-20	131-0993-00			3						.BUS,CONDUCTOR:2 WIRE BLACK (OPTION 1 ONLY)	00779	850100-01
										*****ATTACHING PARTS*****		
-21	131-0608-00			9						.TERMINAL,PIN:0.365 L X 0.025 PH BRZ GOLD (OPTION 1 ONLY)	22526	47357
										*****ATTACHING PARTS*****		
-22	129-0112-00			2						.SPACER,POST:0.406 L FROM MT SEAT X 0.21 (OPTION 1 ONLY)	80009	129-0112-00
										*****ATTACHING PARTS*****		
-23				1						.CONN,RCPT,ELEC:(SEE A11J93 REPL) (OPTION 1 ONLY)		
										*****ATTACHING PARTS*****		
-24	131-0890-00			2						LOCK,CONNECTOR:4-40 X 0.312 L	71468	D 20418-2
	334-2788-01			1						OVERLAY,KYBD:MARKED DATA COMMUNICATION (OPTION 1 ONLY)	80009	334-2788-01
										*****ATTACHING PARTS*****		
	175-1778-01			1						CA ASSY,SP,ELEC:34,28 AWG,2.5 L (OPTION 1 ONLY)	80009	175-1778-01
										*****ATTACHING PARTS*****		
-24.1	129-0747-00			2						SPACER POST:0.633 L,W/6-32 THRU THD,AL	80009	129-0747-00

REPLACEABLE MECHANICAL PARTS

Fig. & Index No.	Tektronix Part No.	Serial/Model No. Eff	Dscont	Qty	1 2 3 4 5	Name & Description	Mfr Code	Mfr Part Number
6-25	200-2414-02	B010100	B022212	1		COVER,ROM PACKS:4 POSITION,FINISHED,AL (OPTION 02 ONLY)	80009	200-2414-02
	200-2414-01	B022213		1		COVER,ROM PACKS:4 POSITION,TEK TAN (OPTION 02 ONLY)	80009	200-2414-01
	200-2414-02	B010100	B022217	1		COVER,ROM PACKS:4 POSITION,FINISHED,AL (OPTION 03 ONLY)	80009	200-2414-02
	200-2414-01	B022218		1		COVER,ROM PACKS:4 POSITION,TEK TAN (OPTION 03 ONLY)	80009	200-2414-01
-26	211-0530-00			4		SCREW,MACHINE:6-32 X 1.75 INCH,PNH STL ***** (ATTACHING PARTS) ***** ***** (END ATTACHING PARTS) *****	83385	OBD
-27	351-0609-00			1		GUIDE,ROM PACK:ALUMINUM ***** (ATTACHING PARTS) *****	80009	351-0609-00
-28	211-0504-00			2		SCREW,MACHINE:6-32 X 0.25 INCH,PNH STL ***** (END ATTACHING PARTS) *****	83385	OBD
-29	381-0420-00			1		BAR,SUPPORT:CONNECTOR ***** (ATTACHING PARTS) *****	80009	381-0420-00
-30	211-0198-00			4		SCREW,MACHINE:4-40 X 0.438 PNH,STL,POZ ***** (END ATTACHING PARTS) *****	77250	OBD
-31	-----			1		CKT BOARD ASSY:CONNECTOR(SEE A17 REPL)		
-32	131-1757-01			4		.CONN,RCPT,ELEC:CKT BD,24/44 CONT	05574	3VH22/1JND5
-33	214-3005-00			4		.KEY,CONN PLZN:NYLON	80009	214-3005-00
-34	131-2514-00			3		.CONN,RCPT,ELEC:CKT BD,2 X 10,MALE	00779	86479-1
-35	-----			1		CKT BOARD ASSY:SELECTOR(SEE A12,A13 REPL) ***** (ATTACHING PARTS) *****		
-36	211-0504-00			2		SCREW,MACHINE:6-32 X 0.25 INCH,PNH STL	83385	OBD
-37	211-0551-00			2		SCREW,MACHINE:6-32 X 0.562 INCH,PNH STL ***** (END ATTACHING PARTS) *****	83385	OBD
	-----			-		CKT BOARD ASSY INCLUDES:		
-38	129-0248-00			2		.SPACER,POST:0.663 INCH LONG,BRS	80009	129-0248-00
-39	-----			1		.CONN,RCPT,ELEC:(SEE A12,A13P5 REPL) ***** (ATTACHING PARTS) *****		
-40	211-0198-00			2		.SCREW,MACHINE:4-40 X 0.438 PNH,STL,POZ ***** (END ATTACHING PARTS) *****	77250	OBD
-41	214-1458-00	B010100	B022499	1		.KEY,CONN PLZN:CKT BOARD	05574	091-0071-000
-42	-----			3		.CONN,RCPT,ELEC:(SEE A12,A13P96,P97,P98 RE		
-43	136-0269-02			1		.SKT,PL-IN ELEK:MICROCIRCUIT,14 DIP,LOW CL (OPTION 3 ONLY)	73803	CS9002-14
-44	-----			1		.SOCKET,PLUG-IN:49 DIP,LOW PROFILE (OPTION 3 ONLY)		
-45	131-0608-00			9		.TERMINAL,PIN:0.365 L X 0.025 PH BRZ GOLD (OPTION 3 ONLY)	22526	47357
-46	131-0993-00			3		.BUS,CONDUCTOR:2 WIRE BLACK (OPTION 3 ONLY)	00779	850100-01
-47	129-0561-00			2		.SPACER,POST:0.535 L,W-4-40 INTL ONE END (OPTION 3 ONLY)	80009	129-0561-00
-48	-----			1		.CONN,RCPT,ELEC:(SEE A13J93 REPL) (OPTION 3 ONLY)		
-49	131-0890-00			2		LOCK,CONNECTOR:4-40 X 0.312 L (OPTION 3 ONLY)	71468	D 20418-2
-50	200-1887-00			1		COVER,FIRMWARE:PLASTIC (OPTION 2 ONLY) ***** (ATTACHING PARTS) *****	80009	200-1887-00
-51	211-0097-00			2		SCREW,MACHINE:4-40 X 0.312 INCH,PNH STL (OPTION 2 ONLY)	83385	OBD
-52	210-0586-00			2		NUT,PL,ASSEM WA:4-40 X 0.25,STL (OPTION 2 ONLY) ***** (END ATTACHING PARTS) *****	83385	OBD

REPLACEABLE MECHANICAL PARTS

Fig. & Index No.	Tektronix Part No.	Serial/Model No.		Qty						Name & Description	Mfr Code	Mfr Part Number
		Eff	Dscont		1	2	3	4	5			
7-1	380-0384-01			1						HSG HALF,ROM PK:LID,ABS *****ATTACHING PARTS)*****	80009	380-0384-01
-2	211-0102-00			4						SCREW,MACHINE:4-40 X 0.500",FLH,STL *****END ATTACHING PARTS)*****	83385	OBD
-3	367-0189-00			1						HANDLE,BOW:2.62 L,SST	91260	OBD
-4	380-0343-01			1						HSG HALF,PTR:INNER,ABS	80009	380-0343-01
	-----			1						MKR,SET,IDENT:MKD EDITOR ROM PACK (4052R06 ONLY)		
-4.1	334-2954-01			5						OVERLAY,KYBD:MARKED EDITOR ROM PACK (4052R06 ONLY)	80009	334-2954-01
	-----			1						CKT BOARD ASSY:16K ROM PACK(SEE A15,A16 RE		
-5	-----			1						.SKT,PL-IN ELEK:MICROCKT,24 PIN,LOW PROFIL	73803	C S9002-24
-6	136-0578-00			1								
-7	-----			1						MKR SET,IDENT:MKD 4052 SIG PROC #1 (4052R07 ONLY)		
	-----			-								

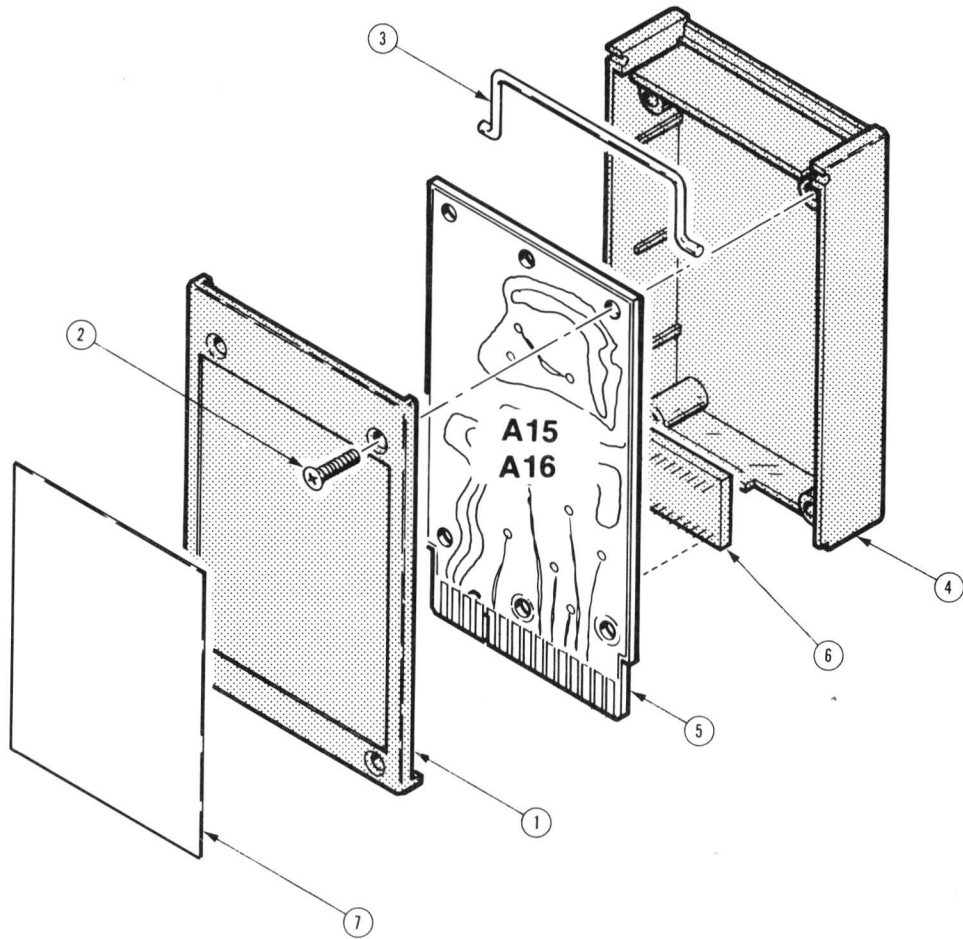
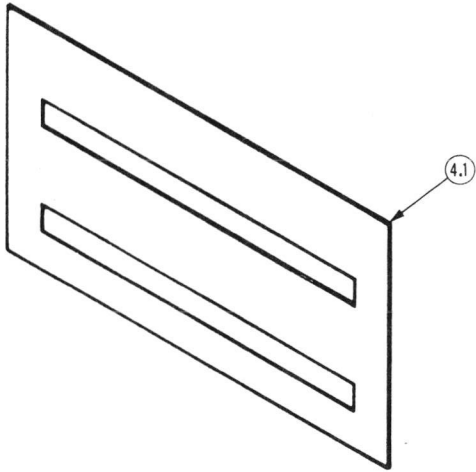

REV JUL 1982

4052/4052A PARTS AND SCHEMATICS

FIG. 7 ROM PACKS

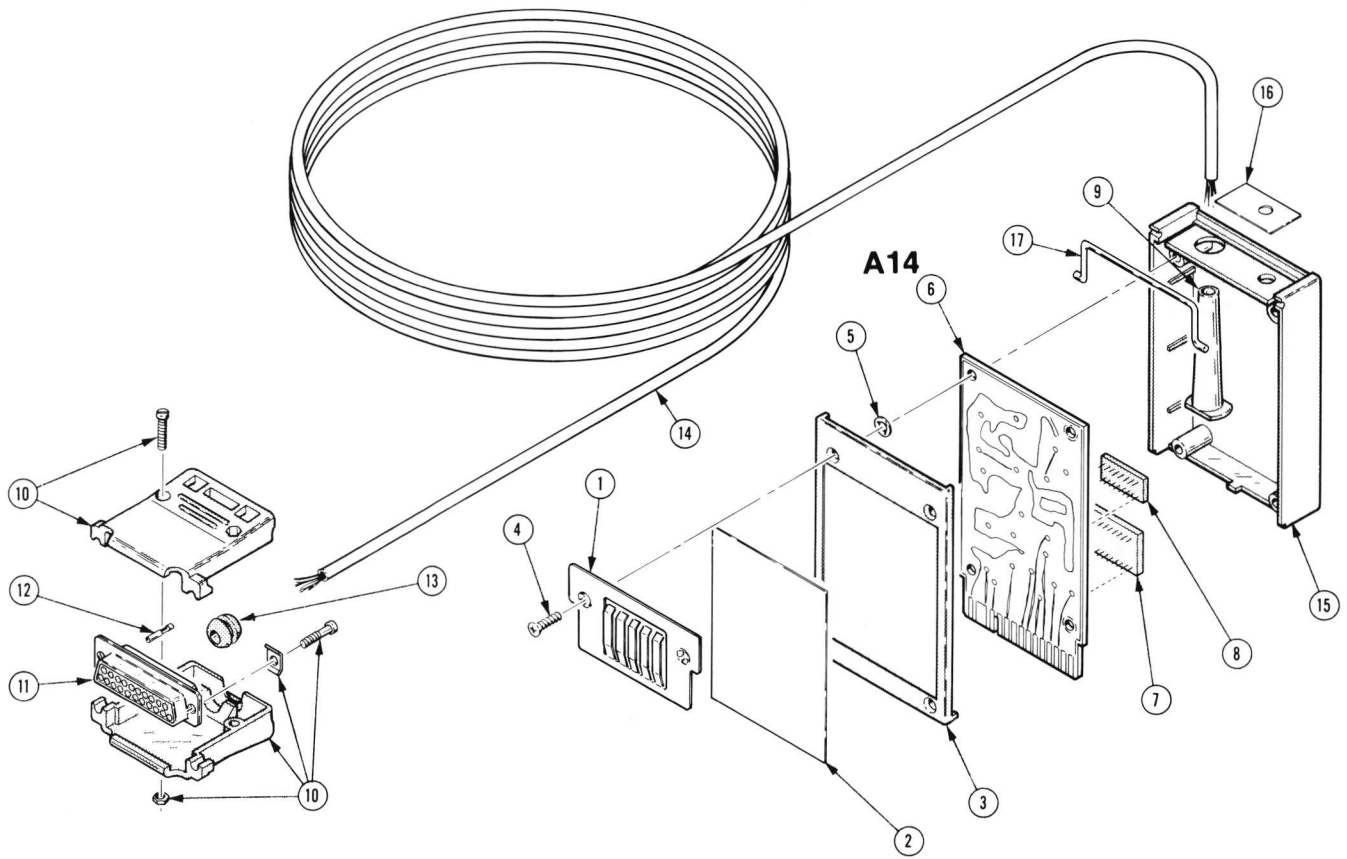

REPLACEABLE MECHANICAL PARTS

Fig. & Index No.	Tektronix Part No.	Serial/Model No.		Qty	1 2 3 4 5					Name & Description	Mfr Code	Mfr Part Number
		Eff	Dscont									
8-1	131-2442-00			1						CONTACT,ELEC:GROUNDING,PH BRZ	80009	131-2442-00
-2	334-3693-00			1						MARKER,IDENT:MKD RS232 PRINTER	80009	334-3693-00
	334-1377-00			1						MARKER,IDENT:MYLAR	07416	OBD
-3	380-0384-01			1						HSG HALF,ROM PK:LID,ABS ***** (ATTACHING PARTS) *****	80009	380-0384-01
-4	211-0102-00			4						SCREW,MACHINE:4-40 X 0.500",FLH,STL ***** (END ATTACHING PARTS) *****	83385	OBD
-5	210-1333-00			2						WASHER,FLAT:0.09 ID X 0.007 THK,CU BE	80009	210-1333-00
-6	-----			1						CKT BOARD ASSY:RS232(SEE A14 REPL)		
-7	136-0578-00	B010100	B034787	1						.SKT,PL-IN ELEK:MICROCKT,24 PIN,LOW PROFIL	73803	C S9002-24
	136-0751-00	B034788		1						.SKT,PL-IN ELEK:MICROCKT,24 PIN	09922	DILB24P108
-8	136-0260-02	B010100	B034787	1						.SKT,PL-IN ELEK:MICROCIRCUIT,16 DIP,LOW CL	71785	133-51-92-008
-9	200-1042-03			1						.CABLE NIP,ELEC:0.194 ID,2.0 L,PLASTIC	80009	200-1042-03
	175-2430-00			1						.CA ASSY,SP,ELEC:7,26 AWG,3 METERS	80009	175-2430-00
-10	200-1667-00			1						..SHLD ELEC CONN:25 CONTACT,TYPE HD SIZE 3	80009	200-1667-00
-11	131-1461-00			1						..CONN BODY,RCPT:25 FEMALE CONTACTS	00779	205207-1
-12	131-1279-01			8						..CONTACT,ELEC:FEMALE	00779	66505-4
-13	348-0020-00			1						..GROMMET,RUBBER:0.25 INCH	70485	374
-14	175-1747-00			AR						..CABLE,SP,ELEC:7,26 AWG,0.165 DIA	80009	175-1747-00
-15	380-0343-03			1						.HSG HALF,PTR:INNER,ABS	80009	380-0343-03
-16	334-3638-00			1						.MARKER,IDENT:MARKED BAUD RATE	80009	334-3638-00
-17	367-0189-00			1						HANDLE,BOW:2.62 L,SST	91260	OBD
										OPTION 10 STANDARD ACCESSORIES		
	070-2908-00			1						MANUAL,TECH:INSTRUCTION	80009	070-2908-00

REPLACEABLE MECHANICAL PARTS

Fig. & Index No.	Tektronix Part No.	Serial/Model No.		Qty	1	2	3	4	5	Name & Description	Mfr Code	Mfr Part Number
		Eff	Dscont									
STANDARD ACCESSORIES												
-1	161-0066-00			1						CABLE ASSY,PWR:;3,18 AWG,115V,98.0 L	S3109	1100
-2	161-0066-09			1						CABLE ASSY,PWR:3,0.75MM SQ,220V,96.0 L	80009	161-0066-09
	-----			-						(OPTION A1 ONLY)		
-3	161-0066-10			1						CABLE ASSY,PWR:3,0.75MM SQ,240V,96.0 L	80009	161-0066-10
	-----			-						(OPTION A2 ONLY)		
-4	161-0066-11			1						CABLE ASSY,PWR:3,0.75MM,240V,96.0L	80009	161-0066-11
	-----			-						(OPTION A3 ONLY)		
-5	161-0066-12			1						CABLE ASSY,PWR:3,18 AWG,240V,96.0 L	70903	OBD
	-----			-						(OPTION A4 ONLY)		
-6	161-0154-00			1						CABLE ASSY,PWR:3,0.75MM SQ,240V,6A,2.5M L	000JA	A25SW
	-----			-						(OPTION A5 ONLY)		
	020-0160-02	B010100	B020823	1						TAPE CARTRIDGE:PLOT 50 SYSTEM SOFTWARE	80009	020-0160-02
	020-0160-03	B020824		1						TAPE CARTRIDGE:PLOT 50 SYSTEM SOFTWARE	80009	020-0160-03
	020-0161-02	B010100	B020823	1						TAPE CARTRIDGE:PLOT 50 SYSTEM SOFTWARE	80009	020-0161-02
	020-0161-03	B020824		1						TAPE CARTRIDGE:PLOT 50 SYSTEM SOFTWARE	80009	020-0161-03
	016-0353-00			1						BDR,LOOSE-LEAF:2.0 CAP RING,VINYL COVER	80009	016-0353-00
	016-0367-00			1						BDR,LOOSE-LEAF:2.0 CAP RING,VINYL COVER	80009	016-0367-00
	016-0369-00			1						DIV,LOOSE LEAF:6 OVERLAY POCKETS,VINYL	80009	016-0369-00
	334-3571-00			1						MARKER,IDENT:MARKED OPERATORS MANUAL	80009	334-3571-00
	334-3572-00			1						MARKER,IDENT:MARKED REFERENCE	80009	334-3572-00
	-----			1						OVERLAY,KYBD:BLANK		
	070-1940-01			1						MANUAL,TECH:OPERATOR 4050 SERIES	80009	070-1940-01
	070-2056-01			1						MANUAL,TECH:REFERENCE	80009	070-2056-01
	070-2142-01			1						CARD,INFO:REFERENCE	80009	070-2142-01
	070-2058-01			1						MANUAL,TECH:INSTRUCTION	80009	070-2058-01
	070-2059-01			1						MANUAL,TECH:INSTRUCTION	80009	070-2059-01
OPTIONAL ACCESSORIES												
	012-0630-01			1						CABLE,INTCON:2 METERS LONG	74868	AC30111102 REVC
	119-1097-00	B010100	B105979	1						CARTRIDGE,TAPE:MAGNETIC TAPE W/O LABEL	80009	119-1097-00
	119-0680-01	B105980		1						CARTRIDGE,TAPE:MAGNETIC	80009	119-0680-01
	334-2630-02			1						OVERLAY,KYBD:BLANK,PACKAGE OF TEN	80009	334-2630-02
	070-2829-01			1						MANUAL,TECH:SERVICE	80009	070-2829-01
	016-0364-00			1						PEDESTAL KIT:	80009	016-0364-00
	070-4459-00			1						SHEET,TECHNICAL:INST,4054	80009	070-4459-00

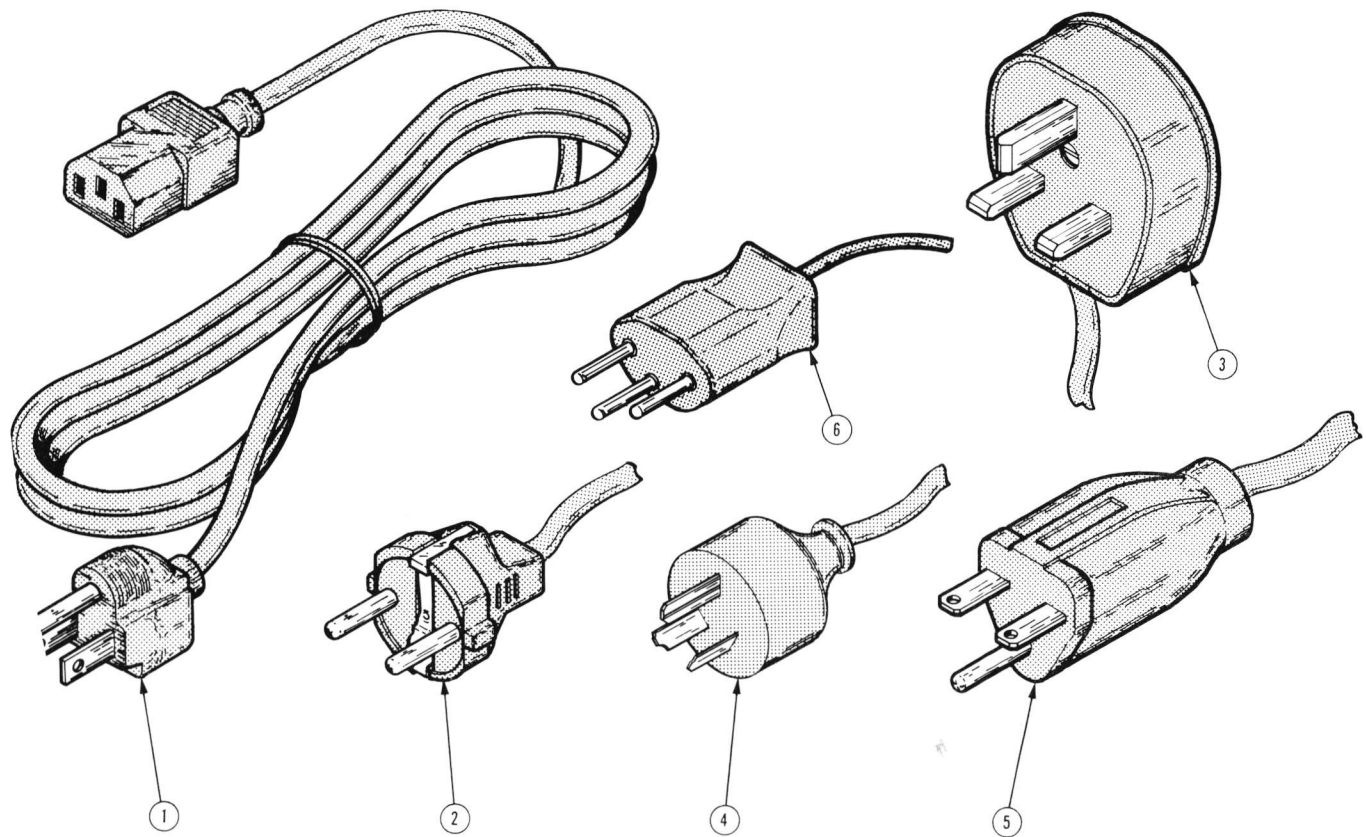

OPTIONS

OPT	ORDER NO.	DESCRIPTION
01	4052F01	FLD INSTL INTFC:DATA COMMUNICATION
02	4052F02	FIELD INSTALLED:4 SLOT ROM BACKPACK
03	4052F03	FLD INSTL INTFC:DATA COMM 4 SLOT
10	4052F10	FLD INSTL INTFC:RS232 PRINTER
24		MOD KIT:MEMORY EXPANSION
27	4052F27	EXTENDED MEMORY:256K
28	4052F28	EXTENDED MEMORY:512K
A1		UNIVERSAL EUROPEAN:POWER OPTION
A2		240V UK POWER:OPTION
A3		240V AUSTRALIAN:POWER OPTION
A4		240V NORTH AMERICAN:POWER OPTION
A5		220V SWISS:POWER OPTION

OPTIONS

Section 9

REPLACEABLE MECHANICAL PARTS

PARTS ORDERING INFORMATION

Replacement parts are available from or through your local Tektronix, Inc. Field Office or representative.

Changes to Tektronix instruments are sometimes made to accommodate improved components as they become available, and to give you the benefit of the latest circuit improvements developed in our engineering department. It is therefore important, when ordering parts, to include the following information in your order: Part number, instrument type or number, serial number, and modification number if applicable.

If a part you have ordered has been replaced with a new or improved part, your local Tektronix, Inc. Field Office or representative will contact you concerning any change in part number.

Change information, if any, is located at the rear of this manual.

ITEM NAME

In the Parts List, an Item Name is separated from the description by a colon (:). Because of space limitations, an Item Name may sometimes appear as incomplete. For further Item Name identification, the U.S. Federal Cataloging Handbook H6-1 can be utilized where possible.

FIGURE AND INDEX NUMBERS

Items in this section are referenced by figure and index numbers to the illustrations.

INDENTATION SYSTEM

This mechanical parts list is indented to indicate item relationships. Following is an example of the indentation system used in the description column.

```

1 2 3 4 5           Name & Description
Assembly and/or Component
Attaching parts for Assembly and/or Component
    - - - * - - -
Detail Part of Assembly and/or Component
Attaching parts for Detail Part
    - - - * - - -
Parts of Detail Part
Attaching parts for Parts of Detail Part
    - - - * - - -
  
```

Attaching Parts always appear in the same indentation as the item it mounts, while the detail parts are indented to the right. Indented items are part of, and included with, the next higher indentation. The separation symbol - - - * - - - indicates the end of attaching parts.

Attaching parts must be purchased separately, unless otherwise specified.

ABBREVIATIONS

INCH	ELCTRN	ELECTRON	IN	INCH	SE	SINGLE END
# NUMBER SIZE	ELEC	ELECTRICAL	INCAND	INCANDESCENT	SECT	SECTION
ACTR ACTUATOR	ELCTLT	ELECTROLYTIC	INSUL	INSULATOR	SEMICON	SEMICONDUCTOR
ADPTR ADAPTER	ELEM	ELEMENT	INTL	INTERNAL	SHLD	SHIELD
ALIGN ALIGNMENT	EPL	ELECTRICAL PARTS LIST	LPHLDR	LAMPHOLDER	SHLDR	SHOULDERED
AL ALUMINUM	EQPT	EQUIPMENT	MACH	MACHINE	SKT	SOCKET
ASSEM ASSEMBLED	EXT	EXTERNAL	MECH	MECHANICAL	SL	SLIDE
ASSY ASSEMBLY	FIL	FILLISTER HEAD	MTG	MOUNTING	SLFLKG	SELF-LOCKING
ATTEN ATTENUATOR	FLEX	FLEXIBLE	NIP	NIPPLE	SLVG	SLEEVEING
AWG AMERICAN WIRE GAGE	FLH	FLAT HEAD	NON WIRE	NOT WIRE WOUND	SPR	SPRING
BD BOARD	FLTR	FILTER	OBD	ORDER BY DESCRIPTION	SQ	SQUARE
BRKT BRACKET	FR	FRAME or FRONT	OD	OUTSIDE DIAMETER	SST	STAINLESS STEEL
BRS BRASS	FSTNR	FASTENER	OVH	OVAL HEAD	STL	STEEL
BRZ BRONZE	FT	FOOT	PH BRZ	PHOSPHOR BRONZE	SW	SWITCH
BSHG BUSHING	FXD	FIXED	PL	PLAIN or PLATE	T	TUBE
CAB CABINET	GSKT	GASKET	PLSTC	PLASTIC	TERM	TERMINAL
CAP CAPACITOR	HDL	HANDLE	PN	PART NUMBER	THD	THREAD
CER CERAMIC	HEX	HEXAGON	PNH	PAN HEAD	THK	THICK
CHAS CHASSIS	HEX HD	HEXAGONAL HEAD	PWR	POWER	TNSN	TENSION
CKT CIRCUIT	HEX SOC	HEXAGONAL SOCKET	RCPT	RECEPTACLE	TPG	TAPPING
COMP COMPOSITION	HLCPS	HELICAL COMPRESSION	RES	RESISTOR	TRH	TRUSS HEAD
CONN CONNECTOR	HLEXT	HELICAL EXTENSION	RGD	RIGID	V	VOLTAGE
COV COVER	HV	HIGH VOLTAGE	RLF	RELIEF	VAR	VARIABLE
CPLG COUPLING	IC	INTEGRATED CIRCUIT	RTNR	RETAINER	W/	WITH
CRT CATHODE RAY TUBE	ID	INSIDE DIAMETER	SCH	SOCKET HEAD	WSHR	WASHER
DEG DEGREE	IDENT	IDENTIFICATION	SCOPE	OSCILLOSCOPE	XFMR	TRANSFORMER
DWR DRAWER	IMPLR	IMPELLER	SCR	SCREW	XSTR	TRANSISTOR

REPLACEABLE MECHANICAL PARTS

CROSS INDEX—MFR. CODE NUMBER TO MANUFACTURER

Mfr. Code	Manufacturer	Address	City, State, Zip
000AE	GARDNER SPRING COMPANY	1115 N UTICA	TULSA, OK 74110
000AH	STANDARD PRESSED STEEL CO., UNBRAKO DIV.	8535 DICE ROAD	SANTA FE SPRINGS, CA 90670
000BK	STAUFFER SUPPLY	105 SE TAYLOR	PORTLAND, OR 97214
000CY	NORTHWEST FASTENER SALES, INC.	7923 SW CIRBUS DRIVE	BEAVERTON, OR 97005
000JA	J. PHILLIP INDUSTRIES INC.	5713 NORTHWEST HIGHWAY	CHICAGO, ILL 60646
00779	AMP, INC.	P.O. BOX 3608	HARRISBURG, PA 17105
01295	TEXAS INSTRUMENTS, INC. SEMICONDUCTOR GROUP	P.O. BOX 5012	DALLAS, TX 75222
01881	ANACONDA AMERICAN BRASS COMPANY, A DIV. OF ANACONDA COMPANY	414 MEADOW STREET	WATERBURY, CT 06720
01963	CHERRY ELECTRICAL PRODUCTS CORPORATION	3600 SUNSET AVENUE	WAUKEGAN, IL 60085
04009	ARROW-HART, INC.	103 HAWTHORNE STREET	HARTFORD, CT 06106
04919	COMPONENT MANUFACTURING SERVICE, INC.	1 COMPONENT PARK WEST	BRIDGEWATER, MA 02379
04963	MINNESOTA MINING AND MFG. CO., ADHESIVES COATINGS AND SEALERS DIVISION	3M CENTER	ST. PAUL, MN 55101
05574	VIKING INDUSTRIES, INC.	21001 NORDHOFF STREET	CHATSWORTH, CA 91311
05820	WAKEFIELD ENGINEERING, INC.	AUDUBON ROAD	WAKEFIELD, MA 01880
06090	RAYCHEM CORPORATION	300 CONSTITUTION DRIVE	MENLO PARK, CA 94025
06383	PANDUIT CORPORATION	17301 RIDGELAND	TINLEY PARK, IL 60477
07322	MINNESOTA RUBBER CO.	3630 WOODDALE AVENUE	MINNEAPOLIS, MN 55416
07707	USM CORP., USM FASTENER DIV.	510 RIVER RD.	SHELTON, CT 06484
08261	SPECTRA-STRIP CORP.	7100 LAMPSON AVE.	GARDEN GROVE, CA 92642
09922	BURNDY CORPORATION	RICHARDS AVENUE	NORWALK, CT 06852
11897	PLASTIGLIDE MFG. CORPORATION	P O BOX 867, 1757 STANFORD ST.	SANTA MONICA, CA 90406
11983	NORTRONICS COMPANY, INC.	8101 10TH AVENUE NORTH	MINNEAPOLIS, MN 55427
12327	FREEWAY CORPORATION	9301 ALLEN DRIVE	CLEVELAND, OH 44125
12578	MINNESOTA MINING & MFG CO. MINCOM DIV	300 S LEWIS RD.	CAMARILLO, CA 93010
15819	SINCLAIR AND RUSH INC.	6919 SOUTH BROADWAY	ST. LOUIS, MO 63111
18722	RCA CORP., SOLID STATE DIVISION	CRESTWOOD ROAD	MOUNTAINTOP, PA 18707
20999	MINNESOTA MINING AND MFG CO., INDUSTRIAL ELECTRICAL PRODUCTS DIVISION	3M CENTER	ST. PAUL, MN 55101
22526	BERG ELECTRONICS, INC.	YOUK EXPRESSWAY	NEW CUMBERLAND, PA 17070
22599	ESNA, DIV. OF AMERACE CORPORATION	16150 STAGG STREET	VAN NUYS, CA 91409
24931	SPECIALITY CONNECTOR CO., INC.	2620 ENDRESS PLACE	GREENWOOD, IN 46142
26365	GRIES REPRODUCER CO., DIV. OF COATS AND CLARK, INC.	125 BEECHWOOD AVE.	NEW ROCHELLE, NY 10802
27264	MOLEX PRODUCTS CO.	5224 KATRINE AVE.	DOWNERS GROVE, IL 60515
28520	HEYMAN MFG. CO.	147 N. MICHIGAN AVE.	KENILWORTH, NJ 07033
50778	PORTESCAP, US	730 FIFTH AVENUE	NEW YORK, NEW YORK 10019
52905	SIMPLEX MFG. COMPANY	5224 NE 42ND AVENUE	PORTLAND, OREGON 97218
53387	MINNESOTA MINING AND MFG. CO., ELECTRO PRODUCTS DIVISION	3M CENTER	ST. PAUL, MN 55101
55285	BERGQUIST CO. INC.	5300 EDINA INDUSTRIAL BLVD	MINNEAPOLIS, MN 55435
56289	SPRAGUE ELECTRIC CO.	87 MARSHALL ST.	NORTH ADAMS, MA 01247
70276	ALLEN MFG. CO.	P. O. DRAWER 570	HARTFORD, CT 06101
70485	ATLANTIC INDIA RUBBER WORKS, INC.	571 W. POLK ST.	CHICAGO, IL 60607
70903	BELDEN CORP.	2000 S BATAVIA AVENUE	GENEVA, IL 60134
71468	ITT CANNON ELECTRIC	666 E. DYER RD.	SANTA ANA, CA 92702
71785	TRW, CINCH CONNECTORS	1501 MORSE AVENUE	ELK GROVE VILLAGE, IL 60007
73743	FISCHER SPECIAL MFG. CO.	446 MORGAN ST.	CINCINNATI, OH 45206
73803	TEXAS INSTRUMENTS, INC., METALLURGICAL MATERIALS DIV.	34 FOREST STREET	ATTLEBORO, MA 02703
74868	BUNKER-RAMO CORP., THE AMPHENOL RF DIV.	33 E. FRANKLIN ST.	DANBURY, CT 06810
74921	ITEN FIBRE CO.,	4001 BENEFIT AVE., P O BOX 9	ASHTABULA, OH 44004
77250	PHEOLL MANUFACTURING CO., DIVISION OF ALLIED PRODUCTS CORP.	5700 W. ROOSEVELT RD.	CHICAGO, IL 60650
78189	ILLINOIS TOOL WORKS, INC. SHAKEPROOF DIVISION	ST. CHARLES ROAD	ELGIN, IL 60120
79136	WALDES, KOHINOOR, INC.	47-16 AUSTEL PLACE	LONG ISLAND CITY, NY 11101
80009	TEKTRONIX, INC.	P O BOX 500	BEAVERTON, OR 97077
81041	HOWARD INDUSTRIES, DIVISION OF MSL INDUSTRIES, INC.	P O BOX 287	MILFORD, IL 60953
83385	CENTRAL SCREW CO.	2530 CRESCENT DR.	BROADVIEW, IL 60153
85471	BOYD, A. B., CO.	2527 GRANT AVENUE	SAN LEANDRO, CA 94579
86445	PENN FIBRE AND SPECIALTY CO., INC.	2032 E. WESTMORELAND ST.	PHILADELPHIA, PA 19134
86928	SEASTROM MFG. COMPANY, INC.	701 SONORA AVENUE	GLENDALE, CA 91201
87308	N. L. INDUSTRIES, INC., SOUTHERN SCREW DIV.	P. O. BOX 1360	STATESVILLE, NC 28677

CROSS INDEX—MFR. CODE NUMBER TO MANUFACTURER

Mfr. Code	Manufacturer	Address	City, State, Zip
91260	CONNOR SPRING AND MFG. CO.	1729 JUNCTION AVE.	SAN JOSE, CA 95112
93907	TEXTRON INC. CAMCAR DIV	600 18TH AVE	ROCKFORD, IL 61101
95987	WECKESSER CO., INC.	4444 WEST IRVING PARK RD.	CHICAGO, IL 60641
98291	SEAELECTRO CORP.	225 HOYT	MAMARONECK, NY 10544
98938	PITTMAN CORPORATION, A SUBSIDIARY OF PENN ENGINEERING AND MFG. CORPORATION	P O BOX 150 W PARK AVE.	SELLERSVILLE, PA 18960
S3109	C/O PANEL COMPONENTS CORP.	P.O. BOX 6626	SANTA ROSA, CA 95406
S3629	PANEL COMPONENTS CORP.	2015 SECOND ST.	BERKELEY, CA 94170

REPLACEABLE MECHANICAL PARTS

Fig. & Index No.	Tektronix Part No.	Serial/Model No. Eff	Dscont	Qty	1	2	3	4	5	Name & Description	Mfr Code	Mfr Part Number
1-1	390-0490-03			1						CAB.TOP,CALC:W/BRACKETS & CLIP ***** (ATTACHING PARTS) *****	80009	390-0490-03
-2	212-0543-00			2						SCREW,MACHINE:10-32 X 3.750 HEX HD	83385	OBD
-3	210-0805-00			2						WASHER,FLAT:0.204 ID X 0.438 INCH OD,ST	12327	OBD
-4	210-0010-00			2						WASHER,LOCK:INT,0.20 ID X 0.376" OD,STL	78189	1210-00-00-0541C
-5	348-0020-00			2						GROMMET,RUBBER:0.25 INCH	70485	374
-6	212-0507-00			2						SCREW,MACHINE:10-32 X 0.375 INCH,PNH STL ***** (END ATTACHING PARTS) *****	83385	OBD
	334-3741-00			1						MARKER,IDENT:MKD FIRMWARE LEVEL	80009	334-3741-00
-7	334-3374-00			1						MARKER,IDENT:MARKED TEKTRONIX	80009	334-3374-00
-8	333-2510-00			1						PANEL,FRONT:4052	80009	333-2510-00
-9	426-1253-01			1						FRAME SECT,CAB.:FRONT ***** (ATTACHING PARTS) *****	80009	426-1253-01
-10	211-0559-00			2						SCREW,MACHINE:6-32 X 0.375"100 DEG,FLH ST	83385	OBD
-11	211-0512-00			2						SCREW,MACHINE:6-32 X 0.50" 100 DEG,FLH ST	83385	OBD
-12	212-0075-00			2						SCREW,MACHINE:8-32 X 0.250,TRH,STL,NI PL ***** (END ATTACHING PARTS) *****	77250	OBD
-13	131-1846-00			1						CONTACT,ELEC:GROUNDING ***** (ATTACHING PARTS) *****	80009	131-1846-00
-14	213-0088-00			1						SCR,TPG,THD CTG:4-24 X 0.25 INCH,PNH STL ***** (END ATTACHING PARTS) *****	83385	OBD
-15	260-1842-00			1						SWITCH,ROCKER:DPST,16A,250VAC (PART OF 175-2302-00)	04009	2600-11E 718
-16	200-2301-00			1						COVER,SWITCH:POWER,SILICONE RUBBER (PART OF 175-2302-00)	80009	200-2301-00
-17	390-0700-00			1						CAB.SIDE,CALC:LEFT,FINISHED	80009	390-0700-00
-18	390-0699-00			1						CAB.SIDE,CALC:RIGHT,FINISHED ***** (ATTACHING PARTS) *****	80009	390-0699-00
-19	211-0510-00			10						SCREW,MACHINE:6-32 X 0.375,PNH,STL,CD PL	83385	OBD
-20	210-0006-00			10						WASHER,LOCK:#6 INTL,0.018 THK,STL CD PL ***** (END ATTACHING PARTS) *****	78189	1206-00-00-0541C
-21	348-0178-00			4						BUMPER,PLASTIC:2.0 W X 0.40 INCH H	80009	348-0178-00
-22	348-0177-00			4						PAD,CABINET FT:1.25 W X 0.50 INCH H ***** (ATTACHING PARTS) *****	80009	348-0177-00
-23	213-0041-00			8						SCR,TPG,THD CTG:6-32 X 0.375 INCH,TRH STL	83385	OBD
-24	210-0803-00			8						WASHER,FLAT:0.15 ID X 0.032 THK,STL CD ***** (END ATTACHING PARTS) *****	12327	OBD
-25	407-1696-00			1						BRACKET,ANGLE:REAR PANEL,ALUMINUM ***** (ATTACHING PARTS) *****	80009	407-1696-00
-26	212-0004-00			2						SCREW,MACHINE:8-32 X 0.312 INCH,PNH STL	83385	OBD
-27	210-0008-00			1						WASHER,LOCK:INTL,0.172 ID X 0.331"OD,S ***** (END ATTACHING PARTS) *****	78189	1208-00-00-0541C
-28	390-0482-04			1						CABINET BOTTOM:	80009	390-0482-04
-29	334-3410-00			1						OVERLAY,KYBD:MARKED USER DEFINABLE/LINE	80009	334-3410-00
-30	333-2499-00			1						PANEL,FRONT: ***** (ATTACHING PARTS) *****	80009	333-2499-00
-31	211-0019-00			10						SCREW,MACHINE:4-40 X 1.0 INCH,PNH STL ***** (END ATTACHING PARTS) *****	83385	OBD
-32	-----			1						KEYBOARD,CALC:(SEE A7 REPL) ***** (ATTACHING PARTS) *****		
-33	211-0542-00			2						SCREW,MACHINE:6-32 X 0.312 INCH,TRH STL	83385	OBD
-34	210-0803-00			2						WASHER,FLAT:0.15 ID X 0.032 THK,STL CD	12327	OBD
-35	210-0009-00			2						WASHER,LOCK:EXT,0.193ID X 0.40" OD,STL ***** (END ATTACHING PARTS) *****	78189	1110-00
	-----			-						KEYBOARD ASSY INCLUDES:		
-36	260-1393-01			2						.SWITCH,PUSH:SPST,NO,KYBD SW,HIGH ACTG F	01963	M51-0101
-37	118-0081-00			1						.SWITCH,PUSH:4051 KEYBOARD	01963	M61-0800
-38	260-1393-00			95						.SWITCH,PUSH:SPST,NO KEYBOARD SWITCH	01963	M61-0100
-39	119-0423-00			1						.SPACE BAR ASSY:	01963	B99-0003
-40	366-1790-02			1						.PUSH BUTTON:GOLD,HOME PAGE	01963	223-0201
	366-1790-01			1						.PUSH BUTTON:TV GRAY,LEFT BRACE/LEFT BRK	01963	223-0187
	366-1766-05			1						.PUSH BUTTON:LT GRAY,RIGHT BRACKET/1	01963	223-0094
	366-1790-18			1						.PUSH BUTTON:	01963	223-0180
	366-1766-03			1						.PUSH BUTTON:LT GRAY,#/3	01963	223-0096

REPLACEABLE MECHANICAL PARTS

Fig. & Index No.	Tektronix Part No.	Serial/Model No.		Qty						Name & Description	Mfr Code	Mfr Part Number
		Eff	Dscont		1	2	3	4	5			
1-	366-1766-02			1						.PUSH BUTTON:LT GRAY,DOLLAR/4	01963	223-0097
	366-1766-12			1						.PUSH BUTTON:LT GRAY,%/5	01963	223-0098
	366-1790-22			1						.PUSH BUTTON:TEK TAN,&/6	01963	223-0181
-41	366-1790-21			1						.PUSH BUTTON:TEK TAN '/7	01963	223-0182
	366-1790-19			1						.PUSH BUTTON:TEK TAN,(/8	01963	223-0183
	366-1790-20			1						.PUSH BUTTON:TEK TAN,)/9	01963	223-0184
	366-1790-17			1						.PUSH BUTTON:TEK TAN,0	01963	223-0190
	366-1790-16			1						.PUSH BUTTON:TEK TAN,*:/	01963	223-0185
	366-1790-15			1						.PUSH BUTTON:TEK TAN,=-/	01963	223-0186
	366-1790-14			1						.PUSH BUTTON:TV GRAY,RIGHT BRACE/RIGHT	01963	223-0188
	366-1790-13			1						.PUSH BUTTON:TV GRAY,BACK SPACE	01963	223-0191
	366-1790-12			1						.PUSH BUTTON:TV GRAY,ESC	01963	223-1128
	366-1790-11			1						.PUSH BUTTON:TV GRAY,TILDE/ARROW UP	01963	223-1129
	366-1766-63			1						.PUSH BUTTON:LT GRAY,Q	01963	223-1068
	366-1766-20			1						.PUSH BUTTON:LT GRAY,W	01963	223-1069
	366-1766-52			1						.PUSH BUTTON:LT GRAY,E	01963	223-1070
	366-1766-64			1						.PUSH BUTTON:LT GRAY,R	01963	223-1071
	366-1766-65			1						.PUSH BUTTON:LT GRAY,T	01963	223-1072
	366-1766-70			1						.PUSH BUTTON:LT GRAY,Y	01963	223-1073
	366-1766-67			1						.PUSH BUTTON:LT GRAY,U	01963	223-1074
	366-1766-43			1						.PUSH BUTTON:DK GRAY,1	01963	223-1075
	366-1766-61			1						.PUSH BUTTON:LT GRAY,O	01963	223-1076
	366-1766-62			1						.PUSH BUTTON:LT GRAY,P	01963	223-1077
	366-1790-10			1						.PUSH BUTTON:TEK TAN,@/BACK SPACE	01963	223-1130
	366-1790-09			1						.PUSH BUTTON:TV GRAY,LF	01963	223-1131
	366-1790-08			1						.PUSH BUTTON:TV GRAY,RETURN	01963	223-5554
	366-1790-07			1						.PUSH BUTTON:TV GRAY,TAB	01963	228-2016
	366-1766-42			1						.PUSH BUTTON:DK GRAY,CTRL	01963	228-3106
	366-1766-48			1						.PUSH BUTTON:LT GRAY,A	01963	228-6703
	366-1766-66			1						.PUSH BUTTON:LT GRAY,S	01963	228-6704
	366-1766-51			1						.PUSH BUTTON:LT GRAY,D	01963	228-6705
	366-1766-53			1						.PUSH BUTTON:LT GRAY,F	01963	228-5921
	366-1766-54			1						.PUSH BUTTON:LT GRAY,G	01963	228-6707
	366-1766-55			1						.PUSH BUTTON:LT GRAY,H	01963	228-6708
	366-1766-56			1						.PUSH BUTTON:LT GRAY,J	01963	228-5922
	366-1766-57			1						.PUSH BUTTON:LT GRAY,K	01963	228-6710
366-1766-58			1						.PUSH BUTTON:LT GRAY,L	01963	228-6711	
366-1790-06			1						.PUSH BUTTON:TEK TAN,+;/	01963	228-6712	
366-1790-05			1						.PUSH BUTTON:TV GRAY,BACK SLASH/'	01963	228-6674	
366-1790-04			1						.PUSH BUTTON:TV GRAY,RUB OUT	01963	228-6887	
-42	366-1790-03			1						.PUSH BUTTON:TV GRAY,TTY LOCK	01963	223-2106
	366-1766-29			1						.PUSH BUTTON:DK GRAY,SHIFT	01963	223-4502
	366-1766-71			1						.PUSH BUTTON:LT GRAY,Z	01963	223-2056
	366-1766-69			1						.PUSH BUTTON:LT GRAY,X	01963	223-2057
	366-1766-50			1						.PUSH BUTTON:LT GRAY,C	01963	223-2058
	366-1766-68			1						.PUSH BUTTON:LT GRAY,V	01963	223-2059
	366-1766-49			1						.PUSH BUTTON:LT GRAY,B	01963	223-2060
	366-1766-60			1						.PUSH BUTTON:LT GRAY,N	01963	223-2061
	366-1766-66			1						.PUSH BUTTON:LT GRAY,S	01963	228-6704
	366-1766-28			1						.PUSH BUTTON:LT GRAY,</	01963	223-2064
	366-1766-27			1						.PUSH BUTTON:LT GRAY,>/	01963	223-2064
	366-1766-26			1						.PUSH BUTTON:DK GRAY,?/SLASH	01963	223-2065
	366-1766-29			1						.PUSH BUTTON:DK GRAY,SHIFT	01963	223-4502
	366-1790-00			1						.PUSH BUTTON:GOLD,BREAK	01963	223-2105
	366-1790-23			1						.PUSH BUTTON:TV GRAY,(01963	228-6675
	366-1790-24			1						.PUSH BUTTON:TEK TAN,ENTER EXP	01963	228-6889
	366-1790-23			1						.PUSH BUTTON:TV GRAY,(01963	228-6675
	366-1790-26			1						.PUSH BUTTON:TV GRAY,ARROW UP	01963	228-6676
	366-1790-27			1						.PUSH BUTTON:TEK TAN,7	01963	228-6723
	366-1790-28			1						.PUSH BUTTON:TEK TAN,8	01963	228-6724
	366-1790-29			1						.PUSH BUTTON:TEK TAN,9	01963	228-6725
	366-1790-30			1						.PUSH BUTTON:TV GRAY,/	01963	228-6677
	366-1790-41			1						.PUSH BUTTON:TEK TAN,4	01963	228-6726
	366-1790-40			1						.PUSH BUTTON:TEK TAN,5	01963	228-3615
	366-1790-29			1						.PUSH BUTTON:TEK TAN,9	01963	228-6725
	366-1790-38			1						.PUSH BUTTON:TV GRAY,*	01963	228-6890

REPLACEABLE MECHANICAL PARTS

Fig. & Index No.	Tektronix Part No.	Serial/Model No.		Qty	1 2 3 4 5	Name & Description	Mfr Code	Mfr Part Number
		Eff	Dscont					
1-	366-1790-37			1		.PUSH BUTTON:TEK TAN,1	01963	228-6728
	366-1790-36			1		.PUSH BUTTON:TEK TAN,2	01963	228-6729
	366-1790-35			1		.PUSH BUTTON:TEK TAN,3	01963	228-6730
	366-1790-34			1		.PUSH BUTTON:TV GRAY,-	01963	228-6678
	366-1790-33			1		.PUSH BUTTON:TEK TAN,0	01963	228-0136
	366-1790-32			1		.PUSH BUTTON:TEK TAN,.	01963	228-6731
	366-1790-31			1		.PUSH BUTTON:TV GRAY,+	01963	228-6679
-43	366-1502-00			10		PUSH BUTTON:SIL GY,0.715 X 0.23 X 0.41	80009	366-1502-00
-44	366-1671-00			10		PUSH BUTTON:BLANK,DARK GRAY	80009	366-1671-00
-45	337-2662-00			1		SHIELD,ELEC:KEYBOARD ***** (ATTACHING PARTS) *****	80009	337-2662-00
-46	211-0021-00			2		SCREW,MACHINE:4-40 X 1.25 INCH,PNH STL ***** (END ATTACHING PARTS) *****	83385	OBD
-47	175-2302-00			1		CA ASSY,SP,ELEC:4,18 AWG,25.0 L	80009	175-2302-00
-48	131-0945-00			4		.CONTACT,ELEC:CONNECTOR,BRASS TIN PL	27264	02-09-2101
-49	131-0946-00			1		.CONNECTOR BODY,.;FEMALE,4 CONTACT .(SEE P1004 REPL)	27264	03-09-2041
-50	175-1577-00			1		.CABLE,SP,ELEC:4,18 AWG,TWISTED	80009	175-1577-00
-51	366-1522-00			1		KNOB:LINE VOLTAGE INDICATOR	80009	366-1522-00
-52	211-0507-00			1		SCREW,MACHINE:6-32 X 0.312 INCH,PNH STL	83385	OBD

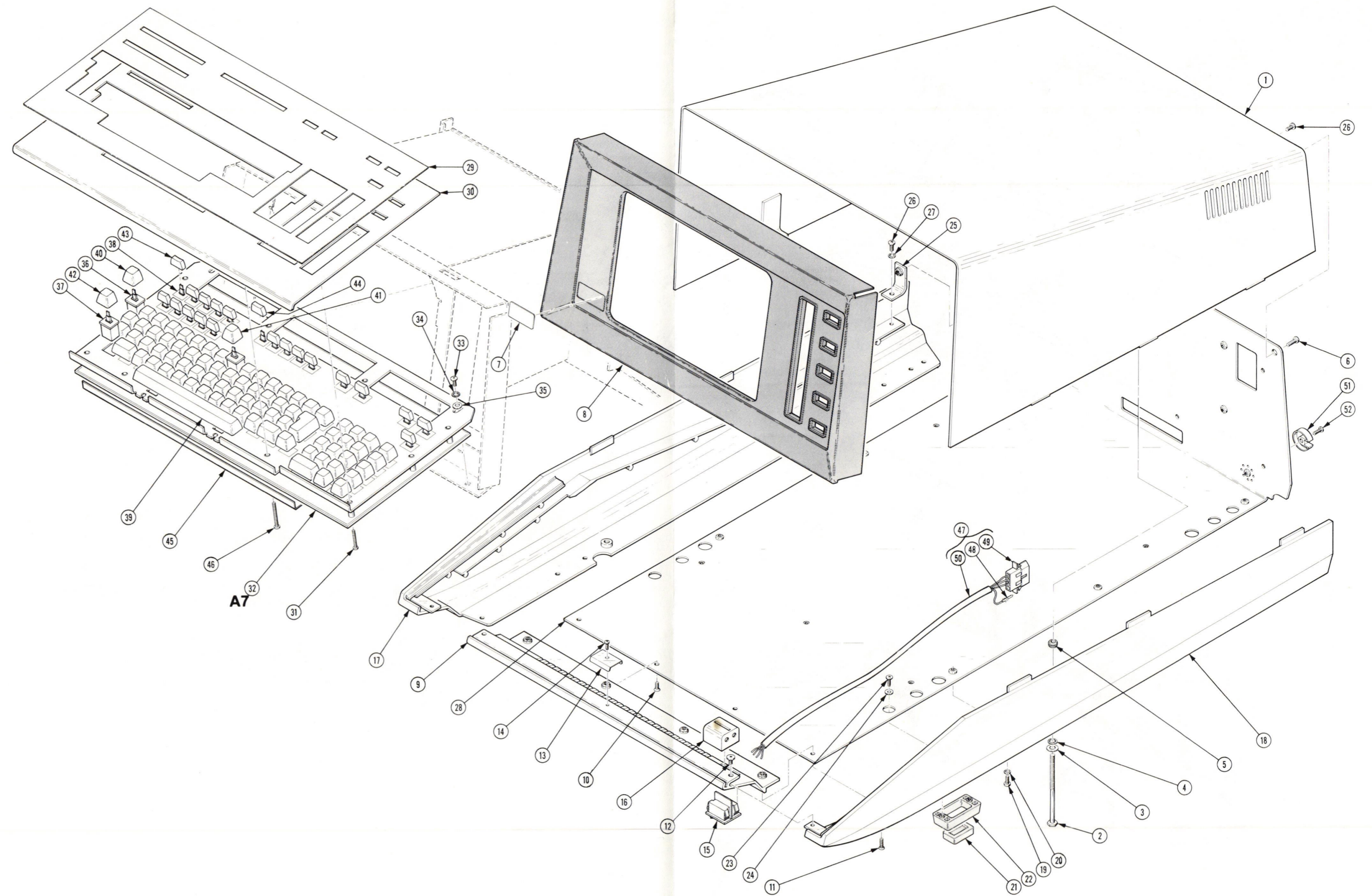

A7

ADD JUL 1982

4052/4052A PARTS AND SCHEMATICS

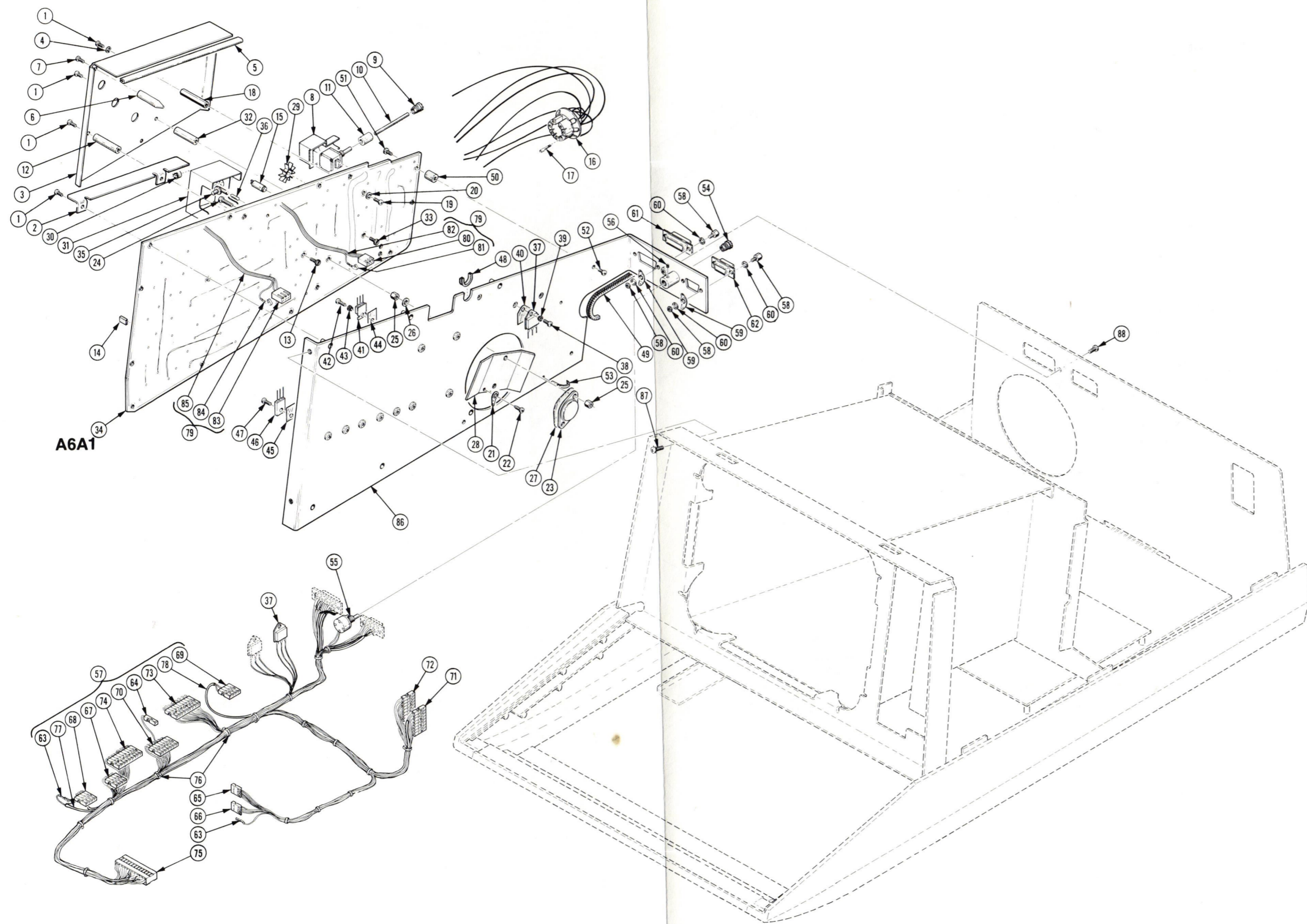

A6A1

REPLACEABLE MECHANICAL PARTS

Fig. & Index No.	Tektronix Part No.	Serial/Model No. Eff	Dscont	Qty	1	2	3	4	5	Name & Description	Mfr Code	Mfr Part Number
2-	-----			1						CKT BOARD ASSY:HARD COPY DISPLAY(SEE A6 RE *****ATTACHING PARTS)*****		
-1	211-0008-00			9						SCREW,MACHINE:4-40 X 0.250,PNH,STL,CD PL *****END ATTACHING PARTS)*****	83385	OBD
	-----			-						CKT BOARD ASSY INCLUDES:		
-2	337-2265-00			1						.SHIELD,ELEC:CIRCUIT CARD	80009	337-2265-00
-3	337-2251-00			1						.SHIELD,ELEC:HIGH VOLTAGE POWER SUPPLY *****ATTACHING PARTS)*****	80009	337-2251-00
-4	210-0004-00			1						.WASHER,LOCK:#4 INTL,0.015 THK,STL CD PL *****END ATTACHING PARTS)*****	000BK	OBD
-5	252-0571-00			1						.NEOPRENE EXTR:CHAN,0.234 X 0.156	85471	DIE#1353
-6	129-0588-00			1						.POST,ELEC-MECH:1.4 L,W/4-40 THD,NYLON *****ATTACHING PARTS)*****	80009	129-0588-00
-7	211-0008-00			1						.SCREW,MACHINE:4-40 X 0.250,PNH,STL,CD PL *****END ATTACHING PARTS)*****	83385	OBD
-8	200-1327-00			1						.SHIELD,RESISTOR:	80009	200-1327-00
-9	366-0261-02			1						.KNOB,GRAY,0.129 ID X 0.312 OD X	80009	366-0261-02
-10	384-1181-00			1						.EXTENSION SHAFT:1.840 INCH LONG	80009	384-1181-00
-11	376-0029-00			1						.CPLG,SHAFT,RGD:0.128 ID X 0.312 OD X 0.5"	80009	376-0029-00
	213-0075-00			1						.SETSCREW:4-40 X 0.094,STL BK OXD,HEX	000BK	OBD
-12	129-0369-00			1						.INSULATOR,STDF:1.370 INCH,W/4-40 THREAD *****ATTACHING PARTS)*****	80009	129-0369-00
-13	211-0040-00			1						.SCREW,MACHINE:4-40 X 0.25",BDGH PLSTC *****END ATTACHING PARTS)*****	26365	OBD
-14	131-0993-00			1						.BUS,CONDUCTOR:2 WIRE BLACK	00779	850100-01
-15	131-1834-00			2						.TERMINAL,STUD:0.89 L,W/NYLON INSULATOR	98291	023-3000-000-689
	136-0647-01			1						.SKT,PL-IN ELEK:ELCTR N TUBE,7 CONT,W/LEADS	80009	136-0647-01
-16	136-0278-00			1						.SOCKET,PLUG-IN:WITH PINS	80009	136-0278-00
-17	214-0464-00			7						.CONTACT,ELEC:CRT	80009	214-0464-00
-18	384-0616-00			1						.POST,ELEC-MECH:HEX,0.25 X 1.370 INCH LONG *****ATTACHING PARTS)*****	80009	384-0616-00
-19	211-0008-00			1						.SCREW,MACHINE:4-40 X 0.250,PNH,STL,CD PL	83385	OBD
-20	210-0004-00			1						.WASHER,LOCK:#4 INTL,0.015 THK,STL CD PL *****END ATTACHING PARTS)*****	000BK	OBD
-21	210-0201-00			1						.TERMINAL,LUG:0.12 ID,LOCKING,BRZ TIN PL *****ATTACHING PARTS)*****	86928	OBD
-22	213-0138-00			1						.SCR,TPG,TF:4-24 X 0.188 INCH,PNH STL *****END ATTACHING PARTS)*****	83385	OBD
-23	-----			1						.TRANSISTOR:(SEE A6A1Q432 REPL) *****ATTACHING PARTS)*****		
-24	211-0514-00			2						.SCREW,MACHINE:6-32 X 0.750 INCH,PNH STL	83385	OBD
-25	210-0561-00			4						.NUT,PLAIN,HEX.:0.188 INCH L,0.188 HEX BRS	80009	210-0561-00
-26	210-0935-00			2						.WASHER,NONMETAL:FIBER,0.14 ID X 0.375"OD *****END ATTACHING PARTS)*****	74921	OBD
-27	386-0978-00			1						.INSULATOR,PLATE:TRANSISTOR,MICA	80009	386-0978-00
-28	214-1713-01			1						.HEAT SINK,XSTR:TO-3,AL	80009	214-1713-01
-29	214-1292-00			1						.HEAT SINK,ELEC:TRANSISTOR	05820	205SB
-30	348-0055-00			1						.GROMMET,PLASTIC:0.25 INCH DIA	80009	348-0055-00
-31	337-2267-00			1						.SHIELD,ELEC:HV TRANSFORMER	80009	337-2267-00
-32	361-0137-00			1						.POST,ELEC-MECH:1.345 INCH,W/4-40 THREAD *****ATTACHING PARTS)*****	80009	361-0137-00
-33	211-0040-00			1						.SCREW,MACHINE:4-40 X 0.25",BDGH PLSTC *****END ATTACHING PARTS)*****	26365	OBD
-34	-----			1						.CKT BOARD ASSY:DISPLAY(SEE A6A1 REPL)		
-35	352-0134-00			1						.HOLDER,COIL:TOROIDAL,0.472 X 0.417 INCH	80009	352-0134-00
-36	214-0506-00			1						.CONTACT,ELEC:0.045 SQ X 0.375 INCH L	80009	214-0506-00
-37	-----			2						TRANSISTOR:(SEE CHASSIS Q1091,Q1092 REPL) *****ATTACHING PARTS)*****		
-38	211-0012-00			2						SCREW,MACHINE:4-40 X 0.375,PNH STL CD PL	83385	OBD
-39	210-1171-00			2						WSHR,SHOULDERED:0.116 ID X 0.138 INCH OD *****END ATTACHING PARTS)*****	52905	A7148516P2
-40	342-0311-00			2						INSULATOR,PLATE:TRANSISTOR,MICA	01295	64-21-023-212

REPLACEABLE MECHANICAL PARTS

Fig. & Index No.	Tektronix Part No.	Serial/Model No. Eff	Dscont	Qty	1	2	3	4	5	Name & Description	Mfr Code	Mfr Part Number
2-41	-----			5						TRANSISTOR:(SEE CHASSIS Q1036,Q1039, Q1044,Q1059,AND Q1067 REPL) ***** (ATTACHING PARTS)*****		
-42	211-0012-00			5						SCREW,MACHINE:4-40 X 0.375,PNH STL CD PL	83385	OBD
-43	210-1171-00			5						WSHR,SHOULDERED:0.116 ID X 0.138 INCH OD ***** (END ATTACHING PARTS)*****	52905	A7148516P2
-44	342-0328-00			1						INSULATOR,PLATE:XSTR,ALUMINUM	80009	342-0328-00
-45	342-0203-00			8						INSULATOR,PLATE:XSTR,0.675 X 0.625 X 0.001	18722	DF103C
-46	-----			4						TRANSISTOR:(SEE CHASSIS Q1069,Q1074, Q1084,AND Q1096 REPL) ***** (ATTACHING PARTS)*****		
-47	211-0507-00			4						SCREW,MACHINE:6-32 X 0.312 INCH,PNH STL ***** (END ATTACHING PARTS)*****	83385	OBD
-48	348-0115-01			1						GROMMET,PLASTIC:U-SHAPED	80009	348-0115-01
-49	255-0334-00			AR						PLASTIC CHANNEL:12.75 X 0.175 X 0.155,NYL	11897	122-37-2500
-50	129-0212-00			2						SPACER,POST:0.312 OD X 0.435 INCH L,NYL ***** (ATTACHING PARTS)*****	80009	129-0212-00
-51	211-0040-00			2						SCREW,MACHINE:4-40 X 0.25",BDGH PLSTC	26365	OBD
-52	211-0008-00			2						SCREW,MACHINE:4-40 X 0.250,PNH,STL,CD PL ***** (END ATTACHING PARTS)*****	83385	OBD
-53	343-0089-00			4						CLAMP,LOOP:LARGE	80009	343-0089-00
-54	366-0261-02			1						KNOB:GRAY,0.129 ID X 0.312 OD X 0.406H	80009	366-0261-02
-55	-----			1						RESISTOR,VAR:(SEE CHASSIS R1050 REPL) ***** (ATTACHING PARTS)*****		
-56	213-0020-00			1						SETSCREW:6-32 X 0.125 INCH,HEX.SOC S ***** (END ATTACHING PARTS)*****	70276	OBD
-57	179-2354-00			1						WIRING HARNESS,:DISPLAY ***** (ATTACHING PARTS)*****	80009	179-2354-00
-58	131-0890-00			4						LOCK,CONNECTOR:4-40 X 0.312 L	71468	D 20418-2
-59	210-0204-00			2						TERMINAL,LUG:0.146 INCH DIA DE,45 DEG BE	78189	2157-06-01-2520N
-60	210-0004-00			8						WASHER,LOCK:#4 INTL,0.015 THK,STL CD PL ***** (END ATTACHING PARTS)*****	000BK	OBD
-61	131-0458-00			1						WIRING HARNESS ASSY INCLUDES: .CONNECTOR,RCPT,:15 PIN,FEMALE (P41)	71468	DA15S
-62	131-1006-00			1						.CONN,RCPT,ELEC:9 CONTACT,FEMALE (P40)	71468	DE 9S
-63	131-0621-00			31						.CONNECTOR,TERM:22-26 AWG,BRS & CU BE GOLD	22526	46231
	131-0622-00			5						.CONTACT,ELEC:0.577"L,28-32 AWG WIRE	22526	46241
	131-0707-00			22						.CONNECTOR,TERM:22-26 AWG,BRS & CU BE GOLD	22526	47439
	131-0708-00			3						.CONTACT,ELEC:0.48"L,28-32 AWG WIRE	22526	47437
	131-0792-00			4						.CONNECTOR,TERM:18-20 AWG,CU BE GOLD PL	22526	46221
-64	352-0197-00			1						.CONN BODY,PL,EL:1 WIRE BLACK	80009	352-0197-00
-65	352-0161-03			1						.CONN BODY,PL,EL:3 WIRE ORANGE	80009	352-0161-03
-66	352-0161-06			1						.CONN BODY,PL,EL:3 WIRE BLUE	80009	352-0161-06
-67	352-0200-00			1						.HLDR,TERM CONN:4 WIRE BLACK	80009	352-0200-00
-68	352-0200-05			1						.CONN BODY,PL,EL:4 WIRE GREEN	80009	352-0200-05
-69	352-0200-06			1						.CONN BODY,PL,EL:4 WIRE BLUE	80009	352-0200-06
-70	352-0203-03			1						.HLDR,TERM CONN:7 WIRE,ORANGE	80009	352-0203-03
-71	352-0204-03			1						.HLDR,TERM CONN:8 WIRE,ORANGE	80009	352-0204-03
-72	352-0204-04			1						.HLDR,TERM CONN:8 WIRE,YELLOW	80009	352-0204-04
-73	352-0205-02			1						.CONN BODY,PL,EL:9 WIRE RED	80009	352-0205-02
-74	352-0205-04			1						.CONN BODY,PL,EL:9 WIRE YELLOW	80009	352-0205-04
-75	352-0428-00			1						.CONN BODY,PLUG:2/12 FEM CONT	22526	65043-070
-76	343-0549-00			20						.STRAP,TIEDOWN:0.091 W X 3.62 INCH LONG	06383	PLT1M
-77	175-0072-00			AR						.CABLE,RF:2 CONDUCTOR	80009	175-0072-00
-78	175-0152-01			AR						.CABLE,SP,ELEC:	80009	175-0152-01
-79	198-3079-00			1						WIRE SET,ELEC:	80009	198-3079-00
-80	204-0678-00			5						.CONN BODY,PL,EL:FOR 3 FEMALE CONTACTS	27264	10-17-2032
-81	131-1815-00			15						.CONTACT,ELEC:22-30 AWG,FEMALE,BRASS	27264	08-56-0110
-82	175-0862-00			AR						.WIRE,ELECTRICAL:3 WIRE RIBBON	08261	SS-0322-1910610C
-83	204-0671-00			4						.CONN BODY,PLUG:1 X 3 CONTACTS NYLON	27264	09-50-7031
-84	131-1790-00			12						.CONTACT,ELEC:18-24 AWG,FEMALE,BRASS	27264	08-56-0105

REPLACEABLE MECHANICAL PARTS

Fig. & Index No.	Tektronix Part No.	Serial/Model No.		Qty	1	2	3	4	5	Name & Description	Mfr	
		Eff	Dscont								Code	Mfr Part Number
2-85	175-0826-00			AR						.WIRE,ELECTRICAL:3 WIRE RIBBON	80009	175-0826-00
-86	441-1291-00			1						CHAS,ELEC EQPT:LEFT *****ATTACHING PARTS*****	80009	441-1291-00
-87	211-0534-00			2						SCR,ASSEM,WSHR:6-32 X 0.312 INCH,PNH STL	83385	OBD
-88	211-0507-00			1						SCREW,MACHINE:6-32 X 0.312 INCH,PNH STL *****END ATTACHING PARTS*****	83385	OBD

REPLACEABLE MECHANICAL PARTS

Fig. & Index No.	Tektronix Part No.	Serial/Model No. Eff	Dscont	Qty	1	2	3	4	5	Name & Description	Mfr Code	Mfr Part Number
3-	----			1						POWER SUPPLY:(SEE A1 REPL) ***** (ATTACHING PARTS)*****		
-1	212-0004-00			7						SCREW,MACHINE:8-32 X 0.312 INCH,PNH STL	83385	OBD
-2	210-0008-00			3						WASHER,LOCK:INTL,0.172 ID X 0.331"OD,S ***** (END ATTACHING PARTS)*****	78189	1208-00-00-0541C
-3	200-2287-00			-						POWER SUPPLY ASSY INCLUDES: .COVER,PWR,SPLY:TOP ***** (ATTACHING PARTS)*****	80009	200-2287-00
-4	211-0507-00			2						SCREW,MACHINE:6-32 X 0.312 INCH,PNH STL ***** (END ATTACHING PARTS)*****	83385	OBD
-5	200-2288-00			1						COVER,PWR,SPLY:BOTTOM ***** (ATTACHING PARTS)*****	80009	200-2288-00
-6	211-0538-00			2						SCREW,MACHINE:6-32 X 0.312"100 DEG,FLH ST ***** (END ATTACHING PARTS)*****	83385	OBD
-7	386-4038-00			1						CKT BOARD ASSY:LINE SEL(SEE A1A1 REPL) ..SUPPORT,XFMR:	80009	386-4038-00
-8	119-1306-00			1						FILTER,RFI:6A,250V,50-400HZ ***** (ATTACHING PARTS)*****	56289	6JX5431A
-9	211-0025-00			2						SCREW,MACHINE:4-40 X 0.375 100 DEG,FLH S	83385	OBD
-10	210-0586-00			2						NUT,PL,ASSEM WA:4-40 X 0.25,STL ***** (END ATTACHING PARTS)*****	83385	OBD
-11	200-1788-01			1						COV,PROT,LINE:	80009	200-1788-01
-12	----			1						XFMR,PWR,SDN&SU:(SEE A1A1T1001 REPL) ***** (ATTACHING PARTS)*****		
-13	212-0515-00			4						SCREW,MACHINE:10-32 X 2.250" HEX.HD STL	83385	OBD
-14	210-0812-00			4						WASHER,NONMETAL:#10,FIBER	86445	OBD
-15	166-0227-00			4						INS SLV,ELEC:0.187 ID X 1.50 INCH LONG	80009	166-0227-00
-16	220-0410-00			4						NUT,EXTENDED WA:10-32 X 0.375 INCH,STL ***** (END ATTACHING PARTS)*****	83385	OBD
-17	200-0237-03			1						COVER,FUSE HLDR:	80009	200-0237-03
-18	200-2264-00			1						CAP.,FUSEHOLDER:3AG FUSES	S3629	FEK 031 1666
-19	204-0832-00			1						BODY,FUSEHOLDER:3AG,5 X 20MM FUSES	S3629	031.1673(MDLFEU)
-20	210-1039-00			1						WASHER,LOCK:INT,0.521 ID X 0.625 INCH O	24931	OBD
-21	210-0202-00			1						TERMINAL,LUG:0.146 ID,LOCKING,BRZ TINNED ***** (ATTACHING PARTS)*****	78189	2104-06-00-2520N
-22	211-0512-00			1						SCREW,MACHINE:6-32 X 0.50" 100 DEG,FLH S	83385	OBD
-23	210-0457-00			2						NUT,PL,ASSEM WA:6-32 X 0.312,STL CD PL ***** (END ATTACHING PARTS)*****	83385	OBD
-24	334-3379-02			1						MARKER,IDENT:MARKED GROUND SYMBOL	80009	334-3379-02
-25	348-0056-00			1						GROMMET,PLASTIC:0.375 INCH DIA	80009	348-0056-00
-26	343-0213-00			1						CLAMP,LOOP:0.2 ID,PLASTIC	80009	343-0213-00
-27	198-4188-00			1						WIRE SET,ELEC:	80009	198-4188-00
-28	175-2301-00			1						CA ASSY,SP,ELEC:4,18 AWG,14.5 L	80009	175-2301-00
-29	131-0947-00			1						CONN BODY,RCPT:MALE,SNAP-IN PNL MT,4 CO	27264	03-09-1041
-30	131-0948-00			4						CONTACT,ELEC:CONNECTOR,BRASS TIN PL	27264	02-09-1103
-31	175-1577-00			AR						CABLE,SP,ELEC:4,18 AWG,TWISTED	80009	175-1577-00
-32	211-0008-00			1						CKT BOARD ASSY:(SEE A1A1A1 REPL) ***** (ATTACHING PARTS)*****		
-33	----			-						CKT BOARD ASSY INCLUDES: ..MICROCIRCUIT:(SEE A1A1A1U1 REPL) ***** (ATTACHING PARTS)*****		
-34	211-0008-00			1						SCREW,MACHINE:4-40 X 0.250,PNH,STL,CD P ***** (END ATTACHING PARTS)*****	83385	OBD
-35	352-0425-00			4						FUSEHOLDER:PLASTIC	80009	352-0425-00
-36	212-0023-00			1						CKT BOARD ASSY:STD REG(SEE A1A2 REPL) ***** (ATTACHING PARTS)*****		
-36	212-0023-00			2						SCREW,MACHINE:8-32 X 0.375,PNH,STL CD PL ***** (END ATTACHING PARTS)*****	83385	OBD

REPLACEABLE MECHANICAL PARTS

Fig. & Index No.	Tektronix Part No.	Serial/Model No.		Qty	1	2	3	4	5	Name & Description	Mfr Code	Mfr Part Number
		Eff	Dscont									
3-	----			-						..CKT BOARD ASSY INCLUDES:		
-37	----			4						..TRANSISTOR:(SEE A1A2Q382,Q482,Q682,AND ..Q782 REPL)		
	----			-					(ATTACHING PARTS)*****		
-38	211-0097-00			4						..SCREW,MACHINE:4-40 X 0.312 INCH,PNH STL	83385	OBD
-39	210-1171-00			4						..WSHR,SHOULDERED:0.116 ID X 0.138 INCH OD	52905	A7148516P2
	----			-					(END ATTACHING PARTS)*****		
-40	342-0203-00			4						..INSULATOR,PLATE:XSTR,0.675 X 0.625 X 0.0	18722	DF103C
-41	----			1						..CKT BOARD ASSY:(SEE A1A2A2 REPL)		
	----			-					(ATTACHING PARTS)*****		
-42	211-0008-00			7						..SCREW,MACHINE:4-40 X 0.250,PNH,STL,CD PL	83385	OBD
	----			-					(END ATTACHING PARTS)*****		
	----			-						..CKT BOARD ASSY INCLUDES:		
-43	344-0154-00			8						...CLIP,ELECTRICAL:FUSE,CKT BD MT	80009	344-0154-00
-44	334-2151-00			1						...MARKER,IDENT:MKD DANGER 365 V	80009	334-2151-00
-45	----			1						..TRANSISTOR:(SEE A1A2A2Q741 REPL)		
	----			-					(ATTACHING PARTS)*****		
-46	211-0097-00			1						...SCREW,MACHINE:4-40 X 0.312 INCH,PNH STL	83385	OBD
-47	210-0586-00			1						...NUT,PL,ASSEM WA:4-40 X 0.25,STL	83385	OBD
	----			-					(END ATTACHING PARTS)*****		
-48	211-0001-00			2						..SCREW,MACHINE:2-56 X 0.25 INCH,PNH STL	87308	OBD
-49	342-0426-00			1						..INSULATOR,FILM:HEAT SINK,PLASTIC	80009	342-0426-00
-50	342-0424-00			1						..INSULATOR,FILM:HEAT SINK,PLASTIC	55285	OBD
-51	385-0012-00			4						..SPACER,POST:0.312 OD,0.562 L W/8-32 THD	80009	385-0012-00
-52	175-2499-00			1						..CA ASSY,SP,ELEC:2,22 AWG,8.5 L	80009	175-2499-00
-53	204-0678-00			1						...CONN BODY,PL,EL:FOR 3 FEMALE CONTACTS	27264	10-17-2032
-54	204-0826-00			1						...CONN BODY,RCPT:2 CONT,FEMALE	27264	03-09-1021
-55	131-1815-00			2						...CONTACT,ELEC:22-30 AWG,FEMALE,BRASS	27264	08-56-0110
-56	131-0948-00			2						...CONTACT,ELEC:CONNECTOR,BRASS TIN PL	27264	02-09-1103
-57	----			1						..CKT BOARD ASSY:(SEE A1A2A1 REPL)		
	----			-					(ATTACHING PARTS)*****		
-58	211-0008-00			6						..SCREW,MACHINE:4-40 X 0.250,PNH,STL,CD PL	83385	OBD
	----			-					(END ATTACHING PARTS)*****		
	----			-						..CKT BOARD ASSY INCLUDES:		
-59	361-0909-00			1						...SPACER,PLATE:0.562 X 1.3 X 1.25 AL	80009	361-0909-00
	----			-					(ATTACHING PARTS)*****		
-60	211-0008-00			2						...SCREW,MACHINE:4-40 X 0.250,PNH,STL,CD P	83385	OBD
	----			-					(END ATTACHING PARTS)*****		
-61	361-0908-00			1						...SPACER,PLATE:0.562 X 2.4 X 1.0 AL	80009	361-0908-00
	----			-					(ATTACHING PARTS)*****		
-62	211-0008-00			2						...SCREW,MACHINE:4-40 X 0.250,PNH,STL,CD P	83385	OBD
	----			-					(END ATTACHING PARTS)*****		
-63	342-0425-00			1						..INSULATOR,FILM:TRANSISTOR,PLASTIC	80009	342-0425-00
-64	386-3928-00			1						..SUPPORT,XSTR:	80009	386-3928-00
	----			-					(ATTACHING PARTS)*****		
-65	211-0008-00			2						...SCREW,MACHINE:4-40 X 0.250,PNH,STL,CD P	83385	OBD
	----			-					(END ATTACHING PARTS)*****		
-66	342-0389-00			2						..INSULATOR,PLATE:TRANSISTOR,PLASTIC	80009	342-0389-00
-67	136-0252-07			9						...SOCKET,PIN CONN:W/O DIMPLE	22526	75060-012
-68	----			2						...DIODE:(SEE A1A2A1CR371 & CR381 REPL)		
	----			-					(ATTACHING PARTS)*****		
-69	210-0224-00			2						...TERMINAL,LUG:0.20 ID X 0.344 OD,SE,BRS	86928	A373-148-1
-70	210-0010-00			2						...WASHER,LOCK:INT,0.20 ID X 0.376" OD,STL	78189	1210-00-00-0541C
	----			-					(END ATTACHING PARTS)*****		
-71	346-0128-00			1						...STRAP,TIE DOWN:0.1W X 8.0" LONG,NYLON	06383	PLT2M
-72	175-2436-00			1						...CA ASSY,SP,ELEC:2,26 AWG,2,18 AWG,7.25	80009	175-2436-00
-73	175-0072-00			AR						...CABLE,RF:2 CONDUCTOR	80009	175-0072-00
-74	354-0538-00			1						...PACKING,PREFMD:0.119 ID X 0.125" OD,NPR	07322	8006-366Y
-75	162-0561-00			AR						..INSUL SLVG,ELEC:HT SHRINK,0.093,POLYOLE	06090	VERSAFIT
-76	----			1						...FERRITE:(SEE A1A2A1T1003 REPL)		
-77	441-1457-00			1						...CHASSIS,CKT BD:	80009	441-1457-00
-78	----			1						...RESISTOR:(SEE A1A2A1R1003 REPL)		
-79	175-2300-00			1						..CA ASSY,SP,ELEC:10,22 AWG,8.0 L	80009	175-2300-00
-80	352-0462-00			2						..HLDR,TERM. CONN:10 FEMALE,NYLON	27264	09-50-7101
-81	131-1790-00			20						..CONTACT,ELEC:18-24 AWG,FEMALE,BRASS	27264	08-56-0105
-82	175-5061-00			AR						..CABLE,SP,ELEC:10,18 AWG,RIBBON	08261	SS101819(1007)-X

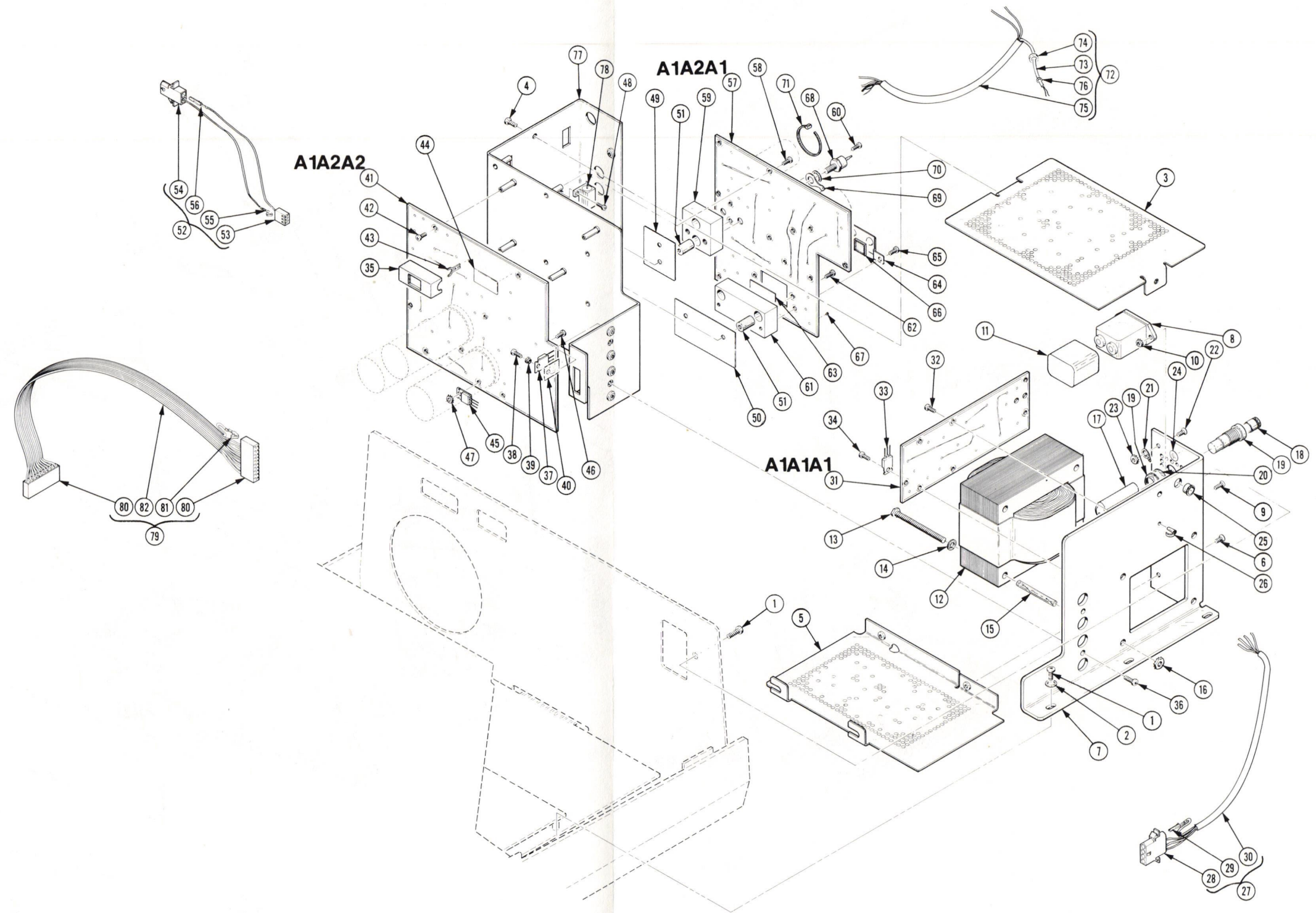
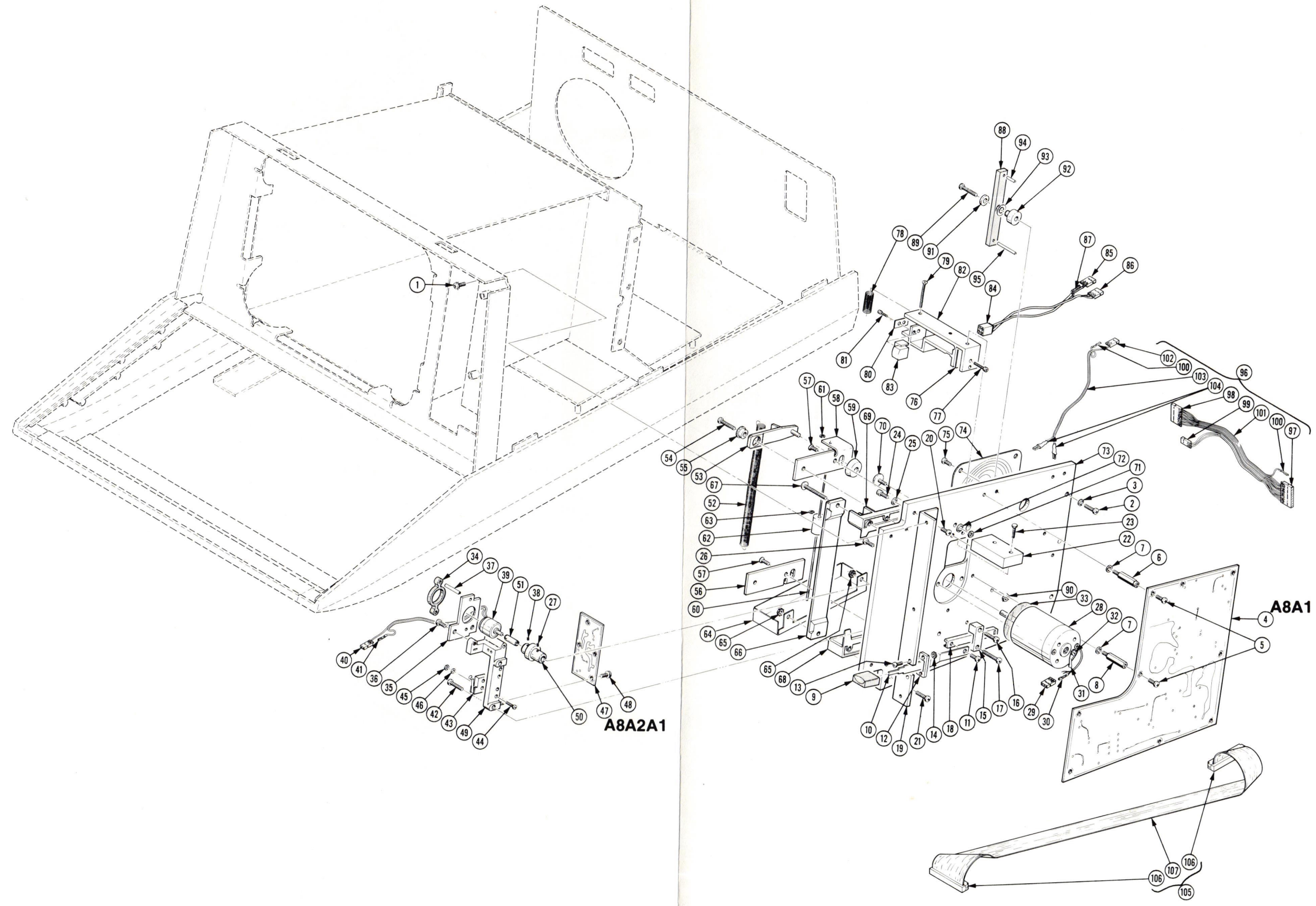

FIG. 3 POWER SUPPLY

ADD JUL 1982

4052/4052A PARTS AND SCHEMATICS



REPLACEABLE MECHANICAL PARTS

Fig. & Index No.	Tektronix Part No.	Serial/Model No.		Qty	1	2	3	4	5	Name & Description	Mfr Code	Mfr Part Number
		Eff	Dscont									
4-	-----			1						DRIVE,MAG TAPE:(SEE A8 REPL) *****ATTACHING PARTS)*****		
-1	211-0534-00			2						SCR,ASSEM,WSHR:6-32 X 0.312 INCH,PNH STL	83385	OBD
-2	211-0551-00			3						SCREW,MACHINE:6-32 X 0.562 INCH,PNH STL	83385	OBD
-3	210-0006-00			3						WASHER,LOCK:#6 INTL,0.018 THK,STL CD PL *****END ATTACHING PARTS)*****	78189	1206-00-00-0541C
-4	-----			1						DRIVE,MAG TAPE ASSY INCLUDES: .CKT BOARD ASSY:TAPE DRIVER(SEE A8A1 REPL) *****ATTACHING PARTS)*****		
-5	211-0507-00			8						.SCREW,MACHINE:6-32 X 0.312 INCH,PNH STL *****END ATTACHING PARTS)*****	83385	OBD
-6	129-0539-00			7						.POST,ELEC-MECH:6-32 THD EXT/INT,1.250 L	80009	129-0539-00
-7	210-0055-00			8						.WASHER,LOCK:SPLIT,0.145 ID X 0.253 OD,S	83385	OBD
-8	129-0295-00			1						.SPACER,POST:0.250 HEX X 0.894 INCH L,AL	80009	129-0295-00
-9	366-1629-01			1						.PUSH BUTTON:GRAY,EJECT	80009	366-1629-01
-10	214-2316-00			1						.LVR,CRTG EJECT:4.875 L,ALUMINUM *****ATTACHING PARTS)*****	80009	214-2316-00
-11	213-0054-00			1						.SCR,TPG,THD FOR:6-32 X 0.312 INCH,PNH STL *****END ATTACHING PARTS)*****	93907	OBD
-12	351-0455-00			1						.GUIDE,LEVER:EJECT *****ATTACHING PARTS)*****	80009	351-0455-00
-13	211-0012-00			2						.SCREW,MACHINE:4-40 X 0.375,PNH STL CD PL	83385	OBD
-14	210-0586-00			2						.NUT,PL,ASSEM WA:4-40 X 0.25,STL *****END ATTACHING PARTS)*****	83385	OBD
-15	391-0139-00			2						.BLOCK,GUIDE:CARTRIDGE EJEC *****ATTACHING PARTS)*****	80009	391-0139-00
-16	211-0513-00			2						.SCREW,MACHINE:6-32 X 0.625 INCH,PNH STL	83385	OBD
-17	211-0516-00			2						.SCREW,MACHINE:6-32 X 0.875 INCH,PNH STL *****END ATTACHING PARTS)*****	83385	OBD
-18	381-0365-00			2						.BAR,CRTG EJECT:DELRIN	80009	381-0365-00
-19	407-1697-00			1						.BRACKET,ANGLE:TAPE DECK,ALUMINUM *****ATTACHING PARTS)*****	80009	407-1697-00
-20	211-0510-00			1						.SCREW,MACHINE:6-32 X 0.375,PNH,STL,CD PL	83385	OBD
-21	211-0513-00			1						.SCREW,MACHINE:6-32 X 0.625 INCH,PNH STL *****END ATTACHING PARTS)*****	83385	OBD
-22	391-0144-01			1						.BLOCK,SUPPORT:HEAD ALIGNMENT *****ATTACHING PARTS)*****	80009	391-0144-01
-23	211-0588-00			2						.SCREW,MACHINE:6-32 X 0.75 INCH,HEX.HD STL	83385	OBD
-24	211-0564-00			2						.SCREW,CAP,SCH:6-32 X 0.375" L HEX	80009	211-0564-00
-25	210-0803-00			2						.WASHER,FLAT:0.15 ID X 0.032 THK,STL CD *****END ATTACHING PARTS)*****	12327	OBD
	-----			1						.MOTOR,DC:(SEE A8B1092 REPL) *****ATTACHING PARTS)*****		
-26	211-0507-00			2						.SCREW,MACHINE:6-32 X 0.312 INCH,PNH STL	83385	OBD
-27	213-0228-01			1						.SETSCREW:6-32 X 0.125,STL,CD PL,HEX *****END ATTACHING PARTS)*****	000CY	OBD
	-----			-						.MOTOR ASSY INCLUDES:		
-28	147-0046-00			1						.MOTOR,DC:TAPE DRIVE,12V	98938	9213
-29	352-0161-05			1						.CONN BODY,PL,EL:3 WIRE GREEN	80009	352-0161-05
-30	131-0707-00			3						.CONNECTOR,TERM:22-26 AWG,BRS & CU BE GOL	22526	47439
-31	210-0203-00			1						.TERMINAL,LUG:SE #6 *****ATTACHING PARTS)*****	78189	2103-06-00-2520N
-32	213-0124-00			1						.SCR,TPG,THD FOR:6-20 X 0.250 INCH,PNH ST *****END ATTACHING PARTS)*****	83385	OBD
-33	361-0747-00			1						.SPACER,PLATE:0.562 ID X 0.02 THK	80009	361-0747-00
-34	352-0424-00			1						.HOLDER,TACH:SILCONE RUBBER	80009	352-0424-00
-35	386-3369-01			1						.PLATE,TACH: *****ATTACHING PARTS)*****	80009	386-3369-01
-36	211-0507-00			2						.SCREW,MACHINE:6-32 X 0.312 INCH,PNH STL *****END ATTACHING PARTS)*****	83385	OBD
-37	214-1474-00			2						.PIN,SPRING:0.75 L X 0.135 OD,CS BLACK	22599	59-028-125-0750
	-----			1						.MOTOR,DC:(SEE A8B1090 REPL) *****ATTACHING PARTS)*****		
-38	213-0228-01			1						.SETSCREW:6-32 X 0.125,STL,CD PL,HEX *****END ATTACHING PARTS)*****	000CY	OBD

REPLACEABLE MECHANICAL PARTS

Fig. & Index No.	Tektronix Part No.	Serial/Model No. Eff	Dscont	Qty	1 2 3 4 5	Name & Description	Mfr Code	Mfr Part Number
4-	-----			-		.MOTOR ASSY INCLUDES:		
-39	147-0045-00			1		..MOTOR,DC:6V,17,000 RPM	50778	16C14-207-9
-40	352-0169-04			1		..CONN BODY,PL,EL:2 WIRE YELLOW	80009	352-0169-04
-41	131-0707-00			2		..CONNECTOR,TERM:22-26 AWG,BRS & CU BE GOL	22526	47439
	-----			1		.CKT BOARD ASSY:STATUS W/MICRO SW		
	-----			-		.(SEE A8A2 REPL)		
					(ATTACHING PARTS).....		
-42	211-0513-00			2		.SCREW,MACHINE:6-32 X 0.625 INCH,PNH STL	83385	OBD
	-----			-	(END ATTACHING PARTS).....		
						.CKT BOARD ASSY INCLUDES:		
-43	-----			2		..SWITCH,PUSH:(SEE A8A2S1,S2 REPL)		
					(ATTACHING PARTS).....		
-44	211-0034-00			4		..SCREW,MACHINE:2-56 X 0.50 INCH,PNH	83385	OBD
-45	210-0405-00			4		..NUT,PLAIN,HEX.:2-56 X 0.188 INCH,BRS	73743	12157-50
-46	210-0001-00			4		..WASHER,LOCK:INTL,0.092 ID X 0.18"OD,ST	78189	1202-00-00-0541C
					(END ATTACHING PARTS).....		
-47	-----			1		.CKT BOARD ASSY:(SEE A8A2A1 REPL)		
					(ATTACHING PARTS).....		
-48	211-0601-00			2		..SCR,ASSEM WSHR:6-32 X 0.312,DOUBLE SEMS	83385	OBD
					(END ATTACHING PARTS).....		
-49	-----			1		..BRKT,SENSOR MTG:POLYCARBONATE		
-50	401-0342-04			1		.HUB,TAPE DRIVE:W/0.645 DIA HYPALON WHEEL	80009	401-0342-04
-51	214-2419-00			1		.PIN,SPRING:0.5 L X 0.188 OD,AL	80009	214-2419-00
-52	214-2261-00			1		.SPRING,HLCPS:0.035 DIA,5.5 L MUSIC WIRE	80009	214-2261-00
-53	214-2264-00			2		.ARM,DETENT:TAPE POSITIONING	80009	214-2264-00
					(ATTACHING PARTS).....		
-54	211-0514-00			2		.SCREW,MACHINE:6-32 X 0.750 INCH,PNH STL	83385	OBD
-55	343-0551-00			2		.RTNR,DETENT ARM:0.14 ID X 0.373 OD,AL	80009	343-0551-00
					(END ATTACHING PARTS).....		
-56	351-0451-00			1		.GUIDE,TAPE CRTG:TOP LEFT	80009	351-0451-00
					(ATTACHING PARTS).....		
-57	211-0522-00			1		.SCREW,MACHINE:6-32 X 0.625 FLH,100 DEG ST	83385	OBD
					(END ATTACHING PARTS).....		
-58	351-0462-00			1		.GUIDE,TAPE CRTG:TOP RIGHT	80009	351-0462-00
					(ATTACHING PARTS).....		
	211-0522-00			1		.SCREW,MACHINE:6-32 X 0.625 FLH,100 DEG ST	83385	OBD
					(END ATTACHING PARTS).....		
-59	214-2263-00			2		.WHEEL,DETENT:0.187 ID X 0.6 OD,SST	80009	214-2263-00
-60	384-1383-00			1		.SHAFT,HOLDDOWN:0.093 DIA X 7.66 L,STL	80009	384-1383-00
					(ATTACHING PARTS).....		
-61	354-0350-00			2		.RING,RETAINING:0.073"FREE ID X 0.015",ST	79136	5133-9MD
					(END ATTACHING PARTS).....		
-62	401-0349-00			1		.ROLLER,HOLDDOWN:0.50 DIA X 0.75 L,NYLON	80009	401-0349-00
					(ATTACHING PARTS).....		
-63	354-0554-00			2		.RING,RETAINING:EXT LUG GRIPPING,0.094 D	79136	G5555-9
					(END ATTACHING PARTS).....		
-64	337-2260-00			1		.SHIELD:TRAY,SAFETY	80009	337-2260-00
					(ATTACHING PARTS).....		
-65	210-0457-00			2		.NUT,PL,ASSEM WA:6-32 X 0.312,STL CD PL	83385	OBD
					(END ATTACHING PARTS).....		
-66	351-0629-00			1		.GUIDE,TAPE CRTG:ENTRANCE	80009	351-0629-00
					(ATTACHING PARTS).....		
-67	211-0545-00			2		.SCREW,MACHINE:6-32 X 1.250 INCH,TRH STL	83385	OBD
					(END ATTACHING PARTS).....		
-68	351-0454-00			1		.GUIDE,TAPE CRTG:LEFT	80009	351-0454-00
-69	351-0453-00			1		.GUIDE,TAPE CRTG:RIGHT	80009	351-0453-00
-70	361-0781-00			2		.SPACER,PAD:W/4-40 THD	80009	361-0781-00
					(ATTACHING PARTS).....		
-71	210-0407-00			2		.NUT,PLAIN,HEX.:6-32 X 0.25 INCH,BRS	73743	3038-0228-402
-72	210-0006-00			2		.WASHER,LOCK:#6 INTL,0.018 THK,STL CD PL	78189	1206-00-00-0541C
					(END ATTACHING PARTS).....		
-73	386-3368-01			1		.PLATE,TAPE DECK:	80009	386-3368-01
-74	-----			1		.LOUDSPEAKER,PM:(SEE A8LS60 REPL)		
					(ATTACHING PARTS).....		
-75	211-0507-00			4		.SCREW,MACHINE:6-32 X 0.312 INCH,PNH STL	83385	OBD
					(END ATTACHING PARTS).....		

REPLACEABLE MECHANICAL PARTS

Fig. & Index No.	Tektronix Part No.	Serial/Model No.		Qty	1	2	3	4	5	Name & Description	Mfr Code	Mfr Part Number
		Eff	Dscont									
4-76	386-3554-00			1						.PLATE,PROT:HEAD ALIGNMENT ***** (ATTACHING PARTS) *****	80009	386-3554-00
-77	211-0164-00			1						.SCREW,CAP,SCH:4-40 X 0.625 INCH,L STL	83385	OBD
	211-0093-00			1						.SCR,CAP,SOC HD:4-40 X 0.75 INCH L,STL ***** (END ATTACHING PARTS) *****	000BK	OBD
-78	214-2430-00			1						.SPRING,HLCPS:0.375 OD X 1.5 L,OPEN ENDS ***** (ATTACHING PARTS) *****	000AE	C36C
-79	211-0248-00			1						.SCREW,CAP,SCH:4-40 X 1.25 FLH,82 DEG,STL ***** (END ATTACHING PARTS) *****	000AH	OBD
-80	386-2823-00			1						.PL,MTG,TAPE HD: ***** (ATTACHING PARTS) *****	80009	386-2823-00
-81	211-0206-00			2						.SCR,CAP,SOC HD:2-56 X 0.312 INCH,STL ***** (END ATTACHING PARTS) *****	000AH	OBD
-82	352-0450-01			1						.HLDR,HEAD ALIGN:ALUMINUM	80009	352-0450-01
-83	-----			1						.HEAD,SRR:(SEE A8PU1001 REPL)		
	119-0421-03			1						.HEAD,SRR:	80009	119-0421-03
-84	119-0421-01			1						..HEAD,SRR CABLE:	11983	139077
-85	352-0161-08			1						..CONN BODY,PL,EL:3 WIRE GRAY	80009	352-0161-08
-86	352-0161-09			1						..CONN BODY,PL,EL:3 WIRE WHITE	80009	352-0161-09
-87	131-0707-00			6						..CONNECTOR,TERM:22-26 AWG,BRS & CU BE GOL	22526	47439
-88	214-2319-00			1						.BAR,PIVOT:CARTRIDGE EJECT ***** (ATTACHING PARTS) *****	80009	214-2319-00
-89	211-0517-00			1						.SCREW,MACHINE:6-32 X 1 INCH,PNH,STL	83385	OBD
-90	210-0457-00			1						.NUT,PL,ASSEM WA:6-32 X 0.312,STL CD PL	83385	OBD
-91	210-0803-00			1						.WASHER,FLAT:0.15 ID X 0.032 THK,STL CD	12327	OBD
-92	214-2320-00			1						.PVT,CRTG EJCTR:0.5 DIA,DELRIN	80009	214-2320-00
-93	210-0992-00			1						.WASHER,FLAT:0.265 ID X 0.01 THK,TEFLON ***** (END ATTACHING PARTS) *****	80009	210-0992-00
-94	214-2351-00			1						..PIN,SPRING:0.375" L X 0.101" OD,STL	22599	52-022-094-0375
-95	214-1534-00			1						..PIN,RETAINING:1.25 L X 0.103 OD,CS BLACK	22599	59-022-094-1250
-96	198-0725-00			1						.WIRE SET,ELEC:	80009	198-0725-00
-97	352-0167-07			1						..CONN BODY,PL,EL:9 WIRE VIOLET	80009	352-0167-07
-98	352-0165-00			1						..CONN BODY,PL,EL:7 WIRE BLACK	80009	352-0165-00
-99	352-0169-00			1						..HLDR,TERM CONN:2 WIRE BLACK	80009	352-0169-00
-100	131-0707-00			20						..CONNECTOR,TERM:22-26 AWG,BRS & CU BE GOL	22526	47439
-101	175-0832-00			AR						..WIRE,ELECTRICAL:9 WIRE RIBBON	08261	SS-0926(1061)OC
-102	352-0169-01			1						..HLDR TERM CONN:2 WIRE,BROWN	80009	352-0169-01
-103	175-0863-00			AR						..WIRE,ELECTRICAL:2 WIRE RIBBON	08261	SS-0222-7(1061)
-104	131-2512-00			2						..TERM, QIK DISC:24-20 AWG,BRASS TIN PLATED ..(SPEAKER CONNECTORS)	00779	62138-1
-105	175-2123-00			1						CA ASSY,SP,ELEC:34,28 AWG,19.25 L	80009	175-2123-00
-106	131-0833-01			2						.CONNECTOR,PLUG.:0.750 FT LONG	53387	3414
-107	175-1084-00			AR						.WIRE,ELECTRICAL:FLAT TYPE,3 INCHES LONG	53387	75037

REPLACEABLE MECHANICAL PARTS

Fig. & Index No.	Tektronix Part No.	Serial/Model No.		Qty	Name & Description					Mfr Code	Mfr Part Number
		Eff	Dscont		1	2	3	4	5		
5-1	407-0997-00			2	BRACKET,ANGLE:IMPLOSION SHLD RTNR,AL ***** (ATTACHING PARTS) *****					80009	407-0997-00
-2	211-0008-00			4	SCREW,MACHINE:4-40 X 0.250,PNH,STL,CD PL ***** (END ATTACHING PARTS) *****					83385	OBD
-3	253-0056-00			AR	CUSHION:POLYURETHANE FOAM,PRESSURE					04963	4116
-4	337-1482-00			1	FILTER,LT,CRT:					80009	337-1482-00
-5	426-0834-01			1	FR,IMPLOSION SH: ***** (ATTACHING PARTS) *****					80009	426-0834-01
-6	212-0553-00			4	SCREW,MACHINE:10-32 X 1.50 INCH,PNH STL					83385	OBD
-7	361-0541-00			4	SPACER,SLEEVE:0.50 OD X 0.976 INCH LONG ***** (END ATTACHING PARTS) *****					80009	361-0541-00
-8	131-1385-00			4	CONTACT,ELEC:GROUNDING					80009	131-1385-00
-9	210-0632-00			8	EYELET,METALLIC:0.089 OD X 0.125" LONG,BRS					01881	3168
-10	378-0064-00			1	FILTER,LIGHT:6.276 X 1.0,0.06 R ACRYLIC ***** (ATTACHING PARTS) *****					80009	378-0064-00
-11	211-0017-00			2	SCREW,MACHINE:4-40 X 0.375 INCH,PNH STL ***** (END ATTACHING PARTS) *****					83385	OBD
-12	-----			1	CKT BOARD ASSY:INDICATOR LIGHT(SEE A9 REPL						
-13	337-2235-00			2	.SHIELD,LIGHT:CKT CD MT,1.0 X 0.355 INCH					80009	337-2235-00
-14	361-0751-00			2	.SPACER,SLEEVE:0.156 ID X 0.312 OD X 0.493					80009	361-0751-00
-15	-----			1	ELECTRON TUBE:CRT(SEE CHASSIS V1 REPL)						
-16	354-0316-01			1	.RING,CRT MTG:NEOPRENE					80009	354-0316-01
-17	344-0294-00			1	CLIP,GROUND:BRN SATIN NICKEL PL					80009	344-0294-00
-18	343-0628-00			1	RETAINER,CLIP:GROUNDING,AL					80009	343-0628-00
-19	211-0008-00			1	SCREW,MACHINE:4-40 X 0.250,PNH,STL,CD PL					83385	OBD
-20	386-3367-00			1	SUPPORT,CRT:FRONT ***** (ATTACHING PARTS) *****					80009	386-3367-00
-21	212-0004-00			2	SCREW,MACHINE:8-32 X 0.312 INCH,PNH STL					83385	OBD
-22	210-0008-00			2	WASHER,LOCK:INTL,0.172 ID X 0.331"OD,S ***** (END ATTACHING PARTS) *****					78189	1208-00-00-0541C
-23	129-0569-00			2	POST,ELEC-MECH:0.543 L,W/4-40 THD,AL					80009	129-0569-00
-24	343-0298-00			1	CLAMP,LOOP:PLASTIC,W/ADHESIVE BACK					95987	HPC25
-25	386-3420-00			1	STIFFENER,CHAS:DISPLAY ***** (ATTACHING PARTS) *****					80009	386-3420-00
-26	211-0097-00			3	SCREW,MACHINE:4-40 X 0.312 INCH,PNH STL ***** (END ATTACHING PARTS) *****					83385	OBD
-27	334-1379-00			1	LABEL:CRT,ADHESIVE BACK					80009	334-1379-00
-28	348-0115-01			1	GROMMET,PLASTIC:U-SHAPED					80009	348-0115-01
-29	343-0006-00			1	CLAMP,LOOP:0.50 INCH DIAMETER,PLSTC ***** (ATTACHING PARTS) *****					95987	1-2-6B
-30	211-0014-00			1	SCREW,MACHINE:4-40 X 0.50 INCH,PNH STL					83385	OBD
-31	210-0994-00			1	WASHER,FLAT:0.125 ID X 0.25" OD,STL					86928	5702-201-20
-32	210-0863-00			1	WSHR,LOOP CLAMP:0.187 ID U/W 0.5 W CLP,STL ***** (END ATTACHING PARTS) *****					95987	C191
-33	348-0013-00			4	FOOT,CABINET:BLACK RUBBER					70485	1561
-34	337-1519-00			1	SHLD,ELCTR N TUB:FRONT ***** (ATTACHING PARTS) *****					80009	337-1519-00
-35	211-0590-00			4	SCREW,MACHINE:6-32 X 0.250,PNH,BRS,CD PL ***** (END ATTACHING PARTS) *****					83385	OBD
-36	343-0089-00			2	CLAMP,LOOP:LARGE					80009	343-0089-00
-37	343-0213-00			2	CLAMP,LOOP:0.2 ID,PLASTIC					80009	343-0213-00
-38	255-0334-00			AR	PLASTIC CHANNEL:12.75 X 0.175 X 0.155,NYL					11897	122-37-2500
-39	386-3349-01			1	SUPPORT,CRT:CENTER ***** (ATTACHING PARTS) *****					80009	386-3349-01
-40	212-0004-00			2	SCREW,MACHINE:8-32 X 0.312 INCH,PNH STL					83385	OBD
-41	210-0008-00			2	WASHER,LOCK:INTL,0.172 ID X 0.331"OD,S ***** (END ATTACHING PARTS) *****					78189	1208-00-00-0541C
-42	407-1749-00			1	BRACKET,YOKE:ALUMINUM ***** (ATTACHING PARTS) *****					80009	407-1749-00
-43	211-0581-00			2	SCREW,MACHINE:6-32 X 0.375 INCH,TRH STL					83385	OBD
-44	210-0006-00			2	WASHER,LOCK:#6 INTL,0.018 THK,STL CD PL ***** (END ATTACHING PARTS) *****					78189	1206-00-00-0541C
-45	358-0561-00			1	BUSHING,SLEEVE:1.15 ID X 2.0 L,SI,1.2 OD					80009	358-0561-00
-46	119-0745-00			1	COIL,TUBE DEFL:					80009	119-0745-00

REPLACEABLE MECHANICAL PARTS

Fig. & Index No.	Tektronix Part No.	Serial/Model No.		Qty	Name & Description	Mfr	
		Eff	Dscont			Code	Mfr Part Number
5-47	337-2263-00			1	SHLD,ELECTRON T:REAR ***** (ATTACHING PARTS) *****	80009	337-2263-00
-48	210-0458-00			2	NUT,PL,ASSEM WA:8-32 X 0.344 INCH,STL ***** (END ATTACHING PARTS) *****	83385	OBD
-49	198-2604-00			1	WIRE SET,ELEC:	80009	198-2604-00
-50	131-0621-00			4	.CONNECTOR,TERM:22-26 AWG,BRS & CU BE GOLD	22526	46231
-51	352-0198-01			1	.HLDR,TERM CONN:2 WIRE BROWN	80009	352-0198-01
-52	380-0332-01			1	HSG,FAN GUARD:ABS ***** (ATTACHING PARTS) *****	80009	380-0332-01
-53	211-0514-00			4	SCREW,MACHINE:6-32 X 0.750 INCH,PNH STL	83385	OBD
-54	210-0457-00			4	NUT,PL,ASSEM WA:6-32 X 0.312,STL CD PL ***** (END ATTACHING PARTS) *****	83385	OBD
-55	200-2222-00			2	GUARD,FAN: ***** (ATTACHING PARTS) *****	81041	6-182-033
-56	211-0551-00			4	SCREW,MACHINE:6-32 X 0.562 INCH,PNH STL	83385	OBD
-57	210-0457-00			4	NUT,PL,ASSEM WA:6-32 X 0.312,STL CD PL ***** (END ATTACHING PARTS) *****	83385	OBD
-58	119-0721-00			1	FAN,VENTILATING:75 CFM,7W,115VAC,50/60HZ	80009	119-0721-00
-59	175-2501-00			1	CA ASSY,SP,ELEC:2,18 AWG,4.5 L	80009	175-2501-00
-60	131-0945-00			2	.CONTACT,ELEC:CONNECTOR,BRASS TIN PL	27264	02-09-2101
-61	204-0827-00			1	.CONN BODY,PLUG:2 CONT FEMALE	27264	03-09-2022
-62	175-2203-00			AR	.CABLE,SP,ELEC:2,18 AWG,W/VINYL JACKET	80009	175-2203-00
-63	131-2436-00			2	.TERM, QIK DISC:18-22 AWG,FEMALE	00779	2-520083-2
-64	386-4052-00			1	SUPPORT,CKT BD:RIGHT ***** (ATTACHING PARTS) *****	80009	386-4052-00
-65	211-0514-00			5	SCREW,MACHINE:6-32 X 0.750 INCH,PNH STL	83385	OBD
-66	211-0538-00			8	SCREW,MACHINE:6-32 X 0.312*100 DEG,FLH ST ***** (END ATTACHING PARTS) *****	83385	OBD
-67	386-4053-00			1	SUPPORT,CKT BD:LEFT ***** (ATTACHING PARTS) *****	80009	386-4053-00
-68	211-0514-00			5	SCREW,MACHINE:6-32 X 0.750 INCH,PNH STL	83385	OBD
-69	211-0538-00			8	SCREW,MACHINE:6-32 X 0.312*100 DEG,FLH ST ***** (END ATTACHING PARTS) *****	83385	OBD
-70	-----			1	CKT BOARD ASSY:ALU(SEE A2 REPL)		
-71	136-0634-00			3	.SOCKET,PLUG-IN:20 LEAD DIP,CKT BD MTG	73803	CS9002-20
	136-0752-00			1	.SKT,PL-IN ELEK:MICROCIRCUIT,20 DIP	09922	DILB20P-108
-72	136-0751-00			7	.SKT,PL-IN ELEK:MICROCKT,24 PIN	09922	DILB24P108
-73	129-0753-00			1	.SPACER,POST:0.413 L,W/6-32 THRU THD,BRS ***** (ATTACHING PARTS) *****	80009	129-0753-00
-74	200-2486-00			1	.CAP,INSULATING:0.187 OD,BLACK,VINYL ***** (END ATTACHING PARTS) *****	15819	.187-4 TRIMLINE
-75	361-0562-00			5	.SPACER,SLEEVE:0.156 ID X 0.25 OD X 0.375	80009	361-0562-00
-76	129-0750-00			2	.SPACER,POST:1.073 L,W/6-32 THD EA END,A	80009	129-0750-00
-77	136-0729-00			3	.SKT,PL-IN ELEK:MICROCKT,16 CONTACT	09922	DILB16P-108T
-78	-----			2	.CONN,RCPT,ELEC:(SEE A2J201A,,J201B REPL)		
-79	131-0993-00			1	.BUS,CONDUCTOR:2 WIRE BLACK	00779	850100-01
-80	-----			1	CKT BOARD ASSY:MCP(SEE A3 REPL)		
-81	-----			1	.CONN,RCPT,ELEC:(SEE A3J20 REPL)		
-82	131-2448-00			1	.TERM SET,PIN:7 MALE CONTACTS	27264	09-61-1071
-83	361-0562-00			8	.SPACER,SLEEVE:0.156 ID X 0.25 OD X 0.375	80009	361-0562-00
-84	129-0753-00			2	.SPACER,POST:0.413 L,W/6-32 THRU THD,BRS ***** (ATTACHING PARTS) *****	80009	129-0753-00
-85	211-0558-00			2	.SCREW,MACHINE:6-32 X 0.250 BDGH,NYL,SLOT ***** (END ATTACHING PARTS) *****	26365	921-1150-0014
-86	131-1465-00			2	.CONNECTOR,RCPT,:34 RT ANGEL CONT ***** (ATTACHING PARTS) *****	20999	3431-1002
-87	211-0159-00			4	.SCREW,MACHINE:2-56 X 0.375 INCH,PNH STL	87308	OBD
-88	210-0405-00			4	.NUT,PLAIN,HEX.:2-56 X 0.188 INCH,BRS ***** (END ATTACHING PARTS) *****	73743	12157-50
-89	-----			1	CKT BOARD ASSY:MAS(SEE A4 REPL)		
-90	136-0729-00			19	.SKT,PL-IN ELEK:MICROCKT,16 CONTACT	09922	DILB16P-108T
-91	131-0993-00			3	.BUS,CONDUCTOR:2 WIRE BLACK	00779	850100-01

REPLACEABLE MECHANICAL PARTS

Fig. & Index No.	Tektronix Part No.	Serial/Model No. Eff Dscont	Qty	1 2 3 4 5	Name & Description	Mfr Code	Mfr Part Number
5-92	136-0694-00		2		.SKT,PL-IN ELEK:MICROCIRCUIT,28 CONTACT	73803	CS9002-28
-93	129-0747-00		8		.SPACER POST:0.633 L,W/6-32 THRU THD,AL	80009	129-0747-00
-94	129-0435-00		2		.SPACER,POST:0.625 L,W-6-32 THD THRU,BRS ***** (ATTACHING PARTS) *****	80009	129-0435-00
-95	211-0558-00		2		.SCREW,MACHINE:6-32 X 0.250 BDGH,NYL,SLOT ***** (END ATTACHING PARTS) *****	26365	921-1150-0014
-96	-----		1		.CONN,RCPT,ELEC:(SEE A4J101 REPL)		
-97	131-0346-01		1		.CONN,RCPT,ELEC:24 CONTACT,FEMALE ***** (ATTACHING PARTS) *****	71785	222-22-24-242
-98	210-3054-00		2		.EYELET,METALLIC:0.124 OD X 0.31 INCH LG,B	07707	S5570
-99	220-0937-00		2		.NUT BLOCK:0.5 L X 0.375 W X 0.25 H,AL ***** (END ATTACHING PARTS) *****	80009	220-0937-00
-100	-----		2		.CONNECTOR,RCPT:(SEE A4J154,J155 REPL) ***** (ATTACHING PARTS) *****		
-101	211-0159-00		4		.SCREW,MACHINE:2-56 X 0.375 INCH,PNH STL	87308	OBD
-102	210-0405-00		4		.NUT,PLAIN,HEX.:2-56 X 0.188 INCH,BRS ***** (END ATTACHING PARTS) *****	73743	12157-50
-103	-----		1		CKT BOARD ASSY:I/O(SEE A5 REPL)		
-104	-----		2		.CONN,RCPT,ELEC:(SEE A5P101A,P101B REPL)		
-105	136-0623-00		4		.SOCKET,PLUG-IN:40 DIP,LOW PROFILE	73803	CS9002-40
-106	129-0435-00		2		.SPACER,POST:0.625 L,W-6-32 THD THRU,BRS ***** (ATTACHING PARTS) *****	80009	129-0435-00
-107	211-0558-00		2		.SCREW,MACHINE:6-32 X 0.250 BDGH,NYL,SLOT ***** (END ATTACHING PARTS) *****	26365	921-1150-0014
-108	129-0747-00		6		.SPACER POST:0.633 L,W/6-32 THRU THD,AL	80009	129-0747-00
-109	-----		2		.CONNECTOR,RCPT:(SEE A5J2,J3 REPL) ***** (ATTACHING PARTS) *****		
-110	211-0159-00		4		.SCREW,MACHINE:2-56 X 0.375 INCH,PNH STL	87308	OBD
-111	210-0405-00		4		.NUT,PLAIN,HEX.:2-56 X 0.188 INCH,BRS ***** (END ATTACHING PARTS) *****	73743	12157-50
-112	361-0980-00		1		.SPACER,SLEEVE:0.640 L X 0.156 ID,BRASS CU	80009	361-0980-00
-113	-----		1		.CONN,RCPT,ELEC:(SEE A5J4 REPL)		
-114	211-0510-00		1		.SCREW,MACHINE:6-32 X 0.375,PNH,STL,CD PL	83385	OBD
-115	210-0006-00		1		.WASHER,LOCK:#6 INTL,0.018 THK,STL CD PL	78189	1206-00-00-0541C
-116	136-0651-00		1		.SKT,PL-IN ELEK:ANODE,7 CONTACT	80009	136-0651-00
-117	131-0621-00		8		.CONNECTOR,TERM:22-26 AWG,BRS & CU BE GOLD	22526	46231
-118	352-0204-00		1		.CONN BODY,PL,EL:8 WIRE BLACK	80009	352-0204-00
-119	175-0830-00		AR		.WIRE,ELECTRICAL:7 WIRE RIBBON	08261	SS-0726-710610C
-120	136-0271-00		1		.SOCKET,PLUG-IN:7 PIN	71785	111-01-10-012
-121	200-0811-00		1		.COVER,SKT TERM:0.81 OD X 0.849 L,PLASTIC	80009	200-0811-00
-122	358-0566-00		1		.INSULATOR,BSHG:0.625 ID X 0.406 THK,NYLON	28520	SB-812-10
-123	179-2355-00		1		.WIRING HARNESS:POWER	80009	179-2355-00
-124	131-0621-00		17		.CONNECTOR,TERM:22-26 AWG,BRS & CU BE GOLD	22526	46231
	131-0707-00		53		.CONNECTOR,TERM:22-26 AWG,BRS & CU BE GOLD	22526	47439
-125	175-0830-00		AR		.WIRE,ELECTRICAL:7 WIRE RIBBON	08261	SS-0726-710610C
-126	175-0831-00		AR		.WIRE,ELECTRICAL:8 WIRE RIBBON	08261	SS-0826-710610C
-127	352-0199-02		1		.CONN BODY,PL,EL:3 WIRE RED	80009	352-0199-02
-128	352-0200-02		1		.CONN BODY,PL,EL:4 WIRE RED	80009	352-0200-02
-129	352-0164-00		1		.CONN BODY,PL,EL:6 WIRE BLACK	80009	352-0164-00
-130	352-0165-00		1		.CONN BODY,PL,EL:7 WIRE BLACK	80009	352-0165-00
-131	352-0166-00		1		.CONN BODY,PL,EL:8 WIRE BLACK	80009	352-0166-00
-132	352-0206-01		1		.HLDR,TERM CONN:10 WIRE BROWN	80009	352-0206-01
-133	352-0429-00		1		.CONN BODY,PLUG:2/19 FEM CONT	22526	65043-071
-134	343-0549-00		9		.STRAP,TIEDOWN:0.091 W X 3.62 INCH LONG	06383	PLT1M
-135	175-2456-00		2		CA ASSY,SP,ELEC:34,28 AWG,2.0 L	22526	80564-001

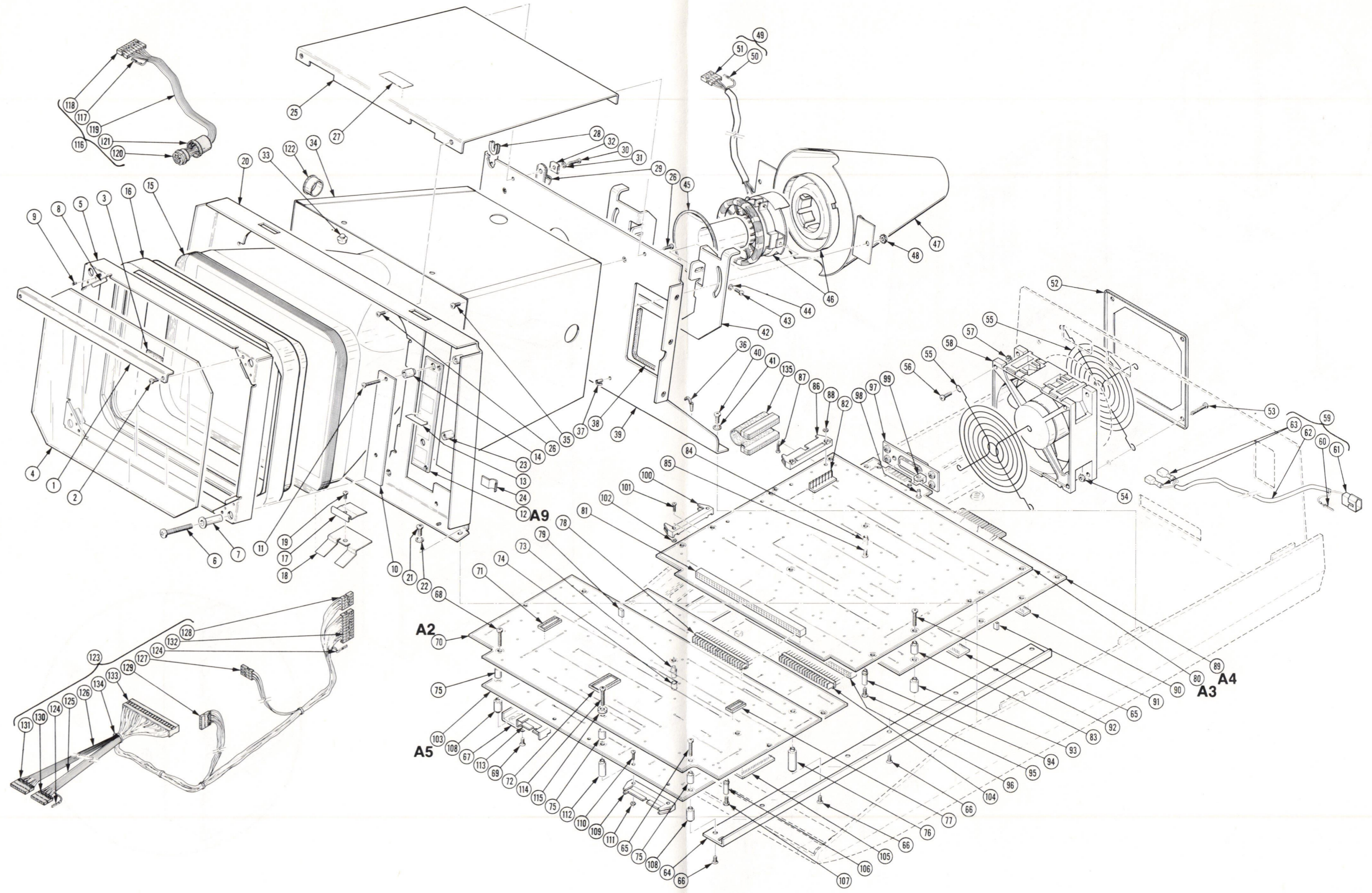

ADD JUL 1982

4052/4052A PARTS AND SCHEMATICS

FIG. 5 CRT FAN AND RAIL ASSEMBLY

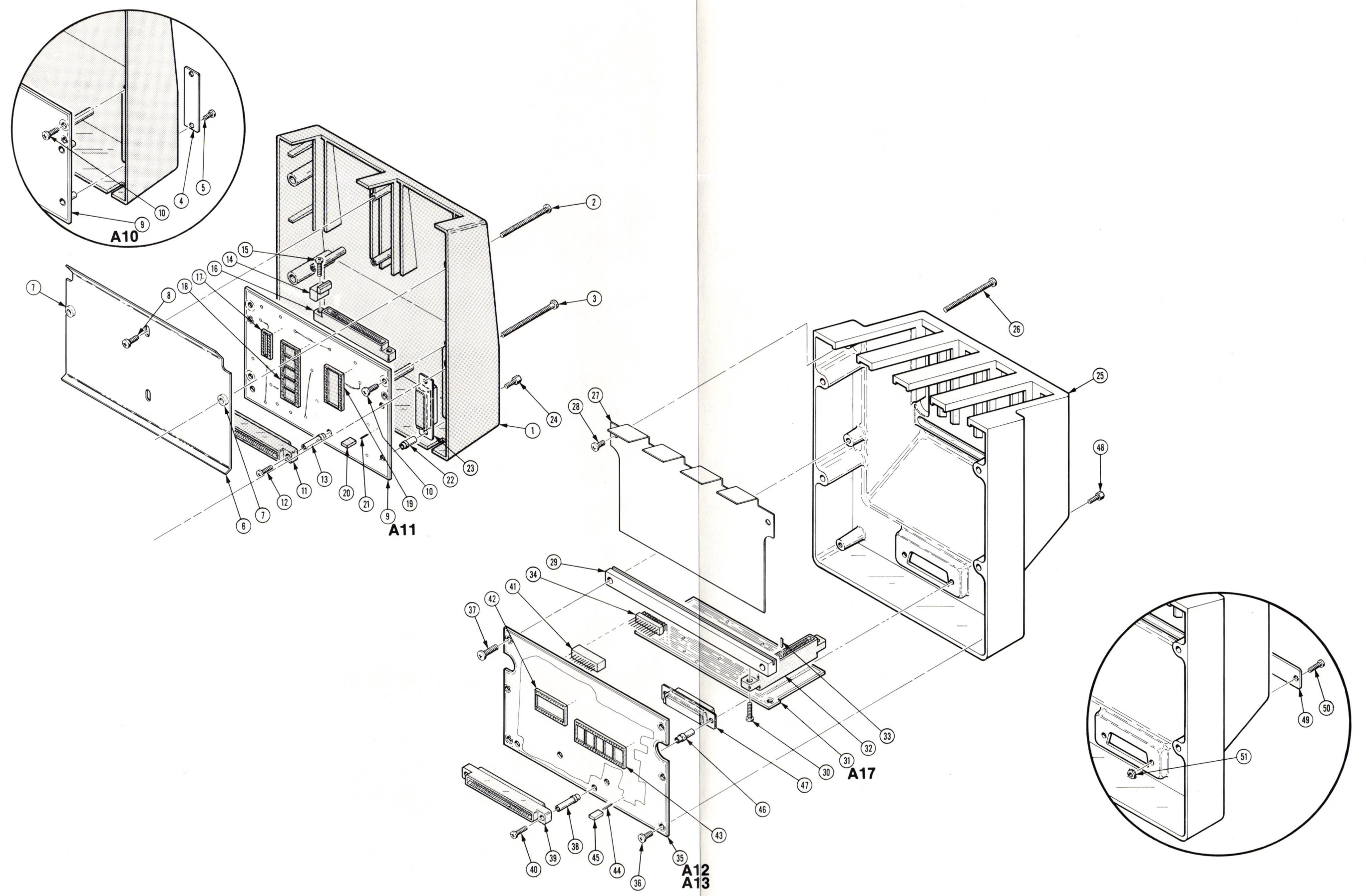

REPLACEABLE MECHANICAL PARTS

Fig. & Index No.	Tektronix Part No.	Serial/Model No.		Qty	1 2 3 4 5	Name & Description	Mfr Code	Mfr Part Number
		Eff	Dscont					
6-1	200-1851-03			1		COVER,ROM PACK:PLASTIC,SILVER GRAY (STANDARD ONLY)	80009	200-1851-03
	-----			-				
	200-1851-03			1		COVER,ROM PACK:PLASTIC,SILVER GRAY (OPTION 01 ONLY)	80009	200-1851-03
	-----			-		***** (ATTACHING PARTS) *****		
-2	211-0530-00			2		SCREW,MACHINE:6-32 X 1.75 INCH,PNH STL	83385	OBD
-3	211-0623-00			2		SCREW,MACHINE:6-32 X 2.25 INCHES,PNH,STL	83385	OBD
	-----			-		***** (END ATTACHING PARTS) *****		
-4	200-1887-00			1		.COVER,FIRMWARE:PLASTIC (STANDARD ONLY)	80009	200-1887-00
	-----			-		***** (ATTACHING PARTS) *****		
-5	211-0008-00			2		.SCREW,MACHINE:4-40 X 0.250,PNH,STL,CD PL (STANDARD ONLY)	83385	OBD
	-----			-		***** (END ATTACHING PARTS) *****		
-6	351-0452-01			1		.GUIDE,ROM PACK:ALUMINUM	80009	351-0452-01
	-----			-		***** (ATTACHING PARTS) *****		
-7	213-0054-00			2		.SCR,TPG,THD FOR:6-32 X 0.312 INCH,PNH STL	93907	OBD
	-----			-		***** (END ATTACHING PARTS) *****		
-8	361-1012-00			2		..SPACER,SLEEVE:0.295 L X 0.188 ID,BRASS	80009	361-1012-00
-9	-----			1		..CKT BOARD ASSY:FIRMWARE/COMM BACKPACK (SEE A10,A11 REPL)		
	-----			-		***** (ATTACHING PARTS) *****		
-10	213-0054-00			3		.SCR,TPG,THD FOR:6-32 X 0.312 INCH,PNH STL	93907	OBD
	-----			-		***** (END ATTACHING PARTS) *****		
-11	-----			1		..CKT BOARD ASSY INCLUDES: ..CONN,RCPT,ELEC:(SEE A10,A11P5 REPL)		
	-----			-		***** (ATTACHING PARTS) *****		
-12	211-0198-00			2		..SCREW,MACHINE:4-40 X 0.438 PNH,STL,POZ	77250	OBD
	-----			-		***** (END ATTACHING PARTS) *****		
-13	129-0248-00			2		..SPACER,POST:0.663 INCH LONG,BRS	80009	129-0248-00
-14	351-0500-00			4		..GUIDE,CKT CARD:	80009	351-0500-00
	-----			-		***** (ATTACHING PARTS) *****		
-15	211-0198-00			4		..SCREW,MACHINE:4-40 X 0.438 PNH,STL,POZ	77250	OBD
	-----			-		***** (END ATTACHING PARTS) *****		
-16	-----			2		..CONN,RCPT,ELEC:(SEE A10,A11J91,J92 REPL)		
-17	136-0260-02			1		..SKT,PL-IN ELEK:MICROCIRCUIT,16 DIP,LOW C	71785	133-51-92-008
	-----			-		..(OPTION 1 ONLY)		
-18	136-0623-00			1		..SOCKET,PLUG-IN:40 DIP,LOW PROFILE	73803	CS9002-40
	-----			-		..(OPTION 1 ONLY)		
-19	136-0578-00			1		..SKT,PL-IN ELEK:MICROCKT,24 PIN,LOW PROFI	73803	C S9002-24
	-----			-		..(OPTION 1 ONLY)		
-20	131-0993-00			3		..BUS,CONDUCTOR:2 WIRE BLACK	00779	850100-01
	-----			-		..(OPTION 1 ONLY)		
-21	131-0608-00			9		..TERMINAL,PIN:0.365 L X 0.025 PH BRZ GOLD	22526	47357
	-----			-		..(OPTION 1 ONLY)		
-22	129-0112-00			2		..SPACER,POST:0.406 L FROM MT SEAT X 0.21	80009	129-0112-00
	-----			-		..(OPTION 1 ONLY)		
-23	-----			1		..CONN,RCPT,ELEC:(SEE A11J93 REPL)		
	-----			-		..(OPTION 1 ONLY)		
-24	131-0890-00			2		LOCK,CONNECTOR:4-40 X 0.312 L	71468	D 20418-2
	334-2788-01			1		OVERLAY,KYBD:MARKED DATA COMMUNICATION (OPTION 1 ONLY)	80009	334-2788-01
	-----			-				
	175-1778-01			1		CA ASSY,SP,ELEC:34,28 AWG,2.5 L (OPTION 1 ONLY)	80009	175-1778-01
	-----			-				
-25	200-2414-01			1		COVER,ROM PACKS:4 POSITION,TEK TAN (OPTION 02 ONLY)	80009	200-2414-01
	-----			-				
	200-2414-01			1		COVER,ROM PACKS:4 POSITION,TEK TAN (OPTION 03 ONLY)	80009	200-2414-01
	-----			-		***** (ATTACHING PARTS) *****		
-26	211-0530-00			4		SCREW,MACHINE:6-32 X 1.75 INCH,PNH STL	83385	OBD
	-----			-		***** (END ATTACHING PARTS) *****		
-27	351-0609-00			1		GUIDE,ROM PACK:ALUMINUM	80009	351-0609-00
	-----			-		***** (ATTACHING PARTS) *****		
-28	211-0504-00			2		SCREW,MACHINE:6-32 X 0.25 INCH,PNH STL	83385	OBD
	-----			-		***** (END ATTACHING PARTS) *****		

REPLACEABLE MECHANICAL PARTS

Fig. & Index No.	Tektronix Part No.	Serial/Model No. Eff	Dscont	Qty	1	2	3	4	5	Name & Description	Mfr Code	Mfr Part Number
6-29	381-0420-00			1						BAR,SUPPORT:CONNECTOR ***** (ATTACHING PARTS) *****	80009	381-0420-00
-30	211-0198-00			4						SCREW,MACHINE:4-40 X 0.438 PNH,STL,POZ ***** (END ATTACHING PARTS) *****	77250	OBD
-31	-----			1						CKT BOARD ASSY:CONNECTOR(SEE A17 REPL)		
-32	131-1757-01			4						.CONN,RCPT,ELEC:CKT BD,24/44 CONT	05574	3VH22/1JND5
-33	214-3005-00			4						.KEY,CONN PLZN:NYLON	80009	214-3005-00
-34	131-2514-00			3						.CONN,RCPT,ELEC:CKT BD,2 X 10,MALE	00779	86479-1
-35	-----			1						CKT BOARD ASSY:SELECTOR,COMMUNICATION (SEE A12 & A13 REPL)		
	-----			-						***** (ATTACHING PARTS) *****		
-36	211-0504-00			2						SCREW,MACHINE:6-32 X 0.25 INCH,PNH STL	83385	OBD
-37	211-0551-00			2						SCREW,MACHINE:6-32 X 0.562 INCH,PNH STL ***** (END ATTACHING PARTS) *****	83385	OBD
	-----			-						CKT BOARD ASSY INCLUDES:		
-38	129-0248-00			2						.SPACER,POST:0.663 INCH LONG,BRS	80009	129-0248-00
-39	-----			1						.CONN,RCPT,ELEC:(SEE A12,A13P5 REPL) ***** (ATTACHING PARTS) *****		
-40	211-0198-00			2						.SCREW,MACHINE:4-40 X 0.438 PNH,STL,POZ ***** (END ATTACHING PARTS) *****	77250	OBD
-41	-----			3						.CONN,RCPT,ELEC:(SEE A12,A13P96,P97,P98 RE		
-42	136-0269-02			1						.SKT,PL-IN ELEK:MICROCIRCUIT,14 DIP,LOW CL (OPTION 3 ONLY)	73803	CS9002-14
-43	-----			1						.SOCKET,PLUG-IN:49 DIP,LOW PROFILE (OPTION 3 ONLY)		
-44	131-0608-00			9						.TERMINAL,PIN:0.365 L X 0.025 PH BRZ GOLD (OPTION 3 ONLY)	22526	47357
-45	131-0993-00			3						.BUS,CONDUCTOR:2 WIRE BLACK (OPTION 3 ONLY)	00779	850100-01
-46	129-0561-00			2						.SPACER,POST:0.535 L,W-4-40 INTL ONE END (OPTION 3 ONLY)	80009	129-0561-00
-47	-----			1						.CONN,RCPT,ELEC:(SEE A13J93 REPL) (OPTION 3 ONLY)		
-48	131-0890-00			2						LOCK,CONNECTOR:4-40 X 0.312 L (OPTION 3 ONLY)	71468	D 20418-2
-49	200-1887-00			1						COVER,FIRMWARE:PLASTIC (OPTION 2 ONLY)	80009	200-1887-00
	-----			-						***** (ATTACHING PARTS) *****		
-50	211-0097-00			2						SCREW,MACHINE:4-40 X 0.312 INCH,PNH STL (OPTION 2 ONLY)	83385	OBD
-51	210-0586-00			2						NUT,PL,ASSEM WA:4-40 X 0.25,STL (OPTION 2 ONLY)	83385	OBD
	-----			-						***** (END ATTACHING PARTS) *****		
										OPTION 2 STANDARD ACCESSORIES		
	070-2066-01			1						MANUAL,TECH:OPERATORS	80009	070-2066-01
										OPTION 1,3 STANDARD ACCESSORIES		
	012-0689-02			1						CABLE,INTCON:192.0 L	04919	762-125
	013-0173-01			1						ADAPTER ASSY:SELF TEST	80009	013-0173-01
	070-2066-01			1						MANUAL,TECH:OPERATORS	80009	070-2066-01

REPLACEABLE MECHANICAL PARTS

Fig. & Index No.	Tektronix Part No.	Serial/Model No.		Qty	1 2 3 4 5					Name & Description	Mfr Code	Mfr Part Number
		Eff	Dscont									
7-1	380-0384-01			1						HSG HALF,ROM PK:LID,ABS *****ATTACHING PARTS*****	80009	380-0384-01
-2	211-0102-00			4						SCREW,MACHINE:4-40 X 0.500",FLH,STL *****END ATTACHING PARTS*****	83385	OBD
-3	367-0189-00			1						HANDLE,BOW:2.62 L,SST	91260	OBD
-4	380-0343-01			1						HSG HALF,PTR:INNER,ABS	80009	380-0343-01
	-----			1						MKR,SET,IDENT:MKD EDITOR ROM PACK (4052R06 ONLY)		
-5	-----			1						CKT BOARD ASSY:16K ROM PACK(SEE A15,A16 RE		
-6	136-0578-00			1						.SKT,PL-IN ELEK:MICROCKT,24 PIN,LOW PROFIL	73803	C S9002-24
-7	-----			1						MKR SET,IDENT:MKD 4052 SIG PROC #1 (4052R07 ONLY)		
-8	334-2954-01			5						OVERLAY,KYBD:MARKED EDITOR ROM PACK (4052R06 ONLY)	80009	334-2954-01
	-----			-								

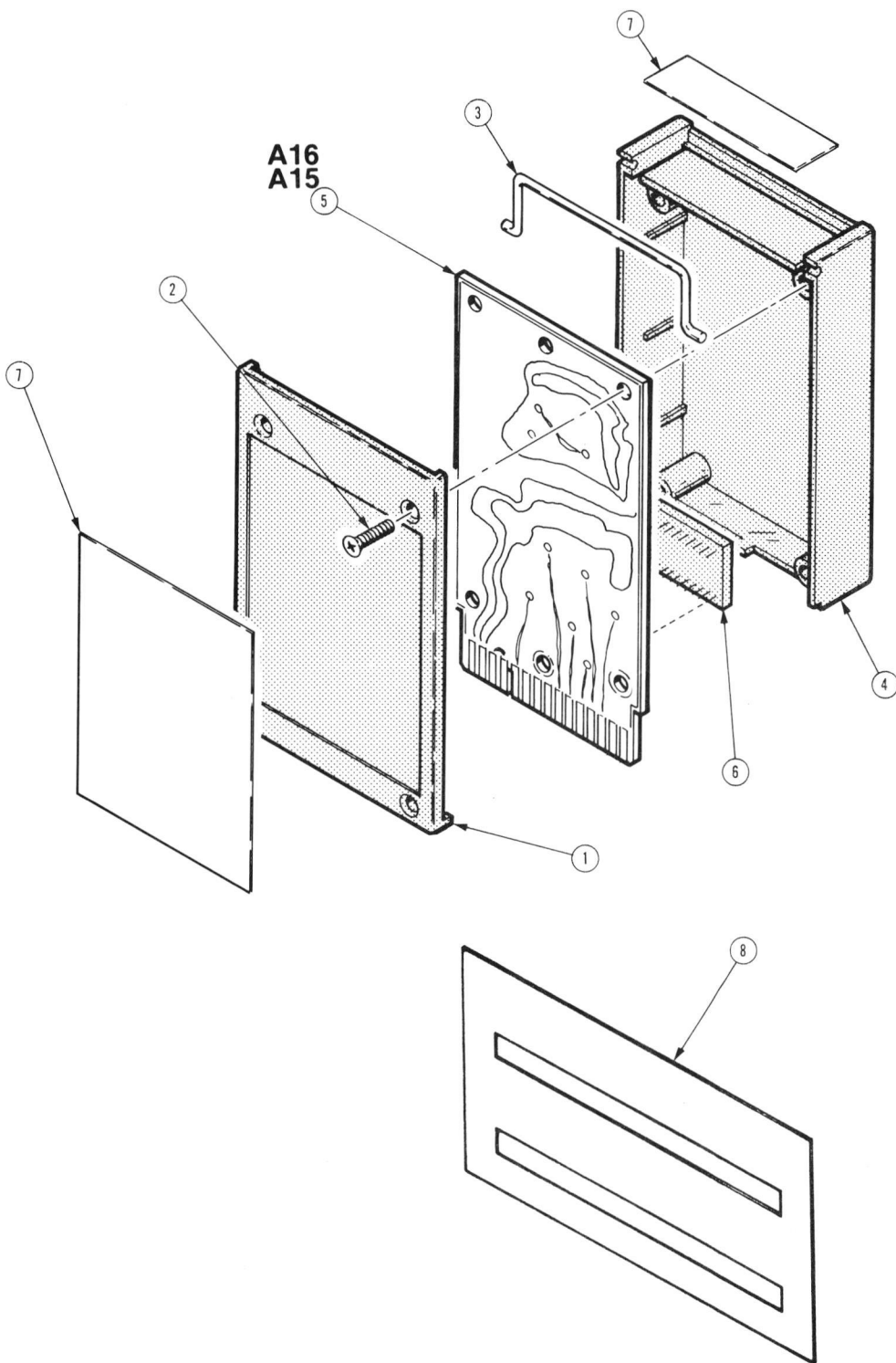

ADD JUL 1982

4052/4052A PARTS AND SCHEMATICS

FIG. 7 ROM PACKS

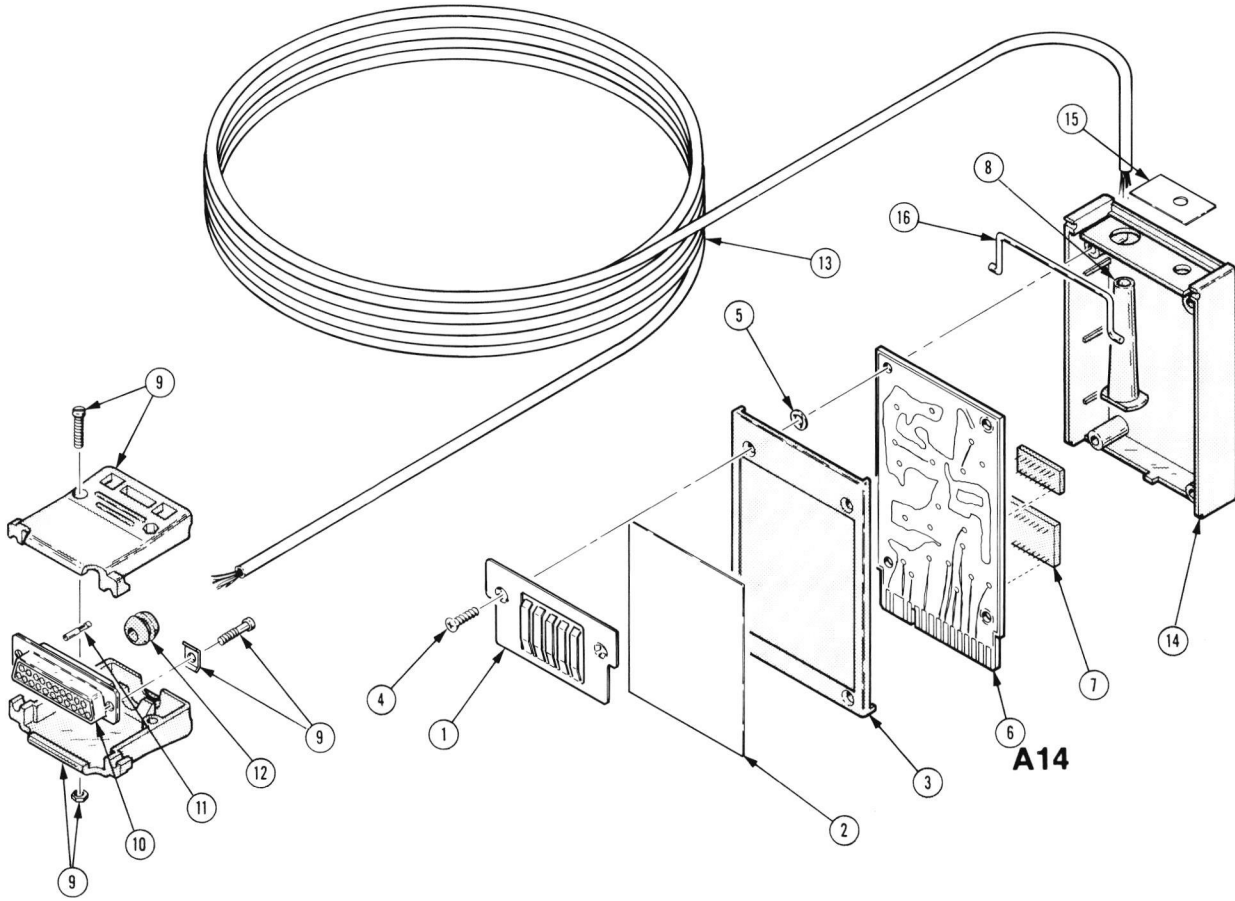

FIG. 8 RS-232 PRINTER INTERFACE

REPLACEABLE MECHANICAL PARTS

Fig. & Index No.	Tektronix Part No.	Serial/Model No.		Qty	1 2 3 4 5	Name & Description	Mfr Code	Mfr Part Number
		Eff	Dscont					
8-1	131-2442-00			1		CONTACT,ELEC:GROUNDING,PH BRZ	80009	131-2442-00
-2	334-3693-00			1		MARKER,IDENT:MKD RS232 PRINTER	80009	334-3693-00
-3	380-0384-01			1		HSG HALF,ROM PK:LID,ABS ***** (ATTACHING PARTS) *****	80009	380-0384-01
-4	211-0102-00			4		SCREW,MACHINE:4-40 X 0.500",FLH,STL ***** (END ATTACHING PARTS) *****	83385	OBD
-5	210-1333-00			2		WASHER,FLAT:0.09 ID X 0.007 THK,CU BE	80009	210-1333-00
-6	-----			1		CKT BOARD ASSY:RS232(SEE A14 REPL)		
-7	136-0751-00			1		.SKT,PL-IN ELEK:MICROCKT,24 PIN	09922	DILB24P108
-8	200-1042-03			1		.CABLE NIP,ELEC:0.194 ID,2.0 L,PLASTIC	80009	200-1042-03
	175-2430-00			1		.CA ASSY,SP,ELEC:7,26 AWG,3 METERS	80009	175-2430-00
-9	200-1667-00			1		..SHLD ELEC CONN:25 CONTACT,TYPE HD SIZE 3	80009	200-1667-00
-10	131-1461-00			1		..CONN BODY,RCPT:25 FEMALE CONTACTS	00779	205207-1
-11	131-1279-01			8		..CONTACT,ELEC:FEMALE	00779	66505-4
-12	348-0020-00			1		..GROMMET,RUBBER:0.25 INCH	70485	374
-13	175-1747-00			AR		..CABLE,SP,ELEC:7,26 AWG,0.165 DIA	80009	175-1747-00
-14	380-0343-03			1		.HSG HALF,PTR:INNER,ABS	80009	380-0343-03
-15	334-3638-00			1		.MARKER,IDENT:MARKED BAUD RATE	80009	334-3638-00
-16	367-0189-00			1		HANDLE,BOW:2.62 L,SST	91260	OBD
						OPTION 10 STANDARD ACCESSORIES		
	070-2908-00			1		MANUAL,TECH:INSTRUCTION	80009	070-2908-00

REPLACEABLE MECHANICAL PARTS

Fig. & Index No.	Tektronix Part No.	Serial/Model No. Eff Dscont	Qty	1	2	3	4	5	Name & Description	Mfr Code	Mfr Part Number
STANDARD ACCESSORIES											
9-1	161-0066-00		1						CABLE ASSY,PWR,:3,18 AWG,115V,98.0 L	S3109	1100
-2	161-0066-09		1						CABLE ASSY,PWR:3,0.75MM SQ,220V,96.0 L	80009	161-0066-09
	-----		-						(OPTION A1 ONLY)		
-3	161-0066-10		1						CABLE ASSY,PWR:3,0.75MM SQ,240V,96.0 L	80009	161-0066-10
	-----		-						(OPTION A2 ONLY)		
-4	161-0066-11		1						CABLE ASSY,PWR:3,0.75MM,240V,96.0L	80009	161-0066-11
	-----		-						(OPTION A3 ONLY)		
-5	161-0066-12		1						CABLE ASSY,PWR:3,18 AWG,240V,96.0 L	70903	OBD
	-----		-						(OPTION A4 ONLY)		
-6	161-0154-00		1						CABLE ASSY,PWR:3,0.75MM SQ,240V,6A,2.5M L	000JA	A25SW
	-----		-						(OPTION A5 ONLY)		
	020-0160-03		1						TAPE CARTRIDGE:PLOT 50 SYSTEM SOFTWARE	80009	020-0160-03
	020-0161-03		1						TAPE CARTRIDGE:PLOT 50 SYSTEM SOFTWARE	80009	020-0161-03
	016-0353-00		1						BDR,LOOSE-LEAF:2.0 CAP RING,VINYL COVER	80009	016-0353-00
	016-0367-00		1						BDR,LOOSE-LEAF:2.0 CAP RING,VINYL COVER	80009	016-0367-00
	016-0369-00		1						DIV,LOOSE LEAF:6 OVERLAY POCKETS,VINYL	80009	016-0369-00
	334-3571-00		1						MARKER,IDENT:MARKED OPERATORS MANUAL	80009	334-3571-00
	334-3572-00		1						MARKER,IDENT:MARKED REFERENCE	80009	334-3572-00
	-----		1						OVERLAY,KYBD:BLANK		
	070-1940-01		1						MANUAL,TECH:OPERATOR 4050 SERIES	80009	070-1940-01
	070-2056-01		1						MANUAL,TECH:REFERENCE	80009	070-2056-01
	070-2142-01		1						CARD,INFO:REFERENCE	80009	070-2142-01
	070-2058-01		1						MANUAL,TECH:INSTRUCTION	80009	070-2058-01
	070-2059-01		1						MANUAL,TECH:INSTRUCTION	80009	070-2059-01
	070-4459-00		1						SHEET,TECHNICAL DATA:	80009	070-4459-00
OPTIONAL ACCESSORIES											
	012-0630-01		1						CABLE,INTCON:2 METERS LONG	74868	AC30111102 REVC
	119-0680-01		1						CARTRIDGE,TAPE:MAGNETIC	80009	119-0680-01
	119-1439-00		1						CARTRIDGE,TAPE:450 FT X 0.25 IN	12578	DC300XL
	119-1463-00		1						CARTRIDGE,TAPE:600 FT X 0.25 IN		
	334-2630-02		1						OVERLAY,KYBD:BLANK,PACKAGE OF TEN	80009	334-2630-02
	070-2829-01		1						MANUAL,TECH:SERVICE	80009	070-2829-01
	016-0364-00		1						PEDESTAL KIT:	80009	016-0364-00

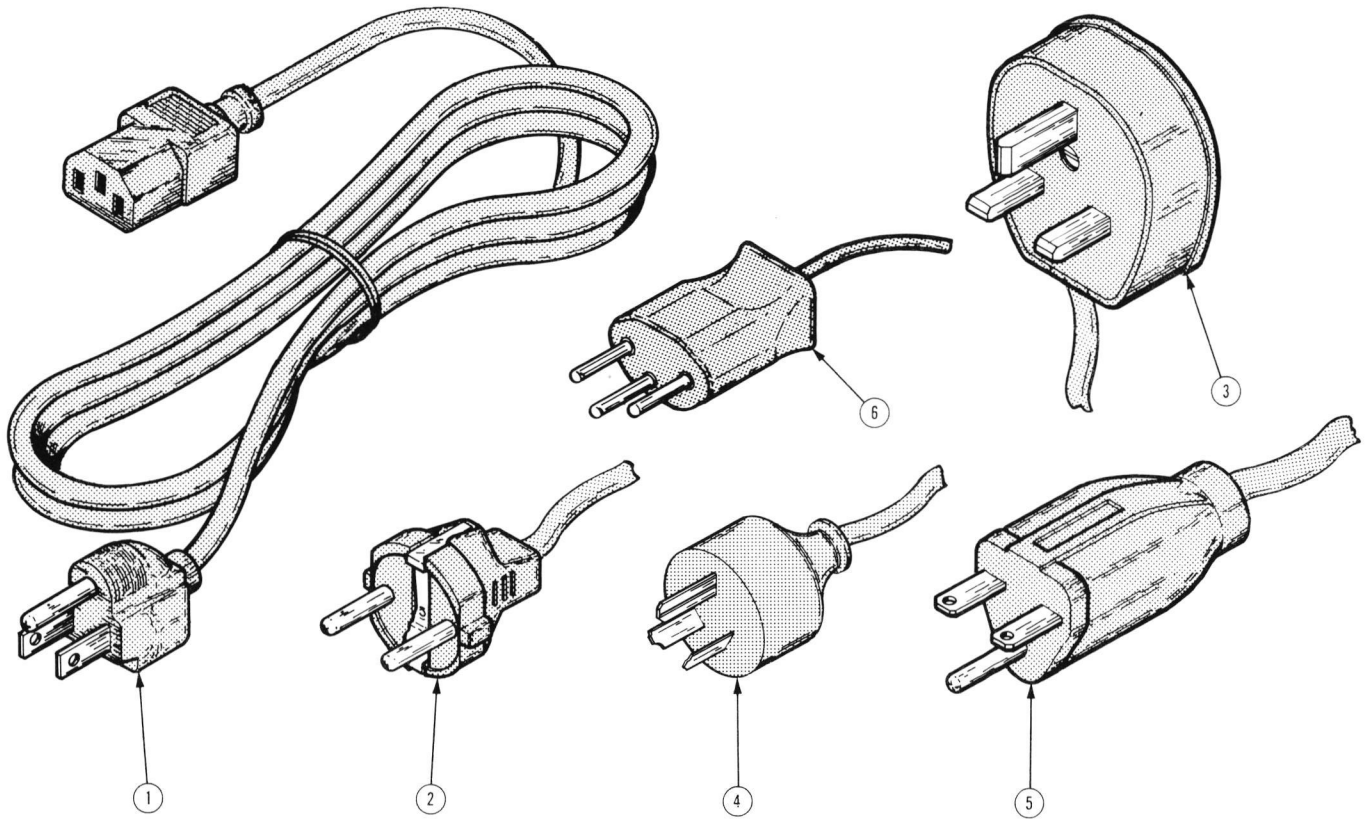

OPTIONS

OPT	ORDER NO.	DESCRIPTION
01	4052F01	FLD INSTL INTFC:DATA COMMUNICATION
02	4052F02	FIELD INSTALLED:4 SLOT ROM BACKPACK
03	4052F03	FLD INSTL INTFC:DATA COMM 4 SLOT
10	4052F10	FLD INSTL INTFC:RS232 PRINTER
24		MOD KIT:MEMORY EXPANSION
27	4052F27	EXTENDED MEMORY:256K
28	4052F28	EXTENDED MEMORY:512K
A1		UNIVERSAL EUROPEAN:POWER OPTION
A2		240V UK POWER:OPTION
A3		240V AUSTRALIAN:POWER OPTION
A4		240V NORTH AMERICAN:POWER OPTION
A5		220V SWISS:POWER OPTION

OPTIONS

MANUAL CHANGE INFORMATION

PRODUCT 4052/4052A GRAPHIC COMPUTING SYSTEM SERVICE

CHANGE REFERENCE M48424 REV

MANUAL PART NO. 070-2829-01

DATE 2-22-83

Revised 8-8-83

EFFECTIVE SERIAL NUMBER: B012064 (R06)
B011307 (R07)

SCHEMATIC CHANGES

Schematics

ADD THESE SCHEMATICS TO YOUR MANUAL:

A15-1 EDITOR ROM PACK

A16-1 SIGNAL PROCESSING ROM PACK NO. 1

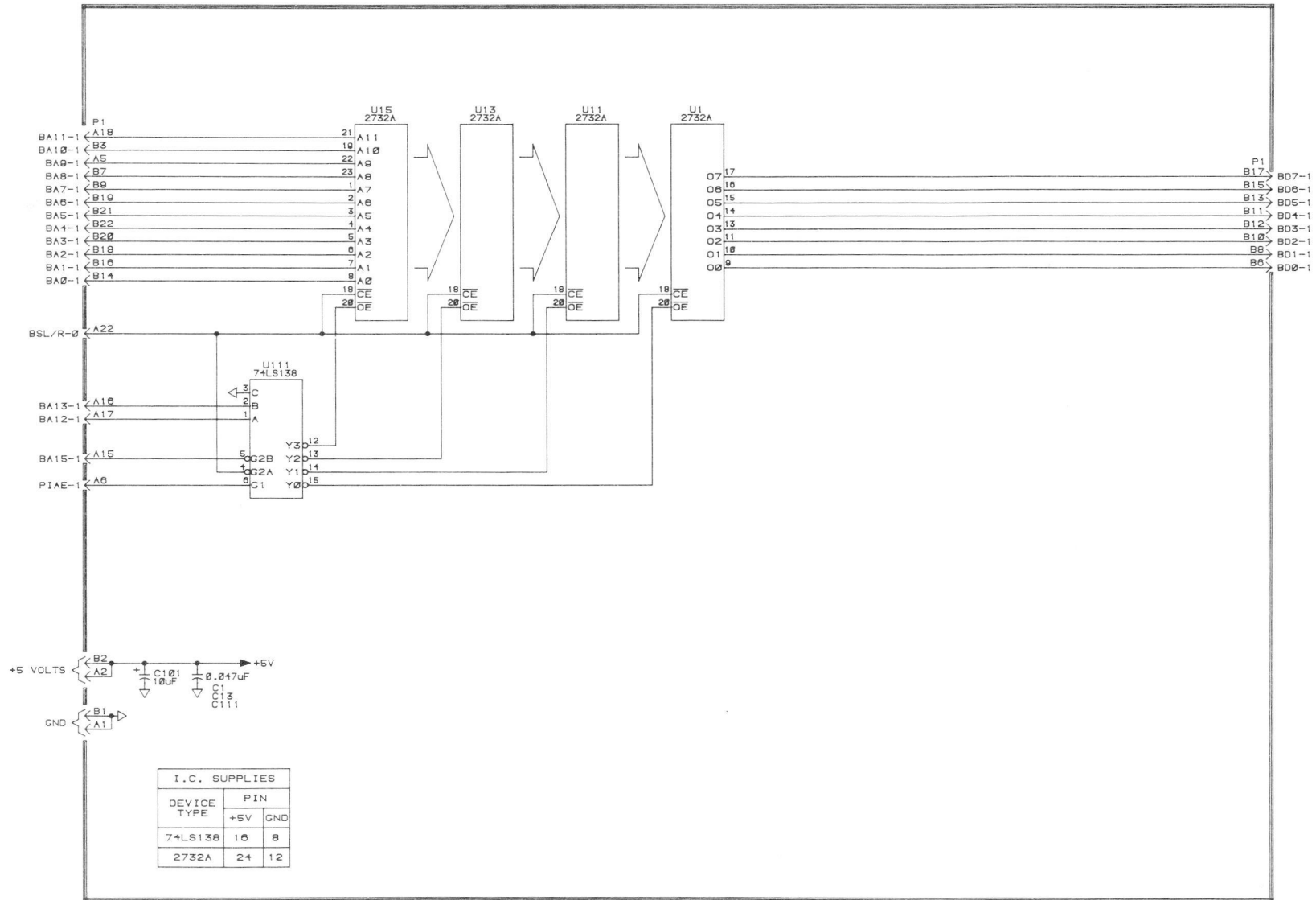

INSTRUMENT:
4052/4052A
R06

NOTES: KEYSLOT LOCATED BETWEEN PINS A6 & A7.

ADD, MAR 1983
2829-S57

BOARD: 670-7485-01 16K ROM PACK
EDITOR ROM PACK

ASSEMBLY-SHEET:
A15-1
(1 OF 1)

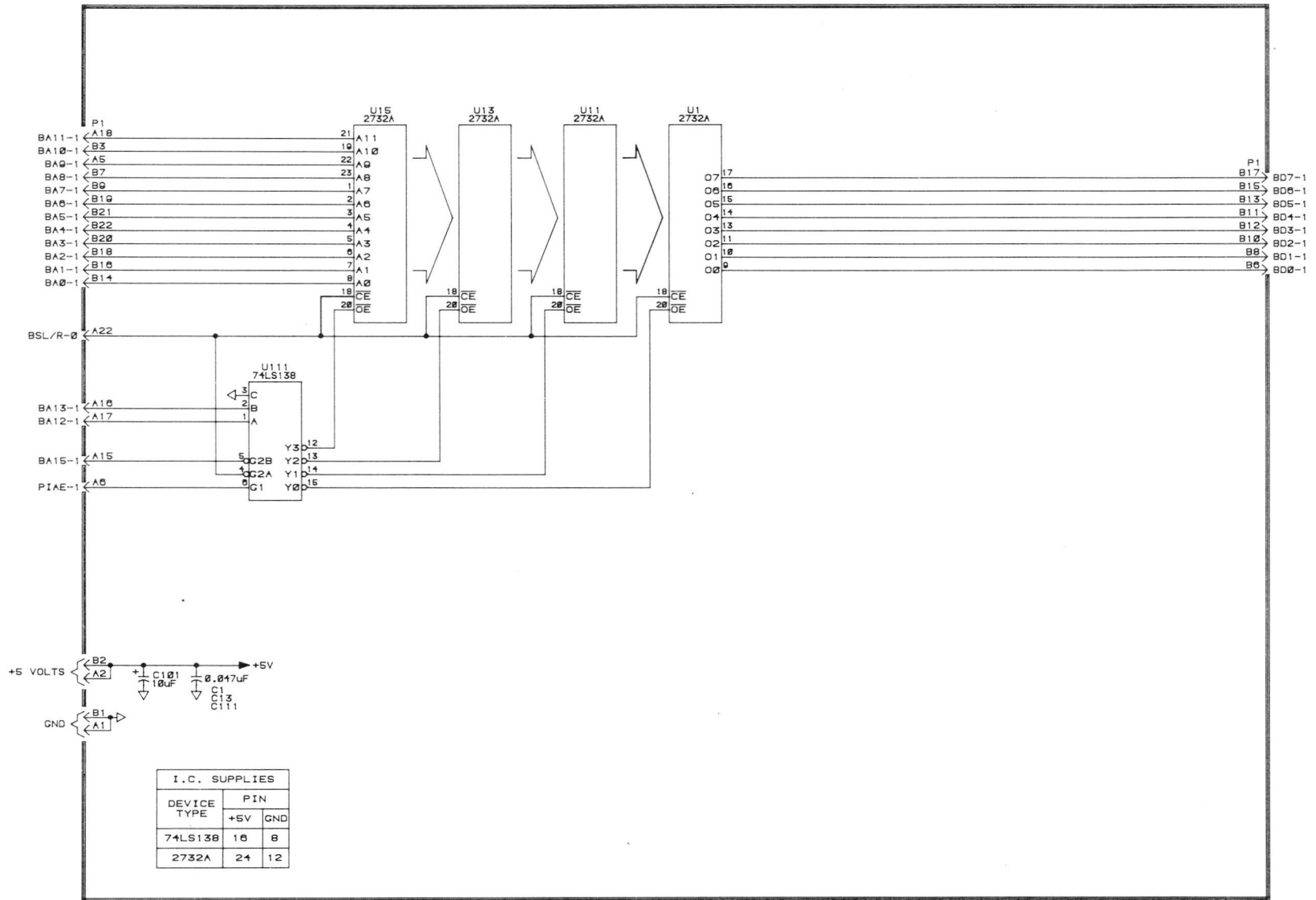

INSTRUMENT:
4052/4052A
R07

NOTES: KEYSLOT LOCATED BETWEEN PINS A6 & A7.

ADD, MAR 1983
2820-858

BOARD: 870-7488-01 16K ROM PACK
SIGNAL PROCESSING
ROM PACK NO.1

ASSEMBLY-SHEET:
A16-1
(1 OF 1)

PRODUCT 4052 & 4052A GRAPHIC COMPUTING SYSTEM SERVICE

CHANGE REFERENCE M48904 REV

MANUAL PART NO. 070-2829-01

DATE 4-7-83

EFFECTIVE SERIAL NUMBER: B044963

Revised 8-8-83

SCHEMATIC CHANGES

Schematic A1-1 LINE SELECTOR & REGULATOR

CHANGE AS INDICATED BELOW

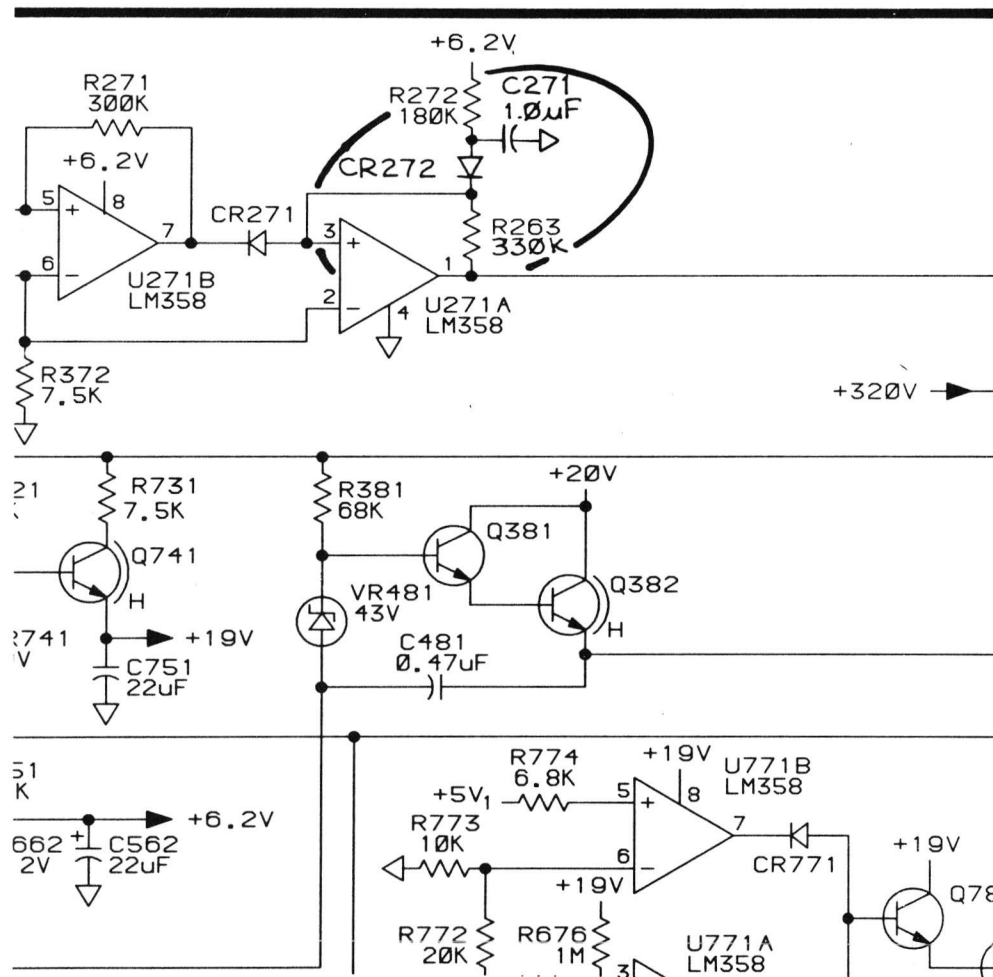

MANUAL CHANGE INFORMATION

PRODUCT 4052/4052A GRAPHIC COMPUTING SYSTEM SERVICE MANUAL CHANGE REFERENCE C7/1182 REV
MANUAL PART NO. 070-2829-01 DATE 11-24-82

EFFECTIVE SERIAL NUMBER: B050000

SCHEMATICS AND COMPONENT LOCATIONS CHANGES

Add the attached Schematics and Component Locations to your manual. This information describes the revised ALU board for the 4052A. The new board replaces the earlier version used on the 4052A. Parts information is the the parts section of this manual.

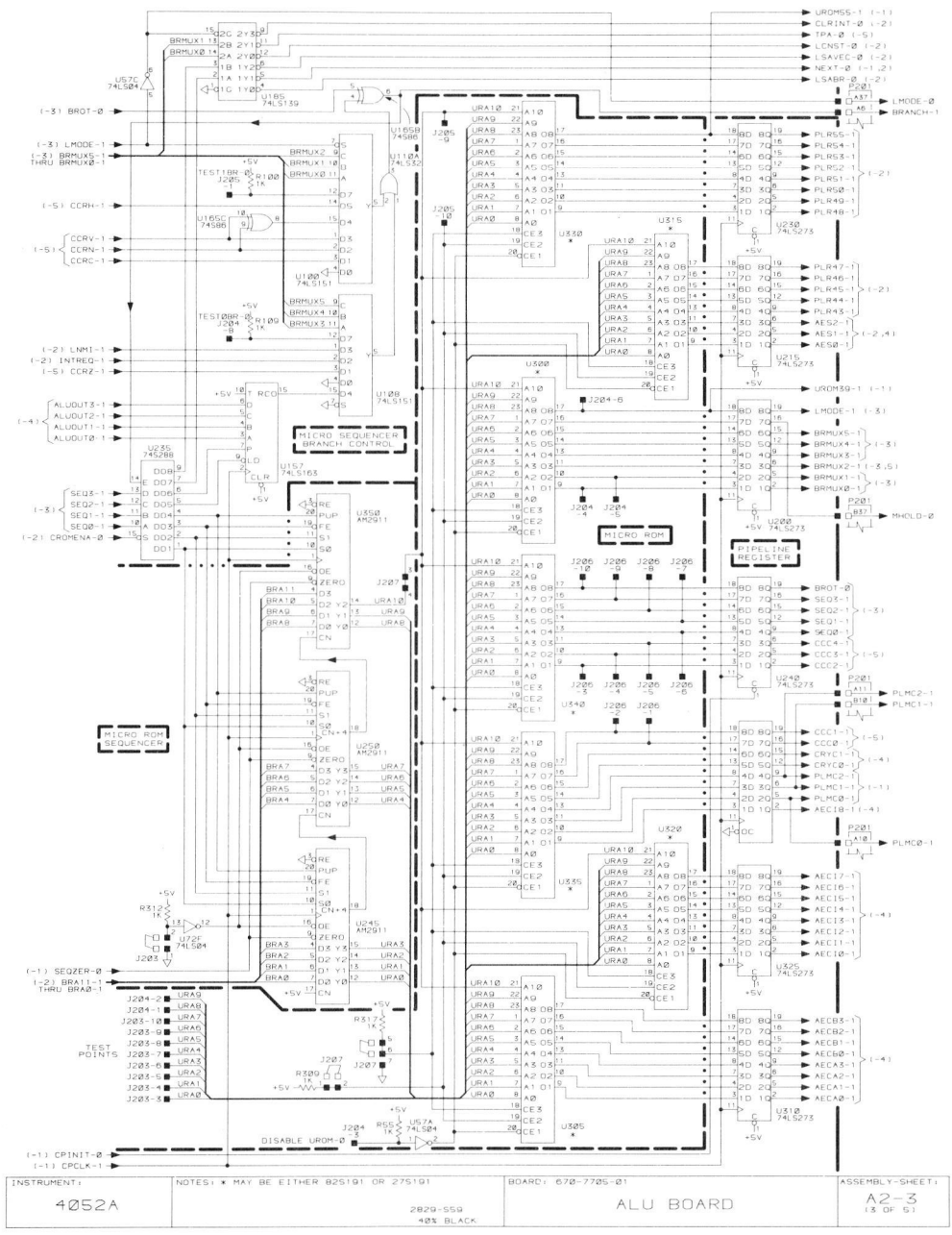

INSTRUMENT: 4052A NOTES: * MAY BE EITHER 825101 OR 275101 BOARD: 670-7705-01 ASSEMBLY-SHEET: A2-3 (3 OF 6)

2829-550 ALU BOARD

48% BLACK

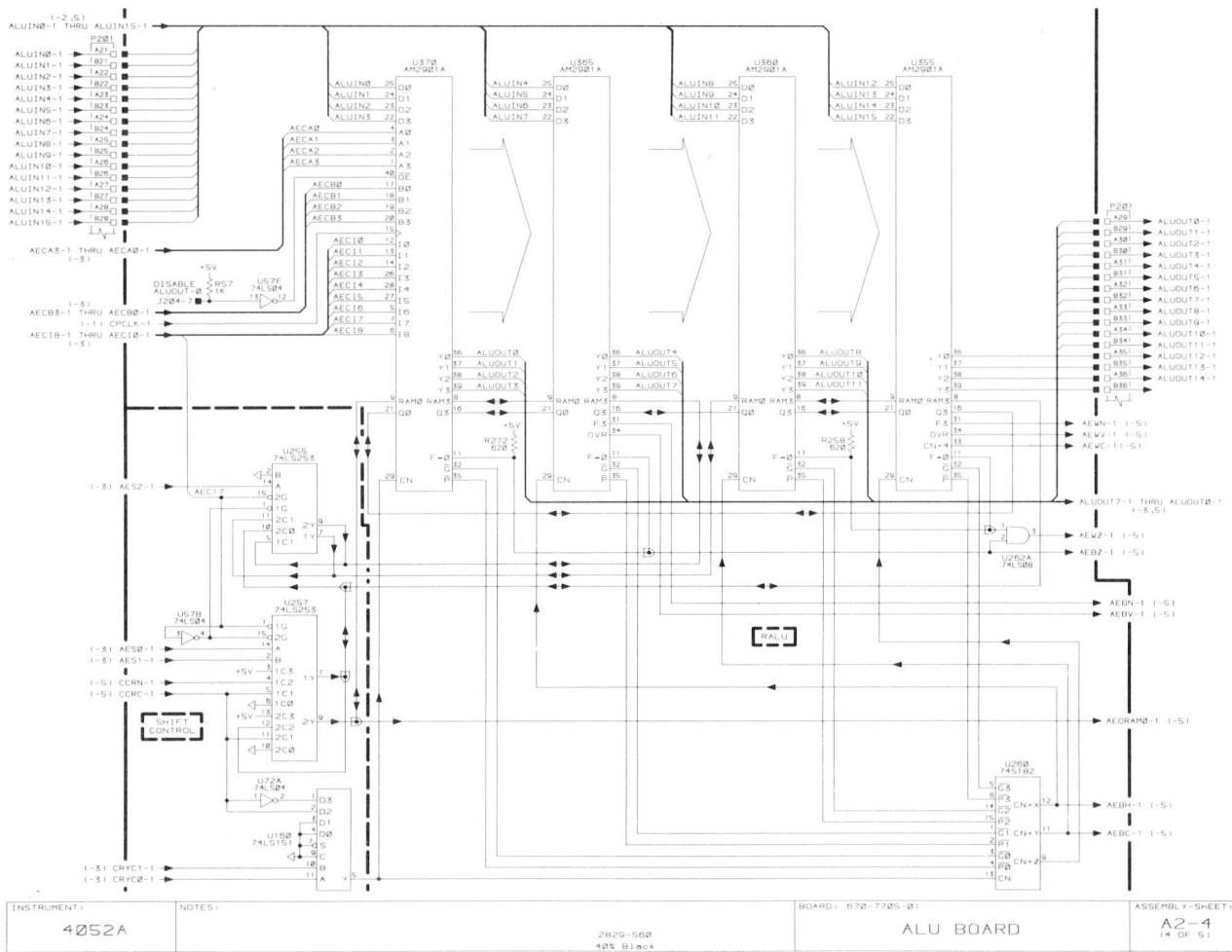

INSTRUMENT: 4052A

NOTES: 2B20-560 40% Black

BOARD: 670-7705-01 ALU BOARD

ASSEMBLY SHEET: A2-4 (4 OF 5)

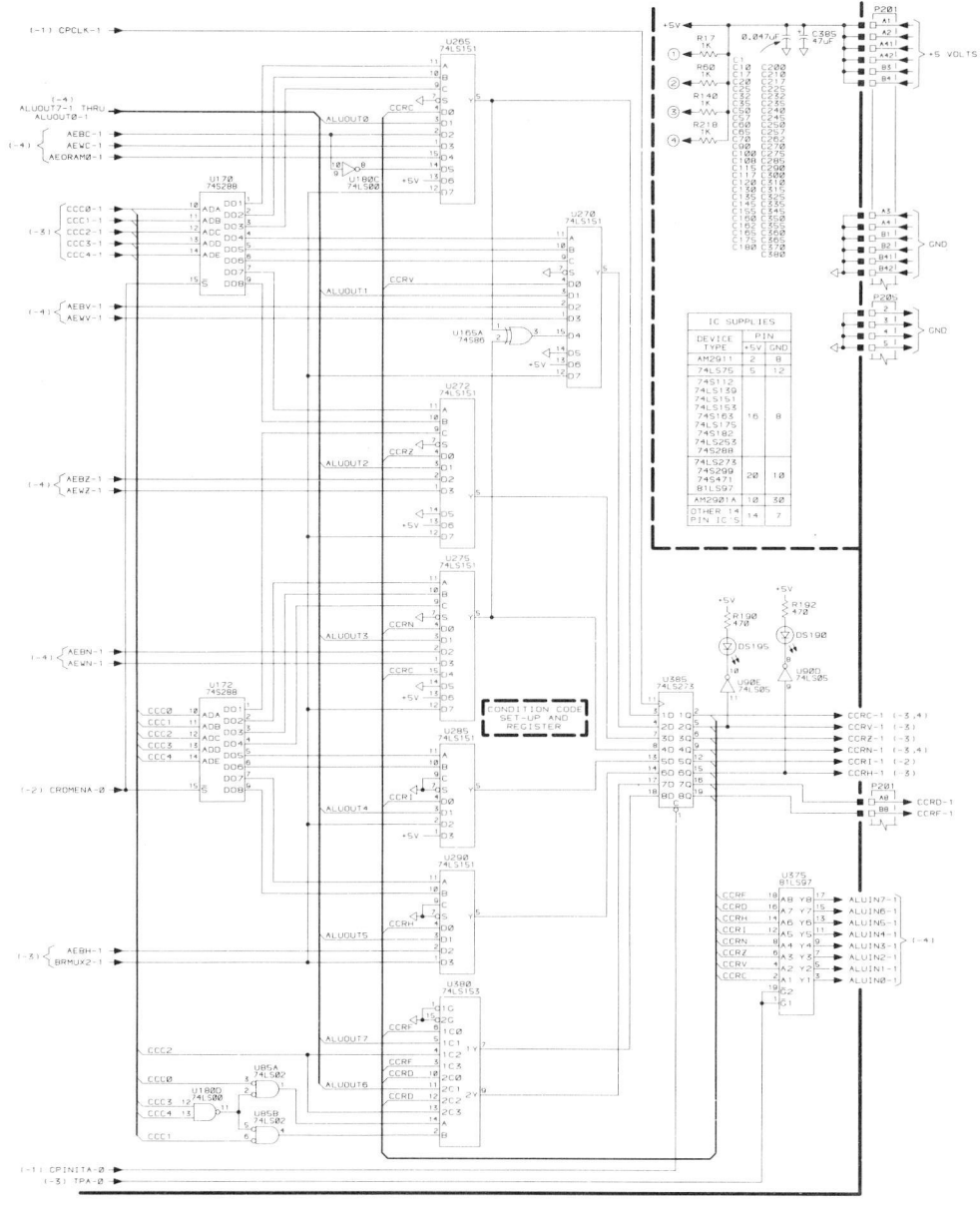

INSTRUMENT: 4052A	NOTES: 2820-561 40% Black	BOARD: 670-7705-01 ALU BOARD	ASSEMBLY SHEET: A2-5 15 OF 51
----------------------	---------------------------------	---------------------------------	-------------------------------------

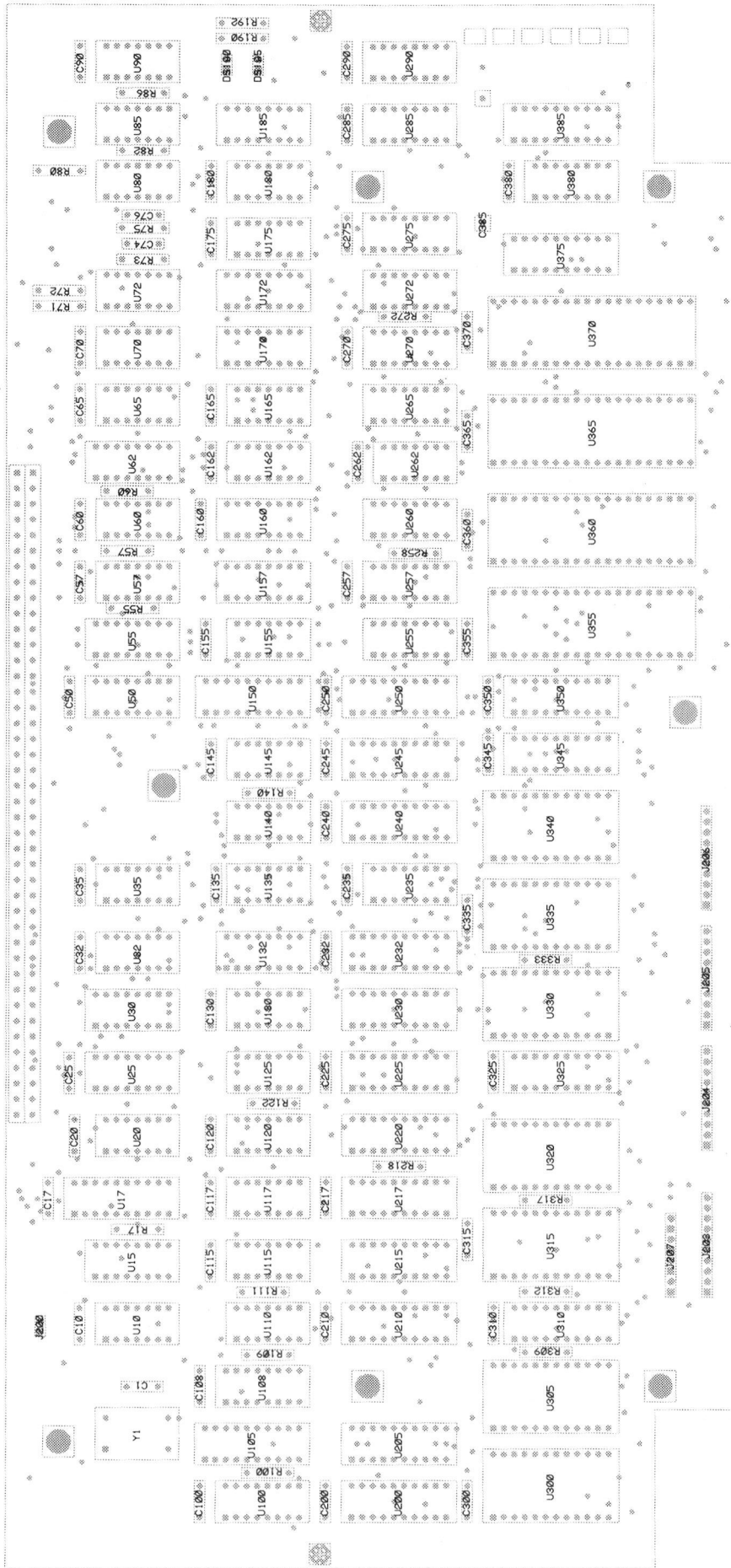

ALU Board Component Locations (670-7705-01).