

581
KEITHLEY INSTRUMENTS

Model 182 Sensitive Digital Voltmeter Instruction Manual



Contains Operating and Servicing Information

Publication Date: October 1990
Document Number: 182-901-01 Rev. A

DI  TORY

**Instruction Manual
Model 182
Sensitive Digital Voltmeter**

©1990, Keithley Instruments, Inc.
All Rights Reserved
Instruments Division
Cleveland, Ohio, U. S. A.
Document Number: 182-901-01

All Keithley product names are trademarks or registered trademarks of Keithley Instruments, Inc.

Other brand and product names are trademarks or registered trademarks of their respective holders.

SAFETY PRECAUTIONS

Although the Model 182 Sensitive Digital Voltmeter would normally be used with non-hazardous voltages, there are situations where hazardous conditions may be present. For that reason, the following safety precautions should be observed before using the Model 182.

The Model 182 Sensitive Digital Voltmeter is intended for use by qualified personnel who recognize shock hazards and are familiar with the safety precautions required to avoid possible injury. Read over this manual carefully before using the instrument.

Exercise extreme caution when a shock hazard is present. The American National Standards Institute (ANSI) states that shock hazard exists when voltage levels greater than 30V RMS or 42.4V peak are present. **A good safety practice is to expect that hazardous voltage is present in any unknown circuit before measuring.**

Inspect the connecting cables, test leads, and jumpers for possible wear, cracks, or breaks before each use.

For maximum safety, do not touch the test circuit, test cables or any instruments while power is applied to the circuit under test. Turn off all power and discharge any capacitors before connecting or disconnecting cables.

Do not touch any object which could provide a current path to the common side of the circuit under test or power line (earth) ground. Always make measurements with dry hands while standing on a dry, insulated surface capable of withstanding the voltage being measured.

Do not exceed the maximum signal levels of the instrument, as shown on the rear panel and as defined in the specifications and operation section of the instruction manual.

Instrumentation and accessories should not be connected to humans.

Model 182

Sensitive Digital Voltmeter

VOLTMETER

ACCURACY and STABILITY¹, \pm (ppm of reading + ppm of range):

RANGE	RESOLUTION	ACCURACY			TRANSFER STABILITY
		24 Hours 22°-24°C	90 Days 18°-28°C	1 Year 18°-28°C	5 Minutes $\pm 1^\circ\text{C}$
3 mV	1 nV	20 + 16*	40 + 16*	60 + 16*	5 + 9*
30 mV	10 nV	20 + 6*	40 + 6*	60 + 6*	3 + 2*
300 mV	100 nV	15 + 6	35 + 6	55 + 6	3 + 2
3 V	1 μV	10 + 4	30 + 6	50 + 6	3 + 2
30 V	10 μV	10 + 4	30 + 6	50 + 6	3 + 2

*When properly zeroed using REL function.

¹Integration set to 1 Power Line Cycle (PLC), Analog Filter off, Digital Filter set to medium, 1 hour warm-up. Accuracy specifications exclude calibrator accuracy. Add 4 ppm of reading to accuracy specifications for factory calibration.

ACCURACY TEMPERATURE COEFFICIENT:

\pm (4 ppm of input + 1 ppm of range)/°C, 0°-18°C and 28°-35°C.

MAXIMUM INPUT: 120V for 10 seconds, 35V continuous.

NOISE vs. SOURCE RESISTANCE¹:

SOURCE RESISTANCE	NOISE	ANALOG FILTER	DIGITAL FILTER
0 - 100 Ω	15 nV p-p	off	medium
1 k Ω	20 nV p-p	off	medium
10 k Ω	50 nV p-p	off	medium
100 k Ω	160 nV p-p	on	slow
1 M Ω	500 nV p-p	on	slow

¹3mV range, Integration set to 1 PLC, 2 minute observation, $\pm 1^\circ\text{C}$.

INPUT IMPEDANCE: >10G Ω (at 6 1/2 digits), >1G Ω (at 4 1/2 digits), 5nF nominal.

INPUT BIAS CURRENT: <50pA.

COMMON MODE CURRENT: <50nA p-p at 50Hz or 60Hz.

EFFECTIVE COMMON MODE REJECTION RATIO¹:

RANGE	ECMRR
3 mV - 3 V	160 dB
30 V	140 dB

¹At DC, 50Hz or 60Hz ($\pm 0.05\%$) with 1k Ω in either input lead.

NORMAL MODE REJECTION RATIO¹:

RANGE	NMRR
3 mV	90 dB
30 mV - 3 V	80 dB
30 V	60 dB

¹At 50Hz or 60Hz ($\pm 0.05\%$), Analog Filter on, Digital Filter set to medium, Integration set to 1 PLC.

ANALOG FILTER: Programmable for off or on. Nominal 8Hz bandwidth.

DIGITAL FILTER: Programmable for off, fast, medium or slow response.

INTEGRATION TIMES: 3ms, 1 PLC, or 100ms.

EXAMPLE READING RATES

RANGE	INTEGRATION	RESOLUTION	READINGS PER SECOND
30 V	3 ms	1 mV	100 ¹
3 mV	1 PLC	1 nV	15 ²
3 mV	1 PLC	1 nV	17 ³
3 mV	1 PLC	1 nV	4 ⁴

¹Into Data Buffer, Analog Filter off, Digital Filter off, Analog Output in source mode.

²Into Data Buffer, Multiple Trigger, Analog Filter off, Digital Filter on.

³IEEE-488 bus, Trigger on Talk, C0 format, Analog Filter off, Digital Filter off.

⁴IEEE-488 bus, Trigger on Talk, C0 format, Analog Filter on, Digital Filter off.

READING REL: Selects value of input which represents 0V reading. The reference value can be either a programmed value or the value of the previous input.

MAXIMUM READING: 3029999 counts.

ANALOG OUTPUT

MAXIMUM OUTPUT: $\pm 3\text{V}$.

ACCURACY: $\pm 0.15\%$ of output + 1mV).

OUTPUT RESISTANCE: 1k Ω nominal.

GAIN: Adjustable from 10^{-3} to 10^6 . With gain set to 1, a full range input will produce a 3V output.

OUTPUT REL: Selects value of input which represents 0V at output. The reference value can be either a programmed value or the value of the previous input.

DATA BUFFER

BUFFER TYPE: Linear or circular. Each location stores the reading and the time since the first trigger.

BUFFER MEMORY LENGTH: Programmable 1 to 1024 locations.

BUFFER STATISTICS: Number of Readings, Location, Value, Timestamp, Maximum Reading, Minimum Reading, Average and Standard Deviation.

TRIGGER

MODES: ONE SHOT or MULTIPLE readings per trigger.

INTERVAL: In MULTIPLE Mode, the time between readings can be programmed from 10ms to 999.999s in 1ms increments.

DELAY: Time between trigger and start of first measurement. Selectable from 0 to 999.999s in 1ms increments.

SOURCES: Rear panel BNC (EXTERNAL).
Front panel button (MANUAL).
IEEE-488 (GET, "X", or Talk).

IEEE-488 BUS IMPLEMENTATION

MULTILINE COMMANDS: DCL, LLO, SDC, GET, GTL, UNT, UNL, SPE, SPD.

UNILINE COMMANDS: IFC, REN, EOJ, SRQ, ATN.

INTERFACE FUNCTIONS: SH1, AH1, T6, TE0, L4, LE0, SR1, RL1, PP0, DC1, DT1, C0, E1.

PROGRAMMABLE PARAMETERS: All parameters programmable except for IEEE-488 bus address.

GENERAL

RANGING: Manual or autoranging. Measurement range is displayed.

CALIBRATION: Closed case. Internal ratiometric calibration of 3mV and 30mV ranges. Calibrator must provide 300mV, 3V, and 30V. Calibration can be done via the front panel or the IEEE-488 bus.

POWER-UP SETTINGS: Can be programmed by the user.

SELF-TEST: Tests Display, RAM, ROM and EEPROM.

DISPLAY: Vacuum fluorescent, two lines, 49 characters plus annunciators.

FRONT PANEL CONNECTOR: Special low thermal shielded connector.

REAR PANEL CONNECTORS: Analog output, External Trigger input, Meter Complete: BNC. IEEE-488 connector and BNC connectors are chassis grounded.

WARM-UP: 1 hour to rated accuracy.

ISOLATION: 350V peak from either input terminal to earth ground. Impedance from either terminal to earth ground is >1G Ω paralleled by <400pF.

SAFETY: Designed to IEC-348.

EMI/RFI: Meets VDE-0871 class B limits.

OPERATING ENVIRONMENT: 0°-35°C, <80% RH.

STORAGE ENVIRONMENT: -25° to 65°C.

POWER: 105-125V AC or 210-250 V AC (rear panel switch selectable). 90-110V AC or 180-220V AC version available. 50Hz or 60Hz, 35VA maximum.

DIMENSIONS: 90 mm high \times 213 mm wide \times 397 mm deep (3 1/2 in. \times 8 3/8 in. \times 15 5/8 in.).

WEIGHT: 3.4 kg (7.4 lbs).

ACCESSORIES SUPPLIED: Line cord, instruction manual, Quick Reference Guide.

CONFIGURATIONS:

182/1506 Includes triax cable terminated with copper alligator clips.

182/1507 Includes triax cable terminated with copper lugs.

182/1482 Includes shielded twisted pair cable, unterminated.

Specifications subject to change without notice.

SECTION 1

General Information

1.1 INTRODUCTION

This section contains general information about the Model 182 Sensitive Digital Voltmeter, and it is arranged in the following manner:

1.2 Features

1.3 Warranty Information

1.4 Manual Addenda

1.5 Safety Symbols and Terms

1.6 Specifications

1.7 Unpacking and Inspection

1.8 Repacking for Shipment

1.9 Optional Accessories

1.2 FEATURES

The Model 182 Sensitive Digital Voltmeter is a fully-programmable instrument with 1nV sensitivity. The Model 182 provides highly-accurate, stable, low-noise readings on five ranges for DC voltage measurements between 1nV and 30V.

Key features of the Model 182 include:

- Special input characteristics: Low common-mode current and RFI for minimal undesirable effects on sensitive circuits. Fast open input recovery places the input preamp in a nonsaturating state when the inputs are open while the instrument is in the one-shot mode.
- High-sensitivity, low-noise measurements: The Model 182 has a resolution of 1nV on the 3mV range at 6 1/2-digit resolution with only 15nV of noise.
- Selectable integration periods: Choice of 3msec, line cycle, and 100msec integration periods allows the best compromise between measurement speed, resolution, and noise.
- Standard IEEE-488 interface: The built-in IEEE-488 interface allows the instrument to communicate with and be controlled from a computer.
- 1,024 Reading Buffer: The 1,024-reading buffer can be programmed and data can be recalled from the front panel or over the IEEE-488 bus. The buffer can be programmed to store from 1 to 1,024 readings or on a continuous basis. Mean, maximum, minimum, and standard deviation values are also available.
- Analog output: The analog output, which supplies a 3V full scale analog of the measurement at the reading rate, is available on the rear panel. User-programmable gain and relative features for optimized use of external analog recording devices such as chart recorders.
- Digital filter: The 3-pole digital filter can be used to minimize reading noise. Filter response can be tailored for the best compromise between speed and noise reduction.

- **Reading Relative:** The relative feature can be used to null offsets to optimize measurement accuracy, or to store and subtract a baseline value from subsequent readings.
- **Digital calibration:** Allows easy calibration of instrument voltage measurements and the analog output without having to remove the top cover.

1.3 WARRANTY INFORMATION

Warranty information is located on the inside front cover of this instruction manual. Should your Model 182 require warranty service, contact the Keithley representative or authorized repair facility in your area for further information. When returning the unit for repair, be sure to fill out and include the service form at the back of this manual in order to provide the repair facility with the necessary information.

1.4 MANUAL ADDENDA

Any improvements or changes concerning the instrument or manual will be explained in an addendum included with the unit. Be sure to note these changes and incorporate them into the manual before using or servicing the instrument.

1.5 SAFETY SYMBOLS AND TERMS

The following symbols and terms may be found on an instrument or used in this manual.

The  symbol on an instrument indicates that the user should refer to the operating instructions located in the instruction manual.

The **WARNING** heading used in this manual explains dangers that might result in personal injury or death. Always read the associated information very carefully before performing the indicated procedure.

The **CAUTION** heading used in this manual explains hazards that could damage the unit. Such damage may invalidate the warranty.

1.6 SPECIFICATIONS

Model 182 specifications are located at the front of this manual.

1.7 UNPACKING AND INSPECTION

1.7.1 Inspection for Damage

Upon receiving the Model 182, carefully unpack it from its shipping carton and inspect the instrument for any obvious signs of physical damage. Report any such damage to the shipping agent immediately. Save the original packing carton for possible future shipment.

1.7.2 Shipment Contents

The following items are included with every Model 182 order:

- Model 182 Sensitive Digital Voltmeter
- Model 1482, 1506, or 1507 Low-Thermal Cable (depends on model ordered)
- Model 182 Instruction Manual.
- Additional accessories as ordered.

1.7.3 Instruction Manual

If an additional instruction manual is required, order the manual package, Keithley part number 182-901-00. The manual package includes an instruction manual and any applicable addenda.

1.8 REPACKING FOR SHIPMENT

Should it become necessary to return the Model 182 for repair, carefully pack the unit in its original packing carton or the equivalent, and include the following information:

- Advise as to the warranty status of the instrument.
- Write **ATTENTION REPAIR DEPARTMENT** on the shipping label.
- Fill out and include the service form located at the back of this manual.

1.9 OPTIONAL ACCESSORIES

Accessories that are recommended for use with the Model 182 are summarized below.

Model 1481 Low Thermal Input Cable — The Model 1481 is 1.2m (4 ft.) of shielded twisted pair cable terminated on one end with a Model 1486 Low Thermal Connector and two alligator clips on the other end.

Model 1482 Low Thermal Input Cable — The Model 1482 is similar to the Model 1481 and is made up of 3m (10ft.) of cable terminated with a Model 1486 Low Thermal Connector on one end and bare copper wires on the other end.

Model 1483 Low-Thermal Connection Kit — The Model 1483 contains a crimp tool, pure copper lugs, alligator clips, and assorted hardware.

Model 1484 Refill Kit — The Model 1484 includes the following replacement parts for the Model 1483: pure copper lugs, alligator clips, and assorted hardware.

Model 1485 Female Low Thermal Input Connector — The Model 1485 is the same as the front panel INPUT connector on the Model 182.

Model 1486 Male Low Thermal Connector — The Model 1486 mates with the front panel INPUT connector on the

Model 182, and it can be used to make a custom length input cable.

Model 1488 Low Thermal Shorting Plug — The Model 1488 is intended for checking proper operation and for calibration of the Model 182.

Model 1506 Low Thermal Input Cable — The Model 1506 is a 1.2m (4 ft) triaxial cable terminated with a low thermal mating connector to the Model 182 input on one end, and copper alligator clips on the other end.

Model 1507 Low Thermal Input Cable — The Model 1507 is similar to the Model 1506 except that it is terminated on one end with copper spade lugs instead of alligator clips.

Model 4228-1 Single Fixed Rack Mounting Kit — The Model 4228-1 can be used to mount one Model 182 in a standard 19 in. rack. This kit includes one rack ear, a dress panel, and hardware necessary for mounting. The Model 4228-1 is 8.8cm (3.5 in.) in height.

Model 4228-2 Dual Fixed Rack Mounting Kit — The Model 4228-2 can be used to mount two Model 182s or similar instruments side by side in a standard 19 in. rack. The Model 4228-2 Kit includes two rack ears, two middle brackets, and hardware necessary for mounting.

Model 7007 Shielded IEEE-488 Cables — The Model 7007-1 (1m, 3.3 ft.) and Model 7007-2 (2m, 6.6 ft.) IEEE-488 cables can be used to interface the Model 182 to the IEEE-488 bus.

SECTION 2

Getting Started

2.1 INTRODUCTION

This section contains introductory information on using your Model 182 Sensitive Digital Voltmeter. For detailed front panel and IEEE-488 bus operation, refer to Sections 3 and 4 respectively.

The information in this section is arranged as follows:

2.2 Front and Rear Panel Configuration: Summarizes the controls, displays, and connectors on the front and rear panels of the instrument.

2.3 Basic Front Panel Operation: Gives the procedure for making basic measurements using the front panel controls.

2.4 Basic Menu Operation: Summarizes the basic operation of the front panel MENU key and available menu selections.

2.5 Basic Buffer Operation: Describes fundamental steps necessary to store and recall buffer data.

2.6 Basic IEEE-488 Operation: Covers basic operation of the instrument over the IEEE-488 bus.

2.2 FRONT AND REAR PANEL CONFIGURATION

Figure 2-1 shows the front panel of the Model 182, and Figure 2-2 shows the rear panel.

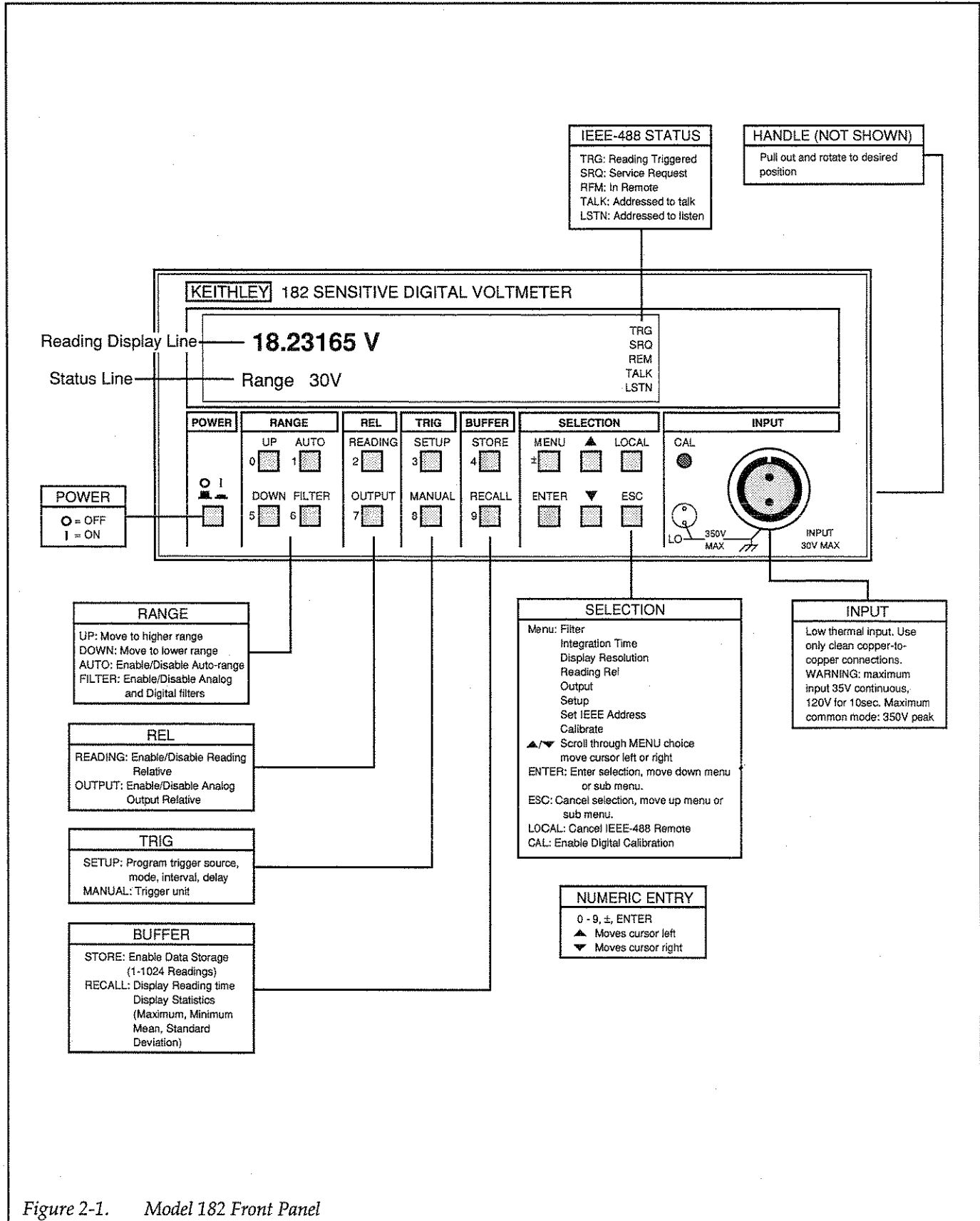

Figure 2-1. Model 182 Front Panel

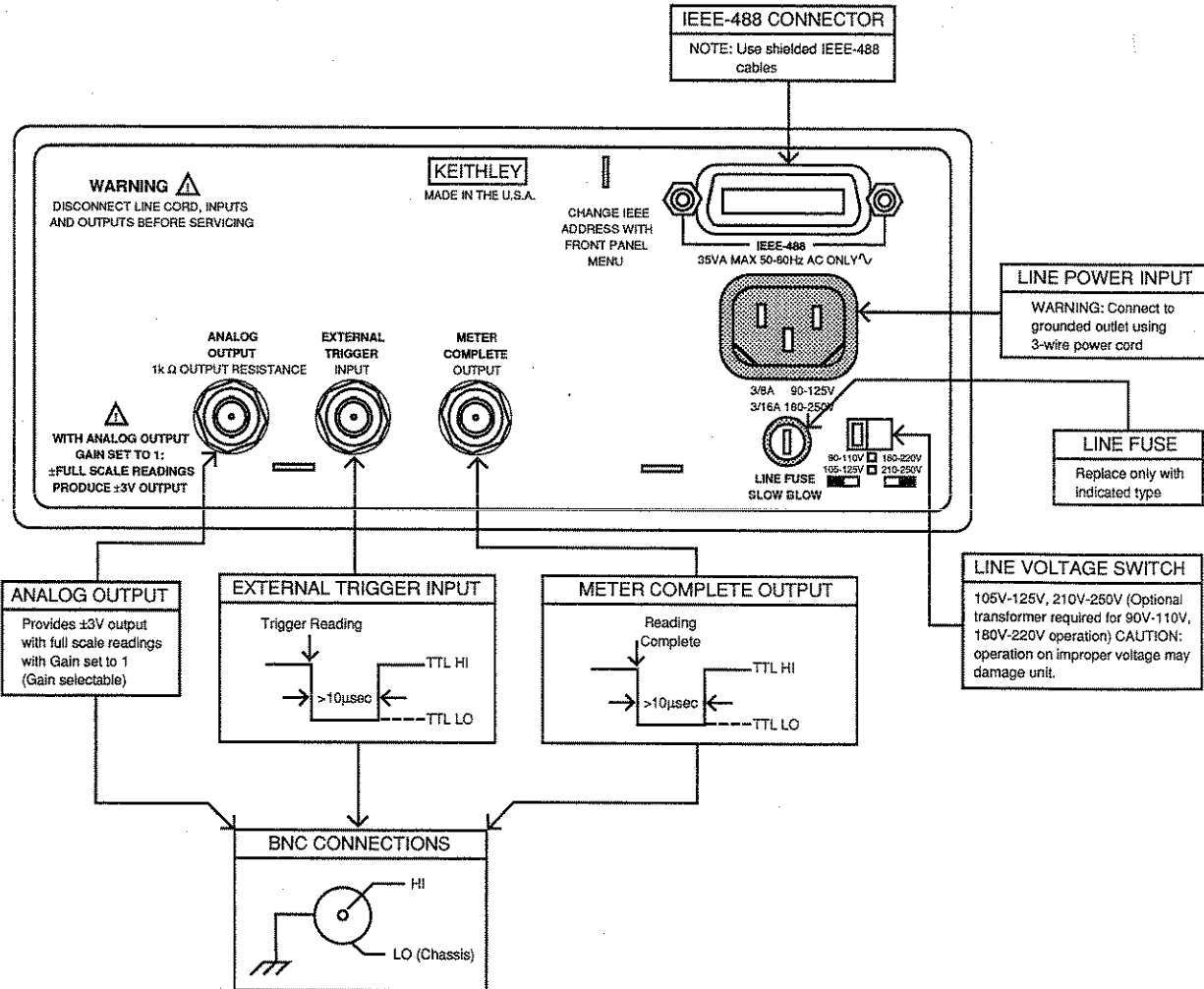

Figure 2-2. Model 182 Rear Panel

2.3 BASIC FRONT PANEL OPERATION

2.3.1 Basic Measurement Procedure

Follow the basic procedure below to make voltage measurements with the Model 182.

1. Make sure the line voltage switch on the rear panel is in the correct position for the power line voltage to be used. Plug the instrument into a grounded power receptacle using the supplied power cord or the equivalent.

WARNING

The Model 182 must be powered from a grounded outlet to avoid a possible shock hazard.

CAUTION

Using the Model 182 on an incorrect line voltage may result in damage to the instrument.

2. Turn on the Model 182 by pressing the front panel POWER switch. Allow a one-hour warm-up period for rated accuracy.
3. Select the desired measurement range manually with the UP RANGE or DOWN RANGE button, or select auto-ranging if desired by pressing AUTO. When using manual ranging, be sure to use a range high enough for the expected voltage.
4. Select other front panel operating modes such as filter, as required. Refer to Section 3 for detailed information on using these features.
5. Connect the supplied low-thermal input cable to the front panel INPUT connector, and secure it with the locking ring.
6. To null offsets, short the free end of the input cable, and allow the reading to settle. Press REL READING to enable the zero reading feature and null any offsets. Leave zero enabled while making measurements.
7. Connect the source to be measured to the low-thermal cable that is connected to the front panel INPUT connector. See Figure 2-3 for typical connections.

WARNING

Maximum common-mode voltage (voltage between input LO and chassis ground) is 350V peak. Exceeding this value may create a shock hazard.

CAUTION

Maximum allowable input voltage is 120V for 10 seconds, 35V continuous. Exceeding these levels may cause damage to the instrument.

8. Note the reading on the display. If the OVERFLOW message is displayed with the instrument on a manual range, select the next higher range until you obtain an on-range reading. Use the lowest possible range to obtain the best accuracy and resolution.
9. Note the voltage reading on the display, which will show DC volts or DC millivolts along with polarity sign (–, + is implied). A mV or V suffix will be displayed as appropriate for the selected range.

2.3.2 Low-level Measurement Considerations

Measurements of signal voltages in the nV and μ V range are particularly susceptible to the effects of noise and thermal EMFs. The paragraphs below briefly discuss the most important aspects of these effects. For more detailed information on these and other important measurement considerations, refer to paragraph 3.12 in Section 3.

Noise

AC voltages that are large in relation to the measured DC signal may produce an erroneous DC output signal that corrupts the measurement. The most obvious signs of possible noise include:

- Unstable, varying readings
- Unexpected offset voltages
- Inconsistent readings between measurement ranges
- Sudden shifts in readings

To minimize noise pickup, keep the Model 182, signal leads, and voltage source as far away as possible from noise sources such as power transformers. Also, keep the loop area formed by the input leads as small as possible, and shield the voltage source as appropriate. The shield should generally be connected to input LO, but better noise performance may be obtained by connecting the shield to chassis ground in some cases.

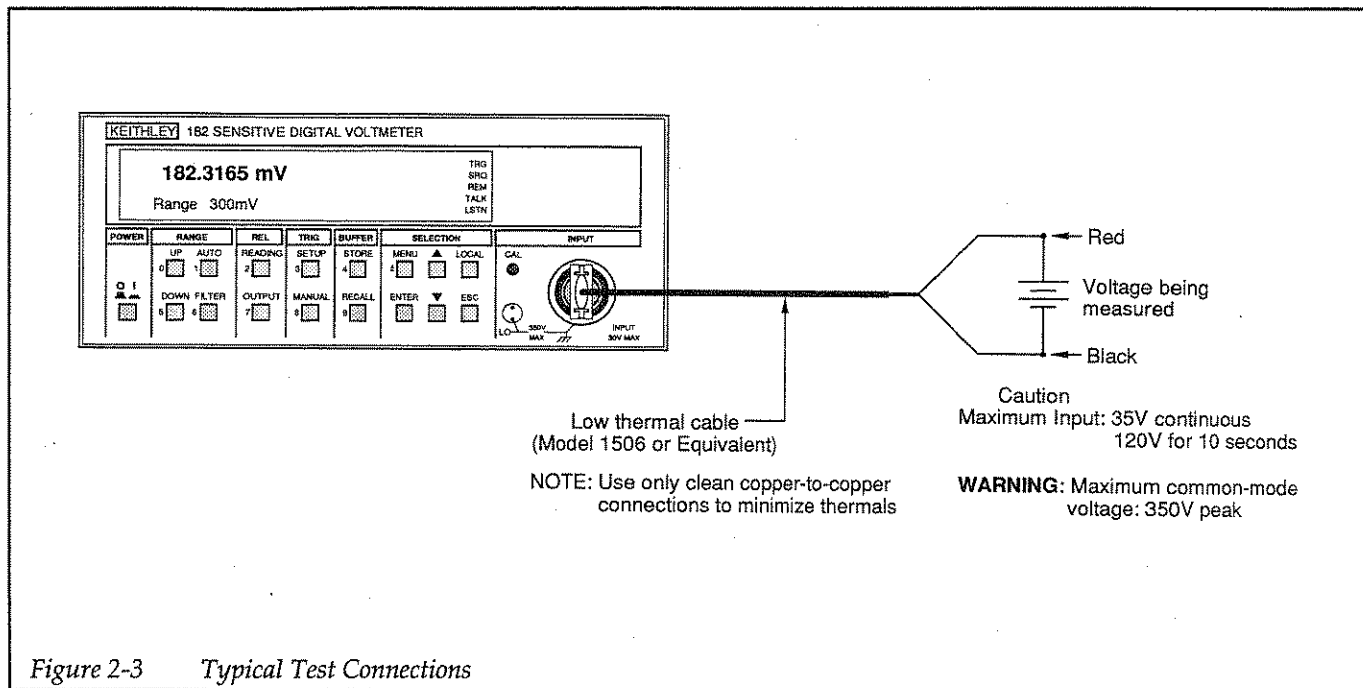

WARNING
Do not float input LO more than 30V RMS, 42.4V peak above earth ground when an exposed shield is connected to input LO. To avoid a possible shock hazard, surround the LO shield with a second, safety shield that is insulated from the inner shield. Connect this safety shield to safety earth ground using #18 AWG minimum wire before use.

- Use the REL READING control to null out constant offsets. Use relative often to minimize the effects of thermal drift.

Thermal EMFs

Thermal EMFs (thermoelectric potentials) are small voltages generated by temperature differences at the junctions of dissimilar metals. The presence of such thermal offsets should be suspected if the instability or zero offset is higher than expected, or if the reading is affected by circuit temperature changes.

Thermal offsets can be minimized as follows:

- Use only clean copper wires, connectors, and lugs for all connections.
- Keep the temperature of the measured circuit as constant as possible.
- Keep all devices associated with the measurement away from air currents.

2.4 BASIC MENU OPERATION

The following paragraphs give a brief overview of MENU key operation. For complete details on using the MENU key and the various MENU items, refer to paragraph 3.11 in Section 3.

2.4.1 MENU Summary

Table 2-1 summarizes the features that you can access through the MENU key. Active menu keys include:

- | | |
|--------|---|
| MENU | Enters menu. |
| ▲ or ▼ | Scrolls through menu selections, moves cursor. |
| 0-9, ± | Enters numeric parameters. |
| ENTER | Enters menu selection or entry. |
| ESC | Cancels changed menu selection, returns to previous menu level. |

Table 2-1 MENU Summary

MENU Message	DESCRIPTION
FILTER	Digital filter response, analog filter on/off
INTEGRATION TIME	Set integration rate, (3msec, line cycle, 100msec)
DISPLAY RESOLUTION	Set display resolution (3 ¹ / ₂ , 4 ¹ / ₂ , 5 ¹ / ₂ , 6 ¹ / ₂ digits)
READING REL	Program reading relative value (1nV – 30V)
OUTPUT	Set analog output gain and relative value
SETUP	Save/recall instrument setups
SET IEEE ADDRESS	Set primary address (0–30)
CALIBRATE	Display test, calibrate unit, configure analog output

2.4.2 Accessing MENU Items

1. Press the MENU key to enter the main menu.
2. Press the ▲ or ▼ key to scroll through the main menu items summarized in Table 2-1. For example, press ▼ once to access the integration time.
3. Press ENTER to select a main menu item.
4. For those levels such as IEEE address that require numeric parameters, key in the desired numbers using the numeric entry keys (0-9).
5. For those menu levels with a list of choices (for example, resolution), use the ▲ or ▼ key to scroll through the available choices.
6. To cancel your selection without making a change, press ESC. Pressing ESC will also return you to the previous menu level (where applicable).
7. To accept your new entry or selection, press ENTER. Doing so will also take you down to the next lower menu level if one exists.
8. After completing all your menu choices, press ESC as many times as necessary to return to normal reading display.

2.5 BASIC BUFFER OPERATION

The Model 182 data buffer can be used to store up to 1,024 readings at given intervals for later recall. Recall features include buffer location and time stamp, as well as statisti-

cal functions such as mean, minimum, maximum, and standard deviation.

Basic operation of the data store buffer is summarized below. For detailed information on using the buffer, refer to paragraph 3.10 in Section 3.

2.5.1 Storing Data

1. Setup the Model 182 to measure the expected voltage, and connect the instrument to the voltage source to be measured.
2. Press the STORE button, then enter the desired number of readings to store using the numeric entry keys (0-9). Enter 1 to 1,024 for linear storage (buffer fills and then stops when the programmed number of readings have been stored), or enter a value of 0000 for continuous storage (buffer wraps around and overwrites old readings when full).
3. Press ENTER to complete entry and to begin data storage (or press ESC to cancel the process and return to normal display).
4. The STORE LED will flash to indicate that data storage is enabled. You can turn off data storage during the storage process by pressing STORE.
5. The STORE LED will turn on steadily to indicate when the buffer is full (the programmed number of readings have been stored) except for continuous mode.

2.5.2 Recalling Normal Readings, Location, and Time

During or after the data storage process, you can recall the reading and time stamp information at specific locations using the procedure below.

1. Press the RECALL button to enter the recall mode.
2. Press the ENTER key.
3. The unit will display the last reading stored along with the location number on the reading line, and the time stamp on the bottom (status) line of the display.
4. Press the ▲ or ▼ key to scroll through buffer locations. Both buffer location and time stamp information will be updated as you scroll through locations.
5. To randomly access a specific buffer location number, press a number key (0-9), then key in the desired location number. Press ENTER to view the selected location. You can then continue to scroll through locations by using ▲ or ▼.
6. Press ESC twice to return to normal reading display.

2.5.3 Recalling Statistics

Follow the steps below to display the number of samples stored in the buffer, as well as maximum, minimum, mean (average), and standard deviation values.

1. Press RECALL to enter the buffer recall mode.
2. Press ▲ or ▼ to display the "Recall-Statistics" message, then press ENTER.
3. Use the ▲ or ▼ key to scroll through the number of samples, maximum, minimum, and average values, and the standard deviation.
4. Press ESC twice to return to normal display.

2.6 BASIC IEEE-488 OPERATION

The following paragraphs discuss fundamental information concerning IEEE-488 bus operation that will allow you to get started using your instrument over the bus and perform simple measurement tasks. For detailed information on using the Model 182 over the bus, refer to Section 4.

2.6.1 Bus Connections

Before using the instrument over the bus, you must connect the IEEE-488 connector on the rear panel of the instrument to the IEEE-488 connector of your controller. Use a Keithley Model 7007 or similar shielded IEEE-488 cable in order to minimize the possibility of electrical interference.

2.6.2 Primary Address

The primary address of the Model 182 must agree with the primary address you intend to specify in the controller's programming language. The factory setting for the primary address is 7, so if you intend to use that address, you need not change it. However, the primary address can be set to any value between 0 and 30 by using the address selection menu available with the MENU key.

2.6.3 Abbreviated Command Summary

Table 2-2 is an abbreviated list of available commands, which will allow you to program basic operations such as range, display resolution, digital filtering, and reading zero. Note that the X character must be included in the command string to execute commands.

2.6.4 Example Program

The example program below, which is written in Hewlett-Packard BASIC 4.0, will allow you to send commands to the Model 182 and display the reading data on the computer CRT. Note that the program assumes that the instrument is set to its default primary address of 7. Additional controller programs are located in Appendix D.

Follow the steps below to use this program.

1. With the power off, connect the Model 182 to the IEEE-488 bus of the computer.
2. Turn on the instrument, and verify that the primary address is set to 7 (the primary address is displayed as part of the power-up cycle). If necessary, use the MENU key to program the primary address to 7.
3. Turn on the computer, then boot up BASIC.
4. Enter the lines from the program below into the computer.
5. RUN the program in the usual manner.

Table 2-2 Abbreviated Command Summary

Command	Description
B0	5 1/2-digit display resolution
B1*	6 1/2-digit display resolution
B2	3 1/2-digit display resolution
B3	4 1/2-digit display resolution
D0*	Filter damping off
D1	Filter damping on
N0	Filters off
N1*	Filters on
O0*	Analog filter off
O1	Analog filter on
P0	Digital filter off
P1	Digital filter, fast response
P2*	Digital filter, medium response
P3	Digital filter, high response
R0	Auto-range on
R1	3mV range
R2	30mV range
R3	300mV range
R4	3V range
R5*	30V range
R6	No function
R7	No function
R8	Auto-range off
S0*	Line cycle integration
S1	Medium integration rate
S2	Fast integration rate
X	Execute other commands
Z0*	Reading relative off
Z1	Reading relative on
Z2,value	Reading relative on, use value
Z3	Reading relative on, use previous value

* Indicates factory default power-up states
NOTE: X (execute) required for unit to execute commands.

- Type in the desired command at the command prompt, then press Enter. For example, type in R4X to select the 3V measurement range.
- The instrument reading string will then be displayed. A typical example is: NDCV+1.238975E+00.

See paragraph 2.6.5 below for additional programming examples.

Program	Comments
10 REMOTE 707	! Put 182 in remote.
20 DIM C\$[100], R\$[100]	! Dimension command, reading strings.
30 LINPUT "Command",C\$! Input desired command string.
40 OUTPUT 707 ; C\$! Send command string.
50 ENTER 707 ; R\$! Get reading string.
60 PRINT R\$! Display reading string.
70 GOTO 30	! Loop back for next command.
80 END	

2.6.5 Programming Examples

Use the example program from the previous paragraph (or other similar program) to demonstrate the programming examples below. Simply type in the indicated command string at the command prompt and note the result by observing the front panel of the instrument.

Example 1: Program unit to 3V range.

The R command controls the manual measurement range of the instrument. To select a manual range, you must include the appropriate numeric command option with the R command as in the example below.

Command: R4X

Result: unit goes to 3V range (front panel status line shows: Range = 3V).

Example 2: Program auto-ranging.

The R0 and R8 commands are used to enable and disable auto-ranging, as the following example demonstrates.

Command: R0X

Result: Instrument goes to auto-range.

Command: R8X

Result: Auto-range is cancelled, and unit stays on present range.

Example 3: Select 4 1/2-digit resolution.

To select display resolution, simply send the B command followed by the numeric option representing the desired resolution, as in the following example.

Command: B3X

Result: 4 1/2-digit display resolution selected.

Example 4: Enable reading relative.

To enable the reading relative feature, send the Z command as the example below demonstrates.

Command: Z1X

Result: Reading relative is enabled.

Example 5: Sending multiple commands.

You can send multiple commands in one string and execute them by including the X character as the last character in the command string. For example, assume that you wish to select the 30V range, program 6 1/2-digit resolution, and enable reading relative, all in the same command string. The example below demonstrates the command sequence to select these operating parameters.

Command: R5B1Z1X

Result: The instrument changes to the 30V range and 6 1/2-digit resolution with reading relative enabled.

SECTION 3

Operation

3.1 INTRODUCTION

This section contains detailed information on front panel operation of the Model 182, and it is organized as follows:

3.2 Power-up Procedure: Covers information on line voltage selection, connecting the unit to line power, warm-up period, default conditions, and power-up sequence.

3.3 Test Connections: Covers recommended cables and typical test connections.

3.4 Display: Covers display format and messages that may appear while using the instrument.

3.5 Range: Covers both manual and auto-ranging operation.

3.6 Triggering: Details types of trigger modes as well as trigger sources that can be used.

3.7 Filter: Covers use of the analog and digital filters that can be used to reduce reading noise.

3.8 Reading Relative: Gives details on using the relative feature that can be used to null offsets or subtract a baseline value from current and future readings.

3.9 Analog Output: Describes use of the rear panel analog output including connections, programming gain, and using analog output relative.

3.10 Buffer Operation: Covers use of the 1024-reading buffer including programming buffer size and recalling data, time stamp, and statistics information.

3.11 Menu: Summarizes various instrument menu functions such as IEEE-488 primary address, resolution, integration rate, saving and recalling setups, filter, and analog output gain.

3.12 Measurement Considerations: Discusses a number of measurement considerations such as thermal EMFs, noise, shielding, and source resistance.

3.13 Applications: Outlines typical Model 182 applications such as low-resistance measurements and low-voltage scanning.

3.2 POWER-UP PROCEDURE

3.2.1 Line Power Connections

Follow the procedure below to connect the Model 182 to line power and turn on the instrument.

1. First check to see that the line voltage selection switch on the rear panel is in the correct position for the operating voltage in your area. The factory setting is marked on the rear panel adjacent to the line voltage selection switch. Available voltage ranges are 105V-125V or 210V-250V 50/60Hz AC (90-110V, 180-220V with optional internal power transformer). If necessary, set the line voltage selection switch to the correct position.

CAUTION

Operating the instrument on an incorrect line voltage may cause damage to the instrument, possibly voiding the warranty.

2. Before plugging in the power cord, make sure the front panel power switch is in the off (0) position.
3. Connect the female end of the supplied power cord to the AC receptacle on the rear panel. Connect the other end of the power cord to a grounded AC outlet.

WARNING

The power cord supplied with the Model 182 contains a separate ground wire designed to be used with grounded outlets. When proper connections are made, instrument chassis is connected to power line ground through the ground wire in the power cord. Failure to use a grounded outlet may result in personal injury or death because of electric shock.

3.2.2 Power-up Sequence

Turn on instrument power by pressing in on and releasing the front panel POWER switch. Upon power up, the instrument will perform a self-test on RAM, ROM, and E²ROM circuits. If an E²ROM fault occurs, however, an UNCALIBRATED message will be displayed. In this case, the instrument is still usable, but readings will probably be inaccurate.

As part of the power-up cycle, the instrument will first display the model number and firmware revision levels for the main microprocessor and the two micro-controllers:

MODEL 182 SDV
A01 A01 A01

The three firmware revision levels (left to right) are for the main microprocessor, the A/D converter, and front panel microcontroller. The revision level number in this example is A01 and may be different in your particular unit.

Next, the unit will display the IEEE-488 primary address and power line frequency:

IEEE ADDRESS = 07
Frequency = 60 Hz

In this example, the IEEE-488 address is its default value of 7, and the line frequency is 60Hz (the operating line frequency is automatically determined).

After the power-up sequence, the instrument will begin normal display, for example:

00.00000 V
Range 30 V

3.2.3 Default Conditions

Default conditions are those conditions the instrument will assume when it is first turned on. Table 3-1 lists the default conditions as set at the factory. You can change these default conditions (except the primary address) by using the save setup feature available with the MENU button, as described in paragraph 3.11.

Table 3-1 Factory Default Conditions

Description	Default State
Range	30V, auto-range off
Reading Relative	Off, value = 0V
Analog Filter	Off
Digital Filter	On, medium response
Buffer	Off, size = 0000 (wrap around)
Analog Output	Relative off, value: 0V, gain: 1.0, normal output, source value = 0V
Primary Address	7
Integration Period	Line cycle (16.67msec @ 60Hz, 20msec @ 50Hz)
Display Resolution	6 1/2 digits
Trigger Mode	Multiple
Trigger Source	External (MANUAL key also operative)
Trigger Interval	0.25sec
Trigger Delay	0sec
Calibration Lock	On (calibration locked)

NOTE: All listed operating states except buffer status, primary address, and calibration lock status can be saved as user configuration (paragraph 3.11.6). Primary address can be saved using separate menu item (paragraph 3.11.7).

3.2.4 Warm-up Period

The Model 182 can be used immediately after it is turned on. However, the instrument should be turned on and allowed to warm up for at least one hour before use to achieve rated accuracy.

After warm-up, you should use REL READING often to minimize the effects of thermal drift.

3.2.5 IEEE-488 Primary Address

The IEEE-488 primary address of the instrument must be the same as the primary address you specify in the controller's programming language. The default primary address of the instrument is 7, but you can set the address to any value from 0 to 30 by using the MENU button. Refer to paragraph 3.11.7 for step-by-step instructions on setting the primary address; Section 4 contains details on using the Model 182 over the IEEE-488 bus.

3.3 TEST CONNECTIONS

3.3.1 Recommended Cables

For optimum measurement accuracy, use only low-thermal connecting cables such as the Model 1506 or similar

cable. Paragraph 1.9 lists recommended cables and other accessories in detail. To minimize thermals, keep all connections clean and free of oxides (see paragraph 3.12.1).

3.3.2 Typical Test Connections

Figure 3-1 shows typical test connections to the Model 182.

WARNING

Maximum common-mode voltage (voltage between input LO and chassis) is 350V peak. Exceed this value may create a shock hazard.

CAUTION

Maximum input is 120V for 10 seconds, 35V continuous. Exceeding these values may cause damage to the instrument.

When measuring low-level signals, it may be necessary to shield the voltage source in order to minimize noise. As shown in Figure 3-1, this shield should be connected to INPUT LO in most cases, but better noise performance may be obtained by connecting the shield to chassis ground in some cases.

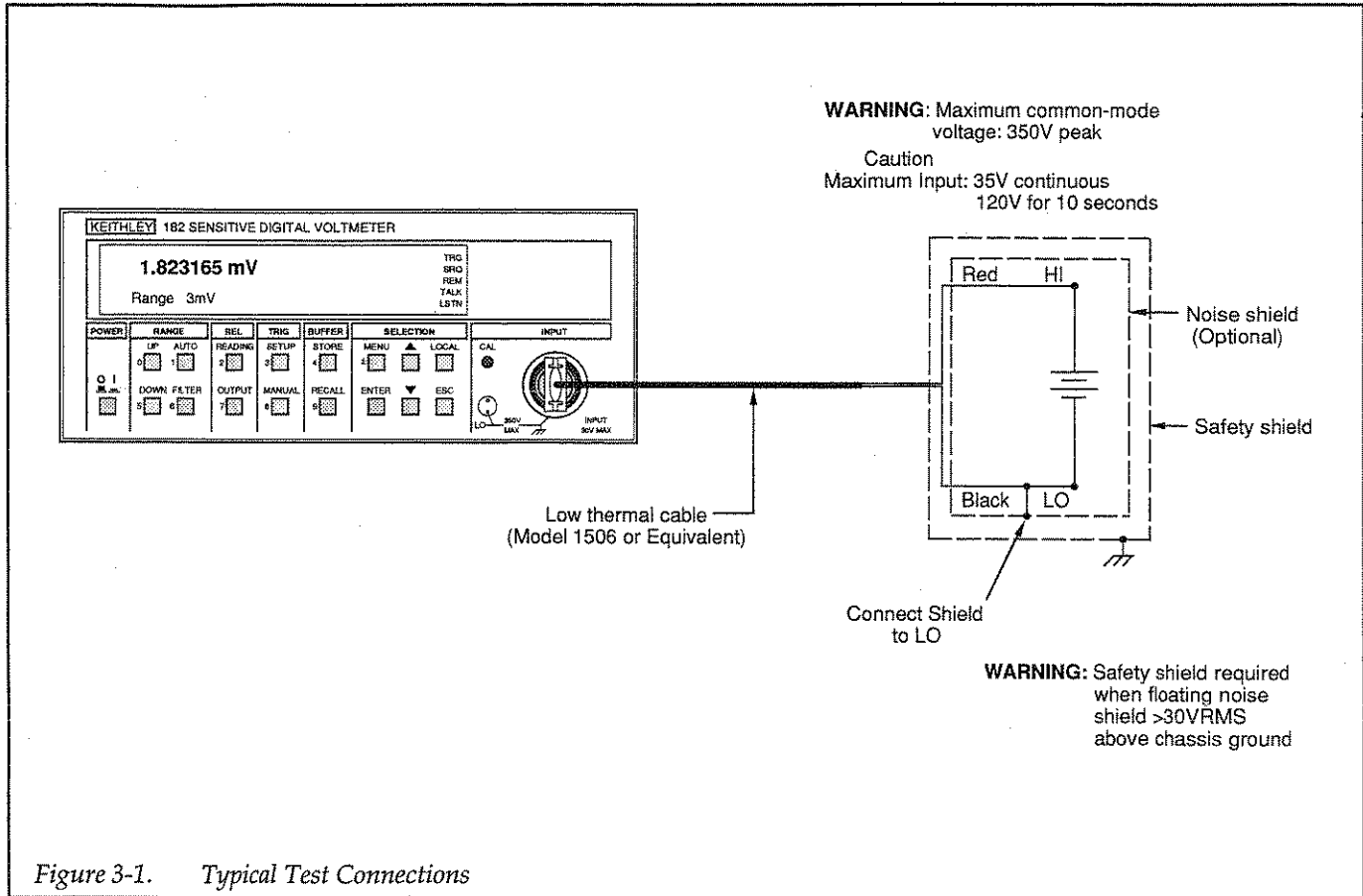

Figure 3-1. Typical Test Connections

WARNING
If the shield is to be floated more than 30V RMS, 42.2V peak above chassis ground, the shield must be surrounded with a safety shield. This safety shield must be connected to safety earth ground using #18 AWG minimum wire.

3.4 DISPLAY

3.4.1 Display Format

As shown in Figure 3-2, the front panel has two lines of display information. The top line displays the present reading, except when the unit is displaying a menu item, a buffer item, or is displaying certain informational or error messages. The bottom line is a status line.

Reading Line

The reading line displays readings with 3 1/2, 4 1/2, 5 1/2, or 6 1/2 digits, depending on the selected display

resolution (you can select the resolution by using the DISPLAY RESOLUTION selection available with the MENU key).

The reading line also displays menu and buffer messages when these features are activated, as well as error and IEEE-488 bus messages. Refer to paragraphs 3.10 and 3.11 for details on buffer and menu operation.

Status Line

Normally, this line displays the presently-selected range for both manual and auto-range operation (the AUTO indicator will be on when auto-range is selected). For example, on the 300mV range, the status line will display:

Range 300mV

The status line also displays messages when accessing buffer or menu items, and it also displays the time stamp and other information when recalling buffer data. The status line also displays useful error information.

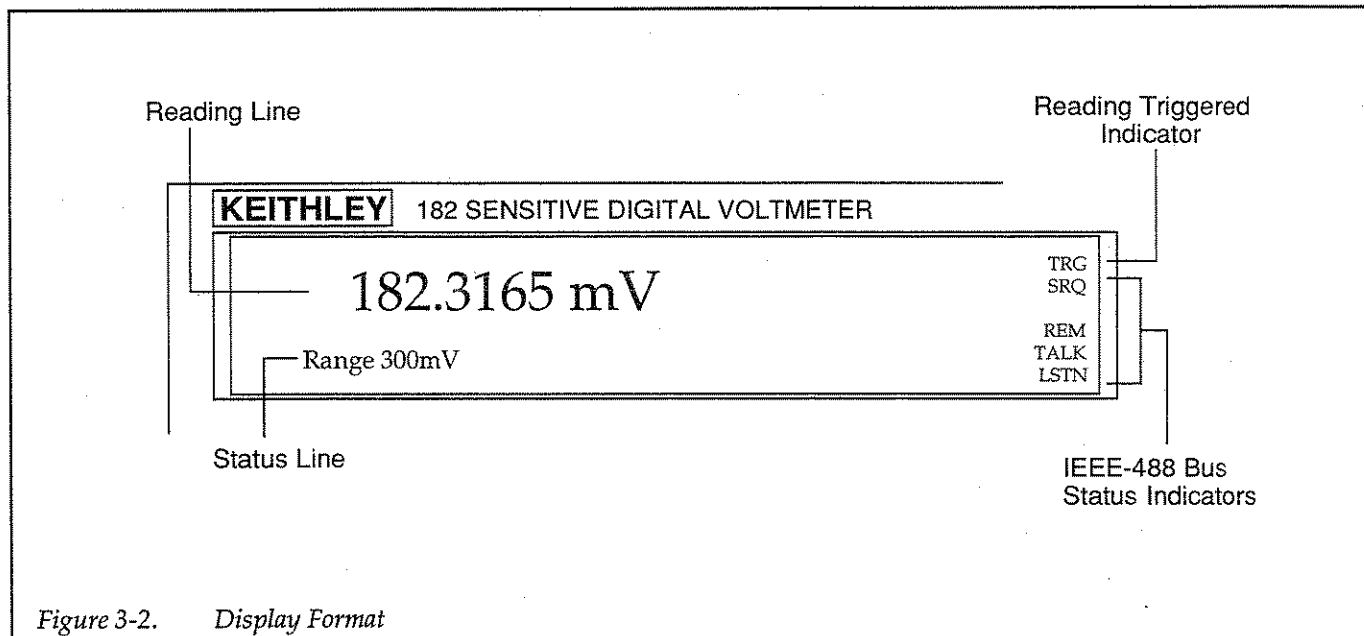

Figure 3-2. Display Format

Annunciators

The five annunciators at the right of the display indicate the following conditions:

TRG: When the interval between readings is greater than 300msec, TRG turns on when a reading has been triggered and has begun processing, and it turns off when a reading is done. If the time interval between readings is 300msec or less, TRG stays on continuously.

SRQ: turns on when the unit requests service over the IEEE-488 bus. The IEEE-488 bus M command allows you to control which conditions will generate an SRQ (see paragraph 4.2.12).

REM: indicates the Model 182 is in remote when used over the IEEE-488 bus. The Model 182 can be placed in remote by addressing it to listen with the bus REN line true.

TALK: shows the Model 182 is the active talker on the IEEE-488 bus. The unit can be placed in the talker active state by sending it the correct bus talk command, which is derived from the primary address.

LSTN: turns on when the unit is an active IEEE-488 bus listener. The Model 182 can be placed in the active listener state by addressing it to listen.

3.4.2 Display Error Messages

Error messages that may occur during operation are summarized in Table 3-2. Some of these errors such as INVALID COMMAND and INVALID OPTION can occur only while programming the Model 182 over the IEEE-488 bus. The error number corresponds to the pertinent bit position in the U1 error word, which is covered in paragraph 4.2.20.

Table 3-2 Error Messages

U1 Bit*	Display Message	Description	Type
0**	INVALID COMMAND	Invalid Device-Dependent Command	Momentary
1**	INVALID OPTION	Invalid Device-Dependent Command Option	Momentary
2**	INVALID FORMAT	Invalid Device-Dependent Command Format	Momentary
3**	NOT IN REMOTE	Unit not in remote when programmed	Momentary
4	TRIGGER OVERRUN	Unit triggered while processing reading (one-shot only)	Momentary
5	OVERFLOW	Input signal too large for range	Momentary
6	NVRAM ERROR	NVRAM error found during self-test	Latching
7	RAM ERROR	RAM error found during self-test	Latching
8	UNCALIBRATED Press a key to continue	Unit not calibrated	Latching
9	CAL RUNNING	Invalid command or operation when calibration unlocked	Momentary
10	CAL LOCKED	Calibration attempted with calibration locked	Momentary
11	CAL ERROR Press a key to continue	Improper calibration value for applied signal	Latching
12	N/A	Reserved	
13	N/A	Reserved	
14	FRONT PANEL FAILURE	Front panel microcontroller communications failure	Latching
15	A/D COM FAILURE	A/D microcontroller communications failure	Latching
16	TRIGGER NOT READY	Unit still processing previous trigger	Momentary
17	N/A	Reserved	
18	N/A	Reserved	
19	N/A	Reserved	
20	N/A	Reserved	

* Indicates bit position in U1 error word. See paragraph 4.2.20.

** These errors pertain to IEEE-488 bus operation only. INVALID OPTION and INVALID FORMAT errors also display further error information on lower line of display. See paragraph 4.5.1.

Error messages are of two general types: momentary or latching. A momentary error will appear on the display for about two seconds, after which the display will automatically return to normal. A latching error will stay on the display until a key is pressed (the instrument will display an appropriate message to press a key on the status line).

These errors are further describe below:

INVALID COMMAND — The instrument has received an Invalid Device-Dependent Command over the IEEE-488 bus (see paragraph 4.5.1).

INVALID OPTION — The unit has received an Invalid Device-Dependent Command Option over the bus. The specific type of INVALID OPTION error will also be displayed (paragraph 4.5.1).

INVALID FORMAT — The Model 182 has received a device-dependent command string with an invalid format over the bus. Further information pertaining to the type of error will also be displayed (paragraph 4.5.1).

NOT IN REMOTE — An attempt was made to send a device-dependent command over the bus while the instrument was not in remote (see paragraph 4.5.1).

TRIGGER OVERRUN — The Model 182 was triggered while still processing a reading from a previous trigger. The TRIGGER OVERRUN error can occur only in the one-shot trigger mode.

OVERFLOW — The input signal is too large for the present measurement range.

NVRAM ERROR — An error was found with the NVRAM during the self-test. This error indicates a hardware failure that requires service.

RAM ERROR — An error was found with the RAM during the self-test. This error indicates a hardware failure that requires service.

UNCALIBRATED — Either the calibration constants are corrupted, or the Model 182 was never properly calibrated. In either case, the instrument can be used, but measurements will probably not be accurate.

CAL RUNNING — An invalid condition occurred while calibration was unlocked. Valid conditions during calibration include:

- Sending the following bus commands: A, C, G, K, R, U, Y
- Locking calibration with the CAL switch
- Entering calibration mode
- Changing range from the front panel (except auto-range)
- Changing the IEEE-488 primary address from the front panel

CAL LOCKED — Calibration was attempted with calibration locked. Calibration lock/unlock is controlled with the front panel CAL button.

CAL ERROR — The applied calibration signal is out of the allowed range for the programmed calibration value. The applied calibration signal should agree with the value entered during the calibration program.

FRONT PANEL FAILURE — No communications between the main microprocessor and the front panel microcontroller. Servicing is required if this error occurs.

A/D COM FAILURE — No communications between the main microprocessor and the A/D converter microcontroller. Servicing is required if this error occurs.

TRIGGER NOT READY — A trigger was received, but it cannot yet be processed because the instrument is still busy processing the last command (see paragraph 4.5.1).

3.5 RANGE

The selected measurement range affects both the ultimate resolution and accuracy of the measurement as well as the maximum signal voltage that can be measured. The following paragraphs discuss range resolution and manual and auto-range operation.

3.5.1 Display Resolution

The display resolution of a Model 182 reading depends both on the selected range as well as the display resolution setting and the programmed integration period. Table 3-3 summarizes the display resolution for each range at 3 1/2 digit, 4 1/2 digit, 5 1/2 digit, and 6 1/2-digit settings. You can set the display resolution, as described in paragraph 3.11.2.

NOTE

The maximum usable resolution is determined by the programmed integration period. The maximum usable resolution for 3msec, line cycle integration, and 100msec periods is 4 1/2 digits, 6 1/2 digits, and 6 1/2 digits respectively. See paragraph 3.11 for details on setting the integration period.

3.5.2 Maximum Readings

Table 3-4 summarizes maximum display reading listed by range. Input values more than the maximum reading

Table 3-3. Display Resolution

Range	Display Resolution			
	3 1/2d	4 1/2d	5 1/2d	6 1/2d
3mV	1μV	100nV	10nV	1nV
30mV	10μV	1μV	100nV	10nV
300mV	100μV	10μV	1μV	100nV
3V	1mV	100μV	10μV	1μV
30V	10mV	1mV	100μV	10μV

listed will cause the OVERFLOW message to be displayed.

3.5.3 Manual Ranging

To select a manual range, simply press the UP RANGE or DOWN RANGE key. Press UP to move uprange, or press DOWN to move downrange. The instrument will change one range per key press, or you can hold down the key to auto-repeat. Once the highest or lowest range has been selected, pressing the corresponding key will have no further effect. The selected range will be indicated on the status line of the display.

If the instrument displays the OVERFLOW message on a particular range, select a higher range until an on-range reading is displayed. Use the lowest range possible without causing an overflow to assure best accuracy and resolution.

Table 3-4. Maximum Readings

Range	Display Resolution			
	3 1/2d	4 1/2d	5 1/2d	6 1/2d
3mV	±3.029mV	±3.0299mV	±3.02999mV	±3.029999mV
30mV	±30.29mV	±30.299mV	±30.2999mV	±30.29999mV
300mV	±302.9mV	±302.99mV	±302.999mV	±302.9999mV
3V	±3.029V	±3.0299V	±3.02999	±3.029999V
30V	±30.29V	±30.299V	±30.2999	±30.29999V

3.5.4 Auto-ranging

To enable auto-ranging, press the AUTO key. The integral AUTO indicator will turn on when auto-ranging is selected. While auto-ranging is selected, the instrument will automatically choose the best range to measure the applied signal. The instrument will also display the present range in the range field of the status line.

Note that up-ranging occurs at the overflow point (± 3029999 counts), while down-ranging occurs at the following values:

Range	Down-Range Value
30V	2.8V
3V	280mV
300mV	28mV
30mV	2.8mV

To cancel auto ranging, press AUTO or the UP or DOWN key. Pressing AUTO to cancel auto range will leave the instrument on the present range.

3.6 TRIGGERING

A trigger is a stimulus that initiates a single reading in the one-shot trigger mode, or an unending series of readings in the multiple trigger mode. The paragraphs below discuss trigger modes, trigger sources, trigger interval and delay, and give procedures for triggering instrument readings.

3.6.1 TRIG SETUP

The TRIG SETUP up key allows access to the trigger setup menu, which allows you to set the following trigger aspects:

TRIGGER SOURCE: the stimulus that triggers readings.

TRIGGER MODE: multiple or one-shot

TRIGGER INTERVAL: the time period between readings in multiple

TRIGGER DELAY: the time between the trigger and reading in one-shot, or between trigger and start of readings at trigger interval in multiple.

Each of these aspects is covered in detail in the following paragraphs.

3.6.2 Trigger Sources

Available Trigger Sources

Available trigger sources include:

- Front panel MANUAL button
- External trigger pulse applied to EXTERNAL TRIGGER INPUT
- IEEE-488 bus trigger commands (X, talk, and GET)
- IEEE-488 bus manual (H0) command

Table 3-5 summarizes the available trigger sources and display messages.

NOTE

The front panel MANUAL button and the IEEE-488 bus H0 command are always active regardless of the selected trigger source except when the trigger source is disabled.

Table 3-5. Trigger Sources and Messages

Trigger Message	Description
Source: External	EXTERNAL TRIGGER INPUT pulse
Source: Manual	Front panel MANUAL button
Source: Disable	Disable all trigger sources
Source: IEEE TALK	IEEE-488 bus talk command
Source: IEEE GET	IEEE-488 bus GET command
Source: IEEE 'X'	IEEE-488 bus X command

Programming the Trigger Source

1. Press the SETUP button to enter the front panel trigger setup menu. Note that the instrument displays the following message:

TRIGGER SOURCE

2. Press ENTER, then use the ▲ or ▼ key to scroll through the available trigger sources, as summarized in Table 3-5.
3. When the desired trigger source is displayed, press ENTER to select it (or press ESC to leave the source unchanged and return to the previous trigger menu level).
4. Press ESC to return to normal display after choosing the trigger source.
5. Press MANUAL to trigger the unit.

3.6.3 Trigger Modes

Available Trigger Modes

There are two basic trigger modes:

Multiple: the instrument processes a multiple series of readings without requiring a trigger stimulus for each reading.

One-shot: a separate trigger is required for each reading to be processed.

Selecting the Trigger Mode

You can select the one-shot or multiple trigger mode as follows:

1. Press **SETUP**, then press ▼ to display the following message:

TRIGGER MODE

2. Press **ENTER**, then use ▲ or ▼ to select the desired trigger mode. For one-shot, the display will show:

Mode: One-Shot

With multiple, the display will show:

Mode: Multiple

3. Once you have selected the desired trigger mode, press **ENTER** to select it (or press **ESC** to cancel the selection and leave the mode unchanged).
4. Press **ESC** to return to normal display after selecting the trigger mode.
5. Press **MANUAL** to trigger the unit.

NOTES

1. The **MANUAL** indicator will be on to indicate that the instrument is waiting for a trigger when it is in the one-shot trigger mode.
2. When changing from one-shot to multiple, or when changing trigger sources, you must trigger the instrument with the appropriate trigger stimulus to start processing readings. The **MANUAL** indicator will flash to indicate that the instrument is waiting for a trigger. From the front panel, you can simply press the **MANUAL** key to trigger the instrument unless triggers are disabled.

3.6.4 Trigger Interval

When the instrument is in the multiple trigger mode, the programmed trigger interval determines the amount of time between readings. Note that the trigger interval does not affect readings in the one-shot trigger mode, but it does affect the buffer fill rate when in the multiple trigger mode. See paragraph 3.10 for details on using the buffer.

The allowable range for the trigger interval is 0.010sec (10msec) to 999.999sec with 1msec resolution. The default interval is 0.25sec.

Programming the Trigger Interval

Follow the steps below to set the trigger interval:

1. Press **SETUP** to enter the trigger menu selection process.
2. Use the ▲ or ▼ key to scroll through menu selections until the following is displayed:

TRIGGER INTERVAL

3. Press **ENTER**, and note that the following is displayed:

Interval: 000.250s

In this instance, the default rate of 0.25sec is displayed.

4. Using the numeric entry keys (0-9), key in the desired rate in the range of 000.010sec to 999.999sec (you can use ▲ or ▼ to move the cursor left or right).
5. Press **ENTER** to enter the rate you keyed in, or press **ESC** to cancel your entry and return to the **TRIGGER INTERVAL** menu.
6. Press **ESC** to return to normal display after setting the trigger interval.

NOTE

Attempting to program a trigger interval <10msec will result in the following error message: **Interval must be > = 10**

3.6.5 Trigger Delay

The trigger delay is the time period between the instant the unit receives a trigger and the time it begins processing a reading. The trigger delay can be used to allow a specific settling time before measurement.

The allowable range for the trigger delay is between 0sec (delay effectively disabled) and 999.999sec with 1msec resolution. The default trigger delay period is 0sec.

Programming the Trigger Delay

You can program the trigger delay as follows:

1. Press SETUP, then press ▲ to scroll to the following display:

TRIGGER DELAY

2. Press ENTER, and note the following display:

Delay: 000.000s

In this case, the default delay of 0sec is displayed.

3. Key in the desired delay period in the range of 000.000sec to 999.999sec, then press ENTER (or press ESC to cancel the selection and leave the delay unchanged). You can use ▲ or ▼ to move the cursor left or right.
4. Press ESC to return to normal display after programming the trigger delay.

3.6.6 Front Panel Triggering

When the instrument is on the one-shot trigger mode, you can trigger each reading by pressing the MANUAL key (when the instrument is in one-shot, the MANUAL indicator will be on continuously to indicate it is waiting for a trigger). The TRG annunciator will turn on to indicate that the instrument has been triggered, and it will go out when the reading is displayed.

The MANUAL key can also be used to trigger the instrument after changing from the one-shot trigger mode to the multiple trigger mode (MANUAL will flash to indicate that a trigger is required in the multiple trigger mode). Simply press MANUAL to initiate the multiple reading process.

3.6.7 External Triggering

The Model 182 has BNC connectors on the rear panel associated with external triggering. The EXTERNAL TRIGGER INPUT jack allows the Model 182 to be triggered by other instruments, and the METER COMPLETE OUTPUT jack allows the Model 182 to trigger other instruments.

External Trigger Input

The EXTERNAL TRIGGER INPUT jack requires a falling-edge, TTL-compatible pulse with the specifications shown in Figure 3-3.

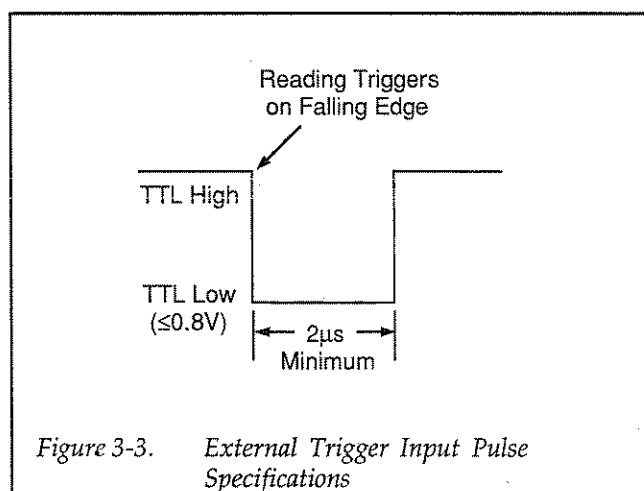

In order to externally trigger the Model 182, you must first select the rear panel trigger source, as discussed in paragraph 3.6.3. Place the instrument in the one-shot mode by using the TRIGGER MODE selection in the TRIG SETUP menu. The instrument will then process one reading per trigger pulse.

NOTE

If trigger pulses are applied more rapidly than the instrument can process readings, a TRIGGER OVERRUN error will occur. Refer to paragraph 3.6.9.

Meter Complete Output

The Model 182 provides a TTL-compatible output pulse that can be used to trigger other instrumentation. This pulse is provided via the METER COMPLETE OUTPUT jack on the rear panel and has the specifications shown in

Figure 3-4. This pulse appears at the output as each reading is being processed.

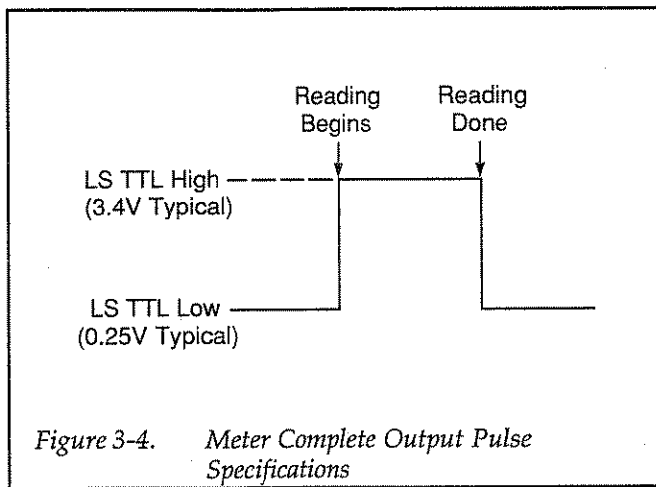

Figure 3-4. Meter Complete Output Pulse Specifications

Trigger Connections

Connections to both the EXTERNAL TRIGGER INPUT and METER COMPLETE output should be made with standard BNC connectors. Use only shielded cable to avoid the possibility of EMI radiation.

NOTE

The shells of both the EXTERNAL TRIGGER INPUT and METER COMPLETE OUTPUT jacks are connected to chassis ground and cannot be floated.

3.6.8 IEEE-488 Bus Triggering

There are three IEEE-488 bus commands which can be used to trigger the Model 182 over the IEEE-488 bus: GET, talk, and X. Details on programming the trigger sources and trigger modes over the bus and triggering the unit using bus commands are located in paragraph 4.2.19, Section 4.

3.6.9 Trigger Overrun Condition

In the one-shot trigger mode only, a trigger overrun condition will occur if the instrument is triggered while still processing a reading from a previous trigger. When this condition occurs, the Model 182 will display the front panel TRIGGER OVERRUN error message. Note that a

trigger overrun stimulus will not abort the reading currently being process.

3.7 FILTER

The FILTER key enables or disables the combination of analog and digital filter configurations selected with the FILTER menu. The following paragraphs discuss controlling the two filters and give details on filter operation and characteristics.

3.7.1 Enabling/Disabling the Filters

The front panel FILTER controls the state of both the analog and digital filters simultaneously. With FILTER off, both analog and digital filters are completely disabled regardless of other menu settings. With FILTER on, the analog filter state and digital filter response depend on the selections chosen in the FILTER menu. See paragraph 3.7.2 for information on digital filter response; paragraph 3.7.4 covers selection of the analog filter state.

NOTE

Selecting FILTER on with both analog and digital filters off their respective menus will automatically bring up the digital filter selection menu discussed below.

3.7.2 Setting the Digital Filter Response

The digital filter response menu selection determines the response of the filter when FILTER is enabled. You can program the digital filter response as follows:

1. Press MENU to enter the menu selection process. Note that the following message is displayed:

FILTER

2. Press ENTER to display the following message:

Digital Filter

3. Press ENTER, then use ▲ or ▼ to scroll through the desired digital filter response mode summarized in Table 3-6.
4. Once the desired filter response is displayed, press ENTER to select it (or press ESC to cancel the selection and leave the filter response unchanged).
5. Press ESC twice to return to normal display.

Table 3-6. Digital Filter Response

Filter Response	Description*
Filter Resp: Off	Digital filter off
Filter Resp: Fast	Minimal digital filtering, fastest filtered rate
Filter Resp: Medium	Moderate digital filtering, medium filtered rate
Filter Resp: Slow	Maximum digital filtering

* Indicates digital filter response with front panel FILTER on.

3.7.3 Digital Filter Characteristics

Filter Window

The fast and medium filter response levels use a window to control filter threshold (see Table 3-7). As long as the input signal remains within the defined window, the filter continues to process raw A/D conversions and (in the multiple trigger mode) update the display and IEEE-488 bus with processed, filtered readings.

If the signal changes to a value outside the window, the filter resets, and the filter starts processing again starting with a new initial conversion value from the A/D converter. This feature ensures rapid display update with large changes in input signal (the filter can then be reset by toggling the filter off then on). The slow response filter

uses no window, and will continuously filter the signal regardless of range or input signal changes. For that reason, the slow response filter will take the longest to settle to its final value, even with relatively small changes in input signal.

Table 3-7. Filter Window Summary

Range	Fast		Medium	
	3msec	Line Cycle, 100msec	3msec	Line Cycle, 100msec
3mV	±1.5µV	±150nV	±2.5µV	±250nV
30mV	±15µV	±400nV	±25µV	±600nV
300mV	±150µV	±4µV	±250µV	±6µV
3V	±1.5mV	±40µV	±2.5mV	±60µV
30V	±15mV	±400µV	±25mV	±600µV

Multiple Trigger Mode Filter Settling

If the instrument is in the multiple trigger mode, conversions will update the display, IEEE-488 output, and data store buffer (if enabled) while the filter is still processing. How fast the filter updates depends on several factors, including integration time, programmed trigger interval, as well as whether or not the analog filter is enabled. Table 3-8 summarizes the typical number of A/D conversions required for the filter to settle to the instrument noise floor for fast, medium, and slow filters at the various integration rates. Values for step changes between 10% and 100% of range are given in the table.

Table 3-8. Typical Number of Conversions Required for Digital Filter to Settle to within the Instrument Noise Floor

Step Change*	FAST			MEDIUM			SLOW	
	3msec	Line Cycle, 100msec		3msec	Line Cycle, 100msec		3msec	Line Cycle, 100msec
		3mV	30mV-30V		3mV	30mV-30V		
10%	8	30	21	19	93	43	87	301
25%	8	30	21	19	93	43	95	323
50%	8	30	21	19	93	43	101	339
75%	8	30	21	19	93	43	105	348
100%	8	30	21	19	93	43	107	355

*Step change as percent of range.

One-shot Trigger Mode Filter Settling

When the instrument is in the one-shot trigger mode, the display and IEEE-488 output are not updated until the filter has settled. As a result, each reading will not be made available until the filter has settled completely. To avoid unduly long processing times, the settling times for the digital filter are limited to a specific number of A/D Conversions, as summarized in Table 3-9.

Table 3-9. Filter One-shot Settling Count

Filter	Number of Conversions	
	3msec Integration	Line Cycle, 100msec Integration
Off	1	1
Fast	8	30 (3mV range) 21 (All other ranges)
Medium	19	93 (3mV range) 43 (All other ranges)
Slow	113	370 (All ranges)

3.7.4 Analog Filter Control

When enabled, the analog filter increases the normal-mode noise rejection ratio of the instrument by 35dB at 60Hz and is used on all ranges except the 30V range. The analog filter should be enabled for rated noise performance; note, however, that the relatively long settling times with the analog filter enabled make high reading rates impractical (the maximum usable reading rate with the analog filter enabled is approximately four readings per second regardless of the programmed trigger interval). For faster reading rates, you can disable the analog filter at the expense of somewhat increased reading noise.

You can control whether or not the analog filter is enabled when FILTER is turned on as follows:

1. From normal display, press the MENU key. The instrument will display the following message:

FILTER

2. Press ENTER, then use ▲ or ▼ to select the following display:

Analog Filter

3. Press ENTER, then use ▲ or ▼ to select the desired filter state (on or off), as follows:

Analog Filter: Off
Analog Filter: On

If you select off, the analog filter will always be off regardless of the FILTER state. If you select on, the analog filter can be turned on and off with the FILTER key.

4. Press ENTER to select the displayed state (or press ESC to cancel the selection and leave the filter state unchanged).
5. Press ESC twice to return to normal display.

3.8 READING RELATIVE

REL READING can be used to null offsets or to store a baseline value that will then be subtracted from subsequent readings. The following paragraphs discuss controlling the relative function and give step-by-step procedures for nulling offsets, storing baseline values, and directly programming the reading relative value.

The analog output relative function is discussed separately in paragraph 3.9.3.

3.8.1 Controlling Relative

To enable the reading relative feature, simply press the front panel REL READING key; the REL annunciator will turn on to indicate the present state of relative. The current reading becomes the baseline, if available. Otherwise, the next conversion after relative is enabled will become the baseline. If the instrument is in the multiple trigger mode, it will automatically store the baseline value.

To disable relative, press REL READING a second time.

NOTES

1. The REL READING LED will flash when relative is first enabled until the baseline value is stored, then it will turn on continuously once the baseline has been acquired.
2. During buffer recall, the REL READING LED does not reflect the status of relative while data was being stored in the buffer. See paragraph 3.10 for details on using the buffer.

3.8.2 Storing Baseline Values

Use the general procedure below to store a baseline value.

1. Turn on instrument power, and allow the Model 182 to warm up for at least one hour for rated accuracy.
2. Select a manual range high enough to handle both the baseline value and any subsequent measured voltages, or select auto-ranging if desired.
3. Select other operating modes such as filter and trigger modes as required.
4. Disable reading relative if it is presently enabled.
5. Connect the voltage to be used as the baseline value to the INPUT terminals.
6. Allow the reading to settle completely, then press the REL READING key.
7. If the instrument is in the one-shot trigger mode, press MANUAL to store the baseline value if there is no current valid reading. If you are using external triggering, you can also store the reading by triggering the instrument from the rear panel.
8. Disconnect the baseline voltage from the INPUT terminals, and connect the voltage to be measured in its place.
9. If the one-shot trigger mode is selected, press MANUAL (or apply an external trigger pulse) to display a reading, which will be the difference between the applied voltage and the baseline value. For example, with a 2V stored baseline and a 3V measured signal, the instrument will display 1V with relative enabled.
4. Allow the reading to settle completely, then press the REL READING key.
5. If the one-shot trigger mode is selected, press MANUAL to complete the process (or apply a trigger pulse if external triggering is being used).
6. Select a suitable manual range for the expected measured signal, or choose auto-ranging if desired.
7. Disconnect the test lead ends from one another, then connect the test leads to the voltage to be measured.
8. If one-shot trigger is being used, press MANUAL (or apply a trigger pulse) to trigger each subsequent reading.
9. The corrected reading can then be taken directly from the display.
10. Repeat steps 2 through 9 often to minimize the effects of thermal or instrument drift.

3.8.3 Nulling Offsets

Relative can also be used to null any residual offsets such as instrument offsets or thermal EMFs that might reduce measurement accuracy. Nulling offsets is particularly important when making measurements in the μV range or lower, and it is required to obtain rated accuracy when using the 3mV and 30mV ranges.

Proceed as follows to null offsets:

1. Turn on instrument power and allow the unit to warm up for at least one hour for rated accuracy and for minimum drift after nulling.
2. Disconnect the test leads from the voltage source, and short the test lead ends together.
3. Disable reading relative, and select the 3mV range. Select other operating modes such as filter as desired.

3.8.4 Programming the Relative Value

Instead of using an input signal to obtain the relative value, you can also program the desired relative value directly. The allowable range for the relative value is between $\pm 1\text{nV}$ and $\pm 30.3\text{V}$ with 1nV resolution. The default value is 0V.

Program the reading relative value as follows:

1. Press the MENU key, then use \blacktriangle or \blacktriangledown to scroll to the following message:

READING REL

2. Press ENTER and note the instrument displays the present relative value, whether that value was obtained with REL READING, or by programming it directly. For example, with a relative value of 0V, the unit will display:

Rel: +00.000000000V

3. Key in the desired relative value in the range of $\pm 1\text{nV}$ to $\pm 30.3\text{V}$, then press ENTER (or press ESC to cancel the new value and retain the original value).
4. Press ESC twice to return to normal display. The REL READING LED will turn on to indicate that relative is enabled, and displayed readings will be the difference between the applied signal and the stored baseline value.

NOTE

Programming a relative value $> 30.3\text{V}$ will result in the following error message:

Value must be $\leq 30.3\text{V}$.

3.8.5 Relative Considerations

Relative Over-ranging

Using reading relative does not increase the maximum voltage that can be measured on a given range because of A/D converter signal input limitations.

Relative Scaling

A stored relative baseline value is automatically scaled when the range is changed so that the baseline maintains a constant value. For example, if 2V is stored as a baseline value when the instrument is on the 3V range, the baseline will still have a value of 2V on the 30V range. Note, however, that selecting a range lower than the stored baseline will result in a displayed reading greater than the range indicated. In the current example, if 2V is the stored baseline, selecting the 300mV or lower range will result in a displayed reading of $-2.0V$.

3.9 ANALOG OUTPUT

The analog output of the Model 182 can be used for monitoring the input signal with an external device such as a chart or strip recorder. The analog output signal is generated by a 14-bit digital-to-analog converter from digital data supplied by the instrument's main microprocessor.

Programmable gain and output relative functions allow you to tailor the output to your particular monitoring instrument.

3.9.1 Analog Output Connections

The ANALOG OUTPUT jack, which is located on the rear panel, is a standard BNC connector. The center conductor is HI, and the outer ring or common is connected to chassis ground. Connections to the ANALOG OUTPUT jack should be made using coaxial cable to minimize the possibility of interference. Figure 3-5 shows typical analog output connections.

Note that the output resistance of the analog output is $1k\Omega$. To keep loading errors below 1%, the input resistance of the instrument connected to the analog output should be greater than $100k\Omega$. Maximum analog output current is 5mA.

3.9.2 Analog Output Configuration

The analog output can be configured either for normal use, or for source operation for testing. You can select the mode of operation as follows:

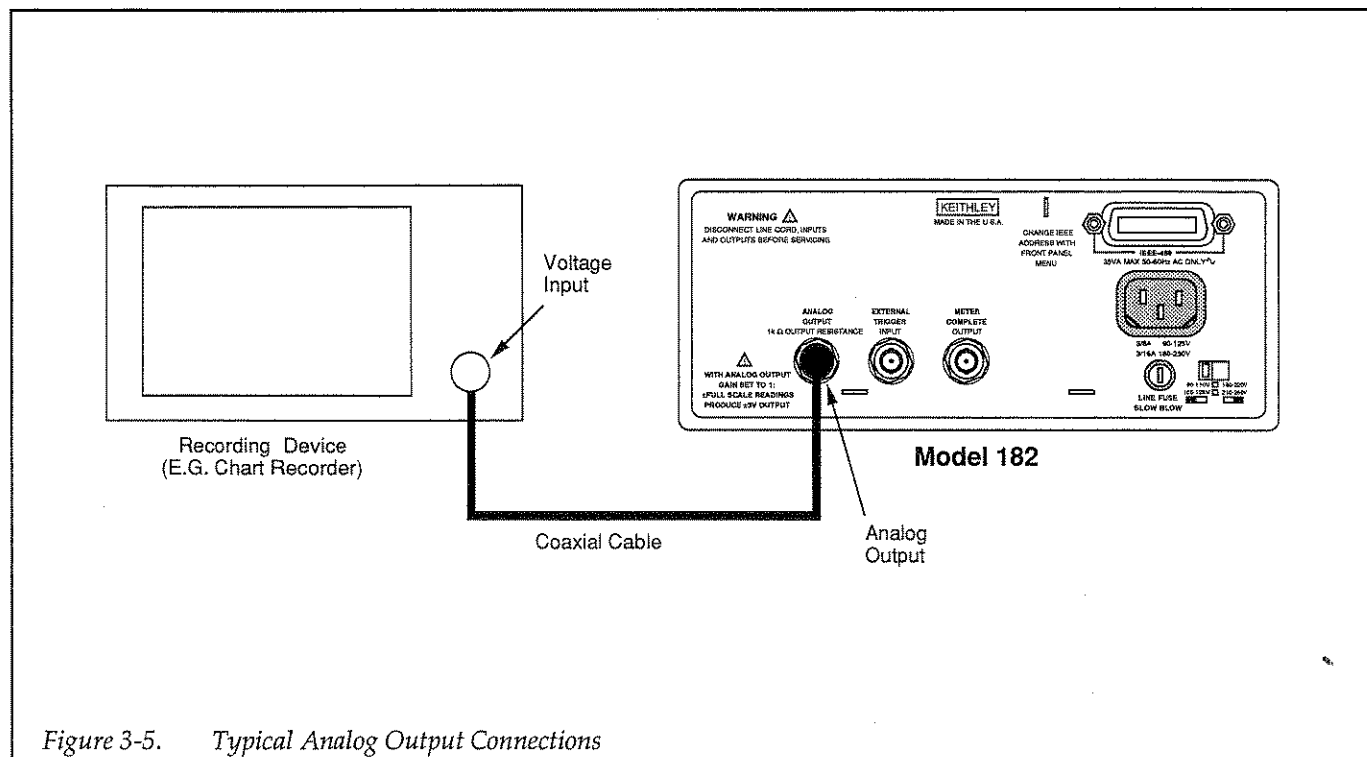

Figure 3-5. Typical Analog Output Connections

1. Press the MENU key then use ▲ to display the following:

CALIBRATE

2. Press ENTER, then use ▲ or ▼ to display the following:

Configure Output

3. Press ENTER, then use ▲ or ▼ to select the desired analog output operation mode:

Output: Normal

or,

Output: Source

If you wish to use the analog output normally, select Normal (see paragraphs 3.9.3 to 3.9.6 for operating details). If, on the other hand, you intend to use the analog output as a voltage source, select Source.

4. Once the desired configuration is displayed, press ENTER (or press ESC to cancel a change and return to the previous selection).
5. If you selected source, key in the desired value, then press ENTER.
6. Press ESC twice to return to normal display.

3.9.3 Analog Output Scaling

The analog output provides a nominal 0 to $\pm 3V$ maximum output voltage that follows the input signal. With X1 gain, a full range input provides a 3V output signal. For example, on the 30mV range, an input voltage of 30mV will result in a 3V output voltage. The absolute maximum output voltage is $\pm 3.3V$.

With higher gain factors, the amount of input signal required for a full scale analog output is reduced accordingly. For example, with X10 gain, an input signal of only 300mV is required on the 3V range for the nominal 3V analog output value.

See paragraph 3.9.4 below for information on programming gain values.

When an input overflow conditions occurs, the analog output will assume its full-scale value: +3.3V for positive inputs, and -3.3V for negative inputs. Similarly, the out-

put voltage will assume its $\pm 3.3V$ maximum if the gain is set too high for a given input voltage.

3.9.4 Programming Analog Output Gain

Analog output gain can be programmed to tailor the analog output levels to your particular monitoring device. The gain can be programmed to values between X0.001 and X999,999.999 with .001 resolution.

Program the analog output gain as follows:

1. Press MENU to enter the main menu selection process.
2. Press ▲ or ▼ to scroll to the following display:

OUTPUT

3. Press ENTER, and note that the following prompt is displayed:

Gain

4. Press ENTER and note the following prompt to input the gain factor:

Gain: +000001.000

In this example, the default gain factor of unity is displayed.

5. Key in the desired gain value in the range of 0.001 to 999,999.999 using the numeric entry keys (0-9), then press ENTER (or press ESC to cancel the process and leave the gain unchanged). You can use ▲ or ▼ to move the cursor left or right.
6. Press ESC twice to return to normal display.

NOTE

Programming a gain of 0 will result in the following message: **Value must be > 0.0**

3.9.5 Analog Output Relative

The REL OUTPUT control provides a convenient method to null a given offset, or to use an applied signal as a baseline value. The output voltage that appears at the ANALOG OUTPUT jack with REL OUTPUT enabled is computed as follows:

$$V_{OUT} = G_{INTERNAL} G_{USER} (V_{IN} - V_{REL})$$

Where: V_{OUT} = analog output voltage
 V_{IN} = signal voltage applied to INPUT jack
 V_{REL} = stored analog output relative value
 G_{USER} = gain factor set with GAIN menu
 $G_{INTERNAL}$ = Internal gain factor, as follows:

Range	$G_{INTERNAL}$
30V	0.1
3V	1
300mV	10
30mV	100
3mV	1000

As an example, assume that you had previously stored +100mV as an analog output relative value, and that an input signal of 300mV is applied to the input with the instrument on the 300mV range. With an analog output gain of 1, the analog output voltage would be:

$$V_{OUT} = 10 \times 1 (0.3 \cdot 0.1)$$

$$V_{OUT} = 2V$$

Storing the Relative Value

The basic procedure for using REL OUTPUT is as follows:

1. Setup the measurement range of the Model 182 as appropriate, and connect the signal voltage to be used as a null or offset value.
2. Press REL OUTPUT to store the analog output relative value.
3. If the instrument is in the one-shot trigger mode, and no reading is available, press MANUAL to store the analog output relative baseline value.
4. Connect the signal to be measured to the INPUT. The analog output voltage will be determined both by the stored relative value and the gain, as described above.
5. To disable the analog output relative function, press REL OUTPUT a second time.

3.9.6 Programming the Analog Output Relative Value

In addition to using an input signal as a relative value, you can also program that relative value directly. The al-

lowable range for the programmed relative value is between $\pm 1nV$ and $\pm 30.3V$ with 1nV resolution.

You can program the analog output relative value as follows:

1. Press MENU to enter the main menu.
2. Use \blacktriangle or \blacktriangledown to scroll to the following display:

OUTPUT

3. Press ENTER, then use \blacktriangle or \blacktriangledown to select the following:

Rel

4. Press ENTER and note the instrument displays the present relative value, whether that value was obtained with REL OUTPUT, or by programming it directly. For example, with a relative value of 0V, the unit will display:

Rel: +00.00000000

5. Key in the desired value, then press ENTER to complete the entry process (or press ESC to cancel the new value and retain the previous analog output value). Use \blacktriangle or \blacktriangledown to move the cursor left or right.
6. Press ESC twice to return to normal display.
7. The OUTPUT REL indicator will turn on to indicate that relative is enabled, and the analog output signal will reflect both the stored baseline and the gain as described in paragraph 3.9.5.

NOTE

Programming a relative value $> 30.3V$ will result in the following error message:

Value must be $\geq 30.3V$

3.10 BUFFER OPERATION

The Model 182 buffer can be used to store up to 1024 readings for later recall. Recalled data includes buffer location and time stamp as well as the following statistical functions: sample size, minimum, maximum, average, and standard deviation. The following paragraphs discuss programming the buffer for data storage, multiple and one-shot data storage, as well as recalling time, location data, and buffer statistics from the front panel.

3.10.1 Buffer Control Keys

The following keys control buffer operation:

STORE	Enters buffer store menu and cancels data storage.
RECALL	Enters buffer recall mode.
▲ or ▼	Scrolls through STORE or RECALL menu selections and buffer locations when in recall mode, and also moves cursor left or right.
ENTER	Selects displayed buffer menu item, moves to next menu.
ESC	Cancels displayed buffer menu item, moves to previous menu.
0-9 keys	Enter numeric data for buffer size and location.

3.10.2 Multiple Trigger Mode Data Storage

For multiple trigger mode data storage, the instrument must be in the multiple trigger mode. The interval between stored readings is determined by the programmed trigger interval, as outlined in the steps below.

1. If necessary, use the TRIGGER MODE selection in the SETUP menu to place the instrument in the multiple trigger mode.
2. The trigger interval determines the amount of time between stored readings. You can program the desired trigger interval as follows:
 - A. Press SETUP.
 - B. Use ▲ or ▼ to scroll through to the following message:

TRIGGER INTERVAL

- C. Press ENTER, then use the numeric keys to enter the desired interval (0.010sec-999.999sec) at the following prompt:

Interval: 000.250s

- D. Press ENTER to program the entered value (or press ESC) to cancel the entry and return to the previous value).
 - E. Press ESC to return to normal display.
3. Press the STORE key to enter the data storage mode. The instrument will prompt you to enter the number of readings to store:

Store size – 0000

The store size value determines how many readings will be stored (up to a maximum of 1024) before the storage cycle stops. However, a store size of 0000 is a special case that indicates continuous storage. After 1024 readings are stored, new readings will be stored beginning at the first memory location, overwriting old data.

4. Key in the desired number of readings to store (use 0000 for multiple, wrap-around storage).
5. Press ENTER to program the value and begin storage immediately (or press ESC to cancel the entry and return to normal display mode). The STORE indicator will flash to indicate that data is presently being stored at the programmed interval.
6. After all programmed readings have been stored, the STORE indicator will stop blinking and stay on continuously. In continuous, of course, STORE will blink continuously since the storage process never stops.

NOTES

1. Data can be recalled during the storage process; see paragraphs 3.10.4 and 3.10.5.
2. Once the buffer is enabled, storage can be halted at any time by pressing the STORE key. Data stored in the buffer up to that point will remain available for recall until the storage process is initialized again.
3. Enabling data storage clears the buffer of any previously-stored readings.
4. Range, resolution, filter, relative, and trigger parameters can all be changed during data storage. If one of these parameters is changed during a conversion, the present reading will be aborted, and a new conversion will be triggered. The aborted reading will not be stored in the current buffer location.
5. Only range and resolution are stored with each reading; other instrument states are not stored in the buffer.
6. The error message below will be displayed on the status line if you attempt to program more than 1024 readings:

Size must be < 1025

3.10.3 One-shot Trigger Mode Data Storage

With one-shot trigger mode data storage, readings are stored at a rate determined by input triggers, with one reading per trigger stored in the data buffer. With front-panel operation, you can trigger these readings either with the MANUAL key, or by applying an appropriate

trigger pulse to the EXTERNAL TRIGGER INPUT jack (if external triggering is enabled).

1. Select the one-shot trigger mode using the TRIGGER MODE selection in the SETUP menu.
2. If desired, program the trigger delay period. The trigger delay is the time period between each trigger and the subsequent reading acquisition (and buffer storage if the buffer is enabled). You can program the desired trigger delay as follows:
 - A. Press SETUP.
 - B. Use ▲ or ▼ to scroll through to the following message:

TRIGGER DELAY

- C. Press ENTER, then use the numeric keys to enter the desired rate (000.000sec-999.999sec) at the following prompt:

Delay: 000.000s

- D. Press ENTER to program the entered value (or press ESC) to cancel the entry and return to the previous value).
- E. Press ESC to return to normal display.
3. Press the STORE key to enter the store buffer mode. The instrument will prompt you to enter the store size:

Store size - 0000

4. Key in the desired number of readings to store (1-1024), or select a value of 0000 to choose continuous storage.
5. Press ENTER to program the store size and return to normal display (or press ESC to cancel the size value and leave it unchanged).
6. Press the MANUAL key to store each reading. Remember that one trigger per reading is required when the unit is in the one-shot trigger mode. While data storage is enabled, the STORE indicator will flash. When the buffer is full, STORE will stay on continuously (except in the continuous buffer mode).

NOTES

1. Data can be recalled during the storage process; see paragraph 3.10.4 and 3.10.5.
2. Once the buffer is enabled, storage can be halted at any time by pressing the STORE key. Data stored in

the buffer up to that point will remain available for recall until the storage process is started again.

3. Enabling data storage clears the buffer of previously-stored readings.
4. Range, resolution, filter, relative, and trigger parameters can all be changed during data storage. If one of these parameters is changed during a conversion, the present reading will be aborted, and a new conversion will be triggered. The aborted reading will not be stored in the current buffer location.
5. Only range and resolution are stored with each reading; other instrument states are not stored in the buffer.
6. A TRIGGER OVERRUN error message will be displayed if the unit is triggered while processing a reading. The current reading will not be aborted.
7. The error message below will be displayed on the status line if you attempt to program more than 1024 readings:

Size Must Be < 1025

8. When data is being recalled, the REL READING LED does not indicate whether or not relative was enabled when data was stored.

3.10.4 Recalling Reading, Location, and Time Stamp Data

Reading, location, and time stamp information can be recalled during or after the data storage process. Figure 3-6 shows the menu tree structure for RECALL.

Procedure:

1. Press RECALL to enter the recall mode. The unit will display the following message:

Recall:Loc and Time

2. Press ENTER to display data at the last stored buffer location. A Typical example is:

#0877: -05.47773mV
Time = 000007.250s

Note that the reading line includes the buffer location on the left, while the reading itself is on the right. The time stamp, which represents the total elapsed time since the start of data storage, appears on the status line.

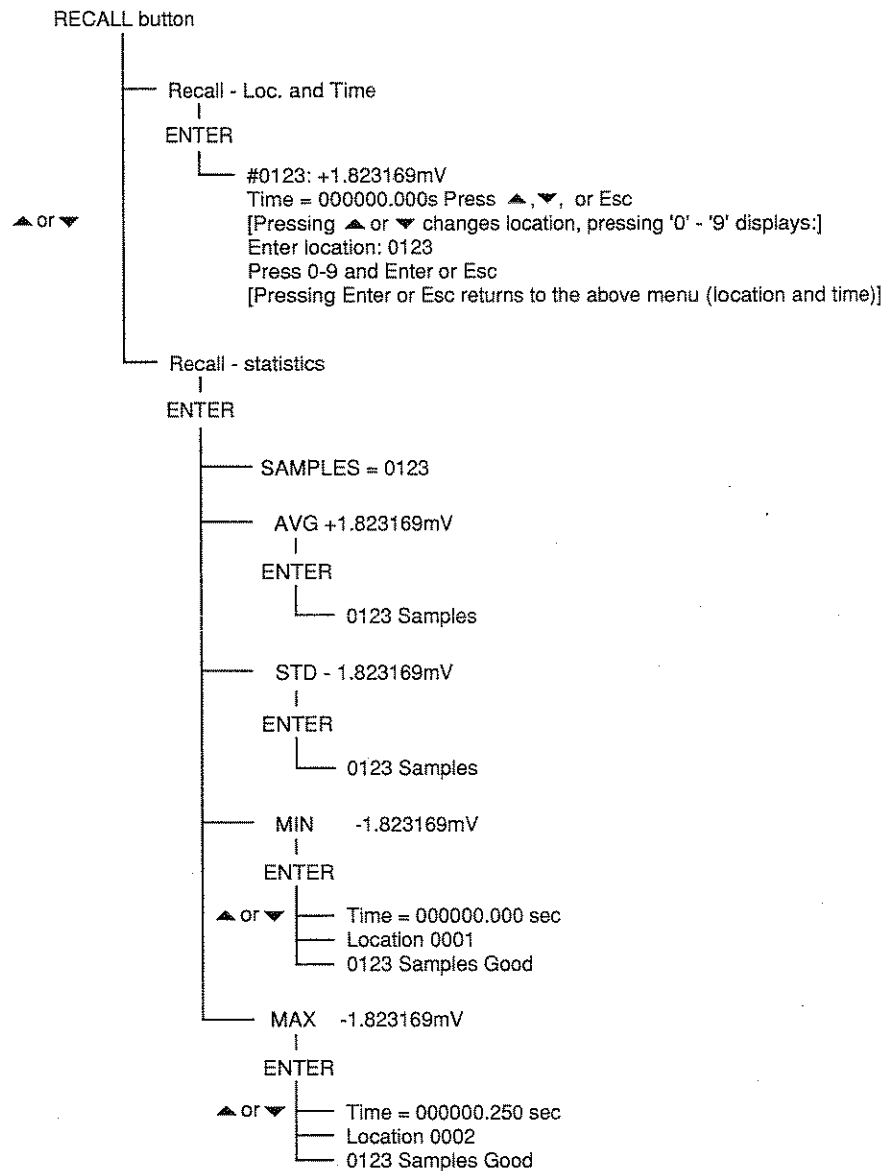

Figure 3-6. RECALL Menu Tree

- To sequentially scroll through buffer locations, use the ▲ or ▼ key. Pressing ▲ increments buffer locations, and pressing ▼ decrements buffer locations.
- To randomly access a specific buffer location, press a number key to bring up the following prompt:
Enter location: 0100
- Key in the desired location number (1 to 1024). After keying in all the digits, press ENTER to access that location (or press ESC to cancel the entry). You can then continue to scroll through locations using ▲ or ▼.
- Press ESC twice to exit the recall mode and return to normal display.

NOTES

1. The following message will be displayed if you attempt to recall data at an empty buffer location:

NO VAL YET

2. The unit will continue to store data while recalling data until the buffer is full, or continuously in the wrap-around storage mode.
3. Recalled readings reflect the front panel range and resolution display format at the time the data was stored. For example, if data at a particular location was stored with the instrument on the 30mV range at 4 1/2-digit resolution, the recalled data will be displayed with the same 30mV range, 4 1/2-digit display format.
4. The range of displayed time stamp values is between 0.001sec and 999999.999sec.
5. The time stamp value is reset to zero each time data storage is enabled. The time starts when the first trigger is received, and the time stamp value corresponds to the start of the conversion process when the unit is on the proper range.
6. During recall, the REL READING LED will not indicate whether or not relative was enabled while data was being stored.
7. The usual OVERFLOW message will be displayed for any recalled overflow readings.
8. When randomly recalling buffer locations, an error message will be displayed if you select a location <1 or >1024.

3.10.5 Recalling Buffer Statistics

Available Statistics

In addition to location, reading, and time stamp information, recall also gives you access to the following buffer statistics:

- Samples (number of readings stored).
- Maximum (most positive) reading in the buffer. Additional information includes the time stamp and location for the maximum buffer value, as well as the number of valid readings in the buffer.
- Minimum (most negative) reading in the buffer. In addition, you can display the time stamp and location number for the minimum buffer value, and the number of valid readings.
- Standard deviation of all readings stored in the buffer. Also, you can display the number of samples and valid readings.

- Average of all readings stored in the buffer. The average display also allows you to display the number of samples and valid readings.

Procedure:

1. From normal display; press RECALL. The instrument will display the following message:

Recall:Loc and Time

2. Press the ▲ or ▼ key to display the following message:

Recall:Statistics

3. Press ENTER, and note that the instrument displays the stored number of samples, for example:

SAMPLES = 0100

4. Press ▲ and note that the maximum value is displayed, as in this example:

MAX 182.345mV

5. Press ENTER then use the ▲ or ▼ key to display the time and location of the maximum value, as well as the number of good (non-overflowed) readings stored in the buffer. Typical examples are:

**Time = 000001.00sec
Location 0011
0042 Samples Good**

6. Press ESC to return to the maximum buffer reading display.
7. Press ▲ to advance to the minimum value display; a typical example might be:

MIN -3.1234V

8. Press ENTER then use ▲ or ▼ to display the time and buffer location number of the minimum value, and the number of good (non-overflowed) readings. Examples include:

**Time=000012.13sec
Location 0857
All Samples Good**

9. Press ESC to return to the minimum buffer reading display.

10. Press **▲** again to display the standard deviation, as in this example:

STD 1.25067mV

11. Press ENTER to display the number of samples used for the standard deviation calculation, for example:

0052 Samples

If one or more of the samples is invalid, the unit will also display the number of valid samples, for example:

Press any key (0050 valid)

12. Press any key to return to the standard deviation value display.
13. Finally, press **▲** to display the average of all readings presently stored in the buffer:

AVG 23.4000V

14. Press ENTER to display the number of samples used for the average calculation. A typical example is:

0100 Samples

If one or more of the stored samples is invalid, the unit will also display the number of valid samples, for example:

Press any key (0086 valid)

15. Press any key, then press ESC twice to return to normal display.

NOTES

1. Statistics resolution is limited to the resolution of the lowest resolution reading in the buffer.
2. Statistics can be displayed while the buffer is storing data, but the statistical calculations will be based only on data stored up to the time you enter a particular statistics display.
3. Attempting to display statistics information with no data in the buffer will result in the following error message:

NO VAL YET

4. Any overflowed readings stored in the buffer will not be used in the statistics calculations. The number of good (valid) readings for each statistics function can be displayed as outlined above.

3.11 MENU

Table 3-10 summarizes the operating modes that are accessed with the MENU key along with the associated main menu display messages. While many of these features are covered elsewhere in this manual, all menu items are summarized here for convenient reference.

Table 3-10. MENU Summary

MENU Message	Description	Paragraph
FILTER	Set digital filter response, analog filter on/off	3.11.1
INTEGRATION TIME	Set A/D integration period (3msec, line cycle, or 100msec)	3.11.2
DISPLAY RESOLUTION	Set display resolution to 3 1/2, 4 1/2, 5 1/2, or 6 1/2 digits	3.11.3
READING REL	Program reading relative value	3.11.4
OUTPUT	Set analog output gain and relative value	3.11.5
SETUP	Save user setup, recall user or factory default setup	3.11.6
SET IEEE ADDRESS	Select IEEE-488 primary address (0-30)	3.11.7
CALIBRATE	Display test, calibrate Model 182, configure analog output for normal or source	3.11.8

Menu Control Keys

The keys summarized below will allow you to access and program the various menu items:

MENU Press the MENU key to enter the main menu sequence. Pressing MENU will display the first menu item in Table 3-10.

▲ or ▼ Use or to scroll through menu selections. The ▼ key scrolls down through the menu items, and the ▲ key scrolls up through menu items. ▲ and ▼ also move the cursor left or right respectively during numeric parameter entry.

0-9 These numeric entry keys are used to enter numeric parameters for some menu selections such as analog output gain and value.

± Once the MENU key has been pressed to enter the menu, the function of MENU changes to ±, which is used to toggle between positive and negative values where applicable.

ENTER Pressing ENTER accepts a menu selection or entry and moves down to the next lower menu level (where applicable).

ESC Pressing ESC cancels the current menu selection or parameter and returns to the previous menu level or exits the menu at the highest level.

Figure 3-7 shows the MENU tree structure and how the various controls interact.

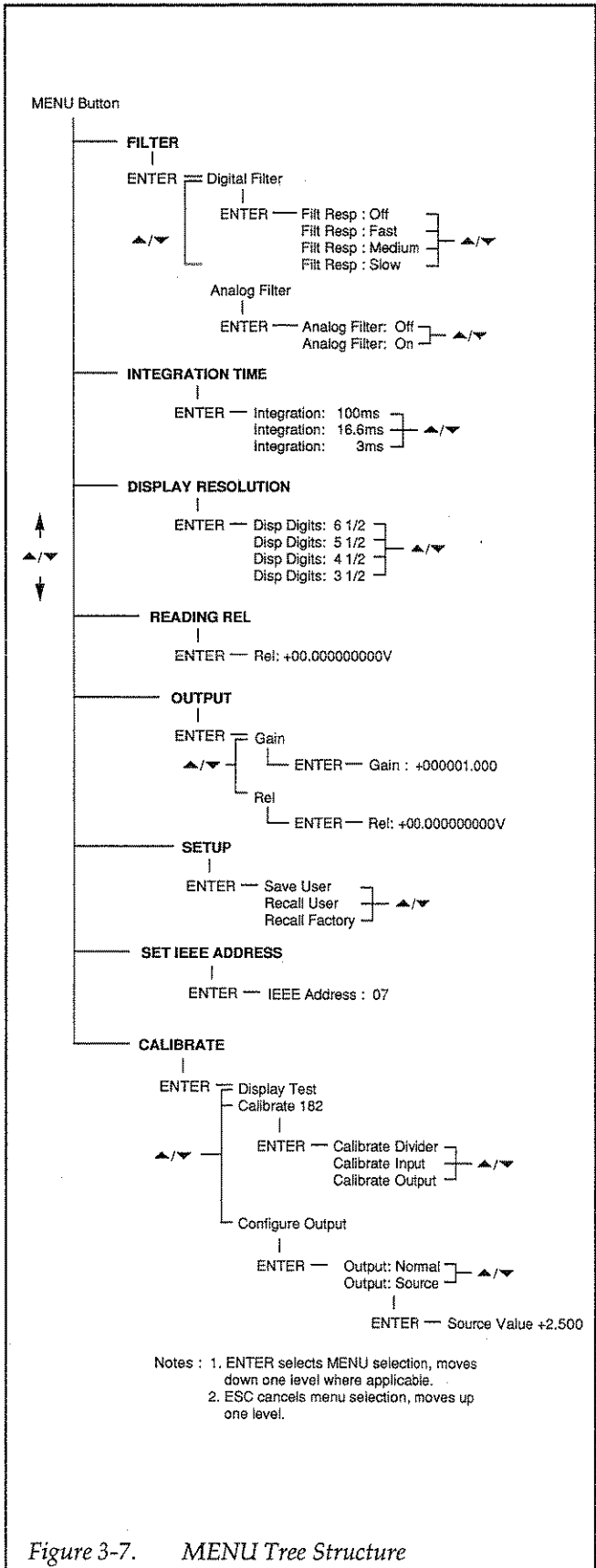

Figure 3-7. MENU Tree Structure

3.11.1 Filter

The FILTER selection allows you to set the digital filter response and to control on/off operation of the analog filter.

Digital Filter Response

The digital filter response selection allows you to control the amount of digital filtering applied to the input signal when the digital filter is enabled (FILTER on). You can set the digital filter response by following the steps outlined below. The digital filter is covered in detail in paragraph 3.7.

1. From normal display, press MENU to enter the menu selection process. The instrument will display the following message:

FILTER

2. Press ENTER to display the following message:

Digital Filter

3. Press ENTER, then use ▲ or ▼ to scroll through and select one of the filter response selections below:

Filt Resp: Off
Filt Resp: Fast
Filt Resp: Medium
Filt Resp: Slow

4. Once the desired filter response is displayed, press ENTER to select it (or press ESC to cancel the selection and leave the filter response unchanged).
5. Press ESC twice to return to normal display.

Analog Filter State

The analog filter selection allows you to control whether or not the analog filter is enabled with FILTER on. When enabled, the analog filter increases the NMRR of the instrument by 35dB at 60Hz. Note that the analog filter affects measurements on the 3mV–3V ranges; it is not used on the 30V range. You can enable or disable the analog filter as follows:

1. From normal display, press the MENU key. The instrument will display the following message:

FILTER

2. Press ENTER, then use ▲ or ▼ to select the following display:

Analog Filter

3. Press ENTER, then use ▲ or ▼ to select the desired filter state (on or off), as follows:

Analog Filter: Off
Analog Filter: On

Select on if you want the analog filter enabled with FILTER on, or select off if you want the analog filter off at all times.

4. Press ENTER to select the displayed state (or press ESC to cancel the selection and leave the filter state unchanged).
5. Press ESC twice to return to normal display.

3.11.2 Integration Time

The INTEGRATION TIME parameter sets the integration period of the A/D converter. The integration period affects the usable resolution, the amount of reading noise, as well as the ultimate reading rate of the instrument.

Table 3-11 summarizes the integration periods along with the usable resolution and relative reading rate and noise performance characteristics.

The optimum integration time setting for a given application will depend on your measurement requirements. If speed is of primary importance, use the 3msec integration period at the expense of increased reading noise and less usable resolution. For maximum common-mode and normal-mode noise rejection, use the 100msec integration period. Line cycle integration can be used when a compromise between noise performance and speed is acceptable.

You can program the integration period parameter as follows:

1. From normal display, press MENU.
2. Press ▼ to display the following message:

INTEGRATION TIME

Table 3-11. Integration Periods

Integration Period	Usable Resolution	Reading Rate	Noise
3msec	4 1/2 digits	Fastest	Maximum
Line cycle*	6 1/2 digits	Medium	Medium
100msec	6 1/2 digits	Slowest	Minimum

* 16.67msec @ 60Hz; 20msec @ 50Hz. Line frequency is automatically determined by instrument, and the line cycle integration rate is set accordingly.

- Press ENTER, then use ▲ or ▼ to select the desired integration rate:

Integration: 16.6ms
Integration: 3 ms
Integration: 100ms

NOTE

The unit will display 20ms instead of 16.6ms for line cycle integration period when the unit is powered from a 50Hz power line.

- Press ENTER to select the displayed rate (or press ESC to cancel the selection and leave the rate unchanged).
- Press ESC to return to normal display.

3.11.3 Display Resolution

The display can be set to operate with 3 1/2, 4 1/2, 5 1/2, or 6 1/2-digit resolution, as follows:

- From normal display, press MENU, then use the ▼ key to scroll the following message:

DISPLAY RESOLUTION

- Press ENTER, then use ▲ or ▼ to choose one of the following selections:

Disp Digits: 6 1/2
Disp Digits: 5 1/2
Disp Digits: 4 1/2
Disp Digits: 3 1/2

- Press ENTER once the desired resolution setting is displayed (or press ESC to cancel the selection and leave the resolution unchanged).
- Press ESC to return to normal display.

NOTES

- The selected display resolution affects the resolution of readings stored in the buffer. Buffer readings will have the same resolution as the selected display resolution at the time readings were stored. See paragraph 3.10 for buffer information.
- The programmed integration period can affect the usable display resolution. Usable resolution with the 3msec integration period is 4 1/2 digits.

3.11.4 READING REL

Instead of using an input signal to obtain a reading relative value, you can also directly program the desired relative value. The allowable range for the relative value is between ±1nV and ±30.3V with 1nV resolution. The default value is 0V. Paragraph 3.8 discusses reading relative in more detail.

Program the reading relative value as follows:

- Press the MENU key, then use ▼ to scroll to the following message:

READING REL

- Press ENTER and note the instrument displays the present relative value, whether that value was obtained with REL READING, or by programming it directly. For example, with a relative value of 0V, the unit will display:

Rel: +00.000000000V

3. Key in the desired relative value in the range of $\pm 1\text{nV}$ to $\pm 30.3\text{V}$, then press ENTER (or press ESC to cancel the new value and retain the original value).
4. Press ESC to return to normal display. The REL READING LED will turn on to indicate that relative is enabled, and subsequent readings will be the difference between the applied signal and the programmed relative value.
5. Key in the desired gain value in the range of 0.001 to 999,999.999 using the numeric entry keys (0–9), then press ENTER (or press ESC to cancel the process and leave the gain unchanged).
6. Press ESC twice to return to normal display.

NOTE

Programming a relative value $>30.3\text{V}$ will result in the following error message:

Value must be $\geq 30.3\text{V}$

3.11.5 Output

The OUTPUT menu selection allows you to program the analog output gain and the analog output relative value. For complete details on using the analog output, refer to paragraph 3.9.

Analog Output Gain

Analog output gain can be programmed to tailor the analog output levels to your particular monitoring device. The gain can be programmed to values between X0.001 and X999,999.999 with 0.001 resolution.

Program the analog output gain as follows:

1. Press MENU to enter the main menu selection process.
2. Press \blacktriangle or \blacktriangledown to scroll to the following display:

OUTPUT

3. Press ENTER and note that the following message is displayed:

Gain

4. Press ENTER and note the following prompt to input the gain factor:

Gain: +000001.000

In this example, the default gain factor of unity is displayed.

NOTE

Programming a gain of 0 will result in the following message:

Value must be >0.0

Analog Output Relative Value

In addition to using an input signal to obtain an analog output relative value, you can also program that relative value directly. The allowable range for the programmed relative value is between $\pm 1\text{nV}$ and $\pm 30.3\text{V}$ with 1nV resolution.

You can program the analog output relative value as follows:

1. Press MENU to enter the main menu.
2. Use \blacktriangle or \blacktriangledown to scroll to the following display:

OUTPUT

3. Press ENTER, then use \blacktriangle or \blacktriangledown to select the following:

Rel

4. Press ENTER and note the instrument displays the present relative value, whether that value was obtained with REL OUTPUT, or by programming it directly. For example, with a relative value of 0V, the unit will display:

Rel: +00.000000000

5. Key in the desired value, and press ENTER to complete the entry process (or press ESC to cancel the new value and retain the previous analog output value).
6. Press ESC twice to return to normal display.
7. The OUTPUT REL indicator will turn on to indicate that relative is enabled, and the analog output signal will depend on both the stored baseline and the gain as described in paragraph 3.9.5.

NOTE

Programming a relative value >30.3V will result in the following error message:

Value must be >= 30.3V

3.11.6 Setup

The SETUP option allows you to save the current instrument configuration as a user setup, and then recall that setup at a later time. You can also recall the factory default configuration using the recall setup option.

Save User Setup

The save user setup feature allows you to save the instrument operation conditions summarized in Table 3-12, which also lists factory default conditions for each operating state. The instrument will then assume the saved operating conditions at power-on, and you can recall the saved setup using the recall setup feature discussed below.

NOTE

Save setup does not save IEEE-488 parameters such as primary address, G-format, etc. Use the menu SET IEEE ADDRESS selection to set the primary address

Save a user setup as follows:

1. First select the operating conditions you wish to have saved, using Table 3-12 as a guide.
2. Press the MENU button to enter the menu.
3. Use the ▲ or ▼ key to scroll to the following display message:

SETUP

4. Press ENTER, and note that the instrument displays the following:

Save User

5. Press ENTER. The instrument will prompt you as to whether or not you wish to actually save the current setup:

**Are you sure?
ENTER = yes, ESC = no**

6. Press ENTER to save the setup (or press ESC to cancel the save procedure). During the save process, the instrument will display the following:

**Please wait...
Saving the present setup**

7. Press ESC to return to normal display.

Table 3-12. Save/Recall Setup Parameters

Description	Factory Default State
Range	30V, Auto-range off
Reading Relative	Off, value = 0
Analog filter	Off
Digital filter	On, medium response
Analog Output	Relative off, 0V, gain 1.0, output: normal, source value = 0V
Integration Period	Line cycle (16.67msec, 60Hz; 20msec, 50Hz)
Display Resolution	6 1/2 digits
Trigger mode	Multiple
Trigger source	External (MANUAL key also enabled)
Trigger interval	0.25sec
Trigger delay	0sec

Recalling a Setup

The two recall setup options allow you to recall either the user-saved setup (discussed above) or the factory default conditions. Table 3-12 summarizes conditions that are recalled and their factory defaults.

NOTE

Recall setup does not affect the programmed primary address.

Recall a setup as follows:

1. From normal display, press MENU.
2. Use ▲ or ▼ to scroll to the following display:

SETUP

3. Press ENTER, then use ▲ or ▼ to select the type of setup to be recalled:

Recall User Recall Factory

The factory selection restores factory-default conditions (Table 3-12), and the user selection restores the setup saved with the save setup feature discussed above.

4. Press ENTER to recall the selected type of setup (or press ESC to abort the recall process and leave your setup unchanged). During the recall process, the instrument will display the following:

Please wait...
Recalling the setup

5. Press ESC to return to normal display.

3.11.7 IEEE-488 Primary Address

The primary address of the Model 182 must be the same as the address you specify in the controller's programming language when using the Model 182 over the IEEE-488 address. The default primary address is 7, and the allowable range for the primary address is 0-30.

Program the primary address as follows:

1. From normal display, press the MENU key, then press ▲ twice, to display the following message:

SET IEEE ADDRESS

2. Press ENTER to display the programmed address:

IEEE Address: 07

In this example, the default primary address of 7 is displayed. At this point, you can press ESC twice to return to normal display without changing the primary address.

3. Key in the desired address using the numeric entry keys. Remember that the allowable range for the primary address is 0-30.
4. Once you have keyed in the desired address, press ENTER to complete the process (or press ESC to cancel the entry and leave the address unchanged).
5. Press ESC to return to normal display.

NOTES

1. The new primary address will automatically be saved as power-on default when programmed.
2. Attempting to program a primary address greater than 30 will result in the following error message:

Address must be < 31

3. Each device on the IEEE-488 bus must have a different primary address.
4. Recalling a user or factory setup does not change the primary address.

3.11.8 Calibrate

The CALIBRATE menu selection allows you to test the front panel display, perform instrument calibration, and to configure the analog output.

Display Test

The display test allows you to verify that each pixel and annunciator in the vacuum fluorescent display is working properly. You can perform the display test as follows:

1. From normal display, press MENU.
2. Use the ▲ key to scroll to the following message:

CALIBRATE

3. Press ENTER, and note that the instrument displays the following:

Display Test

4. Press ENTER to perform the test (or press ESC to cancel without performing the test).
5. Observe the display to make sure that all elements are working properly. Press ENTER to sequence through the various parts of the test, which includes all pixels on, digit sequencing, and a checkerboard pattern with alternate pixels on. You can also press ESC to go on to the next part of the test, if desired. After all test types, the unit will return to the Display Test prompt.
6. Press ESC twice from the Display Test prompt to return to normal display.

Calibrate 182

The Calibrate 182 selection gives access to the digital calibration features of the Model 182. The three calibration selections include:

Calibrate Divider
Calibrate Input
Calibrate Output

Calibration requires specialized test equipment and technical expertise and is covered in detail in paragraph 7.3 in Section 7.

NOTE

Do not access the calibration selections in the menu unless you are actually performing calibration. Improper selection of calibration parameters with the CAL switch in the unlocked position may cause improper calibration of the instrument.

Configure Output

The analog output can be configured either for normal use, or it can be used as a programmable voltage source

(analog output operation is covered in paragraph 3.9). You can select the mode of operation as follows:

1. Press the MENU key then use ▲ to display the following:

CALIBRATE

2. Press ENTER, then use ▲ or ▼ to display the following:

Configure Output

3. Press ENTER, then use ▲ or ▼ to select the desired analog output operation mode:

Output: Normal
or,
Output: Source

If you wish to use the analog output normally, select Normal. If, on the other hand, you intend to use the analog output as a programmable voltage source, select Source.

4. Once the desired configuration is displayed, press ENTER (or press ESC to cancel a change and return to the previous selection).
5. If you have selected source operation, you will be prompted to enter the source value:

Source Value: +0.000

6. Key in the desired source value (0 to $\pm 3.3V$), then press ENTER (or press ESC to cancel a new entry and retain the previous value).
7. Press ESC as necessary to return to normal display.

NOTE

Attempting to program source values $> \pm 3.3V$ will result in the following error message:

Valid values: $-3.3V$ to $+3.3V$

3.12 MEASUREMENT CONSIDERATIONS

Low-level voltage measurements made using the Model 182 can be adversely affected by various types of noise or other unwanted signals that can make it very difficult to obtain accurate voltage readings. Some of the phenomena that can cause unwanted noise include thermoelectric effects (thermocouple action), source resistance noise, magnetic fields, and radio frequency interference. The following paragraphs discuss the most important of these effects and ways to minimize them.

3.12.1 Thermoelectric Potentials

Thermoelectric potentials (thermal EMFs) are small electric potentials generated by differences in temperature at the junction of dissimilar metals. The following paragraphs discuss how such thermals are generated and ways to minimize their effects.

Thermoelectric Coefficients

As shown in Table 3-13, the magnitude of thermal EMFs generated depends on the particular materials involved. Best results are obtained with clean copper-to-copper connections as indicated in the table.

Table 3-13. Thermoelectric Coefficients

Material	Thermoelectric Potential
Copper-Copper	0.2 μ V/ $^{\circ}$ C
Copper-Silver	0.3 μ V/ $^{\circ}$ C
Copper-Gold	0.3 μ V/ $^{\circ}$ C
Copper-Cadmium/tin	0.3 μ V/ $^{\circ}$ C
Copper-Lead/tin	1-3 μ V/ $^{\circ}$ C
Copper-Kovar	40 μ V/ $^{\circ}$ C
Copper-Silicon	400 μ V/ $^{\circ}$ C
Copper-Copper Oxide	1000 μ V/ $^{\circ}$ C

Thermoelectric Generation

Figure 3-8 shows a representation of how thermal EMFs are generated. The test leads are made of the A material, while the source under test is the B material. The temperatures between the junctions are shown as T_1 and T_2 . To determine the thermal EMF generated, the following relationship may be used:

$$E_T = Q_{AB} (T_1 - T_2)$$

Where: E_T = Generated thermal EMF
 Q_{AB} = Thermoelectric coefficient of material A with respect to material B (μ V/ $^{\circ}$ C)
 T_1 = Temperature of B junction ($^{\circ}$ K or $^{\circ}$ C)
 T_2 = Temperature of A junction ($^{\circ}$ K or $^{\circ}$ C)

In the unlikely event that the two junction temperatures are identical, no thermal EMFs will be generated. More often, the two junction temperatures will differ, and considerable thermal EMFs will be generated.

A typical test setup will probably have several copper-to-copper junctions. As pointed out earlier, each junction can have a thermoelectric coefficient as high as 0.2 μ V/ $^{\circ}$ C. Since the two materials will frequently have a several degree temperature differential, it is easy to see how thermal potentials of several microvolts can be generated even if reasonable precautions are taken.

Minimizing Thermal EMFs

To minimize thermal EMFs, use only copper wires, lugs, and test leads for the entire test setup. Also, it is imperative that all connecting surfaces are kept clean and free of oxides. As noted in Table 3-13, copper-to-copper oxide junctions can result in thermal EMFs as high as 1mV/ $^{\circ}$ C.

Even when low-thermal cables and connections are used, thermal EMFs can still be a problem in some cases. It is es-

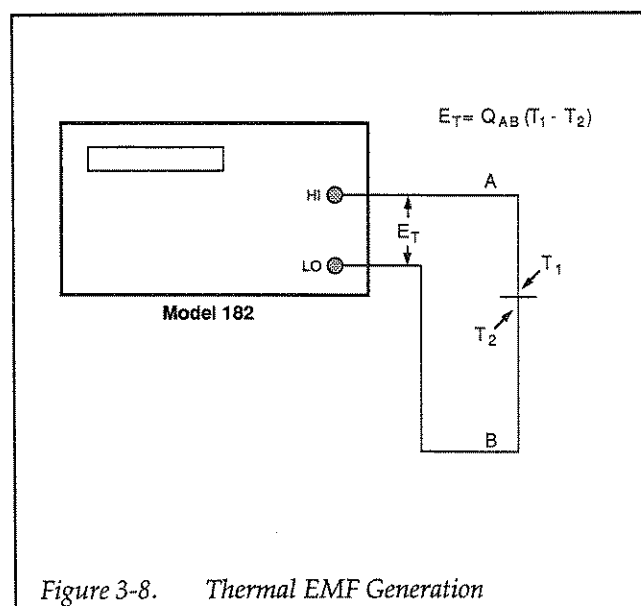

Figure 3-8. Thermal EMF Generation

pecially important to keep the two materials forming the junction at the same temperature. Keeping the two junctions close together is one way to minimize such thermal problems. Also, keep all junctions away from air currents; in some cases, it may be necessary to thermally insulate sensitive junctions to minimize temperature variations. When a Cu – Cu connection is made, sufficient pressure must be applied to ensure the connection is gas tight to prevent future oxidation.

In some cases, connecting the two thermal junctions together with good thermal contact to a common heat sink may be required. Unfortunately, most good electrical insulators are poor conductors of heat. In cases where such low thermal conductivity may be a problem, special insulators that combine high electrical insulating properties with high thermal conductivity may be used. Some examples of these materials include: hard anodized aluminum, sapphire, and diamond.

Nulling Residual Thermal Offsets

Even if all reasonable precautions are taken, some residual thermal offsets may still be present. These offsets can be minimized by using the Model 182 relative feature to null them out. To do so, place the instrument on the 3mV range and short the end of the connecting cable nearest the measured source (first disconnect the cable from the source to avoid shorting out the source). After allowing the reading to settle, press the front panel REL READING button to null the offset. Select the appropriate range, and make your measurement as usual. Note that it may be necessary to use relative often to counteract instrument or thermal drifts.

3.12.2 Source Resistance Noise

Noise present in the source resistance is often the limiting factor in the ultimate resolution and accuracy of Model 182 measurements. The paragraphs below discuss the generation of Johnson noise as well as ways to minimize such noise.

Johnson Noise Equation

The amount of noise present in a given resistance is defined by the Johnson noise equation as follows:

$$E_{RMS} = \sqrt{4kTRF}$$

Where: E_{RMS} = RMS value of the noise voltage
 k = Boltzman's constant ($1.38 \times 10^{-23} \text{J}/^\circ\text{K}$)
 T = Temperature ($^\circ\text{K}$)
 R = Source resistance (ohms)
 F = Noise bandwidth (Hz)

At a room temperature of 293°K (20°C), the above equation simplifies to:

$$E_{RMS} = 1.27 \times 10^{-10} \sqrt{RF}$$

Since the peak to peak noise is five times the RMS value 99% of the time, the peak to peak noise can be equated as follows:

$$E_{P-P} = 6.35 \times 10^{-10} \sqrt{RF}$$

For example, with a source resistance of 10kΩ, the noise over a 0.5Hz bandwidth at room temperature will be:

$$E_{P-P} = 6.35 \times 10^{-10} \sqrt{(10 \times 10^3)(0.5)}$$

$$E_{P-P} = 45\text{nV}$$

Minimizing Source Resistance Noise

From the above examples, it is obvious that noise can be reduced in several ways: (1) lower the temperature; (2) reduce the source resistance; and (3) narrow the bandwidth. Of these three, lowering the resistance is the least practical because the signal voltage will be reduced more than the noise. For example, decreasing the resistance of a current shunt by a factor of 100 will also reduce the signal voltage by a factor of 100, but the noise will be decreased only by a factor of 10.

Very often, cooling the source is the only practical method available to reduce noise. Again, however, the available reduction is not as large as it might seem because the reduction is related to the square root of the change in temperature. For example, to cut the noise in half, the temperature must be decreased from 293°K to 73.25 °K, a four-fold decrease.

3.12.3 Magnetic Fields

When a conductor loop cuts through magnetic lines of force, a very small current is generated. This phenomenon will frequently cause unwanted signals to occur in the test leads of a test system. If the conductor has sufficient length or cross-sectional area, even weak magnetic fields such as those of the earth can create sufficient signals to affect low-level measurements.

Three ways to reduce these effects are: (1) reduce the lengths of the connecting cables, and (2) minimize the exposed circuit area, and (3) change the orientation of the leads or cables. In extreme cases, magnetic shielding may be required. Special metal with high permeability at low flux densities (such as mu metal) are effective at reducing these effects.

Even when the conductor is stationary, magnetically-induced signals may still be a problem. Fields can be produced by various sources such as the AC power line voltage. Large inductors such as power transformers can generate substantial magnetic fields, so care must be taken to keep the Model 182, voltage source, and connecting cables a good distance away from these potential noise sources.

3.12.4 Radio Frequency Interference

RFI (Radio Frequency Interference) is a general term used to describe electromagnetic interference over a wide range of frequencies across the spectrum. Such RFI can be particularly troublesome at low signal levels, but it can also affect measurements at high levels if the fields are of sufficient magnitude.

RFI can be caused by steady-state sources such as radio or TV signals, or some types of electronic equipment (microprocessors, high speed digital circuits, etc.), or it can result from impulse sources, as in the case of arcing in high-voltage environments. In either case, the effect on the measurement can be considerable if enough of the unwanted signal is present.

RFI can be minimized in several ways. The most obvious method is to keep the Model 182, voltage source, and signal leads as far away from the RFI source as possible. Additional shielding of the instrument, signal leads, sources, and other measuring instruments will often reduce RFI to an acceptable level. In extreme cases, a spe-

cially-constructed screen room may be required to sufficiently attenuate the troublesome signal.

The Model 182 digital filter may help to reduce RFI effects in some situations. In some cases, additional external filtering may also be required. Keep in mind, however, that filtering may have detrimental effects such as increased settling time on the desired signal.

3.12.5 Ground Loops

When two or more instruments are connected together, care must be taken to avoid unwanted signals caused by ground loops. Ground loops usually occur when sensitive instrumentation is connected to other instrumentation with more than one signal return path such as power line ground. As shown in Figure 3-9, the resulting ground loop causes current to flow through the instrument LO signal leads and then back through power line ground. This circulating current develops a small, but undesirable voltage between the LO terminals of the two instruments. This voltage will be added to the source voltage, affecting the accuracy of the measurement.

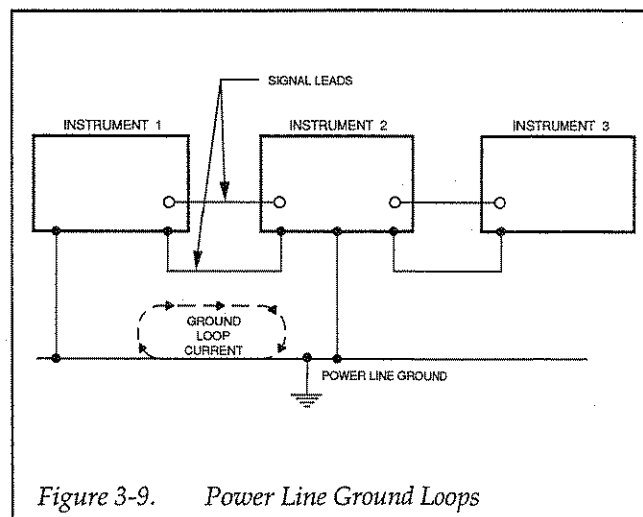

Figure 3-9. Power Line Ground Loops

Figure 3-10 shows how to connect several instruments together to eliminate this type of ground loop problem. Here, only one instrument is connected to power line ground.

Ground loops are not normally a problem with instruments like the Model 182 that have isolated LO terminals. However, all instruments in the test setup may not be designed in this manner. When in doubt, consult the manual for all instrumentation in the test setup.

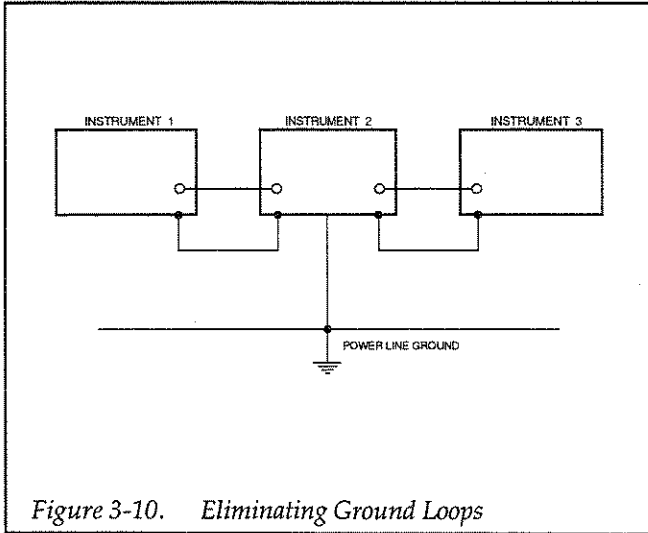

Figure 3-10. Eliminating Ground Loops

3.12.6 Shielding

Proper shielding of all signal paths and sources being measured is important to minimize noise pickup in virtually any low-level measurement situation. Otherwise, in-

terference from such noise sources as line frequency and RF fields can seriously corrupt measurements, rendering experimental data virtually useless.

In order to minimize noise, a closed metal shield, surrounding the source, may be necessary, as shown in the example of Figure 3-11. This shield should be connected to input LO in most cases, although better noise performance may result with the shield connected to chassis ground in some situations.

WARNING

Do not float input LO more than 30V RMS, 42.4V peak above earth ground with an exposed shield connected to input LO. To avoid a possible shock hazard, surround the LO shield with a second, safety shield that is insulated from the inner shield. Connect this safety shield to safety earth ground using #18 AWG minimum wire before use.

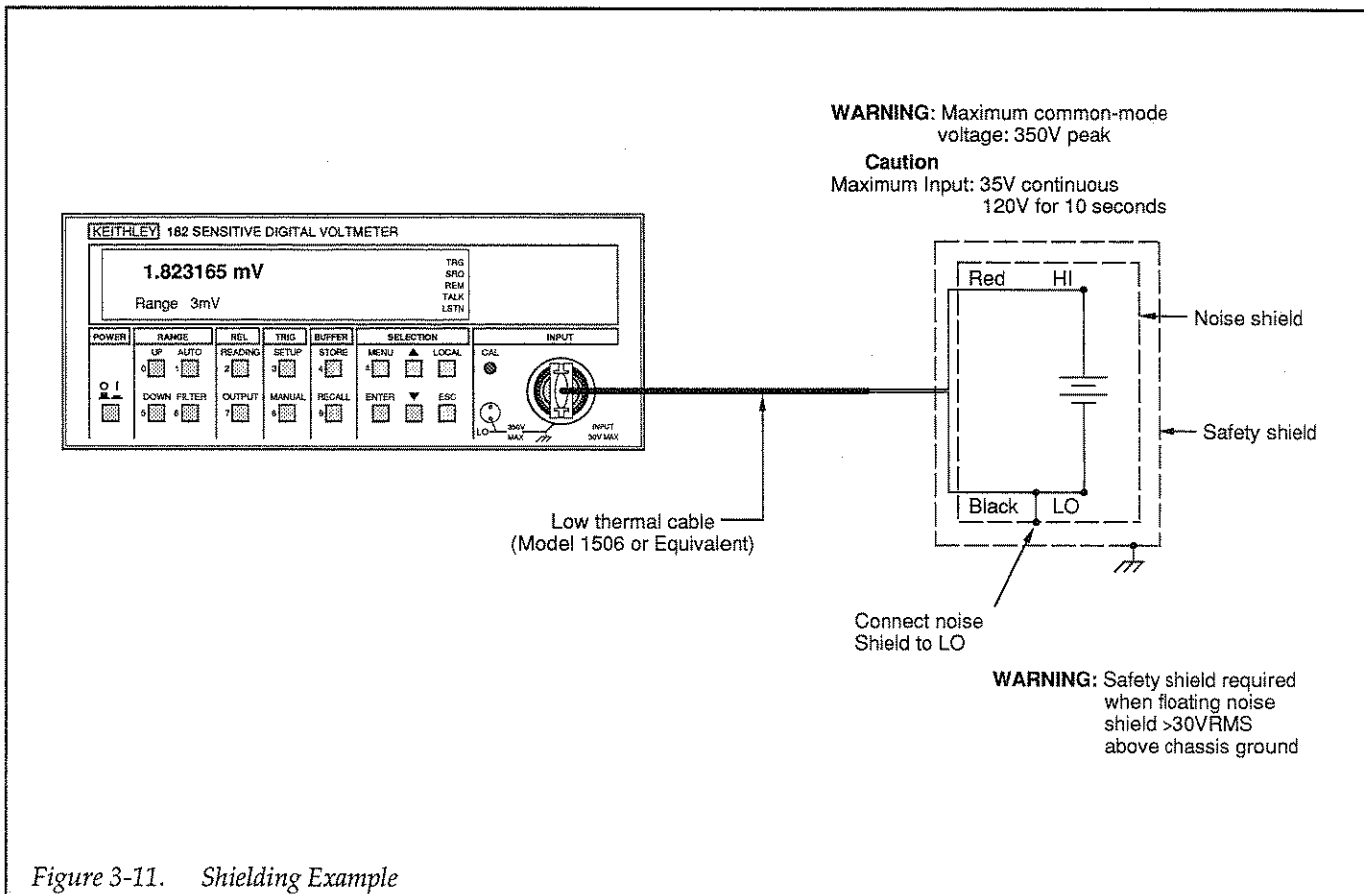

Figure 3-11. Shielding Example

3.12.7 Meter Loading

Loading of the voltage source by the Model 182 becomes a consideration for high source resistance values. As the source resistance increases, the error caused by meter loading increases.

Figure 3-12 shows the method used to determine the percent error due to meter loading. The voltage source, V_s , has a source resistance, R_s , while the input resistance of the Model 182 is R_i , and the voltage measured by the nanovoltmeter is V_M .

The voltage actually measured by the meter is attenuated by the voltage divider action of R_s and R_i , and it can be calculated as follows:

$$V_M = \frac{V_s R_i}{R_i + R_s}$$

This relationship can be modified to directly compute for percent error:

$$\text{Percent error} = \frac{100 R_s}{R_i + R_s}$$

From the above equation, it is obvious that the input resistance of the Model 182 must be at least 999 times the value of source resistance if loading error is to be kept to within 0.1%.

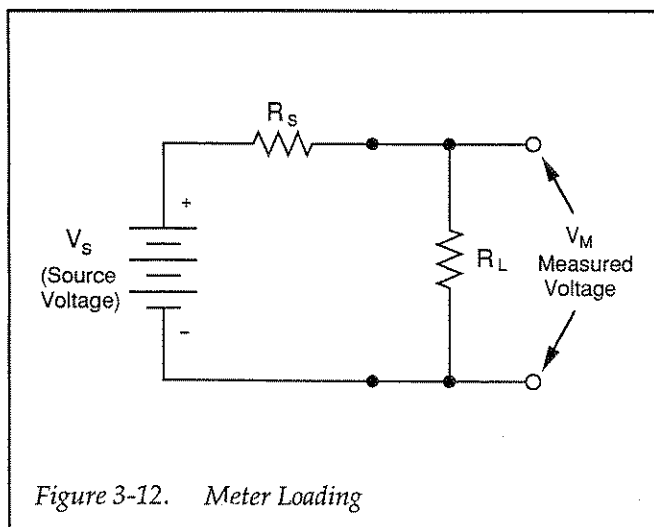

3.13 APPLICATIONS

3.13.1 Low-resistance Measurements

The Model 182 can be used with a current source to measure resistances at levels well below the capabilities of most conventional instruments. The following paragraphs discuss low-resistance measurement techniques and outline a typical low-resistance test system.

Low-resistance Measurement Techniques

Techniques used to measure resistances in the normal range are not generally suitable for making low-resistance measurements because of errors caused by voltage drops across the test leads. To overcome these limitations, low resistance measurements are usually made using the 4-wire (Kelvin) connections shown in Figure 3-13. A current source forces the current (I) through an unknown resistance, developing a voltage across that device. Even though the test lead resistance, R_{LEAD} , is present, it does not affect the current through R_{DUT} because I is assumed to be a constant current source with high output impedance. Also, if the voltmeter has a very high input resistance, the current through the sense leads will be negligible, and the voltage drop across R_{LEAD} will be essentially zero. Thus, the voltage measured by the meter will be essentially the same as the voltage across the unknown resistance, R_{DUT} .

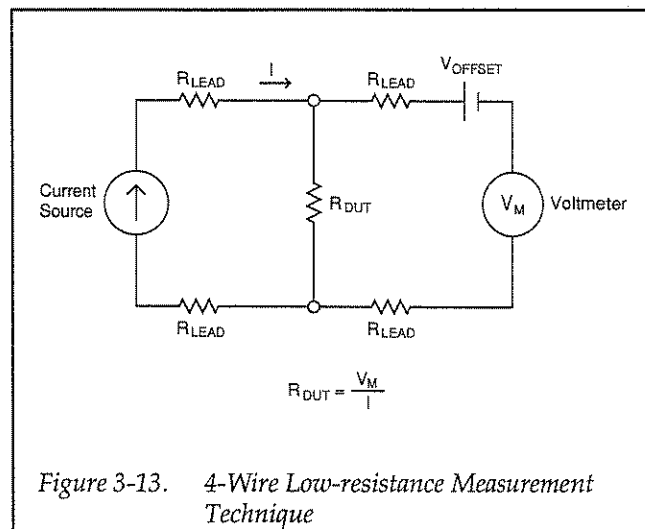

Since the current through the measured resistance and the voltage across the device are both known, the value of that resistance can easily be determined from Ohm's law:

$$R_{DUT} = \frac{V_M}{I}$$

It can be seen that the sensitivity of the measurement depends on both the current source value and the resolution of the voltage-measuring instrument. Using the Model 182 and this measurement technique, resistance changes as low as $0.1\mu\Omega$.

Compensating For Thermal EMFs

Although the 4-wire measurement method minimizes the effects of lead resistances, other factors can affect low-resistance measurement accuracy. Thermal EMFs, and other effects can add an extraneous DC offset voltage (V_{OFFSET} in Figure 3-13) to the measured voltage. One method that can be used to cancel this offset is to first apply a positive current and then a negative current of the same magnitude (I). As each current is applied, the voltage across the device (DUT) is measured.

For a positive current, the resulting voltage is:

$$V_{X+} = IR_{DUT} + V_{OFFSET}$$

For a negative current, the voltage across the device becomes:

$$V_{X-} = -IR_{DUT} + V_{OFFSET}$$

The difference between these two voltages is:

$$\begin{aligned} V_{X+} - V_{X-} &= (IR_{DUT} + V_{OFFSET}) - (-IR_{DUT} + V_{OFFSET}) \\ &= 2IR_{DUT} \end{aligned}$$

Note that the term, V_{OFFSET} , is cancelled out in the above equation.

Once the voltage difference is known, the device resistance can then be calculated as follows:

$$R_{DUT} = (V_{X+} - V_{X-}) / 2I$$

Note that the DC offset voltage is effectively cancelled as long as it remains comparatively steady. If the offset volt-

age varies, it may be advantageous to take a number of such readings and average them.

Typical Low-Resistance Test System

A typical low-resistance test system using the Model 182 is shown in Figure 3-14. The current is supplied by a Model 220 Programmable Current Source. The Model 220 includes a standard IEEE-488 interface and contains an internal 100-location memory which can be programmed for presettable currents, voltage compliances, and dwell times. The Model 220 is capable of supplying positive and negative currents for four-quadrant measurements.

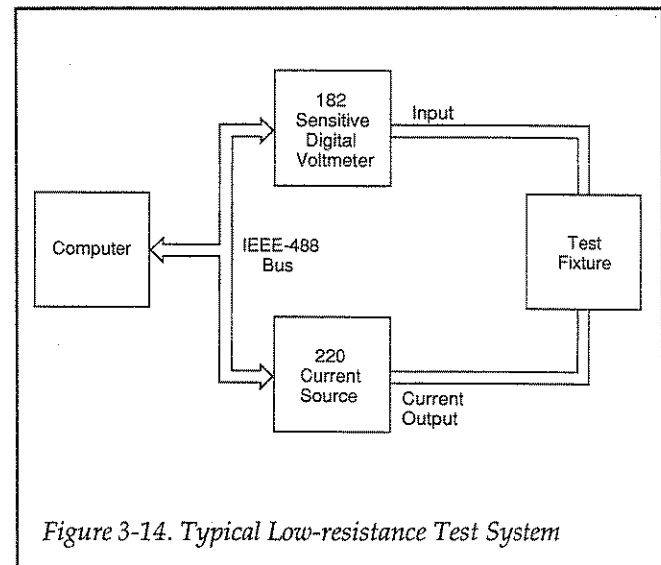

Figure 3-14. Typical Low-resistance Test System

The two instruments can be interfaced to a computer via the IEEE-488 bus. This arrangement would not only provide the computational capability necessary to calculate the resistance, but it would also allow automated control of low-resistance test procedures.

Typical Test Connections

Typical test connections for the Model 182 and the Model 220 Current Source are shown in Figure 3-15. A Model 8003 Test Fixture is used for this configuration because it is designed specifically for low-resistance measurements. Triax cabling is used between the test fixture and the Model 220 Current Source, while the requisite low-thermal cable is used for Model 182 connections. All necessary cables are included with the Model 8003.

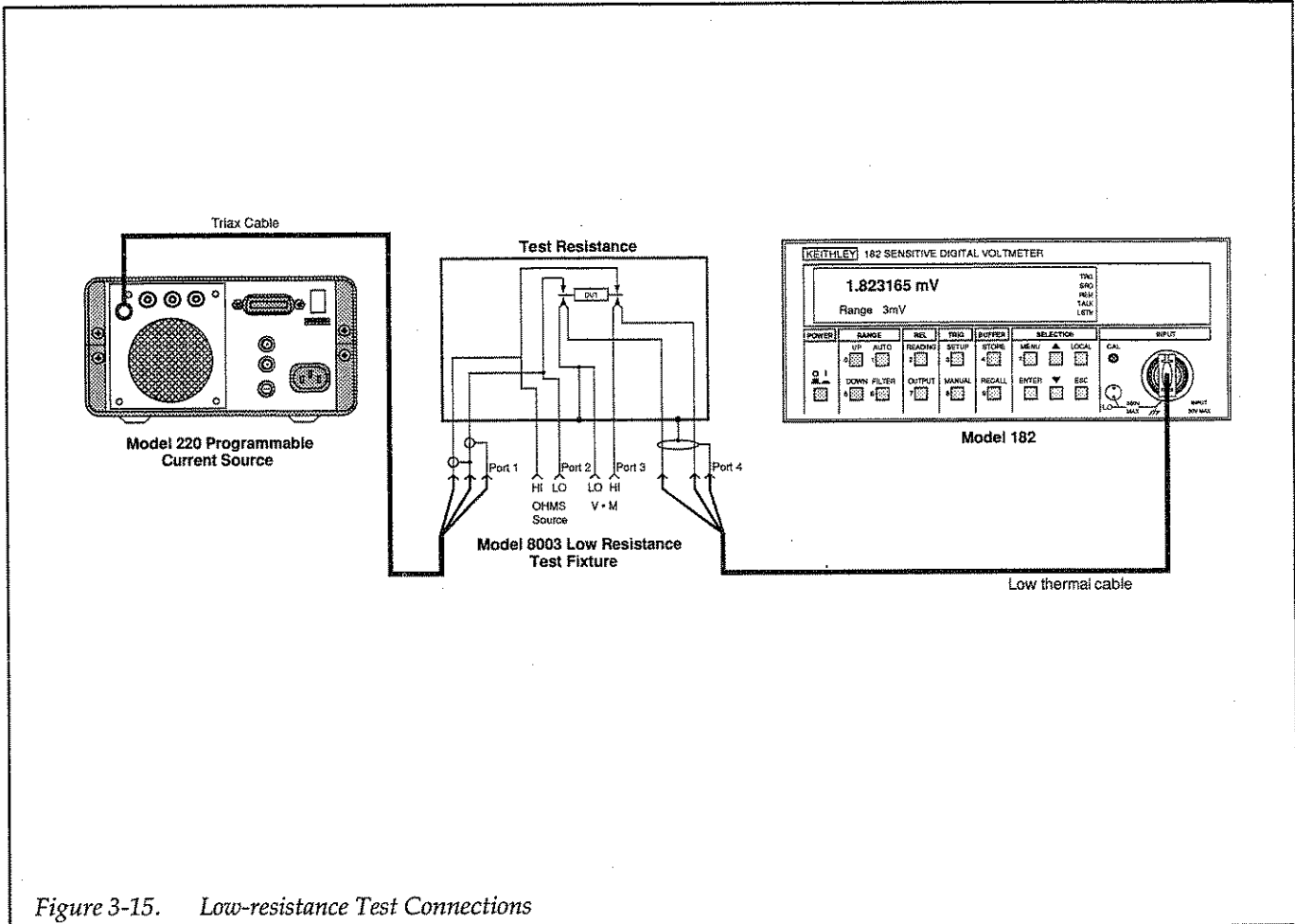

Figure 3-15. Low-resistance Test Connections

3.13.2 Low-Voltage Scanning

The Model 182 can be used with a low-voltage scanning card to test multiple low-voltage devices without having to manually change test connections. By adding a controller and suitable software, such tests can be performed automatically with little or no operator intervention.

Basic Low-voltage Scanning System

A basic low-voltage scanning test system is shown in

Figure 3-16. In addition to the Model 182, which measures the test voltages, the system also includes a Model 7168 nV Scanner Card and a Model 705 Scanner. The Model 7168 switches among the eight DUTs, while the Model 705 controls the scanner card. Both the scanner and the Model 182 are shown connected to a controller via the IEEE-488 bus, although computer control is optional and would not be required for simpler test procedures.

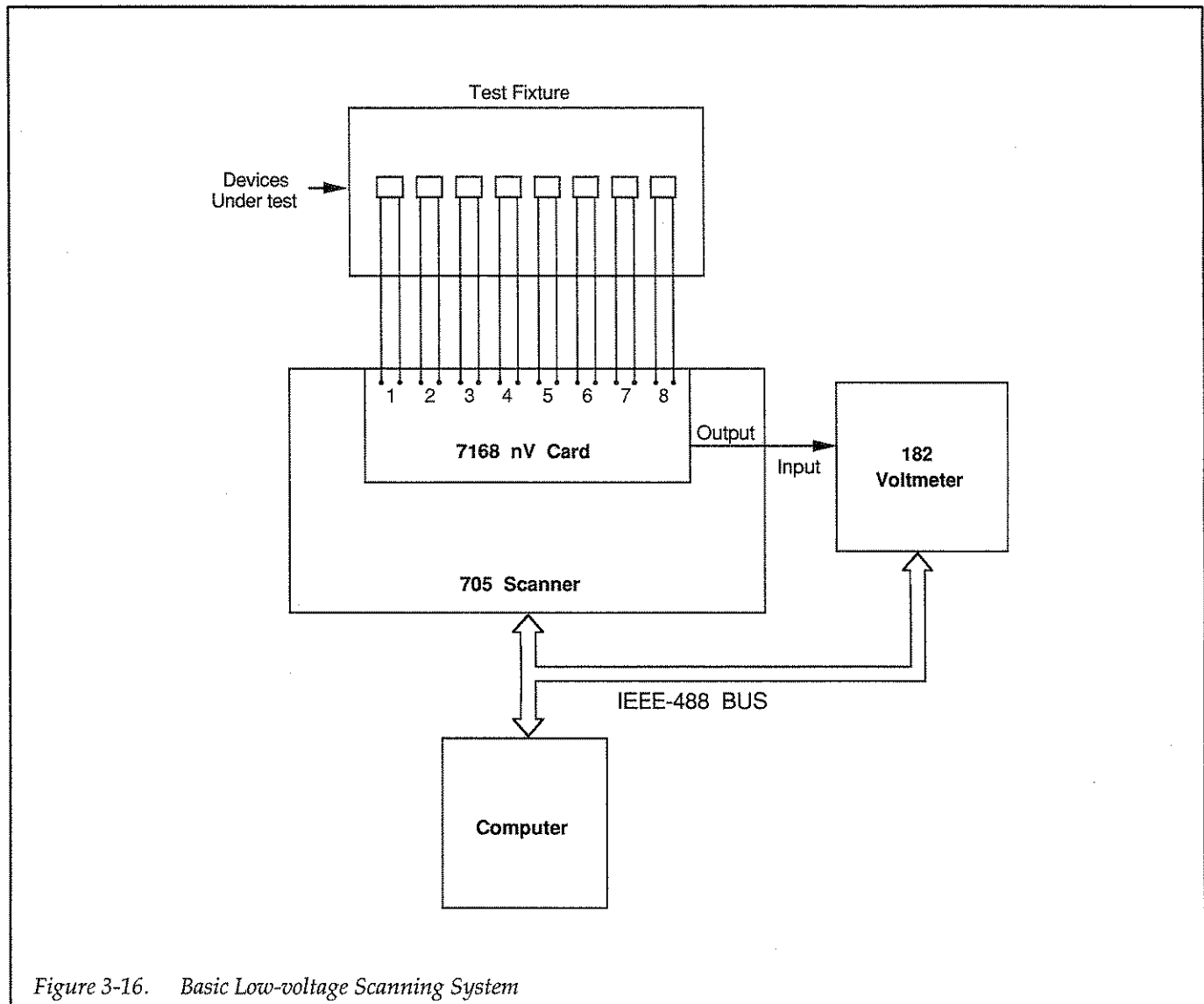

Figure 3-16. Basic Low-voltage Scanning System

Practical Low-voltage Scanning Applications

Figure 3-17 shows a low-voltage scanning system used to test thermocouples. In addition to the scanner, scanner card, and the Model 182, the system also includes an oil bath and temperature controller to set the thermocouples to the desired temperature. A computer is used to control the instruments and to provide computational capability.

Figure 3-18 shows a multiple-DUT low-resistance test system. The current source forces the current through all eight DUTs simultaneously, while the scanner card

switches among the various devices for measurement. The Model 182, of course, measures the voltage across each DUT and sends the resulting readings back to the computer. The basic test procedure and calculations are carried out as discussed in paragraph 3.13.1.

3.13.3 Josephson Junction Array Measurements

The Model 182 Sensitive Digital Voltmeter can be used for Josephson junction voltage array measurements for calibration and intercomparison.

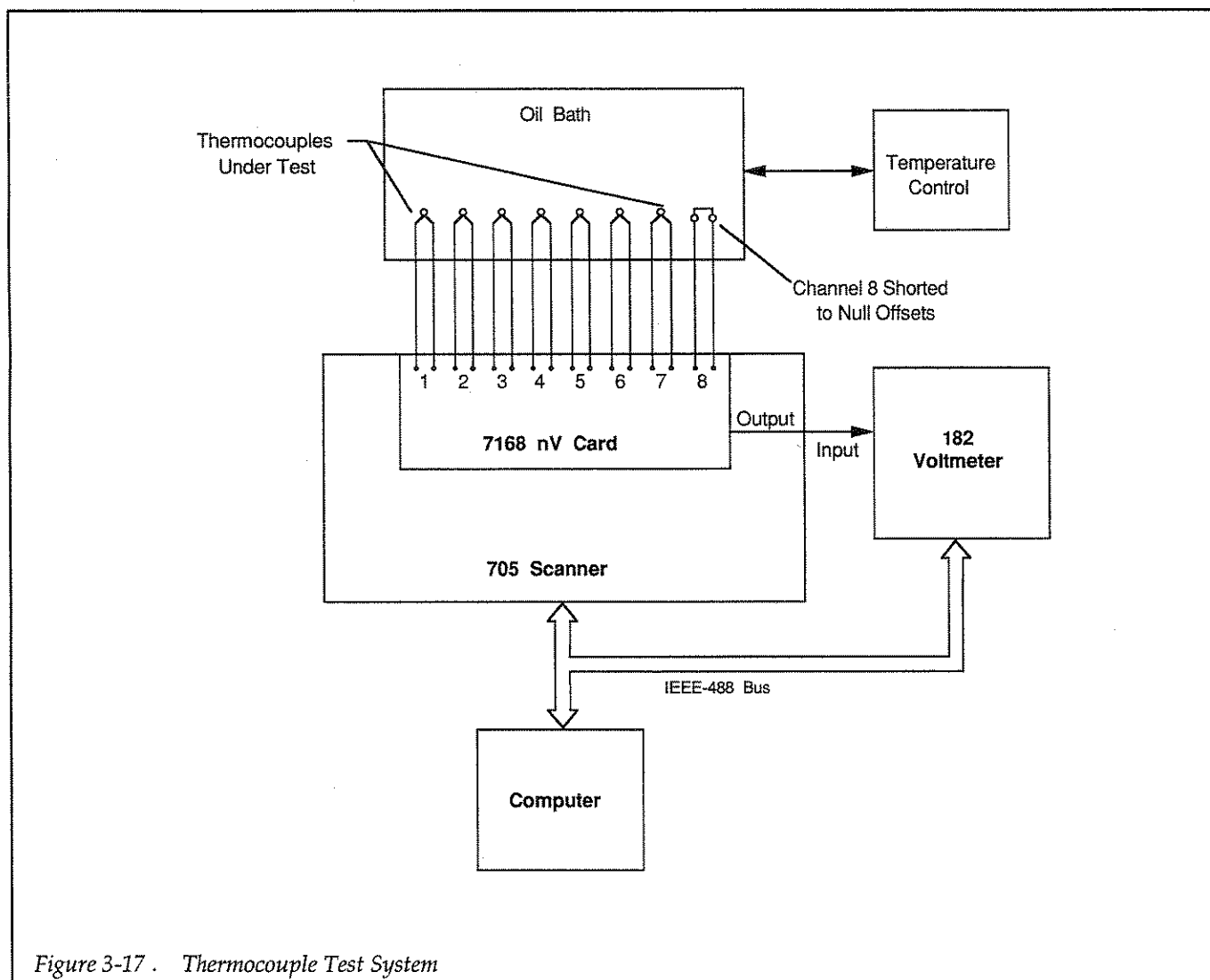

Figure 3-17. Thermocouple Test System

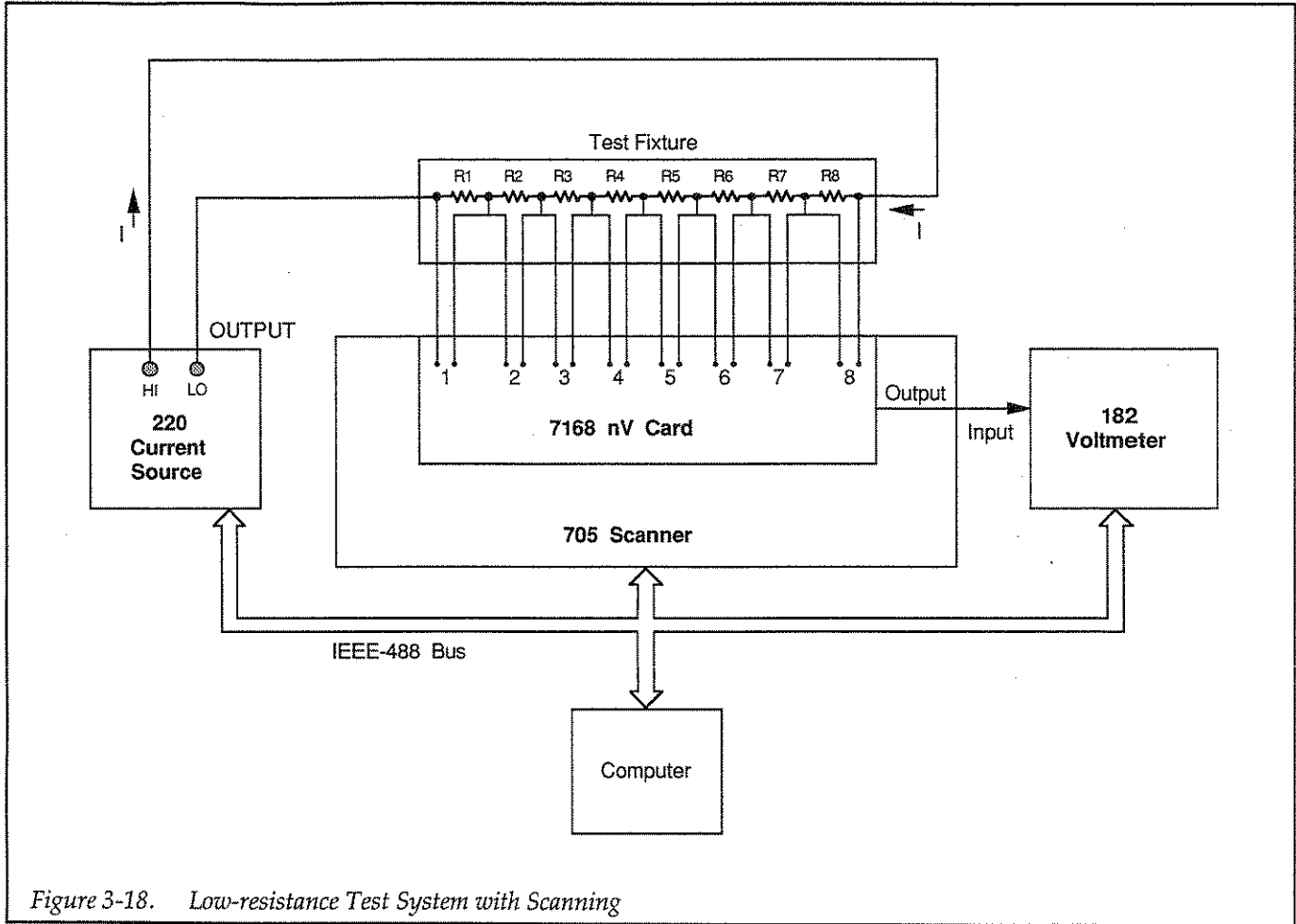

Figure 3-18. Low-resistance Test System with Scanning

Interference Considerations

Josephson junction measurements are particularly vulnerable to the effects of high-frequency EMI (Electromagnetic Interference) and RFI. High-frequency coupling of unwanted RFI or EMI can significantly affect the I-V characteristics of the device, rendering the data useless in many cases. Some of this interference can come from the instrumentation itself, while other interference signals come from the outside environment. Regardless of the source, care must be taken to minimize the coupling of these unwanted signals to the DUT.

Minimizing Interference

The Model 182 has been designed to minimize the coupling of RFI through the INPUT test leads to the DUT. However, additional steps may be required to reduce RFI effects to an acceptable level.

Two methods which are recommended for minimizing RFI effects are shown in Figure 3-19. First, the DUT is placed in a shielded enclosure, which is connected to earth ground. Note that the HI and LO leads are bypassed to earth ground using suitable capacitors.

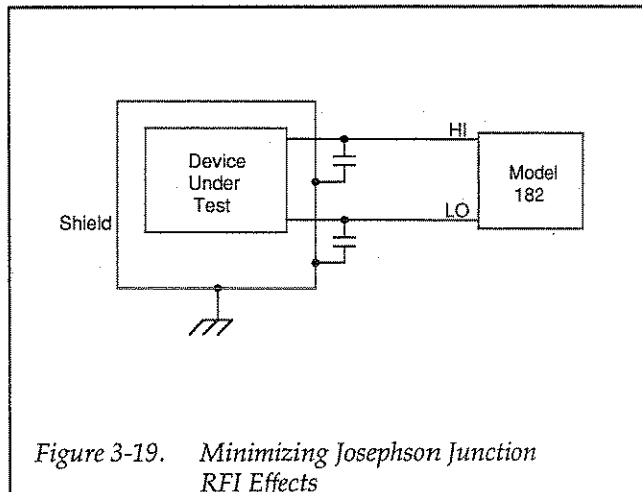

Figure 3-19. Minimizing Josephson Junction RFI Effects

SECTION 4

IEEE-488 Reference

4.1 INTRODUCTION

This section contains reference information on programming the Model 182 over the IEEE-488 bus. Detailed instructions for all programmable functions are included; however, information concerning operating modes presented elsewhere is not repeated here. Refer to Sections 2 and 3 for information not found in this section.

General information on the IEEE-488 bus is located in the Appendix.

This section is arranged as follows:

4.2 Device-dependent Commands: Describes the device-dependent commands that control the instrument over the bus.

4.3 General Commands: Covers the IEEE-488 general commands required for such operations as placing the unit in remote and returning the instrument to default conditions.

4.4 Bus Connections: Details connecting the instrument to the IEEE-488 bus.

4.5 Primary Address Programming: Gives the procedure for programming the primary address from the front panel.

4.6 Front Panel Aspects of IEEE-488 Information: Covers front panel aspects such as display messages, status indicators, and using the LOCAL key.

4.2 DEVICE-DEPENDENT COMMANDS

IEEE-488 device-dependent commands control most instrument operating modes. All Model 182 front panel operations (such as range and resolution), as well as some operations not available from the front panel (such as reading format and SRQ) can be programmed with these commands.

Command Syntax

Each command consists of a single ASCII letter followed by one or more numbers representing an option or numeric parameter of that command. For example, the range can be programmed over the bus by sending the letter "R" followed by a number representing the range option. R5X would be sent to select the 30V range.

Note that the Model 182 will accept either upper-or lower-case characters for command letters. Lower-case letters perform the same operations as the corresponding upper-case letters. For example, r1x and R1X perform the identical operation of selecting the 3mV range.

Multiple-option Commands

Some commands have two options that must be delimited (separated) by commas. For example, the command

V0,10X programs the analog output for normal operation and sets the analog output gain to 10, while Z2,2.2X enables the reading relative function, using a parameter of 2.2 as the relative value. Note that you must specify both options in two-option commands, even if you are changing only one option.

Multiple Commands

A number of commands can be grouped together in one command string, which is generally terminated by the "X" (execute) command character. This character tells the instrument to execute the command or command string, as described in paragraph 4.2.23. Commands sent without the execute character will not be executed at that particular time, but they will be stored within an internal command buffer for later execution when the execute character is later received. Note that any spaces (ASCII 32) and other "white space" characters (discussed below) in the command string will be ignored.

Numeric Command Options

Numeric command options may be specified either as an integer or as a floating-point number. Command options that are defined as integers, but sent as floating-point numbers will be internally converted to integers. An INVALID OPTION error will be generated if an integer overflow occurs.

A mantissa can have any number of leading or trailing zeroes, but it is limited to a maximum length of 98 significant digits. The mantissa will be truncated to a length of 11 significant digits. An exponent can have any number of leading zeroes, but it is limited to a maximum of two significant digits.

Invalid Commands

If an invalid command or command option is sent as part of the command string, no commands in the string will be executed. Under these conditions, the instrument will display a front panel error message (INVALID COMMAND, INVALID FORMAT, or INVALID OPTION) and it can be programmed to generate an SRQ (Service Request), as discussed in paragraph 4.2.12. Front panel error messages are covered in paragraph 4.5.1.

Some typical examples of valid command strings include:

R0X Single command followed by execute command.
Y3T0P0X Multiple command string.
Z 1X Space is ignored,
V0,10X Multiple-parameter command string (parameters separated by comma).

Typical invalid command strings include:

E1X Invalid command, as E is not one of the instrument's valid commands.
K4X Invalid command option because 4 is not a valid option of the K command.

Command White Space Characters

The following ASCII characters are considered to be "white space" characters and are ignored by the command parser (values shown are decimal): 32-47, 58-64, 91-96, and 123-127.

Device-dependent Command Summary

Model 182 device-dependent commands are summarized in Table 4-1, which also lists respective paragraphs where more detailed information on each command is located.

Order of Command Execution

Device-dependent commands are not necessarily executed in the order received. Rather, the instrument executes them in a specific order, as summarized in Table 4-2. The order shown in the table assumes that the "X" character appears only once at the end of a multiple command string.

If you wish to force a particular order of execution, simply include the execute (X) character after each command-option grouping in the command string. For example, the following string would be executed in the received order:

R0XT2XM1XK0X

Table 4-1. Device-Dependent Command Summary

Mode	Command	Description	Para.
Display ASCII String	A0 A1,string A2,string A3	Restore display to normal Display string Display string and store in EEROM Display string stored in EEROM	4.2.1
Display Resolution	B0 B1 B2 B3	5 1/2-digit resolution 6 1/2-digit resolution 3 1/2-digit resolution 4 1/2-digit resolution	4.2.2
Measure and Analog Output Source Calibration	C0,value C1,value C2 C3,value C4 C5 C6,value C7 C8,value	Calibrate measure positive full scale Calibrate measure negative full scale Calibrate measure zero offset Calibrate divider full scale Calibrate divider zero Select positive full scale output Calibrate positive full scale output Select zero output value Calibrate zero output with value	4.2.3
Filter Damping	D0 D1	Configure filter damping off (same as P2) Configure filter damping on (same as P3)	4.2.4
Reading Source	F0 F1 F2 F3 F4	Latest reading from A/D converter One reading from buffer All readings in buffer Maximum value in buffer Minimum value in buffer	4.2.5
Reading Format	G0 G1 G2 G3 G4 G5 G6 G7	Reading only Reading with prefix Reading with buffer location Reading with buffer location and prefix Reading with time stamp Reading with time stamp and prefix Reading with time stamp and location Reading with time stamp,location,and prefix	4.2.6
Immediate Trigger and Self-test	H0 H1	Initiate manual trigger Perform memory test	4.2.7
Buffer Configuration	I0 I1,value I2	Disable buffer Buffer on, linear length=value Buffer on, circular length=1024	4.2.8

Table 4-1. Device-Dependent Command Summary (Continued)

Mode	Command	Description	Para.
Analog Output Relative	J0 J1 J2,value J3	Disable analog output relative Enable analog output relative using next reading Enable analog output relative using value ($\pm 1E-9$ to ± 30.3) Enable analog output relative, use present value	4.2.9
EOI, Bus Hold-off	K0 K1 K2 K3	Enable EOI, enable bus hold-off on X Disable EOI, enable bus hold-off on X Enable EOI, disable bus hold-off on X Disable EOI, disable bus hold-off on X	4.2.10
Save/Recall Setup	L0 L1 L2	Save current setup as power-on Recall factory default setup Recall power-on setup	4.2.11
SRQ Mask	M0 M1 M2 M4 M8 M16 M32 M128	Disable SRQ Reading done Buffer half full Buffer full Reading overflow Ready for command Error Ready for trigger	4.2.12
Enable/Disable Filters	N0 N1	Filters off Filters on	4.2.13
Analog Filter Configuration	O0 O1	Configure analog filter off Configure analog filter on	4.2.14
Digital Filter Configuration	P0 P1 P2 P3	Configure digital filter off Configure fast response Configure medium response Configure slow response	4.2.15
Trigger Interval	Qvalue	Interval=value in msec (10-999 999msec)	4.2.16
Range	R0 R1 R2 R3 R4 R5 R6 R7 R8	Enable auto-range 3mV range 30mV range 300mV range 3V range 30V range No function No function Disable auto-range	4.2.17

Table 4-1. Device-Dependent Command Summary (Continued)

Mode	Command	Description	Para.
Integration Period	S0 S1 S2	Line cycle integration period 3msec integration period 100msec integration period	4.2.18
Trigger Mode and Source	T0 T1 T2 T3 T4 T5 T6 T7 T8 T9 T10	Multiple on talk One-shot on talk Multiple on GET One-shot on GET Multiple on X One-shot on X Multiple on external One-shot on external Multiple on manual (MANUAL key) or bus H0X One-shot on manual (MANUAL key) or bus H0X Disable all triggers	4.2.19
Alternate Output	U0 U1 U2 U3 U4 U5 U6 U7 U8 U9 U10 U11 U12 U13 U14	Send machine status Send error conditions Send firmware revision Send buffer length Send buffer average Send buffer standard deviation Send reading relative value Send analog output relative value Send analog output gain value Send trigger interval Send trigger delay Send calibration constants Send calibration lock status Send Model 181-like machine status Send ASCII text string	4.2.20
Analog Output Mode, Gain, and Output Value	V0,gain V1,value	Normal mode, gain (.001–999 999.999) Source mode, output=value (–3.3 to +3.3)	4.2.21
Trigger Delay	W0 Wvalue	Disable trigger delay Enable trigger delay, delay=value (1msec to 999 999 msec)	4.2.22
Execute	X	Execute other device-dependent commands	4.2.23
Terminators	Y0 Y1 Y2 Y3 Y10 Y13	<CR LF> <LF CR> <CR> <LF> <CR LF> <LF CR>	4.2.24
Reading Relative	Z0 Z1 Z2,value Z3	Disable reading relative Enable reading relative using next reading Enable reading relative using value ($\pm 1E-9$ to ± 30.3) Enable reading relative, use present value	4.2.25

NOTE: Corresponding lower-case letters may be used instead of upper-case letters.

Table 4-2. Heirarchy of Command Execution

Order	Command	Description
1	M	SRQ mask
2	R	Range
3	C	Meter, analog output calibration
4	A	Display message
5	B	Display resolution
6	O	Analog filter
7	P	Digital filter
8	D	Damping
9	S	Integration period
10	I	Buffer configuration
11	G	Reading format
12	F	Reading source
13	Z	Reading relative
14	V	Analog output source,gain,value
15	J	Analog output relative
16	T	Trigger mode and source
17	Q	Trigger interval
18	W	Trigger delay
19	Y	Terminators
20	K	EOI, bus hold-off on X
21	U	Alternate output
22	L	Recall
23	N	Enable filters
24	H	Immediate trigger,self-test
25	X	Execute

4.2.1 A — Display ASCII String

Purpose To display user-defined front panel messages

Format An or An,string

Parameters

A0	Restore normal display
A1,string	Display string
A2,string	Display string and store in EEROM
A3	Display string stored in EEROM

Default Upon power-up, or after receiving a DCL or SDC command, the display always returns to normal.

Description The A command allows you to display messages on the front panel by sending them as ASCII strings over the bus. A1,string displays the string of characters without storing the string in EEROM. A2,string stores the string in EEROM for later recall in addition to displaying it on the front panel. The string stored in EEROM can be recalled using the A3 command.

A message string is defined as a sequence of ASCII text characters surrounded by single quote characters, for example: 'Test Concluded'. Displayable characters include all standard ASCII text characters (32 through 127 decimal). Any characters which cannot be displayed will be replaced with space characters. In addition to the standard text, the following characters can be displayed:

Decimal Value	Displayed Character
16	μ
17	±
18	Ω
19	▲
20	▼
21	→

Programming Notes

1. Error messages overwrite a user display message.
2. In addition to using A0X, the display can be returned to normal by performing sending DCL or SDC.
3. An X character included in a string between single quote characters will be displayed and will not be interpreted as an execute command.
4. A message string stored in EEROM will be retained when the power is turned off.
5. A maximum of 49 display characters can be included in the A command string, not including the two single quote characters. Any excess characters will be ignored.
6. A single quote character can be displayed by preceding one single quote character in the command string immediately with another.

**Programming
Examples**

```
10 REMOTE 707                ! Put 182 in remote.
20 OUTPUT 707;"A2,MODEL 182'X" ! Display "MODEL 182".
30 PRINT "Press 'Cont'"      ! Prompt to continue.
40 PAUSE
50 OUTPUT 707;"A0X"          ! Return display to normal.
60 END
```

4.2.2 B — Display Resolution

Purpose To set the display resolution

Format Bn

Parameters

B0	5 1/2-digit display resolution
B1	6 1/2-digit display resolution
B2	3 1/2-digit display resolution
B3	4 1/2-digit display resolution

Default Upon power-up, or after receiving a DCL, SDC, or L2X command, the display resolution returns to the programmed default setting. The factory default setting is B1 (6 1/2-digit resolution).

Description The B command allows control of display resolution. Thus, the B command performs the same operation as the DISPLAY RESOLUTION selection available with the MENU key.

Programming Note The selected integration period affects the usable resolution of readings sent by the instrument. See paragraph 4.2.18.

Programming Examples

10	OUTPUT 707;"B2X"	! 3 1/2-digit resolution.
20	OUTPUT 707;"B1X"	! 6 1/2-digit resolution.
30	OUTPUT 707;"B0X"	! 5 1/2-digit resolution.

4.2.3 C — Measurement and Analog Output Calibration

Purpose To calibrate the measurement accuracy of the instrument, and to calibrate the analog output

Format Cn or Cn,value

Parameters

C0,value	Calibrate positive full scale measure with value
C1,value	Calibrate negative full scale measure with value
C2	Calibrate measure zero offset
C3,value	Calibrate divider full scale with value
C4	Calibrate divider zero
C5	Select positive full scale analog output
C6,value	Calibrate positive full scale analog output
C7	Select zero analog output value
C8,value	Calibrate zero analog output with value

Description The C command performs calibration of both measurement accuracy and the analog output. The C0, C1, and C2 commands together perform three-point calibration of each measurement range: positive full scale, negative full scale, and zero voltage (or shorted input). The C3 and C4 commands calibrate the measurement divider (which is used to calibrate the 3mV and 30mV ranges), and the C5 through C8 commands are used to calibrate the analog output.

Complete details on using these commands to calibrate the instrument are located in paragraph 7.3.

Programming Note Inadvertently sending the C command with calibration in the unlocked state may cause instrument miscalibration.

4.2.4 D — Filter Damping

Purpose To control digital filter damping

Format Dn

Parameters
D0 Turn digital filter damping off (same as P2)
D1 Turn digital filter damping on (same as P3)

Default Upon power-up, or after receiving a DCL, SDC, or L2X command, the instrument returns to the programmed default setting. The factory default setting is D0 (damping off).

Description The D command is a redundant command that controls filter damping. D1 performs the identical operation as P3, and D0 is the same as P2 (paragraph 4.2.15). The D command is included for software compatibility with the Model 181 Digital Nanovoltmeter.

Programming Note Details on digital filter operation are located in paragraph 3.7.

Programming Examples
10 OUTPUT 707;"D1X" ! Enable damping.
20 OUTPUT 707;"D0X" ! Disable damping.

4.2.5 F — Reading Source

Purpose To control the source of the readings the instrument sends over the bus

Format Fn

Parameters

F0	Latest reading from A/D converter
F1	One reading from buffer
F2	All readings from buffer
F3	Maximum value in buffer
F4	Minimum value in buffer

Default Upon power-up, or after receiving a DCL, SDC, or L1X or L2X command, the instrument returns to the factory default reading source, which is the A/D converter (F0).

Description The F command controls the source of readings the instrument sends over the IEEE-488 bus. With F0 and F1, a single reading will be sent from the A/D converter and buffer respectively each time the instrument is addressed to talk. In the F2 mode, all buffer readings will be sent for each talk command, with individual readings separated by commas. F3 and F4 return the maximum and minimum buffer values respectively.

General formats for the reading source commands are shown in Figures 4-1 through 4-4.

Programming Notes

1. The reading format (G) command discussed in paragraph 4.2.6 controls prefix, buffer location, and time stamp information associated with each reading.
2. The buffer must be enabled and must contain data before buffer reading information is available using the F1-F4 commands. See paragraph 4.2.8 for more details on buffer operation in the various F modes.
3. The selected reading source will remain active until changed by sending a different F command. It is not necessary to send the F command before each reading request.
4. With the F2 command, the programmed terminator and EOI will be sent only once at the end of the complete reading dump from the buffer. With all other reading sources, the programmed terminator and EOI will be sent after each reading.
5. With the F1 command, the buffer location will automatically increment each time you request a reading from the buffer.
6. When accessing normal readings (F0), the buffer location will always be equal to 0000, and the time stamp value will always be 000000.000sec.

Programming Examples

10	REMOTE 707	! Put 182 in remote.
20	OUTPUT 707;"I1,10X"	! Enable buffer,10 readings.
30	DIM R\$(1000)	! Dimension reading string.
40	FOR I =0 TO 4	! Loop for all sources.
50	OUTPUT 707;"F";I;"X"	! Program reading source.
60	ENTER 707;R\$! Input reading.
70	PRINT R\$! Display reading.
80	NEXT I	! Loop back for next format.
90	OUTPUT 707;"F0X"	! Restore A/D reading source.
100	END	

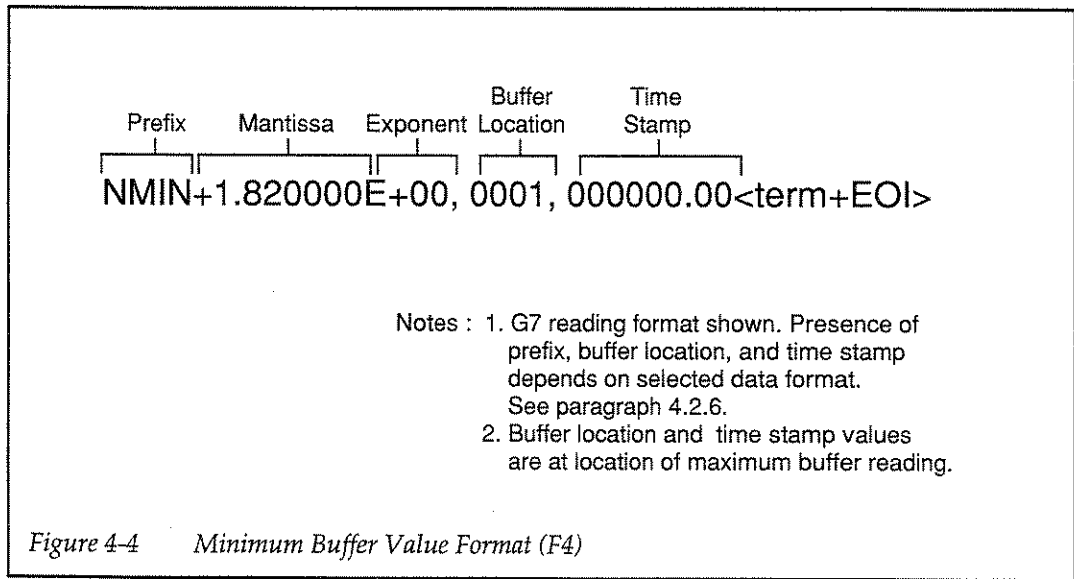
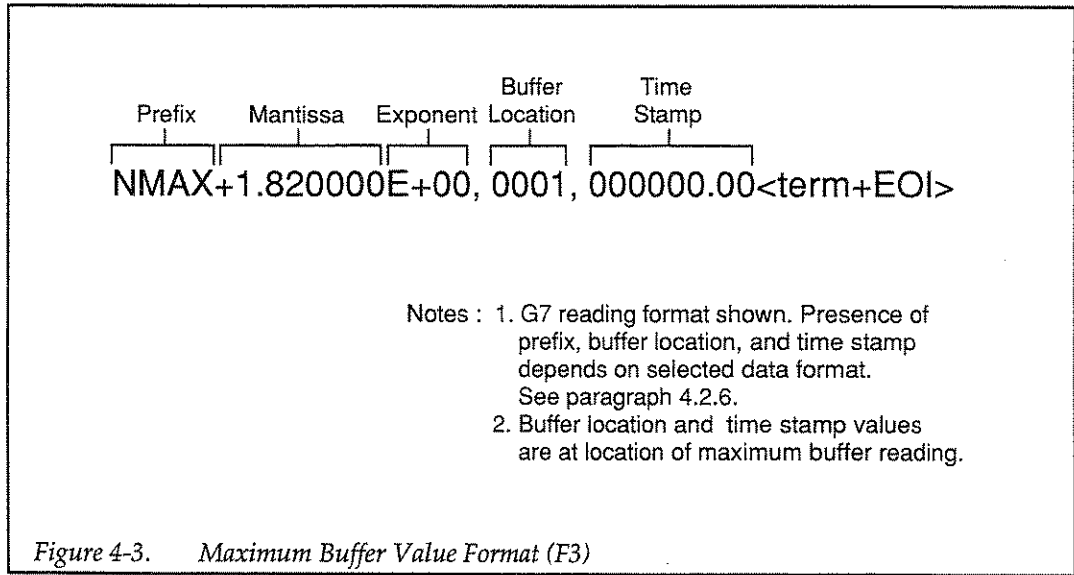

4.2.6 **G — Reading Format**

Purpose To control the prefix, buffer location, and time stamp information the instrument sends with each reading

Format **Gn**

Parameters

G0	Reading only
G1	Reading with prefix
G2	Reading with buffer location
G3	Reading with buffer location and prefix
G4	Reading with time stamp
G5	Reading with time stamp and prefix
G6	Reading with time stamp and buffer location
G7	Reading with time stamp, buffer location, and prefix

Default Upon power-up, or after receiving a DCL, SDC, or L1X or L2X command, the instrument returns to the factory default, which is reading with prefix (G1).

Description The G command allows you to control whether or not the instrument sends prefix, buffer location, and time stamp information with each reading. The general format for each reading is shown in Figure 4-5. Note that the prefix contains information about zeroed and overflowed readings.

Programming Notes

1. Buffer location and time stamp information will be available only if the buffer is enabled (I command, paragraph 4.2.8) and if the buffer is selected as the data source (F command, paragraph 4.2.5).
2. The range of buffer location values is between 1 and 1024.
3. The range of time stamp values is between 1msec and 999,999.999sec with 1msec resolution. The time stamp is the total elapse time from the initial trigger stimulus that stored the first reading after the buffer was enabled.
4. When accessing normal readings (F0), the buffer location will always be equal to 0000, and the time stamp value will always be set to 000000.000sec.
5. The data format can be changed at any time during buffer access. The newly-programmed data format will be placed into effect the next time the instrument is addressed to talk.
6. The reading field will appear as follows when an overflow condition occurs:
+9.999999E+95

Programming Examples

```

10 REMOTE 707           ! Put 182 in remote.
20 DIM R$(100)         ! Dimension reading string.
30 OUTPUT 707;"I1,10X" ! Enable buffer, 10 readings.
40 OUTPUT 707;"F1X"    ! Reading source is buffer.
50 FOR I = 0 TO 7      ! Loop for all formats.
60 OUTPUT 707;"G";I;"X" ! Program format.
70 ENTER 707;R$       ! Input reading string.
80 PRINT R$           ! Display reading string.
90 NEXT I              ! Loop back for next format.
100 END

```

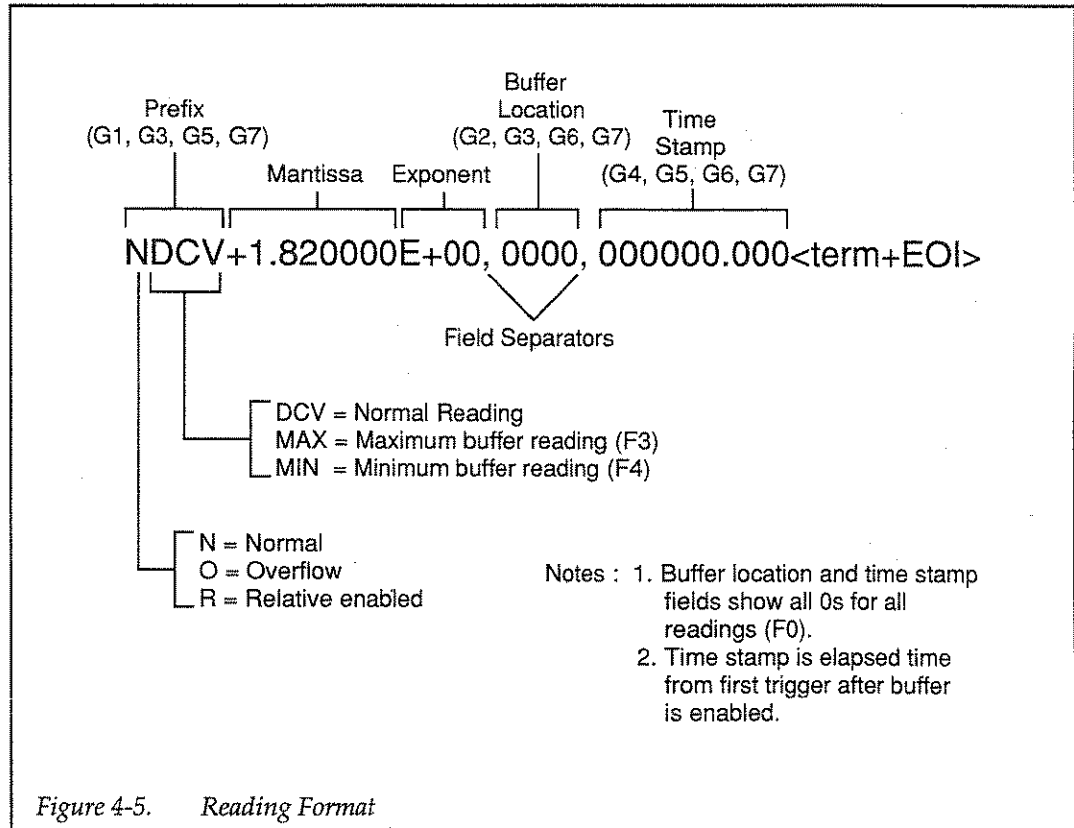

Figure 4-5. Reading Format

4.2.7 H — Manual Trigger and Memory Test

Purpose To immediately trigger the instrument, and to test internal memory circuits

Format Hn

Parameters

H0	Initiate manual trigger
H1	Perform memory test

Description The H0 command triggers one or more instrument readings and works regardless of the programmed trigger mode and source (paragraph 4.2.19). Thus, the H0 command performs essentially the same operation as the front panel MANUAL key.

The H1 command performs a test on internal RAM and NVRAM circuits. You can check the results of the self-test by noting the status of the RAM error bits in the U1 status word. (paragraph 4.2.20).

Programming Notes

1. The instrument holds off bus operation with the NRFD line during self-test operation. Thus, no commands can be sent during the self-test if hold-off on X is enabled.
2. The H0 command will not trigger instrument readings if triggers have been disabled with the T10 command.

Programming Examples

10	OUTPUT 707;"H0X"	! Perform manual trigger.
20	OUTPUT 707;"H1X"	! Perform memory test.

4.2.8 I — Buffer Configuration

Purpose To enable and disable the buffer, and to program linear and circular buffer operation

Format In or In,value

Parameters

I0	Disable Buffer
I1,value	Enable linear buffer, length=value
I2	Enable circular buffer, length=1024 readings

Default Upon power-up, or after the instrument receives a DCL, SDC or L1X or L2X command, the buffer will be disabled (I0).

Description The I command controls the 1024-reading buffer in a manner similar to the front panel STORE key. I1,value programs a linear buffer with the length equal to value. The maximum buffer length is 1024 readings. With a linear buffer, the instrument stores the programmed number of readings and then stops, saving stored readings until a new I command is issued.

The I2 command enables circular buffer operation, in which case the instrument will store 1024 readings and circulate back and overwrite old readings without stopping.

Various buffer operation modes are further discussed below.

Normal Operation, Readings from A/D Converter (F0 Mode)

Reading Available: A reading will be sent to the controller after the Model 182 has been addressed to talk. A reading will be sent only once per talk command.

Reading Unavailable: The bus will be held off until a new reading is available. Note that a bus hold-off may cause controller timeouts.

Time Stamp: The time stamp will always be set to 000000.000sec.

Location: The location will always be equal to 0000.

Linear Buffer Operation

The buffer characteristics outlined below apply to both single-reading (F1) and full-buffer access (F2), except as noted.

Triggering: Readings will be taken under specified trigger conditions and stored in the buffer as they become available. Once the buffer is full, storage will stop; readings will continue to be processed and displayed, but they will not be stored in the buffer.

Reading Available, Single-Reading Access (F1 Mode): A buffer reading is sent after the instrument is addressed to talk. Each reading is sent only once. After a reading has been sent, the buffer pointer will increment to the next buffer location so that each location may be read in succession. Once the last reading in the buffer has been accessed, the buffer pointer will reset to the first buffer location, allowing the buffer contents to be reread.

Reading Available, Full Buffer Access (F2 Mode): The full buffer contents will be sent when the Model 182 is addressed to talk. The buffer can be reread as many times as desired.

Reading Unavailable, Single-Reading Access (F1 Mode): The bus will be held off until a reading has been stored at the current buffer pointer location. This situation could occur if you attempt to access buffer data at a rate faster than the instrument is storing data. Note that a bus hold-off may cause a controller timeout.

Reading Unavailable, Full Buffer Access (F2 Mode): If the Model 182 is addressed to talk when the buffer is not full, the available buffer contents are sent. The bus will be held off until each subsequent reading becomes available until the buffer is full. Note that controller timeouts may occur in this situation.

Buffer Full SRQ: Set when the buffer is full, cleared when the buffer is first enabled with I1. A full buffer is defined as the value programmed with the I1 command, not necessarily the full, 1024-reading possible length.

Buffer Half-Full SRQ: Set when the buffer becomes half full, cleared when the buffer is first enabled with the I1 command. The half-full point depends on the size programmed with the I1 command. In the case of an odd-numbered buffer length, a half-full condition occurs when the number of stored readings reaches $(\text{size}/2 + 1)$.

Time Stamp: The unit will send the actual time stamp value, referenced to the time when the first buffer reading was taken.

Location: The location will increment from 1 to 1024 (or 1 to programmed buffer length). Location 1 is sent first and contains the oldest reading stored in the buffer.

Circular Buffer Operation

The characteristics discussed below apply to both single-reading (F1) and full-buffer (F2) reading access.

Triggering: Readings will be taken under specified trigger conditions and stored in the buffer from lowest to highest location as they become available. Once the buffer is full (1024 readings

taken), the buffer will wrap around to the first location and store (and display) new readings. Old readings previously stored in the buffer will be overwritten as new readings become available.

Reading Available: When the instrument is addressed to talk, the buffer is turned off, and a reading is sent. The buffer pointer will then decrement to the previous buffer location. No further readings will be stored once the buffer has been turned off until an I1 or I2 command is reissued.

Reading Unavailable: If the buffer is empty when the instrument is addressed to talk, the buffer will not turn off until one reading is taken. This reading will then be sent over the bus. Note that this situation may result in a controller timeout.

Buffer Full SRQ: Set when the buffer wraps around the first time, cleared when the buffer is first enabled with the I command.

Buffer Half-full SRQ: No buffer half-full SRQ will occur because, by definition, the buffer is never half-full when in circular mode.

Time Stamp: Actual time stamp value referenced to the time when the first reading was stored.

Location: Readings are sent in the most-recent to oldest order. As a result, the location of the first reading sent will be 1024 (if the buffer has wrapped around at least once), or most recently acquired reading (if the buffer has not wrapped around). Subsequent readings will be sent in newest-to-oldest order until location 1 is sent, after which the buffer output pointer will be reset to the most recent reading location, allowing the buffer contents to be reread.

Programming Notes

1. The F command controls the source of the readings which the instrument sends over the bus. See paragraph 4.2.5.
2. In addition to buffer readings, available buffer information includes time stamp and buffer location values. These parameters can be programmed using the G command (paragraph 4.2.6).
3. In the multiple trigger mode, the programmed trigger interval determines the rate at which buffer readings are stored (paragraph 4.2.16).
4. In the one-shot trigger mode, each buffer reading to be stored must be separately triggered. The trigger stimulus required depends on the programmed trigger source (paragraph 4.2.19).
5. Sending either the I1 or I2 command to enable the buffer will clear the buffer of any previously-stored readings.
6. The instrument can be programmed to generate an SRQ (service request) when the buffer is full or half full. In addition, two bits in the status byte flag buffer-full and buffer-half-full status. See paragraph 4.2.12.
7. The reading format, which is set by the G command (paragraph 4.2.6), can be changed at any time during buffer operation. The newly-programmed format will take effect with the next talk operation.

8. The buffer pointer will be reset by the DCL, SDC, and IFC commands.
9. Terminating a talk operation will not reset the buffer pointer; it will, however, abort the current talk operation in progress.

Programming Examples

```
10 REMOTE 707           ! Put 182 in remote.
20 DIM R$(100)         ! Dimension reading string.
30 OUTPUT 707;"M4X"    ! SRQ on buffer full.
40 OUTPUT 707;"I1,100X" ! Enable buffer,100 readings.
50 PRINT "Filling buffer..."
60 STATUS 7,7;S       ! Get bus status.
70 IF NOT BIT(S,10) THEN 60 ! Wait for SRQ.
80 S=SPOLL(707)       ! Clear SRQ.
90 OUTPUT 707;"F1X"   ! Reading source is buffer.
100 OUTPUT 707;"G7X"  ! Prefix,location,time stamp.
110 FOR I=1 TO 100    ! Loop for all locations.
120 ENTER 707;R$      ! Get buffer reading.
130 PRINT R$          ! Display buffer reading.
140 NEXT I            ! Loop back for next reading.
150 END
```

4.2.9 J — Analog Output Relative

Purpose To enable and disable analog output relative, and to program the analog output relative value

Format Jn or Jn,value

Parameters

J0	Disable analog output relative
J1	Enable analog output relative using next output value as relative value
J2,value	Enable analog output relative using value ($\pm 1E-9$ to ± 30.3)
J3	Enable analog output relative using previous output relative value

Default Upon power-up, or after receiving a DCL, SDC, or L2X command, the instrument returns to the programmed default. Factory default is analog output relative disabled (J0).

Description The J command controls the analog output relative in a manner similar to the front panel REL OUTPUT key. Sending J1 enables analog output relative, and the instrument will store the next analog output value as the analog output relative value. J2,value allows you to program the analog output relative value directly. Note that the analog output relative value is specified in volts. The J3 command enables analog output relative using the previous analog output relative value whether that value was obtained using J1 or J2.

Additional information on using the analog output is located in paragraph 3.9.

Programming Note In the one-shot trigger mode, the instrument must be triggered with the appropriate trigger stimulus after enabling analog output relative before it will store the relative value.

Programming Examples

10	OUTPUT 707;"J1X"	! Enable output relative.
20	OUTPUT 707;"J2,2X"	! Output relative = 2.
30	OUTPUT 707;"J0X"	! Disable output relative.
40	OUTPUT 707;"J3X"	! Enable relative using former relative value.

4.2.10 K — EOI and Bus Hold-Off

Purpose To enable/disable EOI and bus hold-off on X

Format Kn

Parameters

K0	Enable EOI, Enable bus hold-off on X
K1	Disable EOI, Enable bus hold-off on X
K2	Enable EOI, Disable bus hold-off on X
K3	Disable EOI, Disable bus hold-off on X

Default Upon power-up, or after receiving a DCL, SDC, L1X, or L2X command, the instrument returns to the factory default K0 (both EOI and bus hold-off on X enabled).

Description The EOI line provides one method to positively identify the last byte in the data string sent by the instrument. When enabled, EOI is asserted with the last byte the instrument sends over the bus.

Bus hold-off allows the instrument to temporarily hold up bus operation via the NRFD line when it receives the X character until all commands are processed.

Programming Notes

1. Some controllers rely on EOI to terminate their input sequences. Turning off EOI may cause the controller input sequence to hang up.
2. When enabled, EOI is asserted with the last byte in the terminator.
3. When bus hold-off is enabled, all bus activity is held up for the duration of the hold-off period — not just the activity associated with the Model 182.

Programming Examples

10	OUTPUT 707;"K1X"	! No EOI, hold-off on X.
20	OUTPUT 707;"K2X"	! Send EOI with last byte, do not hold-off on X.

4.2.11 L — Save/Recall Configuration

Purpose To save a user-defined instrument configuration, and to recall factory default or user configuration

Format Ln

Parameters

L0	Save present configuration as power-up setup
L1	Restore factory default conditions
L2	Recall user configuration stored with L0 command

Factory Default Command	Description
B1	6 1/2-digit display resolution
J0	Analog output disabled N1 Filters on
O0	Analog filter disabled
P2	Medium response digital filter
Q0	Default trigger interval (250msec)
R5	30V range
S0	Line cycle integration period
T6	Multiple on external trigger
V0,1	Analog output source= meter, gain =1
W0	Trigger delay disabled
Z0	Reading relative disabled

In addition, the following parameters are saved and recalled:

Parameter	Factory Default
Analog output relative value	0V
Analog output gain	1.0
Analog output source value	0V
Reading relative value	0V

Description The L0 command allows you to store the desired instrument configuration as power-on default. L1 recalls the factory default instrument configuration, which is summarized in the tables above. L2 allows you to restore the configuration that was stored using the L0 command. The L2 configuration is the same as the default power-on and DCL/SDC configuration.

Programming Notes

1. The L command does not affect the programmed primary address.
2. The instrument will not process commands during the few seconds it takes to save or recall a setup. The bus will be held off during this period if NRFD hold-off is enabled.
3. Commands which pertain exclusively to bus operation (such as Y, K, F, M, and G) are not saved by the L command. L1 or L2 will recall factory defaults for these bus-only commands.

Programming Examples

10	OUTPUT 707;"L0X"	! Save current setup.
20	OUTPUT 707;"L1X"	! Restore factory setup.
30	OUTPUT 707;"L2X"	! Recall user setup.

4.2.12 **M — SRQ Mask and Status Byte Format**

Purpose To program which conditions generate an SRQ (service request)

Format Mn

Parameters

M0	SRQ disabled
M1	Reading done
M2	Buffer half full
M4	Buffer full
M8	Reading overflow
M16	Ready for command
M32	Error
M128	Ready for trigger

Default Upon power-up, or after receiving a DCL, SDC, or L1X or L2X command, the instrument returns to the factory default, which is M0 (SRQ disabled). NOTE: After power-up or a DCL or SDC, all serial poll status byte bits, the SRQ annunciator, and the bus SRQ line will be cleared.

Description The SRQ command selects which conditions cause the Model 182 to generate a service request via the bus SRQ line. Bits in the status byte will always be updated as events occur. Whether or not the unit generates an SRQ for a given status byte condition depends on the condition of the corresponding SRQ mask byte at the time the condition occurred. (Setting the mask bit of an event that has already occurred but has not been cleared will not generate an SRQ.)

An 8-bit SRQ mask determines which conditions cause an SRQ to be generated. (See Figure 4-6.) By sending the appropriate M command along with the desired command options, you can set the bit or bits to enable SRQ generation if those particular conditions occur.

Status Byte

The general format of the status byte is shown in Figure 4-6. Note that all bits except for bit 6 correspond to the bits in the SRQ mask. These bits are set and cleared under the following conditions:

Bit	Set by	Cleared by
7	Ready for trigger	Triggering unit
6	SRQ by 182	Reading status byte
5	U1 error	Reading U1 status
4	Ready for command	Processing command
3	Reading overflow	Removing overflow condition
2	Buffer full	Reinitializing buffer
1	Buffer at least half full	Reinitializing buffer
0	Reading done	Reading the conversion from the A/D converter (F0), or by changing the trigger mode from multiple to one-shot.

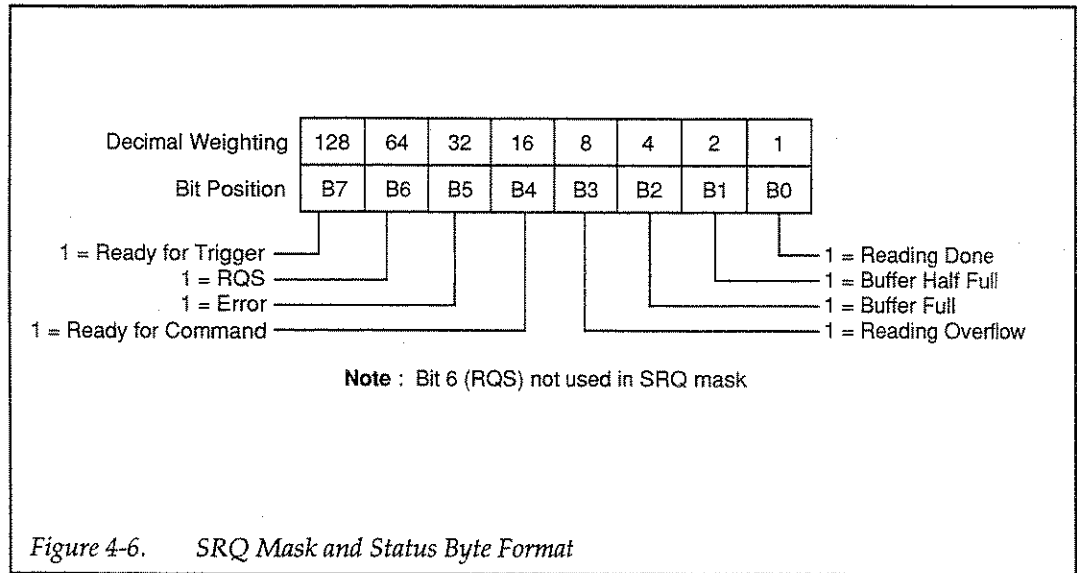

Programming Notes

SRQ Mask

1. The instrument may be programmed to generate an SRQ for more than one set of conditions simultaneously. To do so, simply add up the decimal bit values for the required SRQ conditions. For example, to enable SRQ under reading done (M1) and U1 error conditions (M32), send M33X.
2. The front panel SRQ annunciator will turn on when the instrument generates an SRQ. The SRQ indicator will turn off when the SRQ condition is cleared.
3. An SRQ will be generated only if the corresponding bit(s) in the SRQ mask were already set at the time the condition first occurred. Setting a mask bit for a condition that has already occurred (and has not been reset) will not generate an SRQ.

Status Byte

1. If an error occurs, bit 5 (error) in the status byte latches and remains latched until the U1 word is read (paragraph 4.2.20). The U1 error status word defines the nature of the error.
2. The status byte should be read to clear the SRQ line once the instrument has generated an SRQ. Bit 6 (RQS) is cleared when the status byte is read.
3. Even with SRQ disabled, the status byte can be read to determine corresponding instrument conditions.
4. The reading overflow bit will not be set during auto-ranging activity.
5. The defined buffer full and buffer half full conditions depend on the programmed buffer length (paragraph 4.2.8). For example, if the buffer has a programmed length of 100 readings, buffer half full is defined as being at least 50 readings, and buffer full is 100 readings.

**Programming
Examples**

```
10 DIM Err$(50)           ! Dimension string for error
20 REMOTE 707             ! Put 182 in remote
30 OUTPUT 707;"M32X"     ! Program for SRQ on error
40 OUTPUT 707;"E1X"     ! Program invalid command
50 S=SPOLL (707)         ! Serial poll the 182
60 IF NOT BIT(S,5) THEN 50 ! Wait for SRQ to occur
70 PRINT "B7 B6 B5 B4 B3 B2
   B1 B0"                ! Label the bit positions
80 FOR I=7 TO 0 STEP -1  ! Loop eight times
90 PRINT BIT(S,I);       ! Print the bit positions
100 NEXT I
110 PRINT
120 OUTPUT 707;"U1X"     ! Request U1 error word
130 ENTER 707;Err$
140 PRINT Err$
150 END
```

4.2.13

N — Enable/Disable Filters

Purpose To enable and disable the analog and digital filters

Format Nn

Parameters N0 Disable filters
N1 Enable filters

Default Upon power-up, or after receiving a DCL, SDC, or L2X command, the instrument returns to the power-on programmed default. The factory default is N1 (filters enabled).

Description The N command enables and disables both the analog and digital filters if those filters are configured to be enabled by their respective commands. The O command controls the analog filter configuration (paragraph 4.2.14), and the P command controls the digital filter response (paragraph 4.2.15). The N command performs the same operation as the front panel FILTER key.

Programming Examples

10	OUTPUT 707;"N1X"	! Enable filters
20	OUTPUT 707;"N0X"	! Disable filters

4.2.14 O — Analog Filter Configuration

Purpose To control analog filter configuration when filters are enabled

Format On

Parameters O0 Configure analog filter off
O1 Configure analog filter on

Default Upon power-up, or after receiving a DCL, SDC, or L2X command, the instrument returns to the power-on programmed default. The factory default is O0 (analog filter off).

Description The O command controls the configuration the analog filter will assume when filters are turned on with the N1 command. The analog filter should be turned on for maximum normal mode noise rejection, and it should be turned off for shortest settling times. Refer to paragraph 3.7 for more information on the analog filter.

Programming Examples

10	OUTPUT 707;"O1X"	! Analog filter on
20	OUTPUT 707;"O0X"	! Analog filter off

4.2.15 P — Digital Filter Configuration

Purpose To control the digital filter state and response

Format Pn

Parameters

P0	Configure digital filter off
P1	Configure fast response
P2	Configure medium response
P3	Configure slow response

Default Upon power-up, or after receiving a DCL, SDC, or L2X command, the instrument returns to the programmed power-up default. The factory default is P2 (medium response).

Description The P command controls the response of the 3-pole digital filter when filters are enabled with the N1 command. With P0, the digital filter is completely disabled. P1 provides fast response filtering, which is the minimum digital filtering available. At the opposite extreme, P3 gives slow response filtering without a window. Detailed information on digital filter characteristics is located in paragraph 3.7.

Programming Notes

1. Using the digital filter will affect the reading settling time and may reduce the overall reading rate.
2. Using the Model 182 with the digital filter disabled may result in excessively noisy readings, especially on the lower measurement ranges.
3. Both the digital and analog filters are turned on and off with the N command (paragraph 4.2.13).

Programming Examples

10 OUTPUT 707;"P2X"	! Medium response filter.
20 OUTPUT 707;"P3X"	! Slow response filter.
30 OUTPUT 707;"P0X"	! Disable digital filter.

4.2.16 Q — Trigger Interval

Purpose To program the time interval between readings in the multiple trigger mode

Format Qvalue

Parameters Qvalue Value = interval (10-999 999msec)

Default Upon power-up, or after receiving a DCL, SDC, or L2X command, the instrument returns to the programmed default. Factory default is Q250 (250msec interval).

Description The Q command sets the trigger interval of the instrument where Qvalue sets the interval in msec. The minimum interval value is 10msec, and the maximum interval value is 999 999msec.

Programming Notes

1. The trigger interval applies only when the instrument is in the multiple trigger mode; it does not apply in the one-shot trigger mode (paragraph 4.2.19).
2. The programmed trigger interval affects the interval at which the instrument stores buffer readings when the buffer is enabled (paragraph 4.2.8).
3. Setting the trigger interval too short for the programmed integration period will result in the instrument using the shortest interval it can under the current configuration. The programmed trigger interval will be retained and may be achieved if the configuration later changes.

Programming Examples

10	OUTPUT 707;"Q0X"	! Program default interval.
20	OUTPUT 707;"Q1000X"	! Select 1sec interval.
30	OUTPUT 707;"Q200X"	! Program 200msec interval.

4.2.17 R — Range

Purpose To program the measurement range

Format Rn

Parameters	R0	Enable auto-range
	R1	3mV range
	R2	30mV range
	R3	300mV range
	R4	3V range
	R5	30V range
	R6	No function
	R7	No function
	R8	Disable auto-range

Default Upon power-up, or after receiving a DCL, SDC, or L2X command, the instrument returns to the programmed power-up default conditions. The factory default is R5 (30V range).

Description The R command controls the instrument's manual range and also allows you to control auto-ranging, combining the functions of the front panel RANGE UP, DOWN, and AUTO keys. When using manual ranging, you should choose the lowest range possible without overflowing the instrument for best accuracy and resolution.

Programming Notes

1. Choosing a manual range too low for the applied signal cause an overflow condition. The instrument can be programmed to generate an SRQ if an overflow condition occurs (paragraph 4.2.12).
2. R6 and R7 are effectively no-operation commands, which are included for compatibility with the Model 181 Nanovoltmeter. Sending R6 or R7 will not generate an INVALID OPTION error.
3. When auto-range is disabled using the R8 command, the instrument will stay on the present range.

Programming Examples	10 OUTPUT 707;"R2X"	! Program 30mV range.
	20 OUTPUT 707;"R1X"	! Program 3mV range.
	30 OUTPUT 707;"R0X"	! Enable auto-range.
	40 OUTPUT 707;"R8X"	! Disable auto-range.

4.2.18 S — Integration Period

Purpose To set the integration period of the A/D converter

Format Sn

Parameters

S0	Line cycle integration
S1	3msec integration period
S2	100msec integration period

Default Upon power-up, or after receiving a DCL, SDC, or L2X command, the instrument returns to the programmed power-up conditions. The factory default is S0 (line cycle integration).

Description The S command sets the integration period of the A/D converter. Available periods are line cycle, 3msec, and 100msec. With line cycle, the period is 20msec when the instrument is operated from 50Hz power sources, and the period is 16.67msec when the instrument is operated from 60Hz power sources.

Programming Notes

1. The programmed integration period affects the usable resolution and noise. For maximum resolution and minimum noise, use 100msec integration. To obtain the fastest reading rates with short trigger intervals, use a 3msec integration period (noise will increase, and usable resolution will decrease, however).
2. The power line frequency, which determines the integration period for line-cycle integration, is automatically detected by the instrument on power-up; no user programming is necessary to set the line frequency.
3. Selecting an integration period too long for the programmed trigger interval will result in the instrument's using the shortest possible trigger interval under the current instrument configuration.

Programming Examples

10	OUTPUT 707;"S0X"	! Select line cycle period.
20	OUTPUT 707;"S1X"	! Select 3msec period.
30	OUTPUT 707;"S2X"	! Select 100msec period.

4.2.19

T — Trigger Mode and Source

Purpose To program the trigger source and mode

Format Tn

Parameters

T0	Multiple on talk
T1	One-shot on talk
T2	Multiple on GET
T3	One-shot on GET
T4	Multiple on X
T5	One-shot on X
T6	Multiple on external
T7	One-shot on external
T8	Multiple on manual
T9	One-shot on manual
T10	Disable all triggers

Default Upon power-up, or after receiving a DCL, SDC, or L2X command, the instrument returns to the programmed power-up configuration. Factory default trigger mode and source is T6 (multiple on external).

Description The T command controls both the trigger mode and the trigger source. The two trigger modes are multiple and one-shot. In the multiple mode, the instrument processes an unending series of readings at the interval specified with the Q command without requiring a trigger for each reading. In one-shot, however, a separate trigger is required for the instrument to process each reading. The trigger stimulus depends on which of the following trigger sources is programmed:

Talk	The IEEE-488 bus talk command provides the trigger
GET	The multiline GET command triggers the unit
X	The X (execute) command triggers the Model 182
External	A trigger pulse applied to the rear panel EXTERNAL TRIGGER INPUT provides the trigger
Manual	Pressing the front panel MANUAL key triggers the unit

Programming Notes

1. The talk command trigger value must correspond to the programmed primary address. For example, with the default primary address of 7, the correct talk command byte is 47H.
2. Paragraph 3.6 covers triggering in detail.
3. After changing from a one-shot trigger mode to a multiple trigger mode, you must supply the appropriate trigger stimulus before the instrument will begin processing readings.
4. The instrument can also be triggered with the H0 command (or by pressing MANUAL while in local) regardless of the programmed trigger source unless triggers are disabled.

Programming Examples

10 OUTPUT 707;"T1X	! One-shot on talk.
20 OUTPUT 707;"T3X"	! One-shot on GET.
30 OUTPUT 707;"T8X"	! Multiple on manual.

4.2.20 U — Alternate Output

Purpose To obtain various instrument status words

Format Un

Parameters	U0	Send machine status
	U1	Send error status
	U2	Send firmware revision
	U3	Send buffer length
	U4	Send buffer average
	U5	Send buffer standard deviation
	U6	Send reading relative value
	U7	Send analog output relative value
	U8	Send analog output gain value
	U9	Send trigger interval
	U10	Send trigger delay value
	U11	Send calibration constants
	U12	Send calibration lock status
	U13	Send Model 181-like status
	U14	Send ASCII text string

Description By sending the appropriate U command and then addressing the instrument to talk as with default output, you can obtain information on machine status, error conditions, and other information on the buffer, relative and gain values, and calibration information. The information is transmitted only once each time after the U command is received by the instrument.

U0 — Machine Status Word

The format of the U0 machine status word is shown in Figure 4-7. After the 182 identifier, the letters correspond to the modes programmed by the respective device-dependent commands.

U1 — Error Status Word

The U1 command allows access to the error status words, which contains information on Model 182 error conditions. The error status word (Figure 4-8) is actually a string of ASCII characters representing binary bit positions. A value of 1 in a given position indicates that the condition occurred, while a value of 0 in a given position indicates that the condition did not occur.

Reading the U1 status clears any latched bits. An error condition is flagged in the status byte, and the instrument can be programmed to generate an SRQ when an error occurs (see paragraph 4.2.12).

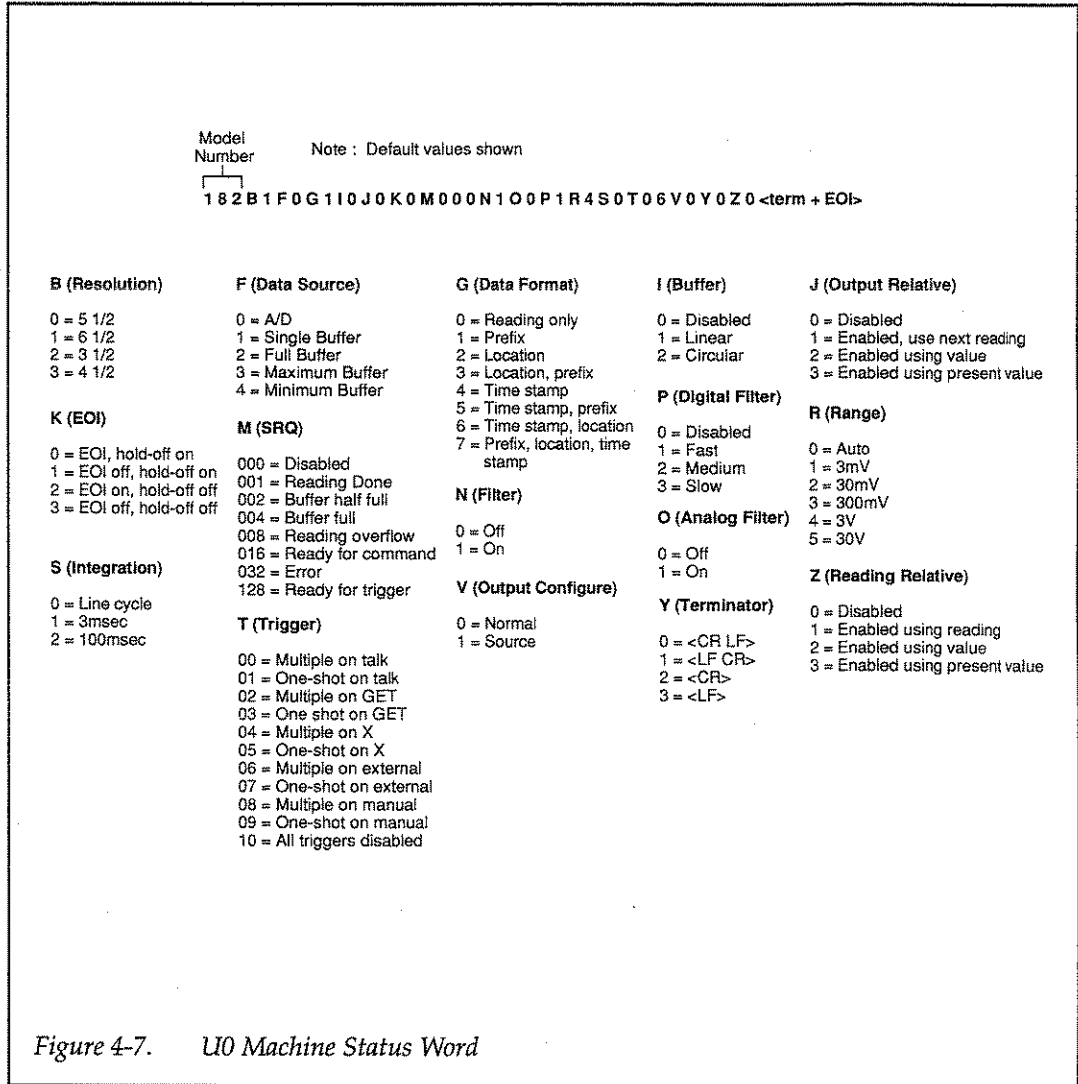

NVRAM Error (bit 6): An error condition in the NVRAM was detected during the self-test.

RAM Error (bit 7): An error condition in RAM was detected during the self-test.

Uncalibrated Error (bit 8): Upon power-up, the calibration constants were found to be corrupted, or the unit was never properly calibrated.

Cal Running Error (bit 9): The unit received an invalid command while in the calibration mode. Valid commands which can be sent during calibration include:

- SRQ mask (M)
- Range, except auto-range (R)
- Calibration (C)
- Display (A)
- Reading format (G)
- Terminators (Y)
- EOI and hold-off (K)
- Alternate output (U)

Cal Locked Error (bit 10): Unit received a calibration command with calibration locked.

Cal Error (bit 11): Unit received calibration value outside the allowed range for the applied calibration signal.

Reserved bits (12 and 13): These bits are reserved for future expansion.

A/D Com Error (bit 14): A communication error was detected with the A/D converter microcontroller.

Front Panel Failure (bit 15): A communication error was detected with the front panel microcontroller.

Trigger Not Ready (bit 16): The unit received a trigger, but the instrument is still processing the previous trigger.

Reserved (bits 17-20): These bits are reserved for future expansion.

U2 — Firmware Revision

The response to a U2 command is a string denoting the instrument firmware revision level for all three processors, as shown in Figure 4-9.

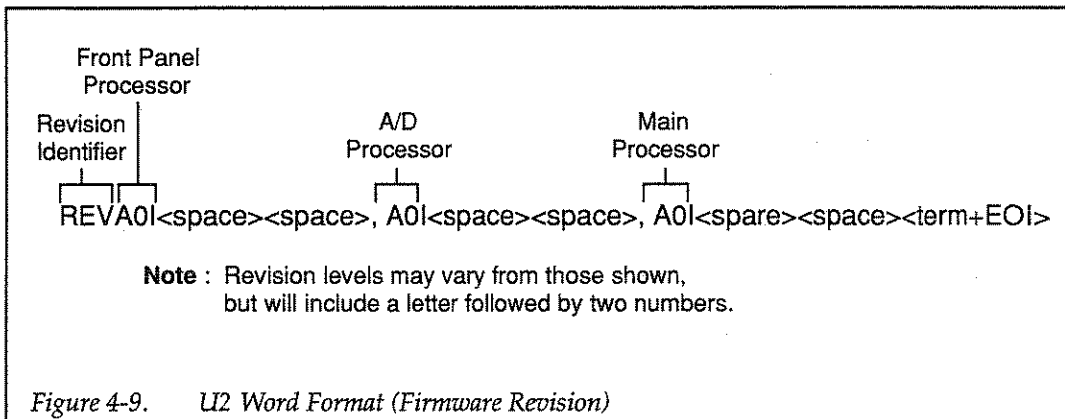

For example, a firmware revision level of A01 for all three processors would be sent as follows:

182A01 ,A01 ,A01

The U2 word is sent with two trailing spaces after each revision level parameter plus the terminator and EOI at the end of the string (unless disabled with the K command).

U3-U5 — Buffer Information

The U3 through U6 commands return information on buffer length, average value, and standard deviation. The length is the programmed maximum length of the buffer.

Formats for these returned values are shown in Figures 4-10 through 4-12.

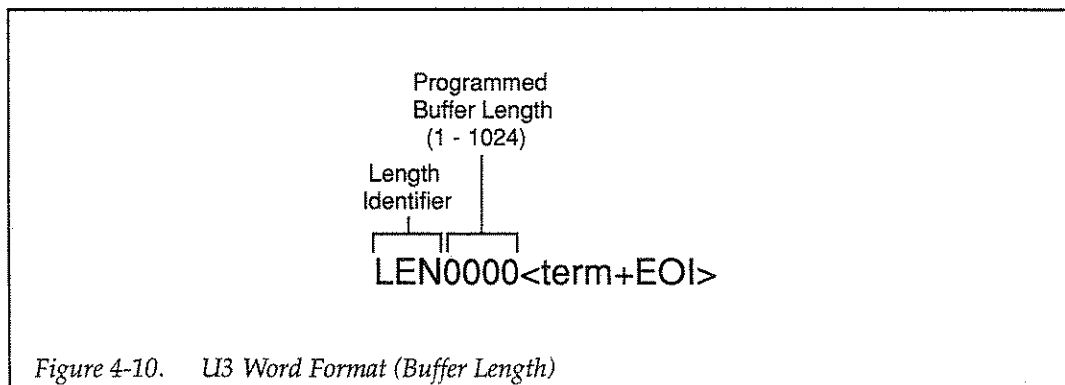

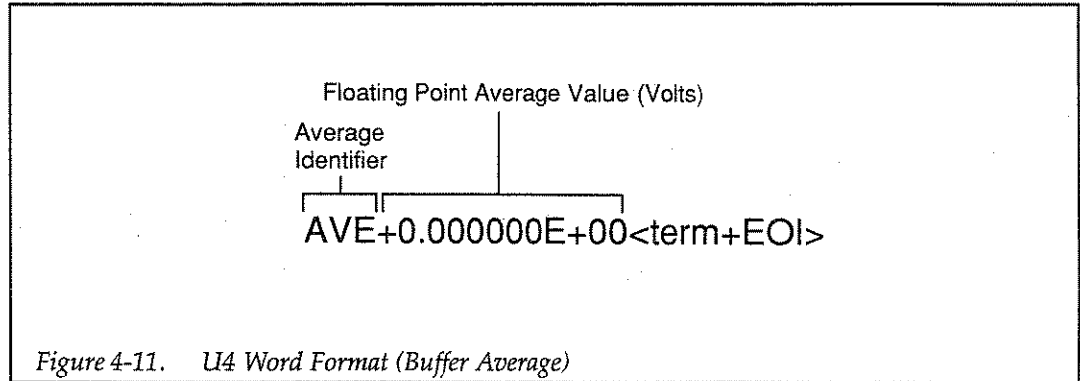

Figure 4-11. U4 Word Format (Buffer Average)

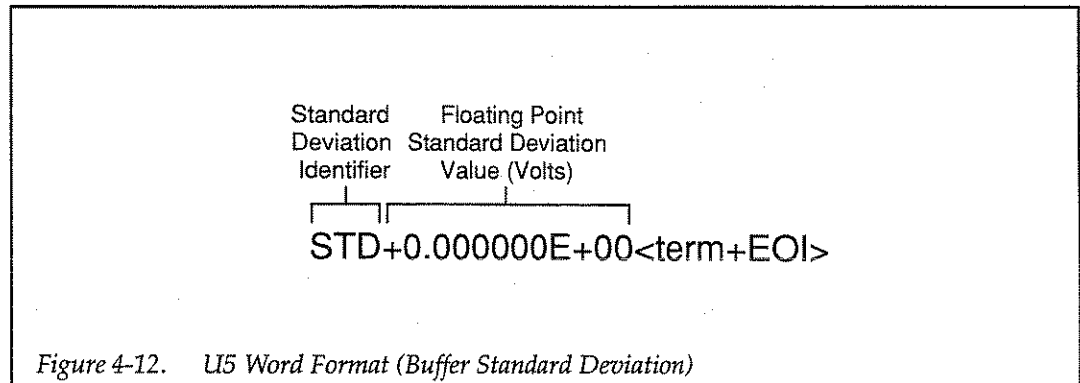

Figure 4-12. U5 Word Format (Buffer Standard Deviation)

U6-U8 — Relative and Gain Values

U6 returns the reading relative value and has the format shown in Figure 4-13. U7 and U8 return the analog output relative and gain values respectively; formats for these two status words are shown in Figures 4-14 and 4-15.

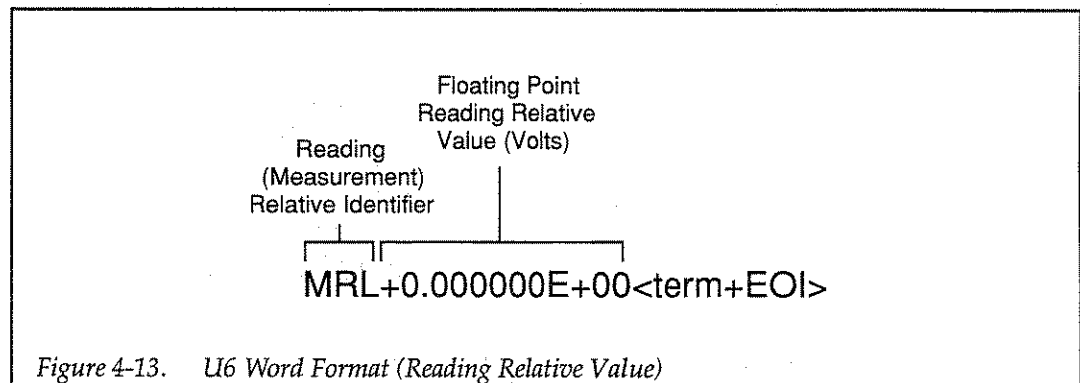

Figure 4-13. U6 Word Format (Reading Relative Value)

Output Relative Identifier	Floating Point Output Relative Value (Volts)
┌──────────┴──────────┐	
ORL+0.000000E+00<term+EOI>	

Figure 4-14. U7 Word Format (Analog Output Relative Value)

Output Gain Identifier	Floating Point Output Gain Value (Volts)
┌──────────┴──────────┐	
OGN+1.000000E+00<term+EOI>	

Figure 4-15. U8 Word format (Analog Output Gain)

U9 and U10 — Trigger Interval and Trigger Delay

U9 returns the programmed trigger interval with the format shown in Figure 4-16. U10 returns the trigger delay value and is shown in Figure 4-17.

Trigger Interval Identifier	Trigger Interval Value (msec)
┌──────────┴──────────┐	
INT000250<term+EOI>	

Figure 4-16. U9 Word Format (Trigger interval)

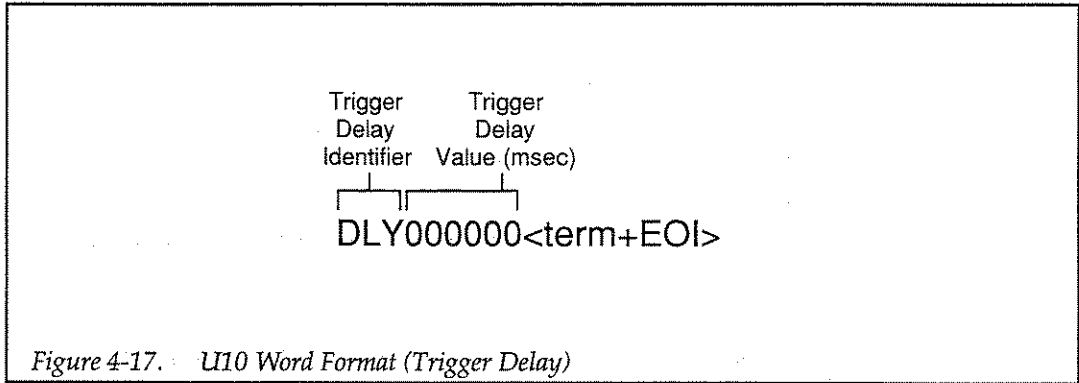
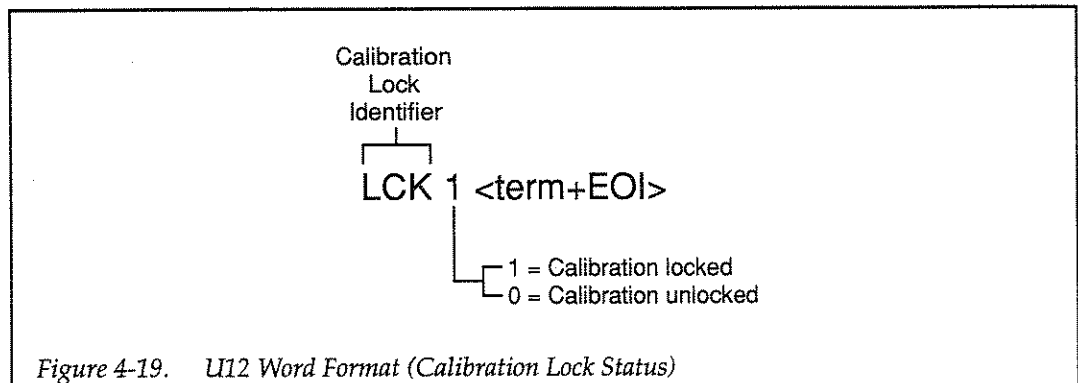
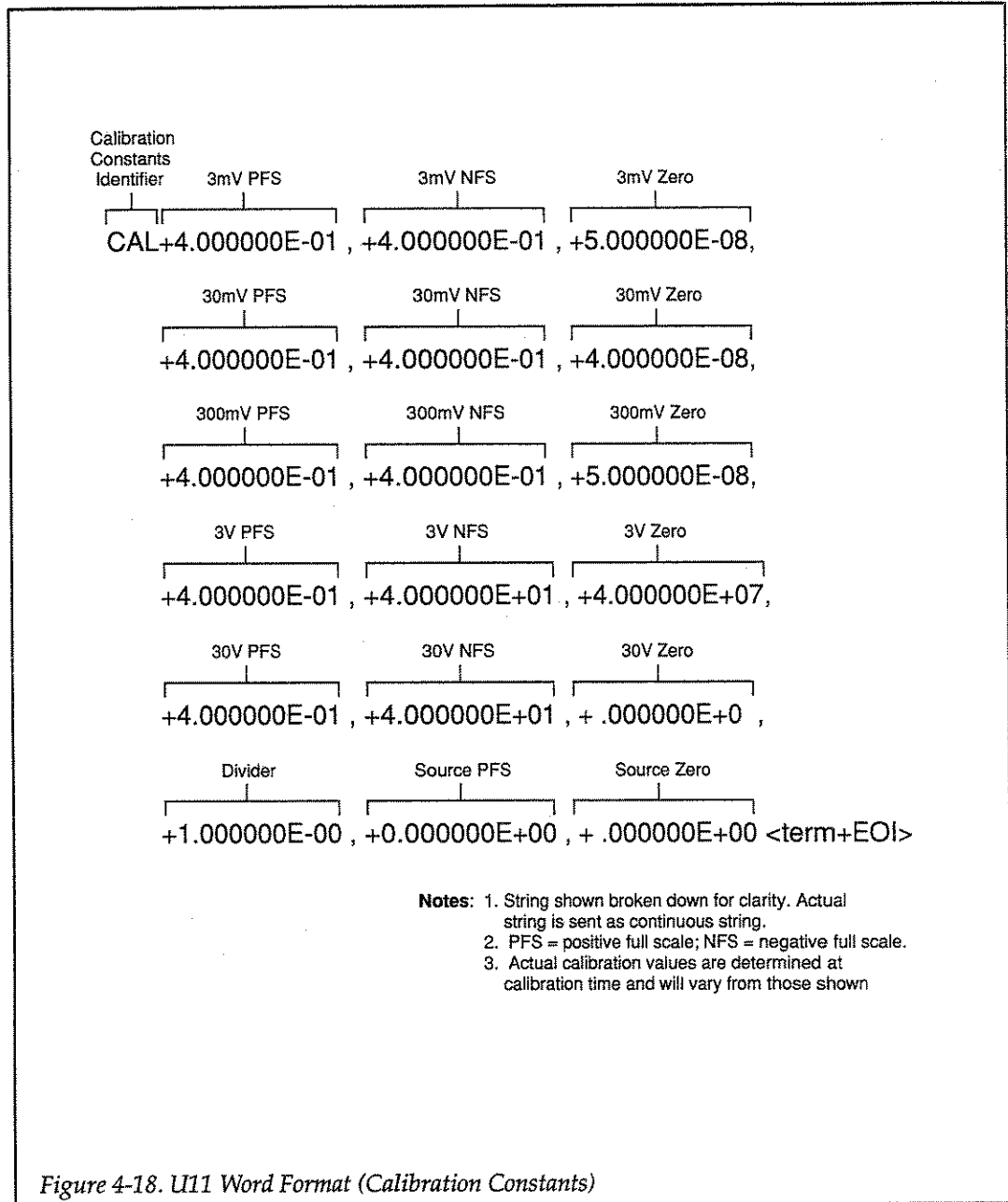

Figure 4-17. U10 Word Format (Trigger Delay)

U11 and U12 — Calibration

U11 returns the calibration constants with the format shown in Figure 4-18. U12 returns calibration lock status and is shown in Figure 4-19.



U13 — Model 181-Like Machine Status

U13 returns the machine status using Model 181 Nanovoltmeter format. This command is included for compatibility with the Model 181, and it has the format shown in Figure 4-20.

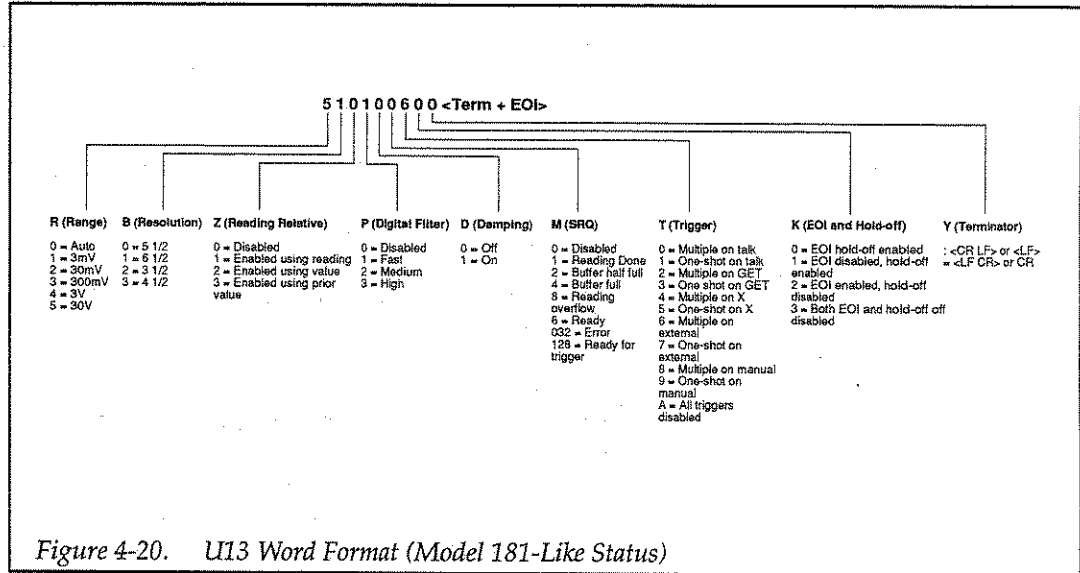

U14 — Stored ASCII Text String

The U14 command returns the ASCII text string which was stored in EEROM using the A2 command (paragraph 4.2.1). The general format of the U14 word is shown in Figure 4-21.

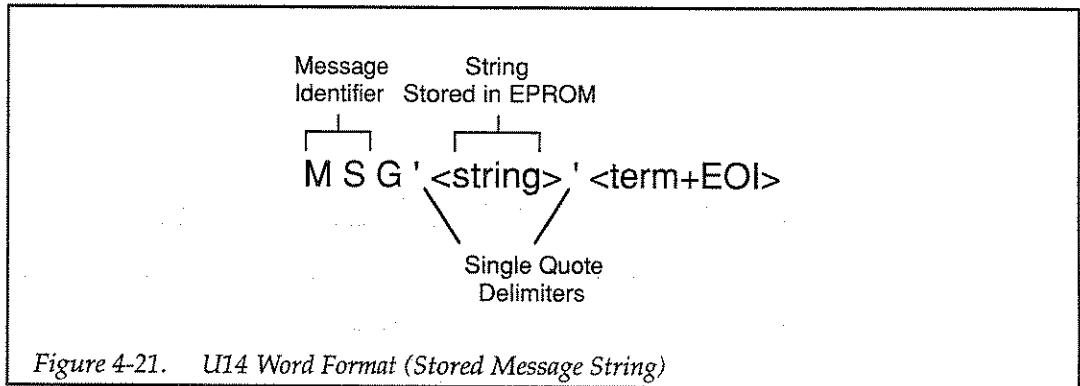

Programming Notes

1. The terminator sequence is sent at the end of the alternate output strings. The terminator is programmed with the Y command (paragraph 4.2.24). Default terminator is <CR><LF>.
2. EOI will be asserted with the last character of the alternate output sequence if enabled with the K command (paragraph 4.2.10). Default is EOI enabled.
3. <string> will always contain 49 characters. Unused positions will be padded with spaces.

Programming Examples

```

10 DIM St$(300)           ! Dimension status string
20 REMOTE 707             ! Put 182 in remote
30 FOR I= 0 TO 14        ! Loop for all status words.
40 OUTPUT 707;"U";I;"X" ! Program 182 with U command
50 ENTER 707;St$         ! Get U status
60 PRINT St$             ! Print U status
70 NEXT I                ! Loop back for next status
80 END

```

4.2.21 V — Analog Output Configuration, Gain, and Value

Purpose To program the analog output configuration (normal or source), and to program the gain and source value

Format Vn,m

Parameters V0,gain Normal mode, gain (.001–999 999.999)
V1,value Source mode, output=value (–3.3 to +3.3)

Default Upon power-up, or after receiving a DCL, SDC, or L2X command, the instrument returns to the programmed power-up default value. The factory default is V0,1 (normal, gain =1).

Description The V0,gain command selects the normal operating mode for the analog output. You can set the gain to .001 to 999 999.999 by including the gain parameter as required. The reading will be multiplied by this gain factor and by an internal gain factor that depends on the range (see paragraph 3.1).

V1,value sets the analog output for source operation and allows you to program the analog output voltage to the desired value in the range of –3.3V to +3.3V. This feature is convenient for testing the analog output. The resolution of the output value is 1mV.

Paragraph 3.9 covers analog output operation in detail.

Programming Note You must include both parameters when using the V command, even if one of the parameters is to be left unchanged.

Programming Examples

10	OUTPUT 707;"V0,100X"	! Normal mode,gain=100.
20	OUTPUT 707;"V1,2.5X"	! Source mode, value=2.5V.

4.2.22 W — Trigger Delay

Purpose To enable/disable the trigger delay, and to program the trigger delay period

Format Wn

Parameters
W0 Disabled trigger delay
Wvalue Enable delay, delay=value (1msec to 999999msec)

Default Upon power-up, or after receiving a DCL, SDC, or L2X command, the instrument returns to the programmed power-up condition. Factory default is W250 (250msec).

Description The W command controls the trigger delay period, which is the period from the time when the instrument is triggered to the time it starts the first A/D conversion in the reading. The trigger delay is intended to add a user-defined settling time.

Programming Note The trigger delay period is in effect only when the instrument is in the one-shot trigger mode.

Programming Examples
10 OUTPUT 707;"W1000X" ! Program 1sec trigger delay.
20 OUTPUT 707;"W0X" ! Disable trigger delay.

4.2.23 X — Execute

Purpose To direct the Model 182 to execute device-dependent commands received since last X

Format <command>X

Parameters None

Description The execute command is implemented by sending an ASCII "X" over the bus. Its purpose is to direct the unit to execute other device-dependent commands such as R (range). Usually, the execute character is the last character in the command string (a number of commands may be grouped together into one string); however, there may be certain cases when it is desirable to send a command string at one time, and then send the execute character later on.

Programming Notes

1. Commands or command strings sent without the X character are not executed at that time, but they are stored in an internal command buffer for later execution. When the X character is finally transmitted, the stored commands are executed, assuming that all commands in the previous string were valid.
2. Commands are not necessarily executed in the order sent (see Table 4-2). To force a particular command sequence, include the X character after each command in the command string.
3. If an error is detected in the command string, no commands up to the "X" will be executed.

Programming Examples

10	OUTPUT 707;"R1X"	! Execute single command.
20	OUTPUT 707;"R0G1X"	! Execute multiple command string.
30	OUTPUT 707;"T0XW100X"	! Force command sequence.
40	OUTPUT 707;"A1B1"	! Send string without executing.
50	OUTPUT 707;"X"	! Execute previous command string.

4.2.24

Y — Terminator**Purpose**

To select the ASCII terminator sequence that marks the end of the reading and U command output strings

Format

Yn

Parameters

Y0	<CR LF>
Y1	<LF CR>
Y2	<CR>
Y3	<LF>
Y10	<CR LF>
Y13	<LF CR>

Default

Upon power-up, or after receiving a DCL, SDC, or L1X or L2X command, the instrument returns to the factory default, which is Y0 (<CR><LF>).

Description

By using the Y command, you can program the number and type of terminator characters the instrument sends at the end of its default output and alternate output strings. Available terminator characters are the commonly used CR (carriage return, ASCII 13) and LF (line feed, ASCII 10) characters. These terminators are recognized by most controllers.

Programming Notes

1. Selecting the wrong terminator for the controller could cause the bus to hang when attempting to read data from the instrument.
2. EOI will be asserted with the last terminator character if enabled with the K command (paragraph 4.2.10).

Programming Examples

10	OUTPUT 707;"Y1X"	! Terminate on <LF> <CR>.
20	OUTPUT 707;"Y0X"	! Restore default terminator.

4.2.25 Z — Reading Relative

Purpose To enable/disable reading relative, and to program the reading relative value

Format Zn or Zn,value

Parameters

Z0	Disable reading relative
Z1	Enable reading relative using next reading
Z2,value	Enable reading relative using value ($\pm 1E-9$ to ± 30.3)
Z3	Enable reading relative using present value

Default Upon power-up, or after receiving a DCL, SDC, or L2X command, the instrument returns to the programmed default value. Factory default is reading relative disabled (Z0).

Description The Z command enables or disables reading relative in the same way as the front panel REL READING key. In addition, a feature allows you to program the reading relative value directly.

With Z1, the instrument will store the first triggered conversion after the command is received as the relative value. With Z2,value, you can program the relative value directly in volts. Z3 enables relative using the previously-stored reading relative value whether that value was stored using Z1 or Z2.

Additional information on using reading relative is located in paragraph 3.8.

Programming Notes

1. On the one-shot trigger mode, the instrument must be triggered with the appropriate trigger stimulus before it will store the reading relative value.
2. Programming a relative value larger than the present range can handle will result in an overflow condition.

Programming Examples

10	OUTPUT 707;"Z1X"	! Enable reading relative.
20	OUTPUT 707;"Z2,25E-3X"	! Enable relative, value=25mV.
30	OUTPUT 707;"Z0X"	! Disable relative.
40	OUTPUT 707;"Z3X"	! Enable relative using previous value.

4.3 GENERAL BUS COMMANDS

General bus commands are those IEEE-488 commands such as DCL (Device Clear) that have the same general meaning regardless of the instrument. Commands supported by the Model 182 are listed in Table 4-3, which also lists HP BASIC 4.0 statements necessary to send each command. Note that commands requiring that a primary address be specified assume that the primary address is set to 7 (the default primary address of the Model 182).

4.3.1 REN (Remote Enable)

The remote enable command is sent to the Model 182 by the controller to set up the instrument for remote operation. Generally, the instrument should be placed in the remote mode before attempting to program it over the bus. Simply setting REN true does not actually place the instrument in the remote state. Instead the instrument must be addressed to listen after setting REN true before it actually goes into remote.

Note that the instrument need not be in remote to be a talker.

Programming Example — The remote enable sequence is automatically performed by the controller when the following is typed into the keyboard.

```
REMOTE 707
```

After the RETURN key is pressed, the instrument is in the remote state, as indicated by the REM light. If not, check

to see that the instrument is set to the proper primary address (7), and check to see that the bus connections are properly made.

Note that all front panel controls except for LOCAL (and, of course, POWER) are inoperative while the instrument is in remote. You can restore normal front panel operation by pressing the LOCAL key (except when Local Lockout is in effect, in which case LOCAL will also be locked out).

4.3.2 IFC (Interface Clear)

The IFC command is sent by the controller to place the Model 182 in the local, talker and listener idle states. To send the IFC command, the controller need only set the IFC line true for a minimum of 100µsec. Note that the status byte, SRQ line, and SRQ annunciator are not affected by IFC.

Programming Example — Before demonstrating the IFC command, turn on the TALK indicator with the following statement:

```
ENTER 707;A$
```

At this point, the TALK light should be on. The IFC command can be sent by entering the following statement into the computer:

```
ABORT 7
```

After the RETURN key is pressed, the TALK indicator turns off, indicating that the instrument has gone into the talker idle state.

Table 4-3. General Bus Commands and Associated BASIC Statements

Command	HP BASIC 4.0 Statement	Effect on Model 182
REN	REMOTE 7	Goes into effect when next addressed to listen.
IFC	ABORT 7	Goes into talker and listener idle states.
LLO	LOCAL LOCKOUT 7	LOCAL key locked out.
GTL	LOCAL 707	Cancels remote, restores front panel operation.
DCL	CLEAR 7	Returns to power-up default conditions.
SDC	CLEAR 707	Returns to power-up default conditions.
SPE,SPD	SPOLL(707)	Serial polls 182, returns status byte.

4.3.3 LLO (Local Lockout)

The LLO command is used to prevent local operation of the instrument. After the unit receives LLO, all its front panel controls except POWER are inoperative.

Programming Example — The LLO command is sent by entering the following statements:

```
REMOTE 707  
LOCAL LOCKOUT 7
```

After the second statement is executed, the instrument's front panel controls are locked out, including the LOCAL key.

To restore front panel operation after asserting LLO, send GTL, as discussed in the following paragraph.

4.3.4 GTL (Go To Local)

The GTL command is used to take the instrument out of the remote state and restore operation of the front panel keys. GTL will also cancel LLO if the instrument is currently in the local lockout state.

Programming Example — Place the instrument in the remote state with the following statement:

```
REMOTE 707
```

Now send GTL with the following statement:

```
LOCAL 707
```

Note that the instrument goes into the local state, and that operation of the front panel keys has now been restored.

4.3.5 DCL (Device Clear)

The DCL command may be used to clear the Model 182 and return it to its power-up default conditions (see Table 4-4). Note that the DCL command is not an addressed

command, so all instruments designed to implement DCL will do so simultaneously. When the Model 182 receives a DCL command, it returns to the power-up default conditions, except for the programmed primary address, which is not affected by DCL. Note that the serial poll status byte, SRQ line, and SRQ annunciator are cleared by DCL.

Programming Example — Place the unit in an operating mode that is not a power-up default condition. Now enter the following statement from the controller keyboard:

```
CLEAR 7
```

When the RETURN key is pressed, the instrument returns to the power-up default conditions.

4.3.6 SDC (Selective Device Clear)

The SDC command is an addressed command that performs exactly the same function as the DCL command. However, since each device must be individually addressed, the SDC command provides a method to clear only selected instruments instead of clearing all instruments simultaneously, as is the case with DCL. When the Model 182 receives the SDC command, it returns to the power-up default conditions (Table 4-4). Like DCL, SDC does not affect the programmed primary address. Note that the serial poll status byte, SRQ line, and SRQ annunciator are cleared by SDC.

Programming Example — Place the unit in an operating mode that is not a power-up default condition. Now enter the following statement from the controller keyboard:

```
CLEAR 707
```

This command sends the following IEEE-488 commands: UNT UNL LISTEN 22 SDC. When the statement is executed, the instrument executes its power-up sequence and returns to the power-up default configuration.

4.3.7 SPE, SPD (Serial Polling)

The serial polling sequence is used to obtain the Model 182 status byte. The status byte contains important information about internal functions, as described in paragraph 4.2.10. Generally, the serial polling sequence is

used by the controller to determine which of several instruments has requested service with the SRQ line. Also, the serial polling sequence may be performed at any time to obtain the status byte from the Model 182.

Programming Example — The SPOLL statement automatically performs the serial poll sequence. To demonstrate serial polling, enter in the following program lines into the computer:

```
10 S=SPOLL (707)
20 PRINT "STATUS BYTE=";S
30 END
```

RUN the program and note that the decimal value of the status byte is displayed on the controller CRT.

must receive a talk command before transmitting data. The Model 182 is shipped from the factory with a programmed primary address of 7.

The primary address may be set to any value between 0 and 30 as long as address conflicts with other instruments are avoided. Note that controllers also use a primary address, so do not use the same address as the controller. Most frequently, controller addresses are 0 or 21, but you should consult the controller's instruction manual for details. Whatever primary address you choose, you must make certain that it corresponds with the value specified as part of the controller's programming language.

To check the present primary address or to change to a new one, perform the following procedure:

1. Press the MENU button, then press  twice to scroll to the following message:

SET IEEE ADDRESS

2. Press ENTER to display the current address:

IEEE Address: 07

3. To retain the current address and return to normal display, press ESC twice to exit from the menu.
4. To change the primary address, key in the new value using the numeric entry keys in the range of 0 to 30.

NOTE

Each device on the bus must have a unique primary address. Failure to observe this precaution will result in improper bus operation.

5. Press ENTER to complete programming the new address (or press ESC to cancel your entry and leave the address unchanged).

NOTE

The primary address is automatically saved as power-on default when entered.

6. Press ESC to exit the menu and return to normal display.

Table 4-4. Factory Default Conditions

Command	Description
B1	6 1/2-digit display resolution
F0*	A/D converter reading source
G1*	Reading with prefix data format
I0*	Buffer disabled
J0	Analog output disabled
K0*	EOI and hold-off enabled
M0*	SRQ disabled
N1	Filters on
O0	Analog filter disabled
P2	Medium response digital filter
Q0	Default trigger interval (250msec)
R5	30V range
S0	Line cycle integration period
T6	Multiple on external trigger
V0,1	Analog output source= meter, gain =1
W0	Trigger delay disabled
Y0*	<CR LF> terminator
Z0	Reading relative disabled

NOTE: Factory default conditions can be restored with the LIX command. DCL or SDC do not affect the primary address.

*These command states are not stored by save setup and will return to factory defaults with SDC, DCL, L1, or L2.

4.4 PRIMARY ADDRESS PROGRAMMING

The Model 182 must receive a listen command before responding to addressed commands. Similarly, the unit

4.5 FRONT PANEL ASPECTS OF IEEE-488 OPERATION

The following paragraphs discuss aspects of the front panel that are part of IEEE-488 operation, including messages, status indicators, and the LOCAL key.

4.5.1 Front Panel Error Messages

The Model 182 has a number of front panel error messages that are associated exclusively with IEEE-488 operations. These messages, which are listed in Table 4-5, inform you of certain conditions that occur when programming the instrument.

The following paragraphs describe only those front panel messages associated exclusively with IEEE-488 programming. Note that the instrument may be programmed to generate an SRQ, and the U1 error word can be checked for specific error conditions if any of these errors occur. See paragraphs 4.2.12 and 4.2.20.

INVALID COMMAND Error

An INVALID COMMAND error occurs when the unit receives an invalid device-dependent command over the bus. For example, the command string E1X includes an invalid command because "E" is an invalid command letter. When an invalid command is received, the instrument briefly displays the INVALID COMMAND error message.

NOTE

When an INVALID COMMAND error is detected in a command string, all commands in the string, up to and including the next X, are ignored.

To correct error conditions, send only valid commands. Refer to paragraph 4.2 for device-dependent command programming details. Note that an INVALID COMMAND error is also flagged in bit 0 of the U1 error status word, as discussed in paragraph 4.2.20.

INVALID FORMAT Error

An INVALID FORMAT error indicates that a command with improper format has been received. When an INVALID FORMAT error occurs, the INVALID FORMAT message will appear on the top line, and the specific error message summarized in Table 4-6 will appear on the bottom line. An INVALID FORMAT error is also flagged in bit 1 of the U1 error word (paragraph 4.2.9).

INVALID OPTION Error

Sending the instrument a valid command with an invalid option results in the display of the INVALID OPTION error message on the top line, along with the pertinent message listed in Table 4-7 appearing on the bottom line.

For example, the command K4X has an invalid option (4) that is not part of the instrument's programming language. Thus, although the command K is valid, the option is not, and the INVALID OPTION error results.

NOTE

When an INVALID OPTION error is detected in a command string, all commands in the string, up to and including the next X, are ignored.

Table 4-5. IEEE-488 Front Panel Error Messages

Message	Description
INVALID COMMAND	Invalid Device-Dependent Command
INVALID OPTION	Invalid Device-Dependent Command Option
INVALID FORMAT	Invalid Device-Dependent Command Format
NOT IN REMOTE	Unit is not in remote
TRIGGER NOT READY	Unit received trigger, but still processing previous trigger

Table 4-6. INVALID FORMAT Error Messages

Error Message	Comments
Invalid character	Invalid non-white space character found in input string
Repeated sign in integer	Repeated sign character for integer part
Sign in fraction	Received sign character in fractional part
Repeated sign in exponent	Received repeated sign character in exponent
Repeated decimal point	Received repeated decimal point in mantissa
Decimal point in exponent	Received decimal point in exponent
Multiple E's in exponent	Received multiple exponent (E) characters
Too many digits in exponent	Exponent greater than two digits
Too many digits in integer	Too many significant digits in integer part of fractional number
Too many digits in fraction	Too many significant digits in fractional part of fractional number

Table 4-7. INVALID OPTION Error Conditions

Error Message	Comments
Parameter value out of range	Consult specific command description for valid parameter range

To correct this error condition, use only valid command options, as discussed in paragraph 4.2. Note that an INVALID OPTION error is also flagged in bit 2 of the U1 error word, as discussed in paragraph 4.2.20.

NOT IN REMOTE Error

A NOT IN REMOTE error occurs if the instrument receives an "X" while the bus REN line is false. The NOT IN REMOTE error message is displayed under these conditions. This error is caused by failing to set the REN line true before addressing the Model 182 to listen. The NOT IN REMOTE error is also flagged in bit 3 of the U1 error word (paragraph 4.2.20).

TRIGGER NOT READY Error

A TRIGGER NOT READY error occurs when the instrument receives a trigger while it is still processing previously-sent commands. The TRIGGER NOT READY error is flagged in bit 16 of the U1 error word (paragraph 4.2.20).

4.5.2 IEEE-488 Status Indicators

The REM (remote), TALK, LSTN (listen), and SRQ (service request) indicators show the present IEEE-488 status of the instrument. Each of these indicators is briefly described below.

REM — As the name implies, this indicator shows when the instrument is in the remote state. Note that REM does not necessarily indicate the state of the REN line, as the instrument must be addressed to listen with REN true before the REM indicator turns on. When the instrument is in remote, all front panel keys except for the LOCAL key are locked out (LOCAL will also be locked out if the LLO command was used). When REM is turned off (either by pressing LOCAL or sending GTL over the bus), the instrument is in the local state, and front panel operation is restored.

TALK — This indicator is on when the instrument is in the talker active state. The unit is placed in this state by addressing it to talk with the correct MTA (My Talk Address) command. TALK is off when the unit is in the

talker idle state. The instrument is placed in the talker idle state by sending it an UNT (Untalk) command, addressing it to listen, or with the IFC (Interface Clear) command.

LSTN — This indicator is on when the Model 182 is in the listener active state, which is activated by addressing the instrument to listen with the correct MLA (My Listen Address) command. LSTN is off when the unit is in the listener idle state. The unit can be placed in the listener idle state by sending UNL (Unlisten), addressing it to talk, or by sending IFC (Interface Clear) over the bus.

SRQ — This indicator shows that the Model 182 has generated a service request over the bus. Conditions that can generate a service request include: overload, ready for a command, and a number of error conditions such as INVALID COMMAND and INVALID OPTION. Refer to paragraph 4.2.12 for additional SRQ information.

4.5.3 LOCAL Key

The LOCAL key cancels the remote state and restores local operation of the instrument.

Since all front panel keys except LOCAL are locked out when the instrument is in remote, this key provides a convenient method of restoring front panel operation. Pressing LOCAL also turns off the REM indicator.

Note that the LOCAL key is also inoperative if the LLO (Local Lockout) command is in effect.

4.6 BUS CONNECTIONS

The following paragraphs discuss bus connections, recommended connecting cables, as well as contact designations.

4.6.1 Recommended Cables

In order to minimize the possibility of electrical interference, use only shielded IEEE-488 cables such as the Keithley Model 7007-1 or 7007-2.

4.6.2 Typical Connections

A typical connecting scheme for a multiple-instrument setup is shown in Figure 4-22. To make connections to the Model 182, simply line up the mating connector with the IEEE-488 connector on the rear panel, then seat the connector firmly. Tighten the screws securely, then make sure the other end of the cable is connected to the controller or other device as the case may be. Theoretically, a large number of connectors could be stacked on one instrument, but it is recommended that you stack no more than three connectors on any one instrument to avoid possible mechanical damage.

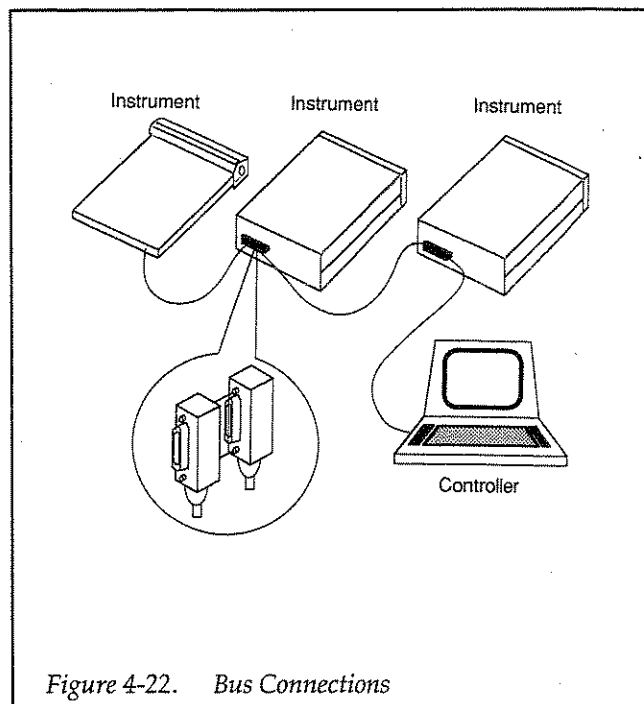

4.6.3 Bus Limitations

The IEEE-488 bus is limited to a maximum of 15 devices including the controller. The maximum cable length is 20 meters, or two meters times the number of devices connected, whichever is less. Failure to observe these limits may result in improper bus operation.

4.6.4 Contact Designations

Table 4-8 lists contact assignments for the IEEE-488 bus.

Table 4-8. IEEE-488 Contact Assignments

Contact Number	IEEE-488 Designation	Type
1	DIO1	Data
2	DIO2	Data
3	DIO3	Data
4	DIO4	Data
5	EOI (24)*	Management
6	DAV	Handshake
7	NRFD	Handshake
8	NDAC	Handshake
9	IFC	Management
10	SRQ	Management
11	ATN	Management
12	Shield	Ground
13	DIO5	Data
14	DIO6	Data
15	DIO7	Data
16	DIO8	Data
17	REN (24)*	Management
18	Gnd. (6)*	Ground
19	Gnd. (7)*	Ground
20	Gnd. (8)*	Ground
21	Gnd. (9)*	Ground
22	Gnd. (10)*	Ground
23	Gnd. (11)*	Ground
24	Logic Gnd.	Ground

*Numbers in parentheses refer to signal ground return of referenced contact number.

SECTION 5

Performance Verification

5.1 INTRODUCTION

This section contains information on verifying the measurement and analog output accuracy of the Model 182 Sensitive Digital Voltmeter.

WARNING

The information in this section is intended only for qualified personnel who are familiar with the procedures for using electronics test equipment. Do not attempt to perform these procedures unless you are qualified to do so.

NOTE

If the instrument is still under warranty, and its performance is not within specified limits, contact your Keithley representative or the factory to determine the correct course of action.

This section is arranged as follows:

5.2 Environmental Conditions: States the proper temperature and humidity limits for the tests.

5.3 Initial Conditions: Details the correct warm-up procedure for the tests.

5.4 Recommended Test Equipment: Summarizes the test equipment required to perform the verification procedures.

5.5 Verification Limits: Discusses the stated limits defined in this section.

5.6 Verification Procedures: Details the procedures for checking voltage measurement accuracy, as well as accuracy of the analog output.

5.2 ENVIRONMENTAL CONDITIONS

All measurements should be made at $23^{\circ}\pm 1^{\circ}\text{C}$ and at less than 70% relative humidity unless otherwise noted.

5.3 INITIAL CONDITIONS

The Model 182 should be turned on and allowed to warm up for at least one hour before beginning the verification procedures. In addition, the test equipment should be allowed to warm up for the period specified by the manufacturer. If any of the equipment has been subjected to temperature or humidity extremes, additional time should be allowed for temperatures to stabilize. Typically, it takes one additional hour to stabilize a unit that is 10°C (18°F) outside the specified temperature range.

5.4 RECOMMENDED TEST EQUIPMENT

Table 5-1 and Table 5-2 list test equipment recommended for performing the verification procedures.

Table 5-1. Recommended Test Equipment for Measurement Accuracy Verification

Manufacturer	Model	Description	Specifications*
Datron	4708	DC Calibrator (option 10)	100mV range: $\pm(7\text{ppm OUTPUT} + 0.4\mu\text{V})$ 1V range: $\pm(4\text{ppm OUTPUT} + 0.8\mu\text{V})$ 10V range: $\pm(2.5\text{ppm OUTPUT} + 3\mu\text{V})$
Keithley	262	Low Thermal Divider	100:1 division, $\pm 35\text{ppm}$ accuracy @ $23^\circ\text{C} \pm 1^\circ\text{C}$, $\pm 5\text{ppm}$ short-term accuracy @ $23^\circ\text{C} \pm 1^\circ\text{C}$ (see text)
Keithley	1507	Low Thermal Cable	

* DC calibrator specifications shown include 90-day $23^\circ\text{C} \pm 1^\circ\text{C}$ accuracy and calibration uncertainty specifications.
Model 262 error includes a short-term transfer error of $\pm 5\text{ppm}$ @ $23^\circ\text{C} \pm 1^\circ\text{C}$.

Table 5-2. Recommended Test Equipment for Analog Output Accuracy Verification

Manufacturer	Model	Description
Keithley	1507	Low-thermal cable
Keithley	7754-3	BNC to dual alligator clips cable

5.5 VERIFICATION LIMITS

5.5.1 Test Equipment Accuracy Specifications

The measurement verification limits give in this section include the accuracy specifications of the specific DC calibrator listed in Table 5-1. Note that the stated calibrator tolerances include both 90-day $23^\circ\text{C} \pm 1^\circ\text{C}$ accuracy and calibration uncertainty specifications.

5.5.2 Model 182 Accuracy Specifications

The stated limits for accuracy are based both on 90-day and one-year Model 182 specifications. Refer the Model 182 specifications located at the front of this manual for complete details on these specifications.

5.6 VERIFICATION PROCEDURES

5.6.1 Measurement Accuracy Verification

The following paragraphs give detailed procedures for verifying measurement accuracy. Measurement accuracy verification procedures for the 300mV-30V and 3mV and 30mV ranges are given separately because of the different equipment required.

300mV, 3V, and 30V Range Verification

NOTE

The following procedure must be performed at $23^\circ\text{C} \pm 1^\circ\text{C}$ because of DC calibrator accuracy specifications.

1. With the power off, connect the Model 182 to the DC calibrator as shown in Figure 5-1.

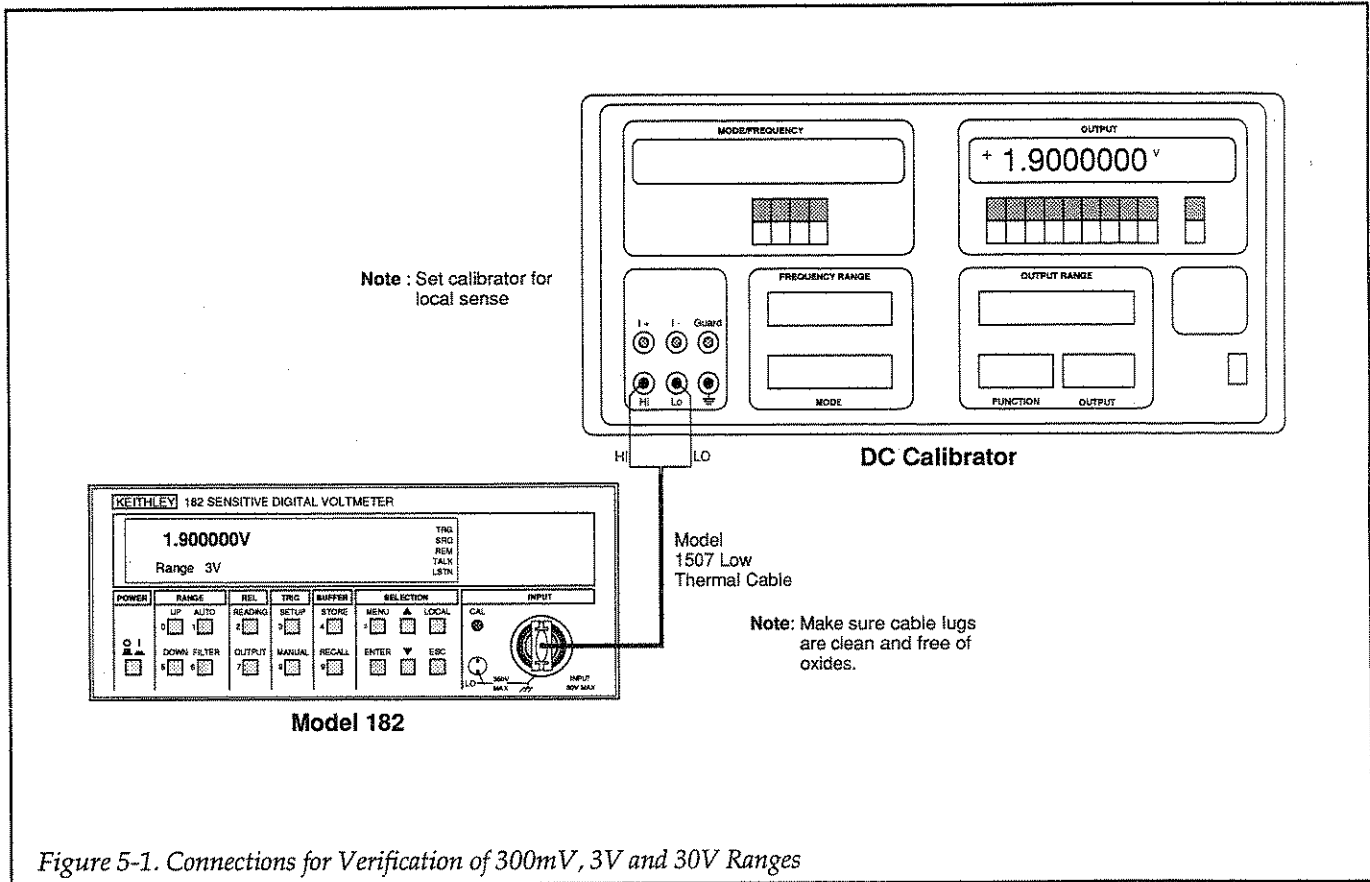

Figure 5-1. Connections for Verification of 300mV, 3V and 30V Ranges

CAUTION

Remove all shorting links from between calibrator terminals.

NOTE

Make sure that the cable connecting lugs are clean and free of oxides. Use Scotchbrite or other similar product to remove any oxidation that might be present.

2. Turn on the Model 182 and the DC calibrator and allow the units to warm up for at least one hour before beginning the verification procedure. Be sure the calibrator is set up for local sensing.
3. Return the Model 182 to factory default conditions as follows:
 - A. Press MENU.
 - B. Press ▲ three times to display the following message:

SETUP

- C. Press ENTER, then use ▲ or ▼ to display the following:

Recall Factory

- D. Press ENTER to recall the factory defaults.
- E. Press ESC to return to normal display after defaults have been recalled.
4. Set the DC calibrator to the 100mV range.
5. Turn on the DC calibrator output, and set the calibrator output to 0.00000mV.
6. Set the Model 182 to the 300mV range.
7. Allow the Model 182 reading to settle, then press REL READING to null any offsets. Leave REL READING enabled for the rest of the procedure.
8. Set the DC calibrator output to 190.000mV, and allow the reading to settle. Verify that the Model 182 is within the 90-day or one-year limits given for step 1 of Table 5-3.
9. Select the Model 182 3V range.
10. Select the 1V range on the calibrator, and set the calibrator output to 1.900000V.
11. Allow the reading to settle, then verify that the Model 182 reading is within the 90-day or one-year limits for step 2 of Table 5-3.

Table 5-3. Measurement Verification Summary (300mV, 3V, and 30V Ranges)

Step	182 Range	Calibrator Range	Calibrator Output	Allowed Reading Range (23°C ±1°C)*	
				90-Day Specifications	One-Year Specifications
1	300mV	100mV	190.000mV	189.9928mV to 190.0072mV	189.9890mV to 190.0110mV
2	3V	1V	1.90000V	1.899926V to 1.900074V	1.899888V to 1.900112V
3	30V	10V	19.0000V	18.99923V to 19.00077V	18.99885V to 19.00115V

* Reading limits include stated accuracy specifications of DC calibrator listed in Table 5-1 and appropriate Model 182 90-day or one-year specifications (including factory calibration uncertainty). Stated temperature tolerance is required due to DC calibrator tolerance which is specified at 23°C ±1°C.

12. Select the Model 182 30V range.
 13. Select the 10V range on the calibrator, and set the calibrator output to 19.00000V.
 14. Allow the reading to settle, then verify that the Model 182 reading is within the 90-day or one-year limits for step 3 of Table 5-3.
 15. Repeat steps 4 through 13 for negative voltages of the same magnitude. Readings should be within the limits stated in Table 5-3, except, of course, for the fact the readings will be negative.
3. Set the DC calibrator to the 100mV range, and set the calibrator output to 00.0000mV. Make sure the calibrator output is turned on.
 4. Select the 300mV range on the Model 182.
 5. Allow the reading to settle completely, the press REL READING on the Model 182.
 6. Set the DC calibrator output to 190.0000mV.
 7. Allow the Model 182 reading to settle completely, then note the displayed Model 182 reading. Record this reading here: _____ mV.
 8. Turn off the calibrator output, then disconnect the DC calibrator from the Model 182. Connect the DC calibrator, Model 262 Low Thermal Divider, and the Model 182 together as shown in Figure 5-2.

NOTE

Leave the DC calibrator connected to the Model 182 INPUT for the time being because the calibrator will be used to establish a reference for low thermal divider characterization.

CAUTION

Make certain all shorting links have been removed from the DC calibrator terminals.

3mV and 30mV Range Verification

NOTE

The following procedure must be performed at 23°C ±1°C because of DC calibrator accuracy specifications. Also make sure the instrument passes the 300mV verification procedure outlined above before performing this procedure.

1. Make sure the DC calibrator is still connected to the Model 182 INPUT jack (Figure 5-1), and that the calibrator is still set up for local sensing.
2. Make sure the Model 182 is still set up for factory defaults.

Steps 3 through 7 below establish a reference reading for divider characterization.

NOTE

Make sure all connecting wires and lugs are clean and free of oxides.

9. Place the DC calibrator in the remote sensing mode (the calibrator output must be turned OFF to change sense modes).

Steps 10 through 15 below characterize the Model 262 Low Thermal Divider to cancel out any gain error that might be present.

10. Set the DC calibrator to the 10V range with 0.0000V output. Turn on the DC calibrator output.
11. Set the Model 262 divider to POS+ output, and select a 100:1 (10²:1) divider ratio.
12. Select the 300mV range on the Model 182, and disable REL READING.
13. Allow the reading to settle completely, then enable REL READING.

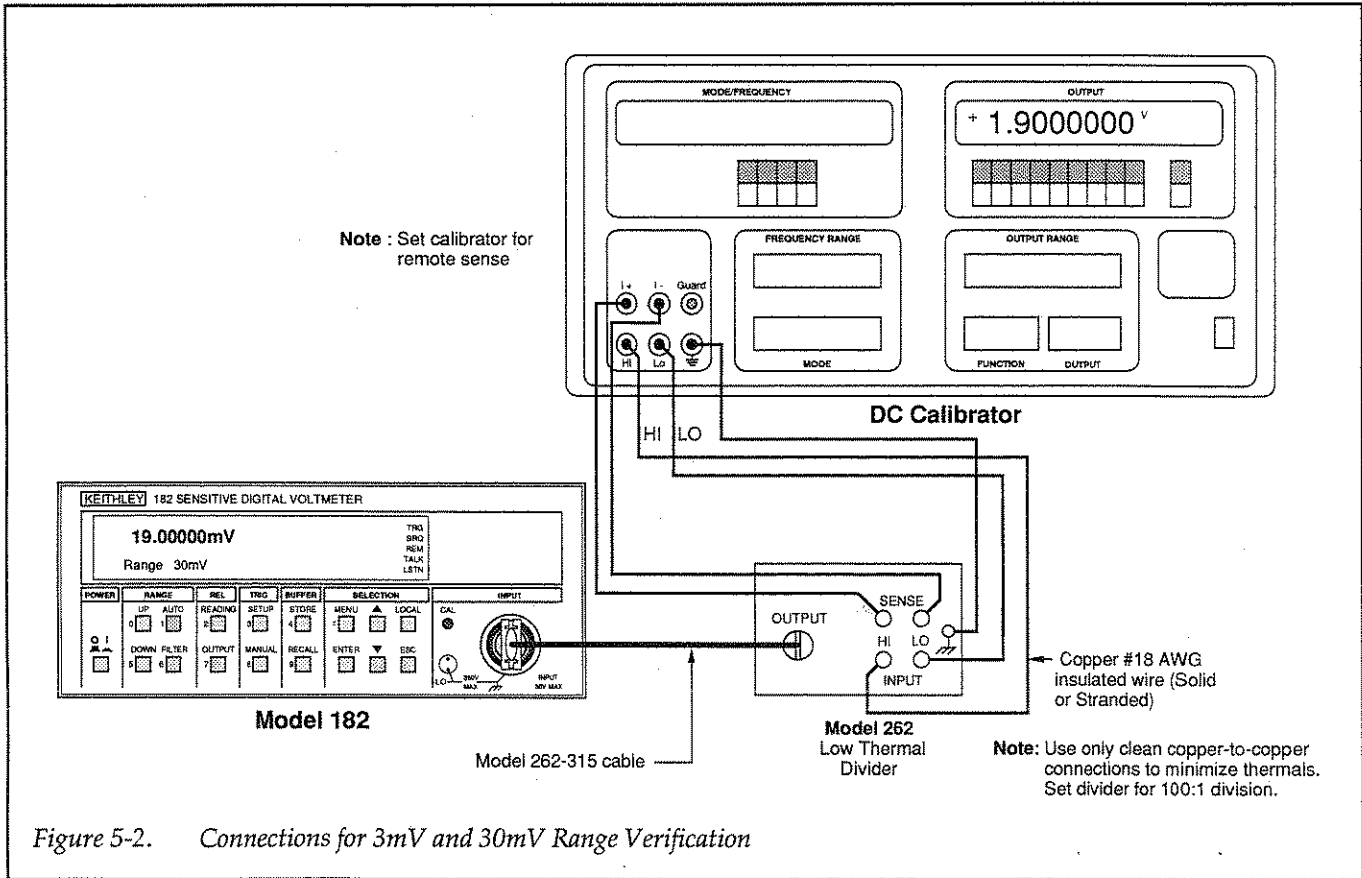

Figure 5-2. Connections for 3mV and 30mV Range Verification

14. Set the DC calibrator output to approximately 19V, then adjust the DC calibrator output voltage so that the Model 182 reading is exactly the same as the reading you obtained in step 7 above. (This step corrects for gain error in the Model 262 Low Thermal Divider, thus nulling out divider error terms in the overall verification procedure.)
15. For reference purposes, record the exact DC calibrator voltage setting you obtained by performing the output voltage adjustment procedure in step 14 above. Calibrator voltage setting: _____ V.
17. Select the 30mV range on the Model 182, and disable REL READING.
18. Allow the reading to settle completely, then enable REL READING.
19. Divide the calibrator voltage value you obtained in step 15 above by a factor of 10, then set the DC calibrator output to that calculated voltage value. For example, if you obtained a calibrator voltage of 19.002V in step 15, you would set the DC calibrator output to 1.9002V.

Steps 16 through 25 below verify that Model 182 3mV and 30mV range measurements are within required limits.

NOTE

The steps below should be performed within 20 minutes of low thermal divider characterization to minimize short-term drift errors.

16. Set the DC calibrator to the 1V range, and set the calibrator output to 0.00000V. Make sure the calibrator output is turned on.
20. Allow the reading to settle, then verify that the reading is within the 90-day or one-year limits for step 1 (30mV range) of Table 5-4.
21. Leave the DC calibrator on the 1V range, and set the calibrator output to 0.00000V.
22. Select the 3mV range on the Model 182, and disable REL READING.
23. Allow the reading to settle, then enable REL READING on the Model 182.
24. Divide the calibrator voltage setting you obtained in step 15 by a factor of 100, then set the DC calibrator output to that calculated value. For example, if you obtained a voltage of 19.002V in step 15, you would now set the DC calibrator output to 0.19002V.

Table 5-4. Measurement Verification Summary (3mV and 30mV Ranges)

Step	182 Range	Allowed Reading Range (23°C ±1°C)*	
		90-Day Specifications	One-Year Specifications
1	30mV	18.99922mV to 19.00078mV	18.99884mV to 19.00116mV
2	3mV	1.899897mV to 1.900103mV	1.899859 to 1.900141mV

* Reading limits include stated accuracy specifications of DC calibrator listed in Table 5-1, 5ppm short-term low thermal divider accuracy, and appropriate Model 182 90-day or one-year specifications (including factory calibration uncertainty). Stated temperature tolerance is required due to DC calibrator tolerance which is specified at 23°C ±1°C.

NOTE

Keep the DC calibrator on the 1V range. Do not set the DC calibrator to the 100mV range because of resulting excessive errors (the output impedance increases to 100Ω, and remote sensing turns off on the 100mV range).

25. Verify that the Model 182 reading is within the 90-day or one-year limits for step 2 (3mV range) of Table 5-4.
26. Repeat steps 4 through 25 for negative voltages of the same magnitude. Model 182 readings should be within the limits stated in Table 5-4 except, of course, for the fact the readings will be negative.

NOTE

For maximum verification accuracy, the entire procedure (including divider characterization) should be repeated for negative voltages.

5.6.2 Analog Output Accuracy Verification

Use the following procedure to verify the accuracy of the analog output.

NOTE

This procedure uses the Model 182 to measure its own output. Be sure that measurement accuracy is within specified limits before attempting this procedure. This procedure can be performed at 18°C–28°C ambient temperature.

1. Turn on the Model 182, and allow it to warm up for at least one hour before performing the verification procedure.
2. Initially, set up the Model 182 as follows:
 RANGE: 3V
 FILTER: On
 Filter Response: Fast (use MENU FILTER selection to set)
 Display Resolution: 5 1/2-digits (use MENU DISPLAY RESOLUTION)
 REL READING: Off
 TRIG: Multiple on Manual (press MANUAL if necessary to take readings)
3. Program the analog output source as follows:
 A. Press MENU.
 B. Use ▲ to scroll to the following message:

CALIBRATE

- C. Press ENTER.
- D. Use ▲ or ▼ to scroll to the following message:

Configure Output

- E. Press ENTER.
- F. Use ▲ or ▼ to scroll to the following message:

Output:Source

- G. Press ENTER
- H. Key in a source value of 0.000, then press ENTER.
- I. Press ESC three times to return to normal reading display.

4. Connect the Model 182 ANALOG OUTPUT jack to the INPUT jack, as shown in Figure 5-3. The alligator clips and lugs from the two connecting cables can be simply clipped together. Be sure to connect INPUT LO to the outer shell of the ANALOG OUTPUT jack.

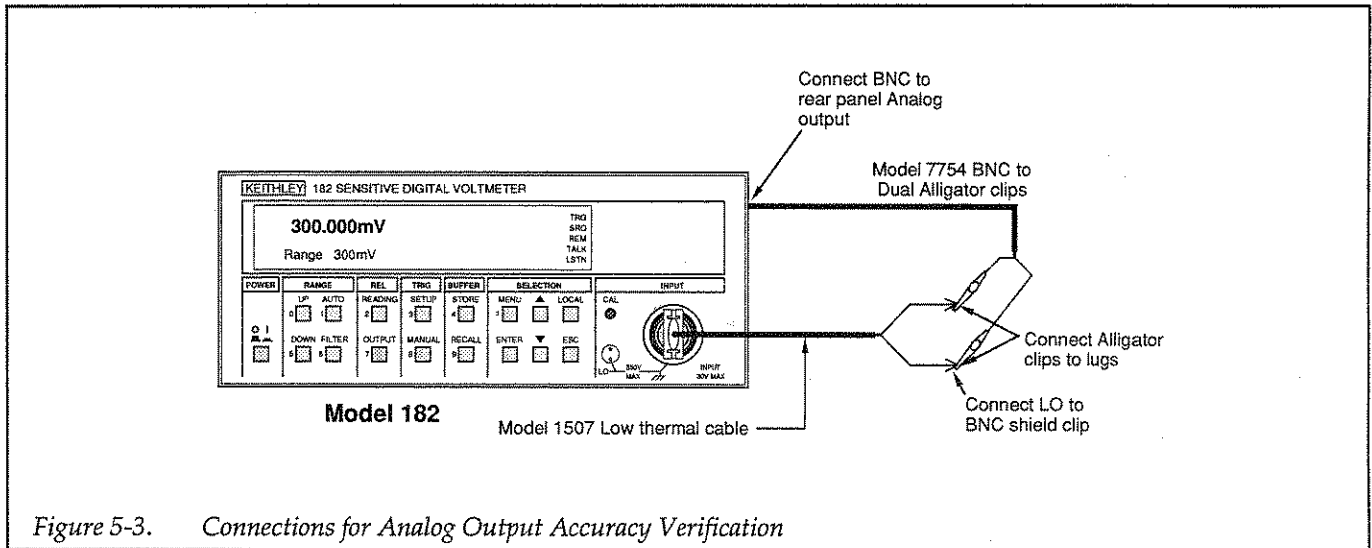

Figure 5-3. Connections for Analog Output Accuracy Verification

Table 5-5. Analog Output Verification Summary

Step	182 Range	Analog Output Source Value	Allowed 182 Reading Range* (18°C to 28°C)
1	3V	+3.000V	2.99464 to 3.00536V
2	3V	-3.000V	-2.99464 to -3.00536V
3	300mV	+0.300V	298.54 to 301.46mV
4	300mV	-0.300V	-298.54 to -301.46mV

* Limits include Model 182 measurement accuracy based on one-year specifications.

5. Allow the reading to settle, then press REL READING to null any offsets.
6. Program the analog output source for a value of +3.000V (see step 3 for procedure).
7. After settling, verify that the voltage reading on the display is within the limits shown for step 1 in Table 5-5.
8. Repeat steps 6 and 7 for the remaining output values listed in Table 5-5. Be sure to select the 300mV measurement range where appropriate.

SECTION 6

Theory of Operation

6.1 INTRODUCTION

Section 6 contains detailed electronics operating theory for the various circuits within the Model 182, and it contains the following information:

6.2 Block Diagram: Gives an overview of instrument circuits in block diagram form.

6.3 Analog Circuits: Covers in detail the various analog circuits.

6.4 Digital Circuits: Describes the digital circuits, including the main microprocessor and the IEEE-488 interface.

6.5 Display/Keyboard: Discusses the front panel vacuum fluorescent display and keyboard matrix.

6.6 Power Supplies: Covers the power supplies that supply both the analog and digital circuits within the instrument.

6.2 BLOCK DIAGRAM

Figure 6-1 shows the overall block diagram of the instrument. The purpose of each major block is described below.

Digital Board: contains the main processor that supervises operation of the instrument with the aid of the A/D and front panel microcontrollers. The digital board also includes the IEEE-488 interface, analog output D/A converter, as well as its own +5V regulator. The +60V and 5VAC filament supplies for the VFD (vacuum fluorescent display) are also located on the digital board.

Analog Board: includes signal conditioning circuits, A/D converter, A/D microcontroller, and power supplies for most of the circuits in the instrument.

Display Board: includes the front panel microcontroller, the vacuum fluorescent display module, and keyboard circuits.

6.3 ANALOG CIRCUITS

The following paragraphs discuss the various analog circuits. Analog circuits are detailed on drawing number 182-106, located at the end of Section 8.

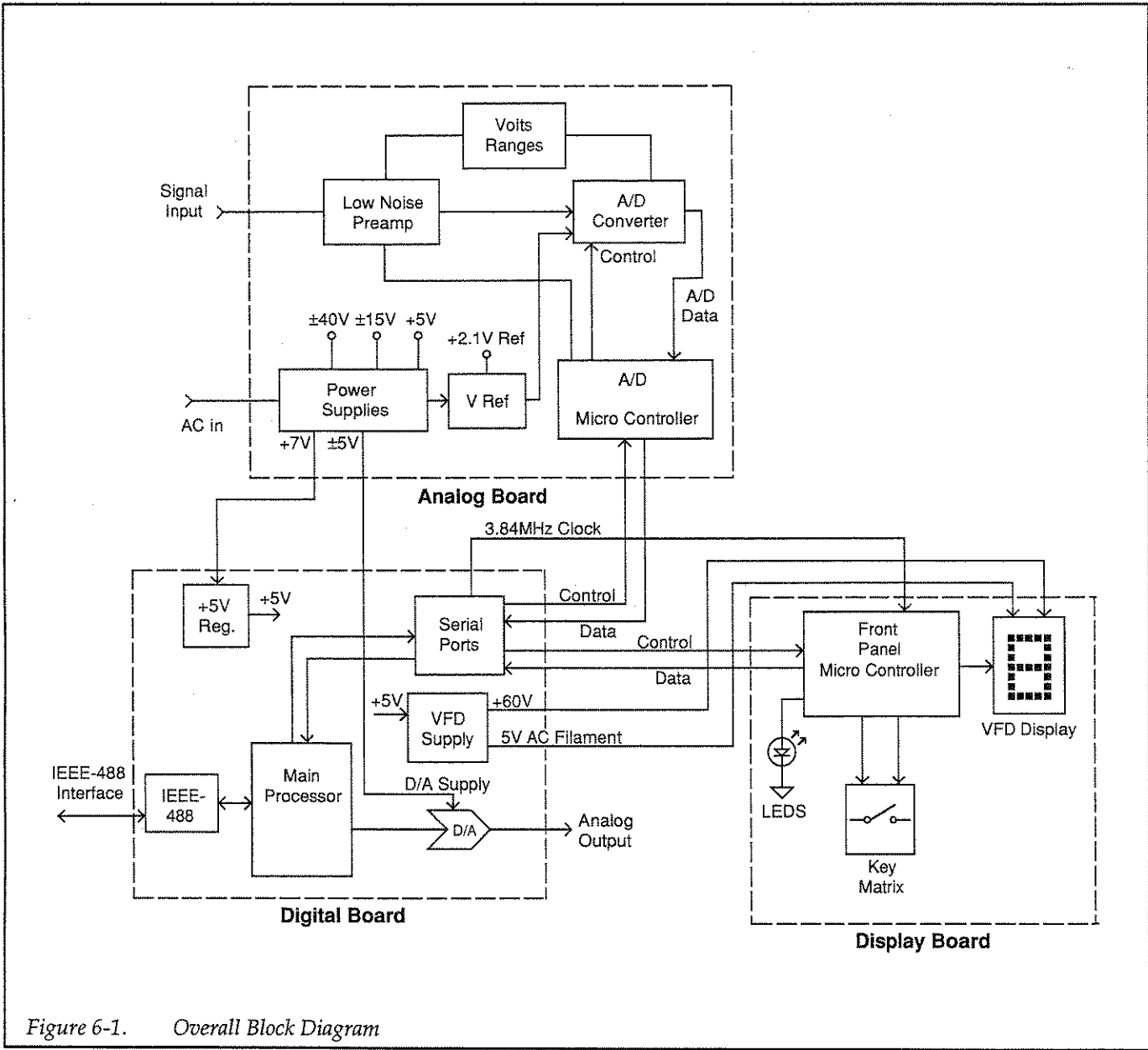

Figure 6-1. Overall Block Diagram

6.3.1 Simplified Analog Schematic

Figure 6-2 shows a simplified schematic diagram of the analog circuits, while Figure 6-3 shows a simplified signal flow diagram. The analog circuits can be grouped into five major sections: the nanovolt preamplifier, the 30V buffer, the A/D converter and its microcontroller, the input protection circuits, and the calibration circuits. Each of these major sections is covered in detail in the following paragraphs

6.3.2 Nanovolt Preamplifier

The nanovolt preamplifier amplifies low-level input voltages and boosts their amplitudes up to a level suitable for the A/D converter to process. Specially-designed circuits make sure that unwanted noise, thermal EMFs, and offsets are kept to a minimum.

The nanovolt preamplifier can be broken down into three sections: the low thermal input circuit, the preamplifier itself, and the NMRR filter section.

Low-thermal Input Circuit

The low-thermal input circuit is specially designed to minimize thermal offset generation that would otherwise degrade low-level measurement accuracy. The major components of the low-thermal input circuit include the input connector (J1009) and input cable, the low-thermal connections (cold weld) on all cables to the PC board, and the lugs which connect the input cable to the PC board. Additional components include the protection resistor, R133, and the input multiplexer FETs, Q108 and Q111.

The low-thermal input circuit can be serviced by cleaning the lugs and copper pads, as discussed in paragraph 7.6 in Section 7.

Preamplifier

The main components of the preamplifier include the amplifier and its bootstrap, the mux pumpout compensation circuit, and the drift correction circuit.

The amplifier consist of two low-noise FETs (Q107 and Q112) in differential configuration, followed by a high-

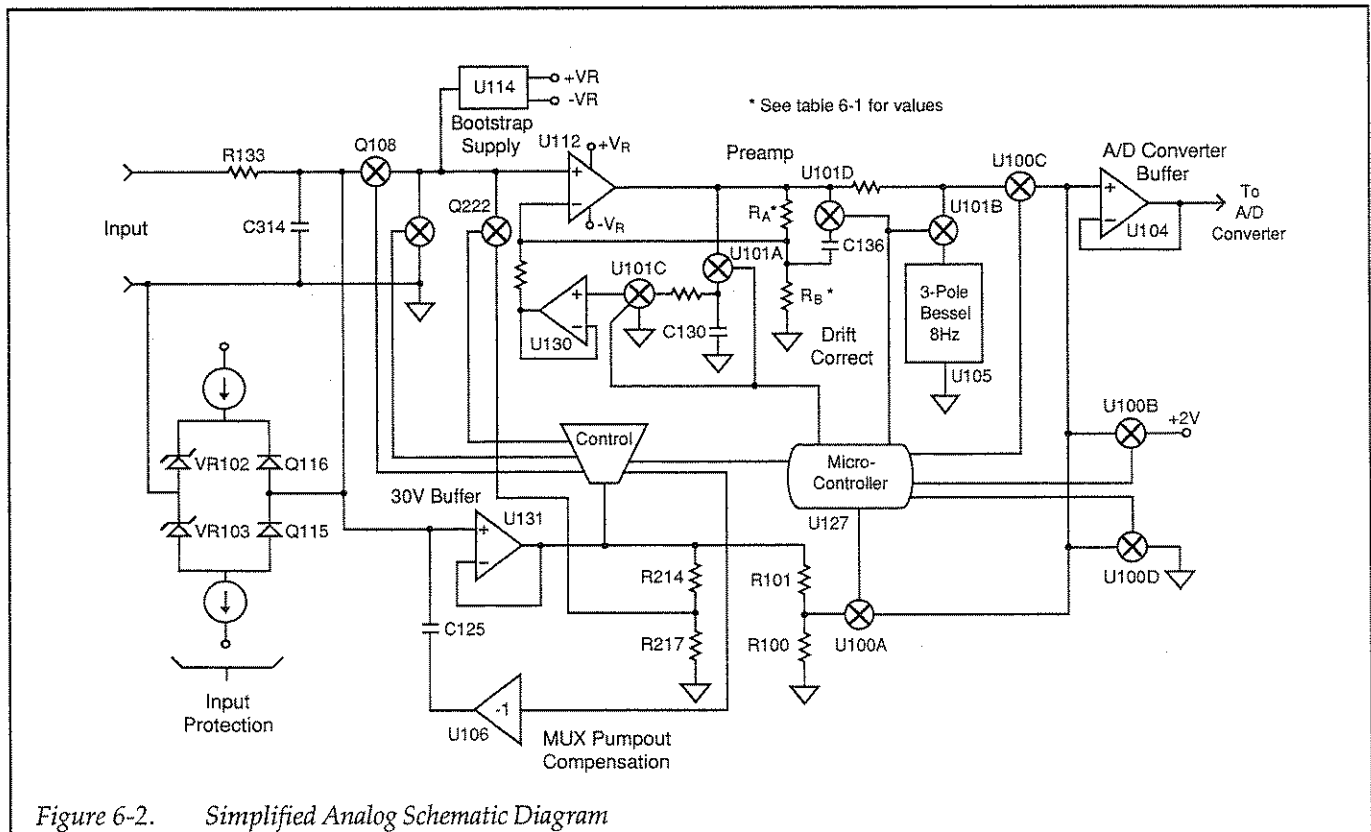
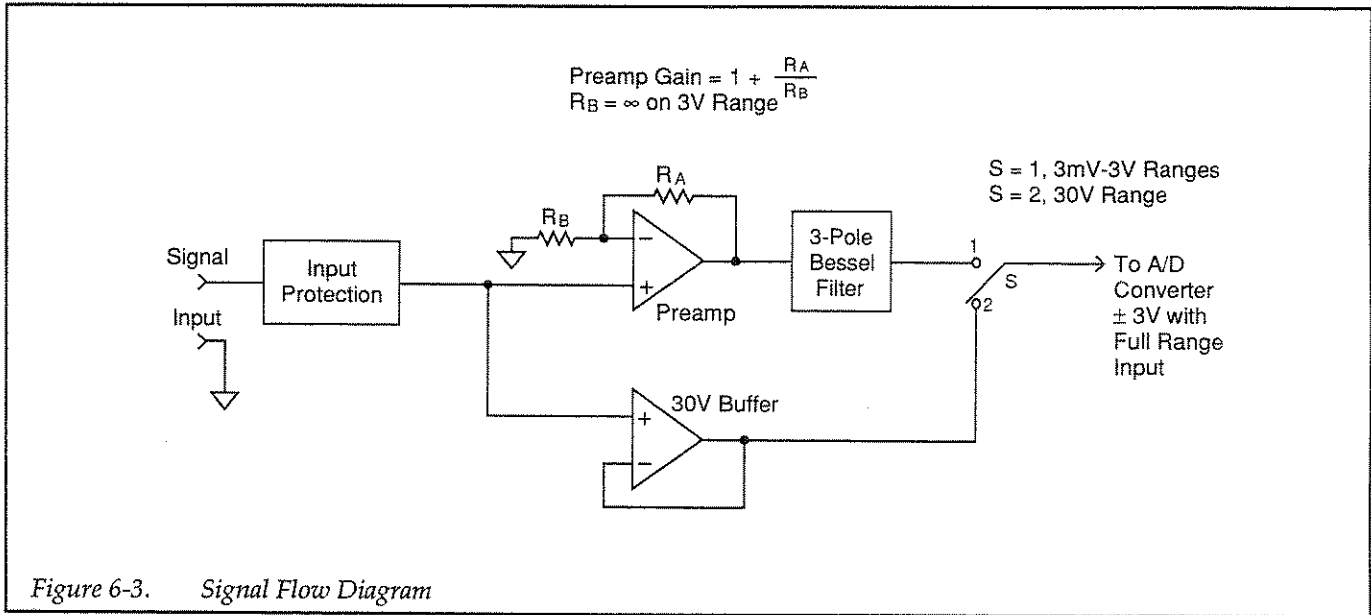

Figure 6-2. Simplified Analog Schematic Diagram



gain operational amplifier, U112. The differential amplifier is powered from a low-noise bootstrap supply, U114. The bootstrap supply keeps the +VR and -VR supply values at a constant potential relative to the input signal.

Negative feedback, which sets the overall gain of the amplifier, is achieved through low-noise, low temperature coefficient resistors. The correct resistor(s) are switched into the feedback circuit depending on the required gain, as summarized in Table 6-1.

Table 6-1. Preamp Gain Resistors

Range	Preamp Gain	Feedback Resistor(s)			
		R _A		R _B	
		Value	Desig.	Value	Desig.
3V	X1	5.62kΩ	R121	—	None
300mV	X10	18kΩ	R156	2kΩ	R203
30mV	X100	9.9kΩ	R195	100Ω	R202
3mV	X1000	100kΩ	R145	100Ω	R146

Preamplifier offset is measured on the 3mV and 30mV ranges using the drift correction circuit (C130, U101A, and U101C) during the reference or reference zero integration phases of the measurement cycle. The offset is then fed back to the main amplifier by U130 during the

signal and signal zero phases of the measurement cycle. This circuit ensures that the preamplifier operates within the required range. The mux pump out compensation circuit, U106, compensates for the charge delivered to input high from Q108 switching. The compensation charge is coupled through C125.

Analog Filter

The preamplifier (analog) filter is included to improve NMRR on all ranges except the 30V range. The first stage of the filter, made up of C136 and R146, reduces the gain of the main amplifier by -20dB/decade at 16Hz. The second stage, which consists of U105 and U101B, provides a three-pole Bessel function response at 8Hz. The total rejection of the filter including both stages is 35dB at 60Hz.

6.3.3 Input Protection

The input circuits are protected from transients of over voltage by the protection circuit made up of VR102, VR103, Q115, and Q116. This circuit clamps INPUT HI to 33V with respect to INPUT LO.

6.3.4 Auto-calibration

Calibration of the 3mV and 30mV ranges is not performed directly because of the difficulty of obtaining an accurate, stable calibration source at the required low voltage levels. Calibration of these two ranges is achieved with the aid of an internal low-noise resistive

divider which is used to divide a relatively high calibration voltage down to the levels required for 3mV and 30mV range.

Figure 6-4 shows a simplified diagram of the auto-calibration circuit, which is used for 3mV and 30mV range calibration. The calibration signal is applied through the INPUT jack to the 30V buffer. The calibration signal is then divided by 100 by the low-noise, low-thermal resistive divide, R214 and R217. The divided signal is applied to the preamp input through mux FET Q130 where it is amplified and routed to the A/D converter for processing.

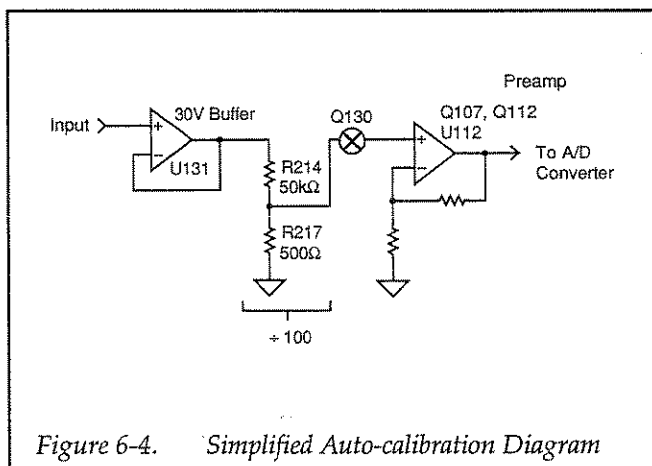

Figure 6-4. Simplified Auto-calibration Diagram

6.3.5 30V Buffer

The 30V buffer, U131, provides a high-impedance path around the preamplifier. The 30V buffer is used primarily to buffer the 30V range, but it also aids in determining and correcting for preamp overflow conditions. In addition, U131 provides a buffer for the low-thermal auto-calibration divider, and it also supplies a negative potential with respect to input high to disable the preamplifier input when the instrument is on the 30V range.

6.3.6 A/D Converter

A/D Microcontroller

The operation of both the A/D converter and the input preamplifier is controlled by the 68HC11 microcontroller, U127. Control data is optically coupled from the main processor through U144 to the microcontroller, which takes the control information, synchronizes the A/D converter and controls other functions such as pre-

amplifier gain, drift correction, and the analog filter. In a similar manner, reading data is sent back from the A/D microcontroller and optically coupled through U144. This optical coupling scheme is used to ensure electrical isolation between the digital circuits and sensitive analog circuits, thereby minimizing noise.

U127 is equipped with on-board RAM, but the device requires external ROM to store working code (U125). The same 7.68MHz clock that synchronizes the A/D converter is used for U127.

A/D Converter Operation

The Model 182 uses a constant-frequency, variable pulse width analog-to-digital converter. A simplified diagram of this converter is shown in Figure 6-5.

The charge balance phase begins when the measurement phase enable/disable line is set high. This occurs at the end of a software-generated delay period that allows the signal to settle after the appropriate multiplexer FET is turned on. Once the input is enabled, the signal from the buffer amplifier is added to the level shift current applied through R125 and R123. In this manner, the 3.03V bipolar signal from the buffer amplifier is converted to a unipolar signal that can be integrated.

The integrator is made up of U119 and C135. When the input to the integrator is applied, the integrator output ramps up until its voltage is slightly higher than the voltage applied to the inverting input of the duty cycle comparator, U122A. The charge balance current, whose duty cycle is proportional to the input, is fed back to the integrator input through R117 and Q101. Since the charge balance current is much larger than the sum of the input and level shift currents, the integrator output now ramps in the negative direction until the \bar{Q} output of U111 goes low. The microcontroller, U127, then counts the total number of pulses that occur during the charge balance phase.

At the end of the charge balance phase, the output of the integrator is resting at some positive voltage. Since the integrator output is connected to the non-inverting input of the final-slope comparator, U122B, the final-slope comparator output remains high until the integrator output ramps in the negative direction. During final-slope, Q101 is turned off, and the feedback is fed through U108 back to the integrator input. The final-slope comparator output is then gated with the 3.84Mhz clock and counted.

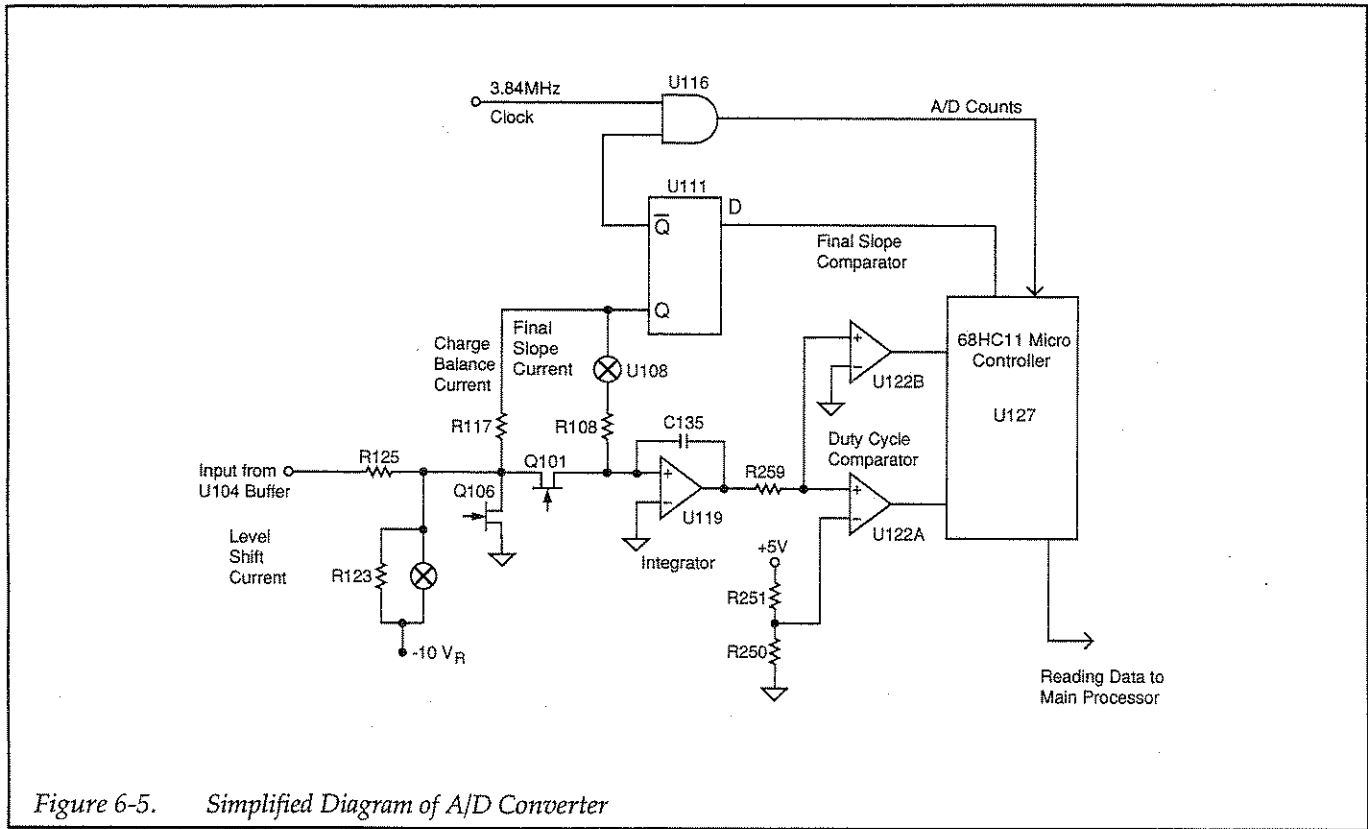

Figure 6-5. Simplified Diagram of A/D Converter

Once the comparator output goes low, the microcontroller, U127 stops counting, and the reading is computed.

Once computed, readings are serial transmitted to the main processor for further processing and display or transmission over the IEEE-488 bus.

6.4 DIGITAL CIRCUITS

The following paragraphs discuss the main digital circuits, which are located on drawing number 182-146, located at the end of Section 8.

6.4.1 Digital Block Diagram

Figure 6-6 shows a block diagram of the main digital circuits. Key sections include the main microprocessor, memory circuits, interrupt priority control, the serial ports, analog output, IEEE-488 interface, and miscellaneous I/O circuits.

6.4.2 Main Microprocessor

U509 is a 68HC000 microprocessor, which supervises all operating aspects of the instrument. This device is a 32/16-bit processor with a 16-bit external data bus and 32-bit internal processing capabilities. The 68HC000 has eight 32-bit data registers and eight 32-bit address registers.

The 10MHz SYSCLK clock signal is provided by Y500 and U510, which also provides the SYSCLK/4 and SYSCLK/2 clocks for other circuits.

6.4.3 Memory Circuits

U504 and U505 are 27C512 ROMs, which contain instruction coding for the main microprocessor. Working storage for the MPU is provided by U508 and U513, which are 43256 RAM ICs. Non-volatile storage for calibration constants and setup information is provided by U522, a 2K X 8 serial EEPROM.

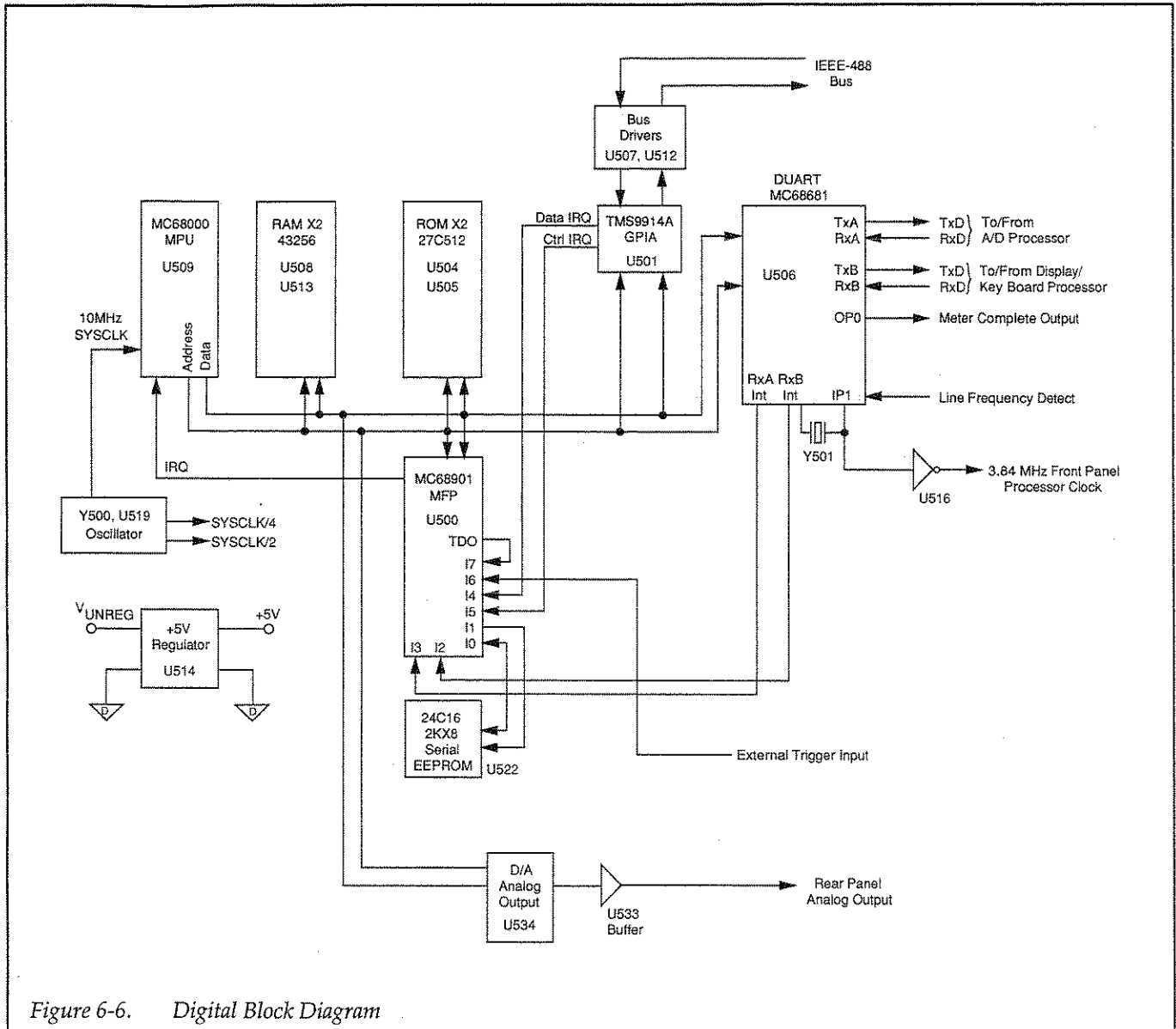

Figure 6-6. Digital Block Diagram

Address decoding is performed by U524. Figure 6-7 shows the memory map for the Model 182.

6.4.4 Interrupt Priority Control

Interrupt priority control for the MPU is provided by U500, a 68HC901 MFP (mult-function peripheral). Interrupts are prioritized with I7 having the highest priority and I0 having the lowest priority. The I7-I0 lines are used for the following functions:

- I7: 1msec system tick interrupt
- I6: external trigger input interrupt
- I5: IEEE-488 control interrupt
- I4: IEEE-488 data interrupt
- I3: A/D microcontroller interrupt
- I2: front panel microcontroller interrupt
- I1: serial EEPROM control
- I0: serial EEPROM data read/write

6.4.5 Serial I/O Ports

Dual serial I/O ports for communications to the front panel and A/D microcontrollers are provided by U506, a 68681 DUART (dual asynchronous receiver-transmitter). The TxA (transmit A) and RxA (receive A) lines provide serial communications to the A/D microcontroller for control and data information, while the TxB and RxB

lines communicate serial display and keyboard data to/from the front panel display/keyboard microcontroller.

U506 also controls the METER COMPLETE OUTPUT signal via its OP0 line, and it provides line frequency detection through the IP1 line. U506 also generates the 3.84MHz clock for the front panel microcontroller with the aid of Y501 and U516.

6.4.6 IEEE-488 Interface

The IEEE-488 interface is made up of three ICs. U501 is a 9914A GPIA (general purpose interface adapter) that performs many bus control and data I/O functions such as handshaking automatically, minimizing MPU overhead. Bus drive capabilities are provided by U507 and U512. U507 supports management and handshake lines, and U512 drives the data lines.

6.4.7 Analog Output

Digital information for the analog output is converted to an analog voltage by U534, a 14-bit D/A converter. The analog signal is buffered by U533 and fed to the rear panel ANALOG OUTPUT jack. Maximum nominal output voltage is $\pm 3.3V$, and maximum current is 5mA.

6.5 DISPLAY/KEYBOARD

The display/keyboard circuits are covered in the following paragraphs. A schematic diagram for the display board is located on drawing number 182-116, located at the end of Section 8.

6.5.1 Display Board Block Diagram

Figure 6-8 shows the overall block diagram of the display board. Major components include the display microcontroller, dot and digit drivers, the VFD, key matrix, and the LED drive circuits.

6.5.2 Display Microcontroller

U404 is the display microcontroller that controls the VFD and LEDs and interprets key data. The microcontroller has four peripheral I/O ports that are used for the various control and read functions.

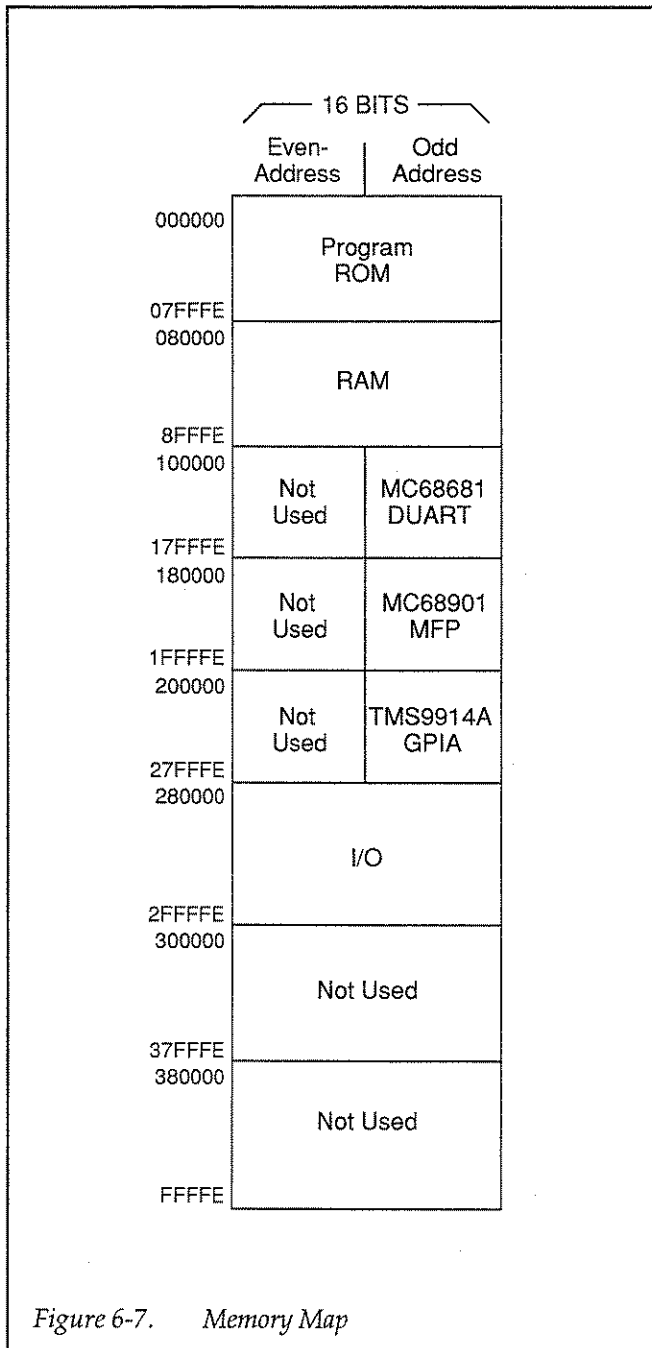

Figure 6-7. Memory Map

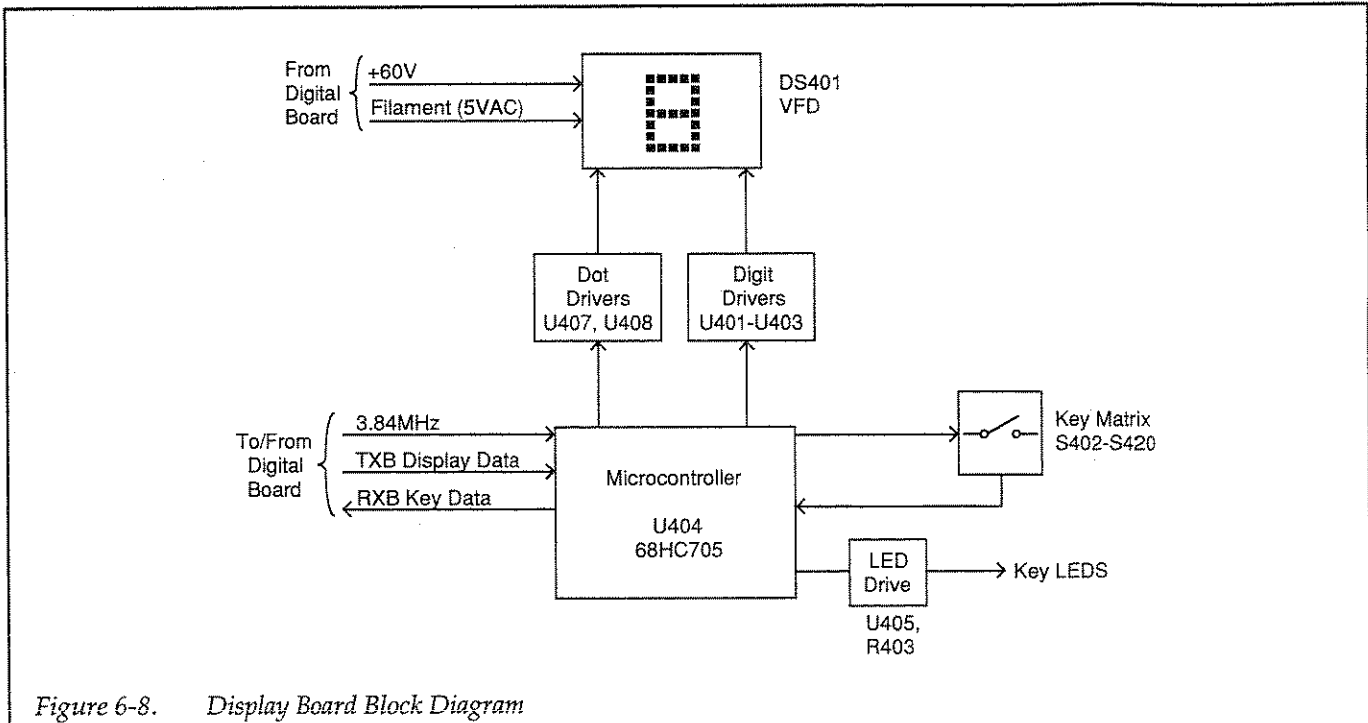

Figure 6-8. Display Board Block Diagram

Display data is serially transmitted to the microcontroller from the digital board via the TxB line to the microcontroller PD0 terminal. In a similar manner, key data is serially sent back to the digital board through the RxB line via PD1. Transmission parameters are as follows:

- Baud rate: 120kB
- Parity: none
- Data bits: 8
- Start bits: 1
- Stop bits: 1

Note that the 3.84MHz display microcontroller clock is generated on the main digital board.

6.5.3 Vacuum Fluorescent Display

DS401 is the VFD (vacuum fluorescent display) module, which can display up to 49 characters. Each character is organized as a 5X7 matrix of dots or pixels and includes a long under bar segment to act as a cursor.

The display uses a common multiplexing scheme with each character refreshed in sequence. U401-U403 are the digit drivers, while U407 and U408 are the dot drivers.

Note that dot driver and digit driver data is serially transmitted from the microcontroller PD3 line using the PD4 line as a clock signal.

The VFD requires both +60VDC and 5VAC for the filaments. These VFD voltages are supplied by U535, which is located on the digital board.

6.5.4 Key Matrix

The front panel keys (S402-S420) are organized into a row-column matrix to minimize the number of microcontroller peripheral lines required to read the keyboard. A key is read by strobing the columns and reading all rows for each strobed column. Key down data is interpreted by the display microcontroller and sent back to the main microprocessor using proprietary encoding schemes.

6.5.5 LED Drive Circuits

Many front panel keys such as FILTER and STORE use an integral LED to indicate when that particular function is active. U405 provides drive capabilities for the microcontroller LED on signals, while the resistive elements of R403 limit LED drive current to the required values. Since the LED cathodes are connected to digital com-

mon, an LED is turned on by setting the appropriate control line high.

6.6 POWER SUPPLIES

The various power supplies are discussed below. Most of the power supply circuits are located on the analog board, drawing number 182-106. The digital board regulator and VFD supply are located on the digital board, drawing number 182-146.

6.6.1 Power Supply Block Diagram

Figure 6-9 shows an overall block diagram of the power supply circuits. Key areas include the AC line input, two power transformers, analog supplies, reference supply, and the separate digital regulator and VFD supplies located on the digital board.

6.6.2 AC Line Input

AC power is applied to J1, which is located on the rear panel, through the line fuse F1001, to the line voltage selection switch, S1001. S1001 is used to select between 115V (nominal) and 230V operation.

After being stepped down by power transformer, T1001, AC power is applied to rectifiers CR110 and CR100 and to a second transformer, T1002. This second transformer is used exclusively to power analog circuits and is included to maintain common mode currents lower than 50nA P-P.

6.6.3 +7V Unregulated and Analog Output Supplies

The +7V supply provides an unregulated voltage for the +5V regulator on the digital board. CR100 provides rectification for this supply, while C137 filters the supply.

The $\pm 5V$ supplies power to the analog output circuits also located on the digital board. CR110 rectifies the incoming AC, while U135 and U138 regulate the supply voltages to $\pm 5V$. Capacitors C149, C151, C153, and C154 provide filtering.

6.6.4 Analog Supplies

The three analog supplies include the $\pm 40V$, $\pm 15V$, and +5V supplies. The $\pm 40V$ supplies are used for the protection circuits, the +5V supply powers the digital circuits located in the analog section, while the $\pm 15V$ supplies power the bulk of the analog circuits. Note that all three supplies include an RC network across the respective transformer secondaries for noise suppression.

$\pm 40V$ Supplies

Rectification for the $\pm 40V$ supplies is performed by CR109, while input filter is done by C150 and C152. Supply regulation is performed by U137 and U140 and associated components. VR109 and VR110 protect the regulators in over voltage situations during power-up.

$\pm 15V$ Supplies

CR107 rectifies incoming AC for the $\pm 15V$ supplies, while C141 and C142 provide input filtering. U134 and U136 regulate the output voltages to $-15V$ and $+15V$ respectively, and C145 and C148 filter the regulator outputs.

+5V Supply

CR111 provides rectification, while U139 is the +5V regulator. Input and output filtering are performed by C138 and C155 respectively.

6.6.5 Reference Supplies

Stable +6.95V and +2.1V reference voltages are generated by U109, U113, and associated components. The +2.1V signal is used as a reference voltage by the A/D converter during its measurement cycle. The +6.95V signal is used by other analog circuits to derive stable +5V and $-10V$ reference signals.

U109 is a highly-stable, temperature-controlled zener reference. U113 and R188 provide a stable, constant current to minimize reference voltage variations. The +6.95V source is divided by R113 and R130 to obtain the final +2.1V value.

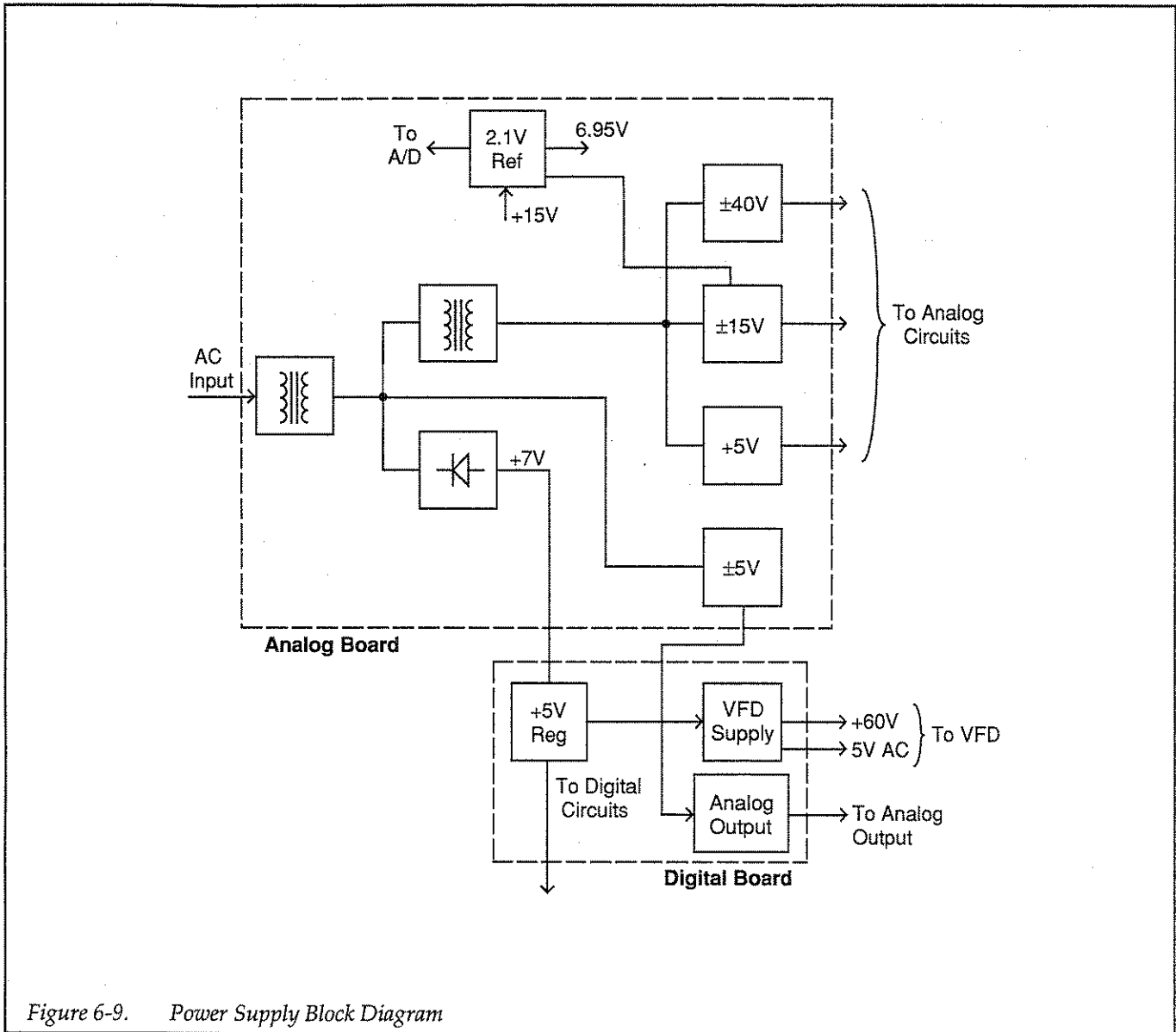

Figure 6-9. Power Supply Block Diagram

6.6.6 Digital Board Regulator and VFD Supplies

The +7V supply voltage applied to the digital board is regulated to +5V by U514. This supply voltage is used to power most of the circuits on the digital board. Output filtering for U514 is provided by C535.

U535 supplies the +60VDC and 5VAC voltages required by the VFD module. VR500, R527, and R528 provide reference regulation for U535.

