

Model 1973/1972 IEEE-488 Interface

Instruction Manual

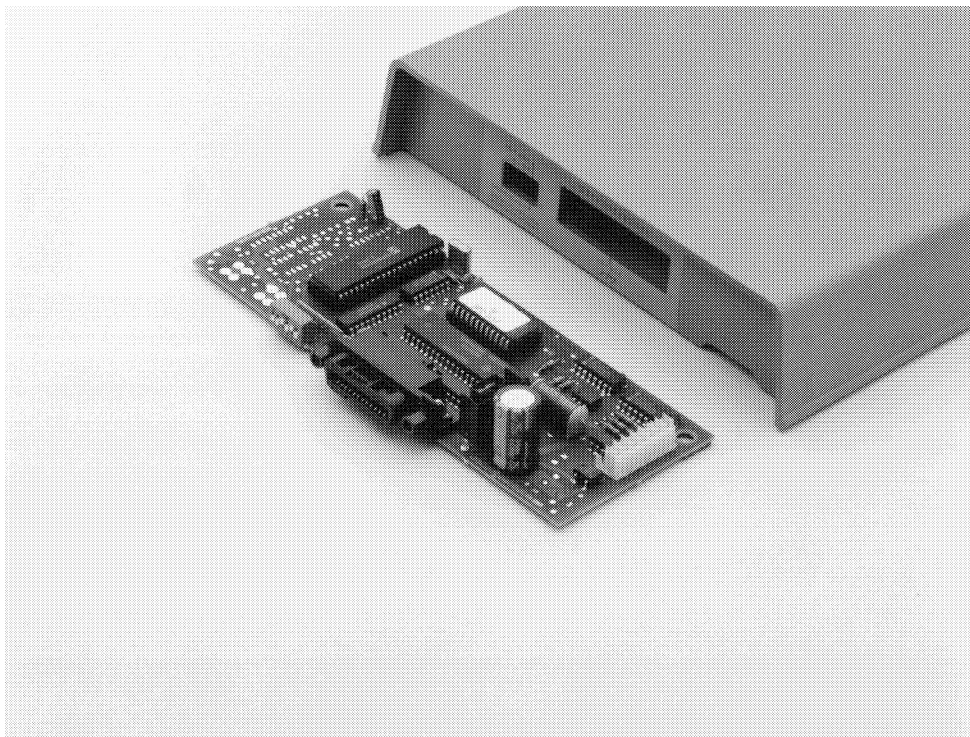

Contains Operating and Servicing Information

KEITHLEY

WARRANTY

Keithley Instruments, Inc. warrants this product to be free from defects in material and workmanship for a period of 1 year from date of shipment.

Keithley Instruments, Inc. warrants the following items for 90 days from the date of shipment: probes, cables, rechargeable batteries, diskettes, and documentation.

During the warranty period, we will, at our option, either repair or replace any product that proves to be defective.

To exercise this warranty, write or call your local Keithley representative, or contact Keithley headquarters in Cleveland, Ohio. You will be given prompt assistance and return instructions. Send the product, transportation prepaid, to the indicated service facility. Repairs will be made and the product returned, transportation prepaid. Repaired or replaced products are warranted for the balance of the original warranty period, or at least 90 days.

LIMITATION OF WARRANTY

This warranty does not apply to defects resulting from product modification without Keithley's express written consent, or misuse of any product or part. This warranty also does not apply to fuses, software, non-rechargeable batteries, damage from battery leakage, or problems arising from normal wear or failure to follow instructions.

THIS WARRANTY IS IN LIEU OF ALL OTHER WARRANTIES, EXPRESSED OR IMPLIED, INCLUDING ANY IMPLIED WARRANTY OF MERCHANTABILITY OR FITNESS FOR A PARTICULAR USE. THE REMEDIES PROVIDED HEREIN ARE BUYER'S SOLE AND EXCLUSIVE REMEDIES.

NEITHER KEITHLEY INSTRUMENTS, INC. NOR ANY OF ITS EMPLOYEES SHALL BE LIABLE FOR ANY DIRECT, INDIRECT, SPECIAL, INCIDENTAL OR CONSEQUENTIAL DAMAGES ARISING OUT OF THE USE OF ITS INSTRUMENTS AND SOFTWARE EVEN IF KEITHLEY INSTRUMENTS, INC., HAS BEEN ADVISED IN ADVANCE OF THE POSSIBILITY OF SUCH DAMAGES. SUCH EXCLUDED DAMAGES SHALL INCLUDE, BUT ARE NOT LIMITED TO: COSTS OF REMOVAL AND INSTALLATION, LOSSES SUSTAINED AS THE RESULT OF INJURY TO ANY PERSON, OR DAMAGE TO PROPERTY.



Keithley Instruments, Inc. • 28775 Aurora Road • Cleveland, OH 44139 • 440-248-0400 • Fax: 440-248-6168 • <http://www.keithley.com>

BELGIUM:	Keithley Instruments B.V.	Bergensesteenweg 709 • B-1600 Sint-Pieters-Leeuw • 02/363 00 40 • Fax: 02/363 00 64
CHINA:	Keithley Instruments China	Yuan Chen Xin Building, Room 705 • 12 Yumin Road, Dewai, Madian • Beijing 100029 • 8610-62022886 • Fax: 8610-62022892
FRANCE:	Keithley Instruments Sarl	B.P. 60 • 3, allée des Garays • 91122 Palaiseau Cédex • 01 64 53 20 20 • Fax: 01 60 11 77 26
GERMANY:	Keithley Instruments GmbH	Landsberger Strasse 65 • D-82110 Germering • 089/84 93 07-40 • Fax: 089/84 93 07-34
GREAT BRITAIN:	Keithley Instruments Ltd	The Minster • 58 Portman Road • Reading, Berkshire RG30 1EA • 0118-9 57 56 66 • Fax: 0118-9 59 64 69
INDIA:	Keithley Instruments GmbH	Flat 2B, WILOCRISSA • 14, Rest House Crescent • Bangalore 560 001 • 91-80-509-1320/21 • Fax: 91-80-509-1322
ITALY:	Keithley Instruments s.r.l.	Viale S. Gimignano, 38 • 20146 Milano • 02/48 30 30 08 • Fax: 02/48 30 22 74
NETHERLANDS:	Keithley Instruments B.V.	Postbus 559 • 4200 AN Gorinchem • 0183-635333 • Fax: 0183-630821
SWITZERLAND:	Keithley Instruments SA	Kriesbachstrasse 4 • 8600 Dübendorf • 01-821 94 44 • Fax: 01-820 30 81
TAIWAN:	Keithley Instruments Taiwan	1 Fl. 85 Po Ai Street • Hsinchu, Taiwan, R.O.C. • 886-3572-9077 • Fax: 886-3572-9031

Model 1973/1972 IEEE-488 Interface Instruction Manual

Throughout the manual, references to the Model 197 also refer to the Model 197A; references to the Models 1973 and 1972 also refer to the Models 1973A and 1972A respectively.

© 1991, Keithley Instruments, Inc.
Test Instrumentation Group
All rights reserved.
Cleveland, Ohio, U.S.A.
Third Printing 1991
Document Number: 1973-901-01 Rev. C

Safety Precautions

The following safety precautions should be observed before using this product and any associated instrumentation. Although some instruments and accessories would normally be used with non-hazardous voltages, there are situations where hazardous conditions may be present.

This product is intended for use by qualified personnel who recognize shock hazards and are familiar with the safety precautions required to avoid possible injury. Read the operating information carefully before using the product.

Exercise extreme caution when a shock hazard is present. Lethal voltage may be present on cable connector jacks or test fixtures. The American National Standards Institute (ANSI) states that a shock hazard exists when voltage levels greater than 30V RMS, 42.4V peak, or 60VDC are present. **A good safety practice is to expect that hazardous voltage is present in any unknown circuit before measuring.**

Before operating an instrument, make sure the line cord is connected to a properly grounded power receptacle. Inspect the connecting cables, test leads, and jumpers for possible wear, cracks, or breaks before each use.

For maximum safety, do not touch the product, test cables, or any other instruments while power is applied to the circuit under test. ALWAYS remove power from the entire test system and discharge any capacitors before: connecting or disconnecting cables or jumpers, installing or removing switching cards, or making internal changes, such as installing or removing jumpers.

Do not touch any object that could provide a current path to the common side of the circuit under test or power line (earth) ground. Always make measurements with dry hands while standing on a dry, insulated surface capable of withstanding the voltage being measured.

Do not exceed the maximum signal levels of the instruments and accessories, as defined in the specifications and operating information, and as shown on the instrument or test fixture rear panel, or switching card.

Do not connect switching cards directly to unlimited power circuits. They are intended to be used with impedance limited sources. NEVER connect switching cards directly to AC main. When connecting sources to switching cards, install protective devices to limit fault current and voltage to the card.

When fuses are used in a product, replace with same type and rating for continued protection against fire hazard.

Chassis connections must only be used as shield connections for measuring circuits, NOT as safety earth ground connections.

If you are using a test fixture, keep the lid closed while power is applied to the device under test. Safe operation requires the use of a lid interlock.

SPECIFICATIONS

IEEE OUTPUT (Options 1972 and 1973)

Accuracy:

The Model 197 accuracy specifications apply to the instrument if either of the following two conditions are met:

1. Factory Installation—The Model 1972/3 is installed at the factory.
2. Field Installation—When installed in the field, the instrument must be calibrated and operated with the Model 1972/3.

If instrument is operated without recalibration after field installation of Model 1972 or 1973, add to one year accuracy specifications:

DCV: add 0.004%

ACV: add 0.1%

OHMS: add 0.0075%

Warmup: 1 hour to rated accuracy.

Maximum Common-Mode Volt-Hertz Product: 1×10^6

Output:

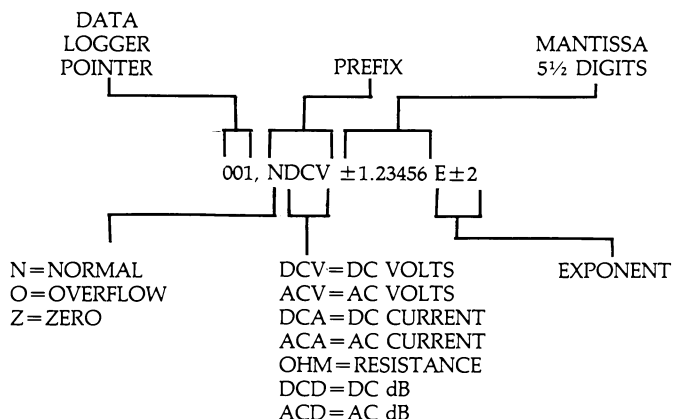

Time from Trigger to Reading Done:

T1, T3: 500ms (650ms in Ohms) typical

T5: 400ms (550ms in Ohms) typical

Address Modes: Talk Only, Addressable

ANALOG/IEEE OUTPUT (Model 1972 Option)

Accuracy: $\pm(0.25\%$ of displayed reading + 2mV).

In X1000, 2mV output = 0.2 displayed counts.

Response Time: Follows displayed conversion rate.

Level: 1V = 100,000 counts on X1 gain.

1V = 100 counts on X1000 gain.

Maximum output voltage = 4V.

Output Resistance: 1000Ω.

Isolation: 500V peak, input LO to output LO.

30V peak, output LO to earth ground.

IEEE-488 BUS IMPLEMENTATION

Multiline Commands: DCL, SDC, GET, GTL, UNT, UNL, SPE, SPD.

Uniline Commands: IFC, REN, EOI, SRQ, ATN.

Interface Functions: SH1, AH1, T5, TE0, L4, LE0, SR1, RL0, PP0, DC1, DT1, C0, E1.

Programmable Parameters: Range, REL, dB, EOI, Trigger, Calibration, SRQ, Status, Data Format, Terminator, Data Logger Retrieval.

Device-Dependent Commands:

dB:

D0 = dB off

D1 = dB on

Range: (Amps function not programmable but status word reflects the codes shown.)

	Volts	Ohms	Amps
R0	Auto	Auto	
R1	200m	200	200μ
R2	2	2k	2m
R3	20	20k	20m
R4	200	200k	200m
R5	2000	2M, 20M, 200M	2000m
R6			10A

Relative:

Z0 = REL off

Z1 = REL on

Trigger:

T0 = Continuous on Talk

T1 = One-shot on Talk

T2 = Continuous on GET

T3 = One-shot on GET

T4 = Continuous on X

T5 = One-shot on X

Execute:

X=Execute other device-dependent commands.

EOI:

K0 = EOI Enabled

K1 = EOI Disable

Status Word:

U0 = Output status word.

Data Format:

G0 = Readings and status word with prefix.

G1 = Readings and status word without prefix.

Data Logger:

B0 = Sends Display Readings

B1 = Sends stored Readings (Analog output reflects recalled reading)

SRQ:

M0 = Clear SRQ Data Mask

M1 = Reading Overflow

M8 = Reading Done

M9 = Reading Done or Reading Overflow

M16 = Busy

M17 = Busy or Reading Overflow

M24 = Busy or Reading Done

M25 = Busy, Reading Done or Reading Overflow

M32 = Clear SRQ Error Mask

M33 = IDDCO

M34 = IDDC

M35 = IDDC or IDDCO

M36 = Not in Remote

M37 = Not in Remote or IDDCO

M38 = Not in Remote or IDDC

M39 = Not in Remote, IDDC or IDDCO

Digital Calibration:

$V \pm n.nnnnnE \pm nn$ = enter calibration value.

Store:

L0 = Store calibration constants.

Terminator:

Y(ASCII) = ASCII Character

Y(LF) = CR LF

Y(CR) = LF CR

Y(DEL) = None

Specifications subject to change without notice.

TABLE OF CONTENTS

SECTION 1—GENERAL INFORMATION

1.1	Introduction	1-1
1.2	Interface Features	1-1
1.3	Warranty Information	1-1
1.4	Manual Addenda	1-1
1.5	Safety Symbols and Terms	1-1
1.6	Using the Instruction Manual	1-1
1.7	Specifications	1-2
1.8	Unpacking and Inspection	1-2

SECTION 2—AN OVERVIEW OF THE IEEE-488 BUS

2.1	Introduction	2-1
2.2	Bus Description	2-1
2.3	IEEE-488 Bus Lines	2-1
2.3.1	Bus Management Lines	2-1
2.3.2	Handshake Lines	2-2
2.3.3	Data Lines	2-3
2.4	Bus Commands	2-3
2.4.1	Uniline Commands	2-3
2.4.2	Universal Commands	2-3
2.4.3	Addressed Commands	2-4
2.4.4	Unaddressed Commands	2-4
2.4.5	Device-Dependent Commands	2-4
2.5	Command Codes	2-4
2.6	Command Sequences	2-4
2.6.1	Addressed Command Sequence	2-6
2.6.2	Universal Command Sequence	2-6
2.6.3	Device-Dependent Command Sequence	2-6

SECTION 3—SYSTEM CONFIGURATION

3.1	Introduction	3-1
3.2	Hardware Consideration	3-1
3.2.1	Typical Systems	3-1
3.2.2	Bus Connections	3-1
3.2.3	Primary Address Selection	3-3
3.3	Software Considerations	3-4
3.3.1	Controller Interface Routines	3-4
3.3.2	HP-85 BASIC Statements	3-4
3.3.3	Interface Functions Codes	3-5
3.3.4	Interface Commands	3-6

SECTION 4—OPERATION

4.1	Introduction	4-1
4.2	General Bus Commands	4-1
4.2.1	REN (Remote Enable)	4-1
4.2.2	IFC (Interface Clear)	4-2
4.2.3	GTL (Go To Local)	4-2
4.2.4	DCL (Device Clear)	4-2
4.2.5	SDC (Selective Device Clear)	4-2
4.2.6	Serial Polling (SPE, SPD)	4-3
4.3	Device-dependent Command Programming	4-3
4.3.1	Execute (X)	4-4
4.3.2	dB (D)	4-4
4.3.3	Range (R)	4-4
4.3.4	Relative (Z)	4-6
4.3.5	Triggering (T)	4-6
4.3.6	EOI (K)	4-6
4.3.7	Status Word (U)	4-7
4.3.8	SRQ Mode (M) and Status Byte Format	4-7
4.3.9	Data Format	4-10
4.3.10	Prefix (G)	4-10
4.3.11	Programmable Terminator (Y)	4-11
4.3.12	Buffer (B)	4-11
4.3.13	Digital Calibrator (V) and Storage (L)	4-12
4.4	Talk Only Operation	4-12

SECTION 5—ANALOG OUTPUT (Model 1972 only)

5.1	Introduction	5-1
5.2	Using Analog Output	5-1
5.3	Output Resistance	5-3
5.4	X1000 Mode Resolution and Accuracy	5-3

SECTION 6—THEORY OF OPERATION

6.1	Introduction	6-1
6.2	Circuit Description	6-1
6.2.1	Power Supply	6-1
6.2.2	Digital Circuitry	6-2
6.2.3	Analog Output (Model 1972 only)	6-2

SECTION 7—MAINTENANCE

7.1	Introduction	7-1
7.2	Installation	7-1
7.3	Calibration (Model 1972 only)	7-1
7.3.1	Warm Up	7-1
7.3.2	Recommended Calibration Equipment	7-3
7.3.3	Environmental Conditions	7-3
7.3.4	Calibration	7-3
7.4	Special Handling of Static Sensitive Devices	7-3
7.5	Troubleshooting	7-3

SECTION 8—REPLACEABLE PARTS

8.1 Introduction 8-1
8.2 Replaceable Parts 8-1
8.3 Ordering Information 8-1
8.4 Factory Service 8-1
8.5 Schematic Diagrams and Component Location Drawings 8-1

LIST OF TABLES

Table	Title	Page
2-1	IEEE-488 Bus Command Summary	2-6
2-2	Hexadecimal and Decimal Command Codes	2-6
2-3	Typical Addressed Command Sequence	2-7
2-4	Typical Device-Dependent Command Sequence	2-7
3-1	IEEE Contact Designation	3-2
3-2	Primary Address Switch Positions	3-4
3-3	HP-85 IEEE-488 BASIC Statement	3-5
3-4	Interface Function Codes	3-6
3-5	IEEE Command Groups	3-6
4-1	General Bus Commands	4-1
4-2	Default Values (Status Upon Power Up or After SDC or DCL)	4-3
4-3	Device-Dependent Command Summary	4-5
4-4	Range Commands	4-6
4-5	SRQ Mask Commands	4-9
4-6	Status Byte and Mask Interpretation	4-10
5-1	Analog Output Parameters (V)	5-2
5-2	Analog Output Parameters (Ω)	5-2
5-3	Analog Output Parameters (I)	5-2
5-4	Analog Output Parameters (dB)	5-3
7-1	Static Sensitive Devices	7-3
7-2	Model 1972 Interface Checks	7-4
7-3	Model 1973 Interface Checks	7-5
8-1	Model 1973 Parts List	8-2
8-2	Model 1972 Parts List	8-3

LIST OF ILLUSTRATIONS

Figure	Title	Page
2-1	IEEE Bus Configuration	2-2
2-2	Handshake Sequence	2-3
2-3	Command Codes	2-5
3-1	System Types	3-1
3-2	IEEE-488 Connector	3-1
3-3	IEEE-488 Connections	3-2
3-4	Contact Assignments	3-2
3-5	Rear Panel of Model 197 Showing IEEE Connections and Switches	3-3
3-6	Typical IEEE-488 Bus Driver (One of 16)	3-3
3-7	Primary Address Switches (Address 20 Shown)	3-4
4-1	General Format for U0 Command	4-8
4-2	Status Byte Format	4-10
4-3	Data Format	4-10
5-1	Analog Output Connections	5-1
5-2	X1000 Analog Output	5-2
6-1	Simplified Block Diagram	6-1
6-2	Memory Map	6-2
6-3	X1 and X1000 Gains	6-2
7-1	Model 1973 Installation	7-1
8-1	Model 1973, Component Location Drawing, Dwg. No. 1973-100	8-5
8-2	Model 1972, Component Location Drawing, Dwg. No. 1972-100	8-7
8-3	Model 1973, Schematic Diagram, Dwg. No. 1973-106	8-9
8-4	Model 1972, Schematic Diagram, Dwg. No. 1972-106	8-11

SECTION 1

GENERAL INFORMATION

1.1 INTRODUCTION

The Model 1973 is an IEEE-488 interface for the Model 197 Autoranging Microvolt DMM. This interface adds extra versatility to the Model 197 by allowing the transmission of data and commands over the IEEE-488 bus. The interface provides all the necessary logic to interface the Model 197 to the bus using standard IEEE-488-1973 protocol.

The Model 1972 is an IEEE-488 interface that is very similar to the Model 1973. In fact, the only difference between the two interfaces is that the Model 1972 includes an Analog Output and the Model 1973 does not.

Since the only difference between the two interface is the analog output, the Model 1973 is referred to throughout the manual. Section 5 and 6 contain information concerning the analog output of the Model 1972. All the rest of the information pertaining the Model 1973 also relates the Model 1972. The analog output specifications precede the Table of Contents.

The Model 1973/1972 IEEE-488 Instruction Manual covers the following IEEE-488 interface options:

- Model 1973 IEEE-488 Interface (for the Model 197)
- Model 1973A IEEE-488 Interface (for the Model 197A)
- Model 1972 IEEE-488 Interface (for the Model 197)
- Model 1972A IEEE-488 Interface (for the Model 197A)

1.2 INTERFACE FEATURES

Important IEEE-488 interface features include:

- With the Model 1973 installed, the Model 197 is able to communicate with other instrumentation using the same IEEE-488-1978 standards.
- Standard IEEE connector that provides easy connection to the IEEE-488 bus.
- The primary address of the Model 197/1973 may be easily changed by using the five address switches on the rear panel of the instrument.

- All Model 197 operation is supported by IEEE programming. In addition, numerous other IEEE commands add operating features not available from the front panel.

1.3 WARRANTY INFORMATION

Warranty information may be found on the inside front cover of this manual. Should it become necessary to exercise the warranty, contact your Keithley representative or the factory to determine the proper course of action. Keithley Instruments Inc. maintains service facilities in the United States, United Kingdom and throughout Europe. Addresses for these facilities may be found inside the front cover of this manual. Information concerning the application, operation or service of your instrument may be directed to the applications engineer at any of these locations.

1.4 MANUAL ADDENDA

Information concerning improvements or changes to the instrument which occur after the printing of this manual may be found on an addendum included with this manual. Be sure to review these changes before attempting to program the instrument.

1.5 SAFETY SYMBOLS AND TERMS

The following safety symbols and terms are used in this manual and may be found on the instrument.

The symbol  on the instrument indicates that the user should refer to the operating instructions.

The symbol  on the instrument indicates that a potential of 1000V or more may be present on the terminals. Standard safety precautions should be observed when such dangerous voltage levels are encountered.

Information associated with the **WARNING** heading explains dangers that could result in personal injury or death.

Information following the **CAUTION** heading explains hazards that could damage the instrument.

1.6 USING THE INSTRUCTION MANUAL

This manual contains all information necessary to connect the Model 1973 to the IEEE-488 bus and program the instrument from a separate bus controller.

The manual is divided into the following sections:

1. Section 2 contains a general description of the IEEE-488 bus and its commands.
2. Section 3 contains information necessary to connect the instrument to the bus and set the primary address.
3. The bulk of the programming information may be found in section 4. General bus command as well as commands unique to the Model 1973 are covered in detail.
4. Section 5 contains maintenance information such as installation and troubleshooting.
5. Section 6 contains replaceable parts information.

1.7 SPECIFICATIONS

A complete list of IEEE specifications can be found preceding this section.

1.8 UNPACKING AND INSPECTION

The Model 1973 interface was carefully inspected both mechanically and electrically before shipment. Upon receiving the Model 1973, carefully unpack all items and check for any obvious physical damage that may have occurred during shipment. Report any damage to the shipping agent immediately. Retain and use the original packing material in case reshipment is necessary. The following items are shipped with every Model 1973 order:

Model 1973 IEEE-488 Interface
Hardware necessary for installation.
Model 1973 Instruction Manual
Additional accessories as ordered.

If an additional manual is required, order the manual package (Keithley part number 1973-901-00). The manual package includes an instruction manual and all pertinent addenda.

SECTION 2

AN OVERVIEW OF THE IEEE-488 BUS

2.1 INTRODUCTION

The IEEE bus is an instrumentation data bus adopted by the IEEE (Institute of Electrical and Electronic Engineers) in 1975 and given the IEEE-488 designation. The most recent revision of bus standards was made in 1978; hence the complete description for current bus standards is the IEEE-488-1978 designation.

This section gives a brief description of the general bus structure along with an outline of bus commands. The information presented here is not intended to be an in-depth description of what is truly a very complex set of standards. More complete information on the IEEE-488 bus which is frequently referred to as the General Purpose Interface Bus (GPIB) is available from the IEEE and a variety of other sources.

2.2 BUS DESCRIPTION

The IEEE-488 bus was designed as a parallel data transfer medium to optimize data transfer without using an excessive number of bus lines. In keeping with goal, the bus has only eight data lines that are for both data and some commands. Five bus management lines and three handshake lines round out the complement of signal lines. Since the bus is of parallel design, all devices connected to the bus have the same information available simultaneously. Exactly what is done with the information by each device depends on many factors, including device capabilities.

A typical bus configuration for controlled operation is shown in Figure 2-1. The typical system shown will have one controller and one or more instruments to which the commands are given and in most cases from which the data is received. Generally, there are three categories that describe device operation. These designations include: controller; talker and listener.

The controller does what its name implies; it controls other devices on the bus. A talker sends data; while a listener receives data. Depending on the instrument, a particular device may be a talker only or both a talker and a listener.

Any given system can have only one controller (control may be passed to an appropriate device through a special command), but any number of talkers and listeners may be pre-

sent up to the hardware constraints of the bus. Generally, the bus is limited to 15 devices, but this number may be reduced if higher than normal data transfer rates are required or if longer than normal cables are used.

Several devices may be connected to listen at once, but only one device may be a talker at any given time. Otherwise, communications would be garbled much like trying to pick out a single conversation in a large crowd.

Before a device can be a talker or a listener it must be appropriately addressed. Devices are selected on the basis of their primary address; the addressed device is sent a talk or listen command derived from its primary address. Normally, each device on the bus has a unique address so that each may be addressed individually.

Once each device is addressed to talk or listen, appropriate bus transactions are set to take place. For example, if an instrument is addressed to talk, it will usually place its data on the bus one byte at a time. The listening device will read this information and the appropriate software can then be used to channel the information to the desired location.

2.3 IEEE-488 BUS LINES

The signal lines on the IEEE-488 bus lines are grouped into three general categories. The data lines handle bus information, while the handshake and bus management lines ensure that proper data transfer and bus operation take place. Each of these bus lines is active low so that approximately zero volts is a logic one. The following paragraphs describe the purpose of these lines which are shown in Figure 2-1.

2.3.1 Bus Management Lines

The bus management group is made up of five signal lines that help ensure an orderly transfer of data. These lines are used to send the uniline commands described in paragraph 2.4.

ATN (Attention)—The ATN line is one of the more important management lines. The state of the ATN line determines whether controller information on the data bus is to be considered data or a multiline command as described in paragraph 2.4.

IFC (Interface Clear)—Setting the IFC line true (low) causes the bus to go to a known state by sending the IFC command.

REN (Remote Enable)—Setting the REN line low sends the REN command. This sets up instruments on the bus for remote operation.

EOI (End Or Identify)—The EOI line is used to send the EOI command that usually terminates a multi-byte transfer sequence.

SRQ (Serive Request)—The SRQ line is set low by a device when it requires service from the controller.

2.3.2 Handshake Lines

The bus uses three handshake lines that operate in an interlocked sequence. This method ensures reliable data transfer regardless of the transfer rate. Generally, data transfer occurs at a rate determined by the slowest active device on the bus.

One of the handshake lines is controlled by the data source, while the remaining two lines are controlled by the accepting device. The three bus handshake lines are:

DAV (Data Valid)—The source controls the state of the DAV line.

NRFD (Not Ready For Data)—The acceptor controls the states of the NRFD line.

NDAC (Not Data Accepted)—The acceptor controls the state of the NDAC line.

The complete handshake sequence for one data byte is shown in Figure 2-2. Once data is on the bus, the source checks to see that NRFD is high, indicating that all devices on the bus are ready for data. At the same time NDAC should be low from the previous byte transfer. If these conditions are not met, the source must then wait until the NRFD and NDAC lines have the correct status. If the source is a controller, NRFD and NDAC must remain stable for at least 100nsec after ATN is low. Because of the possibility of bus hang up, some controllers have time out routines to display error messages if the handshake sequence stops for any reason.

Once the NRFD and NDAC lines are properly set, the source sets the DAV line low, indicating that data on the bus is now valid. The NRFD line then goes low; the NDAC line goes high once all the devices on the bus have accepted the data. Each device will release the NDAC line at its own rate, but the NDAC line will not go high until the slowest device has accepted the data byte.

After the NDAC line goes high, the source then sets the DAV line high to indicate that the data on the bus is no longer valid. At this point, the NDAC line returns to its low state. Finally, the NRFD line is released by each of the devices at their own rate, until the NRFD line finally goes high when the slowest device is ready and the bus is set to repeat the sequence with the next data byte.

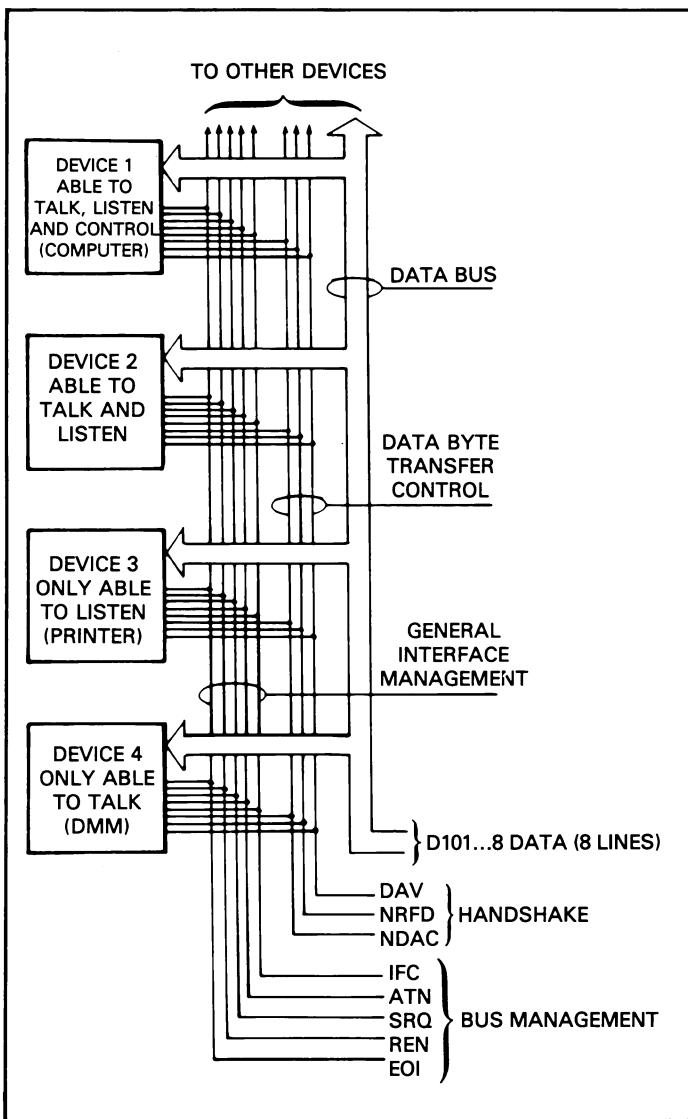

Figure 2-1. IEEE Bus Configuration

2.3.3 Data Lines

The IEEE-488 bus uses the eight data lines that allow data to be transmitted and received in a bit-parallel, byte-serial manner. The eight lines use the convention DI01 through DI08 instead of the more common D0 through D7 binary terminology. The data lines are bidirectional and, as with the remaining bus signal lines, low is true.

2.4 BUS COMMANDS

While the hardware aspect of the bus is essential, the interface would be essentially worthless without the appropriate commands to control communications between the various instruments on the bus. This section briefly describes the purpose of the bus commands, which are grouped into the three general categories:

Uniline Commands—Sent by setting the associated bus line low.

Multiline Commands—General bus commands which are sent over the data lines with the ATN line low.

Device-dependent Commands—Special commands that depend on device configuration; sent over the data lines with ATN high.

2.4.1 Uniline Commands

Uniline commands are sent by setting the associated bus line low. The ATN, IFC and REN commands are asserted only by the system controller. The SRQ command is sent by either the controller or an external device depending on the direction of data transfer. The following is a brief description of each command.

REN (Remote Enable)—When the controller sends the REN command, the instrument will be set up for remote operation. Generally, the REN command should be sent before attempting to program the instruments over the bus.

EOI (End Or Identify)—The EOI command is used to positively identify the last byte in a multi-byte transfer sequence. This allows variable length data words to be transmitted easily.

IFC (Interface Clear)—The IFC command is sent to clear the bus and set devices to a known state. Although device configurations differ, the IFC command usually places instruments in the talk and listen idle states.

ATN (Attention)—The controller sets ATN true while transmitting addresses or multiline commands. Device-dependent commands are sent with the ATN line high (false).

SRQ (Service Request)—The SRQ command is asserted by an external device when it requires service from the controller. If more than one device is present, a serial polling sequence, as described in Section 4 must be used to determine which device has requested service.

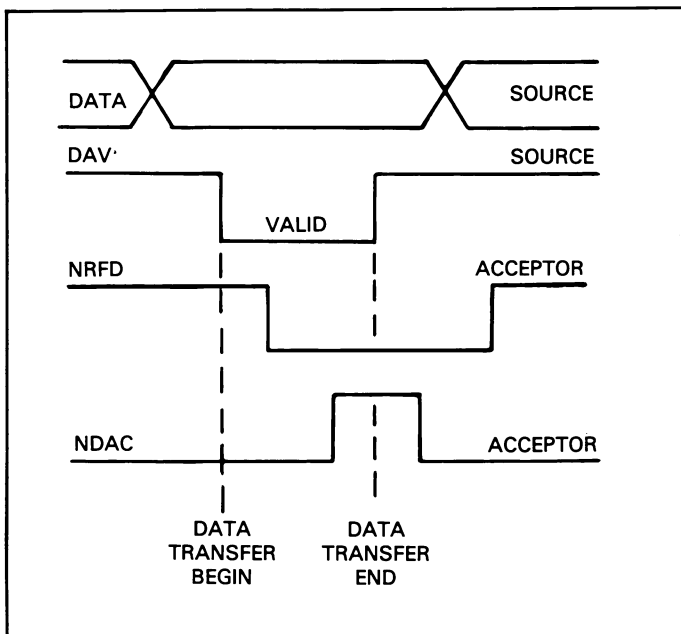

Figure 2-2. Handshake Sequence

2.4.2 Universal Commands

Universal commands are multiline commands that require no addressing. All instrumentation equipped to implement the command will do so simultaneously when the command is transmitted over the bus. As with all multiline commands, the universal commands are sent over the data line with ATN low.

LLO (Local Lockout)—The LLO command is used to lock out front panel controls on devices so equipped.

DCL (Device Clear)—After a DCL is sent, instrumentation equipped to implement the commands will revert to a known state. Usually, instruments return to their power-up conditions.

SPE (Serial Poll Enable)—The SPE command is the first step in the serial polling sequence. The serial polling sequence is used to determine which instrument has requested service with the SRQ command.

SPD (Serial Poll Disable)—The SPD command is sent by the controller to remove all instrumentation from the serial poll mode.

2.4.3 Addressed Commands

Addressed commands are multiline commands that must be preceded by a listen command before the instrument will respond. The listen command is derived from the device's primary address. Only the addressed device will respond to each of these commands:

SDC (Selective Device Clear)—The SDC command performs essentially the same function as the DCL command. The difference is with the SDC command only the addressed device will respond. The addressed instrument usually returns to its default conditions when the SDC command is sent.

GTL (Go To Local)—The GTL command is used to remove instruments from the remote mode of operation. Also, front panel operation will usually be restored if the LLO command was previously sent.

GET (Group Execute Trigger)—The GET command is used to trigger devices to perform a specific action that depends on device configuration. Although GET is considered to be an addressed command, many devices respond to GET without being addressed.

2.4.4 Unaddressed Commands

The two unaddressed commands are used by the controller to remove all talkers and listeners from the bus simultaneously. ATN is low when these multiline commands are asserted.

UNL (Unlisten)—All listeners are removed from the bus at once when the UNL command is placed on the bus.

UNT (Untalk)—The controller sends the UNT command to clear the bus of any talkers.

2.4.5 Device-Dependent Commands

The meaning of the device-dependent commands is determined by instrument configuration. Generally, these commands are sent as one or more ASCII characters that tell the device to perform a specific function. For example, Z1 is sent to place the instrument in the relative mode. For complete information on using these commands with the Model 1973, refer to Section 4. The IEEE-488 bus treats device-dependent commands as data with the ATN line high (false) when the commands are transmitted.

2.5 COMMAND CODES

Each multiline command is given a unique code that is transmitted over the bus as 7 bit ASCII data. This section briefly explains the code groups which are summarized in Figure 2-3. Every command is sent with ATN low.

Addressed Command Group (ACG)—Addressed commands are listed in column 0(B) in Figure 2-3. Column 0(A) lists the corresponding ASCII codes.

Universal Command Group (UCG)—Columns 1(A) and 1(B) list the Universal commands and the corresponding ASCII codes.

Listen Address Group (LAG)—Columns 2(A) and 3(A) list the ASCII codes corresponding to the primary address listed in columns 2(B) and 3(B). For example, if the primary address is sent to 12, the LAG byte will correspond to an ASCII(,) command.

Talk Address Group (TAG)—TAG primary address values and the corresponding ASCII characters are listed in columns 4(A) through 5(B).

The preceding address groups are combined together to form the Primary Command Group (PCG). The bus also has another group of commands, called the Secondary Command Group (SCG). These are listed in Figure 2-3 for informational purposes only; the Model 1973 does not respond to these commands, but other devices may have secondary addressing capability.

NOTE

Commands are normally transmitted with the 7 bit code listed in Figure 2-3. For most devices, the condition of D₇ (DI08) is unimportant, as shown by the "Don't Care" indication in the table. Some devices, however, may require that D₇ assume a specific logic state before the commands are recognized.

Hexadecimal and decimal values for each of the commands or command groups are listed in Table 2-2. Each value in the table assumes that D₇ is set to 0.

2.6 COMMAND SEQUENCES

The proper command sequence must be sent by the controller before an instrument will respond as intended. The universal commands such as LLO and DCL, require only that ATN be set low before the command is sent. Other commands require that the device be addressed to listen first. This section briefly describes the bus sequence for several types of commands.

Table 2-1. IEEE-488 Bus Command Summary

Command Type	Command	State of ATN Line*	Comments	
Uniline	REN (Remote Enable)	X	Set up for remote operation.	
	EOI (End Or Identify)	X	Sent by setting EOI low.	
	IFC (Interface Clear)	X	Clear Interface.	
	ATN (Attention)	Low	Defines data bus contents.	
	SRQ (Service Request)	X	Controlled by external device.	
Multiline	Universal	DCL (Device Clear)	Low	Returns device to default conditions.
		SPE (Serial Poll Enable)	Low	Enables serial polling.
		SPD (Serial Poll Disable)	Low	Disables serial polling.
	Addressed	SDC (Selective Device Clear)	Low	Returns unit to default conditions.
		GTL (Go To Local)	Low	Returns to local control.
	Unaddressed	GET (Group Execute Trigger)	Low	Triggers device for reading.
		UNL (Unlisten)	Low	Removes all listeners from bus.
		UNT (Untalk)	Low	Removes all talkers from bus.
Device-dependent**		High	Programs Model 197 for various modes.	

*X = Don't Care

**See paragraph 4.3 for complete description.

Table 2-2. Hexadecimal and Decimal Command Codes

Command	Hex Value*	Decimal Value
GTL	01	1
SDC	04	4
GET	08	8
DCL	14	20
SPE	18	24
SPD	19	25
LAG	20-3F	32-63
TAG	40-5F	64-95
UNL	3F	63
UNT	5F	95

*Values shown with D₇ = 0.

2.6.1 Addressed Command Sequence

Before a device will respond to one of these commands, it must receive a LAG command derived from its primary address. Table 2-3 shows a typical sequence for the SDC command. The LAG command assumes that the instrument is set at a primary address of 20 (10100).

Note that an UNL command is transmitted before the LAG, SDC sequence. This is generally done to remove all other listeners from the bus first so that only the addressed device responds.

2.6.2 Universal Command Sequence

The universal commands are sent by setting ATN low and then placing the command byte on the bus. For example, the following gives the LLO command:

ATN•DCL

Note that both ATN and LLO are on the bus simultaneously. Also, addressing is not necessary.

2.6.3 Device-Dependent Command Sequence

Device-dependent commands are transmitted with ATN high. However, the device must be addressed to listen first before the command is transmitted. Table 2-4 shows the sequence for the following command:

Z1X

This command, which sets the Model 197/1973 to the relative mode, is described in detail in Section 4.

Table 2-3. Typical Addressed Command Sequence

Step	Command	ATN State	Data Bus		
			ASCII	Hex	Decimal
1	UNL	Set low	?	3F	63
2	LAG*	Stays low	4	34	52
3	SDC	Stays low	EOT	04	4
4		Returns high			

*Assumes primary address = 20.

Table 2-4. Typical Device-Dependent Command Sequence

Step	Command	ATN State	Data Bus		
			ASCII	Hex	Decimal
1	UNL	Set low	?	3F	63
2	LAG*	Stays low	4	34	52
3	Data	Set high	F	46	70
4	Data	Stays high	0	30	48
5	Data	Stays high	X	58	88

*Assumes primary address = 20.

SECTION 3 SYSTEM CONFIGURATION

3.1 INTRODUCTION

There are two operating aspects to almost any digital interface. The IEEE-488 is no exception of this rule. Not only must the hardware meet certain standards, but all devices, including the controller, must have appropriate software. This section deals with important hardware and software aspects of bus operation.

3.2 HARDWARE CONSIDERATION

Before the Model 1973 can be used with the IEEE-488 bus, the instrument must be connected to the bus with a suitable connector. Also, the primary address must be properly selected as described in this section. But most importantly, it should be installed in the Model 197. Refer to Section 5 for installation instructions.

3.2.1 Typical Systems

The IEEE-488 bus is a parallel interface system. As a result, adding more devices is simply a matter of using more cables to make the desired connections. Because of this flexibility, system complexity can range from the very simple to extremely complex.

Figure 3-1 shows two typical system configurations. Figure 3-1(A) shows the simplest possible controlled system. The controller is used to send commands to the instrument, which sends data back to the controller.

The system becomes more complex in Figure 3-1(B), where additional instrumentation is added. Depending on programming, all data may be routed through the controller, or it may be transmitted directly from one instrument to another. For very complex applications, a much larger computer can be used. Tape drives or disks can then be used to store data.

3.2.2 Bus Connections

The Model 1973 is connected to the bus through an IEEE-488 connector which is shown in Figure 3-2. This connector is designed to be stacked to allow a number of parallel connections to one instrument.

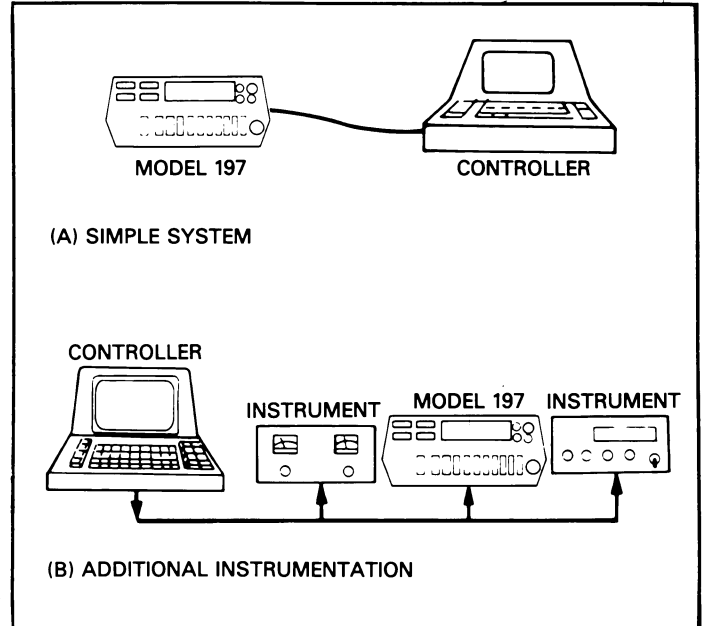

Figure 3-1. System Types

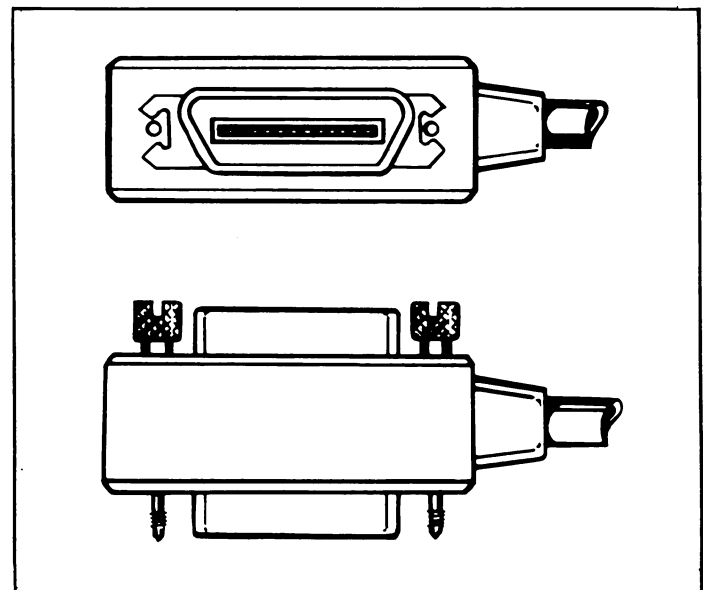

Figure 3-2. IEEE-488 Connector

NOTE

To avoid possible mechanical damage, it is recommended that not more than three connectors be stacked on any one instrument. Otherwise the resulting strain may cause internal damage.

A typical connecting scheme for the bus is shown in Figure 3-3. Each cable normally has the standard IEEE-488 connector on each end. The Keithley Model 7008-6 cable, which is six feet long, is ideal for this purpose. Once the connections are made, the screws should be securely tightened.

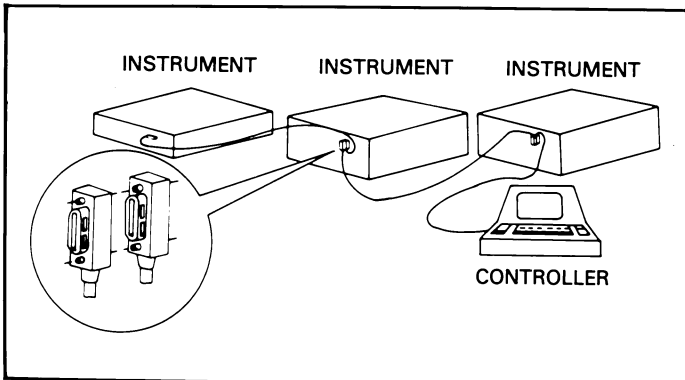

Figure 3-3. IEEE-488 Connections

NOTE

The IEEE-488 bus is limited to a maximum of 15 devices, including the controller. Also, the maximum cable length is 20 meters. Failure to observe these limits will probably result in erratic operation.

Custom cables may be constructed using the information in Table 3-1 and Figure 3-4. Table 3-1 lists the contact assignments for the various bus lines, while Figure 3-4 shows the contact designations. Contact 18 through 24 are return lines for the indicated signal lines. The cable shield is connected to contact 12. Each ground line is connected to digital common in the Model 1973, but contact 12 within the instrument is left unconnected to avoid ground loops. Refer to Figure 3-5 to locate the connector on the rear panel of the Model 197.

WARNING

The voltage between IEEE common and chassis ground must not exceed 30V or damage to the instrument may occur.

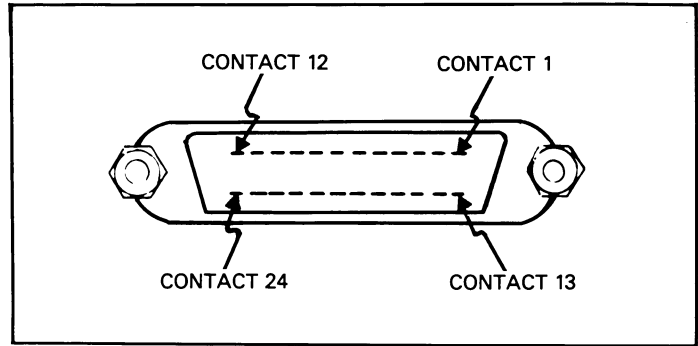

Figure 3-4. Contact Assignments

A typical signal line bus driver is shown in Figure 3-6. With the configuration shown, the driver has bidirectional capability. When the I/O control line is high, the line is configured as an output line. When the control line is low, the driver is set up for input operation. Note that not all signal lines have bidirectional capability. Some lines, such as ATN, will always be configured as an output line in the controller and as an input line for all other devices on the bus.

Table 3-1. IEEE Contact Designations

Contact Number	IEEE-488 Designation	Type
1	DIO1	Data
2	DIO2	Data
3	DIO3	Data
4	DIO4	Data
5	EOI (24)*	Management
6	DAV	Handshake
7	NRFD	Handshake
8	NDAC	Handshake
9	IFC	Management
10	SRQ	Management
11	ATN	Management
12	SHIELD	Ground
13	DIO5	Data
14	DIO6	Data
15	DIO7	Data
16	DIO8	Data
17	REN (24)*	Management
18	Gnd, (6)*	Ground
19	Gnd, (7)*	Ground
20	Gnd, (8)*	Ground
21	Gnd, (9)*	Ground
22	Gnd, (10)*	Ground
23	Gnd, (11)*	Ground
24	Gnd, LOGIC	Ground

*Numbers in parentheses refer to signal ground return of reference contact number. EOI and REN signal lines return on contact 24.

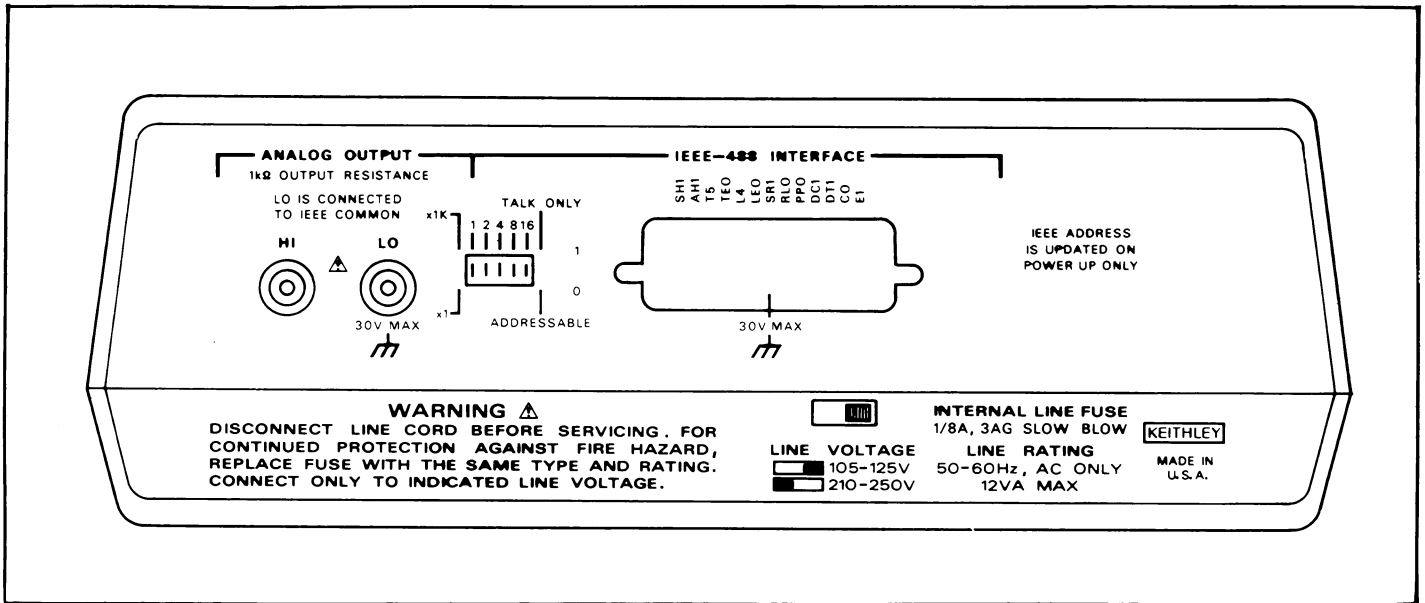

Figure 3-5. Rear Panel of Model 197 Showing IEEE Connections and Switches

3.2.3 Primary Address Selection

The Model 1973 must receive a listen command before it will respond to addressed commands. Similarly, the instrument must receive a talk command before it will transmit its data string, status word or status byte. These listen and talk commands are derived from the instrument's primary address. The Model 1973 is shipped from the factory with a primary address of 20 (10100). The primary address may be set to any value between 0 and 30 as long as address conflicts with other bus instruments are avoided. This may be done by placing the primary address switches, which are shown in Figure 3-7, in the desired position. Note that the primary address of the instrument must agree with the address specified in the controller's programming language.

NOTE

The primary address switch positions are read only upon power up. If the address is changed, the Model 197 must be turned off and then powered up again before the new address can be used.

Figure 3-7 shows the correct positions for the Model 1973 factory set value of 20 (10100). If a different address is required, the primary address may be changed as outlined in Table 3-2.

NOTE

If other instrumentation is also connected to the bus, be sure that each device has a different primary address. If this precaution is not observed, erratic bus operation will probably result.

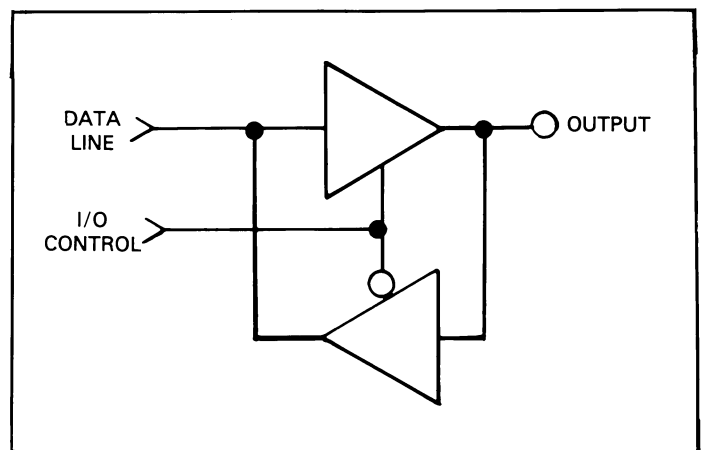

Figure 3-6. Typical IEEE-488 Bus Driver (One of 16)

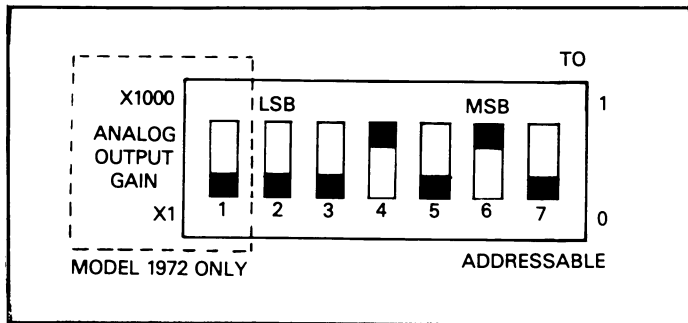

Figure 3-7. Primary Address Switches (Address 20 Shown)

The primary address switches are binary weighted; A1 is the least significant bit, while A5 is the most significant bit. For example, the binary value for the factory set primary address of 20 is 10100. Use the tip of a pencil to operate the switches.

Table 3-2. Primary Address Switch Positions

Primary Address	MSB 5	4	3	2	LSB 1
0	0	0	0	0	0
1	0	0	0	0	1
2	0	0	0	1	0
3	0	0	0	1	1
4	0	0	1	0	0
5	0	0	1	0	1
6	0	0	1	1	0
7	0	0	1	1	1
8	0	1	0	0	0
9	0	1	0	0	1
10	0	1	0	1	0
11	0	1	0	1	1
12	0	1	1	0	0
13	0	1	1	0	1
14	0	1	1	1	0
15	0	1	1	1	1
16	1	0	0	0	0
17	1	0	0	0	1
18	1	0	0	1	0
19	1	0	0	1	1
20	1	0	1	0	0
21	1	0	1	0	1
22	1	0	1	1	0
23	1	0	1	1	1
24	1	1	0	0	0
25	1	1	0	0	1
26	1	1	0	1	0
27	1	1	0	1	1
28	1	1	1	0	0
29	1	1	1	0	1
30	1	1	1	1	0

NOTE

Instruments should not be operated with a primary address of 31 (11111) even though it is possible to set the Model 1973 address to those positions. This address is reserved for the UNT and UNL commands; erratic operation may result if primary address 31 is used.

3.3 SOFTWARE CONSIDERATIONS

The most sophisticated computer in the world would be useless without the necessary software. This basic requirement is also true of the IEEE-488 bus, which requires the use of handler routines as described in this section.

3.3.1 Controller Interface Routines

Before a controller can be used with the IEEE-488 interface, the user must make certain that appropriate handler software is present within the controller. With the HP-85 computer, for example, the HP-85 interface card must be used with an additional I/O ROM, which contains the necessary handler software.

Other small computers that can be used as controllers have limited IEEE command capability. The PET/CBM computers, for example, are incapable of sending multiline commands from BASIC, although these commands can be sent through machine language routines. The capabilities of other small computers depends on the particular interface being used. Often, little software "tricks" are required to achieve the desired results.

From the preceding discussion the message is clear; make sure the proper software is being used with the interface. Often, the user may incorrectly suspect that a hardware problem is causing fault when it was the software that was causing the problem all along.

3.3.2 HP-85 BASIC Statements

Many of the programming instructions covered in Section 4 use examples written in Hewlett Packard Model 85 BASIC. The HP-85 was chosen for these examples because it has a large number of BASIC statements that control IEEE-488 operation. This selection covers those HP-85 BASIC statements that are essential to Model 197/1973 operation.

A complete list of HP-85 BASIC statements is shown in Table 3-3. All the statements in the table have a one or three digit argument that must be specified. The first digit is the HP-85 interface select code which is set to 7 at the factory. The last two digits of those statements that require a three digit argument specify primary address. Generally, only those commands that actually require an address to be sent over the bus require that the primary address be specified in the BASIC statement.

Those statements in the table with three digit arguments assume that the primary address of the device is set at 20. Other primary addresses require that the last two digits be set to the corresponding value. For example, to send a GTL command to device 20, the following BASIC statement would be used:

LOCAL 720

Some of the statements in the table have two forms; the exact configuration used depends on the desired command. For example, CLEAR 7 will cause a DCL to be sent, CLEAR 720 causes an SDC to be transmitted to device 20.

The third column of Table 3-3 lists the mnemonics for the command sequences. While most of these are covered elsewhere, a couple of points should be noted. As described earlier, the ATN line is set low by the controller if the data bus contains a multiline command. This is indicated in the table by ANDing the ATN mnemonic with the first command on the bus. For example, ATN GET means that ATN and GET are sent simultaneously.

Two commands not previously covered are MTA (My Talk Address) and MLA (My Listen Address). These are ordinary PCG (Primary Command Group) addresses sent by the HP-85 to facilitate bus operation in certain circumstances.

NOTE

The HP-85 address is set to 21 at the factory. Since each device on the bus must have a unique primary address, do not set the Model 1973 to the controller's address to avoid conflicts.

3.3.3 Interface Function Codes

The interface function codes are part of the IEEE-488-1978 standards. These codes define an instrument's ability to support various functions and should not be confused with programming commands found elsewhere in this manual.

Table 3-4 lists the codes for the Model 1973. These codes are also listed for convenience on the rear panel of the instrument immediately above the IEEE connector. The numeric value following each one or two letter codes defines Model 1973 capabilities as follows:

SH (Source Handshake Function)—The ability for the Model 1973 to initiate the transfer of message/data on the data bus is provided by the SH function.

Table 3-3. HP-85 IEEE-488 BASIC Statement

Statement	Action	Bus Command Sequence
ABORTIO 7	Send IFC.	IFC
CLEAR 7	Send DCL.	ATN•DCL
CLEAR 720	Send SDC to device 20.	ATN•UNL;MTA;LAG;SDC
ENTER 720;A\$	Device 20 addressed to talk. Data placed in A\$.	ATN•UNL;MLA;TAG;ATN;data
LOCAL 720	Send GTL to device 20.	ATN•UNL;MTA;LAG;GTL
OUTPUT 720;A\$	Device 20 addressed to listen. Transmit A\$.	ATN•MTA;UNL;LAG;ATN;data
REMOTE 7	Set REN true.	REN
REMOTE 720	Send REN true. Address device 20 to listen.	REN;ATN•UNL;MTA;LAG
RESET 7	Send IFC, cancel REN.	IFC;REN;REN
SROLL(720)	Address device 20 to talk. Conduct serial poll.	ATN•UNL;MLA;TAG;SPE;ATN; status byte;ATN•SPD;UNT
TRIGGER 7	Send GET	ATN•GET
TRIGGER 720	Address device 20 to listen. Send GET.	ATN•UNL;MTA;LAG;GET

AH (Acceptor Handshake Function)—The ability for the Model 1973 to guarantee proper reception of message/data on the data bus is provided by the AH function.

T (Talker Function)—The ability for the Model 1973 to send device-dependent data over the bus (to other devices) is provided by the T function. Model 1973 talker capabilities exist after the instrument has been addressed to talk.

L (Listener Function)—The ability for the Model 1973 to receive device-dependent data over the bus (from other devices) is provided by the L function. Listener function capabilities of the Model 1973 exist only after the instrument has been addressed to listen.

SR (Service Request Function)—The ability for the Model 1973 to request service from the controller is provided by the SR function.

RL (Remote Local Function)—The ability for the Model 1973 to be placed in the remote or local modes is provided by the RL function.

PP (Parallel Poll Function)—The Model 1973 does not have parallel polling capabilities.

DC (Device Clear Function)—The ability for the Model 1973 to be cleared (initialized) is provided by the DC function.

DT (Device Trigger Function)—The ability for the Model 1973 to have its basic operation started is provided by the DT function.

C (Controller Function)—The Model 1973 does not have controller capabilities.

TE (Extended Talker Capabilities)—The Model 1973 does not have extended talker capabilities.

LE (Extended Listener Capabilities)—The Model 1973 does not have extended listener capabilities.

3.3.4 Interface Commands

Interface commands controlling Model 197/1973 operation are listed in Table 3-5. Not included in the table are device-dependent commands, which are covered in detail in Section 4.

Table 3-4. Interface Function Codes

Code	Interface Function
SH1	Source Handshake Capability
AH1	Acceptor Handshake Capability
T5	Talker (Basic Talker, Serial Poll, Talk Only Mode, Unaddressed To Talk On LAG)
L4	Listener (Basic Listener, Unaddressed To Listen On TAG)
SR1	Service Request Capability
RL0	No Capability
PP0	No Parallel Poll Capability
DC1	Device Clear Capability
DT1	Device Trigger Capability
C0	No Controller Capability
E1	Open Collector Bus Driver
TE0	No Extended Talker Capabilities
LE0	No Extended Listener Capabilities

Table 3-5. IEEE Command Groups

HANDSHAKE COMMAND GROUP
DAV = DATA ACCEPTED
RFD = READY FOR DATA
DAV = DATA VALID
UNIVERSAL COMMAND GROUP
ATN = ATTENTION
DCL = DEVICE CLEAR
IFC = INTERFACE CLEAR
REN = REMOTE ENABLE
SPD = SERIAL POLL DISABLE
SPE = SERIAL POLL ENABLE
ADDRESS COMMAND GROUP
LISTEN: LAG = LISTEN ADDRESS GROUP
MLA = MY LISTEN ADDRESS
UNL = UNLISTEN
TALK: TAG = TALK ADDRESS GROUP
MTA = MY TALK ADDRESS
UNT = UNTALK
OTA = OTHER TALK ADDRESS
ADDRESSED COMMAND GROUP
ACG = ADDRESSED COMMAND GROUP
GET = GROUP EXECUTE TRIGGER
GTL = GO TO LOCAL
SDC = SELECTIVE DEVICE CLEAR
STATUS COMMAND GROUP
RQS = REQUEST SERVICE
SRQ = SERIAL POLL REQUEST
STB = STATUS BYTE
E0I = END

SECTION 4 OPERATION

4.1 INTRODUCTION

The Model 1973 is an IEEE interface for the Model 197 Autoranging Microvolt DMM. Since all IEEE operation is done through commands given over the bus, IEEE operation precludes the use of operating controls in the usual sense. Instead, all operating functions are controlled by programming.

This section describes important programming functions in detail. Included are: general bus commands, device-dependent commands, status word and status byte, and other important information. The information presented in this manual assumes that the operator is familiar with all normal aspects of Model 197 operation. For information on front panel operation, refer to the Model 197 instruction manual.

NOTE

Programming examples in this section assume that the Model 1973 primary address is set to 20. Those examples with addressed commands will not function unless the primary address of the instrument is set to that value. Refer to Section 3 for information on setting the primary address.

4.2 GENERAL BUS COMMANDS

General bus commands are those commands which have the same general meaning regardless of instrument configuration. These commands are grouped into two categories:

Addressed Commands—These commands require that the primary address of the instrument agrees with the primary address in the controller's language.

Unaddressed Commands—No primary address is required for these commands. All devices equipped to implement these commands will do so simultaneously when the command is sent.

General bus commands are summarized in Table 4-1, which also lists the HP-85 BASIC statement that sends each command. Each addressed command statement assumes a primary address of 20 (10100).

Table 4-1. General Bus Commands

Command	Addressing Required ?	HP-85 BASIC Statement
REN	Yes	REMOTE 720
IFC	No	ABORTIO 7
GTL	Yes	LOCAL 720
DCL	No	CLEAR 7
SDC	Yes	CLEAR 720
GET*	Yes	TRIGGER 720
GET*	No	TRIGGER 7

*GET may be sent with or without addressing.

4.2.1 REN (Remote Enable)

The remote enable command is sent to the Model 1973 by the controller to set the instrument up for remote operation. Generally, this should be done before attempting to program the instrument over the bus. The Model 197/1973 indicates that it is in the remote mode by turning on the front panel REMOTE indicator.

To place the Model 197/1973 in the remote mode, the controller must perform the following steps:

1. Set the REN line true.
2. Address the Model 197/1973 to listen.

NOTE

Setting REN true without addressing will not cause the REMOTE indicator to turn on; however, once the REN is true, the REMOTE indicator turns on the next time an addressed command is received.

Programming Example—This sequence is automatically sent by the HP-85 when the following is typed into the keyboard.

```
REMOTE 720 (END LINE)
```

After the END LINE key is pressed, the Model 197 REMOTE annunciator (RMT) should turn on. If not, check to see that the instrument is set for the proper primary address. Also check to see that all the bus connections are tight.

4.2.2 IFC (Interface Clear)

The IFC command is sent by the controller to set the Model 197/1973 to that talk and listen idle states.

To send the IFC command, the controller need only set the IFC line true.

Programming Example—Before demonstrating the IFC command, turn on the front panel remote (RMT) annunciator by entering the following statement into the HP-85 computer:

```
REMOTE 720 (END LINE)
```

The front panel remote (RMT) annunciator should now be on. The IFC command can now be sent by typing in the following statement:

```
ABORTIO 720 (END LINE )
```

After the END LINE key is pressed, the Model 197/1973 is in the talk idle state. Note that the remote mode is not cancelled.

4.2.3 GTL (Go To Local)

The GTL command is used to take the instrument out of the remote mode. To send the GTL command, the controller must perform the following sequence:

1. Set ATN true.
2. Address the Model 197/1973 to listen.
3. Place the GTL command on the bus.

Programming Example—If the instrument is not in the remote mode, enter the following statements into the HP-85 computer:

```
REMOTE 720 (END LINE)
```

Check to see that the RMT annunciator is on. The GTL command sequence is automatically sent by the HP-85 with the following statement:

```
LOCAL 720 (END LINE)
```

Note that the remote (RMT) annunciator on the front panel turns off.

NOTE

Setting the REN line false with the LOCAL 7 statement will also take the instrument out of the remote mode.

4.2.4 DCL (Device Clear)

The DCL command may be used to clear the Model 197, setting it to a known state. Note that all devices on the bus equipped to respond to a DCL will do so simultaneously. When the Model 197/1973 receives a DCL command, it will return to the default conditions listed in Table 4-2.

To send a DCL command, the controller must perform the following steps:

1. Set ATN true.
2. Place the DCL command on the bus.

Programming Example—Using front panel controls, select ACV and the 20V range. Type in the following statement into the HP-85 computer:

```
REMOTE 720 (END LINE)  
CLEAR 7 (END LINE)
```

When the END LINE key is pressed after the CLEAR 7 statement, the instrument returns to the default conditions listed in Table 4-2.

4.2.5 SDC (Selective Device Clear)

The SDC command performs the same function as the DCL command except that only the addressed device responds. This command is useful for clearing only a selected instrument instead of all instruments at once. The Model 197 returns to the default conditions listed in Table 4-2 when responding to a DCL command.

To transmit the SDC command, the controller must perform the following steps:

1. Set ATN true.
2. Address the Model 1973 to listen.
3. Place the SDC command on the bus.

Programming Example—Using front panel controls select REL, dB modes and the 200V range. Enter the following statements into the HP-85 computer:

```
REMOTE 720 (END LINE)  
CLEAR 705 (END LINE)
```

Note that the instrument did not respond to the SDC because the command was sent with a primary address of five. Now enter the following statement into the HP-85:

```
CLEAR 720 (END LINE)
```

Table 4-2. Default Values (Status Upon Power Up or After SDC or DCL)

Mode	Value	Status
Function	—	Reflects front panel selection.
Range	—	Reflects front panel selection.
Relative	Z0	
EOI	K0	Send EOI.
Trigger	T0	Continuous on Talk.
SRQ	M0	Disabled
Data Format	G0	Send prefix.
dB	D0	Off
Terminator	Y(CR LF)	CR LF
Data Logger	B0	Disabled

This time, the instrument returns to the default conditions listed in Table 4-2.

REMOTE 720 (END LINE)
S=SPOLL (720) (END LINE)
DISP S (END LINE)

4.2.6 Serial Polling (SPE, SPD)

The serial polling sequence is used to obtain the Model 197/1973 status byte. Usually, the serial polling sequence is used to determine which of several devices has requested service over the SRQ line. However, the serial polling sequence may be used at any time to obtain the status byte from the Model 197/1973. For more information on status byte format, refer to paragraph 4.3.8.

The serial polling sequence is conducted as follows:

1. The controller sets the ATN line true.
2. The SPE (Serial Poll Enable) command is placed on the bus by the controller.
3. The Model 197/1973 is addressed to talk.
4. The controller sets ATN false.
5. The instrument then places its status byte on the bus to be read by the controller.
6. The controller sets the ATN line true and places the SPD (Serial Poll Disable) on the bus to end the serial polling sequence.

Steps 3 through 5 may be repeated for other instruments on the bus by using the correct talk address for each instrument. ATN must be true when the talk address is transmitted and false when the status byte is read.

Programming Example—The HP-85 SPOLL statement automatically performs the serial polling sequence. To demonstrate serial polling, momentarily power down the instrument and power it up again. Enter the following statement into the HP-85 computer:

When the END LINE key is pressed after the S=SPOLL statement, the computer performs the serial polling sequence. When the END LINE key is pressed after DISP S statement, the status byte value (0) is displayed on the CRT. The status byte has a value of 0 with this example because no bits in the byte are set. Paragraph 4.3.8 covers the status byte format in detail.

4.3 DEVICE-DEPENDENT COMMAND PROGRAMMING

IEEE device-dependent commands are sent to the Model 197/1973 to control its various operating modes. Each command is made up of an ASCII alpha character followed by one or more numbers designating specific parameters. For example, dB is programmed by sending an ASCII "D" followed by a zero or one for turning it off or on. The IEEE bus treats device-dependent commands as data in that ATN is high when the commands are transmitted.

A number of commands may be grouped together in one string. A command string is terminated by an ASCII "X" character which tells the instrument to execute the command string.

If an illegal command or command parameter is present within a command string the instrument will:

1. Ignore the entire command string.
2. Set appropriate error bits in the status byte.
3. Generate an SRQ if programmed to do so.

These programming aspects are covered in paragraph 4.3.8. HP-85 examples are included throughout this section to clarify programming.

NOTE

Before a programming example, it is recommended that the instrument be set to its default values by sending an SDC over the bus. See paragraph 4.2.5 for information on using the SDC command.

If the HP-85 should become "hung up" at any point, operation may be restored by holding down the SHIFT key and then pressing RESET on the keyboard.

In order to send a device-dependent command, the controller must perform the following sequence:

1. Set ATN true.
2. Address the Model 197/1973 to listen.
3. Set ATN false.
4. Send the command string over the bus one byte at a time.

Programming Example—Device-dependent commands are sent by the HP-85 using the following statement:

```
OUTPUT 720;A$ (END LINE)
```

A\$ in this case contains the ASCII characters that form the command string.

NOTE

REN must be true when attempting to program the Model 197. If REN is false, the RMT annunciator will be off.

Commands that affect the Model 197 are listed in Table 4-3. All the commands listed in Table 4-3 are covered in detail in the following paragraphs.

NOTE

The programming examples that follow assume that the Model 197/1973 primary address is at its factory setting of 20 (10100).

4.3.1 Execute (X)

The execute command is implemented by sending an ASCII "X" over the bus. Its purpose is to tell the Model 197/1973 to

execute the other device-dependent commands. Generally, the "X" character is the last byte in the command string. Also, the execute character controls instrument operation in the T4 and T5 trigger.

NOTE

Command strings sent without an execute character will not be executed at that time. They will be stored in the command buffer. The next time an execute character is received, the stored commands are executed assuming all commands in the previous string were valid.

Programming Example—Enter the following statements into the HP-85 computer:

```
REMOTE 720 (END LINE)  
OUTPUT 720;"X" (END LINE)
```

The END LINE key is pressed after the execute statement, to show that the instrument received the command. No other changes occur with this example because no other commands were sent.

4.3.2 dB (D)

The dB function is the only function that can be programmed over the IEEE bus. The Model 197 must be manually set to DCV or ACV before dB can be enabled. The dB function is controlled by sending one of the following commands over the bus:

- D0 = dB off
- D1 = dB on

Upon power up, or after the instrument receives a DCL or SDC command, the D0 mode is enabled.

Programming Example—Using front panel controls place the Model 197 in the DCV function and enter the following statements into the HP-85 computer:

```
REMOTE 720 (END LINE)  
OUTPUT 720;"D1X" (END LINE)
```

When the END LINE is pressed after the D1X statement, the dB function is enabled as indicated by the dB annunciator.

4.3.3 Range (R)

The volts and ohms ranges are programmable over the bus.

The current ranges are not programmable. The Model 197 must be manually set to the volts (AC or DC) or ohms before the range commands can be effective. The range commands can be found in Table 4-4.

Upon power-up, or after receiving a DCL or SDC, the range of the Model 197 corresponds to the range pushbutton selected.

Programming Example—Cycle power on the Model 197 and manually select the 2VDC function and range. Enter the following statements into the HP-85:

REMOTE 720 (END LINE)
OUTPUT 720; "R5X" (END LINE)

When the END LINE is pressed the second time, the instrument switches to the R5 range (1000V).

NOTE

Other functions, except current, can be selected without affecting the programmed range. If the amps (A) function is selected, the Model 197 switches to the correct range that corresponds to the range pushbutton selected. Range control over the bus will be terminated.

Table 4-3. Device-Dependent Command Summary

Mode	Command	Description
dB	D0	dB off
	D1	dB on
Range	R0	Volts Auto Ohms Auto Amps —
	R1	200m 200 200 μ
	R2	2 2k 2m
	R3	20 20k 20m
	R4	200 200k 200m
	R5	1000 M Ω 2000m
	R6	— — 10A
Relative	Z0	REL off
	Z1	REL on
Trigger	T0	Continuous on talk.
	T1	One-shot on talk.
	T2	Continuous on GET.
	T3	One-shot on GET.
	T4	Continuous on X.
EOI	T5	One-shot on X.
	K0	EOI enabled.
Status Word	K1	EOI disabled.
	U0	Output status word.
SRQ Mode	Mnn	SRQ on error and/or data conditions.
Data Format	G0	Readings with prefix.
	G1	Readings without prefix.
Digital Calibration	V \pm n.nnnnnE \pm nn	n represents calibration value.
Store	L0	Store Calibration Constants.
Terminator	Y(ASCII)	ASCII character.
	Y(LF)	CR LF
	Y(CR)	LF CR
	Y(DEL)	None
Execute	X	Execute other device-dependent commands.
Data Logger	B0	Do Not send stored readings.

4.3.4 Relative (Z)

The REL mode serves as a means for a baseline suppression. When the correct REL command is sent over the bus, the instrument will enter the REL mode, as shown by the REL annunciator. All readings displayed or sent over the bus while REL is enabled are the difference between the stored baseline and the actual voltage level. For example, if a 100mV baseline is stored, 100mV will be subtracted from all subsequent readings as long as the REL mode is enabled. The value of the stored baseline can be a little as a few microvolts or as large as the selected range will permit. The REL mode is controlled by sending one of the following commands over the bus:

Z0 = REL Disabled
Z1 = REL Enabled

Upon power-up, or after DCL or SDC, Z0 is selected.

Programming Example—With the front panel REL button, disable the relative mode and enter the following statements into the HP-85 keyboard:

```
REMOTE 720 (END LINE)
OUTPUT 720;"Z1X" (END LINE)
```

After the END LINE key is pressed the second time, the REL annunciator will turn off.

NOTE

See the Model 197 Instruction Manual for detailed information on the use of the REL mode.

4.3.5 Triggering (T)

Triggering provides a stimulus to begin a reading conversion within the instrument. Triggering may be done in two basic ways: in a continuous mode, a single trigger command is used to start a continuous series of readings; in a one-shot trigger mode, a separate trigger stimulus is required to start each conversion. The Model 197 has six trigger commands as follows:

T0 Continuous On Talk
T1 One-Shot On Talk
T2 Continuous On GET
T3 One-Shot On GET
T4 Continuous On X
T5 One-Shot On X

Upon power-up or after a DCL or SDC command, the T0 mode is enabled. In the T0 and T1 modes, triggering is done by addressing the Model 197 to talk. In the T2 and T3

modes, a GET command provides the trigger stimulus. In the T4 and T5 modes, the execute (X) character triggers the instrument.

Programming Example—Place the instrument in the one-shot on talk mode with the following HP-85 statement sequence:

```
REMOTE 720 (END LINE)
OUTPUT 720;"T1X" (END LINE)
```

After the END LINE key is pressed the second time, the instrument will be in the one-shot on talk trigger mode. The instrument is waiting for a trigger.

Trigger the instrument with a talk command by entering the following statement into the HP-85:

```
ENTER 720;A$ (END LINE)
```

After pressing END LINE one reading will be processed. To continue taking readings in this mode, one talk command must be sent for each conversion.

Table 4-4. Range Commands

Range Command	Description	
	Volts	Ohms
R0	Auto	Auto
R1	200mV	200
R2	2 V	2k
R3	20 V	20k
R4	200 V	200k
R5	DCV—1000V	MΩ
	ACV—750V	

4.3.6 EOI (K)

The EOI line on the bus is usually set low by a device during the last byte of its data transfer sequence. In this way, the last byte is properly identified, allowing variable length data words to be transmitted. The Model 197 normally sends EOI during the last byte of its data string or status word. The EOI response of the instrument may be sent with one of the following commands:

K0 = Send EOI during last byte.
K1 = Send no EOI.

Upon power-up, the K0 mode is enabled.

Programming Example—Model 197 EOI response is suppressed with the following HP-85 statement sequence:

```
REMOTE 720 (END LINE)
OUTPUT 720;"K1X" (END LINE)
```

Note that the HP-85 does not normally rely on EOI to mark the last byte of data transfer. Some controllers, however, may require that EOI be present at the end of the transmitted string.

4.3.7 Status Word (U)

The status word commands allow access to information concerning present operating modes of the instrument. When the status word command is given, the Model 197 transmits status information instead of its normal data string the next time it is addressed to talk. The Model 197 status word command is:

U0 = Send instrument status on operating modes.

Figure 4-1 shows the general format for the U0 command. The letters in the U0 format corresponds to other device-dependent commands.

NOTES:

- Status word information is returned only once each time the command is sent. Once status is ready, the instrument sends its normal string the next time it is addressed to talk.
- The returned terminator character (Y) is derived by ANDing the 00001111 and ORing the result with 00110000. For example, the last byte in the normal (CR LF) terminator sequence is a LF or ASCII 10 (00001010). ANDing with 00001111 yields 00111010. ORing with 00110000 gives 00111010 which is printed out as an ASCII colon(:).
- The status word should not be confused with the status byte. The status word contains a number of bytes pertaining to the various operating modes of the instrument. The status byte is a single byte that is read with the SPE, SPD command sequence and contains information on SRQ status and error and data conditions.
- The returned SRQ mode (M) value is determined by adding up the value of the bit positions in the status byte that could cause an SRQ according to the previous programmed value of the SRQ mode. Refer to paragraph 4.3.8 for complete information on the SRQ mask and status byte.

Programming Example—Enter the following program into the HP-85. Be sure to include line numbers.

PROGRAM	COMMENTS
10 REMOTE 720	Set up instrument for remote operation.
20 OUTPUT 720;"U0X"	Send U0 status command.
30 ENTER 720;A\$	Enter status word into computer.
40 DISP"***FRZKTBMdMeY"	
50 DISP A\$	
60 END	

After entering the program, press the HP-85 RUN key. The U0 status word is then displayed on the CRT. Refer to Figure 4-1.

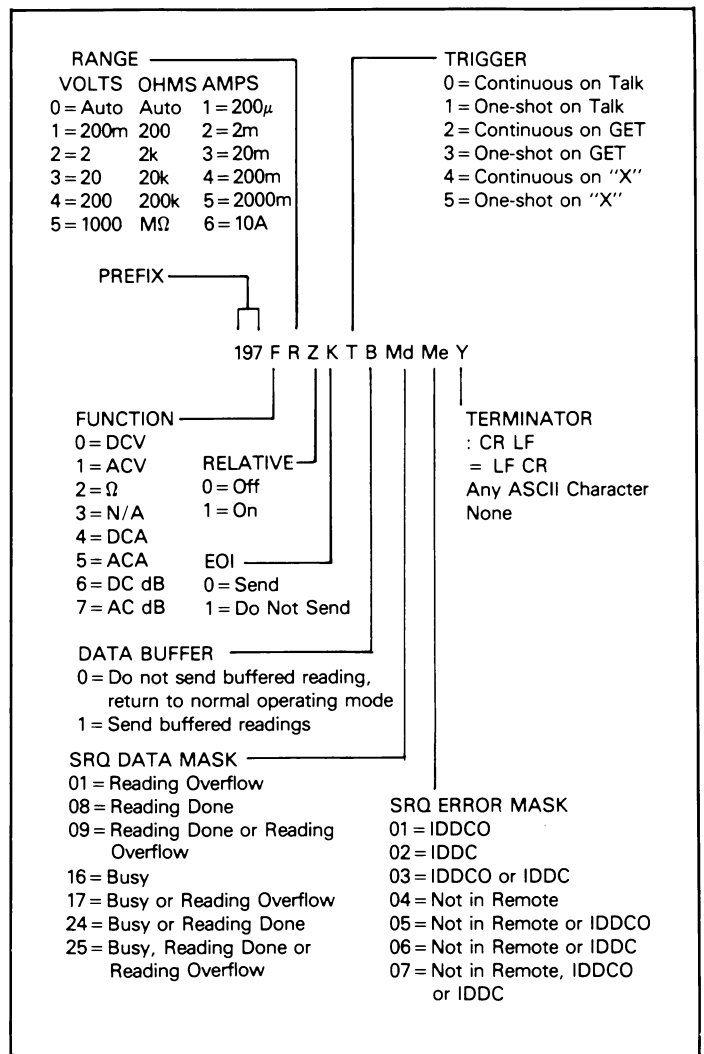

Figure 4-1. General Format for U0 Command

4.3.8 SRQ Mode (M) and Status Byte Format

The SRQ command code controls the number of conditions within the Model 197 which causes the instrument to request service from the controller with the SRQ command. Once the SRQ is generated, the Model 197 status byte can be checked to determine if it was the Model 197 that requested service. Other bits in the status cycle could also be set depending on certain data or error conditions.

The Model 197 can be programmed to generate an SRQ under one or more of the following conditions:

1. If a reading has been completed.
2. If an overflow condition occurs.
3. If a busy condition occurs.
4. If an Illegal Device-Dependent Command Option (IDDCO) is received.
5. If an Illegal Device-Dependent Command (IDDC) is sent.
6. If the instrument is not in remote when a command is sent.

Upon power up or after a DCL or SDC command, SRQ is disabled.

SRQ Mask—In order to facilitate SRQ programming, the Model 197 uses an internal mask to generate an SRQ. When a particular mask bit is set, the Model 197 sends an SRQ when those conditions occur. Bits within the mask can be controlled by sending the ASCII letter "M" followed by a decimal number to set the appropriate bits. Table 4-5 lists the commands to set the various mask bits, while Figure 4-2 shows the general mask format.

Programming Example—Cycle power on the Model 197 and program it for SRQ in IDDCO and output the status word.

PROGRAM	COMMENTS
10 REMOTE 720	Set up for remote operation.
20 OUTPUT 720;"M33X"	Program for SRQ on IDDCO.
30 OUTPUT 720;"U0X"	Send status command.
35 DISP"***FRZKTBMdMeY"	
40 ENTER 720; A\$	Enter commands into the computer.
50 DISP A\$	Display on CRT.
60 END	

After entering the program, press the HP-85 RUN key. The U0 status word will then be displayed. The Me bytes (refer to Figure 4-1) contain "01" indicating that the Model 197 is not programmed to SRQ on an IDDCO.

Status Byte Format—The status byte contains information relating to data and error conditions within the instrument. When a particular bit is set, certain conditions are present. Table 4-6 lists the meanings of the various bits and Figure 4-2 shows the general format of the status byte, which is obtained by using the SPE, SPD polling sequence described in paragraph 4.2.6.

If the status byte is read when no SRQ was generated by the Model 197 (bit 6 is clear), the current status of the instrument will be read. For example, if a reading was done, bit 3 would be set.

When a SRQ is generated by the Model 197, bit 6 of the status byte will be set. If a SRQ was caused by an error condition, bit 5 will also be set along with one of the error conditions (B0, B1 or B2). Only the error that caused the initial SRQ will be defined by the status byte.

If the SRQ was caused by a data condition, bit 5 will be clear and the appropriate data condition bits (B0, B3 and B4) will be set. If the busy condition caused the SRQ, then only the busy bit will be set.

After an SRQ, the status byte will remain unchanged until it is read. The various bits in the status byte are described below:

Reading Overflow—Set when an overrange input is applied to the instrument.

Reading Done—Set when the instrument has completed the present conversion and is ready to take another reading.

Busy—The instrument is still executing a prior command and is not ready to accept a new command.

IDDCO—An illegal command option such as R9 has been sent. This bit is cleared when the status byte is read.

IDDC—An illegal command will set this bit. For example, N1 is illegal since no such letter exists in the command set. The IDDC bit is cleared on a reading of the status byte.

Not in Remote—The Model 197 is in the local mode operation.

Table 4-5. SRQ Mask Commands

Command	Status Bits Enabled	Conditions to Generate SRQ
M0	—	Clear SRQ Data Mask
M1	B0	Reading Overflow
M8	B3	Reading Done
M9	B3, B0	Reading Done or Reading Overflow
M16	B4	Busy
M17	B4, B0	Busy or Reading Overflow
M24	B4, B3	Busy or Reading Done
M25	B4, B3, B0	Busy, Reading Done or Reading Overflow
M32	B5	Clear SRQ Error Mask
M33	B5, B0	IDDCO
M34	B5, B1	IDDC
M35	B5, B1, B0	IDDC or IDDCO
M36	B5, B2	Not in Remote
M37	B5, B2, B0	Not in Remote or IDDCO
M38	B5, B2, B1	Not in Remote or IDDC
M39	B5, B2, B1, B0	Not in Remote, IDDC or IDDCO

NOTES:

1. Once the Model 197 has generated an SRQ, its status byte must be read to clear the SRQ line. Otherwise the instrument continuously asserts SRQ.
2. The Model 197 may be programmed to generate an SRQ for more than one condition simultaneously.

Programming Example—Enter the following program into the HP-85 computer:

PROGRAM	COMMENTS
10 REMOTE 720	Set up for remote operation.
20 OUTPUT 720;"M33X"	Program for SRQ on IDDCO.
30 OUTPUT 720;"R9X"	Attempt to program illegal command option.
40 S=SPOLL(720)	Perform serial poll.
50 DISP"B7 B6 B5 B4 B3 B2 B1 B0"	
60 For I = 7 to 0 STEP -1	Loop eight times.
70 DISP BIT(S,I)	
80 NEXT I	
90 DISP	
100 DISP" v v v"	
110 DISP" SRQ ERROR IDDCO"	
120 DISP	
130 END	

NOTE

To align the display properly, type in the program exactly as shown. In line 100 the space between the first quotation marks and the first pointer is four spaces. Then to the next pointer is two spaces, and 14 spaces to the last pointer in the line. In line 110 the space between the first quotation marks and SRQ is two spaces. Then to ERROR is 2 spaces and then 10 spaces to IDDCO.

To run the program press the HP-85 RUN key. The computer conducts a serial poll and displays the status bits in order on the CRT. The SRQ (B6), error (B0) and IDDCO are set because line 30 of the program attempted to program the instrument with an illegal command option (R9).

After the program has been entered, press the HP-85 RUN key. Note the CRT, it will be as follows:

```

B7 B6 B5 B4 B3 B2 B1 B0
  0  1  1  0  0  0  1  0
      v  v          v
      SRQ ERROR    IDDCO
    
```

Bit 6 (B6) is set, meaning an SRQ condition exists. Bit 5 (B5) is also set, meaning there is an error condition. Bit 1 is set, meaning an Illegal Device-Dependent Command Option (IDDCO) condition exists.

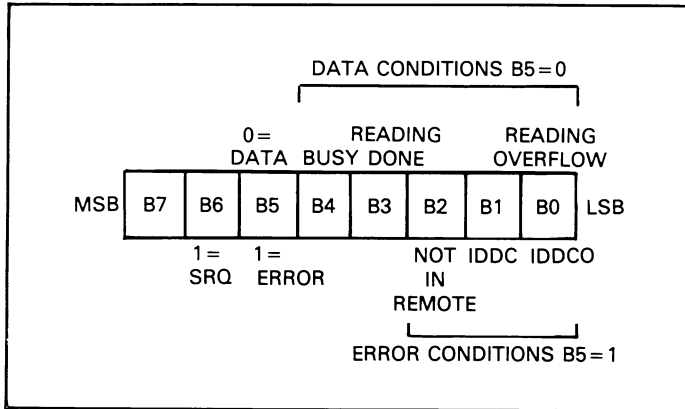

Figure 4-2. Status Byte Format

Table 4-6. Status Byte and Mask Interpretation

Bit	Bit 5 = 0 (Data Conditions)	Bit 5 = 1 (Error Conditions)
0 (LSB)	Overflow	IDDCO
1	N/A	IDDC
2	N/A	No remote
3	Reading done	N/A
4	Busy	N/A
5	Data	Error
6	SRQ	SRQ
7	N/A	N/A

Programming Example—Cycle power on the Model 197 (turn it off then on) and program it to output a data string.

PROGRAM	COMMENTS
10 REMOTE 720	Set up for remote operation.
20 ENTER 720;A\$	Enter command into computer.
30 DISP A\$	Display data string on CRT.
40 END	

To run the program press the HP-85 RUN key.

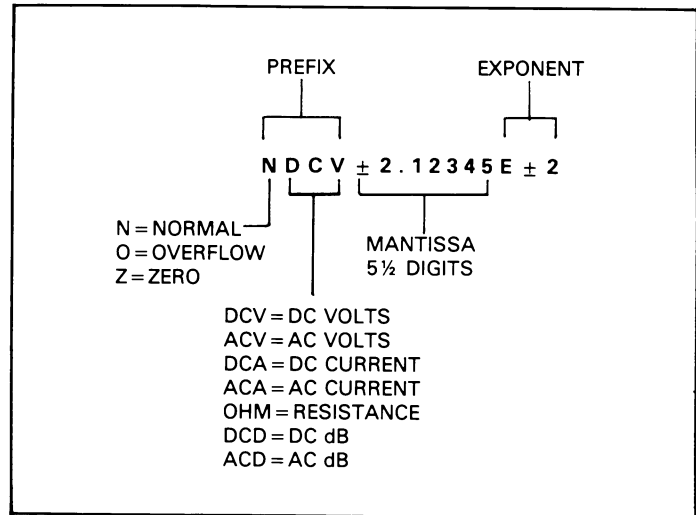

Figure 4-3. Data Format

4.3.9 Data Format

Model 197 is transmitted over the IEEE-488 bus as string of ASCII characters with the format shown in Figure 4-3. The first four characters indicate the function. The mantissa of the reading is made up of eight characters, including sign and decimal point, while the exponent requires three characters. To obtain the data string from the instrument, the controller must perform the following sequence:

1. Set ATN true (low).
2. Address the instrument to talk.
3. Set ATN false (high).
4. Input the data string one byte at a time.

NOTE

The data string can be transmitted without the prefix 197. Refer to paragraph 4.3.10 for more information. Also, the data string can be transmitted with the data pointer. Refer to paragraph 4.3.12 for more information.

4.3.10 Prefix (G)

With the use of the G command, the prefix for the status word or data string can be either transmitted or deleted. The commands are as follows:

- G0 = Include Prefix
- G1 = Suppress Prefix

Upon power up or after a DCL or SDC command, the G0 mode is enabled.

Programming Example—Program the Model 197 to output a data string without the prefix.

PROGRAM	COMMENTS
10 REMOTE 720	Set up for remote operation.
20 OUTPUT 720;"G1X"	Suppress prefix.
30 ENTER 720;A\$	Enter command into the computer.
40 DISP A\$	Display data string on CRT.
50 END	

To run the program press the HP-85 RUN key. The data string appears on the CRT without the prefix (NDCV). Refer to Figure 4-3. Figure 4-3 shows the data string format with the prefix.

4.3.11 Programmable Terminator (Y)

The Model 197 uses special terminator characters to mark the end of its data string or status word. To allow a wide variety of controllers to be used, the terminator can be changed by sending the appropriate command over the bus. The default value is the commonly used carriage return, line feed (CR LF) sequence. The terminator sequence assumes this default value upon power up or after the instrument receives a DCL or SDC.

The terminator may be programmed by sending the ASCII character Y followed by the desired terminator character. Any ASCII character except the following may be used:

1. Any capital letter.
2. Any number.
3. Blank
4. + - / , . or e

Special command characters will program the instrument for special terminator sequence as follows:

1. Y(LF) = CR LF (Two terminators)
2. Y(CR) = LF CR (Two terminators)
3. Y(DEL) = No terminator

NOTE

Most controllers use the CR or LF character to terminate their input sequence. Using a nonstandard terminator may cause the controller to hang up unless special programming is used.

Programming Example—The terminator can be eliminated by sending an ASCII DEL with the following HP-85 statements:

```
REMOTE 720 (END LINE)
OUTPUT 720;"Y";CHR$(127);"X" (END LINE)
```

When the END LINE key is pressed the second time, the terminator is suppressed; no terminator is sent by the instrument when data is requested. The absence of the normal terminator may be verified by entering the following statement into the HP-85 computer:

```
ENTER 720;A$ (END LINE)
```

At this point the HP-85 ceases to operate because it is waiting for the standard CR LF terminator sequence to terminate the ENTER statement. The computer may be reset by holding down the SHIFT key and pressing the RESET key on the keyboard. To return the instrument to the normal terminator sequence, enter the following statement into the HP-85 computer:

```
OUTPUT 720;"Y";CHR$(10);"X"(END LINE)
```

4.3.12 Data Logger Buffer (B)

Readings that have been stored in the Data Logger Buffer may be retrieved and sent over the IEEE-488 bus. The data in the data logger buffer is not discarded when it is retrieved. The data remains in the buffer until changed. The buffer is controlled by the B command as follows:

- B0 = Do not send stored readings and return the Model 197 to the normal operating mode.
- B1 = Send stored readings.

The readings are sent in the following format:

```
001, NDCV ± 1.23456E-3
Data Pointer Data Format (refer to Figure 4-3)
```

*Where Data Pointer data means:

- 101 = Maximum reading stored (n = HI in the Data Logger)
- 102 = Minimum reading stored (n = LO in the Data Logger)
- 001 = First reading stored (n = 01)
- ...
- ...
- ...
- 100 = 100th reading stored (n = 100)
- 000 = Not a buffered (stored) reading. Refer to note 2.

*This is the actual order in which the readings are sent.

NOTES:

1. A maximum of 102 readings (including Min/Max) can be stored by the Model 197.
2. After the last logged reading is sent, displayed readings are sent until the B0 command is given. These readings represent the signal level applied to the Model 197 input.
3. The display does not reflect logged data while being recalled over the bus.

Programming Example—Fill the buffer (Data Logger) with readings.

1. Press the STO/CLR button and hold it in until the desired store rate is displayed.
2. Release the STO/CLR button to select the store rate and start the data logger.
3. When the buffer is full, press the STO/CLR button to stop the data logger. The buffer is full when the RCL annunciator is blinking on the display.

Enter the following program into the HP-85 computer:

PROGRAM	COMMENTS
10 REMOTE 720	Set up for remote operation.
20 OUTPUT 720;"B1X"	Send stored readings.
30 FOR I=1 TO 103	Loop 103 times.
STEP 1	
40 ENTER 720;A\$	Obtain data string.
50 DISP A\$	Display the data.
60 NEXT I	
70 END	

After entering the program, press the HP-85 RUN key to start the program. After the RUN key is pressed the readings that were stored are displayed on the HP-85 CRT.

4.3.13 Digital Calibration (V) and Storage (L)

The Model 197 Autoranging Microvolt DMM has been improved to make calibration of the instrument more convenient for the user. Later versions of the Model 197 (with Revision B or C software) can now be calibrated without having to open up the unit.

To determine what software revision level your instrument has, hold in the dB button and turn on the Model 197. First, all LCD digits and annunciators turn on, then the software revision level will be displayed (for example, A1). The instrument will then run a display test and

go into troubleshooting diagnostics. Cycle power to return unit to normal operation.

Revision A Software

Calibration constant storage over the IEEE-488 bus can only be accomplished with the calibration jumper in the enabled position. See the Model 197 Instruction Manual, paragraph 5.6.3, for more information.

Use the V command to place the instrument in calibration and transmit a calibration value. Commands with values up to the range selected on the front panel or below will be accepted. The display of the Model 197 will indicate that the instrument has entered calibration by the appearance of the "C" annunciator.

If commands with values higher than the front panel range are selected, then they and all other commands in the string will be ignored and the instrument will not enter calibration.

The following calibration command transmits the calibration value to the instrument:

$$V + n.nnnnnE + nn$$

where:

- +n.nnnnn represents the mantissa (4-1/2 digits)
- E+nn represents the exponent

Through the use of the L0 command, the calibration values entered can be permanently stored. When the command is sent, the message "Stor" is displayed briefly, indicating that permanent storage has occurred. If instead the message "out" is displayed, then calibration storage was not enabled and the calibration constants will only be valid until the Model 197 is turned off.

NOTES:

1. Only as many significant digits as necessary need to be entered. For example, for calibration of the 20V range with a 19.0000V input value, the following command would be used:

$$V19X$$

2. The correct calibration signal must be applied to the instrument before the calibration command is sent.

Programming Example—Since the following example is for demonstration purposes only, the calibration constants will not be permanently stored.

CAUTION

Move the calibration jumper to the disabled position to ensure that permanent storage of the calibration constants cannot occur. Failure to do so could seriously affect instrument accuracy.

With permanent calibration storage disabled, select the 2VDC range. Connect a precise 1.90000VDC calibration voltage to the input terminals and enter the following statements into the HP-85:

```
REMOTE 720
OUTPUT 720; "V1.9X"
OUTPUT 720; "LOX"
```

When the second line is entered, the "C" annunciator will turn on to indicate that the instrument is in calibration. The display will show the calibration value entered in the V command, indicating the unit is calibrated to the input signal.

When the third line is selected, the unit displays the message "out" and the "C" annunciator blinks, indicating that the calibration constants were not permanently stored. The calibration constants will be lost when the instrument is turned off. (If storage had been selected, the constants would be stored and the message "Stor" would have been displayed).

Revision B Software

Storage of calibration constants in NVRAM can only occur if instrument calibration is first enabled. If the instrument is not placed in enable, subsequent calibration will be lost when the instrument is turned off. Perform the following steps to place the Model 197 in calibration storage enable:

1. If the Model 197 is presently on, turn it off using the ON/OFF power switch.
2. While holding in the STO/CLR button, turn on the instrument using the ON/OFF power switch.
3. When the message "CAL" is displayed, release the STO/CLR button. The instrument will return to its normal display and storage of calibration constants is now enabled.

Use the V command to place the instrument in calibration and transmit a calibration value. Commands with values up to the range selected on the front panel or below will be accepted. The display of the Model 197 will indicate that the instrument has entered calibration by the appearance of the "C" annunciator.

If commands with values higher than the front panel range are selected, then they and all other commands in the string will be ignored and the instrument will not enter calibration.

The following calibration command transmits the calibration value to the instrument:

$$V + n.nnnnnE + nn$$

where:

+n.nnnnn represents the mantissa (5-1/2 digits)
E + nn represents the exponent

Through the use of the L0 command the calibration values entered can be permanently stored. When the command is sent, the message "Stor" is displayed briefly indicating that permanent storage has occurred. If instead the message "out" is displayed, then calibration storage was not entered and the calibration constants will only be valid until the Model 197 is turned off.

NOTES:

1. Only as many significant digits as necessary need to be entered. For example, for calibration of the 20V range with a 19.0000V input value, the following command would be used:

$$V19X$$

2. The correct calibration signal must be applied to the instrument before the calibration command is sent.

Programming Example—Since the following example is for demonstration purposes only, the calibration constants will not be permanently stored.

CAUTION

Cycle power on the Model 197 to disable permanent calibration storage. Failure to do so could seriously affect instrument accuracy.

With permanent calibration storage disabled, select the 2VDC range. Connect a precise 1.90000VDC calibration voltage to the input terminals and enter the following statements into the HP-85:

```
REMOTE 720
OUTPUT 720; "V1.9X"
OUTPUT 720; "LOX"
```

When the second line is entered, the "C" annunciator will turn on to indicate that the instrument is in calibration.

The display will show the calibration value entered in the V command, indicating the unit is calibrated to the input signal.

When the third line is entered, the unit displays the message "out" and the "C" annunciator blinks, indicating that the calibration constants were not permanently stored. The calibration constants will be lost when the instrument is turned off. (If storage had been selected, the constants would be stored and the message "stor" would have been displayed).

Revision C Software

The Model 197 is shipped from the factory with its external calibration switch in DISABLED . In this position, calibration constants cannot be stored when entered from the front panel or over the IEEE-488 bus. The switch must be moved to ENABLED to allow calibration constants storage.

The calibration switch is located in the middle of the rear panel. Slide the switch to ENABLED.

Use the V command to place the instrument in calibration and transmit a calibration value. Commands with values up to the range selected on the front panel or below will be accepted. The display of the Model 197 will indicate that the instrument has entered calibration by the appearance of the "C" annunciator.

If commands with values higher than the front panel range are selected, then they and all other commands in the string will be ignored and the instrument will not enter calibration.

The following calibration command transmits the calibration value to the instrument:

$$V + n.nnnnnE + nn$$

where:

+n.nnnnn represents the mantissa (5-1/2 digits)
E + nn represents the exponent

Through the use of the L0 command the calibration value entered can be permanently stored. When the command is sent, the message "Stor" is displayed briefly, indicating that permanent storage has occurred. If instead the message "out" is displayed, then calibration storage was not enabled and the calibration constants will only be valid until the Model 197 is turned off.

NOTES:

1. Only as many significant digits as necessary need to be entered. For example, for calibration of the 20V range with a 19.0000V input value, the following command would be used:

V19X

2. The correct calibration signal must be applied to the instrument before the calibration command can be sent.
3. The calibration enable switch can be changed any time to enable calibration constant storage.

Programming Example—Since the following example is for demonstration purposes only, the calibration constants will not be permanently stored.

CAUTION

Place the calibration switch in DISABLED to ensure that permanent storage of the calibration constants cannot occur. Failure to do so could seriously affect instrument accuracy.

With permanent calibration storage disabled, select the 2VDC range. Connect a precise 1.90000VDC calibration voltage to the input terminals and enter the following statements into the HP-85:

REMOTE 720
OUTPUT; "V1.9X"
OUTPUT 720; "LOX"

When the second line is entered, the "C" annunciator will turn on to indicate that the instrument is in calibration. The display will show the calibration value entered in the V command, indicating the unit is calibrated to the input signal.

When the third line is entered, the unit displays the message "out" and the "C" annunciator blinks, indicating that the calibration constants were not permanently stored. The calibration constants will be lost when the instrument is turned off. (If storage had been selected, the constants would be stored and the message "Stor" would have been displayed).

4.4 TALK ONLY OPERATION

The talk only mode may be used to send data to a listen only device such as printer. When the Model 197 is in the talk only mode, it ignores commands given over the IEEE-488 bus. The talk only mode is enabled by placing the TO/ADDRESSABLE switch in the TO position (refer

to Figure 3-7) and cycling power to the instrument. The default talk rate is three readings per second (every reading). However, a different talk rate can be selected by performing the following procedure:

1. Press and hold the STO/CLR button. The following talk rates scroll on the display:
Rate/Meaning
r=0 Every reading
r=1 One reading per second
r=2 One reading per 10 seconds
r=3 One reading per one minute
r=4 One reading per 10 minutes
r=5 One reading per hour
r=6 One reading every time the STO/CLR button is pressed (when in the data logger mode).
2. Release the STO/CLR button when the desired talk rate is displayed. The STO annunciator turns on and the instrument talks at the selected rate. If r=6 is selected, press the STO/CLR button every time a reading is desired.

3. Turn off the data store by again pressing the STO/CLR button. The STO annunciator turns off.

NOTE

The instrument continues to talk at the selected rate until either a new rate is selected or power is cycled to the instrument.

When the Model 197 is used in the talk only mode, it may be interfaced with one or more listeners. Each of these devices and associated cabling should conform to IEEE-488-1978 standards.

The Model 197 transmits its normal data string in bit parallel byte serial fashion over the bus as requested by the listeners. The data format used is the same one used for addressable operation and is described in detail in paragraph 4.3.9. If the address switches are set to an even number the prefix is sent with the reading. An odd address number sends only the data.

SECTION 5

ANALOG OUTPUT (Model 1972 Only)

5.1 INTRODUCTION

The analog output is an exclusive feature of the Model 1972 IEEE-488 interface. It is useful for monitoring the input signal with an external device such as a chart recorder. The analog signal is reconstructed from digital data (supplied by the internal microprocessor) by a 13 bit D/A converter. Because of this condition the analog output accurately reflects the display until an overflow condition is reached. The analog output is optically isolated from the front panel LO terminal to avoid potential ground loop problems. There are two levels of gain for the analog output, the X1 gain and the X1000 gain. Refer to section 5.4.

On the X1 gain, 1V at the analog output corresponds to 100,000 counts. On the X1000 gain, 1V at the analog output corresponds to 100 counts.

The accuracy of the analog output is $\pm(0.25\%$ of displayed reading $+2\text{mV}$, where 2mV in X1000 = 0.2 displayed digits). Output of analog output is coincident with the display being updated.

5.2 USING THE ANALOG OUTPUT

The analog output is useful for monitoring the input signal with an external device such as a chart recorder. Using the analog output connected to chart recorder produces a hard-copy of the input signal over a period of time. Applications include monitoring reference or power supply drift, precision temperature measurement and control, or amplifier offset and gain time stability. By using the dB mode on the Model 197/1972, the instrument may be used to convert a linear signal to a logarithmic format.

1. Connect the measuring device to the two analog output terminals on the rear panel as shown in Figure 5-1.

CAUTION

The potential between the analog output LO terminal and earth ground must not exceed 30V peak. Make sure the external device does not exceed this voltage on its common or ground connections. Failure to observe this precaution may damage the

Model 197/1972. IEEE common is connected to analog output common.

WARNING

The potential between the input LO of the Model 197 and the analog output LO of the Model 1972 must not exceed 500V peak. Failure to observe this precaution may result in a dangerous potential being present on the analog output terminals and the IEEE connector. This situation could result in personal injury or death.

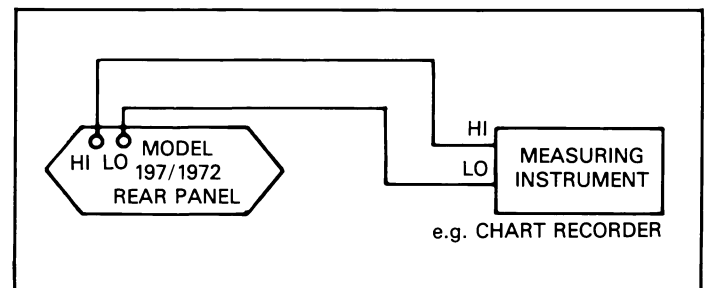

Figure 5-1. Analog Output Connections

2. Select the desired gain. The gain switch is located on the rear panel. A logic one (up position) is the X1000 gain. A logic zero (down position) is the X1 gain.

X1 gain—Set switch to logic 0.

X1000 gain—Set switch to logic 1.

In the X1 position, the most significant ± 4000 counts of the displayed reading can be covered. The span on this range (X1) is $\pm 4\text{V}$ in 1mV steps. The X1000 position changes the range to cover least significant ± 400 counts. The span on this range (X1000) is $\pm 4\text{V}$ in 1mV steps. In this manner, the entire $5\frac{1}{2}$ digits of the display may be represented.

3. If necessary, the analog output may be zeroed with REL function. To do so, press the REL button on the front panel. All subsequent readings are referenced to the previously displayed value. Refer to the Model 197 Instruction Manual for complete details concerning the REL function.

When using manual ranging, the Model 197 displays an "OL" message when the capability of a specific range is exceeded. When this message is displayed, the analog output value is +4V if the polarity of the input signal is positive and -4V if the input signal is negative.

An analog output range overflow can occur when the Model 197 analog range switch is in the X1 position. An example of the analog output voltage under these conditions is shown in Figure 5-2. The conditions shown are for the Model 197 in the 200mV range, but the output reacts similarly on the other voltage ranges if the proper scaling is applied. For each ten-fold increase in range, the scale of the horizontal axis must also be multiplied by a factor of ten.

The horizontal axis of Figure 5-2 has an input voltage range between -220mV and +220mV. These limits were chosen to show device connected to the analog output.

The analog output follows the input voltage linearly until the input voltage reaches 220mV (either positive or negative). The analog output then outputs the range overflow voltage of 4V (positive or negative) depending on the polarity of the input signal.

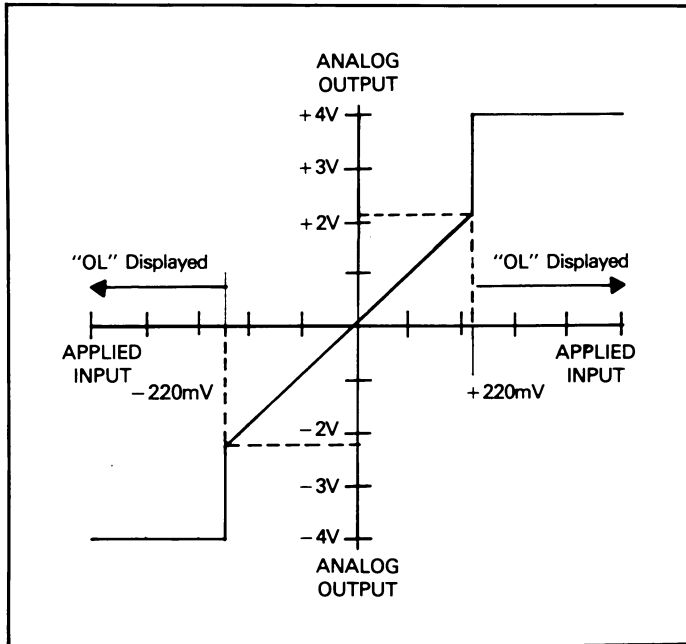

Figure 5-2. X1 Analog Output

A summary of analog output information is shown in Table 5-1, 5-2, 5-3 and 5-4. Each range of input values corresponds to the increment necessary to cause the analog output to go through its entire 0 to $\pm 4V$ range.

Table 5-1. Analog Output Parameters (V)

DCV Range	ACV Range	Input for 0-2.2V Analog Output X1	Input for 0-4V Analog Output X1000
200mV	200mV	0-220mV	0-400 μ V
2 V	2 V	0-2.2V	0-4mV
20 V	20 V	0-22V	0-40mV
200 V	200 V	0-220V	0-400mV
1000 V	750 V	0-1000V DC*	0-4.0V
		0-750V AC**	0-40V

*1V Full Range Maximum

**0.75V Full Range Maximum

Table 5-2. Analog Output Parameters (Ω)

Ohms Range	Input for 0-2.2V Analog Output X1	Input for 0-4V Analog Output X1000
200 Ω	0-220 Ω	0-400m Ω
2 k Ω	0-2.2k Ω	0-4.00 Ω
20 k Ω	0-22k Ω	0-40 Ω
200 k Ω	0-220k	0-400 Ω
2M Ω	0-2.2M Ω	0-4.0k Ω
20M Ω	0-22M Ω	0-40k Ω
200M Ω	0-220M Ω	0-400k Ω

Table 5-3. Analog Output Parameters (I)

DCA & ACA Range	Input for 0-2.2V Analog Output X1	Input for 0-4V Analog Output X1000
200 μ A	0-220 μ A	0-400nA
2mA	0-2.2mA	0-4.0 μ A
20mA	0-22mA	0-40 μ A
200mA	0-220mA	0-400 μ A
2000mA	0-2.2A	0-4.0mA
10 A	0-10A*	0-40.0mA

*1V Full Range Maximum

NOTE

In X1, the analog output may swing smoothly from 0 to $\pm 4V$ if REL is used properly.

Table 5-4. Analog Output Parameters (dB)

dB Range	Analog Output X1
-117dB thru + 64dB	-1.17V + .64V

NOTE: Use X1 gain in the dB mode.

5.3 OUTPUT RESISTANCE

The output resistance of the analog output is $1k\Omega$. This is true for all ranges regardless of the gain status. Thus, loading problems caused by external devices are minimized. In order to keep loading errors below 1%, the input resistance of any device connected to the analog output should be greater than $100k\Omega$.

5.4 X1000 MODE RESOLUTION AND ACCURACY

In the X1000 mode the analog output increases the resolution of the Model 197 beyond the $5\frac{1}{2}$ digits of the display. This provides an output step size of 2mV per each 0.2 counts of the displayed reading. For example, on the 200.000mV range, a 2mV step in the analog output voltage corresponds to a $0.2\mu V$ change in applied voltage to the Model 197. The extra resolution allows for a more continuous output when high resolution is required.

SECTION 6 THEORY OF OPERATION

6.1 INTRODUCTION

This section contains a circuit description of the Models 1973 and 1972 interfaces. The IEEE-488 interface option enables the Model 197 to be incorporated into a measurement system that utilizes programmed control through the IEEE-488 bus.

6.2 CIRCUIT DESCRIPTION

The entire IEEE-488 interface circuitry is located on a single board. The schematic number for the Model 1973 is 1973-106; and 1972-106 for the Model 1972. Figure 6-1 shows a simplified block diagram of the interface. The 12 bit DAC (U108) and the $\pm 4V$ Ref circuitry (U101A, B and C, Q101, Q102, VR101, U109 and associated circuitry) is not present on the Model 1973. The following descriptions cover the power supply, digital circuitry and analog output circuitry.

6.2.1 Power Supply

The positive supply (V+) provides power to the +5V regulator VR101, U109 and U110. The supply voltage to U109, U110 and VR101 must be a minimum of +7.0V and -6.2V to allow ample supply head room in order for the outputs to swing to their specified voltages.

The negative supply is generated using C112, CR102, CR103 and C108 configured as a voltage inverter. During the positive going cycle of the line, CR102 is forward biased allowing C112 to charge to the peak voltage of the AC IN. CR103 is reversed biased. On the negative going line cycle CR102 is reversed biased and CR103 is forward biased allowing the charge on C112 to be transferred onto C108. Thus charging C108 to $-V_p$ (negative peak voltage).

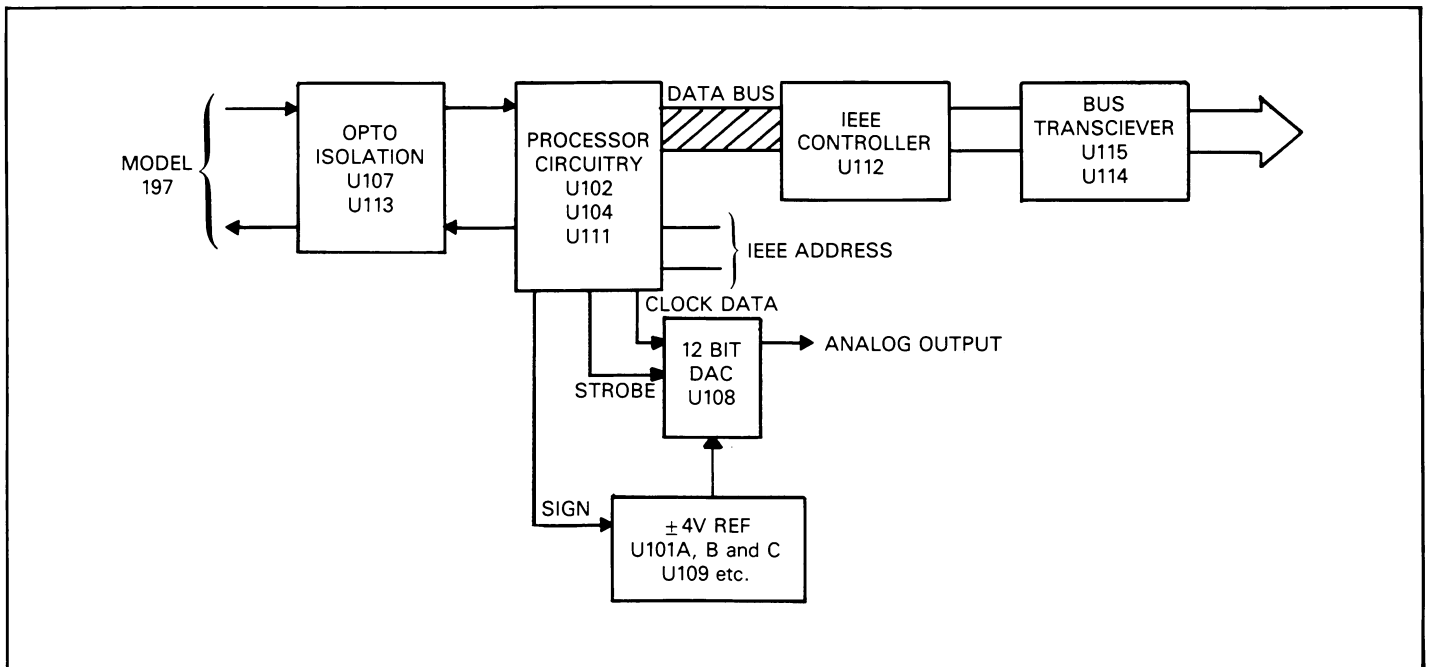

Figure 6-1. Simplified Block Diagram

6.2.2 Digital Circuitry

The digital circuitry consists of the microprocessor (U102), ROM (U104), decoder (U111), IEEE controller (U112) and bus transceivers (U114 and U115). Reset for the interface is accomplished by the internal reset feature of the microprocessor (MC6805E2) and its I/O line PB1. Upon power up the microprocessor executes an internal reset routine. This cycle lasts 1920 clock cycles (one cycle = 800kHz = 1.25 sec). After configuring itself, the processor sets PB1 low then high. This resets the IEEE controller (U112). Figure 6-2 shows the memory map for the interface.

The interface is capable of performing all IEEE-488 talker/listener protocols. The bidirectional data lines D0 through D7 permit the transfer of data between the microprocessor and the bus. The transceivers are used to drive the output and also buffer the data.

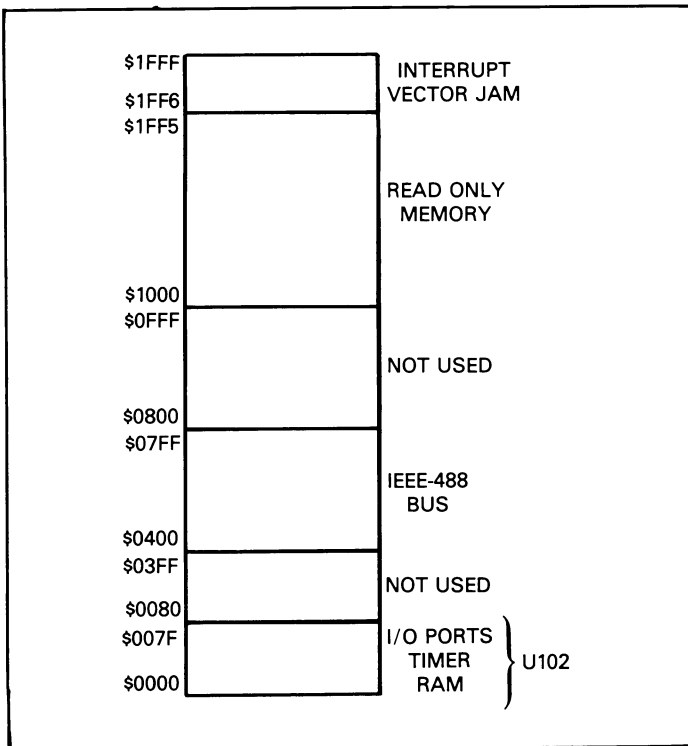

Figure 6-2. Memory Map

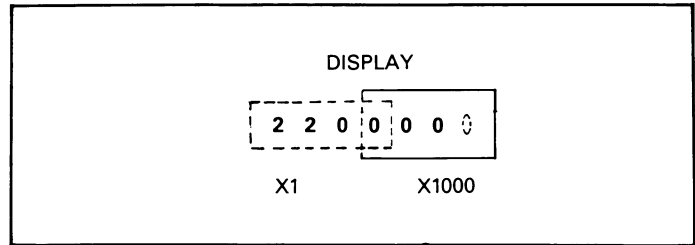

Figure 6-3. X1 and X1000 Gains

The primary address switches (SW101) select the primary address and permit 31 primary talker/listener address pairs. To address the Model 197, the controller must send the primary address of the Model 197. The factory set address is 20 (10100). The microprocessor reads the primary address from SW101 and then knows which talker/listener address to assign the IEEE controller and thus the Model 197.

NOTE

The primary address is updated only upon power up.

This section is accessed with the address switch enable (AS) signal. The AS signal is derived from the microprocessor and enables the decoder. Enabling the decoder places the address on the data bus (D0-D4 and D7).

6.2.3 Analog Output (Model 1972 only)

The analog output of the 1972 is derived from the displayed reading of the Model 197. This reading is sent over the opto interface to the Model 1972. The digital reading is then transformed to an analog output by a 13 bit DAC (Digital to analog converter) on the Model 1972.

The DAC is composed of a 12 bit serial input monolithic CMOS multiplying DAC and a 4V polarity switchable reference. The output of the DAC is given by:

$$V_{out} = -V_{ref} \frac{12 \text{ bit word}}{4096}$$

Data is sent to the serial input DAC over 3 control lines (Data, Clock and Strobe). The DATA is clocked into the DAC on the rising edge of the CLOCK. Once all 12 bits have been sent, pulling the strobe line low forces the output of the 12 bit DAC to a level corresponding to the new DAC input. The polarity of the 4V reference is controlled by the processor through U101, Q101 and Q102. For a positive reference voltage, the sign bit is low allowing +5V to be switched to the gate of Q101 grounding the anode of VR101. For a negative reference, the sign bit is high, gate voltage to Q102 is high and the cathode of VR101 is pulled to ground. U109 acts as a X3.2 buffer to boost the reference voltage from $\pm 1.25V$ to $\pm 4V$.

The analog output functions in one of two modes, X1 or X1000. In the X1 mode, the most significant 4000 counts of the display are used for determining the output. In the X1000 mode, the least significant 400 counts of the display and an internal sixth digit are used for determining the output. See Figure 6-3. The extra resolution allows a more continuous analog output when high resolution is required.

Opto-isolators U109 and U111 electrically isolate the Model 197 from the Model 1972/1973 interface. This isolation allows the Model 197 to maintain its 500V common mode floating specification. The specification is maintained even if the interface is referenced to the IEEE controller ground.

In normal operation, when used with the Model 197, the output of the DAC varies between $-2.2V$ to $+2.2V$. Below $-2.2V$ or above $+2.2V$ results in an analog output voltage of $-4V$ and $+4V$ respectively. This indicates an overload condition.

It is possible for the analog output to swing between $\pm 2.2V$ and $\pm 4V$ if the REL feature is used properly. Refer to the Model 197 Instruction Manual.

SECTION 7 MAINTENANCE

7.1 INTRODUCTION

This section contains information necessary to maintain the Model 1973 and the Model 1972 IEEE-488 interface. Installation procedures, troubleshooting information and instruction concerning care in handling static sensitive devices are included.

WARNING

All service information is intended for qualified electronic maintenance personnel only.

7.2 INSTALLATION

The Model 1973 and the Model 1972 are field installable. To install either interface (not both) into the Model 197 use the following procedure and refer to Figure 7-1.

WARNING

To prevent a shock hazard, turn off the Model 197, remove all test leads from the instrument and unplug the line cord.

1. Remove and retain the top cover. The top cover is secured by four screws that are accessible from the bottom of the instrument.
2. Install the rear standoff (ST-171-1) by positioning it over the hole on PC board as shown in Figure 7-1, and pressing firmly until it snaps securely into the board.
3. Install the cable clamp so that there will be no slack in the display cable under the IEEE board.
4. Position the interface board loosely on the rear standoff.

WARNING

Do not push down on J1008. The male connector pins will pass through J1008 and may cause personal injury.

5. Guide the terminals of P1008 into J1008 and firmly push down on that end of the board to mate the connectors.
6. Push down on the other side of the interface board until it snaps onto the rear standoff. Make sure the board is seated properly on the front standoffs.
7. Install the modified top cover.

WARNING

If the interface (Model 1972 or Model 1973) is removed, use the original top cover supplied with the Model 197 (if available). If the modified top cover is used, cover the holes normally occupied by the IEEE connector and switch. Failure to cover these holes could result in a shock hazard that could cause severe injury or death.

7.3 CALIBRATION (Model 1972 only)

Calibration of the Model 1972 should be performed every 12 months. If any of the calibration procedures in this section cannot be performed properly, refer to the troubleshooting information in this section. If the problem persists, contact your Keithley representative or the factory for further information.

7.3.1 Warm Up

The Model 197, with the Model 1972 or Model 1973 installed, requires one hour for warm up to achieve rated specifications. The top cover must be installed.

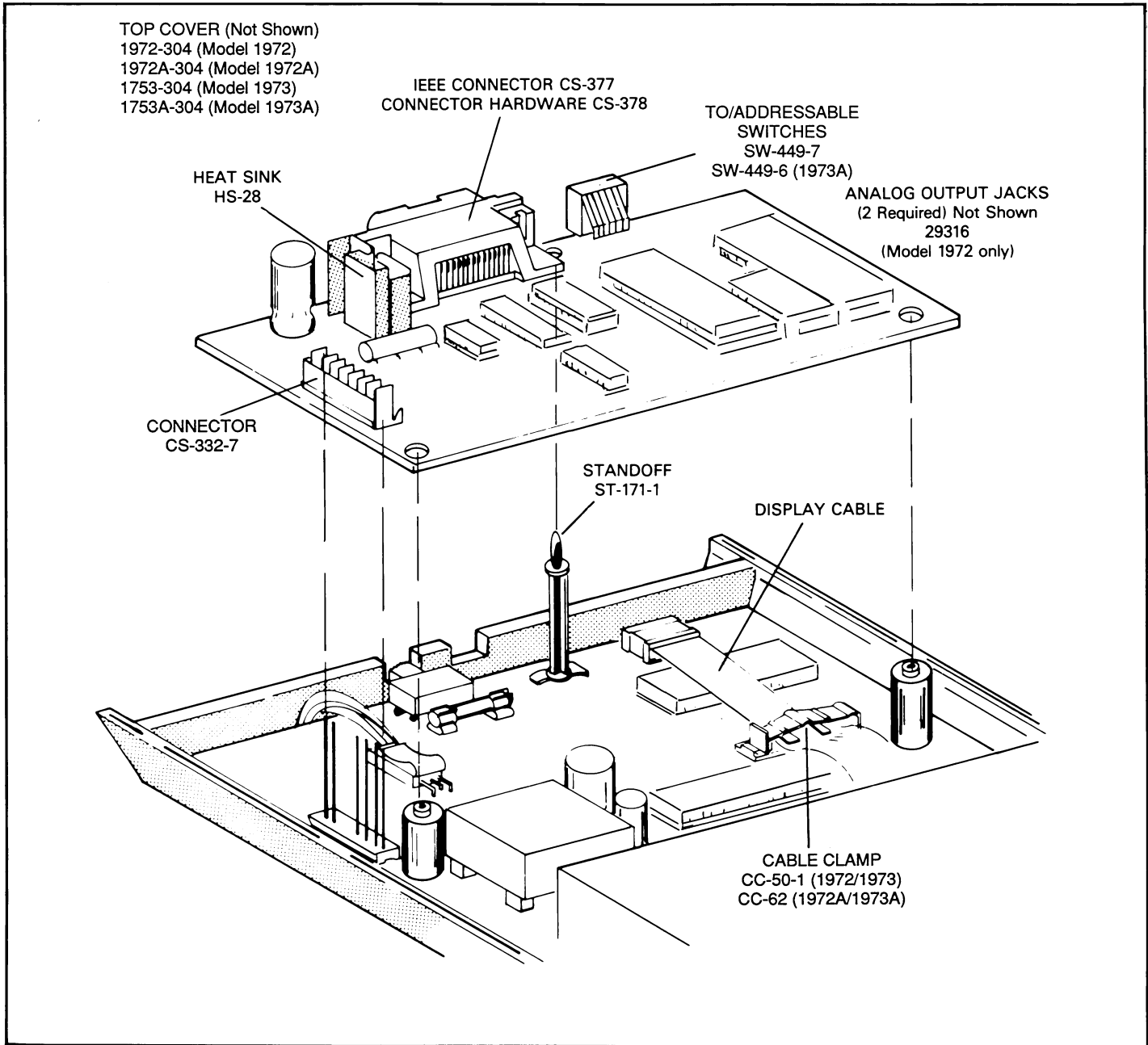

Figure 7-1. IEEE-488 Interface Installation

7.3.2 Recommended Calibration Equipment

Calibration of the Model 1972 may be done with the equipment listed below. Alternate equipment may be used but the specifications must be at least as accurate as the specifications as follows:

- DC Calibrator—0.01% on 10V range.
- DMM 4½ digit—0.03% -1 count on 2V range.

7.3.3 Environmental Conditions

Calibration should take place in laboratory conditions having an ambient temperature of 23°C ± 3°C and a relative humidity of less than 70%. If the instrument has been subjected to temperatures outside of this range or to higher humidity allow at least one additional hour for the instrument to stabilize before beginning calibration procedure.

7.3.4 Calibration

Perform the following steps to calibrate the Model 1972.

1. Turn on the instrument and allow one hour for warm up.
2. Select DCV and the 2V range. Set the Model 1972 for the X1 gain.
3. Apply +1.9000V to the Model 197 input.
4. Measure the analog output voltage with the 4½ digit DMM.
5. Adjust R112 until the analog output reads within ±0.0004V of the Model 197 displayed reading.
6. Model 1972 calibration is now complete.

7.4 SPECIAL HANDLING OF STATIC SENSITIVE DEVICES

MOS devices are designed to function at very high impedance levels. Normal static charge can destroy these devices. Table 7-1 lists all the static sensitive devices for the Model 1972 and the Model 1973. Steps 1 through 7 provide instruction on how to avoid damaging these devices.

1. Devices should be handled and transported in protective containers, antistatic tubes or conductive foam.
2. Use a properly grounded work bench and a grounding wrist strap.
3. Handle the devices only by the body. Do not touch the pins.
4. The PC boards must be grounded to the bench while inserting devices.
5. Use antistatic solder suckers.
6. Use grounded tip soldering.
7. After devices are soldered or inserted into sockets, they are protected and normal handling may resume.

Table 7-1. Static Sensitive Devices

Circuit Designation		Keithley Part No.	
Model 1972	Model 1973	Model 1972	Model 1973
U101	U101	IC-283	LSI-60
U102	U102	LSI-60	IC-341
U103	U103	IC-341	IC-106
U104	U104	1972-800-**	1973-800-**
U105, U106	U105	IC-106	IC-338
	U111		IC-106
U108		IC-419	
U111			

7.4 TROUBLESHOOTING

The troubleshooting information in this section is intended for use by qualified personnel who have a basic understanding of the analog and digital circuitry used in a IEEE-488 interface. Instructions have been written to assist in isolating the defective circuit. Isolating the defective component has been left to the technician. Refer to Table 7-2 for IEEE-488 interface board checks.

NOTE

For instruments that are still under warranty (less than 12 months since date of shipment), whose performance falls outside specification at any point, contact your Keithley representative or the factory before attempting troubleshooting or repair.

Table 7-2. Model 1972 Interface Checks

Step	Item/Component	Required Condition	Remarks
1*	J1008 Pin 1 referenced to Pin 2	+5V \pm 10% Referenced to digital common on motherboard.	+5V Digital Supply
2	VR104 OUT	+5V \pm 10%	+5V Digital Supply
3	VR104 IN	+8.5V \pm 10%	+V
4	CR103 Anode	-8.5V \pm 10%	-V
5	S101 (1-7)	In the "1" position the switch is pulled up to +5V \pm 10%	Primary Address
6	U104 Pin 18	1MHz square wave at 0V to +5V.	Clock to U104
7	U102 Pin 2	+5V Level (when not connected to bus)	IRQ Line
8	U112 Pin 19	+5V Level (when not connected to bus)	RESET Line
9	Program the Model 197 into the Remote Mode (primary address 20)		
10	U114 Pins 19 and 2	0V \pm 0.5V	REN Line (low true)
11	U114 Pins 18 and 3	+5V \pm 10%, pulsed low when an IFC command is sent.	IFC Line
12	U114 Pins 4 and 17	Handshaking sequence, refer to paragraph 2.3.2.	NRFD Line
13	U114 Pins 16 and 5	Handshaking sequence, refer to paragraph 2.3.2.	NDAC Line
14	U114 Pins 15 and 6	Handshaking sequence, refer to paragraph 2.3.2.	DAV Line
15	U114 Pins 14 and 7	+5V \pm 10%, pulsed low at the end of multibyte transfer sequence in the K0 mode.	EOI
16	U114 Pins 13 and 8	0V \pm 0.5V when processing multiline commands. Otherwise +5V \pm 10%. Refer to paragraph 2.3.2.	ATN Line
17	U114 Pins 12 and 9	0V \pm 0.5V when SRQ condition exists. Refer to paragraph 4.3.8.	SRQ Line
18	U102 Pin 4	0V to +5V pulses at \approx 800kHz rate.	DS (data strobe)
19	U102 Pin 6	0V to +5V pulses at \approx 800kHz rate.	AS (address strobe)
20	U105 pins 4, 6, 10, 12 and 15	0V to 5V data pulses.	
21	U106 Pins 2, 4, 6 and 10	0V to 5V data pulses.	
22	U102 Pin 34	+5V Pulses	Strobe Line (analog out)
23	U102 Pin 33	+5V Pulses	Data Line (analog out)
24	U102 Pin 36	+5V Pulses	Clock Line (analog out)
25	U102 Pin 35	+5V pulsed low when reset.	RESET Line
26	U109 pin 6	\pm 4V \pm 0.005%	-4V for positive input (e.g. 1V) +4V for negative input (e.g. -1V)
27	U109 pin 3	\pm 1.25V \pm 2.5%	-1.25V for positive input (e.g. 1V) +1.25V for negative input (e.g. -1V)

*Referenced to Motherboard digital common

NOTE

All steps are referenced to analog common.

Table 7-3. Model 1973 Interface Checks

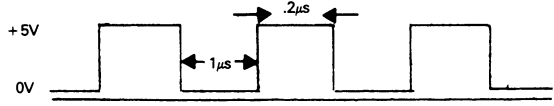
Step	Item/Component	Required Condition	Remarks
1*	J1008 Pin 1 reference to Pin 2	+5V \pm 10% Referenced to digital common on motherboard.	+5V Digital Supply
2	VR101 OUT	+5V \pm 10%	+5V Digital Supply
3	VR101 IN	+8.5V \pm 10%	+V
4	S101 (1-7)	In the "1" position the switch is pulled up to +5V \pm 10%	Primary Address
5	U104 Pin 18	1MHz square wave at 0V to +5V	Clock to U104
6	U101 Pin 19	+5V Level (when not connected to bus)	IRQ Line
7	U106 Pin 19	+5V Level (when not connected to bus)	RESET Line
8	Program the Model 197 into the Remote Mode (primary address 20)		
9	U108 Pins 19 and 20	0V \pm 0.5V	REN Line (low true)
10	U108 Pins 18 and 3	+5V \pm 10%, pulsed low when an IFC command is sent.	IFC Line
11	U108 Pins 4 and 17	Handshaking sequence, refer to paragraph 2.3.2.	NRFD Line
12	U108 Pins 16 and 5	Handshaking sequence refer to paragraph 2.3.2.	NDAC Line
13	U108 Pins 15 and 6	Handshaking sequence, refer to paragraph 2.3.2.	DAV Line
14	U108 Pins 14 and 7	+5V \pm 10%, pulsed low at the end of multibyte transfer sequence in the K0 mode.	EOI
15	U108 Pins 13 and 8	0V \pm 0.5V when processing multiline commands. Otherwise +5V \pm 10%. Refer to paragraph 2.3.2.	ATN Line
16	U108 Pins 12 and 9	0V \pm 0.5V when SRQ condition exists. Refer to paragraph 4.3.8.	SRQ Line
17	U101 Pin 4	0V to +5V pulses at \approx 800kHz rate.	DS (data strobe)
18	U101 Pin 6	0V to +5V pulses at \approx 800kHz rate.	AS (address strobe)
19	U103 Pins 4, 6, 10, 12 and 15	0V to 5V data pulses.	
20	U111 Pins 2, 4, 6 and 10	0V to 5V data pulses.	

*Refer to Motherboard digital common.

NOTE

All steps are referenced to analog common.

SECTION 8 REPLACEABLE PARTS

8.1 INTRODUCTION

This section contains replacement parts information, component location drawings and schematic diagrams for the Model 1972 and the Model 1973.

8.2 REPLACEABLE PARTS

Parts are listed alpha-numerically in order of the schematic designation. Table 8-1 contains parts list information for the Model 1973. Table 8-2 contains parts list information for the Model 1972.

8.3 ORDERING INFORMATION

To place an order, or to obtain information concerning replacement parts, contact your Keithley representative or the factory. See the inside front cover for addresses. When ordering include the following information:

1. Instrument Model Number
2. Instrument Serial Number

3. Part Description
4. Circuit Description (if applicable)
5. Keithley Part Number

If an additional instruction manual is required, order the manual package (Keithley part number 1973-901-00). The manual package includes an instruction manual and all pertinent addenda.

8.4 FACTORY SERVICE

If the instrument is to be returned to the factory for service, photocopy and complete the service form which follows this section and return it with the instrument.

8.5 SCHEMATIC DIAGRAMS AND COMPONENT LOCATION DRAWINGS

The component location drawings of the Model 1973 and the Model 1972 are shown in Figures 8-1 and 8-2 respectively. The schematic diagrams of the Model 1973 and the Model 1972 are shown in Figures 8-3 and 8-4 respectively.

Table 8-1. Model 1973 Parts List

Schematic Desig.	Description	Location		Keithely Part No.
		Sch	Pcb	
C101	Capacitor, 0.1 μ F, 50V, Ceramic	B1	C2	C-365-.1
C102	Capacitor, 22pF, 100V, Ceramic Disc	A3	D2	C-22-22p
C103	Capacitor, 22pF, 100V, Ceramic Disc	A3	D2	C-22-22p
C104	Capacitor, 0.1 μ F, 50V, Ceramic	D1	D2	C-365-.1
C105	Capacitor, 0.1 μ F, 50V, Ceramic Film	F3	D3	C-237-.1
C106	Capacitor, 2200 μ F, 16V, Aluminum Electrolytic	B5	F3	C-351-2200
C107	Capacitor, 0.1 μ F, 50V, Ceramic	C5	E3	C-365-.1
C108	Capacitor			C-314-4.7
CR101	Rectifier, Bridge	B5	F3	RF-52
J1008	7 pin Molex Connector	B5	F2	CS-332-7
J1011	IEEE-488 Connector	G3	D3	CS-377
K101	Relay, 5V	D5	E2	RL-83
R101	Thick Film Resistor Network	B1	D3	TF-99
R102	Resistor, 10M, 5%, 1/4W, Composition	B3	D2	R-76-10M
R103	Resistor, 10k, 5%, 1/4W, Composition	C5	E2	R-76-10k
R104	Resistor, 100k, 5%, 1/4W, Composition	C5	E2	R-76-100k
R105	Resistor, 330 Ω , 5%, 1/4W, Composition	C6	E2	R-76-330
R106	Resistor, 330 Ω , 5%, 1/4W, Composition	D5	F2	R-76-330
R107	Resistor, 10k, 5%, 1/4W, Composition	D5	F2	R-76-10k
R108	Resistor, 100k, 5%, 1/4W, Composition	D6	F2	R-76-100k
R109	Resistor, 10k, 5%, 1/4W, Composition			R-76-10k
SW101	Bank of 7 dip switches (Primary Address)	A2	D3	SW-449-6
U101	CMOS 8 Bit Microprocessor, 146805E2	B2	C2	LSI-60
U102	Triple 3-Input NAND Gate, MM74HC10	Sev	D2	IC-341
U103	Hex Inverter, 4049	B5	E2	IC-106
U104	4Kx8 UV Erasable PROM 2732	D2	D2	1973-800-**
U105	Octal D Latch, 74HC373	D3	D2	IC-338
U106	GPIB Adapter, 9914	F3	D2	LSI-49
U107	GPIB Transceiver, 75160	F2	E3	IC-298
U108	GPIB Transceiver, 75161	F3	D3	IC-299
U109	OPTO Coupler, TIL117	D5	E2	IC-362
U110	OPTO Coupler, TIL117	D6	F2	IC-362
U111	Hex Inverter, 4049	C5	F2	IC-106
VR101	+5V Regulator, 7805CP5	C5	E3	IC-93
	Heat Sink for VR101	-	F3	HS-28
Y101	Crystal, 4.0MHz	B3	D2	CR-10

**Order same software as presently installed. For example: If software level is A1 then order 1973-800-A1 for U104.

Table 8-2. Model 1972 Parts List

Schematic Desig.	Description	Location		Keithly Part No.
		Sch	Pcb	
C101	Capacitor, 4.7 μ F, 25V, Aluminum Electrolytic	B5	C1	C-314-4.7
C102	Capacitor, 22pF, 100V, Ceramic Disc	B3	D2	C-22-22p
C103	Capacitor, 22pF, 100V, Ceramic Disc	B3	D2	C-22-22p
C104	Capacitor, 0.1 μ F, 50V, Ceramic	E1	D2	C-365-.1
C105	Capacitor, 0.1 μ F, 50V, Ceramic	C1	C2	C-365-.1
C106	Capacitor, 100pF, 100V, Ceramic Disc	B4	C2	C-22-100p
C107	Capacitor, 100pF, 100V, Ceramic Disc	A3	C2	C-22-100p
C108	Capacitor, 250 μ F, 25V, Aluminum Electrolytic	C5	F2	C-314-220
C109	Capacitor, 0.1 μ F, 50V, Ceramic Film	G3	D3	C-237-.1
C110	Capacitor, 0.1 μ F, 50V, Ceramic	D5	E3	C-365-.1
C111	Capacitor, 2200 μ F, 16V, Aluminum Electrolytic	D5	E3	C-351-2200
C112	Capacitor, 250 μ F, 25V, Aluminum Electrolytic	C5	F3	C-314-220
C113	Capacitor, 1 μ F, 50V, Metalized Polyester	A2	C3	C-350-1
C114	Capacitor, 0.1 μ F, 50V, Ceramic	A3	C3	C-365-.1
C115	Capacitor, 4.7 μ F, 25V, Aluminum Electrolytic			C-314-4.7
CR101	Rectified, Bridge	C5	F3	RF-52
CR102	Rectified, Silicon, 1N4006	C5	F3	RF-38
CR103	Rectified, Silicon, 1N4006	C5	F3	RF-38
J1008	7 pin Molex Connector	C5	F2	CS-332-7
J1011	IEEE-488 Connector	H3	D3	CS-377
J1012	Jack	A3	C3	29316-A
J1013	Jack	A3	C3	29316-A
K101	Relay, 5V	E5	E2	RL-83
Q101	MOSFET, N-Channel Enhancement Mode	B5	C2	TG-177
Q102	MOSFET, N-Channel Enhancement Mode	A5	C2	TG-177
R101	Resistor, 10M, 5%, 1/4W, Composition	C3	D2	R-76-10M
R102	Resistor, 10k, 5%, 1/4W, Composition	D5	E2	R-76-10k
R103	Resistor, 30.1k, 1%, 1/8W, Metal Film	B5	C2	R-88-30.1k
R104	Resistor, 19.6k, 1%, 1/8W, Metal Film	B4	C2	R-88-19.6k
R105	Resistor, 29.4k, 0.1%, 1/8W, Fixed	A4	C2	R-176-29.4k
R106	Resistor, 10k, 1%, 1/8W, Metal Film	A4	C2	R-177-10k
R107	Resistor, 100k, 5%, 1/4W, Composition	D5	E2	R-76-100k
R108	Resistor, 330 Ω , 5%, 1/4W, Composition	D6	E2	R-76-330
R109	Resistor, 10k, 5%, 1/4W, Composition	E5	F2	R-76-10k
R110	Resistor, 100k, 5%, 1/4W, Composition	E5	F2	R-76-100k
R111	Resistor, 330 Ω , 5%, 1/4W, Composition	E5	F2	R-76-330
R112	Potentiometer, 5k	A4	C3	RP-89-5k
R113	Resistor, 1k, 10%, 1/2W, Composition	A3	C3	R-1-1k
R114	Thick Film Resistor Network	C1	D3	TF-99
R115	Resistor, 10k, 5%, 1/4W, Composition			R-76-10k
SW101	Bank of 7 dip switches (Primary Address)	B2	D3	SW-449-7
U101	Triple 2-Channel Analog Multiplexer, CD4053BC	Sev	C1	IC-283
U102	CMOS 8 Bit Microprocessor, 146805E2	C3	C2	LSI-60
U103	Triple 3-Input NAND Gate, MM74HC10	Sev	D2	IC-341
U104	4K \times 8 UV Erasable PROM, 2732	E2	D2	1972-800-**
U105	Hex Inverter, 4049	C5	E1	IC-106
U106	Hex Inverter, 4049	E5	F1	IC-106
U107	OPTO Coupler, TIL117	E5	E2	IC-362
U108	Serial Input 12-Bit DAC, 7543KN	B3	C2	IC-419
U109	Op Amp, 308A	B4	C2	IC-203
U110	Op Amp, 308A	A3	C2	IC-203
U111	Octal D Latch, 74HC373	E4	D2	IC-338

**Order same software as presently installed. For example: If software level is A1 then order 1972-800-A1 for U104.

Table 8-2. Model 1972 Parts List (Cont.)

Schematic Desig.	Description	Location		Keithley Part No.
		Sch	Pcb	
U112	GPIB Adapter, 9914	G3	D2	LSI-49
U113	OPTO Coupler, TIL117	E6	F2	IC-362
U114	GPIB Transceiver, 75161	G3	D2	IC-299
U115	GPIB Transceiver, 75160	G2	E2	IC-298
VR101	Diode, Band gap reference, 1.23V	B5	C2	DZ-65*
VR102	Diode, Zener, 5.1V	A3	C3	DZ-59
VR103	Diode, Zener, 5.1V	A3	C3	DZ-59
VR104	+ 5V Regulator, LM340A	D5	E3	IC-93
	Heat Sink for VR104	—	F3	HS-28
Y101	Crystal, 4.0MHz	C3	D1	CR-10

*Static Sensitive Device