

**Tektronix**<sup>®</sup>  
COMMITTED TO EXCELLENCE

# Instructions

## P6458

### P6458 ACQUISITION CONTROL PROBE

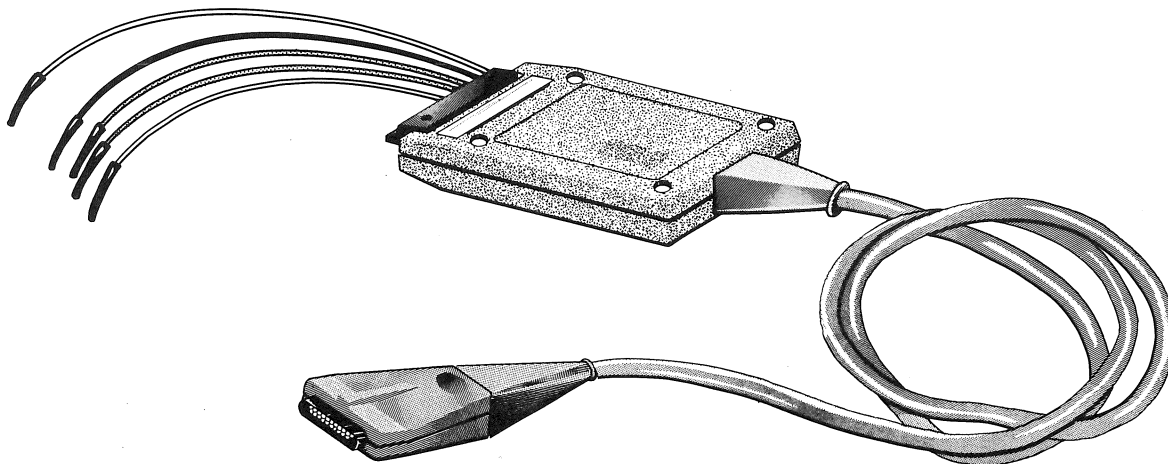

3619-1

#### DESCRIPTION

The P6458 Acquisition Control Probe is a 4-channel active probe for use with the SA 501 Signature Analyzer. The P6458 contains a hybrid integrated circuit that has four FET amplifiers with differential ECL outputs. All input channels of the hybrid circuits are protected from damage by static discharges. The high input resistance and low input capacitance of the probe allows the circuit under test to perform close to normal operating conditions, with minimal loading.

Probe input threshold levels are established by a voltage source supplied by the test instrument. The P6458 outputs are compatible with test instruments having differential ECL receivers (e.g., types 10115 or 10216) with 100  $\Omega$  differential-input termination. DC power for operating the probe circuitry is derived from the associated instrument via the probe connector. The broad input range of the P6458 permits its use with a wide variety of input signal levels.

This instrument is listed with Underwriters Laboratories, Inc., under UL Standard 1244 (Electrical and Electronic Measuring and Test Equipment).

A Tektronix Lead Set (see Standard Accessories) is provided with the probe and standard accessories package. The five input leads (four signals plus one common ground connector) are each 9 inches long and are molded into a common plug-in connector that plugs into the probe body. Five microcircuit test probe tips are supplied with the input lead set to provide a convenient means of attaching the inputs to the circuitry under test. The individual signal leads are each color-coded to permit easy identification when making connections.

## SPECIFICATION

### Electrical Characteristics

Characteristics	Information
Input Resistance	1 M $\Omega$ , $\pm$ 50 k $\Omega$ .
Input Capacitance	5 pF, $\pm$ 1 pF (without input leads).
Maximum Input Threshold Control Voltage	–16.25 V to +3.25 V with Hybrid powered from –5 V. –10 V to +10 V with Hybrid powered from +5 V.
Maximum Dynamic Input Voltage	–40 V to a maximum of 10 V above input threshold level. –40 V to a maximum of 30 V above input threshold level for RS 232 signals only.
Maximum Nondestructive Voltage to Input	40 V (dc + peak ac).
Delay Time	17 ns $\pm$ 2 ns with $\pm$ 1 V input signal and threshold at 0 V.
Power Requirements	
Voltage	4.7 V to 5.3 V.
Current	140 mA or less at 5 V.

### Environmental Characteristics

Characteristics	Information
Temperature	
Storage	–55°C to +75°C.
Operating	0°C to +50°C.
Altitude	
Storage	To 50,000 feet.
Operating	To 15,000 feet.

### Physical Characteristics

Characteristics	Information
Weight (Probe Only)	204 grams (7.1 ounces).
Length	
Probe Head and Cable	2 meters (6.5 feet).
Input Lead Set (10-wide)	25 centimeters (9.8 inches).

## OPERATING CONSIDERATIONS

Use of the P6458 as part of a logic analysis system is covered in the associated logic analyzer instruction manual. The instructions in this section relate mainly to the various means of connecting the P6458 into the circuitry under test.

### Probe Cable Connector

The miniature 25-pin connector at the end of the probe cable should be carefully inserted into one of the associated test instrument connectors.

**CAUTION**

*Make sure that the probe cable connector is correctly aligned with the test instrument connector. Damage to the terminals can result from forcing one connector into another.*

### Probe Input Leads

The five probe input leads, individually color coded for easy identification of channels, are molded into a common-connector at the output end (see Figure 1). To connect this assembly to the probe head, carefully push the 5-terminal plug into the socket on the probe head. Be sure the correct sides of the probe head and plug assembly are facing upward as illustrated. To remove the input-lead set, hold the probe head and pull the assembly plug straight out away from the probe head.

To minimize the pickup of electromagnetic interference, input leads should be kept as short as possible. However, to avoid adding errors to critical timing measurements, input leads should all be the same length.

### Input Lead Color Coding

The probe input leads are color-coded as follows:

Channel	Color
Ground	White
0	Black
1	Brown
2	Red
3	Orange

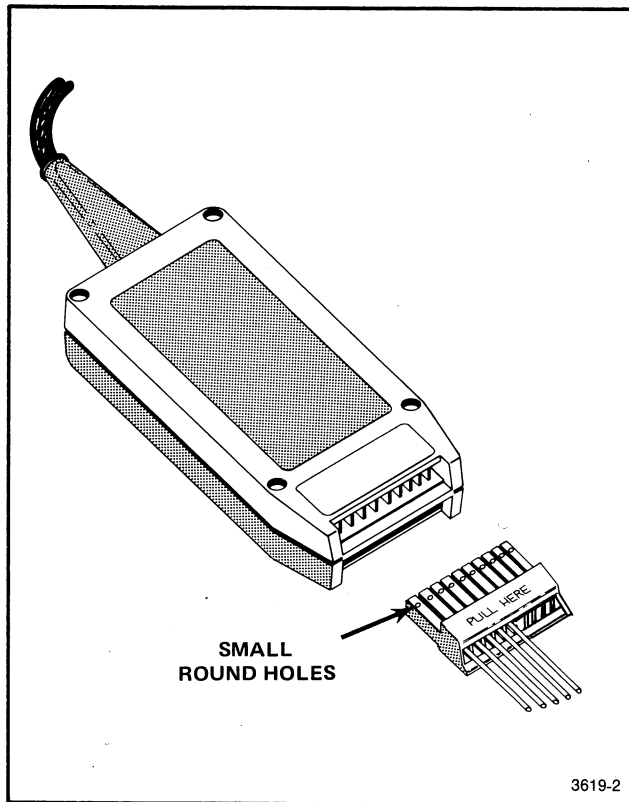

Figure 1. Installation of 5-wide input lead set.

### Connecting Probe Input Leads to Circuitry

A set of five plug-on microcircuit-test probe tips is supplied as a standard accessory to the P6458. The probe tips can be attached to the test leads by pushing the lead end onto the recessed round pin near the butt end of the probe tip (see Figure 2). Make sure that the round pin on the probe tip and the connector on the end of the test lead are properly aligned to prevent damage.



*To avoid damage to the probe, do not connect the ground lead to a voltage source above or below ground reference.*

Each probe tip has a retractable hook that grasps a lead, wire, or connector firmly (see Figure 3). To use the retractable probe tip, push in the base of the probe tip until the hook appears (see Figure 4). Slip the hook over a lead or connector and release the tip base. The hook will retract and grip the connection firmly.

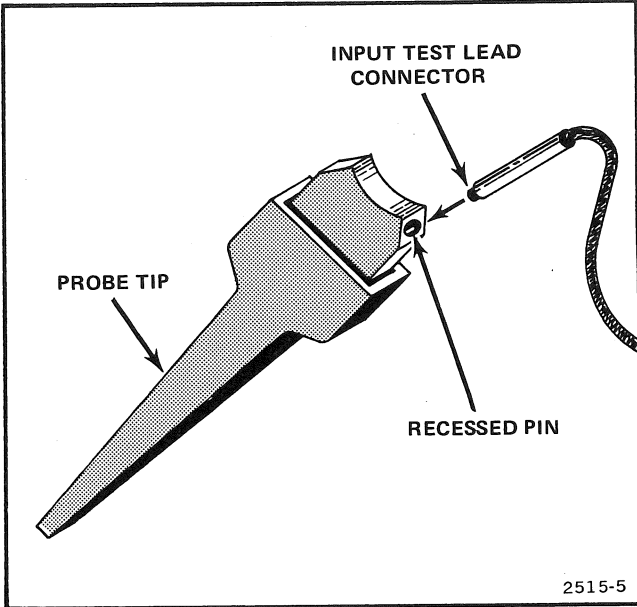

Figure 2. Connection of input lead to probe tip.

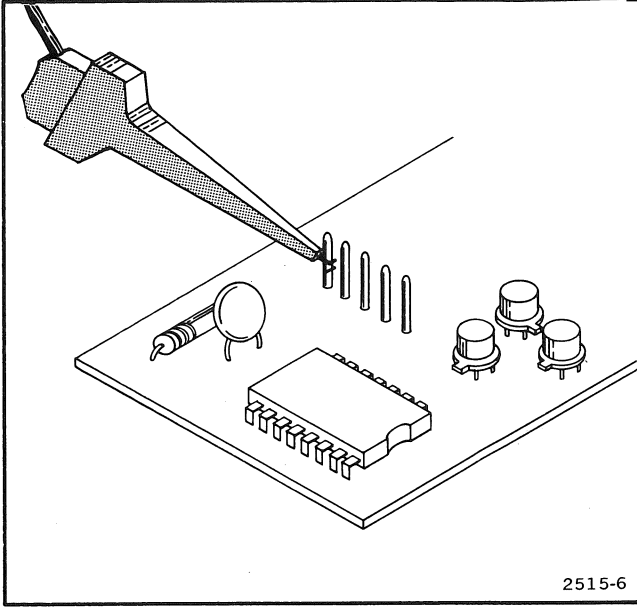

Figure 3. Attaching the retractable hook tip.

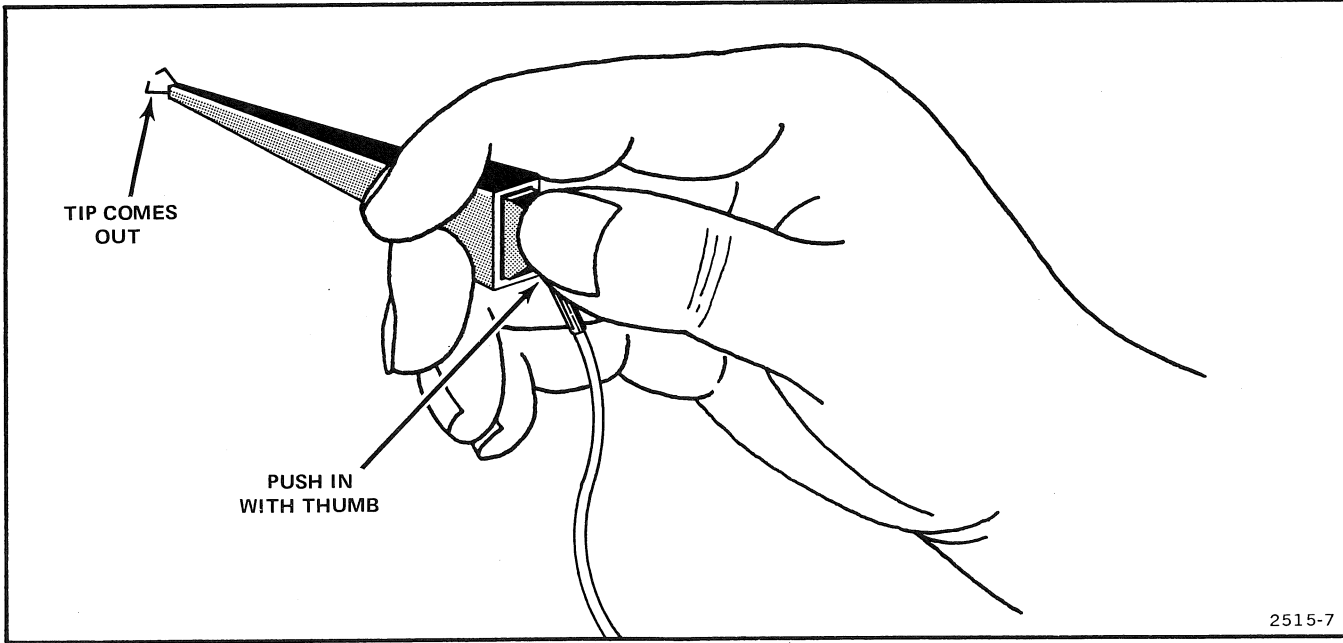

Figure 4. Operation of retractable hook tip.

## P6458 Acquisition Control Probe

Where several probe tips are to be connected close together in a compact area, the probe tips can be attached vertically onto 0.020 to 0.034 inch round pin connectors or 0.025 inch square pins. Open the hook by pressing the base of the probe tip and then slide the tip end down onto the round or square pin (see Figure 5).

Where space is even more restricted for making connections, pull the test lead out of the retractable hook tip and slide the connector end of the test lead down onto the round or square pin (the lead connector also fits onto 0.025 inch square pins and round pins from 0.020 to 0.034 inch). See Figure 6.

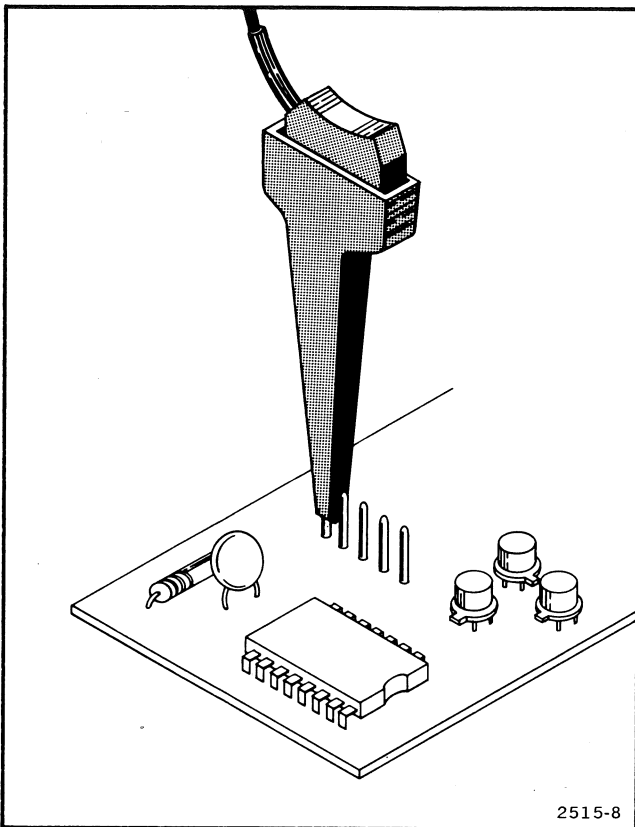

Figure 5. Attaching the hook tip vertically onto a pin connector.

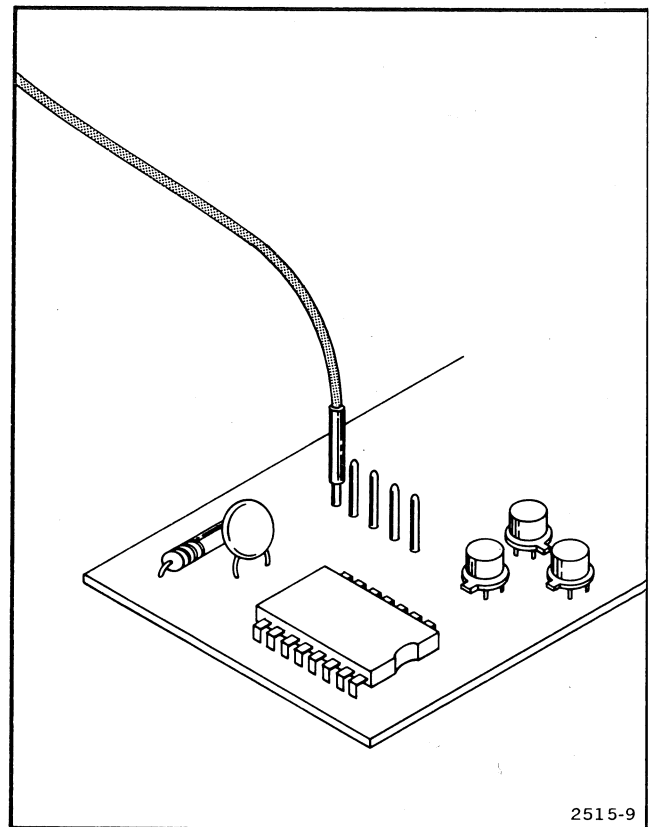

Figure 6. Attaching an input test lead connector onto a pin connector.

## MAINTENANCE

### WARNING

*The following servicing instructions are for use by qualified personnel only. To avoid personal injury, do not perform any servicing other than that contained in the operating instructions unless you are qualified to do so.*

The P6458 Probe is designed to withstand normal operation and handling. However, if the probe fails or is damaged, replacement parts are available. See the Replacement Parts List for descriptions and part numbers.

### Cleaning

Dirt that accumulates on the probe head can be removed with a soft cloth dampened in a mild detergent and water solution. Abrasive cleaners should not be used.

### CAUTION

*Avoid the use of chemical cleaning agents which might damage the plastics used in this instrument. In particular, avoid chemicals which contain benzene, toluene, xylene, acetone or similar solvents.*

*Recommended cleaning agents are isopropyl alcohol (Isopropanol) or ethyl alcohol (Fotocol or Ethanol).*

Contaminated contact areas of the connectors, hybrids, and circuit board can be cleaned with a cotton-tipped applicator dipped in a recommended cleaning agent (above).

### Probe Head Component Access

### CAUTION

*Do not remove hybrid frames*

1. Remove the four corner screws and nuts which hold the probe halves together.
2. While pulling the probe body halves apart, note which half covers which side of the circuit board.

See Figure 7 for component locations on the circuit board; and see Figure 8 for probe head cable connections.

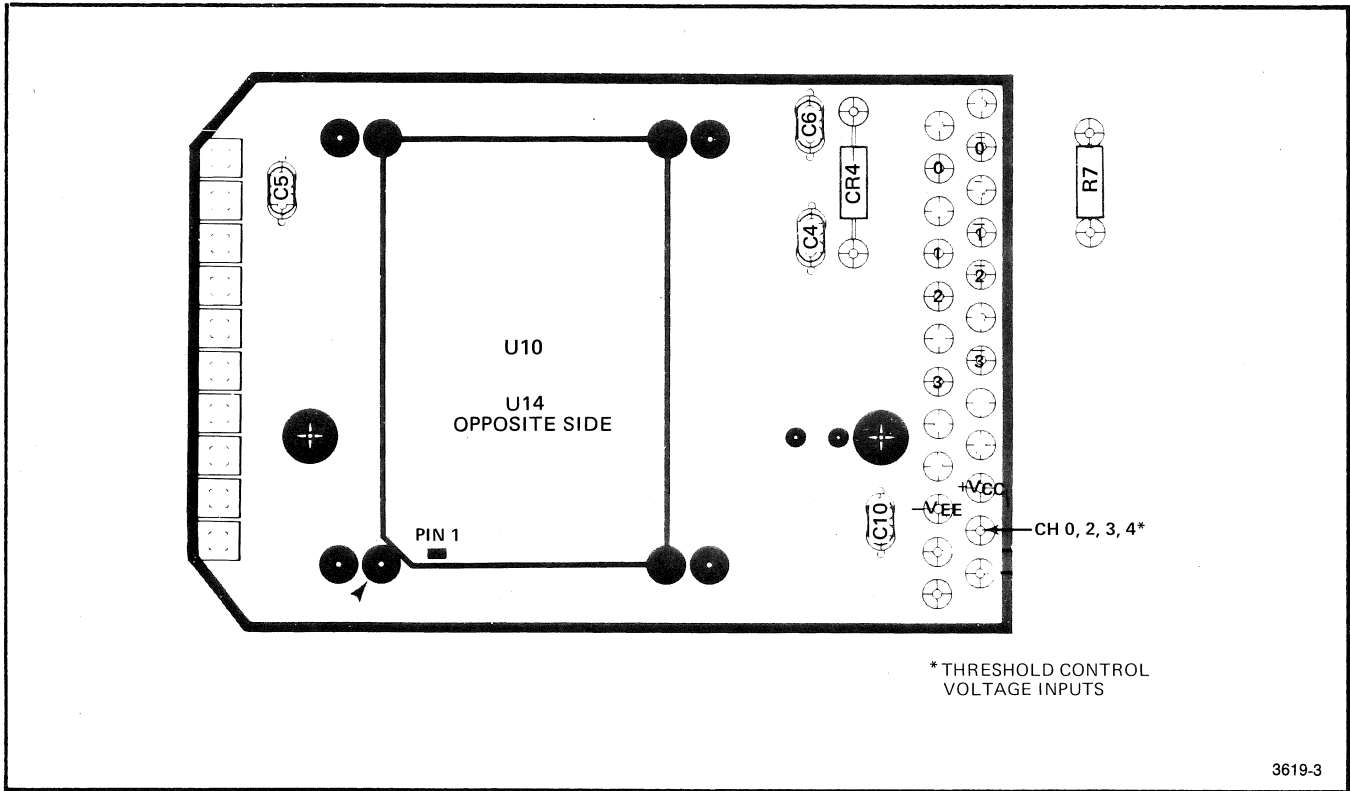

Figure 7. Component locations on the circuit board.

3. Replace any defective components.
4. When reinstalling the circuit board in probe body, be sure that the body half with channel identification label covers the circuit board side with the channel input pins.
5. Replace the four screws that hold the probe body halves together.

## Troubleshooting

### Equipment Required

- Test Oscilloscope
- Function Generator
- Power Supply

The following information is provided to aid in troubleshooting the P6458. Troubleshooting information contained in the associated test-instrument instruction manual should be used with the following information in locating malfunctions.

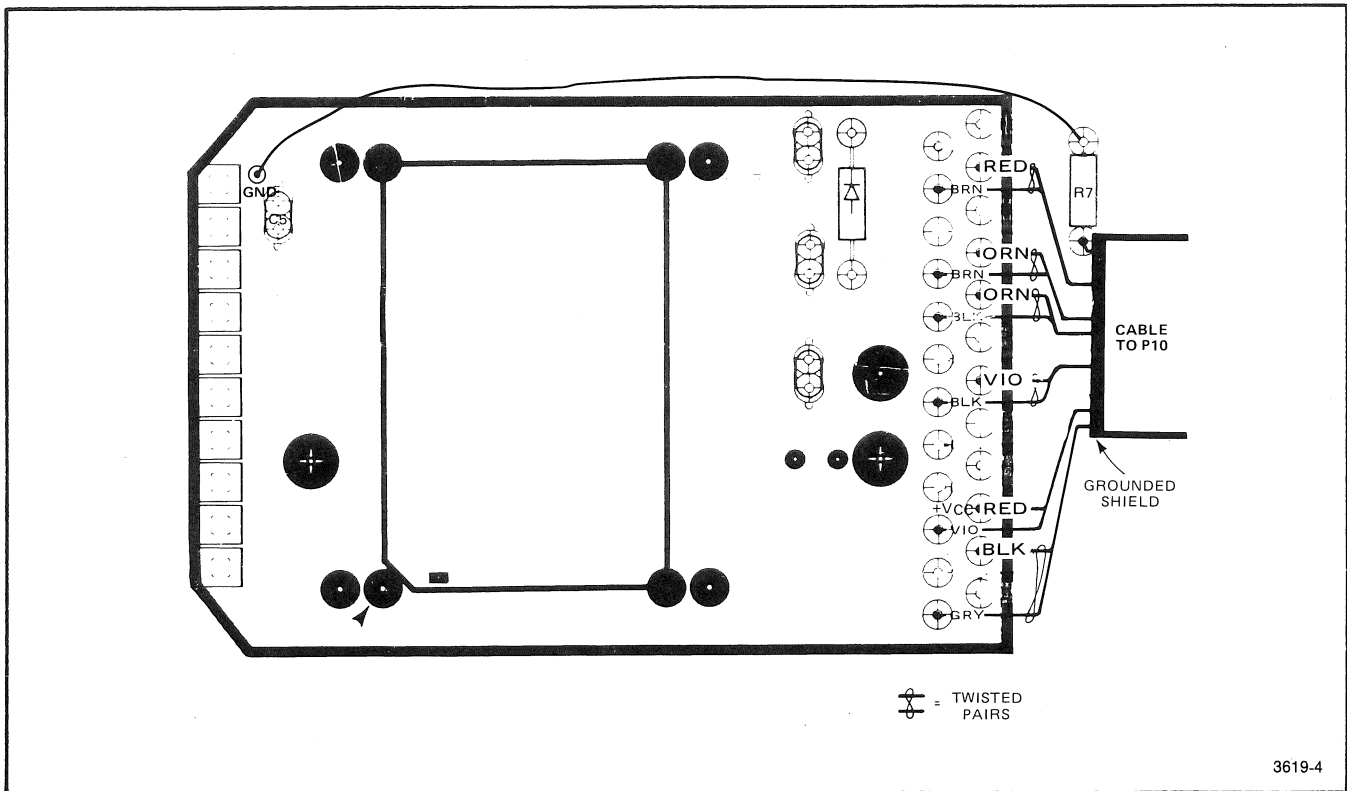

Figure 8. Probe head cable connections.

**1. Isolate Trouble to a Circuit.** To determine if the trouble is in the probe or the test instrument, use the troubleshooting information in the instruction manual for the test equipment. If the probe is found to be defective, proceed with step 2.

**2. Visual Check.** Remove the two halves of the probe body (refer to the Probe Head Component Access procedure, above). Check the probe for visible indications of a defect. Look for broken wires, damaged circuit board, damaged components, etc. Repair or replace any such defective parts. If there are no visible indications of a defect, proceed with step 3.

**3. Check Supply Voltage.** The supply voltage to the P6458 can have various values depending upon the voltage level used in the test instrument. Refer to the probe schematic and the test equipment instrument instruction manual for the supply voltage assigned to the probe.

If all the channels are affected by the trouble, check supply voltages, VCC, VDD, and VEE. If one or more of the channels are operating correctly, proceed with step 4.

**NOTE**

*Supply voltages are measured with respect to the test instrument chassis ground.*

## P6458 Acquisition Control Probe

**+VCC = Chassis Ground    -VEE = Chassis Ground**

Typical Voltage

+VCC = 0 V

+VDD = -0.5 V

-VEE = -5 V

Typical Voltage

+VCC = +5 V

+VDD = +4.5 V

-VEE = 0 V

a. If VCC does not have its assigned voltage, check the VCC cable wire (red) for continuity. If wire shows no continuity, proceed to step 5.

b. If VEE does not have its assigned voltage, check the VEE cable wire (violet) for continuity. If wire shows no continuity, proceed to step 5.

c. If the voltage at VDD is the same as VEE, check diode CR4 for an open. If the diode is open, replace it.

d. If the voltage at VDD is the same as VCC, check diode CR4 for a short. If the diode is shorted, replace it.

**4. Check Hybrid Operation.** If the supply voltages are correct, check for a defective channel on one of the hybrids.

a. Set the input threshold level of the test instrument to zero volts.

b. Connect a signal lead from a channel input on the probe to a 1 kHz square wave of +1 volt to -1 volt (use a function generator).

c. With a test oscilloscope, check the + (plus) output (noninverting) and - (minus) output (inverting) at the cable connector and at the circuit board for the correct output waveform (see Figure 9 for typical waveforms).

See Figure 8 for cable connections at the circuit board; and Figure 10 for output connector assignments.

d. If an output signal is present on the circuit board, but not at the cable connector, check the cable wire for continuity.

e. If there is no signal at any of the circuit board connections, suspect the hybrid. If the hybrid is found to be defective, proceed to step 5.

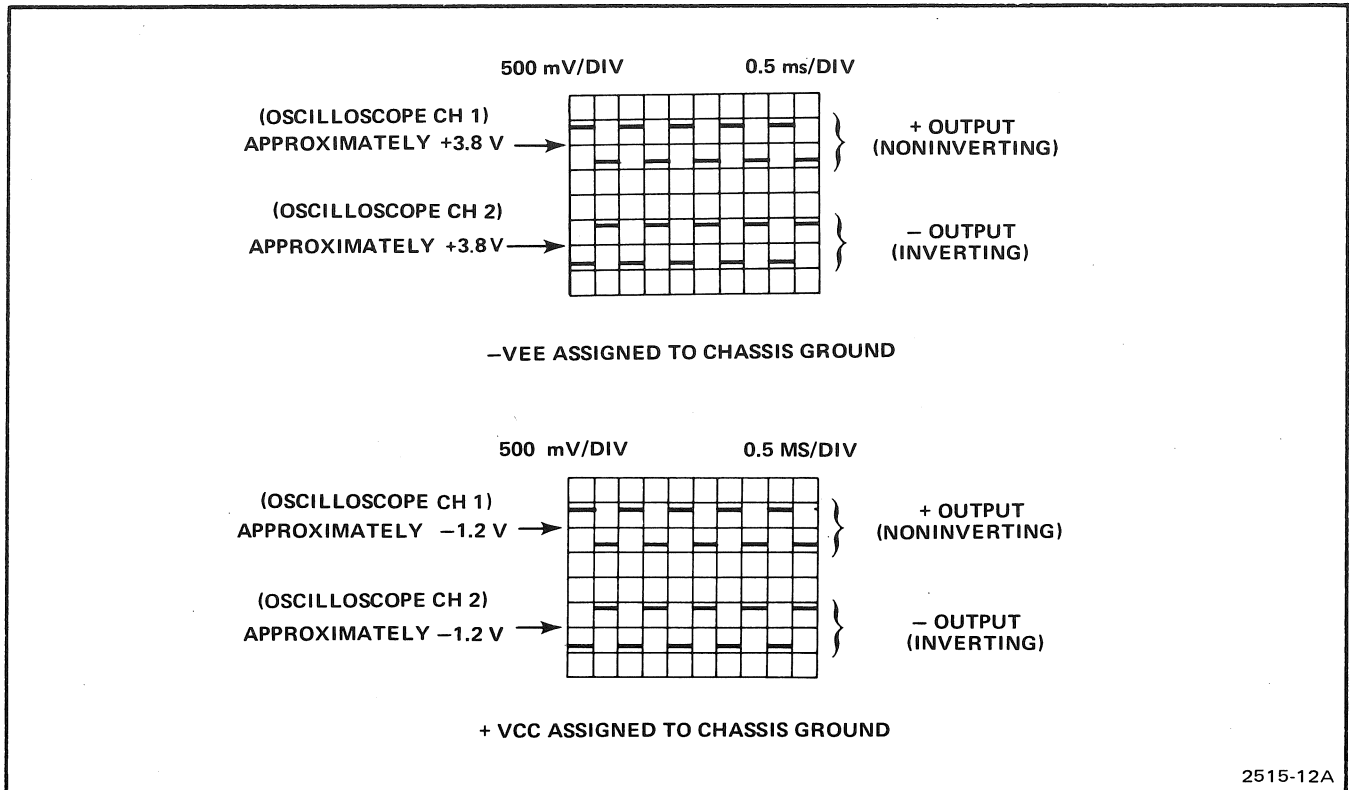

Figure 9. Typical channel output waveforms vs. supply voltage assigned.

**5. Replacement of Parts.** If one of the hybrid integrated circuits is defective, or if the circuit board is damaged, a wired circuit board with components is available. See the Replaceable Parts List for Tektronix part numbers of available components. Electrical replaceable components are called out by component number on Figure 7. The Replaceable Electrical Parts list contains reference to circuit numbers, and components are also called out by index numbers in the Replaceable Mechanical Parts list.

**6. Obtaining Replaceable Parts.** All electrical and mechanical part replacements for the P6458 Probe can be obtained through your local Tektronix Field Office or representative.

When ordering replacement parts from Tektronix, Inc., include the following information:

- a. Instrument type.
- b. Instrument date code.
- c. A description of the part (if electrical, include circuit number; for example, CR4).
- d. Tektronix part number.

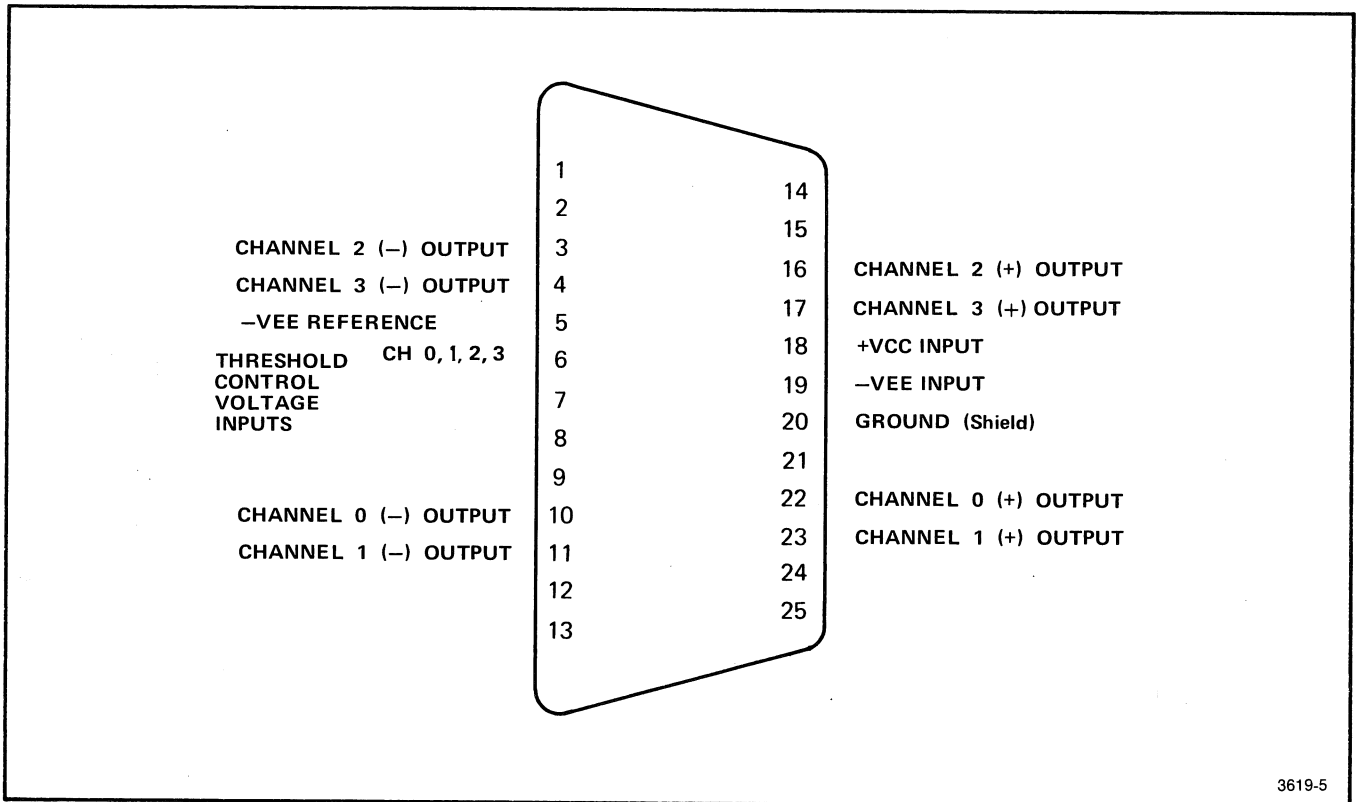

3619-5

Figure 10. Probe output connector pin assignment (P10, end view).

### Service Available

Tektronix, Inc. provides complete instrument repair and calibration at Field Service centers and at the Factory Service Center. Contact your nearest Tektronix Field Office or representative for more information or assistance on troubleshooting.

# REPLACEABLE PARTS

## PARTS ORDERING INFORMATION

Replacement parts are available from or through your local Tektronix, Inc. Field Office or representative.

Changes to Tektronix instruments are sometimes made to accommodate improved components as they become available, and to give you the benefit of the latest circuit improvements developed in our engineering department. It is therefore important, when ordering parts, to include the following information in your order: Part number, instrument type or number, serial number, and modification number if applicable.

If a part you have ordered has been replaced with a new or improved part, your local Tektronix, Inc. Field Office or representative will contact you concerning any change in part number.

Change information, if any, is located at the rear of this manual.

## SPECIAL NOTES AND SYMBOLS

- X000 Part first added at this serial number
- 00X Part removed after this serial number

## FIGURE AND INDEX NUMBERS

Items in this section are referenced by figure and index numbers to the illustrations.

## INDENTATION SYSTEM

This mechanical parts list is indented to indicate item relationships. Following is an example of the indentation system used in the description column.

```

1 2 3 4 5           Name & Description
Assembly and/or Component
Attaching parts for Assembly and/or Component
    ---*---
Detail Part of Assembly and/or Component
Attaching parts for Detail Part
    ---*---
Parts of Detail Part
Attaching parts for Parts of Detail Part
    ---*---
    
```

Attaching Parts always appear in the same indentation as the item it mounts, while the detail parts are indented to the right. Indented items are part of, and included with, the next higher indentation. The separation symbol ---\*--- indicates the end of attaching parts.

**Attaching parts must be purchased separately, unless otherwise specified.**

## ITEM NAME

In the Parts List, an Item Name is separated from the description by a colon (:). Because of space limitations, an Item Name may sometimes appear as incomplete. For further Item Name identification, the U.S. Federal Cataloging Handbook H6-1 can be utilized where possible.

## ABBREVIATIONS

"	INCH	ELCTRN	ELECTRON	IN	INCH	SE	SINGLE END
#	NUMBER SIZE	ELEC	ELECTRICAL	INCAND	INCANDESCENT	SECT	SECTION
ACTR	ACTUATOR	ELCTLT	ELECTROLYTIC	INSUL	INSULATOR	SEMICOND	SEMICONDUCTOR
ADPTR	ADAPTER	ELEM	ELEMENT	INTL	INTERNAL	SHLD	SHIELD
ALIGN	ALIGNMENT	EPL	ELECTRICAL PARTS LIST	LPHLDR	LAMPHOLDER	SHLDR	SHOULDERED
AL	ALUMINUM	EQPT	EQUIPMENT	MACH	MACHINE	SKT	SOCKET
ASSEM	ASSEMBLED	EXT	EXTERNAL	MECH	MECHANICAL	SL	SLIDE
ASSY	ASSEMBLY	FIL	FILLISTER HEAD	MTG	MOUNTING	SLFLKG	SELF-LOCKING
ATTEN	ATTENUATOR	FLEX	FLEXIBLE	NIP	NIPPLE	SLVG	SLEEVEING
AWG	AMERICAN WIRE GAGE	FLH	FLAT HEAD	NON WIRE	NOT WIRE WOUND	SPR	SPRING
BD	BOARD	FLTR	FILTER	OBD	ORDER BY DESCRIPTION	SQ	SQUARE
BRKT	BRACKET	FR	FRAME or FRONT	OD	OUTSIDE DIAMETER	SST	STAINLESS STEEL
BRS	BRASS	FSTNR	FASTENER	OVH	OVAL HEAD	STL	STEEL
BRZ	BRONZE	FT	FOOT	PH BRZ	PHOSPHOR BRONZE	SW	SWITCH
BSHG	BUSHING	FXD	FIXED	PL	PLAIN or PLATE	T	TUBE
CAB	CABINET	GSKT	GASKET	PLSTC	PLASTIC	TERM	TERMINAL
CAP	CAPACITOR	HDL	HANDLE	PN	PART NUMBER	THD	THREAD
CER	CERAMIC	HEX	HEXAGON	PNH	PAN HEAD	THK	THICK
CHAS	CHASSIS	HEX HD	HEXAGONAL HEAD	PWR	POWER	TNSN	TENSION
CKT	CIRCUIT	HEX SOC	HEXAGONAL SOCKET	RCPT	RECEPTACLE	TPG	TAPPING
COMP	COMPOSITION	HLCPS	HELICAL COMPRESSION	RES	RESISTOR	TRH	TRUSS HEAD
CONN	CONNECTOR	HLEXT	HELICAL EXTENSION	RGD	RIGID	V	VOLTAGE
COV	COVER	HV	HIGH VOLTAGE	RLF	RELIEF	VAR	VARIABLE
CPLG	COUPLING	IC	INTEGRATED CIRCUIT	RTNR	RETAINER	W/	WITH
CRT	CATHODE RAY TUBE	ID	INSIDE DIAMETER	SCH	SOCKET HEAD	WSHR	WASHER
DEG	DEGREE	IDNT	IDENTIFICATION	SCOPE	OSCILLOSCOPE	XFMR	TRANSFORMER
DWR	DRAWER	IMPLR	IMPELLER	SCR	SCREW	XSTR	TRANSISTOR

**P6458 Acquisition Control Probe**

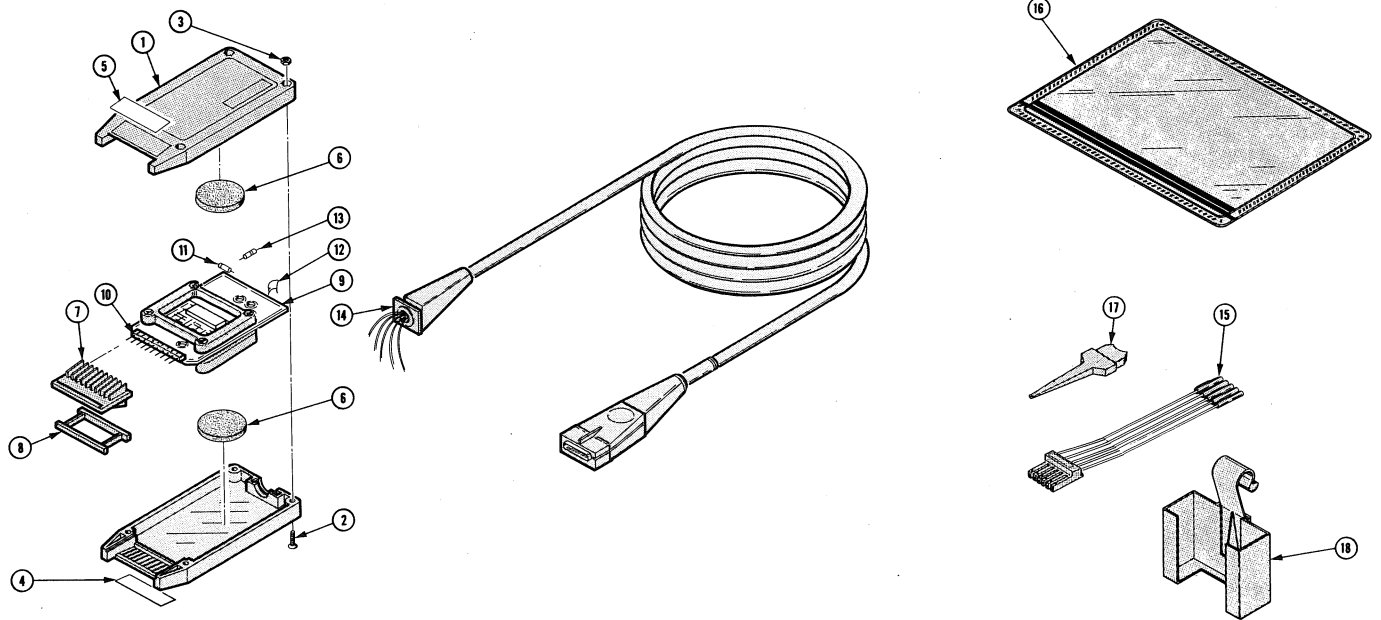

Fig. & Index No.

Fig. & Index No.	Tektronix Part No.	Serial/Model No. Eff Dscont	Qty	1	2	3	4	5	Name & Description	Mfr Code	Mfr Part Number
1-	010-6458-00		1						PROBE, ACQ. CONT:	80009	010-6458-00
-1	380-0463-00		2						HOUSING, PROBE:	80009	380-0463-00
									(ATTACHING PARTS)		
-2	211-0106-00		4						SCREW, MACHINE: 4-40 X 0.625" 100 DEG, FLH, STL	83385	OBD
-3	210-0406-00		4						NUT, PLAIN, HEX.: 4-40 X 0.188 INCH, BRS	73743	2X12161-402
									- - - * - - -		
-4	334-5003-00		1						PLATE, IDENT: TEKTRONIX ACQ. CONT. PROBE	80009	334-5003-00
-5	334-5005-00		1						PLATE, IDENT:	80009	334-5005-00
-6	348-0123-00		2						PAD, CUSHIONING: 1.0 DIA X 0.125	85471	OBD
-7	361-0758-00		1						SPACER, PROBE:	80009	361-0758-00
-8	361-0772-00		1						SPACER, COVER: PROBE	80009	361-0772-00
-9	670-7080-00		1						CIRCUIT BOARD ASSY: DATA ACQUISITION	80009	670-7080-00
-10	131-1811-00		1						TERM SET, PIN: 10, 0.025 SQ ON 0.15 CTR	22526	65595-110
-11	152-0075-00		1						SEMICON DEVICE: GE, 22V, 40MA (CRO004)	14433	G866
-12	283-0220-00		4						CAP., FXD, CER DI: 0.01UF, 20%, 50V (C0004, C0005, C0006, C0010)	72982	8121N075X7R0103M
	-----										
-13	315-0100-00		1						RES., FXD, CMPSN: 10 OHM, 5%, 0.25W (R070)	01121	CB1005
-14	175-3782-01		1						CA ASSY, SP, ELEC: 5, 32 AWG TW PR & 2, 28 AWG	80009	175-3782-01
									STANDARD ACCESSORIES		
	020-0639-00		1						ACCESSORY PKG:	80009	020-0639-00
-15	012-0942-00		1						LEAD SET, ELEC: 5 WIDE, 9.843 L	80009	012-0942-00
-16	016-0537-00		1						POUCH, ACCESSORY: VINYL, W/ZIPPER	05006	OBD
-17	206-0222-00		5						TIP, PROBE: MICROCIRCUIT TEST	80009	206-0222-00
-18	352-0473-01		1						HOLDER, PROBE: W/HANGER	80009	352-0473-01
	070-3619-00		1						SHEET, TECHNICAL: INSTRUCTION	80009	070-3619-00

**CROSS INDEX—MFR. CODE NUMBER TO MANUFACTURER**

Mfr. Code	Manufacturer	Address	City, State, Zip
01121	ALLEN-BRADLEY COMPANY	1201 2ND STREET SOUTH	MILWAUKEE, WI 53204
05006	TWENTIETH CENTURY PLASTICS, INC.	415 E WASHINGTON BLVD.	LOS ANGELES, CA 90015
14433	ITT SEMICONDUCTORS	3301 ELECTRONICS WAY P O BOX 3049	WEST PALM BEACH, FL 33402
22526	BERG ELECTRONICS, INC.	YOUK EXPRESSWAY	NEW CUMBERLAND, PA 17070
72982	ERIE TECHNOLOGICAL PRODUCTS, INC.	644 W. 12TH ST.	ERIE, PA 16512
73743	FISCHER SPECIAL MFG. CO.	446 MORGAN ST.	CINCINNATI, OH 45206
80009	TEKTRONIX, INC.	P O BOX 500	BEAVERTON, OR 97077
83385	CENTRAL SCREW CO.	2530 CRESCENT DR.	BROADVIEW, IL 60153
85471	BOYD, A. B., CO.	2527 GRANT AVENUE	SAN LEANDRO, CA 94579

