

**LOW-LEVEL  
DIFFERENTIAL AC PREAMP  
TYPE E  
INSTRUCTION  
MANUAL**



**TEKTRONIX, INC.**  
**MANUFACTURERS OF CATHODE-RAY AND VIDEO TEST INSTRUMENTS**

---

**Sunset Highway and Barnes Road • P. O. Box 831 • Portland 7, Oregon, U. S. A.**  
**Phone: CYPRESS 2-2611 • Cables: Tektronix**

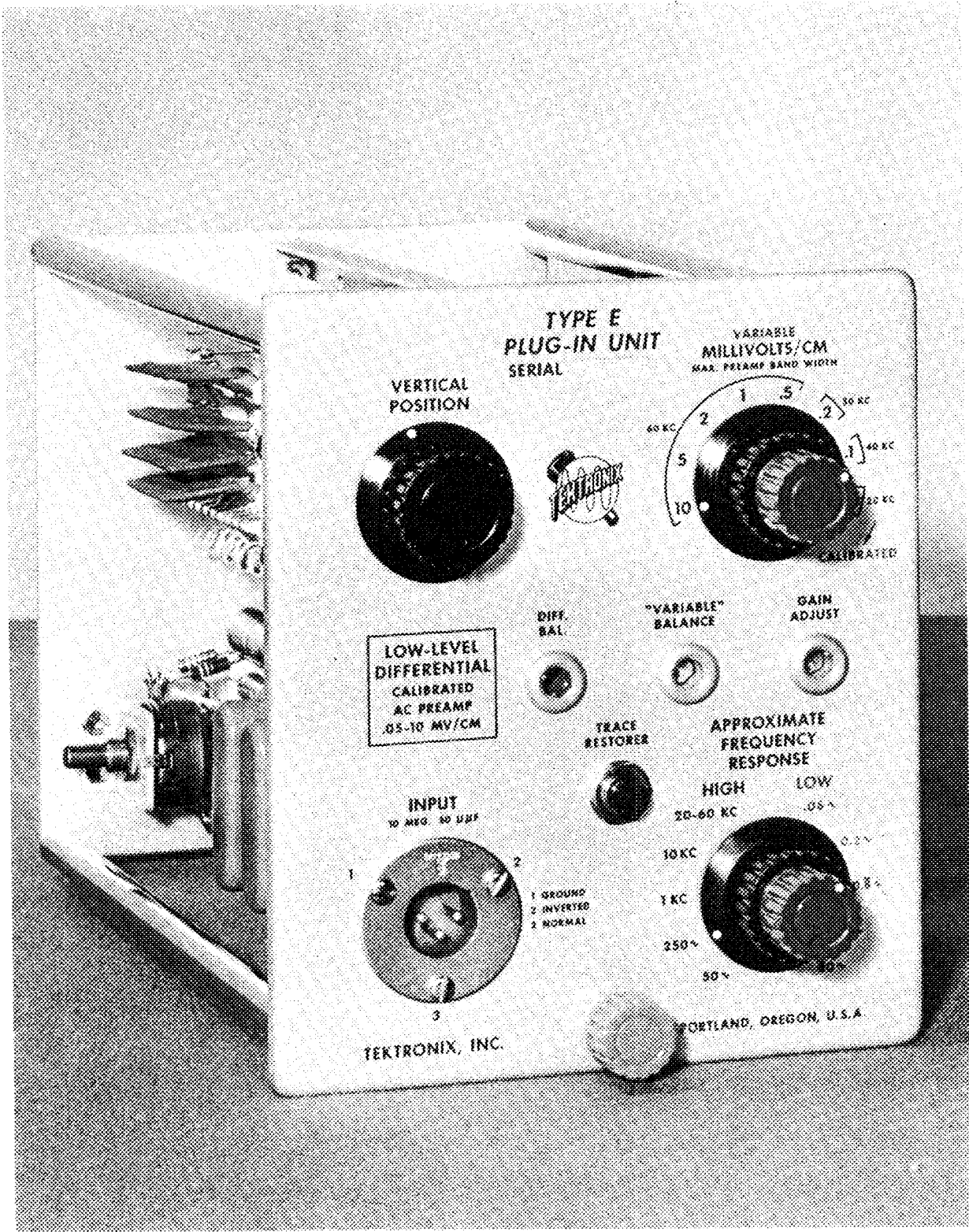

**TYPE E  
PLUG-IN UNIT**  
SERIAL

VERTICAL  
POSITION

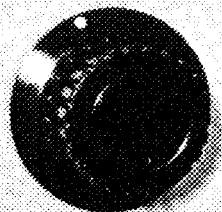

VARIABLE  
MILLIVOLTS/CM  
MAX. PREAMP BAND WIDTH

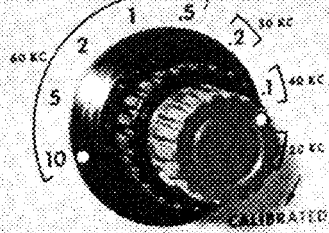

LOW-LEVEL  
DIFFERENTIAL  
CALIBRATED  
AC PREAMP  
0.5-10 MV/CM



APPROXIMATE  
FREQUENCY  
RESPONSE

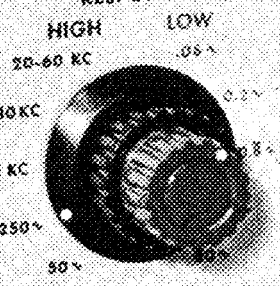
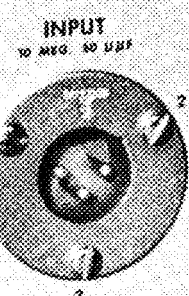

TEKTRONIX, INC.

PORTLAND, OREGON, U.S.A.

## GENERAL DESCRIPTION

### General

The Type E Plug-in Unit is a high-gain adjustable bandwidth, ac-coupled preamplifier. Calibrated vertical sensitivities to 50 microvolts per centimeter in conjunction with differential input extended the capabilities of the 530- and 540-Series Oscilloscopes into a new region of usefulness.

### Characteristics

#### SIGNAL INPUT

Both grids of the push-pull input stage and ground are brought out to the 3-pin INPUT connector. Thus, single-ended or differential input may be used by merely making the proper grid and ground connections.

### SENSITIVITY

.05 millivolts/cm to 10 millivolts/cm in eight calibrated positions. Continuously variable between the fixed positions and to 25 millivolts/cm.

### FREQUENCY RESPONSE

Adjustable high- and low-frequency response having the following 3-db points:

High: 50 cps, 250 cps, 1 kc, 10 kc, 20 to 60 kc  
Low: 0.06 cps, 0.2 cps, 0.8 cps, 8 cps, 80 cps

### PHYSICAL CHARACTERISTICS

Construction, aluminum alloy chassis; finish, photo-etched, anodized panel; weight, 4½ lbs.

### Functions of Controls and Connectors

<b>INPUT</b>	3-pin connector for signal input connections. Pin 1, ground. Pin 2, positive input produces negative output. Pin 3, positive input produces positive output.
<b>VERTICAL POSITION</b>	Potentiometer to move the trace vertically.
<b>MILLIVOLTS/CM</b>	Eight-position switch to select the calibrated vertical deflection sensitivities.
<b>VARIABLE</b>	Control concentric with the <b>MILLIVOLTS/CM</b> switch for varying the deflection sensitivity between the fixed steps and to 25 millivolts/cm.
<b>DIFF. BAL.</b>	Screwdriver-adjust control used to obtain maximum in-phase signal rejection when using differential input.
<b>"VARIABLE" BALANCE</b>	Screwdriver-adjust control to balance the attenuator stage dc levels so the trace does not shift position as the <b>VARIABLE</b> control is rotated.
<b>GAIN ADJUST</b>	Screwdriver-adjust control used to set the gain of the preamplifier so the crt deflection will agree with the <b>MILLIVOLTS/CM</b> sensitivities.
<b>TRACE RESTORER</b>	This push button switch, when operated, discharges the last set of coupling capacitors and returns the trace to the face of the crt.
<b>APPROXIMATE FREQUENCY RESPONSE</b>	Concentric switches to select the upper and lower 3 db points of the amplifier pass band.



## OPERATING INSTRUCTIONS

**NOTE:** Remove the shipping blocks from the shock mounts before operating this preamp.

### General

Allow the Type E Plug-In Unit to warm up for several minutes before attempting to use it. This is a very high gain unit and the initial drift will probably keep the trace off the crt screen for a short time. This initial drift can be minimized by setting the red **FREQUENCY RESPONSE** knob to 80. If, after the preamp has stabilized, a switching transient or bad connection causes the trace to be deflected by operating the **TRACE RESTORER** push button.

### Signal Input Connections

This preamp is designed for single-ended or differential input. Each of the grids of the balanced input stage is brought out to the front panel to a 3-pin connector labeled **INPUT**. Pins 2 and 3 are the signal connections and pin 1 is the chassis ground. Matching female connectors are available through the Tektronix Customer Service Department. Order by Tektronix Part Number 012-022. The input impedance of either grid is 10 megohms shunted by 50  $\mu\text{f}$ . The grid-to-grid impedance is 20 megohms shunted by 50  $\mu\text{f}$ .

There are no blocking capacitors in the input connections. If signals having a dc component greater than two volts are connected to the preamp, an external blocking capacitor must be used.

### Single-Ended Input

Either of the two grids can be used for single-ended input. A positive-going signal on pin 3 of the **INPUT** connector will produce a normal display on the crt screen. Signals connected to pin 2 will produce an inverted display. In either case, the unused signal grid must be grounded. Normally this should be done by connecting the unused pin directly to pin 1 at the **INPUT** connector. However, if there is hum introduced in the connecting cable, this can sometimes be reduced by grounding the unused grid at the input to the cable.

### Differential Input

In many applications the desired signal is superimposed on an undesired signal such as

line-frequency hum, etc. By use of differential input you can, in many cases, improve the ratio of the desired to undesired signal. If you can make a connection to the pin-3 input with both the desired and undesired signals and to the pin-2 input with only the undesired signal, the undesired signal will be attenuated by outphasing. If the **DIFF. BAL.** control is properly adjusted and the undesired signals are exactly in phase, the undesired signal will be reduced by a ratio of about 50,000 to 1. The maximum common-mode signal amplitude that can be satisfactorily attenuated is about two volts, peak to peak.

By using the same connection you can display push-pull signals. Again you should observe the proper input polarity to avoid an inverted display.

### Frequency Response

In addition to the differential rejection of unwanted signals, many times an undesired signal can be attenuated by varying the frequency response of the unit. An example of this would be a low-frequency sinusoidal waveform that is modulated by high-frequency noise. By reducing the high-frequency response the noise can, in many cases, be almost completely eliminated without distorting the desired signal. Likewise you might filter out undesired line-frequency hum by restricting the low-frequency response of the unit. Be careful not to distort non-sinusoidal waveforms by a too severe restriction of the amplifier's pass band.

### Deflection Sensitivity and Gain Adjust

The **MILLIVOLTS/CM** switch provides eight fixed deflection sensitivities. The maximum frequency response is limited in the three most sensitive positions as indicated, decreasing to 20 kc at .05 millivolts/cm. The **VARIABLE** control which is concentric with the **MILLIVOLTS/CM** switch, must be turned full right to the **CALIBRATED** position if you are to read signal amplitudes from the ruled graticule.

The gain of the unit should be checked periodically and, if necessary, readjusted to compensate for tube aging. Be sure the **VARIABLE** control is turned full right to the **CALIBRATED** position and display a signal of known amplitude such as the oscilloscope's calibrator waveform. Set the **GAIN ADJUST** control so the displayed signal amplitude agrees with the deflection sensitivity indicated by the **MILLIVOLTS/CM** switch.



### "Variable" Balance

As tubes age, their characteristics change, particularly their static characteristics. The **VARIABLE** gain control is connected between the cathodes of the tubes in the gain-control stage. Any difference in dc level between the two cathodes will cause the trace to shift vertically as the **VARIABLE** control is rotated. The "**VARIABLE**" **BALANCE** control is used to set the two cathodes to the same dc level to

remedy this condition. Rotate the **VARIABLE** control back and forth and adjust the "**VARIABLE**" **BALANCE** to the point where the trace does not shift position. If the "**VARIABLE**" **BALANCE** control is very far out of adjustment you will find it easier to restrict the low-frequency response of the unit and make a rough adjustment and then increase the low-frequency response to maximum and make a final fine adjustment.

## CIRCUIT DESCRIPTION

### General

The Type E Plug-In Unit has a maximum pass band of a fraction of a cycle to 60 kc. It consists of three stages of amplification with output cathode followers to drive the interconnecting plug. Voltage-regulator tubes further stabilize the regulated-supply voltages applied to the input-amplifier and gain-control stages.

### Input Amplifier

The input amplifier, V3015, is a cathode-coupled phase-inverter amplifier. The **DIFF. BAL.** control in the cathodes provides a means of balancing this stage for maximum rejection of in-phase signals on the grids. C3155, in one plate lead, balances the stray capacitance to ground in the plate leads for better high-frequency differential balance.

### Gain-Control Stage

The gain-control stage, V3205 and V3265, provides additional gain and gain control. The **MILLIVOLTS/CM** control selects fixed resistors for the plate loads of this stage to adjust the gain in fixed steps. The **VARIABLE** control, R3225, varies the gain of the stage between the fixed steps, and the **GAIN ADJUST** control sets the amplifier gain to agree with the front panel. The "**VARIABLE**" **BALANCE** control allows this stage to be balanced so there is no shift as the **VARIABLE** control is rotated.

The **LOW** frequency response switch selects coupling capacitors and grid resistors to select the desired low-frequency 3-db point.

### Positioning Amplifier

The positioning amplifier stage, V3805, provides additional gain and a means of positioning the trace vertically. The **VERTICAL POSITION** control, R3805, varies the current through each half of the balanced amplifier. Since the amplifier is dc coupled from this point on, this determines the average vertical position of the trace on the screen. The **VERT. POS. RANGE** control allows the balance to be adjusted so that the trace is centered when the **VERTICAL POSITION** control is centered.

The **HIGH** frequency response switch selects shunt capacitors to limit the high-frequency response of the preamp. In the **20-60 KC** position the switch contacts remain open for maximum frequency response.

The output cathode follower, V2905, provides the necessary low impedance to drive the interconnecting plug and oscilloscope input amplifier.

### Regulated Supplies

Regulated supplies in the oscilloscope supply all voltages used in the preamp including the heater voltage. Voltage-regulator tubes, V4005 and V4015 provide additional decoupling between the preamp and the oscilloscope.



# MAINTENANCE

## Replacement of Components

Tektronix will supply replacement components at current net prices. However, since most of the components are standard electronic and radio parts we suggest you get them from your local dealer if you can. Be sure to consult your instruction manual first to see what tolerances are required.

We specially select some of the components, whose values must fall within prescribed limits, by sorting through our regular stocks. The components so selected will have standard RETMA color-code marks showing the values and tolerances of the stock they were selected from, but they will not in general be replaceable from dealers stocks.

Such selected parts, as well as the parts we manufacture at Tektronix, are identified in the parts lists either by notes or by our own stock numbers. Order these parts from the Tektronix factory in Portland, Oregon.

## Parts-Ordering Information

You will find a serial number on the front-piece of this manual. This is the serial number of the instrument the manual was prepared for. Be sure the manual number matches the number of the instrument when you order parts.

A Tektronix instruction manual usually contains hand-made changes to diagrams and parts lists, and sometimes text. These changes are in general only appropriate to the instrument whose serial number appears on the manual front-piece. The hand-made changes show changes to the instrument that have been made after the printing of the manual.

We make some of the instrument changes during the factory test procedure. Our technicians hand-tailor the circuits, if it seems appropriate, to provide the widest possible latitude of operation. Other changes are made to include the latest circuit improvements as they are developed in our engineering department, or when improved components become available. In any event, the changes are to your benefit. We have tried to give you the best instrument we can.

## Soldering Precaution

The solder used on the ceramic terminals in this instrument must contain a small percentage of silver. If for any reason you resolder, be sure the solder you use contains silver. Silver-bearing solder is used in printed-circuit techniques, and

is therefore available from all solder manufacturers. Repeated use of ordinary tin-lead solder will dissolve the fused bond of silver that makes the solder adhere to the porcelain, especially if the soldering iron is quite hot.

## Trouble Shooting

Most troubles are caused by tube failure so this is the first thing to suspect in trouble shooting. If the trace cannot be centered vertically check to see if the unit is firmly plugged in. Be sure there has been adequate time for the tubes to warm up completely. Then, with the **TRACE RESTORER** button depressed, turn the **VERT. POS. RANGE** control through its range. If the trace cannot be centered, try changing V3805 and V3905.

If the trace can be centered with the **TRACE RESTORER** button depressed, but drifts off the screen upon its release, turn the **MILLI-VOLTS/CM** switch to 10. If this allows the trace to be centered try changing V3205 and V3265 or possibly V3015. If not, try changing V3805 or check the coupling capacitors. No simple formula can be given for finding all troubles, but the Circuit Description section of this manual may help.

## Adjustments

Allow the unit to warm up for at least five minutes before making any adjustments. All adjustments can be made with the preamp plugged into an oscilloscope that has its panels removed or if the Type EP53 Plug-in Extension is used.

## Positioning Adjustment

Center the **VERTICAL POSITION** control and, with the oscilloscope sweep running recurrently, adjust the **VERT. POS. RANGE** control to center the trace.

## Gain-Adjustment

Connect a 20-millivolt signal from the oscilloscope calibrator to the **INPUT** connector, pin 3. Ground pin 2. Set the **MILLIVOLTS/CM** control to 5 and turn the **VARIABLE** control clockwise to the **CALIBRATED** position. Adjust the front-panel **GAIN ADJUST** control to obtain four centimeters of deflection.



### "Variable" Balance Adjustment

With the oscilloscope sweep free running and no signal connected to the input, rotate the **VARIABLE** control, concentric with the **MILLIVOLTS/CM** knob, back and forth. If necessary, adjust the "**VARIABLE**" **BALANCE** control until there is no deflection of the trace as the **VARIABLE** control is rotated.

### Differential-Balance Adjustment

Three adjustments are made to provide maximum rejection of common-mode signals.

- a. Connect a 2-volt signal from the oscilloscope calibrator to pins 2 and 3 of the **INPUT** connector.

PIN 1 - GROUND  
PIN 2 - BLACK  
PIN 3 - RED

- b. Set the **MILLIVOLTS/CM** control to .05.
- c. Preset the **DIFF. BAL.** control to the center of its range.
- d. Adjust C3095 and C3155 just above the **HEATER BAL.** control for minimum amplitude of the spikes.
- e. Turn the **HEATER BAL.** control about one-eighth turn in either direction and wait until the drifting has stopped. If the balance is improved, continue moving the heater balance in the same direction. If the balance deteriorated move the heater balance in the opposite direction. Continue this process until optimum balance is achieved.
- f. Fine Balance is accomplished by varying the **DIFF. BAL.** control.



# MODIFICATION NOTICE

## CLIP-MOUNTED CERAMIC STRIPS

YOUR INSTRUMENT MAY BE EQUIPPED WITH CLIP-MOUNTED CERAMIC STRIPS. IF YOU FIND IT NECESSARY TO ORDER THESE STRIPS FOR REPLACEMENT, BE SURE TO CONSULT THIS SHEET. INCLUDE A DESCRIPTION OF THE PART, PART NUMBER, INSTRUMENT TYPE AND SERIAL NUMBER.

### CERAMIC STRIP PARTS LIST

	PART NUMBER
STUD, CLIP, MOLDED NYLON	355-046
SPACER, MOLDED NYLON, 5/32" HEIGHT	361-007
SPACER, MOLDED NYLON, 1/4" HEIGHT	361-008
SPACER, MOLDED NYLON, 3/8" HEIGHT	361-009
CERAMIC STRIP, 7/16" BY 3 NOTCHES	124-092
CERAMIC STRIP, 7/16" BY 5 NOTCHES	124-093
CERAMIC STRIP, 7/16" BY 7 NOTCHES	124-094
CERAMIC STRIP, 7/16" BY 9 NOTCHES	124-095
CERAMIC STRIP, 7/16" BY 11 NOTCHES	124-106
CERAMIC STRIP, 3/4" BY 1 NOTCH	124-100
CERAMIC STRIP, 3/4" BY 2 NOTCHES	124-086
CERAMIC STRIP, 3/4" BY 3 NOTCHES	124-087
CERAMIC STRIP, 3/4" BY 4 NOTCHES	124-088
CERAMIC STRIP, 3/4" BY 7 NOTCHES	124-089
CERAMIC STRIP, 3/4" BY 9 NOTCHES	124-090
CERAMIC STRIP, 3/4" BY 11 NOTCHES	124-091



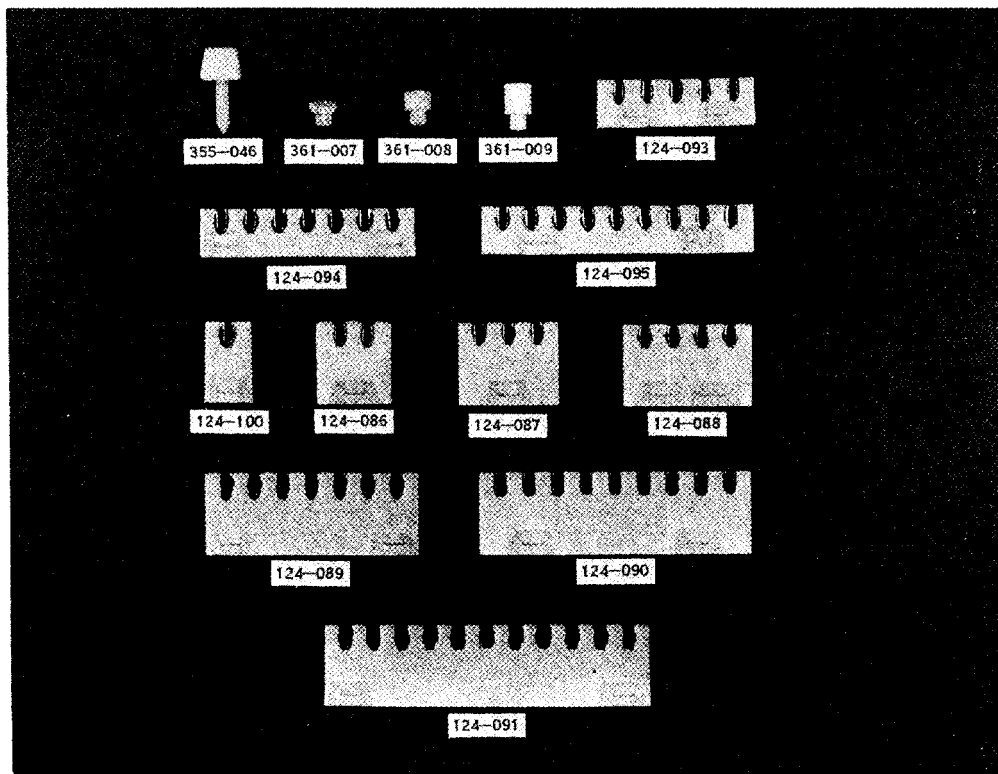

CERAMIC STRIPS AND MOUNTINGS USED IN  
TEKTRONIX EQUIPMENT.

### ABBREVIATIONS

Cer.	ceramic	m	milli or 10 <sup>-3</sup>
Comp.	composition	Ω	ohm
EMC	electrolytic, metal cased	Poly.	polystyrene
EMT	electrolytic, metal tubular	Prec.	precision
f	farad	PT.	paper tubular
h	henry	Tub.	tubular
k	kilohm or 10 <sup>3</sup> ohms	v	working volts dc
meg	megohm or 10 <sup>6</sup> ohms	Var.	variable
μ	micro or 10 <sup>-6</sup>	w	watt
μμ	micromicro or 10 <sup>-12</sup>	WW	wire wound
	GMV		guaranteed minimum value

### LOW-LEVEL DIFFERENTIAL PREAMP

						Order Parts by Number	
Capacitors							
C3095	1.5-7 μμf	Cer.	Var.	500 v		281005	
C3155	1.5-7 μμf	Cer.	Var.	500 v		281005	
C3165A,B	.5 μf	Special			± ¼%	295060	
C3605A	.5 μf	} Special — manufactured by Tektronix. Order replacements from factory.				291010	
C3605B	.1 μf						
C3605C	.01 μf						
C3605D	.001 μf						
C3705A	.5 μf	} Special — manufactured by Tektronix. Order replacements from factory.				291010	
C3705B	.1 μf						
C3705C	.01 μf						
C3705D	.001 μf						
C3805	200 μμf	Mica	Fixed	500 v	10%	283511	
C3815	.0022 μf	PT	Fixed	400 v	20%	285543	
C3825	.01 μf	PT	Fixed	400 v	-2%+20%	285510	
C3835	.047 μf	PT	Fixed	400 v	20%	285519	
C3845	22 μμf	Cer.	Fixed			281511	
C4005	.1 μf	PT	Fixed	400 v	20%	285526	
C4015	.1 μf	PT	Fixed	400 v	20%	285526	
Resistors							
R3015	10 meg	½ w	Fixed	Comp.	10%	302106	
R3025	200 Ω	2 w	Var.	Comp.	20%	311063	
R3035	300 k	½ w	Fixed	Prec.	1%	309125	
R3045	10 meg	½ w	Fixed	Comp.	10%	302106	
R3085	41.5 k	5 w	Fixed	Prec.	1%	310512	
R3095	22 meg	½ w	Fixed	Comp.	10%	302226	
R3155	41.5 k	5 w	Fixed	Prec.	1%	310512	
R3165	22 meg	½ w	Fixed	Comp.	10%	302226	
R3205	270 Ω	½ w	Fixed	Comp.	10%	302271	
R3215	56.5 k	½ w	Fixed	Prec.	1%	309040	
R3225	2 k	2 w	Var.	Comp.	20%	311008	
R3235	10 k	2 w	Var.	Comp.	20%	311016	
R3245	56.5 k	½ w	Fixed	Prec.	1%	309040	
R3265	500 Ω	2 w	Var.	Comp.	20%	311005	
R3295	27 k	½ w	Fixed	Comp.	10%	302273	
R3405	80 k	½ w	Fixed	Prec.	1%	309108	
R3415	26.67 k	½ w	Fixed	Prec.	1%	309107	
R3425	8.89 k	½ w	Fixed	Prec.	1%	309106	
R3435	4.21 k	½ w	Fixed	Prec.	1%	309105	
R3445	2.05 k	½ w	Fixed	Prec.	1%	309104	



## Resistors (Continued)

Order Parts  
by Number

R3455	808 $\Omega$	1/2 w	Fixed	Prec.	1%		309103
R3465	402 $\Omega$	1/2 w	Fixed	Prec.	1%		309102
R3505	41.5 k	5 w	Fixed	Prec.	1%		310512
R3515	41.5 k	5 w	Fixed	Prec.	1%		310512
R3605	5 meg	1/2 w	Fixed	Prec.	1%		309087
R3615	2 meg	1/2 w	Fixed	Prec.	1%		309023
R3705	5 meg	1/2 w	Fixed	Prec.	1%		309087
R3715	2 meg	1/2 w	Fixed	Prec.	1%		309023
R3755	22 meg	1/2 w	Fixed	Comp.	10%		302226
R3805	20 k	2 w	Var.	Comp.	20%	Vert. Pos.	311018
R3815	3.3 meg	1/2 w	Fixed	Comp.	10%		302335
R3825	56.5 k	1/2 w	Fixed	Prec.	1%		309040
R3835	56.5 k	1/2 w	Fixed	Prec.	1%		309040
R3845	20 k	2 w	Var.	Comp.	20%	Ver. Pos. Range	311018
R3855	1 meg	1/2 w	Fixed	Comp.	10%		302105
R3865	240 k	1/2 w	Fixed	Comp.	5%		301244
R3875	240 k	1/2 w	Fixed	Comp.	5%		301244
R3905	82 k	1/2 w	Fixed	Comp.	10%		302823
R3915	82 k	1/2 w	Fixed	Comp.	10%		302823
R4005	1.5 k	5 w	Fixed	WW	5%		308061
R4015	4.5 k	5 w	Fixed	WW	5%		308066
R4035	167 $\Omega$	5 w	Fixed	WW	5%		308045
R4055	330 $\Omega$	1/2 w	Fixed	Comp.	10%		302331
R4065	330 $\Omega$	1/2 w	Fixed	Comp.	10%		302331
R4075	1 k	1/2 w	Var.	Comp.	20%	Heater Bal.	311091

## Switches

SW3205	2 wafer	8 position	rotary	MV/CM	260123	262087
SW3305*	3 wafer	5 position	rotary	LF RESPONSE	260102	262088
SW3755	double pole	single throw	push button	TRACE RESTORER	260135	—
SW3805*	2 wafer	5 position	rotary	HF RESPONSE	260102	262088

## Vacuum Tubes

V3015	12AX7	Input Amplifier		154043
V3205	5879	Gain Control Stage	} Checked	157052
V3265	5879	Gain Control Stage		
V3805	12AU7	Positioning Amplifier		154041
V3905	12AU7	Output Cathode Follower		154041
V4005	OB2	Voltage Regulator		154075
V4015	OB2	Voltage Regulator		154075

\*SW3305 and SW3805 shafts are concentric. Furnished as a unit.



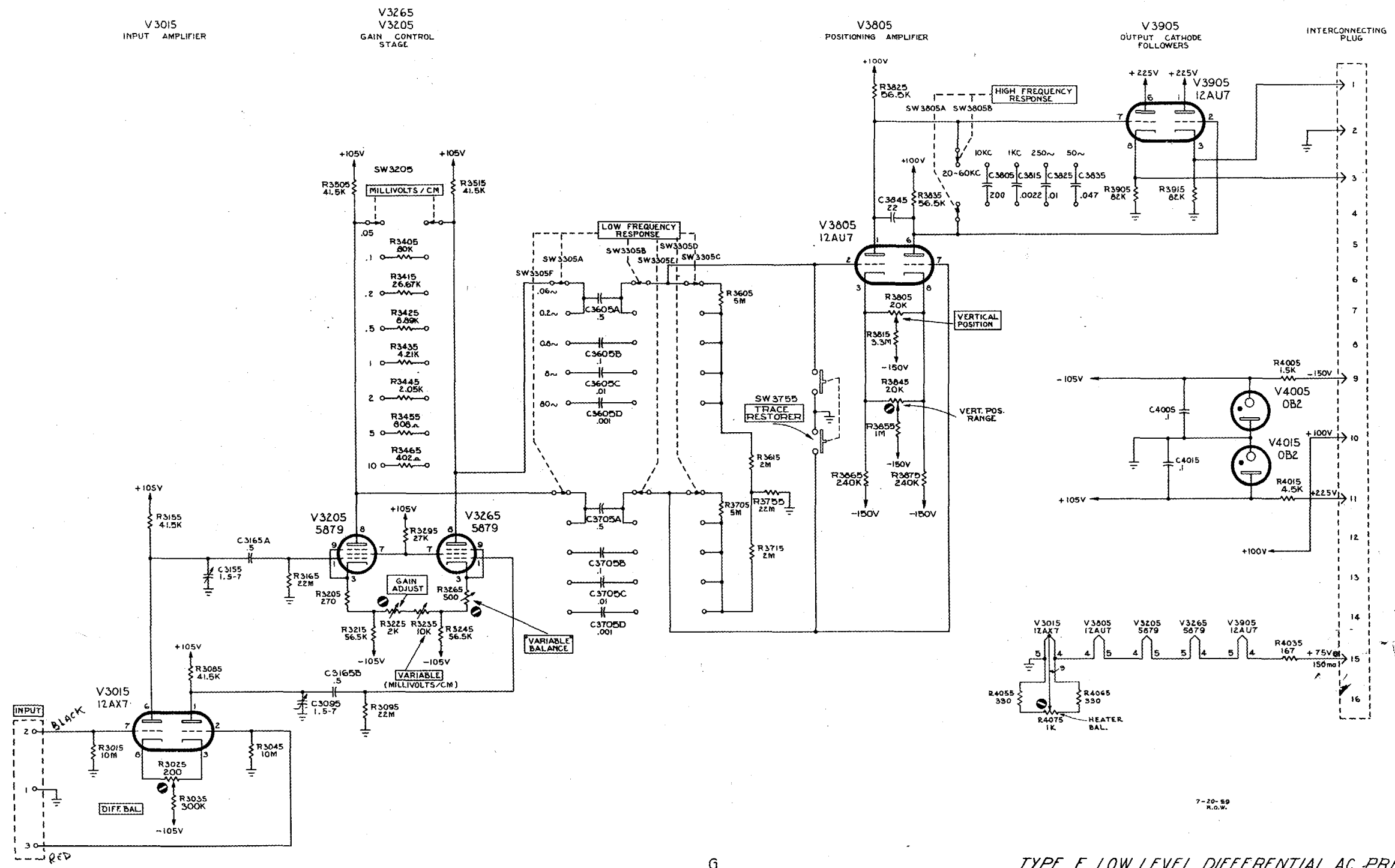

7-20-59  
R.G.W.

TYPE E LOW LEVEL DIFFERENTIAL AC PREAMP

### ABBREVIATIONS USED IN OUR PARTS LISTS

Cer.	ceramic	m	milli
Comp.	composition	$\Omega$	ohm
EMC	electrolytic, metal cased	Poly.	polystyrene
EMT	electrolytic, metal tubular	Prec.	precision
f	farad	PT	paper tubular
h	henry	Tub.	tubular
k	thousands of ohms	v	working volts dc
meg	megohms	Var.	variable
$\mu$	micro	w	watt
$\mu\mu$	micromicro	WW	wire wound
	GMV		guaranteed minimum value

### ABBREVIATIONS USED IN OUR CIRCUIT DIAGRAMS

Resistance values are in ohms. The symbol k stands for thousands. A resistor marked 2.7 k has a resistance of 2,700 ohms. The symbol M stands for million. For example, a resistor marked 5.6 M has a resistance of 5.6 megohms.

Unless otherwise specified on the circuit diagram, capacitance values marked with the number 1 and numbers greater than 1 are in  $\mu\mu\text{f}$ . For example, a capacitor marked 3.3 would have a capacitance of 3.3 micromicrofarads. Capacitance values marked with a number less than 1 are in  $\mu\text{f}$ . For example, a capacitor marked .47 would have a capacitance of .47 microfarads.

Inductance values marked in mh are in millihenrys. Inductance values marked in  $\mu\text{h}$  are in microhenrys.

Your instrument **WARRANTY** appears on the reverse side of this sheet.

SERIAL NO. 3421

### **IMPORTANT**

Include the INSTRUMENT TYPE and the above SERIAL NUMBER in any correspondence regarding this instrument. The above serial number must match the instrument serial number if parts are to be ordered from the manual. Your help in this will enable us to answer your questions or fill your order with the least delay possible.



### **WARRANTY**

All Tektronix instruments are fully guaranteed against defective materials and workmanship for one year. Should replacement parts be required, whether at no charge under warranty or at established net prices, notify us promptly, including sufficient details to identify the required parts. We will ship them pre-paid (via air if requested) as soon as possible, usually within 24 hours.

Tektronix transformers, manufactured in our own plant, carry an indefinite warranty.

All price revision and design modification privileges reserved.